

PLAY METER

OCTOBER 1, 1985

SYSTEMS NEW SEGMENT OF THE INDUSTRY



 001700 0000000 00/0
 WILLIAM A KURTZ
 3582 INGLESIDE RD
 SHAKER HTS OH 44122

TEHKAN

Gridiron Fight™

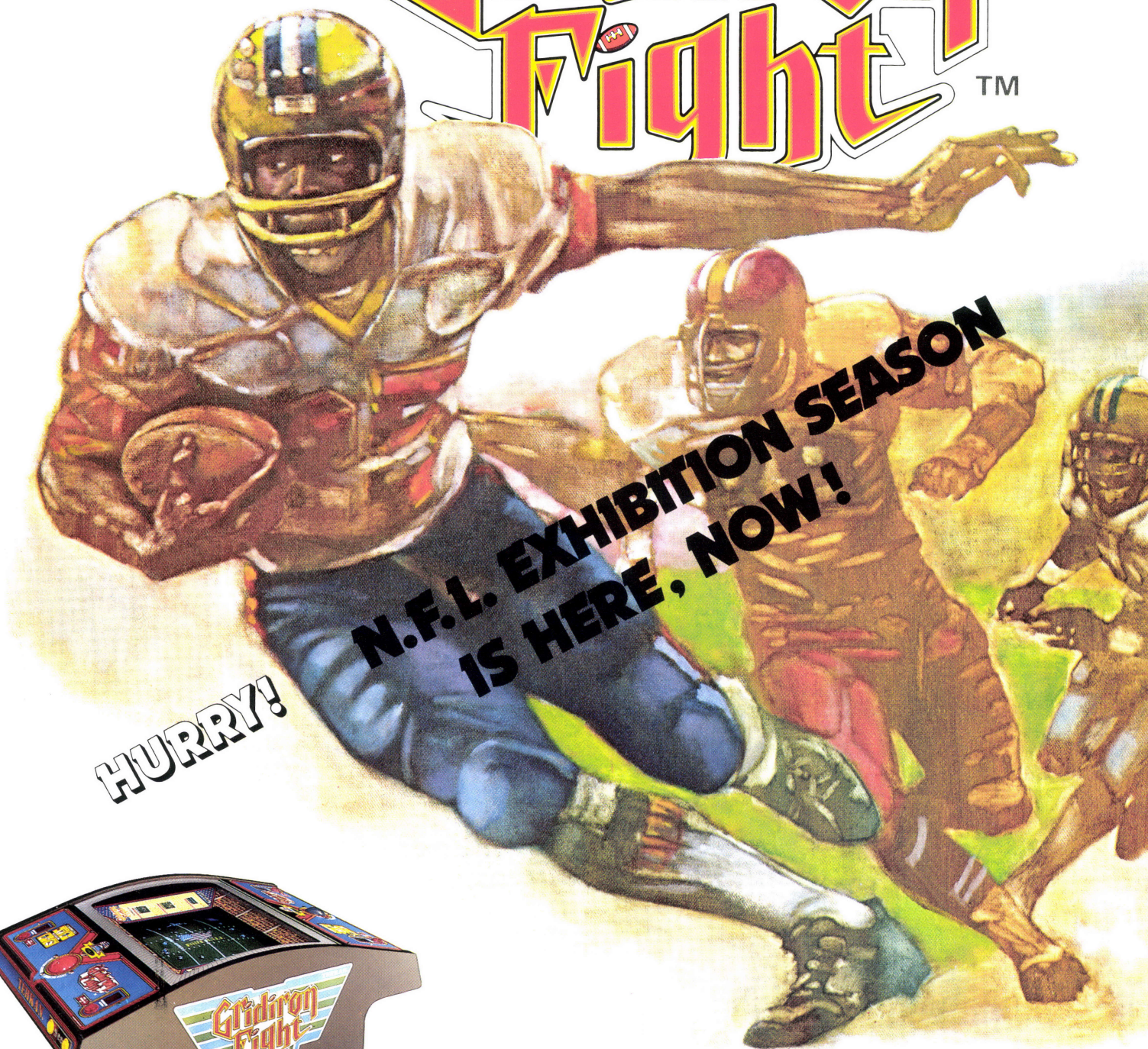

HURRY!

**N.F.L. EXHIBITION SEASON
IS HERE, NOW!**



Get Ready For A New Season Of Video Action.

Kick off the fall season with a spectacular new video game. Tehkan's GRIDIRON FIGHT is ready to give countless football fans the action they've been waiting for all summer long. With dramatic sound effects. Super-high-resolution graphics. And football strategy so realistic, it rewards either one or two players with a challenge that never ends. ★ Prepare for the return of football-season excitement. Contact your Tehkan distributor today.

TEHKAN, INC. 18010 S. Adria Maru Lane, Carson, CA 90746
Phone: (213) 329-5880, Fax: (213) 329-6134

PLAY METER

Twice a Month Publication for the Coin Operated Entertainment Industry

Member



CONTENTS/

Volume 11, Number 18/October 1, 1985

FEATURES

Coinman: **Bill Cravens** 16

Nintendo's Bill Cravens answers pertinent questions about systems and their impact on the coin-op industry.

Operators speak out on kits and systems 21

Some operators swear by system games; others feel kits are the only way to go. Here operators share their reasoning for each viewpoint.

Are Cigarette Machines Lucrative? 28

As operators explore alternative means of increasing revenues, cigarette vending heads many lists. Seasoned cigarette machine operators discuss the viability of cigarette vending.

Is Pinball Really Back? 30

We have heard rumors that pinball is making a comeback, and want to believe it is true. Roger Sharpe shares his insights into this question.

DEPARTMENTS

5 Up Front
6 Missing Children
7 Letters to the Editor
8 News
10 Equipment Poll
32 Frank's Cranks

36 Tax Tips
38 Gene's Gudgements
39 Technical Topics
42 New Products
45 Aids to the Trade
46 Classified

Cover: Designed by Margret Vincent.

CUSTOM DESIGNED
COINS-TOKENS
MEDALLIONS

.....
ALUMINUM - BRASS - BRONZE - SILVER - GOLD

VAN BROOK OF LEXINGTON, INC.

P.O. BOX 5044, LEX.KY. 40505

(606) 231-7100

KIDS LOVE OUR EGGS



**YOU WILL
TOO!**

Dispensing our popular and exciting toy-filled egg capsules is fun and profitable. Contact us for equipment and supplies.
 Toll-Free 1-800-EGG SHOP

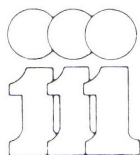

**INNOVATIVE
INDUSTRIES,
INCORPORATED**

2605 Grand Ave. • Carthage, MO 64836

**CALL US ON
OUR MONEY LINE**

**SUBSCRIBE
TO
PLAY METER**

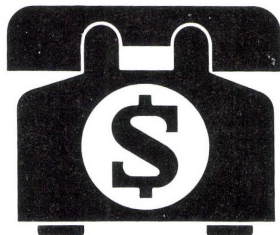

**ADVERTISE
IN
PLAY METER**

**LET'S ALL MAKE MONEY
504/488-7003**

STAFF

FOUNDER:

Ralph C. Lally II

PUBLISHER:

Carol P. Lally

VICE PRESIDENT:

John F. Lally III

VICE PRESIDENT:

J.A. VonderHaar

EDITORIAL DIRECTOR:

Valerie Cognevich

ART DIRECTOR:

Katey Schwark

TYPOGRAPHER:

Jo Ann Anthony

GRAPHICS DESIGNER:

Margret Vincent

TECHNICAL WRITER:

Frank Seninsky

CORRESPONDENTS:

Roger C. Sharpe

Charles C. Ross

Dick Welu

Richard Priesmeyer

Bill Kurtz

Irving L. Blackman

Harold I. Gould

Jeffrey Rosenthal

Gene Lewin

Linda C. Delery

COMPROLLER:

John F. Lally III

CIRCULATION MANAGER:

Renee' C. Pierson

ACCOUNTING:

Lenore R. Bramblett

DIRECTOR OF ADVERTISING:

J.A. VonderHaar

EUROPEAN REPRESENTATIVE:

Esmay Leslie

PLAY METER, October 1, 1985. Volume 11, No. 18. Copyright 1985 by Skybird Publishing Company. **Play Meter** (ISSN 0162-1343)(USPS 358-305) is published twice monthly on the 1st and 15th of the month. Publishing office: 6600 Fleur de Lis, New Orleans, La. 70124; **Mailing address:** P.O. Box 24170, New Orleans, LA 70184, U.S.A.; phone: 504/488-7003. For subscriptions: 504/488-7003. Subscription rates: U.S. and Canada—\$50; foreign: \$150, **air mail only**. Advertising rates are available on request. **No part of this magazine may be reproduced without expressed permission.** The editors are not responsible for unsolicited manuscripts. **Play Meter** buys **all rights**, unless otherwise specified, to accepted manuscripts, cartoons, art work, and photographs. Second-class postage paid at New Orleans, LA 70113 and additional mailing offices. **Postmaster:** Send Form 3579 to **PLAY METER**, P.O. Box 24170, New Orleans, LA 70184.

European Office: **PLAY METER** Promotions, "Harescombe" Warford Road, Northwood Middx. England, Northwood 29244.

Systems and a whole lot more

Systems have become the next generation of video games. No one could deny that Nintendo's VS System has given the industry a welcomed boost. Sente, though off to a shaky start, has taken pride in offering a multitude of system games to loyal customers. And Atari's two systems, and accompanying games, are worthy of the Atari name. Even Cinematronics, with its Cinemat System, is hoping to give operators what they need to survive. And no doubt more systems will make their debut at the upcoming AMOA show.

However, a caution flag should be raised. This industry has too long followed the hit syndrome. One factory takes a chance on something new and different, only to be the first of a string of companies producing the same product with few variations. We witnessed this peculiarity early in video game history. Space games begot space games which begot space games.

When Bally had the foresight to offer something diverse in its mega hit, *Pac-Man*, rumblings of disbelief sprang from industry circles as to the potential of a cartoon, maze game when the space oriented games such as *Asteroids* and *Space Invaders* topped the charts. However, players only knew that they liked this new cutesy game with the memorable fuzzy character.

Before long, the hit syndrome was in evidence as cartoon maze games dominated the market. Players liked them, too—that is for a while. Pretty soon, these games were not new and exciting, but almost every factory had their own cutesy game for the market.

We again witnessed the hit syndrome, at its most obvious, when rumors of laser games saving a dying industry were heard by everyone but the players. The scramble of factories to ready for AMOA '83 their own laser offering was the epitome of the hit syndrome. Not only did lasers not save the industry, but the industry survived in spite of this new technology.

So as we reminisce about the phenomenon of the hit syndrome, systems are making their presence felt in the marketplace. But we wonder what impact or effect systems will have on the coin-op industry. The impact so far has been positive. Operators sing the praises of these miracles offering a low cost way for them to offer players new games. And the games are good.

But there's a touch of *deja vu* here. Data East foresaw a market for systems several years ago and introduced its Deco System. Sega/Gremlin also recognized the potential and it too made inroads into systems. However, as sharp as these companies were on the concept, in actuality no exceptional games were ever made for the systems. Operators were left with the feeling that the factories promoted systems but introduced all the good games in dedicated form. And though these companies were fortuitous in their assessment of the kit market, their actions seemed to belie their predictions.

Since Data East led the way in the system concept and the reality of its predictions has materialized, some find it ironic that Data East has chosen to introduce only dedicated games. However, this factory may have perceived that if everyone else was following the hit syndrome into systems, someone would need to fill the void for dedicated games. After all, in the words of our coinman this issue, systems are not all there is. Data East has been extremely successful with its dedicated games. And in a diverse marketplace like this one, there must be a variety.

A medley of equipment must be the key. Questioning operators, and listening to their multitude of answers, is the best gauge to the reality of the industry. And though 20 operators may give 20 different opinions on what's right and what's wrong and why, one common thread is the need for games that will entertain players. Players don't care if they play a system, a conversion kit, a laser game, a dedicated game or some other innovation. But they demand fun and entertainment worth the quarter they are willing to pay.

And operators demand equipment that can meet the challenge from players. No one in this industry has a crystal ball to foretell the future, but all of us who have experienced the thrill of the video boom and the agony of the crunch, will never forget the past, or overlook the opportunity to learn from it.

Valerie Cognevich

Valerie Cognevich
Editorial Director

MISSING



April Rose Yates

D.O.B.: March 9, 1979
Hair: Blonde
Eyes: Blue
Height: 3'4"
Weight: 42 pounds

Disappeared August 18, 1984
from Cranford, New Jersey

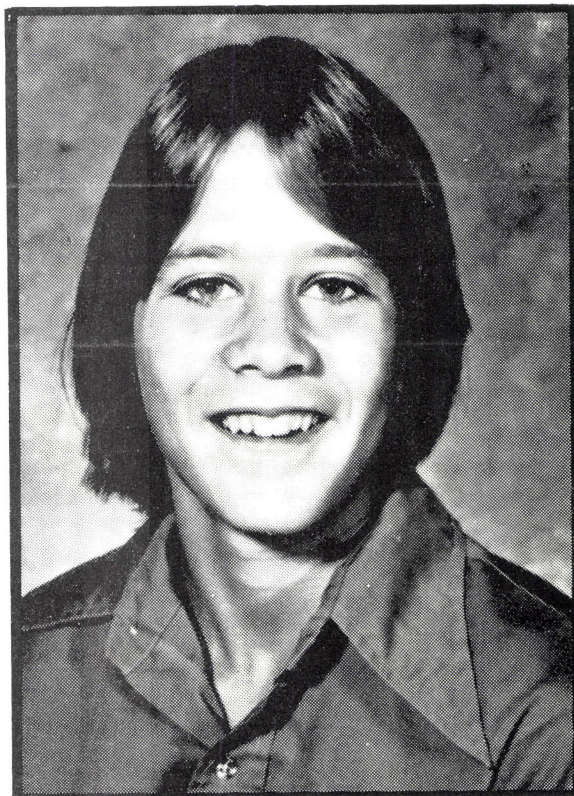

Gregory Eli Holman

D.O.B.: October 10, 1963
Hair: Reddish Brown
Eyes: Blue
Height: average
Weight: average

Disappeared October 9, 1978
from Scottsdale, Arizona

If you have information about either of these children please
call: 1-800-235-3535

HIDE AND SEEK FOUNDATION
V • O • C • A • L

Volunteers Can Call (503) 294-0746
Outside Oregon 1-800-547-9755 ext. 50

Distributed by:
Hide and Seek Foundation, Inc.
V • O • C • A • L
Video Operators Childrens Alert Line
P.O. Box 14574
Portland, OR 97214

Letters to the editor . . .

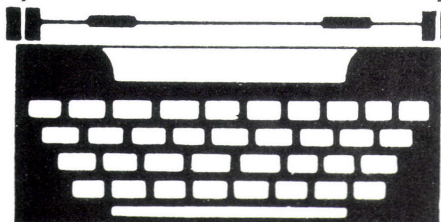

Great interview

Thank you so much for the recent interview. It's unbelievable the number of cards, letters, and telephone calls it's generated. I'm not just talking about from here in the U.S. either—how about the British West Indies?! I've conjured up a standard reply: "I've been here. I just must have been keeping my mouth shut too long!"

All kidding aside, I never expected operators and ex-operators to call and write. That really made me feel great.

Thank you and all the readers of *Play Meter* for the response.

Bernard Powers
Bally Sente
Sunnyvale, California

Applauds Atari

I take issue with Roger Sharpe's recent observation concerning the video games *Paperboy* and *Marble Madness*. In his Critic's Corner column (July 15), Mr. Sharpe suggests that the closed-end design technique discourages the masterful players by leaving them stranded for more action. He wrote, "Just to know it's possible to end a game is enough to turn off many players."

In my view, the reverse statement holds more truth—Just to know it's impossible to end a game is enough to turn off many players and potential newcomers to video games.

I applaud Atari and any other manufacturer that designs closed-end games. If this industry is to grow, we must begin to condition the player and non-players to expect a new and alternate format in coin-operate video game software.

Dennis DeNure
Madison, Wisconsin



Audio Visual Amusements

OFFERING THE FINEST
NEW AND USED EQUIPMENT
YOU'VE TRIED THE REST, NOW TRY THE BEST!!

We're Eager To Serve

1809 Olive Street, St. Louis, Missouri 63103

314/421-5100

for further information, call Pete Entringer collect

CAN•ALLEY



It's a winner! Shouldn't you have this tremendously popular money maker in your operation? Our coin operated Can•Alley is packing in players and profits everywhere.

As with all of our games you get advanced engineering, quality construction dependable operation and the support and service that make our games the best choice every time.

Let us help with your *merchandising needs*. We can help with tickets, prizes, redemption centers and merchandising methods. Call us today!

Bob's Space Racers, Inc.

427 15th Street, Daytona Beach, Florida 32017
Telephone: 904-677-0761

Manufacturers and designers of games since 1970.
Manufactured in the U.S.A.

NEWS

Operator convicted on video game copyright

Tom Goss of Coalton Amusement in Harlan, Kentucky, was convicted August 29, 1985, on criminal charges of dealing in counterfeit coin-operated amusement machines in violation of U.S. copyright law.

Goss, a 37-year old operator of video games, was arrested in April along with several others, including the recently convicted Tim O'Reilly of Montreal, as a result of an undercover FBI operation targeting importers, manufacturers, distributors, and operators of counterfeit video games.

Glenn Braswell, executive director of the American Amusement Machine Association in Alexandria, Virginia, said that the success of AAMA's efforts in aiding the FBI during their Atlanta undercover operation has established the association as an effective law enforcement tool for both current and future government investigations directed at other video game pirates.

"The conviction of an operator reaffirms AAMA's position to combat this criminal activity at all levels in the industry," said Braswell.

Goss is scheduled for sentencing in October and faces a maximum penalty of \$250,000 and/or two years in prison. •

Jukebox copyrights don't cover video jukeboxes

The U.S. Copyright Office has concluded that a video jukebox does not qualify as a "coin-operated phonorecord player," according to the national operators' association AMOA.

The September, 1985 issue of *The Location*, AMOA's membership newsletter, reported an operator learned of the non-qualification through a licensing examiner. The examiner refunded the operator \$150 in license fees "since the provisions of the law do not provide for the licensing of video jukeboxes." •

According to the report, the examiner urged the operator to contact the copyright proprietor identified on the videotape's copyright notice or to seek guidance from the performing rights societies.

"In order to properly license the public performance of the audio visual work," the U.S. Copyright Office reportedly said, "one would have to negotiate two licenses—one for the video portion and one for the audio."

The Copyright Office apparently made its decision based on a stipulation in the Copyright Act which said the jukebox license "must be used for no purpose other than the performance of non-dramatic musical works by means of phonorecords."

According to *The Location* report, that "would exclude coin-operated radio and television sets, as well as devices similar to jukeboxes that perform musical motion pictures." •



Fred Skor

Fred Skor acquires World Wide Distributors

Fred Skor, president and chief executive officer of World Wide Distributors, Inc., purchased all assets of

the Chicago firm September 1.

In concluding his takeover, Skor said he had full confidence in the future of the coin machine industry and predicted a significant growth for World Wide Distributors in the years ahead.

Skor said, "We are going forward with certainty that we are entering a new period of development and strength."

World Wide was founded 42 years ago exclusively as a distributor of games, phonographs, and vending machines. •

Williams reports upturn in game business

Williams Electronics has reported its first operating profit in two years.

In the company's third quarter earnings report for the period ending June 30, 1985, the Chicago-based game manufacturer said its third quarter earnings reflected an improvement in its amusement game revenues.

Louis J. Nicastro, chairman of the board and president of the company, said that, while the coin-op amusement game industry continues to be weak, amusement game operations for the company realized the modest operating profit before selling and administrative expenses.

Williams reported revenues of \$18,571,000 for the third quarter of fiscal 1985, up eight percent over third quarter revenues of \$17,142,000 for the corresponding period in the preceding year. •

Memetron licenses new game from Data East

Memetron, Elk Grove Village, Illinois, recently completed a deal with Data East for licensing *Shanghai Kid*. Said Memetron's Joe Kaminkow, "I saw this game in Japan and abso-

lutely flipped over it. I found out Data East had licensed it to make a dedicated game. However, their plans changed and Memetron was able to license it from Data East."

The game is a combination of wrestling, kick boxing, street fighting, and karate. The player begins in the streets of New York and ends up in Madison Square Garden.

According to Kaminkow, the game will be shown at the AMOA show in Chicago the end of October. •



Robert Mahoney

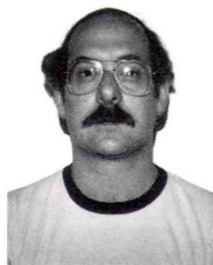

Mark Capitanio

New England distributor picks two Rowe employees

American Dispensing Systems (ADS) of Cranston, Rhode Island, recently appointed two former Rowe International employees to positions in its company.

Robert Mahoney was appointed to the position of sales and marketing director for the firm. Most recently, he was sales manager for Rowe Distributing in Dedham, Massachusetts.

Prior to that Mahoney was director of marketing for Bally Northeast of Norwood, Massachusetts.

Mark Capitanio was appointed to a part-time position overseeing all repairs, service, and conversions, including staff training. In addition to his duties with ADS, Capitanio is still employed at Magic Electronics where he is responsible for that company's kit games.

American Dispensing Systems provides kits and service support to operators in the six New England states. •

Nomac sponsors four-state tourney

Nomac, Ltd., manufacturers of *Pub Time Darts*, has announced the \$20,000 Four-State Soft Tip Championships for players in Minnesota, Wisconsin, Illinois, and Indiana. The tournament will take place November 1-3 in Chicago.

The state associations in each of the four states has tournament kits available for operators wanting to participate in the event. Qualifying kits can also be obtained by contacting Nomac at its toll-free number 1-800/323-0449.

The qualifying kit contains everything needed to run four weeks of qualifying tournaments and location championships.

The purchase price of the qualifying kits is \$50. For every kit purchased through one of the four participating state associations, Nomac will donate \$10 to the association.

There is no limit to the number of kits an operator may purchase.

In the November tournament, there will be three categories of competition—men's doubles, men's singles, and women's doubles.

The competition and prize money will be divided into three skill levels in the men's doubles competition and in two skill levels in the other two categories.

Additionally, the tournament will feature a mixed doubles category which will be open to all players. All players who participate in the four-state tournament will automatically qualify for *Pub Time's* \$50,000 national championships which are scheduled for the spring, said a Nomac spokesman. •

AAMA completes training film for U.S. Customs

Glenn Braswell, executive director of the American Amusement Machine Association (AAMA) in Alexandria, Virginia, announced the completion of a training film for U.S. Customs Service field agents on the identification of counterfeit coin-operated amusement machines.

Braswell said that this joint project was an outgrowth of the cooperative relationship between the association and Customs developed through ongoing AAMA Customs seminars on the differences between legitimate and counterfeit video games printed circuit boards (PCBs).

"The national distribution received by this film allows us to reach every U.S. port and will significantly aid the industry's fight against the growing tide of counterfeit video games from the Orient," said Braswell.

The 20-minute film featuring Braswell, U.S. Customs Service national advisory import specialist Thomas

KIDDIE RIDE OPERATORS



"Here's Solid State Sound"

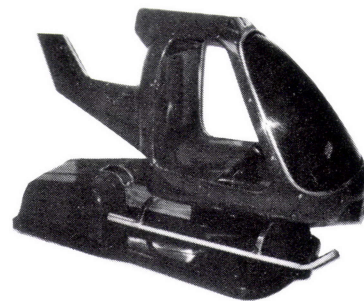

Solid State Lighting

...Add attract lighting to your units and increase profits...

KIDDIE RIDES

We carry a complete line of kiddie rides by:

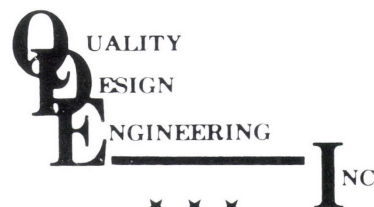

Call or Write:

P.O. Box 295 • Bus. 54 South Eldon, Missouri 65026

1-314/392-7964

1-314/392-3374

NATIONAL PLAY METER

Poll Information

The following are rankings of the top games in the coin-operated amusement industry. The games are ranked according to an index formulated from a regular survey of operators of coin-operated amusement equipment. Games not appearing on this poll either (1) did not generate a five percent response or (2) did not rank among the top 50 games in the country. The games are further identified by their general equipment classification type: Video, Pinball, and Novelty. The average index rating for all surveyed games for this individual survey was 78.

Top Ten Games of October 1 Issue

Game/Manufacturer	Index Rating	Game/Manufacturer	Index Rating
1. Demolition Derby/Bally Midway	183	6. Cheyenne/Exidy	133
2. Magmax/Nichibutsu	156	7. Hogan's Alley/Nintendo	129
3. Super Punch Out!!/Nintendo	151	7. 1942/Romstar	129
4. Commando/Data East	143	9. Kung Fu Master/Data East	119
5. Paperboy/Atari	138	10. Space Shuttle/Williams	116

Game/Manufacturer	Oct. 1	Sept. 15	Sept. 1	Aug. 15	Video	Pinball	Novelty
1. Demolition Derby/Bally Midway	183	183	—	233	•		
2. Magmax/Nichibutsu	156	—	133	—	•		
3. Super Punch Out!!/Nintendo	151	—	60	103	•		
4. Commando/Data East	143	206	155	197	•		
5. Paperboy/Atari	138	190	234	183	•		
6. Cheyenne/Exidy	133	99	130	109	•		
7. Hogan's Alley/Nintendo	129	135	117	143	•		
7. 1942/Romstar	129	203	114	93	•		
9. Kung Fu Master/Data East	119	134	125	140	•		
10. Space Shuttle/Williams	116	106	87	116		•	
11. Trivia Whiz/Merit	114	120	130	149	•		
12. Duck Hunt/Nintendo	108	122	140	133	•		
13. Spy Hunter/Bally Midway	105	114	136	116	•		
13. Hat Trick/Bally Sente	105	57	107	92	•		
15. The Games/Gottlieb	104	45	—	64		•	
16. Sorcerer/Williams	103	74	87	106		•	
17. Karate Champ/Data East	102	112	104	114	•		
18. Crossbow/Exidy	99	78	98	83	•		
19. Chicago Cubs Triple Play/Premier	98	112	92	67		•	
20. Galaga 3/Bally Midway	95	72	67	64	•		
20. Cobra Command/Data East	95	—	87	104	•		
20. VS. Baseball/Nintendo	95	112	73	67	•		
23. Bomb Jack/Tehkan	90	110	78	65	•		
24. Pole Position/Atari	89	90	75	85	•		

NOTICE: The sole purpose of this survey is to determine on a regular basis the top performing games in the country. Any attempt to use the results of this survey for any other purpose is unauthorized, wrongful, and misleading.

NATIONAL PLAY METER

Game/Manufacturer	Oct. 1	Sept. 15	Sept. 1	Aug. 15	Video	Pinball	Novelty
25. Pole Position II/Atari	88	113	84	95	•		
25. Yie Ar Kung Fu/Konami	88	114	125	117	•		
27. Star Rider/Williams	86	43	110	69	•		
28. Punch-Out!/Nintendo	83	95	85	96	•		
29. El Dorado/Premier	82	—	—	48		•	
30. Fireball/Bally Midway	80	60	—	68		•	
30. Spy Hunter/Bally Midway	80	94	60	77		•	
32. Special Forces/Magic	79	164	102	—	•		
33. Crown's Golf/Kitkorp	78	—	72	87	•		
33. VS. Excitebike/Nintendo	78	86	100	89	•		
35. Road Fighter/Konami	76	64	40	69	•		
35. Ice Fever/Premier	76	—	—	56		•	
37. Video Trivia/Greyhound	75	98	77	99	•		
38. Firepower II/Williams	74	56	67	74		•	
39. Two Tigers/Bally Midway	72	46	68	74	•		
39. Lode Runner/Digital Controls	72	—	—	82	•		
39. VS. Golf/Nintendo	72	64	—	83	•		
42. Ice Climber/Nintendo	71	—	—	87	•		
43. Birdie King III/Coin-It	70	67	—	—	•		
43. Eight Ball Deluxe/Bally Midway	70	83	53	67		•	
45. Marble Madness/Atari	69	52	74	97	•		
45. Great Swordsman/Romstar	69	—	—	92	•		
47. 10-Yard Fight '85/Memetron	68	82	—	—	•		
48. Trivial Pursuit/Bally Sente	65	—	73	—	•		
48. Samurai/Magic	65	114	96	90	•		
50. I. Robot/Atari	63	—	55	32	•		

AVERAGE WEEKLY GROSS

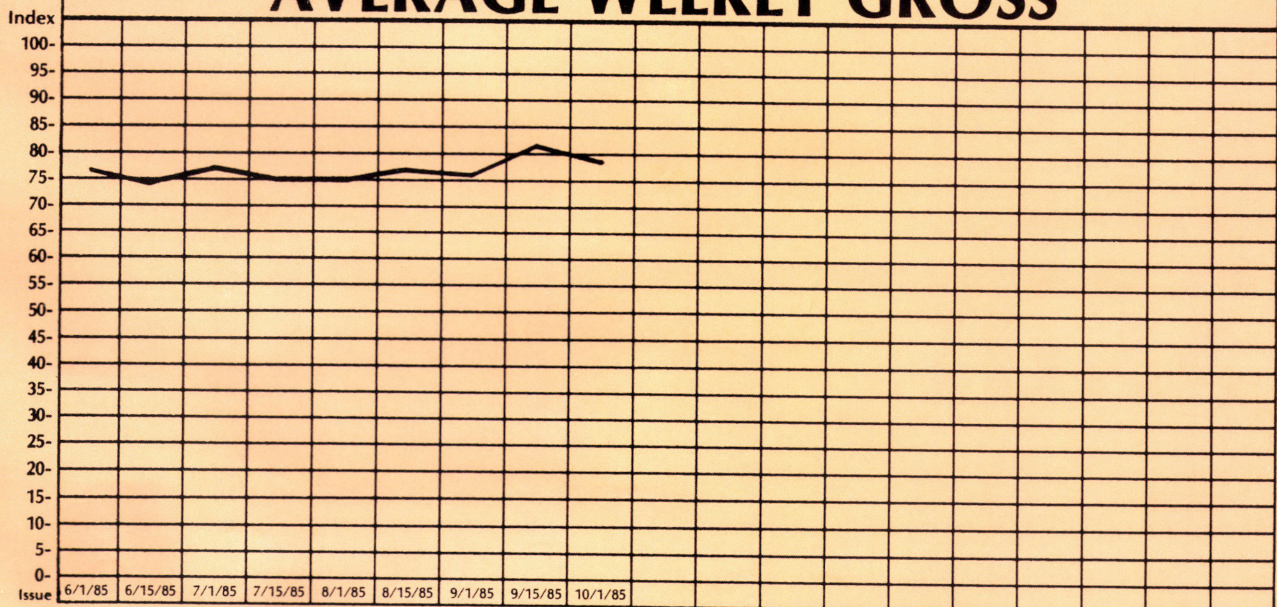

McKenna, and AAMA technical advisory committee chairman Ray Musci of Data East USA, Inc., covers all aspects of the identification process from shipping documents to the PCBs' electronic circuitry. •

Status Game appoints exclusive UK distributor

Status Game Corporation of Newington, Connecticut, has appointed P.C.M. Ltd., a subsidiary of Whitbread Inns, as exclusive distributor for its *Triv-Quiz* game in the United Kingdom. To obtain the distributorship, P.C.M. has placed initial orders for game units exceeding \$1 million.

"This is the largest single order in our company's history," said Irving Yaffa, Status president. "We are gratified to work with a company as highly regarded as Whitbread, and we look forward to a continuing, rewarding relationship," he added.

Whitbread Inns, one of the largest breweries in the United Kingdom, operates approximately 7,000 pubs. The game, which Status programmed with questions specifically for the British market, will be updated every eight weeks with new question kits, Yaffa said.

Triv-Quiz is now being made available to the home computer market, Yaffa added. •

Rock-Ola jukebox filmed for "American Treasury"

CBS News visited the U.S. Copyright Office Licensing Division August 14 to film the 1948 Rock-Ola jukebox currently on exhibit in the division for a segment of the new "American Treasury" series.

According to Nancy McGovern and Steve Kaufman, assistant producers, the spot containing the juke-

box footage is scheduled to air December 26, 1985, at 3:58 p.m.

The Model 1428 *Magic-Glo* phonograph filmed for the series was manufactured in 1948 by the Rock-Ola Manufacturing Corp. It was donated to the Library of Congress October 27, 1984, by David C. Rockola, founder and chairman of the board, on behalf of the Amusement and Music Operators Association and National Sound Industries of Mexico.

The "American Treasury" series consists of approximately 100 different one-minute informational broadcasts for young viewers for the CBS Television Network's 1985-86 season.

The televised segments focus on interesting and unusual facts about people, places, and events in real life and fiction with each segment based on materials and information found in the Library of Congress.

Popular personalities familiar to the young audience from the worlds of music, film, sports, television, and the theater will be the narrators of "American Treasury." To date, they include Olympic boxing champion Mark Breland, Olympic champion skater Scott Hamilton, actresses Stephanie Mills and Ann Reinking, and model Cheryl Tiegs. •

Sente to produce U.K. trivia version

Bally Sente of Sunnyvale, California, has negotiated with *Trivial Pursuit's* merchandisers to develop a British video game version of this newest edition based on the Genus I game.

Bally Sente is a software design, research and development subsidiary of Bally Manufacturing Corporation, Chicago.

"We alone are authorized to use the exact questions and answers from the board game," explained Bernard Powers, director of marketing and

sales for Bally Sente.

"The video game's successful earnings in the United States can be attributed to both the distinctness and familiarity of these questions."

No announcements were made to convert Genus II, Baby Boomers, Young Players, All-Star Sports, or Silver Screen to British board or video games.

In the arcade version of *Trivial Pursuit*, the player chooses one of four characters—Baron von Rightoiten, Cleofactra, Smartacus, and Billy Genius. The die rolls automatically, and the character moves that number of squares on a rectangular game grid. A question appears, and four successive answer choices follow.

After each question, the player must hit a button indicating whether the answer is right or wrong. Points are earned on the number of correct responses.

When a player answers one of the four corner questions correctly, there's a chance to earn a piece of the pie and bonus points. The monitor switches to a theater-like setting, and the playing character strolls across the center stage to face a challenging new question. Four choices again appear and correct responses earn higher point scores. If all four pieces of pie are earned before the time runs out, the player is awarded a bonus and listed on the high score table. •

AAMA opposes tax reform measures

The American Amusement Machine Association (AAMA) has contacted the chairmen of the Congressional tax-writing committees to voice the industry's opposition to several tax reform proposals now under consideration.

In a letter to Senate Finance Committee chairman Bob Packwood (R-Oregon) and House Ways and Means

Mali

The Henry W. T. Mali & Co., Inc.
257 Park Ave. South
New York, N.Y. 10010
Order Dept. 800-223-6468
N.Y. 212-475-4960
TWX 710-581-5522

Call Toll Free: (800) 223-6468

Billiard Cloth

#824—Plain, #924—Rubberbacked
Fast-Playing, Long-Wearing cloth for
coin-op tables.

Available through your distributor.

Write or call for color card.

Committee chairman Dan Rostenkowski (D-Illinois), AAMA executive director Glenn Braswell explained the elimination of the investment tax credit and depreciation allowance would "surely be the final death blow to the U.S. coin-operated machine industry."

Braswell stressed that even a stretch-out of the current equipment depreciation schedule would harm operators, given the average six-month life span of an amusement machine.

Additionally, Braswell stressed the industry's objection to a proposal which would levy an annual tax on all U.S. manufacturers to help fund an expanded toxic waste clean-up program.

"This proposal would further exacerbate our current economic situation given its obvious impact on product costs and the fact that little, if any, waste by-product is generated during the manufacturing of amusement machines," Braswell said.

AAMA has joined an alliance of U.S. corporations and industry associations organized to defeat the Superfund tax vote in Congress. ●



Jeff Walker

Walker joins Premier Technology

Jeff Walker has joined Premier Technology, Bensenville, Illinois, as national sales manager. Walker will be responsible for the sales and marketing in the United States and Canada.

Walker will be working closely with general manager, Gil Pollock, in

developing and introducing Premier's product line. Premier products have included *Ice Fever*, *Chicago Cubs Triple Play*, and *Bounty Hunter*. Pollock was with Mylstar when it was closed by parent company, Coca-Cola and went on to form Premier Technology out of certain Mylstar assets. Premier has focused on pinball during its year in business.

Walker was previously in sales with Nintendo of America. Said Pollock, "We are pleased to have such a qualified individual, like Jeff, become a member of our management team. Jeff's experience and knowledge in the marketplace will be an added benefit to Premier."

Lenore Sayers, national sales manager, will continue at Premier until October, at which time she will pursue personal interests. ●

PAMMA names new management firm

The Pennsylvania Amusement and Music Machine Association (PAMMA) has hired a new management firm, John Milliron Associates. John Milliron began the firm in 1979 and has acquired 25 clients since that time. Milliron, with a political background including being a member of the House of Representatives, will assume the title of executive director.

The new address and phone number are 229 State Street, Harrisburg, Pennsylvania 17101, telephone 717/232-5322. ●

Plans made for Air-Hockey Tourney

Air-Hockey's National Championships are scheduled for September 28-29, 1985, in Boulder, Colorado. Sponsored by Air-Table-Hockey, Wano-Coors, and other local businesses. The event is sanctioned by the U.S. Air-Table-Hockey Association. Cash and prizes totaling \$4,000 will determine the national champion. The best players from around the country will be competing for national rankings in the event, to be held at the University of Colorado Rec Center.

Top contenders include: Robert Hernandez of Houston, currently ranked Number One by the U.S. Air-Table-Hockey Association; Phil Arnold of Houston, Number Two U.S., four-time national runner-up; Bob Dubuisson of

THE CALENDAR

October 31-November 2

AMOA 1985 International Exposition of Games and Music, Hyatt Regency Chicago, Chicago, Illinois. Contact AMOA, 111 East Wacker Drive, Chicago, Illinois 60601. Telephone 312/644-6610.

To be announced (November)

Music & Amusement Association, Inc. (NY) Annual Meeting & Election of Officers. Contact Ronald Koppelman, 212/245-7550

November 22-24

Pinball Expo '85, Holiday Inn O'Hare, Chicago, Illinois. Contact Robert Berk, 216/369-1192

1986

February 7-9

Amusement Operators Expo (AOE '86), Mardi Gras weekend, Sheraton New Orleans Hotel, New Orleans, LA. Telephone 504/488-7003 for information.

March 4-5

International Gaming Business Exposition, Tropicana Hotel and Country Club, Las Vegas, Nevada, USA. Contact Conference Management Corporation, 17 Washington Street, P.O. Box 4990, Norwalk, Connecticut 06856. Telephone: 203/852-0500. Telex 284997.

March 7-9

Amusement Showcase International, Expocentre, Chicago. Contact Glasgow-Erikson Inc., 7237 Lake Street, River Forest, Illinois 60305. Telephone 312/771-3290.

International Shows

November 22-24

Incomat '85, Messepalast, Vienna. Organizers: Verband der Munzautomatenwirtschaft, 1200 Wien, Wallensteinstrabe 5, Austria. Phone 0222 332187.

November 25-26

The Scottish Preview, Stakis Normandy Hotel, Inchinnan Road, Renfrew, PA4 9AJ. Organized by Deith Leisure PLC, 127 Wandsworth High Street, Wandsworth, London SW18 4JB. Telephone 01-870 5238/5224. Telex 929222.

1986

January 13-16

ATEI, Olympia, London. Contact Amusement Trades Exhibitions, 122 Clapham Common North Side, London SW4 9SP. Telephone 01-228 4107.

SHANGHAI KID



In
New Jersey

ALPHA - OMEGA AMUSEMENT
6 SUTTON PLACE
EDISON, NJ 08817
201-287-4990 Frank the Crank
memetron
INC.

WELCOME!



AND MARDI GRAS

NEW ORLEANS
FEBRUARY 6, 7, 8, 9, 1986

SHANGHAI KID



In
Baltimore

STATES SALES & SERVICE
1825 GUILFORD AVE.
BALTIMORE, MD 21202
301-837-7177 Steve Koenigsberg
memetron
INC.

Boulder, Number Three U.S., winner of the March 1985 Houston Nationals and third-time national champion; Vince Schappel, Number Four U.S.; and Boulder's Mark Robbins, Number Five U.S., winner of the 1984 Boulder Nationals.

In addition to the pro division, players will be battling for honors in the Pro-Am, Expert, and Amateur divisions. Five-time National Women's Champion Barbara Marquis of Houston will be going for a record 6th straight title.

For more information, call 303/444-9164. •

Illinois Pay Phone Ops form association

Several pay phone operators and distributors in Illinois have formed the Independent Coin Pay Phone Association (ICPPA) to collectively fight issues detrimental to all private pay phone companies.

Founders of the association and their association titles include: Leonard Kraus, National Communications, president; Marty Segal, Republic Pay Phones, secretary; James Raim, Illinois Tel Inc., assistant secretary; Jeff Greenburg, Chicago Pay Phone Service, treasurer; and Craig Jacobs, Pay Tel Inc.

Said Republic's Segal, "Before the deregulation, the Bell companies would file a tariff with the Public Utilities Commission (in Illinois it's called the Illinois Commerce Commission) and it would be approved with no questions asked. With this association, we can intervene and will carry more weight than individual companies alone."

Segal, noting that it's time for other companies in the various states to form similar associations, said, "Each state should have some sort of association to confront problems with the Bell companies. If private pay phone companies are going to fight each other instead of banding together and fighting the Bell System, then pretty soon there won't be any fight left because Bell will completely shut

down the private pay phone industry."

Segal stressed that it's important to confront problems on a local level now. "If we can't win on a local level, there won't be anything to fight on a national level," he said. "If Illinois Bell does something we don't like, we have to sue them. They can easily raise the funds to fight us. But we have to be able to fund the litigation. The only way is pooling resources through an association."

The ICPPA is currently working on three petitions before the Illinois Commerce Commission. The first is to reopen the docket on directory assistant charges. Segal explained that the phone company does not charge customers for the service. However, one and a half cents is deducted from each quarter to cover the directory assistance charges. "The charge on directory assistance calls is 30 cents per call plus five cents tax, a total of 35 cents. It's up to us whether we charge the customer, but Bell does not charge, they just work it so everyone pays for those who use directory assistance," noted Segal.

The second issue is calls made with an AT&T charge card. On a Bell phone if an AT&T card is used, the owner of the location is paid six percent commission on those charges. However, if a private pay phone is installed, no one gets anything. "We feel that we should be getting something if a customer uses an AT&T credit card on our phones," said Segal.

And third, the association is pursuing a clear definition of public verses private locations. The Illinois Commerce Commission is very vague in its definitions, Segal noted. "The tariff says we can't place our phones in a ball park, for example, because it is a public location, but we can put one at the corner of a gas station because it is not a public location. So you see how confusing it is," lamented Segal.

Segal summed up, "This association is vital for the expanding pay phone market in Illinois. We need support of all concerned, especially manufacturers. The market won't be there for any of us if we don't pull together in our common goals." •

**WE ARE IN
THE ENTERTAINMENT
BUSINESS.**

Improper discounts can be costly

By Joseph Arkin, C.P.A.

Business firms annually absorb losses totalling millions of dollars by permitting customers to take improper discounts. This may not seem to affect your firm, but closely examining the facts reveals that improper discounts mount up to a sizeable sum and can adversely affect your profit and loss statement.

These unwarranted discounts are: (1) cash discounts taken after the invoice due date; (2) cash (or trade discount) taken on taxes included in invoice price; and (3) cash (or trade discount) taken on shipping, handling, and other special charges shown on invoice.

A common practice is to bill goods, allowing settlement at an optional date. Goods may be billed, for instance, 2/10 net 30. In essence, the customer is being told that there is a relationship between the time allowed for payment and the amount to be paid. For payments made within a 10-day period, a two percent reduction is offered. This reduction is generally called a cash discount, originating at the close of the Civil War when risk on open accounts was very great. And payments not made within the discount period must be net.

In today's money market there is valid reason to offer discounts. There is a direct relationship between the credit period and the loss from bad debts. Lengthening the credit period would undoubtedly result in increased losses from uncollectible accounts.

You can put cash generated from early collections to use by taking discounts on your own purchases, or reducing outstanding financial obligations for which you are paying increasingly higher interest rates.

A customer who takes a cash discount after the stated terms is cheating you out of the use of the money. You, in effect, are lending him money without recompense. Many municipi-

palities and states have sales and/or use sales. A customer is not entitled to deduct a cash or a trade discount on the part of the invoice price representing taxes. For instance, if you bill a customer \$100 for merchandise, and are required by local or state law to add, say four percent tax, your total invoice will read \$104. With terms of 2/10, net 30, your customer would only be entitled to \$2 discount if payment was made within 10 days, yet

*The first step in
stopping these losses
is making sure
invoices clearly
separate merchandise
sales price and
sales taxes.*

invariably the customer takes the discount on the full invoice, in this case \$2.08.

The vendor is responsible for collection of most (if not all) sales tax and must remit the amount actually billed, the amount required to be charged, or the amount actually collected, whichever figure is greatest. A firm with volume, retailer, manufacturer, or wholesaler, will sustain a substantial loss if discounts are allowed to be taken on sales taxes. (Note: Some sales tax laws apply only to sales made to the ultimate consumer and would exempt sales made for the purpose of resale.)

Invoices also may contain items for which the firm is not making a profit, but charging only its own costs, such

as freight and delivery. A customer who is billed for \$1,216.59 for merchandise and \$121.49 for freight (total \$1,338.08) is only entitled to a discount on \$1,216.59. Any discount taken on the freight charge of \$121.49 results in a loss to the vendor! If this bill was subject to terms of 3/10 net E.O.M., the improper discount alone would amount to \$3.64. If this seems trifling, check your freight, shipping, and handling charges for an entire year and compute your losses from customers taking discounts on these items, you might be surprised.

The first step in stopping these losses is making sure invoices clearly separate merchandise sales price and sales taxes.

The customer's monthly statement should show separate totals for merchandise and taxes, with the statement that a discount can be taken only on the merchandise portion, not on any charges for local or state taxes.

The same procedure should be followed for freight and shipping, etc. charges. The customer must be shown separate totals, both on the invoice and statement, so it doesn't become automatic to take the discount against the total amount owned.

When checks are received with improper discounts, only the independent firm can afford to return checks and demand issuance of a corrected check. Most firms would prefer to deposit the check and send a memorandum explaining the difference still due for unearned discount or discount erroneously taken on non-merchandise items.

It may not be easy to discard the ways of the past, although costly. Adherence to a fixed policy of demanding payment for improper discounts will help reduce your operating costs and consequently increase your profits. ●

COINMAN INTERVIEW



Bill Cravens

By Valerie Cognevich

Our Coinman this issue is Bill Cravens of Nintendo of America. Bill's experience in the coin-op industry covers operating, distributing, and manufacturing. He claims that the diversification of his experience has helped tremendously in understanding each viewpoint.

Twenty years ago, Bill started his career with Wurlitzer selling jukeboxes. From there he worked in the distributing end with Weymouth Distributing and then Portale (which is now Betson/Pacific).

Then veering from manufacturing and distributing, he worked for a large independent operator in Southern California, G & G Amusement, and eventually opened his own operation, Inland Empire Vending.

In the mid-seventies, Bill joined Meadows Games, advancing to the presidency. After leaving Meadows, Bill held the position of national sales manager for Cinematronics and Pacific Novelty, and then joined Universal U.S.A. "One reason I joined Universal is because I saw the potential of kits. I have always tried to stay close to operators and their needs, and I definitely saw a future in kits."

Bill was sales director when Universal surpassed all expectations on sales of its Mr. Do! series of kits. When the true system game came out, Bill once again saw the future potential. He soon left Universal and joined Nintendo of America where he has been the driving force behind the sales efforts and achieving a goal of 100,000 VS. Systems out by the end of the year. If you recall, 100,000 was about the number of Pac-Man games that penetrated the market.

How is a system different from a conversion kit?

Basically a system is a hardware mainframe. You can compare the games to the software you would change in a regular computer. A normal dedicated kit has one game and you put it into almost any game by replacing the board and everything else that's in it. The only thing you replace in a system is the software, the electronics stay the same.

So games are much easier to change in a system?

No question about it. As in the Sente system, there's only a cartridge to be plugged in and in ours, only several chips are replaced. It's simpler and much, much cheaper than converting the whole game.

When you get into a system, are you locking yourself into one manufacturer?

Yes, in a way you are but it's not such a negative factor. There are three things that operators feared about systems. The first two questions operators have

● *There still will be dedicated games they have to buy. The system is only a segment of our industry and not the entire thing.* ●

asked themselves are: How do I know the manufacturer will continue on with it? And, how do I know they won't raise the price once they get me locked in?

We have answered these objections by consistent prices we publish in the trade publications and in our brochures. We may have been a little slow in getting out some of the stuff we've talked about, but Nintendo is dedicated to having at least 15 games in its system with stable prices.

The third objection operators have voiced: Why should I lock myself into one company? It's a stupid question in the first place because when you buy a dedicated game you lock yourself into that company—obviously. You buy a kit and you also lock yourself into that company. When you buy a system, you lock yourself in too, but there's more potential with a system for improvement and upgrading games. Would an operator rather spend \$3,000 for a dedicated game and be locked in or a third of that and be locked into a system offering a variety of games that are easy to change.

Nintendo has been approached by several different companies who, because of the number of systems Nintendo has out, are in the process of developing games for Nintendo.

You're saying that other manufacturers see an advantage in developing games for your system instead of marketing their games themselves?

That's right. Let's do the numbers. Manufacturing is really just a numbers game. The top dedicated game is going to sell maybe 7,000 units in today's marketplace. The people who make the boards can make \$100 profit therein from Japan, and that's \$700,000. It may cost a couple hundred thousand to build it, so if they come out with a stone hit they might make half a million. A dedicated kit that is a "10" and I'm talking about on the level of *Commando* or *Yie Ar Kung Fu*, may sell only 8,000 to 9,000. We're talking about the same money for kits.

By comparison, say this company comes to us with the same hot game. We have 100,000 systems out there and we know that we can do 20 percent of the market, and they make \$75 a game from us. Now we're talking about a million and a half instead of the half million. The numbers make sense.

Of course, Nintendo is the most popular system out right now, the system is inexpensive and the conversions are cheap, but do you think systems in general will achieve anywhere near that success?

Yes, I think so. Sente has made some inroads. Atari has a couple of systems out now. Both of these

companies are seeing success. The selection Sente has for its system is numerous and Atari is adding to theirs.

However, I don't believe that operators can operate only system games. There still will be dedicated games they have to buy, and there will be kits they will have to buy. The system is only a segment of our industry and not the entire thing.

Do you think systems will ever be interchangeable allowing software from one system to be used in other systems' hardware or do you see a need for that?

I really don't see that happening although some would like to see it happen. But a system is not like a jukebox where you say, OK, everyone design 45 rpm records or let's all go to a video disk. What we are dealing with here is engineers. Our company's hardware engineers may decide that one system is good for doing ABC and maybe Sente's hardware people may say they don't want to do ABC, but want to do XYZ. So you have the creative people coming up with different ways to somewhat do the same thing. We are dealing with geniuses and it's pretty hard to believe we could get all the geniuses to think the same way. To be very honest, it would be bad if they did all think alike because it would stagnate growth and development.

Is that perhaps why Atari has the two systems, because each one is unique in certain features?

I think that's why. One has higher resolution. They are different systems.

Do you think Nintendo will come out with a System II?

We have *Punch Out!!* which is really a system. We have had two games for it already and are soon coming out with another. We promised two but are working on a third.

But Punch Out!! is not really a system as we perceive a system nor was it promoted as a system.

Punch Out!! was a very strong game. It wasn't promoted as a system although the subsequent games are just software changes.

But since Punch Out!! was such a strong game, operators didn't buy it based on what was to come but simply because it was a good game. However, with systems, doesn't an operator have to base his decision on future expectations?

Punch Out!! was strong on its own, but so are our
(continued on next page)

THE TICKET DISPENSER — WITH EXPERIENCE

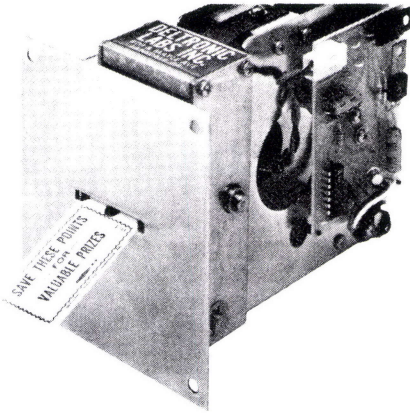

DELTRONIC LABS DL-1275 Ticket Dispenser is now available in kits—for quick and easy installation on existing video, pinball and novelty games.

For more than 7 years, top amusement manufacturers have relied on DELTRONIC LABS for quality ticket dispensers, backed by prompt and efficient service.

Now this time-tested dispenser is incorporated in kits for the same dependable performance on your present games.

You can renew player interest with tickets for awards and bonuses—and keep them playing again and again and again!

DELTRONIC LABS, INC.

Eight & Maple Avenue • Lansdale, PA 19446
215/362-9112 • Telex 317054



**WHY
IS THIS
GROWN
MAN
CRYING?**

HE MISSED IT . . .

**AOE '86
AND
MARDI GRAS!
NEW ORLEANS
FEB. 6, 7, 8, 9, 1986**

(continued from previous page)

gun games designed for the system. Operators could buy those solely on the strength of the game itself and never worry about changing it. *Marble Madness* and *Paperboy* are strong games also and operators probably bought those games on the strength of the one game.

But in buying a system shouldn't future games carry more weight?

It should have a lot to do with it. However, operators must also put on a long term hat. One thing that got a lot of people in this industry into a lot of trouble is we didn't look long term. We only looked at today and had no long term plan. An operator must say, this is where I want to be, and he must have some projections. It's rough in the operating business but if you don't have a plan and a goal, it is meaningless to see if you are making strides. Sometimes you get too caught up in the every day workings of the operation to see if your business plan is going forward.

And in that business plan operators have to decide what their purchases will be. And if an operator has a business plan he will probably decide to buy X number of systems and he must decide which company to buy from.

He must consider the reliability and strengths of the various companies offering systems. And he also has to look at distribution in the area. Maybe he works closely with someone who sells Sente product, so Sente may be the best choice for him.

So although future games are a consideration, other factors should be taken into consideration. Future games depend on the strength of the company.

Why should operators go through a distributor for something as simple as system software changes, and can distributors make money selling system software?

That's a hard question. Number one, if there were only going to be systems forever, if we thought systems were the ultimate, if we were never going to have anything else, and systems were utopia and camalot then maybe, just maybe, the operator would not need a distributor. But one thing our industry has proven over and over is that there is nothing more constant than change itself. I don't know what is going to make someone happy for a quarter tomorrow. And no one has a crystal ball, so no one knows what the players will want. It could be a monkey and an elephant taking dirty pictures of each other and that's what they want for a quarter. I just don't know.

But I do know there will be constant change in this industry. But you need distribution for other products. And you need distribution for a stablized marketplace. So that's why most manufacturers believe in going through distributors.

Systems were introduced previously but were not the overwhelming success that systems seem to be today. Why do you think operators were not receptive to Sega/Gremlin and Data East systems then?

When Dave Rosen (president of Sega) said in a speech that in only a few short years over 65 percent of the industry would be kits, snickers were heard through-

(continued on page 50)

OPERATORS SPEAK OUT ON KITS AND SYSTEMS

Still, operators are not trusting souls. The video game bust made them that way.

“There’s no glut, and that means when you put a game out people will play it.”

“I hope the manufacturers come out with new equipment like *Pole Position*.”

“Once you buy a system, you’re married to it, and I don’t want to be married to any one manufacturer.”

Five years ago Data East introduced the first convertible game system to the coin-operated amusement industry.

Today, Data East markets only dedicated games.

A few years ago Sega introduced its convertible game system; but, curiously, whenever the company came out with a good game, it wasn’t a systems game.

Operators have long memories. So the companies marketing systems games today—Bally Sente, Atari, Cinematronics, Konami, and Nintendo—all feel compelled to dissociate themselves from these earlier half-hearted attempts.

They make a point of telling you they are committed to introducing all their games as updates for their systems package.

And they tell you they have very strong future games; so operators aren’t stuck replacing one mediocre game with another.

And they insist they’re married to their systems, that they won’t abandon their systems six months from now in favor of some other approach.

Still, operators are not trusting souls. The video game bust made them that way.

Although more operators are hitching onto the systems approach than at any time before, a great number of operators are still resistant for a number of reasons.

Kits-only operators

James Blackburn of B&B Amusement Company in Richmond, Virginia, is one of the resisters. “I’m sticking exclusively with kits,” he told *Play Meter*.

He said, “Once you buy a system, you’re married to it, and I don’t want to be married to any one manufacturer.”

He said his experience with kit games has been outstanding, and he has no thoughts about changing that

strategy now. His company does a complete rebuilding job on all its conversion kits; and, as a result, he experiences no collection differences between a kit game and a dedicated game.

“I’m getting just as good collections on *Yie Ar Kung Fu* as I’m getting with *Kung Fu Master*, and my *Samurai* kit is doing as well as my *Karate Champ*,” Blackburn said.

He explained the reason for the good collections was because “there are so few games out there today. There’s no glut, and that means when you put a game out people will play it.”

Although a system justified itself with future conversion purchases, Blackburn insists he sees no reason for reconvertng a converted game. Only four or five times has he had to reconvert a kit game, and so he loses that advantage of buying an expensive systems game.

“Why should I spend \$2,500 to convert a game,” he said, “when I can spend \$800 and convert it with a kit.”

“With a kit, I can choose which games I want instead of being in a position where I can select from only one manufacturer’s games.

“The only advantage for me buying a system,” he continued, “would be if everything fit into it.”

He argued that a system game doesn’t really benefit the operator but, rather, would benefit a location owner who after purchasing one game, could constantly keep it updated.”

He also argued that a system game forces you to make the conversion on an already converted game, the result, he said, is “if you have only ten systems but 20 games, you have only ten games. With kits, I would have 20 games.”

Another systems game resister, Stan Streusand of Video Duels in Houston, Texas, also said he too did not want to be locked into a system.

“I’d rather pay \$800 to get a good quality kit than be forced to buy a \$400



In
New England

AMERICAN DISPENSING SYSTEMS
173 MACKLIN ST.
CRANSTON, RI 02920
401-946-2011 **Bob Mahoney**

memetron
INC.



In
Chicago

ATLAS DISTRIBUTING
2122 N. WESTERN AVE.
CHICAGO, IL 60647
312-276-5005 **Jerry & Eddy**

memetron
INC.



In
Cleveland

CLEVELAND COIN INT'L
17000 S. WATERLOO RD.
CLEVELAND, OH 44110
216-692-0960 **Ron Gold**

memetron
INC.



In
Bloomington

HANSON DISTRIBUTING CO.
9201 PENN AVE. SO., SUITE 1
BLOOMINGTON, MN 55431
612-884-6604 **Ray Hibarger**

memetron
INC.

systems game that fits the system but's not a good game." Even figuring that the cost of conversions with a kit game would raise the price another \$100-\$200, Streusand was still insistent upon buying kits above systems games.

"I'm still in favor of the kit game over the systems game because I'd rather be able to choose which games I want. I don't want to be in the position where I'm forced to buy what a manufacturer is going to sell me in the future. Once you've committed to buy from them," he said, "the manufacturer is not really committed to put forth his best effort.

"The advantage of kits," he continued, "is you can see what you're getting. As for a systems game manufacturer, he may come out with a few dynamite games, but what's behind that? What options do you have?" he asked.

However, he revealed he was "contemplating buying the Nintendo system because of its reputation and the fact that they're concerned" but insisted that would be his only exception.

Like Blackburn, he said he makes sure his conversion kit games are high quality and, as a result, doesn't realize any difference between kit games and dedicated games.

Pro-systems operators

And there are outspoken proponents of systems games who are equally opposed to kit games. One such systems game proponent is New Orleans Novelty's Louis Boasberg, who said, "I don't like kit games. In order to turn out a decent product, you have to take too much time and effort with a kit.

"I like systems games," he added. "There's less labor since the conversions are made for the game. We can take a game like *Stocker* and make it into *Gimme A Break* very easily. And most operators don't have the facilities or the shop to make those kit changes as easily."

Boasberg said, "If I had to name one thing that saved a lot of operators, it would be the Nintendo VS. System. Although I prefer dedicated games because of their newness and striking beauty and graphics, systems, especially Nintendo's, seem to work. By contrast, there have been few good kits released."

He stressed that manufacturers couldn't come out with a dedicated game and then release it as a kit because "that kills the resale value of

the dedicated game," he said.

Jim Stansfield, Jr. of Jim Stansfield Vending in LaCross, Wisconsin, also said he preferred systems games because "of the ease of converting them. And I find the income on them seems to be better than kits."

Stansfield added, "One of the nice advantages in bringing in a *Donkey Kong* and converting it," he said, "a man can easily do three or four in an afternoon. With conversion kits, only 1½ or two can be done in a day.

"So, you see, systems games make us more versatile as far as converting games, and they've helped our P&L."

But, Stansfield added, "I don't think systems games is a permanent fix. I hope the manufacturers come out with new equipment like *Pole Position*."

Some like both

Todd Erickson of Summit Amusements of St. Paul, Minnesota, said he was going in both directions, with reservations.

"I like Nintendo," he said. "I don't want to marry myself to one company, but I'm concerned with Atari's product. I'm concerned with the cabinet they've got to start out with."

Erickson echoed other operators' feelings about kits, that it allows the operator to pick whatever games he wants without having to restrict himself to one game maker.

"I'm very picky, and I've found no one company has creativity tied up. *Samurai* is good. *1942* is good. The trivia games are good.

"With systems games, your only advantage is the time of installation. It takes four to six hours to make a good conversion kit game and only 15-30 minutes for a systems game."

Still, he pointed out, "I'm buying some kits, some systems, and some dedicated games." He qualified that by saying that he bought only systems from manufacturers he had confidence with, and added, "You have to have confidence with whoever you do business with."

Then he focused in on Exidy's *Crossbow*, which he called a hybrid game form. "I'm very pleased with what they've done," he said. "People should realize the superior product Exidy has put out within the past two years. The only problem with the conversion factor on the Exidy game is that, as good as *Crossbow* is doing, I'm not about ready to change it to *Cheyenne* yet."

The example of Exidy, he said, was

an illustration of why the operator has to evaluate everything independently.

"The operator has to look at everything and see what's best for him," he said. "Poor conversions do no one any good. Poor conversions look like five-year-old games. But, by the same token, the man who takes a hard stand against systems games is wrong."

Erickson also said the industry needs more software system developers for existing systems.

Streusand echoed the same feeling. An operator who is resistant to systems games, he said, "I know it would be hypothetical and a mammoth task for everyone to get behind one system, but it would be a nice thing to see. I just don't think it would happen. If it did, though, I would be extremely receptive to that."

The company whose system is most targeted by this universal systems approach is Nintendo, which claims it will have around 100,000 systems out by the end of the year.

According to Bill Cravens, the company's marketing director, his firm has already been approached by a number of Japanese companies who are interested in supplying software for the VS. System.

When asked why the companies had to approach Nintendo and get its approval to making games that would play in the VS. System, Cravens said the system is patented and the games would employ that patent in their play.

To date, Cravens said, no company has agreed to making authorized software for Nintendo's software system.

But Cravens explained the rationale behind manufacturing a systems concept.

Said he, "Right now, if you have a blockbuster game, you can sell maybe 7,000. If it's a kit, maybe 10,000. By the end of the year, we should have around 100,000 systems out there, 20,000 of which will be gun games. You draw your own conclusions."

The Nintendo marketing executive also debated the most-raised argument against systems games. "No matter what you buy, whether, it's a system game or a kit game or a dedicated game, you're locked into that manufacturer."

Still, there exists significant operator resistance to systems games, though it is beginning to thaw. In most cases, the thaw seems to be affecting only Nintendo, although the other systems companies have certainly

been making inroads.

The operator resistance is based on several factors. Will the manufacturer produce good games for the system? Will the manufacturer raise the prices of the games once operators are locked in? And why should operators lock into one company?

But an unspoken yet very real question is festering right below the surface of those, and it deals with the immediate past history of convertible games; and the operators, once burned, are more hesitant than before.

Still, most industry people seem to insist that the choice is not really between kit games or systems games. Rather, it is that both have a place in the business today, along with dedicated videos, and pinballs, and pool tables, and electronic dart games, and jukeboxes, and so on.

Slowly, the industry is beginning to disentangle itself from its years of mistrust and reawaken to the fact that the coin-operated amusement industry is not exclusionary but inclusionary.

There's room for many different equipment types.

There's room for many different minds. •

KINKY KIT AND GAME CO.

NEW

ANNOUNCEMENT

NEW

SPECIALIZED TRIVIA

**I Love Lucy Trivia • Sexual Trivia • Gay Trivia
Florida Trivia • California Trivia
Texas Trivia • James Bond Trivia**

COMING SOON

Black Trivia • Hispanic Trivia

CALL (NOW) CALL

Kinky Kit and Game Co.

2854 A Stirling Road • Hollywood, Florida 33020

800/228-0925 • 305/923-5816

Game boards produced by Grayhound Electronics U.S.A.

Tax reform and its consequences

By Robert Feinschreiber

Once again, the federal government is turning its attention to the tax law. Tax proposals now before Congress can have significant implications for amusement machine manufacturers. These tax changes are described as tax reform by their supporters but not by their detractors.

The President has made tax reform a national priority, and it is a priority that most of us share. Yet tax reform has been a goal for more than two decades, and we are left to wonder why it never seems to be achieved.

You hear a great deal about tax reform, but this term is never defined satisfactorily. Any major change in the tax law that can affect a significant number of people is called tax reform.

Minor changes in the tax law that correct the specific provisions in a prior tax reform measure are called technical corrections acts. This year, we may see a number of technical corrections to last year's tax reform.

The impetus for tax reform begins to lose its consensus when we look at the specifics.

In fact, tax reform embodies not one goal, but three—providing equity, initiating incentives, and reestablishing simplicity.

Our fundamental dilemma is that these three goals are often in conflict, and have different priorities for amusement machine manufacturers.

Three goals

A tax measure that provides equity may not be an incentive and may not lead us toward simplicity. Most of us believe that we should not be pushed into higher tax brackets solely because of inflation. Consequently, the indexing of tax brackets to reflect inflation is viewed as equitable. However, this measure certainly isn't simple.

A measure that provides an incentive may not necessarily be equitable or simple. Tax incentives for

technological development, new construction, or exporting are important facets of our economy. However, these provisions are not fully equitable because they are not equally available to everyone. Also, as you would expect, these measures are far from simple.

We can readily simplify the tax law if we are willing to cast aside the considerations of equity and the need for economic incentives. For instance, it would be far more simple to tax social security payments fully rather than taxing them partially as at present. The elimination of tax deductions for pensions plan contributions would also increase simplicity at the expense of these other goals.

If simplicity alone is what we seek, we can eliminate personal exemptions, the deduction for charitable contributions, and the deductions for medical expenses and casualties. We could even go to the extreme of imposing the same tax on each person. Yet few of us would go this far, because simplicity is not our only goal.

Life is complex, and the tax law must be complex to realistically reflect the society in which we live and work. For this reason, there are practical limits to tax simplification. Congress must now wrestle with these limits.

Prior tax changes

We have already witnessed three major tax changes since Reagan became President.

In 1981, the goal was economic recovery through the reinstatement of tax incentives, and this goal was reflected in the title of the law, "Economic Recovery Tax Act."

By 1982, the goal became tax equity, and the law was titled "Tax Equity and Fiscal Responsibility Act." Perhaps exhausted from these efforts, Congress passed no major tax legislation in 1983. In 1984, Congress used tax reform as a means of raising revenue.

Now, in 1985, tax reform empha-

sizes simplicity. The proposed changes may not be equitable and may remove incentives, but these changes are likely to simplify the tax law. As a result, equity and incentives may then be the goals in next year's tax reform. Thus, tax reform remains an elusive and perhaps illusory goal.

Simplicity and complexity

Although the Administration claims to favor tax simplification, many of its proposals would increase the law's complexity. Two such provisions are the reforms that are planned for tax depreciation and business travel.

One Administration proposal that would specifically affect amusement machine manufacturers is the plan to modify tax depreciation and the investment credit. If this proposal is enacted, the time period between capital expenditure and recovery of these expenditures through the tax system would be increased. As a result, business would have less of an incentive to invest in new facilities.

The Administration has also proposed a measure that would limit travel and business meal deductions for amusement machine manufacturers and other businesses.

Under this proposal, daily allowances would be limited to twice the amount allowed to employees of the federal government. Since this rate varies city by city, the proposed rules would be far more complex than the present rules.

New tax laws do not affect everyone in the same manner. Some people are hurt while others benefit from the tax changes. In general, the benefits are claimed by those who make their case most effectively, not by those with the best case.

The 1985 tax changes may have an adverse impact on amusement machine manufacturers unless they are successful in making their case in Congress. ●

The Earnings of PacMan™ The Power of Defender™

NAMCO INC. © 1985 Magic Elec. Inc.

THE BIG
KIT HIT!

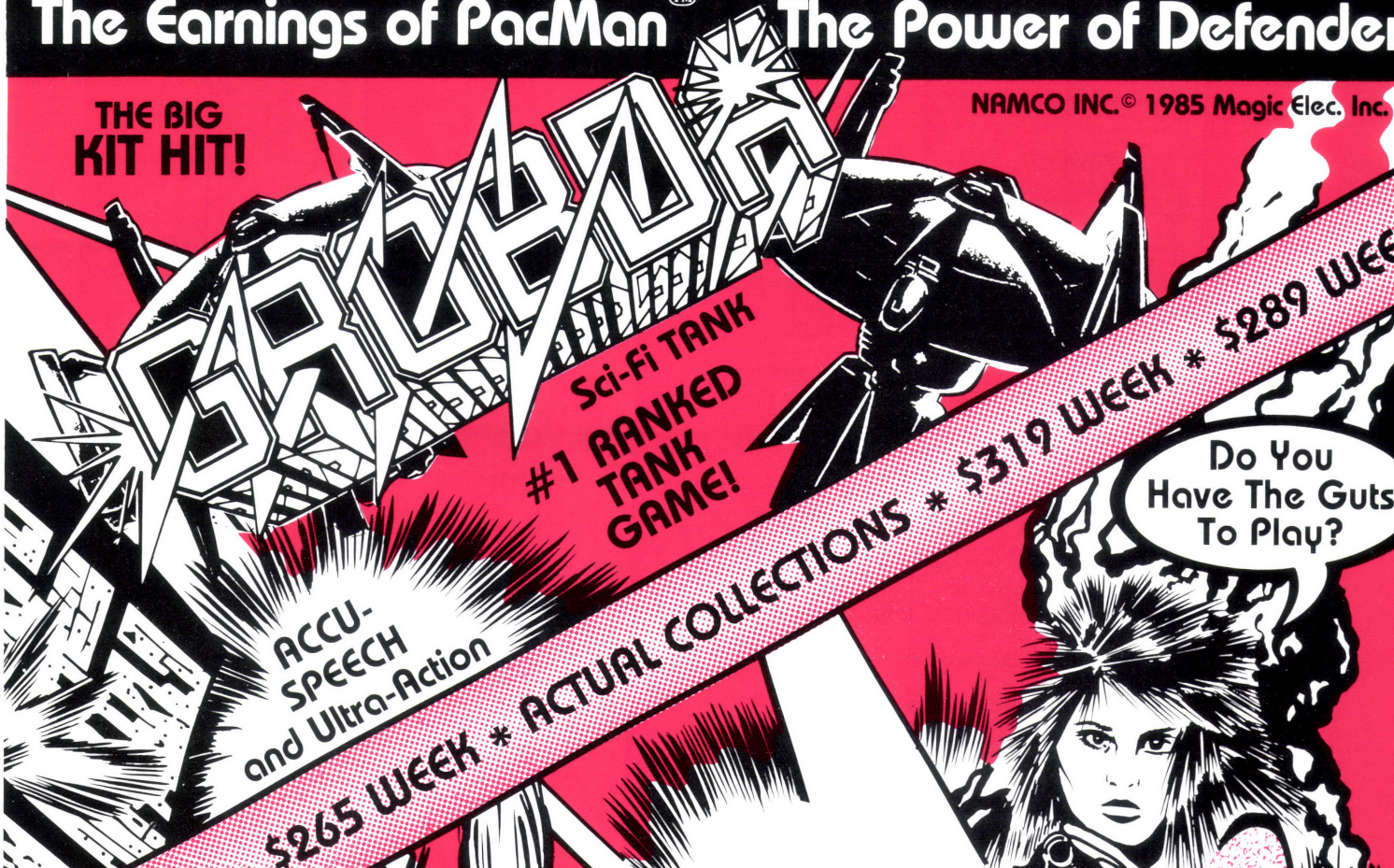

Sci-fi TANK
#1 RANKED
TANK
GAME!

ACCU-
SPEECH
and Ultra-Action

\$212 WEEK * \$265 WEEK * ACTUAL COLLECTIONS * \$319 WEEK * \$289 WEEK

Do You
Have The Guts
To Play?

namco
LONG
TERM
EARNINGS

Plexiglass
Marque
and CRT

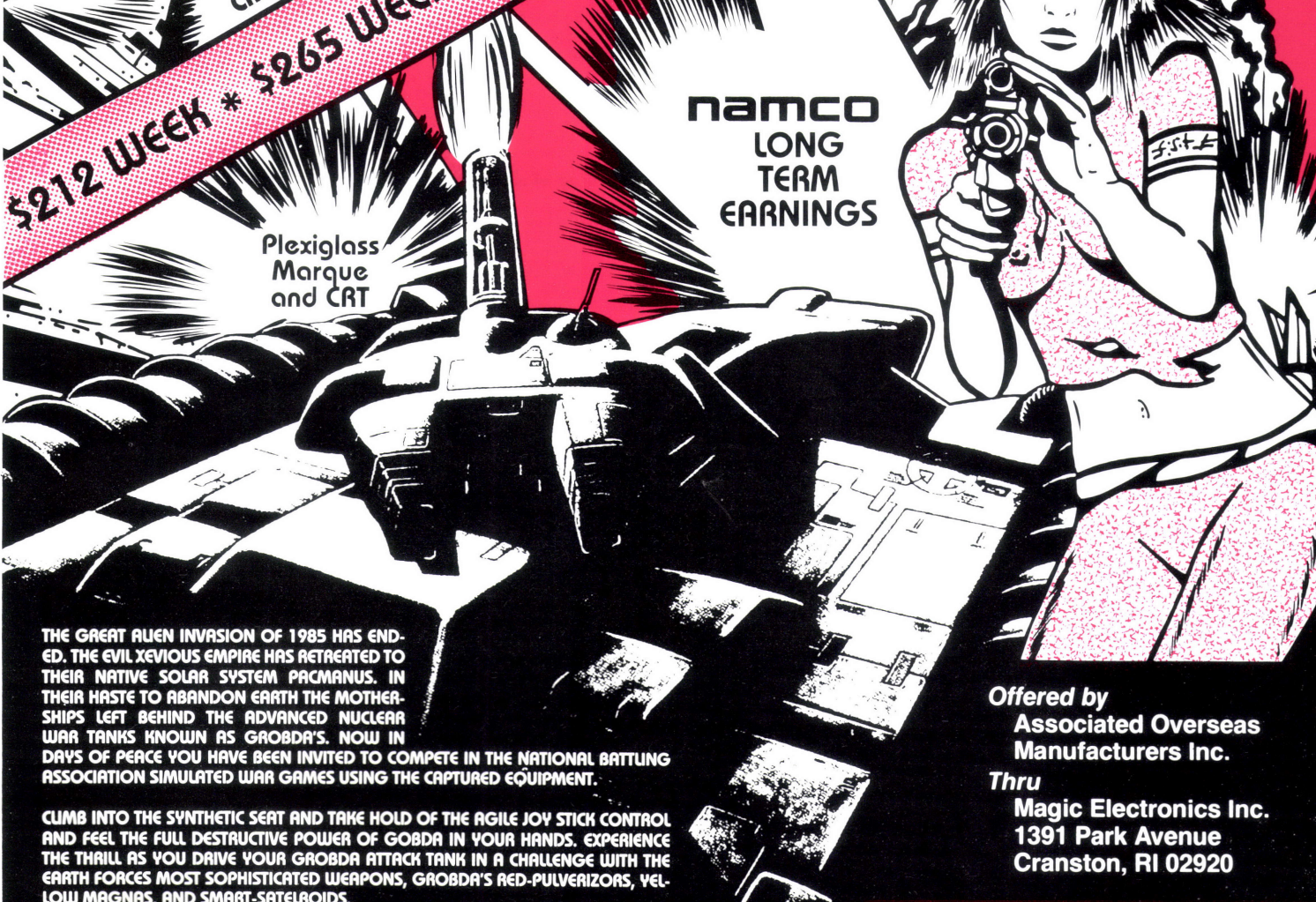

THE GREAT ALIEN INVASION OF 1985 HAS ENDED. THE EVIL XEVIOUS EMPIRE HAS RETREATED TO THEIR NATIVE SOLAR SYSTEM PACMANUS. IN THEIR HASTE TO ABANDON EARTH THE MOTHERSHIPS LEFT BEHIND THE ADVANCED NUCLEAR WAR TANKS KNOWN AS GROBDA'S. NOW IN DAYS OF PEACE YOU HAVE BEEN INVITED TO COMPETE IN THE NATIONAL BATTUNG ASSOCIATION SIMULATED WAR GAMES USING THE CAPTURED EQUIPMENT.

CLIMB INTO THE SYNTHETIC SEAT AND TAKE HOLD OF THE AGILE JOY STICK CONTROL AND FEEL THE FULL DESTRUCTIVE POWER OF GROBDA IN YOUR HANDS. EXPERIENCE THE THRILL AS YOU DRIVE YOUR GROBDA ATTACK TANK IN A CHALLENGE WITH THE EARTH FORCES MOST SOPHISTICATED WEAPONS, GROBDA'S RED-PULVERIZORS, VELLOW MAGNAs, AND SMART-SATELAIDS.

IF YOU EVER THOUGHT WAR WAS HELL . . . YOU NEVER PLAYED GROBDA!

Offered by
Associated Overseas
Manufacturers Inc.
Thru
Magic Electronics Inc.
1391 Park Avenue
Cranston, RI 02920

PacMan™ is a trademark of Bally/Midway, Defender™ of Williams Electronics, TANK™, Pole Position™, MISSILE COMMAND™ of ATARI.

The Strategy of TANK™ • The Speed of Pole Position™ • The Explosion of Missile Command™

IN THE UNITED STATES DISTRICT COURT
FOR THE WESTERN DISTRICT OF WISCONSIN

ARACHNID, INC.,

Plaintiff,

ORDER
85-C-338-C

v.

INDUSTRIAL DESIGN ELECTRONIC
ASSOCIATES, INC., DONALD P.
DeVALE, and BONITA DeVALE,

Defendants.

Upon plaintiff's motion for an injunction, due notice having been given, and after hearing arguments of counsel for all parties, IT IS HEREBY ORDERED

1. On August 23, 1985, the jury in this case returned a special verdict in plaintiff's favor on the issues of patent validity, patent infringement, and wilful infringement. I adopt that special verdict and enter judgment in favor of plaintiff accordingly. I find that defendants have failed to show that plaintiff's United States Letters Patent No. 4,057,241 for "Dart Game With Apertured Target Plates Resiliently Mounted" is not valid, and I find that the dart board structures of all of defendants' dart games infringe and continue to infringe plaintiff's patent and that defendants infringed plaintiff's patent wilfully.

2. Based upon a full and final trial on the merits and the jury's special verdict, I find that the dart board structures of defendants' dart games have infringed and continue to infringe plaintiff's patent and that apparently defendants remain ready, willing and able to sell dart games with the infringing dart board structure.

Accordingly, IT IS ORDERED that defendants Industrial Design Engineering Associates, Ltd., Donald P. DeVale, and Bonita J. DeVale are hereby permanently enjoined from directly or indirectly making, using, selling, or distributing in any way any of defendants' dart games under any name which comprise, use, employ or incorporate, in whole or in part, any of the infringing dart board components. This order of injunction shall apply to and be binding upon all defendants and any successors or assigns of defendants as well as defendants' officers, agents, servants, employees, and attorneys and upon those persons in active concert or participation with them who receive actual notice of this order by personal service or otherwise.

Entered this 30th day of August, 1985.

BY THE COURT:

Barbara B. Crabb

BARBARA B. CRABB
District Judge

NOTICE

On August 23, 1985, a Federal Court Jury in Chicago, Illinois returned a verdict in favor of Arachnid, Inc. and against Industrial Design Electronic Associates and its principal officers, Donald P. DeVale and Bonita DeVale. That jury found that the dart board on IDEA's electronic dart games infringed Arachnid's United States patent. The jury also found that IDEA and the DeVales had wilfully infringed Arachnid's patent.

Based on the jury verdict, the Court Order of permanent injunction against IDEA and its officers (re-printed on opposite page) was signed by United States District Court Judge Barbara Crabb on August 30, 1985. The Order permanently enjoins IDEA from making, using, selling, or distributing in any way any of defendant's dart games under any name which comprise, use, employ or incorporate, in whole or in part, any of the infringing dart board components. The Order of Injunction also enjoins not only IDEA and its employees from making, using, selling or distributing their dart games, but also further enjoins "those persons in active concert or participation with them who receive actual notice of the Order by personal service or otherwise".

Arachnid believes that those who use, sell or distribute IDEA's electronic dart games which contain the infringing dart board segments and spider are violating the Injunction Order. Arachnid hereby gives public notice that it will use all sanctions available to it under the law for any such violation of the Injunction Order.

Are cigarette machines lucrative?

By Linda C. Delery

Increased cigarette prices plus a general decrease in smokers have had a negative impact on the tobacco industry nationwide. In a recent survey, *Play Meter* asked cigarette machine operators if, in view of this, they found cigarette vending lucrative. In general the response was that, while not very profitable and while incapable of holding their own as a sole venture, cigarette machines still fill a void for a well-rounded vending operation.

Question: **Are cigarette machines lucrative?**

Bill Craft
President
Diamond Amusement Corporation
Central Oregon

Most definitely. Each location is treated differently. If they sell a certain number of cigarettes per week, we give a commission. If they sell less than two cartons per week, no commission. The commission on two to five cartons is five cents per pack; on five to ten cartons, ten cents per pack; and over ten cartons, 15 cents per pack. The locations that don't sell, we eliminate.

There's nothing we can do, other than giving the location a nice clean cigarette machine with wood grain finish. In the cigarette business, location is the key. You want a high traffic area such as the front door, back door or bar.

Bars and restaurants do better than malls. Put them in a saw mill where 300 to 400 people work and you do well. By keeping machines clean and not handwriting selection labels helps. If I see my brand handwritten, I wonder how long my brand has been in the machine.

The way to beat out the competition is service. You can't give your money away. You can't pay 20 to 25 cents per pack commission and show a profit.

Other operators and corporations pay 16 cents to 18 cents per pack, but their down time can be one week to ten days. We give 15 cents, but our machine's down time is only five to six hours maximum.

We have 75 units within a 100 mile radius. We have nine route people who go out every week working cigarette and vending machines. We do preventative maintenance (check pack-pushers and coin mechs). We know what each location sells and stock the machines accordingly. If a location runs out, we service it within 15 minutes to five hours maximum. We keep records of location preferences in case a routeman is sick or off. I break routemen in personally. They travel with me for one month. In seven years I haven't had a turnover of over three people.

Pat Carrione
Executive Vice President
S & S Automatic, Inc.
Norwalk, Connecticut

It is no more lucrative today than it was ten years ago when there were more sales but less profit. Today, there are fewer sales but more profit.

We are vending at \$1.50. The more coins you need, the less likely people will have enough change in their pockets and many locations don't like to give change. The proliferation of brands (from six to 500) and all the anti-smoking campaigns have hurt business.

We are full-line operators. Certain parts of the business such as soda, coffee, and cigarettes have picked up, but cigarettes are still down from prior years. In the past 20 years, we have lost a lot of vending business in general. A lot of locations have gone to retailing. There were not as many 24-hour convenience stores as there are today. At one time, cigarette machines were 20 percent of all vending sales. Today, they are seven or eight percent nationally.

Fifty percent of my business is cigarettes, although I have decreased the number of cigarette machines by 20 percent over the last five years.

A lot of gas stations feel they make more money on cigarettes than they do on gas. Many locations, like gas stations, now sell cigarettes over the counter.

In this area, locations discount cigarettes by selling 20 percent less than machine price.

Profit is better today than it was because of the spread. Maybe we shouldn't be selling cigarettes at \$1.35 to \$1.40 but, because sales are not what they should be, we have to. A lot of industrial locations are not interested in making a profit, so they lower their prices. Our reputation speaks for itself. We are well known, from longevity in the business to service.

Chuck Queen
President
Abraxas Vending Inc.
Frisco, Colorado

I've been in it for four years. It's lucrative enough for me. Cigarette machines are 20 percent of my operation. Part of our success is that we are in a resort area, and the price is not as critical as in a city. We are selling for \$1.50, so we are able to make a decent profit. When you are on vacation you don't worry about every little nickel.

Basically, the secret is keeping the machines attractive and working properly and servicing them immediately. We do everything possible to make sure the machines are working well. This is not a big operation with only 27 machines. One man checks, stocks, and

repairs them weekly. During the ski season we go into some locations more than once a week.

The volume the machine does is the key. If you don't sell many cigarettes, it won't work out. If cigarettes are marginal, we can focus on other machines. It is a necessary part of certain locations and makes enough profit to make it worthwhile. We've had to shop to get the best price from wholesalers and have had to raise our prices on the retail end of it.

At \$1.50, we make 45 cents per pack. We were making 25 cents per pack. I don't know if sales will go down because of price increases, but if so, the price increase will make it worthwhile.

Even \$1.50 doesn't seem so outrageous when you consider a person will pay \$3.50 for a drink that lasts five minutes, and a pack of smokes will last the whole day.

Gaines C. Butler
Vice President
Metro Distributors, Inc.
Decatur, Georgia

It is not as lucrative as pinballs and pool tables. You make around ten percent concessions and everything else. Cigarette machines make up 15 percent of my total operation.

Some secrets of our success are that we offer the highest commission possible, we keep a clean machine, update our cigarette tabs, keep the highest selling brands well-stocked, and we provide fast service.

Prices have gone up more in the last three years than the previous 20 years because of taxes and tobacco companies. The average vend price is \$1.25, but each location is different on commission.

We have a variety of locales. We handle games and music, and vending needs, so we give better service. All of our video technicians are taught to work on cigarette machines. If they are servicing video machines, they can service cigarette machines also. Therefore, down time is minimal, less than one hour per year. No machine is out longer than eight hours. Preventative maintenance eliminates repeat service calls.

We have two account managers who check the cigarette machines for problems. These guys also collect from music and games and do sales calls. They are our biggest critics. We have two route people who stock machines and five service people who repair and do preventative maintenance.

We have not lost clients to retail over-the-counter operations, but have lost some to companies that have sold the location a bill of goods by claiming they can own the machine after making payments on it for a number of months. Of these, we recaptured 14 accounts who found that the deal wasn't as good as they thought.

After the location owned the machines, things didn't work out because they weren't professional vendors. They didn't know the proper way to make money at it and knew nothing about volume buying.

We have guys trained to accurately and efficiently fill a machine. He can tell by pack sales what should go in the machine, whether full flavor, light, or menthol. We

regulate the sales. Our routeman knows what cigarettes sell and he must get permission from our main office to make any changes in stocking the machines. Each machine is stocked differently, and there is a record in the office of everything that is done.

Dennis Meyers
President
AVC Inc. (Automatic Vending Co.)
Freeport, Illinois

It's not lucrative because manufacturers have raised prices to where it is no longer worth the time and effort. They are not providing the operator enough incentive to secure more locations. Customers can go to a grocery store and buy cigarettes for 80 to 85 cents per pack, but an operator has a fixed overhead (maintenance, commission, etc.), so he has to get \$1.25 to \$1.35 per pack to break even.

Promotions allow so much per year for brand placement, but it is still not enough.

Every three to six months they hit you with another increase of two cents per pack or 20 cents per carton. Your operation must simply absorb it or increase cigarettes by a nickel per pack. Operators often go through two increases before they raise the price in a machine. This means the tobacco companies are benefiting as soon as the increase takes place, but the operator has to live with it.

Late night groceries and cut rate gas stations will sell cigarettes at cost, 80 to 85 cents, just to get people to buy something else. That hurts us. People won't spend \$1.25 if they can get a pack next door for 80 cents. Manufacturers are only interested in numbers, and you can't blame the consumer for wanting to buy cheaper elsewhere.

We charge \$1.25 in our area. And even though we don't have city tax, only municipal, we're lucky if we make 8 to 9 cents per pack. It's not much considering the cost of equipment and inventory around 300 packs per machine.

At one time we had 130 to 160 machines. Now we are down to around 40, roughly 10 percent of our operation. We keep them just as a convenience. We have some locations that may have 40 pieces of equipment and want eight cigarette machines. Other locations have had cigarette machines taken out and don't even think about replacing them.

We see cigarette machines as a necessary evil, not a profit situation at all. If I had to rely on cigarettes for anything I would fold it up. Tobacco just doesn't make it anymore, when you have to compete with retail outlets that are selling at 80 cents per pack.

Another thing that has hurt us is all of the news media's emphasis on the smoking bans. Within the last two to three years, we have had locations remove their cigarette machines as the first step at banning smoking completely. They feel that if people are desperate to smoke, they will either bring their own or talk themselves into quitting.

If cigarette machines were profitable, I would probably have a thousand of them. •

PLAN NOW TO ATTEND AOE '86.

IS PINBALL REALLY BACK? FACT OR FALLACY

By Roger C. Sharpe

I've heard the rumor about the supposed rebirth of pinball; and, although I would like to believe somehow it doesn't ring true.

I'd really like it to be true, but something is standing in the way of a

frozen and no longer offer any rebounding action, or the flippers may be so deteriorated the player can't make important shots.

So, the terrific bargain is instead a machine that has no right to be in

Doesn't it become counterproductive to offer players the same old machines? Isn't that what happened to video games when players refused the worn out legacies of another age?

Part of this dilemma is faced by pinball manufacturers who are fighting a losing battle against past glories. There is definitely a crisis that cannot be ignored when a successful game like *Space Shuttle* has a hard time meeting a decent production run.

Although barometers are revealing a pinball comeback, pinball manufacturers are hurting because the industry is not supporting new product introductions. This is painfully apparent when considering the limited number of new models introduced during the past nine months.

Premier, struggling to gain a foothold and better understanding of what players want, has introduced *Ice Fever*, *Chicago Clubs Triple Play*, *Bounty Hunter*, and probably at least one or two more before the year is out. But, that's still only four or five different models at a time when market conditions are supposedly on the upswing.

At Bally the story is much the same with *Spy Hunter*, *Black Pyramid*, *Fireball Classic*, and *Eight Ball Champ*. At

Only about a dozen new models offered during 1985 is a sad commentary on market resistance.

full-fledged pinball revival. Pinball must now compete with itself for survival and success. Operators are providing just enough for what the traffic will bear. This approach takes advantage of a new pinball audience.

Since the players usually aren't knowledgeable, discriminating, or demanding about pinball, many locations are keeping older machines longer and not properly maintained, so new equipment entering the marketplace is being stifled.

And though there are pinballs that deserve to be enjoyed by a new generation of players, it's a double-edged sword when evaluating the impact this business practice can have.

First, mixing the old with the new is great unless it's taken to an extreme. Second, is the problem of not properly maintaining equipment. The dilemma here is operators shopping and servicing games without experience. They think they're getting a bargain on five or six year old equipment. However, this usually means the playfield components are past their prime and often patched together, drop targets have been replaced by ones that aren't close to the originals, a missing target has never been replaced leaving a gaping hole, the thumper bumpers are

operation. But these operators don't really understand the damage they're doing. In one place, where pinball might have had a decent shot, the only models available were older pins in deplorable condition. The owner had passed by the newer *Firepower II*, *Space Shuttle*, *Ice Fever*, and others to milk all he could from his clientele on older ineptly maintained games. Even game rotation would have suited this place better than the same three games for over six months.

Another place is a classic example. A large operation featuring the latest video games, with a wall of pinball machines with pitted playfields, burned out bulbs, stretched out rubbers, and other major problems, showing the operator's total lack of sensitivity to upgrading his equipment.

The pity is that the time is right for widespread acceptance and recognition of pinball as a challenging form of coin-operated leisure time entertainment.

Eleven machines, a testament to the past, ignoring the present and future. And that's the issue. How can you prove to an operator like this that he might increase earnings and player loyalty if he adds a new game or two.

Williams, *Space Shuttle* is staggering through a lengthy run followed by *Sorcerer* and a new release, *Comet*. *Capt. Hook*, *Agent 777*, and *Lady Sharpshooter* have been Game Plan's only choices.

Only about a dozen new models offered during 1985 is a sad commentary on market resistance.

I've noticed a greater penetration of flipper games into the overall mix of coin-op equipment, but the increase in volume is more used pieces than new. Unfortunately, the paradox is that players don't know there's anything better.

The risk of investing time and money in research and development is illustrated with *Space Shuttle*, with limited acceptance. There's not much incentive for other manufacturers to pull out all stops and produce what they're capable of doing. Just when the market needs innovation in pinball design, all that may be left to fill the demand is holdovers from a past era. The pity is that the time is right for widespread acceptance and recognition of pinball as a challenging form of coin-operated leisure time entertainment.

On the brighter side is the approach being taken by operators such as Steven Epstein, owner of New York City's Broadway Arcade. A staunch supporter of pinball, and owner of a prime test location, Epstein has adopted new methods for boosting earnings.

Epstein's efforts have been rewarded in the cashbox and in customer loyalty.

Epstein has promoted his operation with major press coverage, while establishing successful pinball leagues. Epstein is gearing up for a more comprehensive program in the fall.

Almost any location can enjoy success following Epstein's pinball league program with the infusion of new equipment.

Taking a critical view of the existing market and what the trends appear to be, it's difficult to get excited by the rhetoric attached to the resurgence of pinball. It's a fallacy that could destroy the commitment shared by the pinball manufacturers.

The acid test will be the product introduced in the next few months. Will the manufacturers be willing to take risks in order to generate excitement, interest, and sales? This next push will feature some special models that might initiate a turnaround.

The preliminary indications are that pinball finally might be on the verge of recapturing the confidence of operators, distributors, and players. •

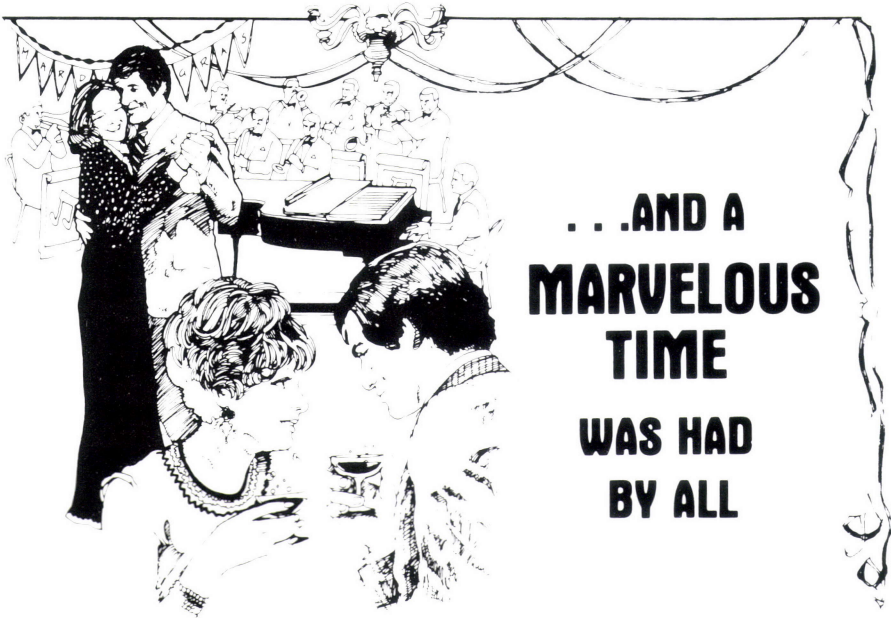

...AND A
**MARVELOUS
TIME
WAS HAD
BY ALL**



AND
MARDI GRAS

NEW ORLEANS FEBRUARY 6, 7, 8, 9, 1986

**SHANGHAI
KID**

In
California



C.A. ROBINSON & COMPANY
2891 W. PICO BLVD.
LOS ANGELES, CA 90006
213-735-3001 Ira Bettelman

memetron
INC.

**SHANGHAI
KID**

In
Dallas



SOUTHWEST VENDING SALES
2455 IRVING BLVD.
DALLAS, TX 75207
214-638-7002 John Gatens

memetron
INC.

**SHANGHAI
KID**

In
**North
Carolina**



BRADY DISTRIBUTING CO.
4308 WILMONT RD.
CHARLOTTE, NC 28208
704-525-8130 Jon Brady

memetron
INC.

**SHANGHAI
KID**

In
Minneapolis



LIEBERMAN MUSIC CO.
9549 PENN AVE. SOUTH
MINNEAPOLIS, MN 55432
612-887-5300 Steve Lieberman

memetron
INC.

FRANK'S CRANKS

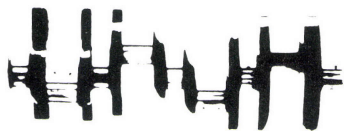

By
Frank "The Crank"
Seninsky

Our games can generate advertising revenue

I believe there are things about our industry that are dragging us all down. If coin-operated games are to recapture their potential share of the entertainment dollar, major changes must take place.

One thing I've learned in 17 years of operating, is that there is a core of operators who are survivors. They will remain in business while manufacturers, distributors, and other operators come and go. These operators are cunning and street smart. They are often underestimated by the manufacturers, who are just beginning to understand with whom they are really dealing.

It's to these operators, who read this column religiously, that I say, you rarely look to the future of your industry (it's your industry—you built it). We all have a tendency to grab all we can today and disregard what's happening around us shaping the future.

For those operators, distributors, and manufacturers still committed to coin-op games, 1986 will be a crucial year, an awakening. It's obvious that system games will dominate, regardless of how many dedicated hit games are produced. Don't misunderstand; there's a place for dedicated games. I'm glad Data East, who started the system concept, is producing hit games, even though it is only producing dedicated games. The statement that *system games will dominate* is even more significant if you can, as an old cliché goes, "see the forest for the trees."

Things clicked for me when Kramer Manufacturing asked me to help put together its *LA Trivia* pro-

motion with Anheuser-Busch, the producers of the new LA (low alcohol) beer. This was the first time an outside advertiser saw the advantages of using game monitors to promote their product for a three to five year advertising campaign, and made a commit-

*Advertisers
will see
the advantages
of using
game monitors
to promote
their products.*

ment to one of our manufacturers. Hats off to Kramer and the other trivia game manufacturers who are also putting together similar relationships with noted beer distributors.

Two years ago Bally Midway paid royalties to Budweiser in a feeble promotion attempt with its *Tapper* game, an average video with a limited run and a life cycle of several months at best. Other game manufacturers also paid royalties to be affiliated with a star; remember *Captain Fantastic*, *Power Play*, *Ali*, *Rocky*, etc. This practice of game producers paying

royalties adversely set an advertising precedent that is finally being reversed.

With the proliferation of system games, including trivia games, that are easily updated, a manufacturer can assure an advertiser that the hardware will be on location for a long time.

This is the key! Advertisers will pay manufacturers for this form of advertising, and the operator will get a rebate for putting the system on location. Operating system games in a few years will be similar to cigarette machines. Cigarette companies pay operators for each column brand and for all advertising signs placed in the machines. This is why I got involved with *LA Trivia*. This is why a company like Nintendo should put together advertising packages with giant advertisers that will reduce the costs of games to operators.

This is the next giant step that our industry will take. Although there are other forms of advertising that reach the public faster, our industry is one of the cheapest, yet efficient, means of advertising available. Updating routes with system games (forget about bootleg games) is the smartest thing an operator can do over the next few years. And insist on five-year exclusive contracts. Later I'll explain how this ties in.

Next is the distributors' role in the plan. Many operators don't realize that the distributor is very important to the operator's survival. I've seen all aspects of this industry and I'm going on record by saying that without a strong distributor network, the operator, in his present structure, is doomed. If that's all you get out of this

article, then you really understand this industry.

A distributor carries out functions that a manufacturer isn't currently capable of or yet willing to do. These include: (1) financing operators prudently, although some distributors haven't learned this yet; (2) stocking spare parts, boards, and games from several manufacturers; (3) cautiously competing for locations with operator customers; (4) selling games into other distributors' territories, which tends to keep prices down; (5) providing operator service which as technology improves, becomes less important; (6) putting incentive boards into old game cabinets and selling these conversion games for \$995 to operators who, as I said, are smart and know exactly what's going on; and (7) keeping the manufacturers from learning the operating business, keeping our industry in chaos.

Operators, isn't it worth spending a few extra bucks per game to see that the distributors survive?

What will happen to the distributors when the strong manufacturers decide to sell direct to operators? We saw the results when Centuri, a financially troubled manufacturer, went this route. But now I'm talking about those that are not in a similar financial bind. Take my word, it won't be long before these capable manufacturers are jockeying into position to sell or lease direct to the cream locations. With improved technology, service will soon be a minor concern for location owners. Be glad you took the time to secure those five-year contracts. The only way I can see to keep strong manufacturers honest is to insure we have the legal right to put other manufacturers' software into our existing system hardware. Let free enterprise protect our investments.

Bootlegging counterfeit boards is one of the major problems facing our industry today. In the August 1 issue, Mike Shaw wrote a fine article titled "Counterfeit Catastrophe" and I commend him. I've always been against bootleg games, not because I am a crusader, but because common sense tells me that bootlegging is ruining my operating business.

While awaiting the outcome of the FBI trials in Atlanta, I hope that more operator associations will help clean up their areas, as has Ohio, and see that pirate games are climbing the list

of FBI priorities. I admire Glenn Braswell, executive director of AAMA, Peter Kopke, AAMA's in-house council, and Bob Lloyd, president of Data East, and of AAMA, for trying to curb the rampant counterfeiting.

I strongly feel that the quickest way to stop the bootlegging is for the manufacturers to keep prices down. Nintendo has the right idea. Who would bother to copy a \$250 kit? Data East sells only dedicated games, and that has encouraged the bootlegging of Data East games.

Crank's plans

This summer I have been getting phone calls and visitors seeking my advice or just looking at what Alpha-Omega is up to. New companies often send or bring their prototype games asking me to write a review or point out necessary design changes to improve the produce. Often these products don't impress me. However, one that did is *Pop-a-Shot* basketball, which I will be reviewing in the next issue. I put one on location last week and, with a few design changes, made by Marty and Kenny Schwartz of Stanley's Sportland Arcade in Wildwood, New Jersey, the game is now doing over \$600 a week.

Besides working with Anheuser-Busch, Alpha-Omega recently formed working partnerships with several large operating companies to provide expert service; we are working with firms outside the industry who are interested in advertising through video system games; sell reconditioned games, new games, and novelty pieces that are not handled by local distributors; and I am looking, as always, for new types of games that offer a good ROI and can increase my operating revenues.

Why many large operators haven't been able to run video games profitably is because they are not experts in deciding what games to buy, how many to buy, and when to sell used equipment to get the best return on their investment. I consider myself to be knowledgeable in this area. Alpha-Omega has been able to turn large profits year after year without resorting to operating bootleg or gray area games. That's quite an accomplishment.

I'm available at 201/287-4990 to answer questions to help operators.

As always, keep cranking! ●

YOU CAN BUY THE BEST TOKENS FOR LESS!



CHECK OUR PRICES AND SEE!

HOFFMAN & HOFFMAN tokens are minted under the most rigid quality control standards. We match Old World craftsmanship with advanced technology. HOFFMAN & HOFFMAN has the best prices, fastest delivery, and highest quality tokens in the nation.

CUSTOM TOKENS SHIPPED IN 10 DAYS

HOFFMAN & HOFFMAN
P.O. BOX 896, CARMEL, CA 93921
800-227-5813
IN CA 800-227-5814

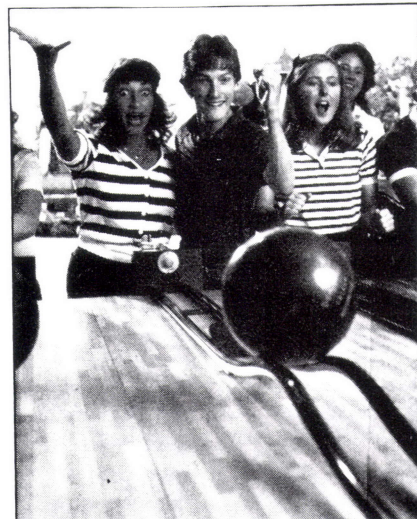

Bowler Roller is the perfect addition to your gameroom. We bring you great games and more.

Since 1968 we have been developing *merchandising programs* and equipment. If you are interested in tickets, prizes, redemption centers and merchandising methods give us a call.

The makers of Whac-A-Mole
Manufactured in U.S.A. since 1970

Bob's Space Racers, Inc.
427 15th Street
Daytona Beach Florida 32017
904-677-0761

SPECIAL NOTICE

purchase your used equipment from NEW ORLEANS NOVELTY CO.

In business for 50 years!

International reputation for selling the finest used videos, flippers, & amusement games available anywhere.

EACH & EVERY GAME BEAUTIFULLY REFINISHED LIKE NEW BY EXPERTS
All games authentic legal factory models
GET ON OUR MAILING LIST FOR OUR LATEST PRICE BULLETINS OR CALL
Rose, Eddie, or Jean for latest prices
3030 No. Arnoult Road
Metairie, LA 70002 * 504/888-3500

Deferred compensation for retired business owners

Many successful, closely held businesses began with a founder who put in many unpaid or low-paid workdays in the start-up years. Sound familiar? Then here's a case you'll like. The court held that a business owner can collect, even after his retirement, the compensation he denied himself in those early years (*Yeomans*, DC 111).

First the facts. The owner of a closely held business reduced his salary on occasion to keep his corporation adequately capitalized. His forbearance paid off. The business expanded over an 18 year period to over \$2 million in assets. With an eye toward retirement, the owner drew up an agreement between himself and his corporation, agreeing to retire by the age of 71. The corporation agreed to

pay him \$20,000 annually after retirement for consulting services. A resolution of the board of directors approved this deferred compensation agreement.

The owner transferred his stock ownership in the corporation to his son over a two-year period. With his son firmly in control of the corporation, the founder retired. The corporation deducted deferred compensation payments. No way, said the IRS, claiming the payments were for the transfer of the founder's stock to his son.

Although the court agreed that payment for the owner's stock may have been part of his motive for the payments, it did not believe it to be his primary motive.

The court, impressed with the retired owner's consistently conservative approach to his business, agreed that the post-retirement payments were deferred compensation. Also, the court found that the payments were reasonable because they were in line with deferred compensation rates being paid by others at the time the agreement was made, and the owner had denied himself adequate compensation in the past, even though the company was financially strong enough to make such payments.

How can this case help the owner of a closely held business? It shows one way for you to transfer your business, help your children to run it after retirement, and guarantees you a retirement income. ●

Business lunches may not be deductible

The businessman's lunch, long used as a means of taking care of business, may now cause tax indigestion. According to a recent case (*John D. Moss, Jr.*, CA-7, 1985), the cost of a working lunch between company executives, where important business is discussed, is not necessarily tax deductible. The noose is further tightening around the neck of the three-martini lunch.

Here's the story. Partners, associates, clerks, and secretaries of a law firm lunched daily at the same restaurant. At the lunches, the firm's litigation was discussed. The attorneys reviewed pending cases with the head of the firm whose approval was needed for any settlements. Each

partner deducted his share of the lunch expenses as a business expense. The IRS disallowed the deduction, and worse yet, the court agreed.

The court noted that the daily luncheon meetings were necessary to conduct the firm's business, but that did not automatically make them deductible as ordinary and necessary business expenses. The court's logic is that personal activities, such as lunch, should not be awarded a tax windfall. To do so would entitle a commuter to a deduction for the cost of his commute because he happens to discuss business with a fellow worker during the trip. True, the activities may be related to business, but they are really a matter of personal choice.

However, the court gave examples of situations where a business lunch with co-workers could be deductible. And that's the crux of the logic behind the court's decision—the *frequency* and the *circumstances* of the particular working lunch situation controls its deductibility as a business expense.

In the example, daily meetings were too much for the court to stomach. But the court suggested that monthly lunches would be deductible. Clearly, an occasional meeting at lunch or dinner with one or more co-workers is deductible if business is discussed. Sorry, daily sojourns to your favorite eating trough or watering hole to discuss business may be pleasant, but the cost is not tax deductible. ●

HERE WE COME!



OWNED AND OPERATED BY *PLAY METER* MAGAZINE

GENE'S GUDGEMENTS

By
Gene
Lewin

Exidy's 'Combat' heads this list

More and more of the new games are coming out as conversions or systems. As operators get more choices of these types, the regular dedicated games make less and less sense to buy for a good return on investment.

Kicker/Konami

(Available as a conversion for any vertical raster game.)

Kicker is another Kung-Fu fighting type of game. The player has to kill off all the enemies to complete each level. The graphics are well done with lots of color and detail.

Kicker is another good game from Konami, but it is definitely not as good as *Yie Ar Kung Fu*. The Kung-Fu themed game is still good and the players have not tired of it yet.

Rating: 6—Should stay on the chart 16 weeks.

Combat/Exidy

(Available as either a dedicated game or a conversion for *Crossbow* or *Cheyenne*.)

As is obvious by the name, this is a war-themed game. The controls are the same as the previous games with the addition of an action button that does different things in the different scenes.

Although Exidy doesn't call it such, they have quite a system going.

(ROI) RATING SCALE

- 10 A fantastic investment. Move over *Pac-Man*.
- 9 Great investment. Should earn well and hold its value.
- 8 A good bet. Should pay off for you.
- 7 Not bad. Are you willing to take a chance.
- 6 Slightly above average. Only a good investment in a high volume location or as a conversion.
- 5 Just average. Better be ready to rotate quickly.
- 4 Below average. Closeout around the corner.
- 3 Pretty bad. I'm not buying any.
- 2 Don't waste your money.
- 1 Terrible. Not even worth playing.
- 0 They've got to be kidding. Buy pesos instead.

With three games, there is a lot going for it. The conversions are quite expensive, considering you have to give back the old logic board.

An obvious problem with that is there is no way to convert back to the old game if you wanted to. One way to do it is to buy each game as a complete game, and convert the games by taking the logic board, artwork, and gun assembly off one cabinet and

moving it to another game in another location.

It would be a nice touch if Exidy made the control panel removable. If they did that they would have a real good system going.

This will be another great earning game from Exidy. These gun games have tremendous staying power and keep earning for a long time. With the price on *Combat* lower than it was on *Cheyenne*, it is a great investment.

Rating: 9—Should stay in the chart for over a year.

Demolition Derby/Bally Midway

(Available either as a four-player island cabinet or as a two-player upright.)

The player participates in a demolition derby race and tries to disable the other cars. All players can play at the same time and can even join in during the middle of a game. The graphics are marginal, the only signs of damage to the cars are a damage meter and smoke coming from the radiator.

There is not enough detail to show dents in the cars.

This game will have high earnings, but they may not last long. It will be a good game if you have a lot of locations to rotate it to.

Rating: 6—Should stay in the charts for 20 weeks. ●

*With more good games coming out as conversions or systems,
dedicated games make less sense.*

MOS/FET & J/FET Circuit Design LCP

Editor's Note: The material below is a serialization of the Kurz Kasch correspondence course for electronics, designed specifically for the coin-operated amusement industry. This course is copyrighted and owned by Kurz Kasch of Dayton, Ohio, and its reprinting is being sponsored jointly by Kurz Kasch and Play Meter magazine. This material is authorized for publication exclusively in Play Meter magazine.

Lesson Fourteen: Flip-Flops

Lesson Fourteen – Flip-Flops. This lesson is a description and the design of flip-flops using MOSFETs.

FLIP-FLOPS:

A prime memory element in digital circuits (especially integrated circuits) is the **bistable multivibrator** or **flip-flop**. A flip-flop is a pair of gates cross-coupled in such a way that when one gate is on, the other is off providing a bistable output condition. There are several types of flip-flops each with letter designations such as T, JK, D, etc. The most common and perhaps the simplest is the **RS flip-flop** as illustrated by the two

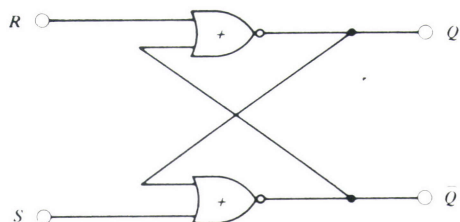

Fig. 14-1. Typical RS Flip-Flop Using Two NOR Gates.

Truth Table			
R	S	Q	\bar{Q}
0	0	(don't care)	
0	1	1	0
1	0	0	1
1	1	(forbidden)	

Fig. 14-2. RS Flip-Flop Truth Table.

NOR gates in Fig. 14-1. The R and S designate the **direct reset** and **set** inputs respectively, while Q and \bar{Q} are the bistable outputs. The positive logic truth table is shown in Fig. 14-2. Notice that a so-called **don't care** condition exists when both inputs are logical zero. This means that the state of the output cannot be predicted when zeros are simultaneously applied to the

R and S inputs. A **forbidden** condition exists when both inputs are logical 1. The circuit will tend to latch-up under this input condition.

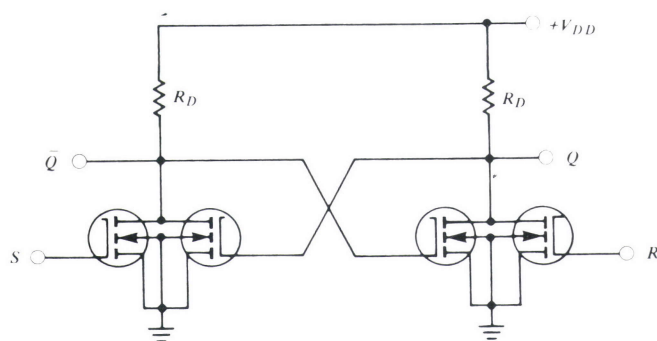

Fig. 14-3. A MOSFET RS Flip-Flop.

To realize this circuit with FET devices, two MOSFET NOR gates can be used as in Fig. 14-3. One of the disadvantages of this circuit when implementing into integrated form is the large value of drain resistance that is necessary. Since large values of resistance take up proportionally large surface areas on monolithic substrates, the number of circuits (as in Fig. 14-3) that can be built on a given surface is limited to a small number. To allow small drain currents which are required for MOSFET gates and at the same time reduce the surface area needed by the drain

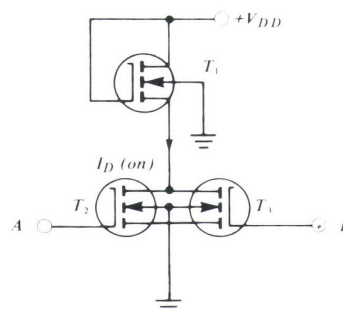

Fig. 14-4. Replacement of the Drain Resistor by a MOSFET Constant Current Source.

circuit, another MOSFET in a constant current source configuration can replace the drain resistor as used in the two input NOR gate shown in Fig. 14-4. If T_2 or T_3 is turned on, the source of T_1 is returned to ground which allows a constant drain current through T_2 and T_3 . Since this current will be the value of I_D (on) for each device, the need for a large drain resistor is no longer necessary. With the aid of T_1 , it is possible to simulate large values of resistances with a surface area no larger than one MOSFET. Fig. 14-5 shows another version of the MOSFET RS flip-flop with constant current drain loads. With this scheme, it is possible to build several hundred of these devices into one integrated circuit.

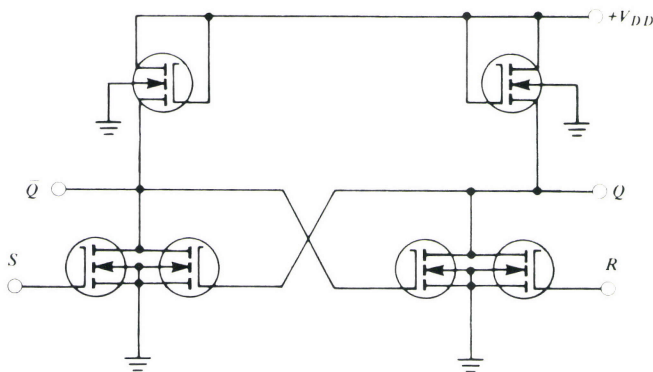

Fig. 14-5. Constant Current Source Version of the RS Flip-Flop.

Lesson Fifteen: Schmitt Triggers

Lesson Fifteen – Schmitt Triggers. This lesson includes the design of a Schmitt Trigger Circuit using a JFET as the input device.

SCHMITT TRIGGERS:

Another bistable circuit which is somewhat similar to the flip-flop is the **Schmitt Trigger**. This circuit is often used as a voltage sensing device and FETs are very useful when a high input impedance is required. Fig. 15-1 shows a JFET and an NPN bipolar transistor connected in a positive feedback loop to form a Schmitt Trigger.

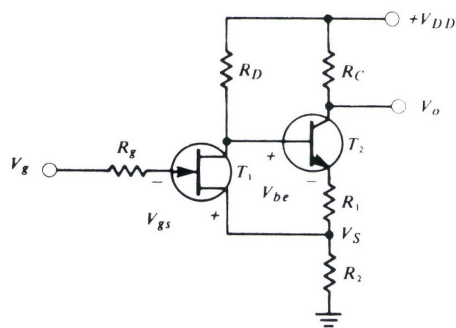

Fig. 15-1. JFET – NPN Schmitt Trigger.

When the input voltage V_g is at a value such that $V_{gs} \leq 0$, T_1 will be on and T_2 will be off as long as

$$I_D \text{ (on)} \cdot r_{ds} \text{ (on)} < V_{be} + R_1 I_e \quad (15-1)$$

where

$$I_D \text{ (on)} = \frac{V_{DD}}{R_D + R_2 + r_{ds} \text{ (on)}} \quad (15-2)$$

and

$$I_e = \frac{V_{DD}}{R_C + R_1 + R_2} \quad (15-3)$$

Any positive increase in V_g will not affect the circuit since T_1 is already on. However, as V_g decreases enough to allow T_1 to start turning off, T_2 begins to turn on and V_S begins to increase which helps to turn T_1 off even more. This source voltage **regeneration** causes a “snap” effect, such that as T_2 turns on, it aids T_1 in

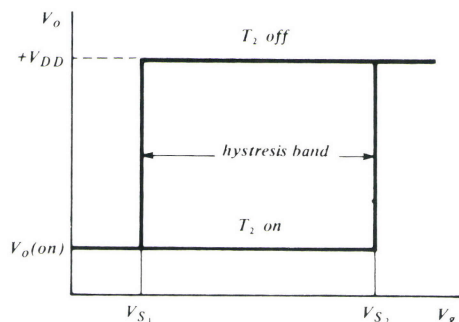

Fig. 15-2. Output Voltage vs. Gate Voltage Showing Hysteresis Band of the Schmitt Trigger.

turning off, which again aids T_2 to turn on. The condition for T_1 to start turning off is that

$$V_g \leq \frac{R_2}{R_D + R_2 + r_{ds} \text{ (on)}} \cdot V_{DD} = V_{S1} \quad (15-4)$$

Once T_2 is on, the input voltage must increase to

$$V_g \geq \frac{R_2}{R_C + R_1 + R_2} \cdot V_{DD} = V_{S2} \quad (15-5)$$

which causes T_1 to turn on and T_2 to turn off. These two voltage levels create a hysteresis band which is controllable by R_2 . Fig. 15-2 illustrates this band in a graphical manner. One of the less desirable features of this circuit is that when T_2 is on, the output voltage will be somewhat above ground. This output voltage is given by

$$V_o \text{ (on)} = \frac{R_1 + R_2}{R_1 + R_2 + R_C} \cdot V_{DD} \quad (15-6)$$

which is also determined by R_2 .

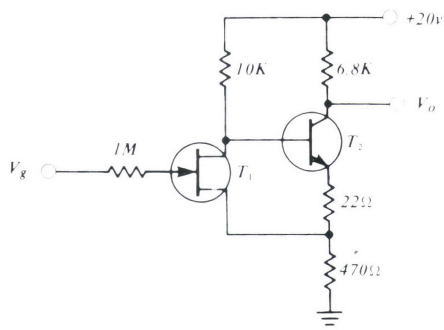

Fig. 15-3. Practical JFET – NPN Schmitt Trigger Design.

EXAMPLE 1:

Given the JFET-NPN Schmitt Trigger in Fig. 15-3, compute the voltage limits for the hysteresis band and the values of the output voltage. Assume the devices have the parameters listed below

JFET: (T_1)

$$r_{ds(on)} @ I_D = 0\text{mA} = 300\Omega$$

$$V_{gs(off)} @ I_D = 1.0\mu\text{A} = 1.2\text{v}$$

NPN: (T_2)

$$V_{be(on)} @ I_c = 2\text{mA} = 0.6\text{v}$$

for T_1 on and T_2 off,

$$V_{s1} = \left(\frac{0.470}{10.77} \right) 20\text{v}$$

$$V_{s1} = 0.875\text{v}$$

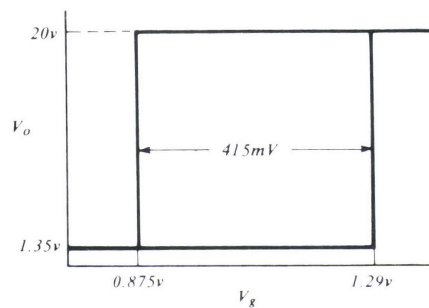

Fig. 15-4. Output Characteristics of the Schmitt Trigger of Figure 15-3.

To insure T_2 is off,

$$0.6\text{v} + \frac{22 \cdot 10^{-3} \cdot 20\text{v}}{7.292} > \frac{300 \cdot 10^{-3} \cdot 20\text{v}}{10.77}$$

$$0.6\text{v} + 0.06\text{v} > 0.557\text{v}$$

$$660\text{mV} > 557\text{mV}$$

For T_1 off and T_2 on,

$$V_{s2} = \frac{470(20\text{v})10^{-3}}{7.292}$$

$$V_{s2} = 1.29\text{v}$$

$$V_o(\text{on}) = \left[\frac{470 + 22}{7.292} \right] \cdot 10^{-3} \cdot 20\text{v}$$

$$V_o(\text{on}) = 1.35\text{v}$$

Fig. 15-4 shows the output characteristic which illustrates a hysteresis band of about 415mV. This circuit can be quite useful with photocell devices since the gate circuit will not load the photocell circuit.

LET US BE YOUR DRUMMER!

PLACE YOUR ADVERTISEMENT TODAY!

CALL: 504/488-7003





VAC-serv

AIR-vend, Inc., Mendota Heights, Minnesota, has announced the introduction of *VAC-serv*, a coin-operated vehicle vacuum service. The new *VAC-serv* offers a smaller, more functional cabinet design; a unique filtering system for easier cleaning; and overall heavy duty construction, making the *VAC-serv* practically maintenance-free and vandal-proof.

The new *VAC-serv* units can be used in convenience stores and service stations, where over 16,000 of the company's *AIR-serv* machines have already been installed. *VAC-serv* should also open new market opportunities in truck stops, car washes, and motels.

The *VAC-serv* has been designed to accommodate all safety regulations for mounting the units on gasoline pump islands. All electrical components are mounted at least four feet off the ground, making the unit attractive to truck stop locations, where safety codes previously prohibited use of similar products.

Maintenance of the *VAC-serv* unit is easy. A system of three cloth filters gather and hold all waste materials until the vacuum motor shuts off. The contents of each filter sack then automatically dump into the receptacle below. The receptacle can easily be removed for cleaning.

For added security, the *VAC-serv* also features AIR-vend's patented locking system with a new cylindrical locking bar. The upper chamber is protected by a second security door, and the newly enlarged coin box has a \$500 capacity.

The *VAC-serv* contains an Ametek/Lamb motor which, according to vice president of operations, Dick Jurek, "...was chosen for its power and few moving parts and durability."

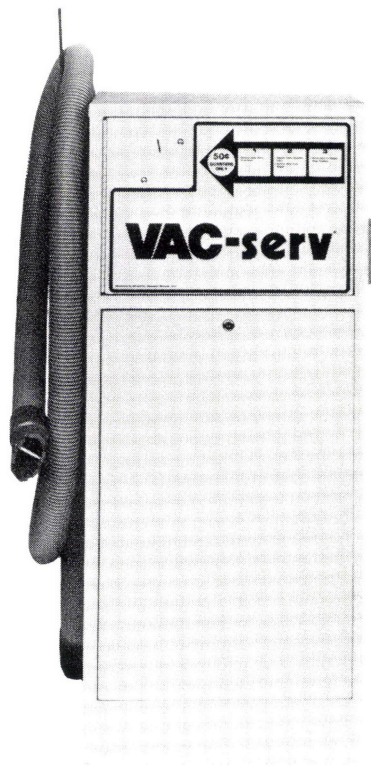

Indiana Jones and the Temple of Doom

Indiana Jones and The Temple of Doom, the blockbuster movie, is now the new third conversion game designed exclusively for Atari System I following *Marble Madness* and *Peter Pack Rat*.

"All the things that made the movie so fantastic are recreated in this exciting new video," said Shane Breaks, senior vice president at Atari. "Like the movie appealed to all ages, our testing has shown the game play draws a diverse range of players."

Operators are able to tailor this game for maximum earnings and play value with the following: Multiple coinage options allow eight different operator-selectable starting lives; new Auto High Score Table option automatically resets the game every 2,000 plays; the Multiple Bonus Life option lets operators adjust extra life conditions for every 20,000, 30,000 or 40,000 points, or sequentially increasing from 10,000, 20,000, 30,000, or 50,000 points; and a new Bonus Life feature allows operators to limit the total number of extra lives.

Indiana Jones and The Temple of Doom is the first System I game to use the system's speech capability to talk to players. Theme music and sound effects are from the movie.

The player is Indiana Jones in his quest to recover the sacred Sankara stone that once protected Mayapore, a remote village in India. He must also free the children from Mayapore who have been enslaved in the evil Pankot Palace, the secret worshipping grounds for the Thuggee death cult. Mola Ram, the ruthless high priest, has forced the village children to dig in the Thuggee mines for precious gems and the other missing Sankara stones.

Indiana Jones and The Temple of Doom is available in either a whole System I cabinet configuration or an easy-to-install game kit.



Gridiron Fight

Tehkan, Carson, California, introduces *Gridiron Fight*, featuring high resolution graphics and high-tech designing. Based on professional football, each player selects options from any type of formation and play in a battle of wits and strategy.

Player options include a roving fleet of foot monster men that can do spectacular feats and outdistance and maneuver any man on the turf.

The player is the mastermind coach utilizing many options from the hash marks on the grass to the spin of the pigskin. This is your chance to own and coach your own professional football team.

For more information, contact your nearest distributor or Tehkan, Inc. for referral.

Hang-On

Sega Enterprises, San Jose, California, introduces its new motorcycle racing game, *Hang-On*.

Hang-On is the first motorcycle racing video game. It features the realism of racing a real motorcycle.

Hang-On is five stages of game play, Alps, Grand Canyon, City Night, Seaside, and the Circuit. All levels of play are vividly depicted through high resolution video graphics.

Hang-On is equipped with four built-in stereo sound speakers, making the exhaust sound and the roar emitted when passing your competitors, sound authentic.



Marcom ST & Marcom XL

Advanced TeleSystems, Ltd. has begun field-testing its *Marcom ST* and *Marcom XL* private coin-op telephones in New Jersey.

The announcement was made by William J. Tighe, ATS's senior vice president of sales and distribution.

"We've placed our *Marcom ST* and *Marcom XL* phones at 25 test locations offering a wide variety of usage conditions," noted Tighe. "The two models have already passed six months of rigorous laboratory evaluation. This test will be the final step prior to full production. At the same time, we'll be conducting surveys among users, to ensure that the public is satisfied with the features, operation and esthetics of the phones."

With the results of the field tests becoming available by mid-October, ATS expects to be in full production of the two phones by early November and to begin shipping against current orders by November 15.

At first inspection, the company's *Marcom ST* and *Marcom XL* are similar to standard pay phones. However, they offer more features and need only minimal servicing and maintenance, the company claims. The *ST* is designed solely for coin-operation, while the *XL*, a universal phone, will accept both coins and credit cards, including VISA and MasterCard.

ATS maintains general and programming offices in Brookings, South Dakota, with production functions handled in Springfield, New Jersey. The company also has technical laboratories in California, Colorado and Arizona.

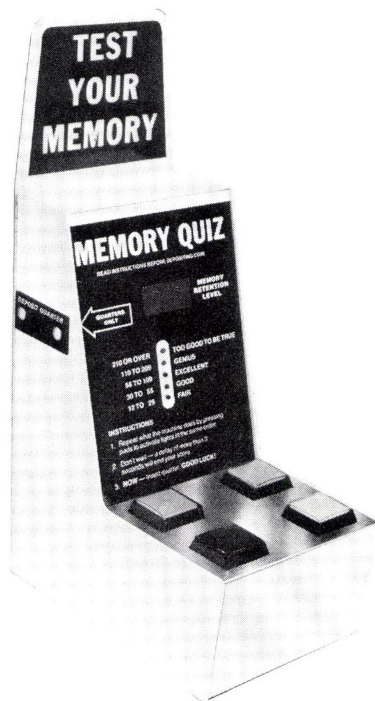

Memory Quiz

Adrian Enterprises of Randolph, New Jersey, has introduced *Memory Quiz*, a compact, 25-cent vend unit designed to appeal to adults as well as younger players.

Four colored pushbuttons test a player's memory retention level. The lights, each accompanied by a special tone, flash on in random sequence.

Each time a player successfully repeats the sequence by pushing the buttons in the same order in which they lit up, one more light is added on.

A wrong move or a three-second delay results in a raspberry sound and the end of play.

Players try for high scores and skill level.

A compact cabinet design, (15 inches by 8 inches by 11 inches), allows this unit to be placed in many locations where larger machines won't go. It can be mounted on a pedestal, requiring only one square foot of floor space, or placed on a counter top.

Memory Quiz features a sturdy coin box which holds over \$350 in quarters. The cabinet is made entirely of welded steel and the playing surface is stainless steel for long life.

The company is offering operators a first trial unit with a 30-day money back guarantee.

For more information, call 201/377-6946 or write 49 Radtke Road, Randolph, NJ 07869.



Generation II

DLL Com Con, Inc., a consulting and engineering firm in central New York, has completed development and is presently marketing and manufacturing its first coin-op telephone, *Generation II*.

Generation II is a line-powered, true pre-pay, fully programmable unit with answer supervision, and voice simulated instructions. It accepts nickels, dimes, quarters, and is capable of timed local and long distance calling.

The inside components are completely modular giving the telephone the capacity to be upgraded.

DLL Com Con is in the process of setting up distributors throughout the United States.

For more information, call 607/257-0333.

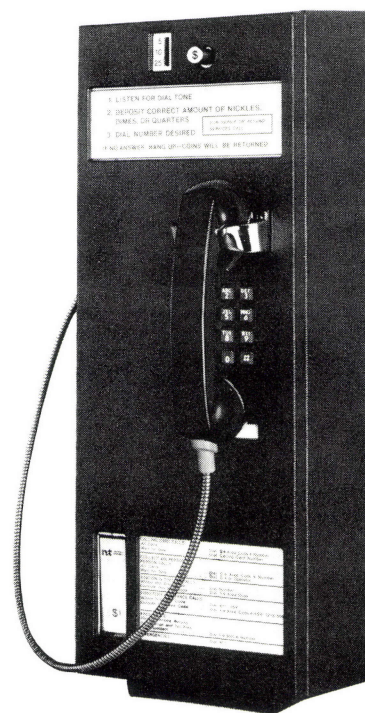

Aids to the Trade

Multiple switches

CEI's new XL150 series of multiple output switching power supplies pack over 2W/cubic-inch in an 8.0-inch by 4.6-inch by 1.9-inch package. Dual, triple, and quad output models are available. A MOSFET forward converter design and 100 kHz operation enables these switchers to operate up to 85 percent efficient.

Load regulation is still +/- five percent on the primary output and +/- one percent on the remaining outputs. Line regulation is +/- .5 percent over both the 90-135 VAC and 180-270 VAC operating ranges. Cross regulations is limited to +/- .5 percent maximum on all outputs.

The primary and secondary output voltages are adjustable, and have independently adjustable pots for current foldback short circuit settings. The primary output is generally +5V at up to 20A with a 4A minimum load typically required. The second output can be either +5V, +12V, +15V, or +24V, capable of surges up to 50 percent above rated loads for disk drive startup. The third and fourth output are floating, at up to 2A.

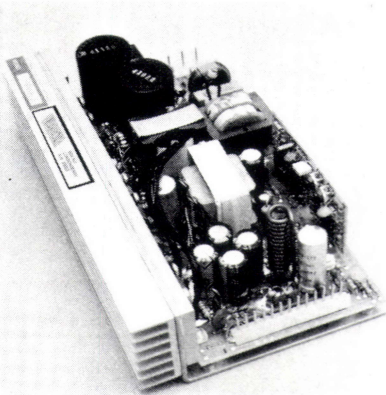

Noise and ripple are limited to 25 mV RMS, measured at the outputs. Hold-up time measured at 100 VAC, full load, is typically 25 ms. Transient response during a 50 percent to 100 percent load change is 500 μ s with a 30 mV deviation. O.V.P. and remote sense are standard on the +5V primary output. Available options include an A.C. OK signal and remote shutdown.

For more information, contact Paul Iverson, Sales Manager, CEI Corporation, P.O. Box 501, Londonderry, New Hampshire 03053. Telephone 1-800-DC POWER.

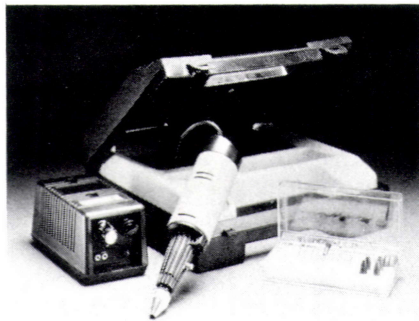

Drilling system

The Automated Production Equipment Corporation's Model SRS 020 miniature drilling system provides for all drilling, grinding, and polishing of PCB's during repair operations.

Model SRS 020 includes a variable regulated power supply and features a precision miniature hand held drill, with an infinitely adjustable 3/16-inch, three jaw chuck.

A full complement of bits, burs, and abrasives is also included. Model SRS 020 is packaged in a durable high impact plastic carrying case and is priced at \$139.

For additional information, contact Automated Production Equipment Corporation, 142 Peconic Ave., Medford, New York 11763. Telephone 516/654-1197.

Mailing list available

Rocklin Associates has available mailing labels for the coin-op amusement/vending industries.

There are eight major lists available, covering most areas of the industries. Said Rocklin's Wayne Coombs, "We doubt there are any other lists available that make so many options available. And we are sure that no other company uses the rental money to directly improve the list. We travel around the country visiting and telephoning the companies on our list so we can make sure each company is listed in all categories they operate in."

The following lists are available: Game Operators, Arcades, Billiard Operators, Jukebox Operators, and Vending Operators.

These lists are available individually or in almost any combination. Rocklin also provides customized lists.

Said Coombs, "We have been told that our lists are the best in the industry because we are selective. We make deletions where appropriate, just as important as additions. The rental fee you pay is used to finance this research which is an ongoing project. We are NOT a mailing list house with hundreds of lists, we offer a money-back guarantee, and our lists are compiled independently of any other mailing lists."

For more information, contact Rocklin Associates, 6520 Selma Ave., Suite 440, Los Angeles, California 90028.

DON'T MISS AOE '86 IN NEW ORLEANS MARDI GRAS WEEKEND

CLASSIFIED ADVERTISING

PHOTO MACHINES

WE BUY AND SELL

CHEMICALS, FILM, PARTS
BEST PRICES GUARANTEED!

ED HANNA

P.O. Box 29077 • Davie, Florida 33329
305/474-5888

Established 1951

LEGAL GALAGA for \$199

A.P. Engineering converts Atari
Dig Dug P.C. boards into Galaga
24 hour turnaround
1917 Huntington Street, Suite 3
Huntington Beach, CA 92648
714/969-1243

PAYPHONES—\$55

As extensions or add kit to require
coins \$98 Or ready to profit from
\$295 Genuinely F.C.C. registered!
Our electronics has been used in 5
other manufacturers Free 911
timed calls Also expecting entirely
self-programmable long distance
unit 608/582-4124 anytime

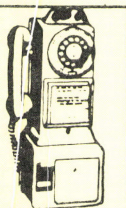

Video Connection CONVERSION KITS

Shang-Hai Kid (Hot kit) call
Konami® Rush-N-Attack™ call
Konami® Kicker™ \$775
1942 (Romstar) 795
Samurai (Taito) 775
Video Trivia (w/adult sex category) .. \$625
Magmax super low price
Nintendo VS. UniSystem call
Special Forces (fast kit* for D.K.).... 550
Up 'N Down 395
10-Yard Fight (fast kit* Defender) ... 395
Konami® Super Basketball™ 375
Tag Team Wrestling
(fast kit* Midway) 349
Do! Run Run 275
Exerion (like Galaga) 295
Street Heat (fast kit* D.K.) 349
Mario Bros. (fast kit* D.K.) 250
Bank Panic make offer
Greyhound 4 in 1
(fast kit* Defender) closeout!

*Fast kit includes:

P.C. Board and control panel
free wired for fast plug in.

VIDEO CONNECTION

930 Jeffrey Lane, Dixon, CA 95620
916/678-5189



In
North
Dakota

M.H. ASSOCIATES
1725 N. FIRST AVE., UNIT C
FARGO, ND 58102

701-237-4563 Gene Sieben

memetron
INC.

LOUISE'S HARNESS SHOP

Rt. 3, Box
Prattville, AL 36067

Video Game Harness and
Donkey Kong Monitor
Conversion Kit

Prices start at \$15.00

Write or Call

205/365-1841

ATTEND AOE '86 — MARDI GRAS WEEKEND

SATISFACTION GUARANTEED

P.C.B. and PERIPHERY

EQUIPMENT AVAILABLE AT FACTORY COST!

OUR QUALITY IS ALWAYS PERFECT.

SMALL AND LARGE ORDERS ARE SHIPPED

PROMPTLY. (SE HABLA ESPANOL)



SILVER STAR ELECTRONICS

465-72, DAPSIBRI-3, DONG.
DONGDAIMUN-KU, SEOUL, KOREA

TEL: 247-0931
TLX: K32288 YCPARK



In
Seattle

MUSIC VEND DISTRIBUTING
1550 FORTH AVE. SOUTH
SEATTLE, WA 98124

206-682-5700 Ray Galante

memetron
INC.

BUSINESS OPPORTUNITY

Coin-Op Amusement route
Northern Wisconsin
300 Machines in 64 Locations
Pool & Dart Leagues established
Excellent Gross • 8-Years Old
715/474-6748

WANTED

Lucky Crane, Boom Balls, Philadelphia
Skee-Balls, Triple Crane, Whac A Mole,
Muppet Video, Hydraulic Kiddie Rides,
Midway Shuffle Alley B W

WANTED Namco Shoot Away

M & P AMUSEMENT CO.
717/848-1846

WANTED

USED PC BOARDS
CALL FOR QUOTES

**ELDORADO
PRODUCTS, LTD.**

14816 Main Street
Gardena, CA 90248
213/516-9525

**READY FOR LOCATION SPECIALS!!!
WE SHIP ANYWHERE**

Asteroids	\$ 75	Frontline	\$495	Q*bert	\$595
Baseball (Atari)	195	Galaxian	295	Rock 'N Rope	295
Battlezone	195	Gyruss	595	Satan's Hollow	495
BurgerTime	495	I Robot	595	Space Chase	125
Centipede	395	Joust	495	Space Invaders	75
Champion Baseball	595	Jungle Hunt	395	Stargate	295
Congo Bongo	595	Jungle King	395	Star Wars	595
Dig Dug	495	Kangaroo	495	Tag Team Wrestling	795
Discs of Tron S/I	595	Laguana Racer	195	Tapper	595
Donkey Kong	395	M.A.C.H. 3 (S/D)	695	Time Pilot	495
Donkey Kong 3	595	Mario Bros.	595	Time Pilot '84	695
Dragon's Lair	595	Magazone	645	Tin Star	795
Elevator Action	695	Millipede	650	Track & Field	895
Exerion	495	Missile Command	195	Tutankham	295
Football (Atari) 2 PL	195	Pac-Man Plus	495	Xevious	595
Football (Atari) 4 PL	295	Phoenix	295	Zaxxon	395
Frogger	345	Popeye	395	Zookeeper	495

Used Pool Tables & Bumper Pool Tables—CALL

**We Buy and Sell Vending Machines
Anything Coin-Operated**

IFS, INC.

1102 Balsam Road • Waynesville, NC 28786

Mike or Jerry

Day: 704/452-0557 • Night: 704/648-1238

WE MAKE PACKAGE DEALS

FRANK'S CRANKS

FALL SPECIAL

**Video Trivia Kits with FREE extra game board, just \$595
with acceptance of a 6 month Trivia Updating Contract.
(That's a \$250 savings off regular prices!!!)**

CALL FOR DETAILS



Frank
"The Crank"

CONVERSION KITS

10 Yard Fight '85	\$ 399
1942	795
Crown's Golf	845
Cruisin	845
Kicker	Call
My Hero	845
Return of the Invaders ..	595
Rush 'N Attack	Call
TNK #3	845
Shanghi Kid	Call
VS. UniSystem plus kit ...	1095

Many Reconditioned Pinballs

SPECIAL

LA Trivia (to 15,000 questions)
\$695

CLOSEOUT

Kixx soccer game (new in crate)
\$1995

Call us today for complete
list on all new or
reconditioned videos
and pinballs.

ALPHA-OMEGA-SALES

Call Joe or Frank "The Crank"
201/287-4990

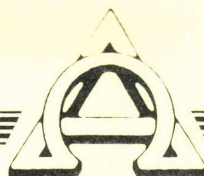

The Operator's First Choice

6 Sutton Place • Edison, NJ 08817

GAME AUCTION

Indianapolis, Indiana
 Saturday, October 26
 11:00 A.M.

OVER 200 GAMES
 Big Red Barn, Zionsville
 Exit 130 off Interstate 65
 10 Miles NW
 of Indianapolis

VIDEO • PINBALL
POOL TABLES • JUKEBOXES
 80 late model games
 from arcade closing

Auctioneer:
 Don Young, 317/769-3266

Sales Manager:
 Ric Stephan, 812/332-0568

2415 West Amherst
 Bloomington, IN 47401

Game Auction
Indianapolis, Indiana

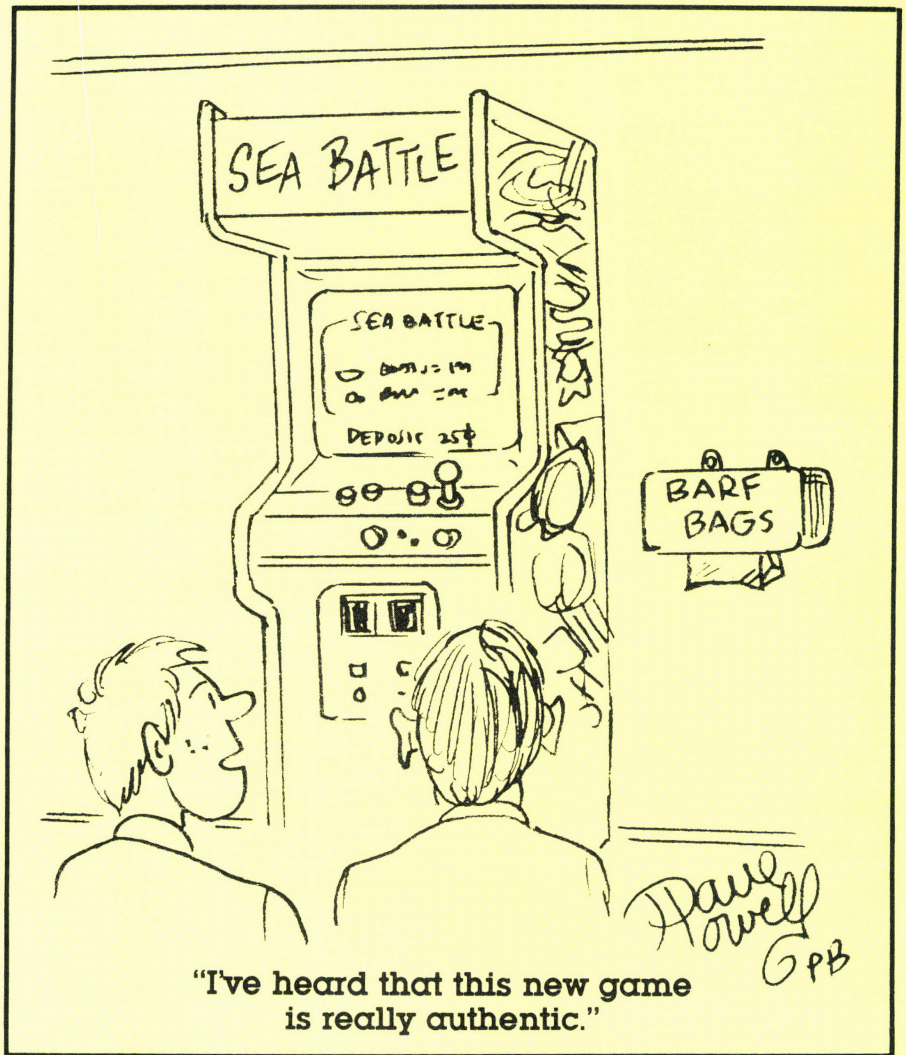

"I've heard that this new game
 is really authentic."

EPROMS
PROGRAMMED/COPIED
 Your Orig. \$5 • Our Blank \$10
 Rowe Cig. \$ Conv. up to \$4.00
NO PARTS NEEDED \$5.00
EZE • Box 24, Brooklyn, NY 11235

WANTED
Donkey Kong 3
P.C. Boards
 Will pay up to \$100!
818/308-3718
 or
818/308-3717



ADVERTISE
IN
PLAY METER
504/488-7003

PLAY METER CLASSIFIED ADVERTISING

Play Meter's classified ads are sold by inch (\$30 per column inch with a 1 inch minimum). Prepayment must accompany ad. You may pay by check, money order, Visa or Master Card. Deadline schedules are available upon request. Send ad orders and prepayment to: Play Meter Magazine, P.O. Box 24970, New Orleans, LA 70184. For more information, contact Joe VonderHaar 504/488-7003.

Write in or attach ad copy

Company Name _____

Name _____

Address _____ Phone _____

City _____ State _____ Zip _____ Total Enclosed _____

Visa Acct. No. _____ Expiration Date: _____

Master Card Acct. No. _____ No. of issues _____

Authorized Signature _____

VISIT US AT THE AMOA (BOOTH 2401)

We'll have some great Unadvertised Specials

CONVERSION KITS

Low Prices • Same Day Shipment
Free Technical Help Via Our Toll Free 800 Number

Bank Panic \$195	Great Swordsman 595	Pro Golf 295	UniSystem CALL
Champion Baseball II . . . 195	Kick Start 595	Son Son 595	Video Trivia 595
Cloak & Dagger 95	Kicker 725	Tag Team Wrestling 295	1942 745
Do! Run Run 195	Lizard Wizard 95	Ten Yard Fight 495	

NEW KIT RELEASES

Combat CALL	Indiana Jones CALL	Power Play \$895	Shanghai Kid CALL
Cruisin' CALL	Mach Force CALL	Rush 'N Attack CALL	TNK III CALL

VIDEOS

Asteroids \$ 75	Front Line \$495	Mr. Do! \$395	Space Dungeon \$395
Astron Belt 695	Galaga 750	Mr. Do!'s Castle 495	Space Invaders 75
Baby Pac-Man 350	Gorf 195	Mr. Do!'s Wild Ride 595	Space Tactics (s/d) 495
Bagman 495	Grand Champion (u/r) . . . 795	Monaco GP (s/d) 995	Spy Hunter (u/r) 1895
Battlezone 195	Gravitar 195	Monte Carlo 595	Star Rider (u/r) 795
Black Window 295	Gyross 595	Moon Patrol 595	Star Trek 195
Buck Rogers 495	H.B.'s Olympics 395	Ms. Pac-Man 395	Star Wars 595
Bump & Jump 695	Hat Trick 1795	1942 1095	Strength & Skill 695
Burgertime 395	Hogan's Alley 1495	Ninja Gun 1695	Subroc 3-D (s/d) 995
Centipede 375	Hyper Sports 995	Pac-Man 295	Super Pac-Man 295
Champion Baseball 595	Ice Climber 1395	Pac-Man, Jr. 495	Tac Scan 195
Chexx Ice Hockey 1095	Jungle Hunt 395	Paperboy CALL	Tempest 150
Circus Charlie 595	Joust 295	Pengo 395	Ten Yard Fight 895
Cloak & Dagger 495	Karate Champ 1895	Phoenix 195	Thief 495
Commando CALL	Kicker 1095	Pole Position 1595	Time Pilot 395
Congo Bongo 595	Kick-man 195	Pole Position II (s/d) 2195	Time Pilot '84 695
Crossbow 1895	Kung Fu Master 1995	Pro Golf 695	Tin Star 895
Crystal Castles 695	Lady Bug 495	Popeye 295	Track & Field 895
Demolition Derby CALL	Liberator 395	Professor Pac-Man 595	Trivial Pursuit CALL
Dig Dug 295	Looping 195	Punch-Out!! 1595	Turbo (u/r) 995
Do! Run Run 695	Lost Tomb 295	Q*bert 495	Tutankham 295
Donkey Kong 3 395	M.A.C.H. 3(u/r) 695	Quantum 395	Two Tigers 895
Dragon's Lair 745	M.A.C.H. 3 (s/d) 995	Rally X 395	TX-1 (new) 2695
Duck Hunt 1395	Major Havoc 795	Road Fighter 895	Up 'n Down 895
Elevator Action 795	Make Trax 195	Robotron 295	VS. Golf 1395
Excitebike 1395	Marble Madness 1995	Satan's Hollow 495	Wizard of Wor 175
Fax 595	Mario Bros. 595	Seicross 695	Wacko 695
Firefox (u/r) 995	Megazone 695	Sinistar 695	Xevious 595
Food Fight 595	Midnight Marauders 995	Space Ace 795	Zookeeper 495
Frogger 275	Millipede 650	Space Duel 195	

The Game Exchange

1289 ALUM CREEK DRIVE (our only office) COLUMBUS, OHIO 43209-0598 • (614) 258-2933

IN OHIO
1-800-848-1514

CALL TOLL FREE

OUTSIDE OHIO
1-800-848-0110

(continued from page 18)

out the room. Everyone thought he was losing his senses. In an article in one of the trade magazines, when I was still with Universal, I predicted the increase in kits and everyone thought I was crazy too.

But you don't have to be a visionary to look ahead and say: If we can make something that makes the operator a lot of money and is inexpensive to replace, then he will buy it. The drawback to the earlier systems was that they did not have any strong games. They were not able to compete in the marketplace. You can't put out a lot of three games in a ten marketplace.

Operators felt cheated when Sega/Gremlin



Bill Cravens takes time to talk with operators to find out their feelings on the industry.

professed the advantages of conversions but brought out its next game, Zaxxon, as a dedicated game. Will that happen today?

Nintendo has taken the best games from its home market in Japan. We have done in reverse what the home market was doing here. Coin-op games were being made into home but we take home versions and remake them into coin-op. We can get them cheap because the R&D has already been done. Of course, we have to make modifications but they are the best games available.

Isn't Nintendo introducing into the United States its home computer system, popular in Japan?

Yes, and I think it is a big mistake at a time when popular computers in the U.S. are selling so cheap and the market is falling. The video game bust was nothing compared to what the home computer industry's bust will be. After the first of next year, when they can't sell their inventory, it will be devastating.

Then what is the reasoning behind Japan's decision to introduce it over here?

They say: Let's try it! And of course, the Japanese have tried other things that have been right.

We talked briefly about other manufacturers developing games to fit in your hardware. However, will a time come when a company can design and manufacture games for systems without going through the system manufacturer?

No because certain parts of the system are patented. No one else could make software for our system, for example, without getting certain parts from us needed for the software to work.

So they would have to go through Nintendo to be able to design games for the VS. Systems?

Yes, because some of our patented hardware. And we use a different one in each game so they would have to get that part from us.

I relate it to a jukebox where any number of different companies can make records for the jukebox.

This is different because it's like we have the needle and in order to play those records they would have to come to us.

Why would an operator come out better by buying a system than he would using some of the old games he's accumulated over the years to install a kit. Then he would have a new game, it would cost less than buying a whole new game, and he wouldn't have to change the game.

What makes him think the kit he puts in his game is going to do any better than the game he converted? An operator can convert his old games to a system game. Then he has the ability to change it two or three times. That's what the UniSystem is all about. He doesn't have to buy complete hardware.



Bill Cravens was instrumental in the success of the Pennsylvania state show. Here he works an auction at the show.

Do you think systems are a long term solution or not?

I think they will be a segment of the industry. There will be other things. Just look at electronic darts. They are coming on strong. There are a lot of different ways to entertain people. Systems will be one of those ways. But I'll emphasize, it will be only one way. Operators must diversify and be able to react to this marketplace. And systems are a part of that marketplace. Just like in the video boom days when everyone was making the same game with only minor variations, all of a sudden the people weren't entertained anymore. So it takes more than one thing to make this a successful industry. ●

IN STOCK!
UPRIGHTS, C'TOPS
KITS

TRIVIA WHIZ

The TOP EARNING Trivia Game in all of coin-op
NOW AVAILABLE FOR THE
FIRST TIME!
SINGLE CHIP REPLACEMENTS
LESS THAN \$25.00 EACH

POP-IN

WHIZ
CHIPS

WITH MORE QUESTIONS AND CATEGORIES THAN ANY VIDEO TRIVIA

ALL NEW 10,000 QUESTION SET

**52 CATEGORIES
IN ONE GAME**

PLUS ... SEX TRIVIA
NEW EDITION

COMING SOON ★ 19" MONITOR UPRIGHT

merit industries inc.

P.O. Box 5004, 2525 State Rd.,
Bensalem, PA 19070

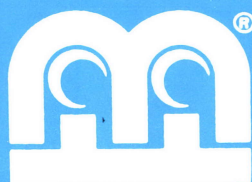

© Merit Industries 1985

Phone Toll Free

1-800-523-2760

IN PA

215-639-4700

GET THAT OLD  GREY DOG,

AWAY FROM YOUR WALLET!

■ THERE IS NO REASON LEFT FOR ANYONE TO BUY, OWN
OR OPERATE A GREYHOUND TRIVIA. ■ WE HAVE
CONVERSIONS FOR ANY DOG MACHINE, INCLUDING
GLASS, AT A PRICE YOU CAN'T PASS UP.



merit industries inc.

1-800-523-2760

Announcing!

\$50,000

PUB 

TIME

Darts™

1986 National Championship —

**—Beginning in your
soft tip location NOW!**

**Get started with your PUB
TIME Qualifiers Tournament
Kit—everything you need to
run 8 weekly qualifying
tournaments and location*
championship. Each location's
winners get a chance at the
state championship, then the
best shooters from men's A,
B & C and women's A & B
classifications move up to
the BIG MONEY
PLAYOFFS at the —**

**1986 PUB TIME Darts
\$50,000
National Championship!**

**Watch for details in
upcoming issues of
DART LIFE Magazine**

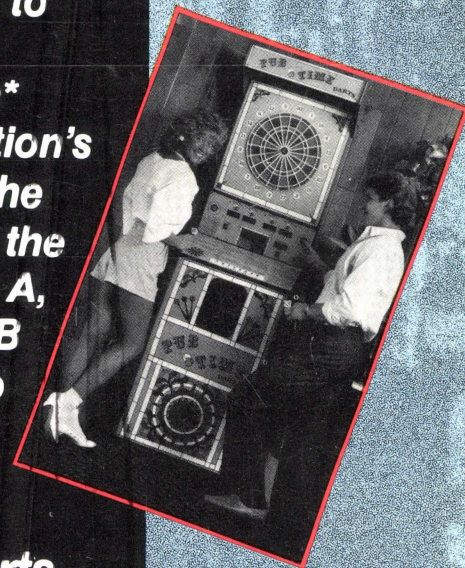
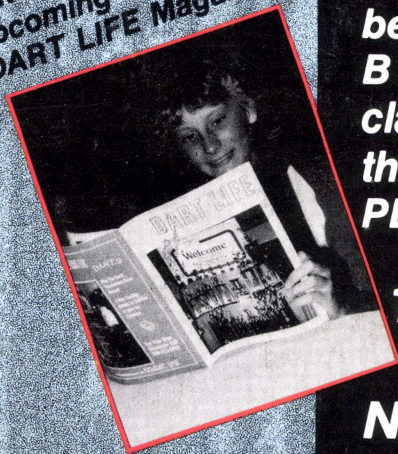

or write to:

**NOMAC LTD.
901 Armstrong
Algenquin, IL 60102**

**DART LIFE Magazine
10017 Bard Rd.
Huntley, IL 60142**

*All state and national championships will be
played on PUB TIME electronic dart machines.

Sponsored by

PUB TIME Darts • DART LIFE Magazine • NOMAC LTD.

For your nearest PUB TIME Distributor call 1-800-323-0449