

**No1  
FOR  
CBM 64!**

A NEWSFIELD PUBLICATION  
No. 55 NOVEMBER 1989

**£1.25**

US \$ 4.50

**WIN A  
SATELLITE  
SYSTEM  
FROM  
POWERPLAY!**

**WORLD  
EXCLUSIVE  
POWER  
DRIFT  
REVIEW**



**BATMAN:  
THE MOVIE**

**Reviewed on C64 and AMIGA!**

**THE UNTOUCHABLES**

**Beat the booze with Ocean!**

**TURBO OUT RUN**

**EXCLUSIVE preview!**



A  
**CRASH**  
Smash

**SINCLAIR**  
USER  
**CLASSIC**

C+VG  
HIT!

**GOLD MEDAL AWARD**

YOUR SINCLAIR  
**MEGAGAME**



**BATMAN** is a shadow in the darkness, as elusive as a dream. High above the seamy streets of GOTHAM, he is a criminal's nightmare. The only hope for a desperate city – BATMAN.



AMSTRAD  
**£9.99**  
COMMODORE

SPECTRUM  
**£9.99**  
SPECTRUM

ATARI ST  
**£19.99**  
ATARI ST

AMIGA  
**£24.99**  
AMIGA

TM

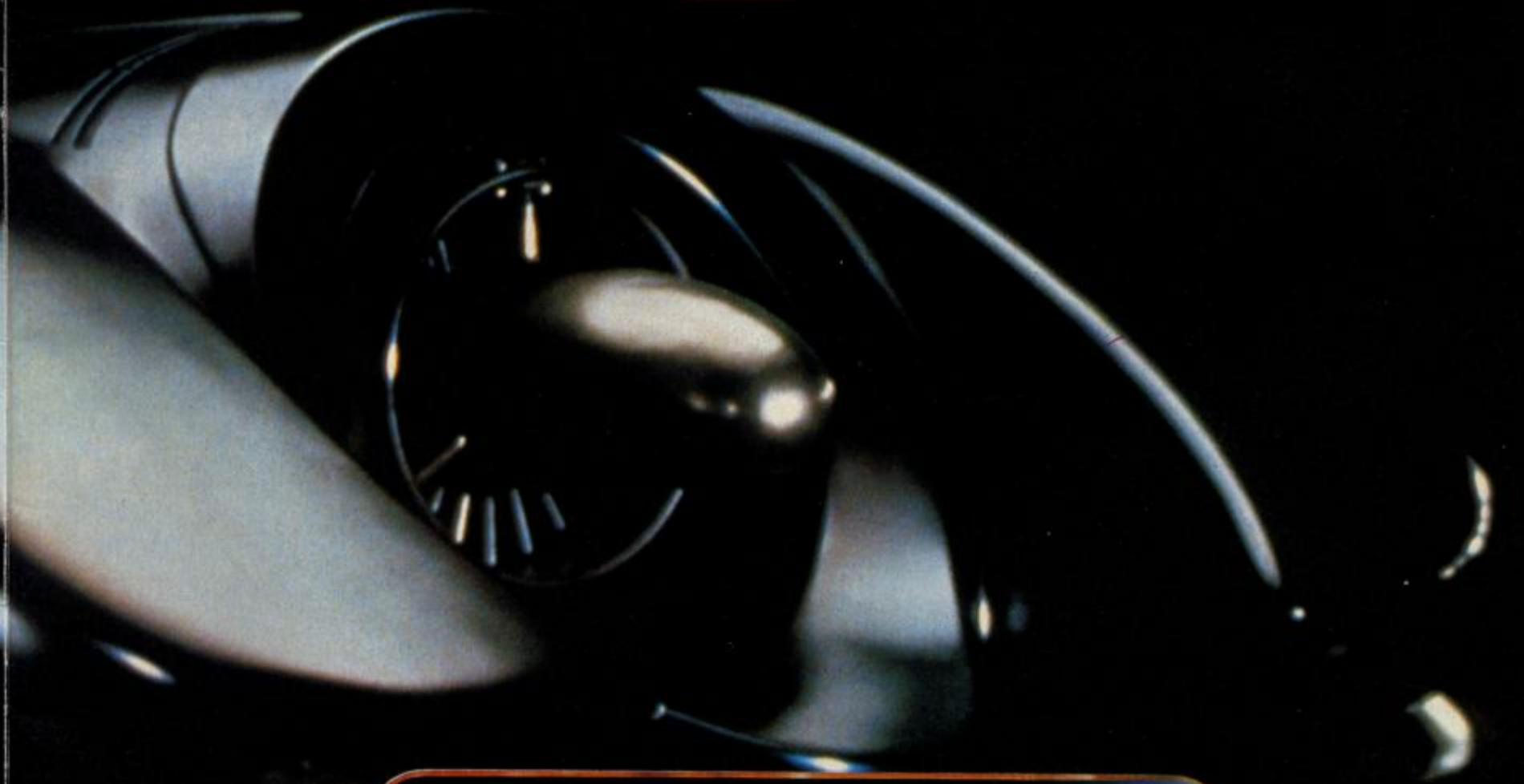

**ocean**

TM & © 1989 DC Comics Inc.  
All Rights Reserved.

Ocean Software Limited - 6 Central Street - Manchester - M2 5NS  
Telephone: 061 832 6633 - Telex: 669977 OCEANS G - Fax: 061 834 0650

IT BRINGS OUT THE BEAST IN YOU!

# DRAGON SPIRIT™



Scorch through the skies in the most challenging flight of your life. Breath fire over hordes of attacking creatures from a prehistoric age.

- A scorching, rip-roaring fight to the death
- Pick up bonuses for mega weapons and extra firepower
- 8 levels of pulse-racing action
- Exhilarating and challenging...
- Have you got the fighting spirit? Have you got Dragon Spirit?

Programmed by: Consult Software Ltd  
© 1989 TENGEN INC. All Rights Reserved  
TM and © 1987 NAMCO LTD

**TENGEN**

*The New Name in Coin-Op Conversions.*

**DOMARK**

Published by DOMARK LTD,  
FERRY HOUSE, 51-57 LACY ROAD, LONDON SW15 1PR Tel: 01-780 2224

AVAILABLE FOR: ATARI ST, AMIGA, COMMODORE 64 CASSETTE AND DISC,  
AMSTRAD CASSETTE & DISC, SPECTRUM +3, SPECTRUM 48/128.

# ZZAP!

## C64 AMIGA

ISSUE 55 NOVEMBER, 1989

# CONTENTS

## REVVING REGULARS

### 6 THE WORD

Amazing news about Level 9, plus another Ed Stu editorial – can you wait?!

### 20 NORMAN NUTZ

Dr Nutz puts his feet up and lets Ed Stu 'boldly go where no Ed has ever gone before!'

### 24 RESULTS

After his hols Ken D Fish comes back with a splash.

### 29 RRAP

The loonies have escaped from their padded cells and are all writing to 'perfectly sane' Lloyd.

### 40 SCORES

The alien hits the bleach the bottle again after some more reviewer torturing.

### 46 CLASSIFIEDS

For sale: Dr Norman Nutz (and Geek?).

### 49 COR BLIMEY!

Some great budget games, including ace rereleases *Wizball* and *Pitstop II*.

### 53 A PIG IN A POKE!

Robin 'Boyo' Hogg takes over the tips section and crams more tips into nine pages than has ever been attempted without a safety net!

### 64 ZZUPERSTORE

Even more bootiful bargains from the mysterious Dr Frey. How does he do it?

### 81 PREVIEWS

More games than you can shake a dafodil at, including the long-awaited *Operation Thunderbolt*.

## FAST FEATURES

### 34 PEDAL TO THE METAL!

An EXCLUSIVE preview of US Gold's super-sequel, *Turbo Out Run*

### 37 GIVE IT SOME STICK!

Phil King gets to grips with all the latest joysticks and breaks most of them!

### 42 A FREE POSTER

Another one for your wall: System 3's superb *Sizzler Tusker* is given the ZZAP! centrefold treatment!

## CLUTCH COMPS

### 27 WIN A SATELLITE DISH!

Generous joystick-makers, Powerplay, go Crystal crazy.

### 45 COMPUCOMP!

Your very last chance to win one of five more modems from Compunet.

## GEARSTICK GAMES

### 9 BATMAN

Holy Pickled Cabbage! The Caped Crusader collects a well deserved Gold Medal.

### 68 POWER DRIFT

Zooming into ZZAP! Towers, Chris Butler's racing game collects a Sizzler and speeds off again along Ludlow's dusty highway!

### 76 THE UNTOUCHABLES

Violent criminals, spectacular shoot-outs, police corruption – it's enough to drive anyone to drink!



## GAMES REVIEWED

BATMAN: THE MOVIE (GM)	9
BATMAN: THE MOVIE (Amiga)(GM)	12
BEACH VOLLEY (Amiga)	75
CONTINENTAL CIRCUS	17
CONTINENTAL CIRCUS (Amiga)	17
COSMIC PIRATE	49
CRYSTAL CASTLES	49
FIREPOWER	18
INDY: THE ACTION GAME	14
PITSTOP II (SM)	49
POWER DRIFT (S)	68
PRO TENNIS TOUR (Amiga)	74
RVF (Amiga)	70
STAR TREK: THE PROMETHEAN	
PROPHECY	20
3-D POOL (Amiga)	70
UNTOUCHABLES, THE (GM)	76
VIGILANTE	18
WIZBALL (SM)	68

EDITORIAL 47 Gravel Hill, Ludlow, Shropshire SY8 1QS ☎ 0584 5851/2/3 Editor: Stuart Wynne Sub-Editor: Phil King Staff Writers: Robin Hogg, Lloyd Mangram Editorial Assistants: Viv Vickress, Caroline Blake Photography: Cameron Pound, Michael Parkinson PRODUCTION 1/2 King Street, Ludlow, Shropshire SY8 1AQ ☎ 0584 5851/2/3 Production Manager: Jonathan Rignall Designer and Illustrator: Mark Kendrick Assistant Designer: 'International Treasure Hunter' Mel Fisher Reprographics/Film Planning: Matthew Uffindell, Robert Millichamp, Tim Morris, Jenny Reddard Editorial Director: Oliver Frey Group Advertisement Manager: Neil Dyson Advertisement Sales Executives: Sarah Chapman, Lee Watkins Assistant: Jackie Morris ☎ 0584 4603 0584 5852 MAIL ORDER Carol Kinsey SUBSCRIPTIONS PO Box 18, Ludlow, Shropshire, SY8 1DB Typeset by the Tortoise Shell Press, Ludlow. Colour origination by Scan Studios, Islington Green, London N1. Printed in England by Carlisle Web Offset, Newtown Trading Estate, Carlisle, Cumbria CA2 7NR – a member of the BPPC Group. Distribution by COMAG, Tavistock Road, West Drayton, Middlesex.

COMPETITION RULES The Editor's decision is final in all matters relating to adjudication and while we offer prizes in good faith, believing them to be available, if something untoward happens (like a game that has been offered as a prize being scrapped) we reserve the right to substitute prizes of comparable value. We'll do our very best to despatch prizes as soon as possible after the published closing date. Winners' names will appear in a later issue of ZZAP!. No correspondence can be entered into regarding the competitions (unless we've written to you stating that you have won a prize and it doesn't burn up, in which case drop Vivien Vickress or Caroline Blake a line at the PO Box 18 address). No person who has any relationship, no matter how remote, to anyone who works for either Newsfield or any of the companies offering prizes, may enter one of our competitions – and that includes fish.

No material may be reproduced in part or in whole without the written consent of the copyright-holders. We cannot undertake to return anything sent into ZZAP! – including written and photographic material, hardware or software – unless it is accompanied by a suitably stamped, addressed envelope. Unsolicited written or photographic material is welcome, and if used in the magazine is paid for at our current rates.

ABC

MEMBER OF THE ADVERTISERS' BUREAU OF CIRCULATION

ISSN 0954-867X

©ZZAP! 64 Ltd 1989

COVER DESIGN & ILLUSTRATION BY OLIVER FREY

NEWSFIELD  
A NEWSFIELD PUBLICATION

# The



# WORD

## A C64 Xmas?

Finally, the summer software drought seems over with high quality games flooding in for the C64. While the Amiga lacks a single Sizzler, the C64 wins TWO Gold Medals and one Sizzler. Hats off first to Ocean, for putting so much time and effort into their movie licences. The number of sub-games and levels offered by the two products is astonishing, as is the sheer polish which makes them so much fun. And applause too, for Chris Butler doing the impossible for Activision.

Clearly the C64 has plenty of life left in it yet. In terms of presentation, playability and the sheer amount of levels crammed into C64 games today's programs blow away all but a few classics from the old days. The technical excellence delivered by *Power Drift*, and promised by *Turbo OutRun*, is simply amazing. And who would swap the value-packed, multiload Ocean licences of 1989 for those of 1985? Particularly as the good games that were around then

can now be picked up for £2.99 on rerelease, or in mega-value compilations. As the 1990s approach, the C64 offers all this for a quarter of the price of an Amiga, with new releases costing half as much as Amiga software. If you want amazing graphics the Amiga certainly delivers (see *Batman* preview!), but for the moment C64 owners can remain content: their machine offers by far the best value for money, with a range and quality of software second-to-none.

And with so much happening on the C64/Amiga scene it's a pity Paul Rand has decided to leave Newsfield for a job with publishing giant EMAP. Best of luck to him, and Robin Hogg who's bravely stepped into his shoes with a 'Pig In The Poke' playing tips section.

Stuart Wynne

## NO STICKS PLEASE, WE'RE BRITISH!

Q: What do you call a joystick without a stick?

A: Broken!

Could be, but how about **Warp I**? Resembling an air freshener, this revolutionary 'stick' also has no buttons – so no problems with fire-finger blisters! Instead the Warp I has 'smooth, golden, electronic sensors' and is promised to be to joysticks what joysticks are to broomsticks – ever tried sweeping up with a joystick?!

Seriously though, UK distributors *Porteous Developments* promised us that the Warp I is very easy and comfortable to use and its firing sensor can fire over a thousand shots per minute. Unfortunately, they weren't able to send us a sample in time for this issue, so you'll have to wait until next month to find out if the £17.99 (RRP) stick really will 'boldly take you throughout the many worlds you will encounter in your present and future adventures.'

Meanwhile, *Spectravideo* are launching another joystick that isn't! Resembling a motorbike handlebar, the **Flight Controller** is designed to be grasped by both hands, using one thumb on the joypad and the other on the fire button. Of course (as seen in the piccy) to get the best out of the £12.50 'game controller' you'll need a pair of black leather gloves.



## LEVEL 9 QUIT ADVENTURE SCENE



Level 9, the successful adventure software house, have announced that their latest release, *Scapeghost* is to be their last ever adventure game. Managing Director, **Mike Austin**, commented, 'It just isn't worth us doing any more adventures.'

After continued success in the adventure field, with 15 top selling games since their 1981 inception, the now Southampton-based company are to concentrate on their revolutionary H.U.G.E. (wHolly Universal Games Engine) development system which will be used to create more arcade-orientated games for four 16-bit computers (Amiga, ST, IBM PC, and Apple Mac) with 'high graphical speed and utilising sophisticated data compression techniques to allow more game code to be held in memory/on disk'. The system took 10 man years to develop and includes a massive (30lbs when closely printed!) 165,000 lines of code.

A major (but as yet, unnamed) US publisher has already commissioned Level 9 to write a number of games using the system, and negotiations with other companies are also in progress. However, **Mike Austin** asserted that Level 9 would continue to work on some non-H.U.G.E. projects – presently, some work is being done on an RPG, although this is not yet certain to be released.

## DUCKULA À L'ALTERNATIVE

Count Duckula, the vegetarian vampire duck who appears in his own TV cartoon series is now to star in a computer game. Budget house, *Alternative Software*, have obtained the licence for TV's most popular duck – his shows are watched by an average of over 6 million viewers.

Alternative are no newcomers to children's TV licence, having had much success with the best-selling *Postman Pat* – the first ever budget licence. Indeed, they're already working on a 16-bit version of the manic mailman along with an 8-bit sequel.

## EGYPTIAN EYE

Logotron have gone all Egyptian. No, they haven't moved their headquarters inside the Great Pyramids, but their next release, *Eye Of Horus*, is based on a hawk-headed Ancient Egyptian god. In this arcade adventure you lay the part of Horus, metamorphosing between man-god and hawk in his quest to recover the seven pieces of his father's body! Programmers *Denton Designs'* previous work includes *Shadowfire*, *Frankie Goes To Hollywood*, *The Great Escape*, and *Where Time Stood Still*, so all bodes well for *Eye Of Horus*.

Purchasers of the game will also have a chance to see Egypt for real by entering the competition included in the packaging. First prize is a week for two in Cairo (this even includes the flight and hotel!), while five runners-up will get complete sets of the Ancient Egyptian Tarot—Logotron say that only their lack of skill in the Tarot prevents them from mailing the winners now!

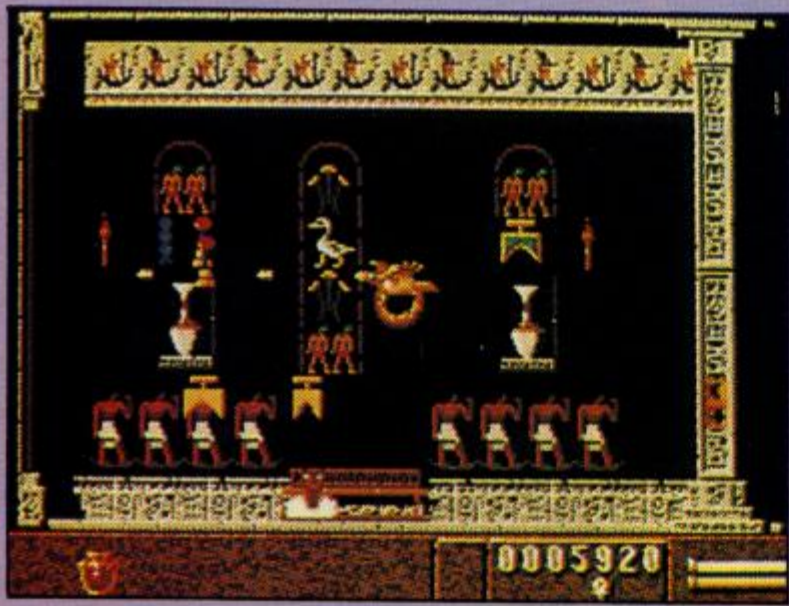

## VOLUPTUOUS VAMPIRES!



*Horrorsoft*, the adventure wing of Tynesoft, are set to release their second game, (following *Personal Nightmare*): *Elvira: Mistress Of The Dark* (The Dark's a lucky bloke!—Robin), based on that weird Queen Of Horror, *Elvira*.

What do you mean you've never heard of her? This 'cross between Gina Lollabrigida and Vampirella' rose to fame, hosting her own horror movie programme on American TV, and recently starred in her debut movie *Elvira: Mistress Of The Dark* (well, well, it's got the same name as the game!) which is soon to be released on video. She has even been praised by well-respected film critics—Film 89's *Barry Norman* said of her, '... Elvira is outstanding ... well two bits of her anyway.'

The first lady of horror is apparently so popular that you can buy *Elvira* records, greeting cards, posters, T-shirts, comics, models, calendars, and even make-up, wigs, and costumes (don't get excited now, Robin!).

Plans for another game, *Elvira: Mistress Of Robin*, have been scrapped due to a low credibility factor!



## KINGS OF COMEDY

Xmas is coming fast, and already the software houses are vying to produce the most extravagant press launch for journalists to get drunk at. The most impressive so far must be Hewson's medieval banquet at Warwick Castle, complete with knights in armour, serving wenches, jesters and just a Rambo-sized knife to eat your lamb chop with. Presiding over it all was *Andrew Hewson*, looking not unlike the king out of Disney's *Robin Hood* lost in an outsize royal robe and crown. Inevitably compelled to make a speech, Andrew came up with a creditable performance, improbably turning Gallup research into a comic routine:

Andrew—'And what sort of boxes do 9/10 retailers want?'

Audience—'We don't know, what sort of boxes ...'

There was even a spot of news about new releases, which include a weird range of 8-bit budget software converted to the Amiga (*Slayer*, *Battle Valley*, *Steel*) and some great compilations—for the Amiga, *Premiere Collection 2* (*Eliminator*, *Custodian*, *Mercenary*, and *Backlash*), while the C64 has the *Christmas Collection* (*Uridium*, *Lightforce*, *Cybernoid 2*, *Sanxion*, *Eliminator*, and *Exolon*). The former is £29.99, the latter £12.99 on cassette, £17.99 on disk.

The hottest release though, is undoubtedly the dazzling medieval arcade game *Onslaught* with four different arcade sub-games and 256 locations. There's even a built-in 'kingdom creator' which we hope Hewson use to create a C64 version!

But if Hewson had the most imaginative launch, Ocean remain top in the comedy stakes with Software Supremo Gary Bracey's round-up of their 'serious' 1990 line-up: 'First in our series of games based on Shakespeare's plays is *The Merchant of Venice*, obviously featuring Shakespeare's most famous character—Shylock Holmes. The game will be a maze game, with the characters chased by the famous pound of flesh.' Top that, MicroProse!

## THE HARLEQUIN RETURNS!

Yes, that weirdly garbed ex-ZZAP! adventure reviewer has returned! He's just one of four characters who have formed the new *Inter-Action* association for adventure, RPG and strategy players.

Along with Rob Steel (formerly of TGM), Auntie Marg (mad, alcoholic strategy person), and Nik Wild (the one with the money and the good looks (Are you sure about the latter?—Ed)), the Harlequin will be producing 6 bi-monthly A5 dossiers for association members. Each dossier will be at least 50 pages, crammed with in-depth reviews, features and lots of tips, maps etc for most home computers.

The annual membership fee of £15 also entitles members to regular newsletters and access to a telephone helpline, open from 5—7pm Monday to Friday.

For more information, write to: *INTER-ACTION*, The Cottage, Ashford Carbonell, Ludlow, Shropshire, SY8 4DB.



# CABAL



**The coin-op sensation** that throws you deep into enemy territory with little more than a low-powered, single shot repeater for protection. With superior marksmanship and lightning reactions you can increase the odds – in your favour.

Capture enhanced weaponry, including grenades, and now you can really make your mark! ... that is, until you come face to face with the enemy gunships, tanks and submarines. Equip yourself for some stunning arcade action, load up and **FIRE!!!**

## ocean

Ocean Software Limited  
6 Central Street - Manchester  
Telephone: 061 832 6633  
Telex: 669977 OCEANS G  
Fax: 061 834 0650

<b>SPECTRUM</b>	<b>£8.99</b>
<b>COMMODORE</b>	<b>£9.99</b>
<b>AMSTRAD</b>	<b>£9.99</b>
<b>ATARI ST</b>	<b>£19.99</b>
<b>AMIGA</b>	<b>£24.99</b>



# BATMAN

## THE MOVIE

Ocean, C64 £9.99 cassette, £14.99 disk

●Man-Bat attacks police! Gotham Globe Exclusive!

A giant bat-man was last night involved in a police shoot-out at the controversial Axis Chemical works. For some weeks the Gotham Globe has been carrying reports of a bat-like creature menacing Gotham City hoodlums at night. While scoffed at by other newspapers and the Gotham City Police force, it now seems undeniable that there is a bat-like vigilante at work. Many police officers involved in the raid said the creature was about eight feet tall, could fly and was invulnerable to bullets.

These dramatic developments began with a police raid on the Axis plant. A Lieutenant Eckhardt, shot during the raid, apparently had a tip-off that Jack Napier – the right hand man of Gotham crime boss Carl Grissom – was leading a bunch of crooks in a break-in at the works. Police and criminals were soon in pitched battle, with the police firing their pistols and the criminals throwing gas bombs.

From the moment Batman arrived on the scene he was clearly on the trail of Jack Napier, then hiding out on the far right hand side of the 60 screen, maze-like plant. To defend himself from police and criminals Batman hurled a seemingly endless supply of batarangs. He could also knock people out by swinging on a rope he could fire upwards to attach to catwalks. Although a single bullet did little harm, police speculated that the caped crusader could only take so many hits or falls. Swinging into a brick wall was also pre-



▲ Pursued by police the Batmobile races toward the secret Batcave.

With **Indy** knocking **RoboCop** off the top of the charts, this is Ocean's great black hope for getting back on top. While hype might make that virtually inevitable, the game actually deserves it. Though the chemical works/cathedral levels look a lot like **RoboCop**, the batrope idea means they play a lot different – a lot faster in particular. The Batwing and Batmobile levels are really good as well, making it a real pain when you lose all your lives and have to reload level one. Still, I suppose it could be a bit easy otherwise, and the way bonus points depend on how fast you complete the levels means you've always got an incentive to do better.

Holy Cow, Batman, it's a hit!





Test

sumed to be harmful, as were acid drop and gas from broken pipes. Police Commissioner Gordon was certain that within six minutes his men would certainly have arrested the vigilante.

As it was though, Batman caught up with Napier and knocked him into a vat of acid, apparently killing him . . .

Stop the press! The Batman has had another clash with police. In this latest incident Batman rescued press photographer Vicki Vale from the clutches of The Joker. The garishly garbed comedian of crime was vandalising the Fleugelheim Museum when Batman rescued Vale. He escaped in an immensely fast and strangely shaped vehicle already dubbed the 'Batmobile'.

The Batmobile rocketed across the horizontally scrolling Gotham City streets, weaving in between civilian and police cars. Turns down streets facing out of the screen were made by shoot-

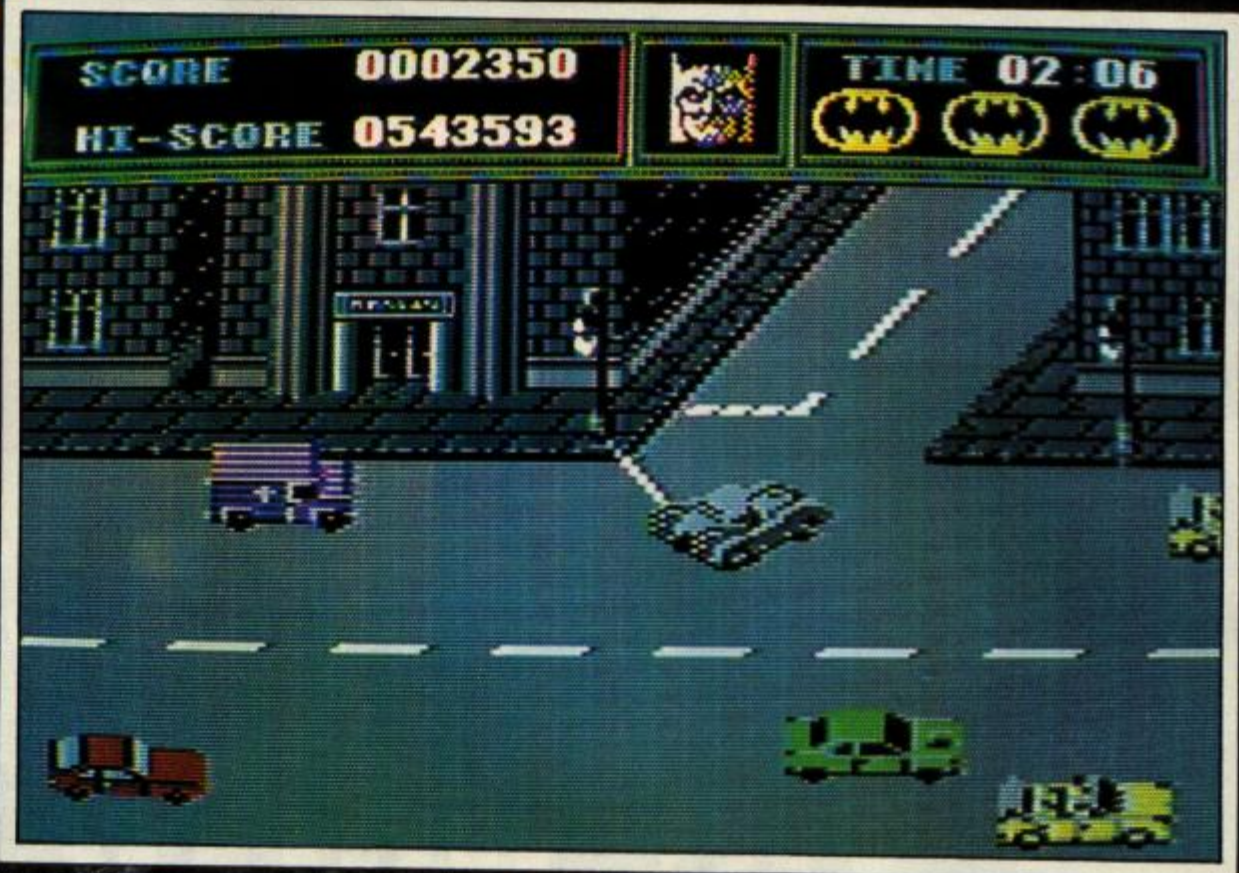

▲ The Batmobile eludes police using the batrope to make 90° turns.



The mysterious hooded vigilante swings into action at the Axis Chemical Works.

▼ A gas bomb explodes harmlessly near Batman's feet.



ing a cable to whip the car round at great speed. If a turning was missed the Batmobile had to turn around and go back, facing oncoming traffic and probably taking great damage. But if turns were ignored the Batmobile would've surely run into a police blockade. Once again Commissioner Gordon said his men were within seconds of apprehending the vigilante . . .



The movie was superb, a visually overwhelming spectacular with interesting characters and a good script. Now, thanks to Zach Townsend and Andrew Sleight, it's been turned into a game that's great to look at, and brilliant to play. The Batman sprite on the first and final levels is superb, it's really good how you can see his logo when he throws the batarang. More importantly he moves well too, swinging around with the batrope is so much fun you'll never want to walk! So even when you know your way round it's never boring. My favourite part is using the rope to swing and knock over enemies which could often best be dealt with by batarang.

The Batmobile section is excellent as well, though to begin with you can be too busy admiring the police cars to notice the yellow arrow telling you to turn! Back at the Batcave the puzzle works well, with the key being not to panic under pressure. Probably the toughest section though, is the Batwing one, with a superb Batwing sprite swooping around the Gotham streets in fine style.

Fans of the film can't miss this one, but even if you hated it there's no denying the quality of one of the year's best C64 games!



Was there ANY doubt at all that the game would fail? It's finally here and must rank as THE film tie-in for this year in quality, presentation and overall slickness. Batman is a dark sprite with a wonderful sheen effect on his costume. Along with the man himself is a small but nippy Batmobile and a stunning Batwing.

I was doubtful about the lasting appeal of the driving/flying scenes but they're a completely different style to the large location arcade adventuring of part one, and so require totally different tactics to get through. Even the last section is sufficiently different from the first to involve a new set of tactics, as it means climbing up rather than across. The swinging rope effect is what made the game for me, being able to control your ascent or descent is a brilliant touch.

A wonderful package of action and adventure, with an incredible atmosphere to match.



**Batman Saves Gotham!**

The riddle of the apparently random product poisoning afflicting the city has been solved by Batman. According to a report given to Vicki Vale it isn't that just one or two products have been contaminated, but that three whole ranges of products. These don't kill on their own, but only when combined. Batman found out which three by a 'Mastermind'-type chemical process. In a one minute time limit he put three products into analysis, the computer said how many were contaminated and Batman used a process of elimination to find out which one, then went on to find the other two.

Swooping low over Gotham the Batwing cuts free poison-filled balloons.

**Batwing Foils Joker's Plans!**

Last night's carnival, led by the Joker throwing out free dollar bills, almost turned to tragedy due to the enormous balloon floats being filled with Smilex poison gas. But before the gas could be released the Batwing flew down the horizontally scrolling street, its wingtips cutting the cables which were moving the balloons up and down. If the Batwing had hit too many balloons, or left them to explode, thousands might have died!

The Batman's flight was cut short however, by a lucky shot from the Joker. The Joker

quickly took refuge on the roof of the City Cathedral. This vast 100 screen building had the Batman rushing after Joker, in a confrontation much like that at the Axis Chemical works.

According to some reports a UK software house has been so impressed by Gotham's Dark Knight they plan a computer game, with the Axis plant as one load, the Batmobile, Batcave and Batwing another, and the Cathedral the third and final load. It will have to be some game to do the Caped Crusader justice!

▼ The Batman makes his way up the Cathedral, disposing of criminals along the way.



**amiga**

See previews now!

**update**

**PRESENTATION 94%**

Free logo sticker and nice plot info between levels.

**GRAPHICS 94%**

While the villains aren't that detailed on loads one/three, everything else is virtually perfect.

**SOUND 92%**

Different tunes for each level, option for okay FX. Pity Danny Elfman's score couldn't be used, though.

**HOOKABILITY 96%**

Easy to get into, and messing around with the batrope is brilliant.

**LASTABILITY 97%**

Five superb levels of gradually increasing toughness.

**OVERALL 96%**

The movie-of-the-year gets the game it deserves.

# BATMAN

Ocean, Amiga £24.99

**T**wo days after our deadline, Amiga Batman has swung into the ZZAP! offices and blown us all away. The first stage has a similar layout to the C64, but more acid drops, steam jets and criminals make it tougher. In addition the criminals fire faster and aim at you when you're under them – not nice!

The Batmobile section has you racing *into* the screen in full 3-D perspective with incredibly detailed buildings whizzing past at great speed. As on all the stages there's a choice of superb sound or brilliant FX. The drone of the Batmobile engine, and the



▲ Having a swinging time on level one.

**STU:** Up until now Ocean has failed to produce a massive, state-of-the-art 16-bit game. Now they have, and it's amazing. Racing along in the Batmobile with the sound turned way up is just so good, in fact presentation is overwhelming all the way through. Each section is so enjoyable to play that it's hard to pick favourites. This is one Amiga game that more than justifies its price. Awesome.

**PHIL:** I was expecting the detailed backgrounds and sprites, but what came as a surprise was the increased difficulty. Level one is a lot tougher, as is the totally brilliant 3-D Batmobile section – an astonishing game in itself! All five levels are extremely playable with plenty of gameplay variety, making this a true Amiga classic.



▲ The panic-inducing Batcave section.

▼ Your wings are on fire and there's just a minute and a half to cut free 63 balloons!



▲ Burning rubber on the approach to a turn with batrope extended.

thump as it comes down after bouncing over a hill is great. You race through traffic against a time limit, turning left or right where indicated. Miss a turning and you get two more chances before running into a roadblock.

The Batcave section is the same, only with less slots to put your guesses in. Then it's the Batwing section, again in full 3-D. Cut the balloons free to save Gotham before time runs out.

The final section is the Cathedral with appropriate graphics, new criminals and lots of rats!

**RH:** The fantastic thing about **Batman** is that it *really* is an Amiga game and not just a conversion. The first level is a better challenge, but the Batmobile section – well, words fail me – the 3-D effect has more speed and detail than I thought possible. The sound effects are good but it's the music that really got me excited – the Batmobile section has a stunning rock track and the Batcave a panic-inducing uptempo tune. Overall, unbelievable!

**PRESENTATION 94%**

Free sticker, great intro tune with 'who are you?' sample and no disk-swapping.

**GRAPHICS 97%**

The Batmobile and Batwing sections are out-of-this-world, and the other levels are superb too!

**SOUND 96%**

Sampled FX are great on their own, but you can turn on a different tune for each level as well.

**HOOKABILITY 95%**

Bit difficult to start with, but you soon get into the swing of things (groan!).

**LASTABILITY 97%**

Five incredible levels provide a substantial challenge, but even if you complete it you're going to keep playing this for a long time.

**OVERALL 97%**

Cor!

Virgin Games

# CONTINENTAL CIRCUS

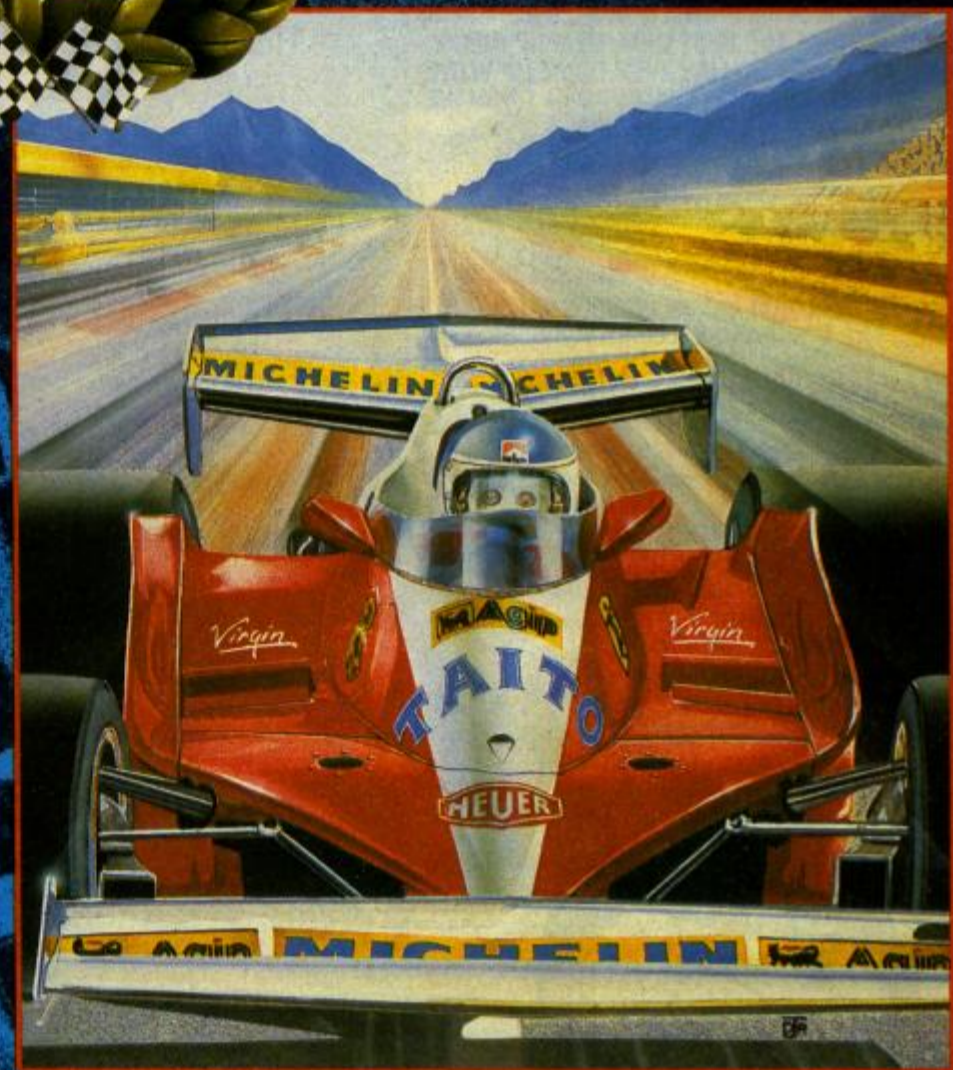

AMIGA



ATARI ST



CBM64/128



SPECTRUM



AMSTRAD

Prove to the racing world that you have the guts and determination to become a Formula One Driver. Take the challenge of the CONTINENTAL CIRCUS, consisting of eight races in eight different countries. **YOU MUST NOT FAIL!**

available on

- AMIGA £19.99
- ATARI ST £19.99
- C64 CASS £9.99
- C64 DISC £14.99
- SPECTRUM £9.99
- SPECTRUM +3 £14.99
- AMSTRAD CASS £9.99
- AMSTRAD DISC £14.99

Licensed from © Taito Corp., 1988, export outside Europe and Australasia prohibited.  
 © 1989 Virgin Mastertronic Ltd.  
 Produced by The Sales Curve for Virgin Mastertronic.  
 2-4 Vernon Yard, 119 Portobello Rd, London W11 2DX

# HARWOODS

POWER  
*Part*

## NEW AMIGA POWERPLAY PACKS

Yes, Gordon Harwood Computers have yet again improved the value of their legendary offers with the launch of the all new Powerplay packs which now include mega releases such as BATMAN THE MOVIE, NEW ZEALAND STORY etc. etc. And, when you look at the full list of over 20 extra items IT'S GOT TO BE THE BEST DEAL DEALIN' DIEGO, YOUR AMIGA AMIGO HAS EVER COME UP WITH! REMEMBER ALL OUR PACKS CONTAIN AMIGA'S WITH THE FOLLOWING STANDARD FEATURES...

- 512K RAM
- 1Mb Disk Drive
- 4096 Colours
- Multi-Tasking
- Built-in Speech Synthesis
- Mouse
- 2 Operation Manuals
- Workbench 1.3
- System Disks
- Kickstart 1.3
- All Connecting Cables

ALL OUR PRICES INCLUDE VAT AND STANDARD DELIVERY SERVICE



**GORDON HARWOOD  
YOUR FIRST CHOICE  
FOR ANYTHING AMIGA!**

## POWERPLAY PACK1

**THE COMPLETE AMIGA GAMES PACK RIGHT NOW!**  
The NEW AMIGA POWERPLAY PACK1 now comes with OVER TWENTY ITEMS ABSOLUTELY FREE! This adds up to MORE THAN £400 SAVING

- Amiga A500 Computer (See std. features list)
- BATMAN THE MOVIE
- NEW ZEALAND STORY
- F18 INTERCEPTOR
- Buggy Boy
- Ikari Warriors
- Barbarian
- Thundercats
- Terrorpods
- Art of Chess
- Wizball
- Mercenary Compendium
- Insanity Fight
- Amegas
- Deluxe Paint II - Mega Paint Package
- Microblaster Autofire
- Microswitched Joystick
- 10 - Blank 3.5" Disks
- Disk Library Case
- Mouse Mat
- Tailored Amiga Cover
- Tutorial Disk
- TV Modulator (PACK 1 ONLY)

**SEE WHAT WE MEAN  
ABOUT COMPLETE!**  
You won't need to buy anything else for ages!

**£399**

## POWERPLAY PACK2

MONITOR THIS FOR VALUE!

Pack2 contains the Super Powerplay Pack1 PLUS a stereo, high resolution, Philips CM 8833 Colour RGB/Video Monitor.

SEE THOSE GAMES, HEAR THOSE GAMES WITH ADDED CLARITY...

**ONLY... £599**

## POWERPLAY PACK3

**NEW AMIGA AND COLOUR PRINTER PACK**  
Take our Powerplay Pack2, and add Star's fantastic LC 10 COLOUR PRINTER, to give you the ultimate colour home entertainment computer system!!!

If you would prefer an alternative printer from within our range, simply deduct £209.95 and add the price of the printer you require. (Any printer can be chosen).

'SEE IT IN PRINT' FOR JUST... **£799**

## POWERPRO PACK4

**NEW POWERPRO PACK 4 CONSISTS OF...**

- Amiga A500 Computer.
- Philips CM 8833 Colour Monitor.
- Star LC 10 Colour Printer.
- 'The Works' Integrated Business Software Package.
- Ten 3.5" Blank Disks in a Library Case.
- Mouse Mat.  Dust Cover.

'WE MEAN BUSINESS' AT JUST... **£799**

**HARWOODS THE NAME YOU CAN TRUST**



24H

## CREDIT TERMS

Gordon Harwood Computers are licensed brokers and facilities to pay using our Budget Account Scheme are offered on most items. APR 35.2%. 12-36 month credit sale terms are available to most adults, simply phone or write and we will send written details along with an application form. (Applications are required in advance).

\* Credit terms, with or without a deposit, can be tailored to suit your needs.

## ORDERING MADE EASY - COMPARE OUR SERVICE

- ORDER BY PHONE**...Phone our 24Hr Hotline using your Access, Visa or Lombard Charge Card quoting number and expiry date.
- ORDER BY POST**...Make cheques, bankers building society drafts or postal orders payable to GORDON HARWOOD COMPUTERS (N.B. Personal or business cheques require 7 days clearance from date of receipt before despatch).
- PAY AT YOUR BANK**...If you wish to pay by Credit Giro Transfer at your own bank, phone for details.
- FREE POSTAL DELIVERY** goods in: UK Mainland (5-7 day delivery); **OR COURIER SERVICE**...Add £5 per major item for next working day delivery, UK Mainland. (Orders normally despatched on day of receipt of payment or cheque clearance).

After you've purchased from Harwoods we'll still be here to completely satisfy you should any problems arise.



**12 MONTH WARRANTY**...If goods prove to be faulty within 30 days of purchase they will be replaced with a NEW UNIT. For the remainder of the Guarantee Period, all warranty repairs will be made FREE OF CHARGE!  
**COLLECTION FACILITY**...Any faulty computer or monitor can be collected from your home FREE OF CHARGE within the guarantee period. (UK Mainland Only)  
**FULL TESTING PROCEDURE**...All computers are thoroughly tested prior to despatch, all items are supplied with mains plugs where reqd.

# ERPLAY

## folia

### MONITORS

#### PHILIPS CM 8833 STEREO

Full 14" Stereo High Resolution Colour Monitor, (higher spec. than the CBM 1084S now discontinued, replaced by the CBM 1084)

- Twin Speakers.
- High Contrast Tube.
- SCART Euro-connector fitted as standard.
- Green Screen Switch for enhanced text mode.
- RGB/Al, TTL, Composite Video and stereo audio inputs.
- Can also be used as a TV with tuner or VCR.
- Supplied with Tilting Stand.
- Compatible with most micros.
- FREE lead for computer of your choice.
- ONLY FROM HARWOODS... 12 Month replacement warranty for major faults.

ALL THIS FOR JUST... **£222**

#### COMMODORE 1084

Full 14" High Resolution Colour Monitor

- RGB/Al, TTL, composite video and audio inputs.
- Supplied with cables for A500, CGA PC, C16-64-128.
- Can also be used as a TV with tuner or VCR.

GREAT VALUE AT ONLY... **£209**

### GRAPHICS HARDWARE

#### DIGIVIEW GOLD

Digitises static images in FULL COLOUR and all resolutions supported (memory permitting). Creates IFF and HAM files. Uses B&W, or colour with B&W mode video cameras.

**£139.95**

#### DIGI DROID

Totally automated motorised film rotator for use with Digiview. Prevents camera movement between passes.

**£59.95**

#### VIDEO TO RGB SPLITTER

Takes standard video signal, separates red, green and blue. Enables standard video recorder or colour camera to digitise in colour with Digiview Gold (requires clear picture pauses with recorder).

**£109.95**

#### RENDALE GENLOCKS

8802 **£249.00** Semi Pro  
8806 **£749.00** Pro

#### SUPER PIC

Real Time Frame Grabber & Genlock. Real time instant colour frame-grabber from moving video. Capture superb digitised video images in a range of resolutions from standard composite video source such as your domestic video recorder or video camera in a 50th of a sec. Includes Genlock to overlay Amiga graphics onto moving video.

only... **£499.00**

#### MINIGEN GENLOCK

Entry level Genlock for mixing moving video picture with computer graphics. Ideal for titling, no monitor required.

**MOVIE MAGIC... £113.85**

#### HITACHI VIDEO CAMERA

Mono, 650 scan lines

**£249.95**

#### ILLUMINATED COPY STAND

4 Light, adjustable, shake free stand for video camera. **£89.95**

### PRINTERS

All printers in our range are dot matrix and include the following features... Standard centronics parallel port for direct connection to Amiga, PC's, ST, etc. and come with FREE connector cables.

**CITIZEN 120D FULL 2 YEAR WARRANTY**  
Very reliable low cost printer, interchangeable interfaces available for Centronics RS 232 or Serial type for CBM 64 etc **£149.95**

**STAR LC10 MKII**  
Brand new superfast MK II version of this ever popular printer **£184.95**

- Multiple font options from front panel.
- Excellent paper handling
- Simultaneous, continuous and single sheet stationery.

**STAR LC10 COLOUR**  
Colour version of the LC 10 **£209.95**

- Allows full colour dumps from Amiga.
- Superb text quality.
- Can use black LC 10 ribbons.
- Our most popular colour printer!

**STAR LC 24 1D**  
24 Pin version of the Star LC series with exceptional letter print quality **£249.95**

All our Star printers are genuine UK spec. which are specifically manufactured for sale in the UK ONLY. Please be aware that European spec. versions are being unofficially imported against the wishes of Star Micronics UK. These printers DO NOT carry a Star UK warranty, and WILL NOT be serviced by them should the need arise. UK specification printers may be recognised by their 3-pin UK type plug which is MOULDED to the mains cable.

### ACCESSORIES

#### COMMODORE

**A 501 RAM PACK** New Low Price... **£119.95**  
Genuine CBM ram pack with real time battery backed clock... This add on DOES NOT invalidate Commodore's warranty.  
**A 500 POWER SUPPLY** **£49.95**  
Genuine CBM power supply, also fits CBM 128  
**A 520 TV MODULATOR** **£19.95**  
Supplied with all the necessary cables.

#### QUALITY ACCESSORIES

**REPLACEMENT MOUSE**  
Microswitched mouse buttons, high resolution mechanism. **Great Feet only... £29.95**

**FLOPPY DISKETTES**  
Genuine Commodore Disks  
Ten 3.5" **Commodore quality at only... £14.95**  
Quality certified 3.5" bulk disks supplied with labels  
10, with a library case **£9.49**  
10, uncased **£8.49**  
100, uncased **£69.00**  
100, with lockable storage case **£74.95**

**MICROBLASTER JOYSTICK** **£12.95**  
Fully microswitched, arcade quality

**ZIPSTICK SUPERPRO** **£15.95**  
Professional quality, perfect feel

### STORAGE DEVICES

#### HARD DRIVES

**COMMODORE A590 20Mb HARD DISK FOR AMIGA A500's**

Commodore's own Hard Drive for the A500  
 □ Autoboot with Kickstart 1.3  
 □ Sockets for upto 2Mb RAM expansion.  
 □ Can be expanded in 512K blocks.  
 □ DMA Access.  
 □ External SCSI port  
**Super Low Price... £379** (Call for Kickstart 1.3 upgrade prices)

**A590 HARD DISK 512K UPGRADE**

□ Onboard, fit up to 4, in stages, giving 2 Mb Total.  
 □ Up to 3Mb when fitted with A501 **only £69.95**

**30 & 50Mb AMDRIVE HARD DISK FOR THE A500**

□ 41ms Fast access drive.  
 □ True SCSI upto 500 kb/sec on standard A500.  
 □ Built in power supply.  
 □ 12 month replacement warranty included.  
 □ 2 Year warranty available.

**30 Mb Version... Only £399**

**50 Mb Version... Only £475**

**40 Mb VORTEX HARD DRIVE FOR BOTH AMIGA A500 AND A1000**

□ For both A500 and A1000 as supplied.  
 □ Autoboots on any Amiga.  
 □ Throughport and connector for 2nd hard drive.

**Great value at only... £499**

### FLOPPY DRIVES

#### CUMANA DISK DRIVES

The drives below have the following features:

- Enable/disable switch.
- Throughport.
- LED Access Light, super quiet.
- Suitable for A500, A1000, A2000 and CBM PC1.

**NEW CAX 354 3.5" SECOND DRIVE**

□ 25mm Super slimline 3.5" drive.

**A real bargain at only... £89.95**

**CAX 1000S 5.25" SECOND DRIVE**

□ Amiga DOS and MS DOS compatible.

**Save more than ever... £129.95**

### AMIGA SOFTWARE

**THE WORKS** **£79.95**  
Integrated word processor with spelling checker, spreadsheet with graphics and database.

**X-CAD DESIGNER** **£95.95**  
Perfect choice in Computer Aided Design (1Mb required).

**PUBLISHERS CHOICE** **£89.95**  
Complete solution for D.T.P. needs, contains Kind Words V2 W.P. package, Pagesetter V1.2 with Artists Choice clip-art and Headliner font pack.

**MUSIC-X** **£199.95**  
The most powerful music/midi/sequencing package available, features up to 250 tracks.

**FANTA VISION** **£39.95**  
Popular animation and sound package.

**DOS TO DOS** **£49.95**  
Transfer any PC MS-DOS or ST GEM file to your Amiga

4 HR ORDER LINE-0773 836781



### VISIT OUR SHOWROOM

Please call to see us where our full range of advertised products AND MORE is on sale. Come and see for yourself the amazing Amiga and a whole host of peripherals, software and accessories.

REMEMBER WE ARE NOT JUST ANOTHER MAIL ORDER COMPANY

All listed prices are what YOU PAY, and there are NO HIDDEN EXTRAS. VAT and Postage are included and prices are correct at time of going to press. E. & O. E.

Offers subject to availability and are currently advertised prices.

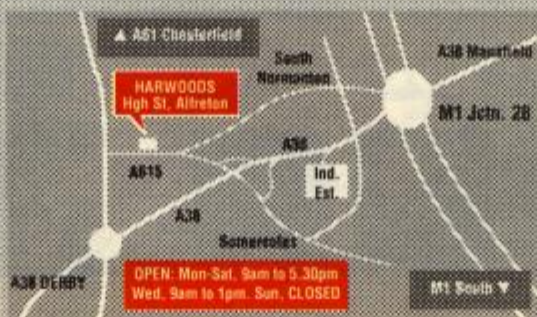

# GORDON HARWOOD HARWOOD HARWOOD Computers

**GORDON HARWOOD COMPUTERS**  
DEPTZAP-B1, 69-71 HIGH STREET  
ALFRETON, DERBYSHIRE, DE5 7DP.  
Tel: 0773 836781 Fax: 0773 831040

# INDY™ THE ACTION GAME

US Gold, C64 £9.99 cassette, £14.99 disk



**D**id you know the word grail comes from the word 'gradual', meaning step by step? No? Well, neither does the Collins English dictionary which claims the word derives from the Old French word 'graal'. Oh well, you shouldn't believe everything you read in instruction leaflets.



The similarity between the first four levels remains strong, but with a touch of extra speed playability is improved. And for only £10 the lack of variety isn't so much of a problem. Moreover on the C64 you don't expect the character to be 'blitted' about at great speed, and so the whole pace of the game is much more acceptable. Essentially an 8-bit game design, **Indy** seems at home on the C64 with attractive, weather-beaten sprites and backgrounds creating a good atmosphere. It's a pity then, that on levels like the Zeppelin there aren't more baddies to fight, but overall this is a professionally produced game which fans should enjoy.

The structure of the C64 game is much the same as the Amiga one, and starts with the youthful Indy (here represented by the designer stubble adult due to memory restrictions!) stumbling over the looting of a valuable archaeological site. The crooks are after the fabulous Cross of Coronado, here hidden somewhere in some maze-like caverns. Indy must avoid falling stalactites, jump from rope to rope over deadly water and whip

the baddies into shape. As it's dark underground Indy must use a torch to see by, but these burn out quickly so new ones have to be collected regularly. Once the Cross has been grabbed Indy has to escape from the caverns.

Succeed and the second half of level one is multiloaded in. Indy's escape sees him running along the top of a speeding circus train, complete with rhinos and giraffes sticking their heads out of their carriages.

Level two is the Catacombs, this is where the adult Indy is looking for a shield under a Venetian museum. This is a fairly big maze where rats and flames prove the main hazard, along with occasional lashes of lightning! Find the shield and Indy must scale the walls of Castle Brunwald, where Nazis are holding his father hostage. To get to the top he must wrap the whip around posts, automatically

▼ Don't climb down too far or you'll fall off into the water.



▼ Aboard a Zeppelin and looking for a way off.



swinging him between the shattered windows.

The next load transports Indy into the bowels of a huge Zeppelin airship which he'd hoped would take him out of Germany. Now it's turning back to Berlin, so Indy must get to the small planes suspended under the massive aircraft. Of course there are plenty of Nazi stormtroopers searching for him, so it's a good idea to find Nazi passports to stop the alarms going off. Before escaping Indy must find the Grail Diary which his father has lost.

The last level takes place in the temple of the Grail. Dr Jones Snr has been shot, and if Indy doesn't get the Grail to him he'll die. Of course the Grail is well protected, with razor-sharp blades to jump over, bottomless pits and tiles that crumble beneath the feet. This is a relatively short Metrocross-style level, but the time limit is harsh. On all the other levels, if you lose all your lives you can continue play on that level. But die on the final level and you go back to the Zeppelin level.



On the C64, at least, Indy gets a really quite good game. The main sprite is well drawn and animated, complete with stubble on his chin. Background graphics are generally good, with the Zeppelin stage nicely replicating the air sickness-inducing swaying of the Amiga version. Sound is a disappointment - spot FX only - but there's a good title tune. Actual playability is improved by being that vital bit faster, and with five loads this is a good value for money package.

### PRESENTATION 76%

Nicely done security codes, attractive packaging and good multiload.

### GRAPHICS 80%

Great, stubble-jawed Indy and good backgrounds. Pity about the Spectrum status panel.

### SOUND 48%

Respectable title tune, but in-game spot FX are a dull accompaniment to the action.

### HOOKABILITY 72%

Good, varied opening level makes the game easy to get into.

### LASTABILITY 73%

The levels aren't that different, but good playability keeps you coming back.

## OVERALL 72%

An attractive and playable game.





▲ Ooh, aah, ooh, aah, not too long to go now! (Amiga)



This was great fun in the arcades especially with the stereoscopic 3-D which heightened the excitement. Even though this is obviously missing from the home versions they retain the coin-op's fast, addictive action.

Technically, both versions are fast enough but lack any graphical frills – I was especially disappointed by the feeble smoke and explosion effects. The driving itself isn't that realistic, especially cornering where there's no need to slow down unless it's a really tight bend – on tortuous circuits like Monaco you can even take short cuts across the grass! But it's the pace and simplicity of the action that draws you in and keeps you playing.

Unfortunately I found it just that bit too easy to complete the first few tracks and it doesn't get that much harder on the later levels.

## CONTINENTAL CIRCUS

Virgin, C64 £9.99 cassette, £14.99 disk; Amiga £19.99

If you've visited the arcades within the last year you'll probably have seen and played one of the hottest driving games around: Taito's Continental Circus. The main innovation for the arcade machine was the stereoscopic 3-D used – the screen is viewed through a pair of special LCD glasses.

No such gimmicks for the home version but otherwise the game's the same. In your super-fast Formula One-type car you must race around the track, reaching the checkpoints within the time limit.

Of course, you're not the only car on the track – contact with computer cars or signs at the side of the track causes your engine to smoke – if you don't get to the pits in time, the car will catch fire and blow up. If you're smoking (very bad for your health) and suffer a second collision, the car spins out of control, exploding into a welter of fireballs. Miraculously, this does not cause your death but slows you down as you have to start accelerating again from a standstill.

Starting in Brazil, you race around eight tracks all over the world, finishing up in Japan. On later tracks an added hazard are the occasional rainstorms which makes the track slippery. To qualify for these later circuits you must complete the lap



Converting yet another racing game whose only unique feature, the 3D, would be lost might seem a silly idea. But while the finished game is completely unoriginal, it's been programmed well enough to be both attractive and fun to play. The 'extend' part of the game works well, providing a welcome diversion on fairly long tracks which don't change that much. Amiga owners benefit from a slightly faster game, but the C64 version is still very fast and much better value for money. All in all, two extremely competent and enjoyable conversions.

within the time limit and overtake enough computer cars to achieve the required rank. Fail to do this and you lose one of four credits.

▼ 95th position, just 52 seconds left, who'd you think you are? James Hunt? (C64)

So put your foot on the accelerator and your hand on the gearstick to be first to reach the gorgeous redhead waving the chequered flag!



64

**PRESENTATION 81%**

No multiloop. Good circuit diagram showing progress after race.

**GRAPHICS 74%**

Okay car sprites; nice side graphics and hills.

**SOUND 76%**

Fine engine drone, good 'Extend' and level-end tunelets.

**HOOKABILITY 81%**

Instantly playable...

**LASTABILITY 70%**

...but not much variety.

**OVERALL 74%**

An extremely playable coin-op conversion.

amiga

**PRESENTATION 70%**

Some attractive, digitized pictures between games.

**GRAPHICS 78%**

Fast 3-D scrolling and fine car sprites.

**SOUND 68%**

Dull engine drone and okay tunes.

**HOOKABILITY 80%**

Typical coin-op simplicity-makes it easy to get into...

**LASTABILITY 68%**

...but changing courses and background graphics don't add enough variety.

**OVERALL 73%**

Simple, addictive Formula One fun.

# VIGILANTE

US Gold, C64 £9.99 cassette, £14.99 disk



It's 1994 and Madonna has been kidnapped! It's up to you to rescue the sultry pop star from a vicious street gang. The first level is set in the



OBiN

The original Irem coin-op didn't have that much to distinguish it from other beat-'em-ups, but what there was has pretty much been lost here. There's no variety in the villains, and the skyscraper level where you had to jump between girders has been changed to be just like the rest. Lacking the high quality, gritty graphics of the coin-op this is just very average.

streets with our hero taking on villains ranging from wimpy guys to chain-wielding brutes. Up to two punks can attack at one time, and if they get too close one will put a lethal headlock on you. There's a chain you can pick up although it only lasts for a while, and at the end of the level there's an extra large guy to beat.



TU

It's been months since the Amiga game, so you'd hope it was well spent making the C64 one even better. Sadly, this isn't the case. The backgrounds are all fairly well drawn, and the sprites aren't bad either, but gameplay is repetitive. Once you've mastered the baddies on level one the only bit of variety is the handful of bikes on level three, and the extremely tough end-of-level baddies which only change graphically. Disappointing.



▲ Knock out the wimpy black-suited guys first to avoid being caught in a headlock.

The five multiloaded levels are all much the same except for level three where a few motorbikers try to run you over. Otherwise the only changes are the backgrounds and end-of-level baddies.

**PRESENTATION 55%**  
No intermission screens and when you die you have to reload level one.

**GRAPHICS 63%**  
Okay backgrounds, but the villains are all the same.

**SOUND 42%**  
Irritating in-game tune.

**HOOKABILITY 67%**  
Simple beat-'em-up fun starts off well...

**LASTABILITY 50%**  
...but there isn't enough variety.

**OVERALL 54%**  
A run-of-the-mill beat-'em-up.

# TIRE POWER



Microillusions, C64 £9.95 £14.95

An enemy helicopter buzzes by as you enter the war zone in the tank of your choice.

Suddenly bullets ricochet off the side of the tank. Tucked up inside, you're safe for now, but

when the armour wears thin you're dead. With a deft three-point turn you aim and fire at the copter, destroying it with a single shot.

Now to explore the large scrolling play area in search of

▼ Split-screen, two-player mode, with plenty of mines to be laid.

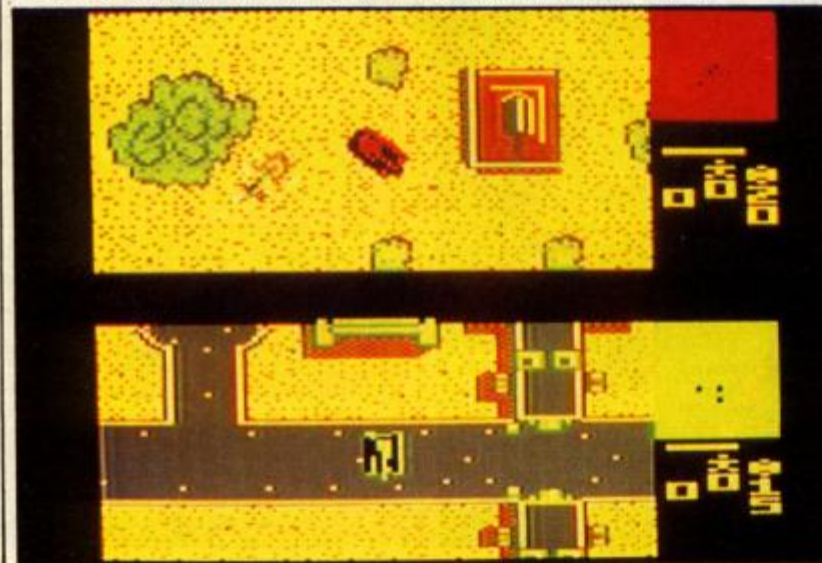

STU

I remember playing this on the Amiga, about a year back, and the C64 replicates gameplay precisely. Initially it seems quite good, hunting down another player's tank, and squishing soldiers under your tracks! The ability to lay lots of mines soon proves a problem however, it's too easy to run over them before you see them. In any case slowly rumbling through enemy territory, blowing up base after base, is extremely repetitive.

the enemy flag which will win you the game, when brought back to your base.

You have five lives, but there are plenty of gun turrets and helicopters to remove them. Giving your own injured soldiers a lift back to a hospital restores one life for every fifteen

rescued. Hate the ruthless computer enemy? Then play against a 'friend' on a split-screen display.



HI

Yuk! This simple tank game is terribly presented with undetailed sprites and hardly any sound. One-player games are especially dull just trundling around the monotonous play area searching endlessly for a flag. Two-player games are fun for a while but tend to be so long-winded (lives are infinite) that both opponents get fed up well before the game is won.

**PRESENTATION 31%**  
In-game instructions.

**GRAPHICS 35%**  
Dull and uninspired.

**SOUND 34%**  
Basic drone and a few explosion, soldier squishing FX.

**HOOKABILITY 43%**  
Two-player games are always fun to start with.

**LASTABILITY 32%**  
Lots of bases arranged in heavily defended mazes mean a tough, but repetitive challenge.

**OVERALL 36%**  
A severe lack of variety spoils a good idea.

# S.D.C 60 Boston Road, London, W7 3TR

Other branches – 309 Goldhawk Road, London, W12 8EZ

18 Market Square, Leighton Buzzard, Beds

\* Unit 33/34, Romford Shopping Hall, Market Street, Romford, Essex

\* 675 Holloway Road, Archway, London N19

(OPEN 7 DAYS 10 am – 8 pm)

**BUY BY PHONE**  
01 741 1222  
01 995 3652  
0525 371884

### PRICE PROMISE

If you wish to purchase any product from our list and find that you can buy the same product cheaper from another mail order company, simply enclose the lower amount, stating the name of the other company and where you saw the advert. (It must be the current issue). Price Promise does not apply to other companies' Special Offers.

**ENQUIRIES**  
01 567 7621  
OPEN 10-6 5 DAYS

C64	RRP	OUR PRICE
ACTION FIGHTER	9.99	6.99
AFTERBURNER	9.99	7.50
APB	9.99	6.99
BARBARIAN II	9.99	6.99
BATMAN	9.99	5.99
BEACH VOLLEY	9.99	6.50
BLOODWYCH	9.99	6.99
CARRIER COMMAND	14.99	10.99
DOUBLE DRAGON	9.99	6.99
DRAGON NINJA	9.99	6.50
DRAGON SPIRIT	9.99	6.99
EMLYN HUGHES INTERNATIONAL SOCCER	9.99	6.99
FOOTBALL DIRECTOR	9.99	6.99
FOOTBALL MANAGER II	9.99	6.99
FOOTBALL MANAGER II EXPANSION KIT	7.99	5.99
FORGOTTEN WORLDS	9.99	7.50
GREEN PEACE	9.99	6.99
GUNSHIP	14.99	10.99
HOSTAGES	9.99	6.99
INDIANA JONES & LAST CRUSADE	9.99	7.50
JOURNEY TO THE CENTRE OF THE EARTH	9.99	7.50
KENNY DALGLIESH SOCCER MANAGER	9.95	6.99
KICK OFF	9.99	6.99
LAST NINJA II	12.99	6.99
LICENSE TO KILL	9.99	6.99
MAZE MANIA	9.99	6.99
MICROPROSE SOCCER	14.99	10.99
NAVY MOVES	9.99	7.50
NEW ZEALAND STORY	9.99	6.99
OPERATION WOLF	9.99	6.50
PACMANIA	9.99	6.99
PRO SOCCER SIMULATOR	9.95	6.99
RALLY CROSS	9.99	6.99
REAL GHOSTBUSTERS	9.99	7.50
RED HEAT	9.99	6.50
RENEGADE II	9.99	6.50
RICK DANGEROUS	9.99	6.99
ROBO COP	9.99	6.50
RUN THE GAUNTLET	9.99	6.99
RUNNING MAN	9.95	6.99
SHINOBI	9.99	6.99
SKATEBALL	9.99	7.50
SPEEDBALL	9.99	6.99
STAR TREK	9.99	6.99
STORMLORD	9.99	6.99
TIME SCANNER	9.99	7.50
TRACKSUIT MANAGER	9.95	6.99
VIGILANTE	9.99	7.50
VINDICATORS	9.99	6.99
WAR IN MIDDLE EARTH	9.99	6.99
WEC LE MANS	9.99	6.50
WEIRD DREAMS	14.99	10.99
XENON	9.99	6.99
XYBOTS	9.99	6.99

### SPECIAL OFFERS

1943	9.99	6.50
ARENA	7.99	0.50
ARKANOID II	8.99	4.99
CAPTAIN BLOOD	9.99	2.99
CAULDRON	8.99	1.99
CAULDRON II	8.99	1.99
DAREDEVIL DENNIS	7.99	0.75
DOUBLE TAKE	8.99	1.99
EMPIRE STRIKES BACK	9.99	3.99
FIREFLY	8.99	3.99
FOOTBALL DIRECTOR	8.95	1.99
FOUR SOCCER SIMULATOR	9.99	4.99
IMOTEP HEAD CLEANER	9.99	0.70
KENSINGTON	9.99	0.99
L.C.P.	9.99	0.70
LAUREL & HARDY	8.55	0.75
LORDS OF MIDNIGHT	9.99	0.99
MATCHDAY II	9.99	4.99
RECORDS FILE (FOOTBALL DIRECTOR)	7.99	1.99
RETURN OF THE JEDI	9.99	4.99
SACRED ARMON OF ANTIPIAD	8.99	1.99
SPITTING IMAGES	9.99	2.99
SPLIT PERSONALITIES	8.99	1.99
STAR WARS	8.99	3.99
STIFFLIP & CO	8.99	1.99
TIGER ROAD	8.99	4.99
VIEW TO A KILL	2.99	2.99
VINDICATOR	8.99	3.99

### C64

**SOCCER SIMULATION**  
Only £8.99  
WORLD CHAMPIONS +  
FOOTBALL MANAGER +  
P. SHILTONS HANDBALL +  
MARADONA + SOCCER  
SUPREMO + P. BEARDSLEYS  
INT SOCCER

**COMPUTER CLASSICS**  
Only £3.99  
ZYNAPS + DYNAMITE DAN  
ALIENS (US) + CAULDRON +  
INTO EAGLES NEST

**FIVE STAR III**  
Only £4.99  
TRAPDOOR + URIDIUM +  
TAU CETI + FIRELORD +  
S F HARRIER + ALIENS (US) +  
WAY OF EXPLODING FIST

**BEST OF ELITE 1**  
Only £4.99  
BOMB JACK + AIRWOLF +  
FRANK BRUNO'S BOXING +  
COMMANDO

**LIVE AMMO**  
Only £6.50  
GREAT ESCAPE + TOP GUN +  
GREEN BERET + RAMBO +  
ARMY MOVES

**SUPREME CHALLENGE**  
Only £7.99  
ELITE + STARGLIDER +  
SENTINEL + ACE II + TETRIS

**SPECIAL ACTION**  
Only £8.99  
CAPTAIN BLOOD + SDI +  
DALEY'S OLYMPIC  
CHALLENGE + DRILLER +  
VINDICATORS

### AMIGA

**PRECIOUS METAL**  
Only £13.99  
CAPTAIN BLOOD + XENON +  
CRAZY CARS + ARKANOID II

**HIT DISK II**  
Only £15.99  
TIME BANDIT +  
MAJOR MOTION +  
LEATHER NECK +  
TANGLEWOOD

**COMPUTER HITS TWO**  
Only £9.99  
TETRIS + JOE BLADE +  
GARDEN PATH +  
BLACK SHADOW

**MEGA PACK 1**  
Only £16.99  
CAPTAIN BLOOD +  
BLACKLASH +  
PURPLE SATURN DAYS +  
SPIDERTRONIC

**EXCLUSIVE COLLECTION**  
Only £14.95  
Eliminator + Zynaps +  
Wanted + Action Services

**PREMIER COLLECTION**  
Only £18.99  
Exolon + Zynaps +  
Netherworld + Nebulus

### AMIGA

	RRP	PRICE
APB	19.99	12.99
ARCHIPELAGOS	24.99	15.99
BALANCE OF POWER 1990	24.99	15.99
BARBARIAN II	24.99	15.99
BATMAN	24.99	15.99
BATMAN THE MOVIE	24.99	14.99
BATTLETECH	24.99	15.99
BLACK CAULDRON	24.99	17.99
BLOOD MONEY	29.99	19.99
CASTLE WARRIOR	19.99	12.99
CHARIOTS OF WRATH	24.99	15.99
DOMINATOR	19.99	14.99
DRAGON NINJA	24.99	15.99
DUEL (TEST DRIVE II)	24.99	17.99
F16 COMBAT PILOT	24.99	15.99
F.O.F.T	29.99	21.99
GEMINI WING	19.99	12.99
GRAND MONSTER SLAM	19.99	14.99
GUERRILLA WARS	24.99	15.99
HAWKEYE	19.99	12.99
KICK OFF	19.99	12.99
KULT	24.99	17.99
LAST DUEL	14.99	11.99
LAST NINJA II	24.99	17.99
LICENCE TO KILL	19.99	12.99
MILLENNIUM	24.99	17.99
NAVY MOVES	24.99	17.99
NEW ZEALAND STORY	24.99	15.99
PAPERBOY	19.99	12.99
PHOBIA	24.99	15.99
PIRATES	24.99	15.99
RALLY CROSS	19.99	12.99
RAINBOW ISLAND	24.99	15.99
R.V.F. HONDA	29.99	21.99
RED HEAT	24.99	15.99
RICK DANGEROUS	24.99	15.99
ROBOCOP	24.99	15.99
RUN THE GAUNTLET	24.99	15.99
SHINOBI	19.99	12.99
SKWEEK	19.99	12.99
SLEEPING DOGS LIE	24.99	15.99
SPACE QUEST III	24.99	17.99
SUPER SCRAMBLE SIMULATOR	24.99	17.99
TARGHAN	24.99	15.99
THUNDERBIRDS	24.99	15.99
TIME SCANNER	24.99	17.99
TOTAL ECLIPSE	24.99	15.99
VOYAGER	24.99	15.99
WEIRD DREAMS	24.99	15.99
WICKED	24.99	17.99
XENON II - MEGABLAST	24.99	15.99
XYBOTS	19.99	12.99

### SPECIAL OFFERS

ACTION SERVICE	19.99	5.99
ALTERNATIVE REALITY	24.99	6.99
BACKLASH	19.99	4.99
BILLIARDS SIMULATION	19.99	4.99
BIO CHALLENGE	19.99	13.99
BRIAN CLOUGH'S FOOTBALL	24.99	8.99
BOMBUZAL	24.99	8.99
CAPTAIN BLOOD	24.99	8.99
CASINO ROULETTE	19.99	3.99
COLOSSUS CHESS X	24.99	14.99
CRASH GARRETT	19.99	3.99
CRAZY CARS II	24.99	14.99
DRILLER	24.99	8.99
ELIMINATOR	19.99	8.99
EMPIRE STRIKES BACK	19.99	8.99
ESPIONAGE	19.99	4.99
FALCON	29.99	18.99
GROWTH	14.99	3.99
HARDBALL	24.99	7.99
HOSTAGES	24.99	9.99
KING OF CHICAGO	29.99	9.99
KRISTAL	29.99	11.99
OPERATION NEPTUNE	24.99	9.99
PACLAND	24.99	9.99
PETER BEARDSLEY'S INT SOCCER	19.99	7.99
PURPLE SATURN DAYS	24.99	7.99
RETURN OF JEDI	19.99	8.99
RISING SUN	29.99	18.99
RUNNING MAN	24.99	14.99
SPITTING IMAGES	19.99	4.99
TEENAGE QUEEN	19.99	7.99
THREE STOOGES	29.99	8.99
TRIVIAL PURSUITS NEW BEGINNING	19.99	7.99
VINDICATORS	19.99	8.99
WANTED	19.99	4.99

### S.D.C. ORDER FORM (ZZAP NOVEMBER)

Type of computer	Amount
Title:-	
* Personal callers only	Total Enclosed £

Name .....

Address .....

.....

.....

Post code .....

Tel. no. ....

Please make cheques or postal orders payable to S.D.C.  
Orders under £5 please add 50p P&P. Over £5 P&P is FREE. Europe please add £1 per tape.  
Elsewhere please add £1.50 per tape.

VISA

Rorschach  
Scientific Stationary**RESEARCH PROJECT:** Binary code addiction as a means of controlling the world.**HEAD SCIENTIST:** Prof NORMAN NUTZ Phd, Bsc, KP.**RESEARCH EQUIPMENT:** C64, Amiga A500, Cray-2.**LAB ASSISTANT:** The Geek

*Well, I must admit I've been putting my feet up this month —only one game arrived for review, and as it was 'extremely interesting' Star Trek stuff the 'Trekkie' Ed decided to review it himself! So I'm temporarily unemployed —I did go down the Jobcentre, but they didn't have many vacancies for 113-year-old mad professors. Instead, they told me to 'bugger off and draw your pension, wrinkly!' —what a cheek; thanks to my own Nutz'Rejuvenation Potion I can still claim child benefit for myself!*

*Anyway, next month I will be re-employed—Ed Stu promises he won't hijack any more reviews (unless they're for Trekkie games!) —and I'll have a full review of Level 9's latest (and last) adventure, SCAPEGHOST (which just missed a review this issue). Until then, be adventurous.*

# STAR TREK: THE PROMETHEAN PROPHECY

MGA SoftCat/Simon and Schuster,  
C64 £14.95 disk only

**N**orman's Log,  
Stardate  
1254.3pm.  
Searching for  
strange new C64  
games is a long  
and rewarding  
process, but  
when you're

First Officer is someone as dumb as the Geek sometimes you have to acknowledge failure. On such occasions a bit of time travelling seems advisable, and with *Star Trek V* about to hit the UK I've set the dial for the 23rd century with a 1986 American release. And for an expert Trekkie's perspective I brought along the Ed . . .

Stuart's Log, Stardate  
1255.4pm. During routine  
exploration of uncharted space  
the USS Enterprise has been  
attacked by a Romulan Bird Of  
Prey. Severe damage has been  
suffered and, while crew injuries  
are miraculously light, the ship's  
food stocks have been  
contaminated. Chief Engineer  
Scott says repairing the warp  
engines will take eight days at  
least, so to avoid starvation a  
food source must be found  
quickly. Within impulse engine  
range is the apparently barren  
Prometheus Four planet.

To explore the planet a landing  
team is assembled including  
Kirk, Spock, McCoy and  
xenoethnologist (!) Hernanda  
Dimas. The team materialises  
near a mysterious obelisk,  
covered with a beautiful paisley  
pattern partially spoiled by weird  
graffiti. As the landing party  
explores, it encounters a swift-  
footed alien with quicksilver  
eyes, then a complicated alien  
culture ruled over by a  
mysterious Afflictor.

It's the fortunate idiosyncrasy  
of the Afflictor to gather together  
enormous quantities of krill in a  
big store house. If you could  
meet the Afflictor maybe you  
could negotiate, but the colour-  
coded gates to the central  
compound are closely guarded by  
Defenders wearing 'glassy,  
segmented armour of an evil,  
insectoid appearance.' and  
armed with a 'whip crowned with  
a blossom of curved glass  
needles.' The Prometheans can  
create glass by gathering together  
and humming at sand, which is  
useful since the Dune-like planet  
has little else. Clearly, popping  
down to a nearby planet to grab  
some food isn't going to be as  
simple as you might expect.

The screen display is split into  
three windows, one at the top

NEW CIVILIZATIONS.  
THE UNKNOWN PROMETHEAN WORLDS WILL  
INTO VIEW ON THE SCREEN BEFORE ME  
GLEAMING SPHERES, CIRCLING  
ENDLESSLY IN THE DARKNESS. AFTER  
ALL THESE YEARS PLANETS STILL LOOK  
LIKE TOYS TO ME, EACH ONE SMALL  
ENOUGH TO TAKE INTO THE PALM OF MY  
HAND, LIKE THE MODELS HUNG FROM THE  
CEILING IN MY ROOM AT THE ACADEMY.

AT TIMES LIKE THESE, I FIND MYSELF  
-MORE-

# LAB Report

**STAR TREK: THE PROMETHEAN PROPHECY**  
MOVES: 29  
BRIDGE

THIS, WHATEVER IT IS.

THE BIRD OF PREY'S GRACEFUL SWOOPING DESIGN OBSCURES ITS PURPOSE; YOU KNOW THIS VESSEL TO BE LITTLE MORE THAN A PLASMA "CANNON" WITH THE MOBILITY OF A STARSHIP. THIS ONE'S SCREEN IMAGE IS UNCOMMONLY VIVID, ITS OUTLINE OF ALMOST HALLUCINATORY CLARITY. THE EFFECTS OF ADRENALINE, NO DOUBT.  
-MORE-

**COMMAND**

//EXAMINE ATTACKER

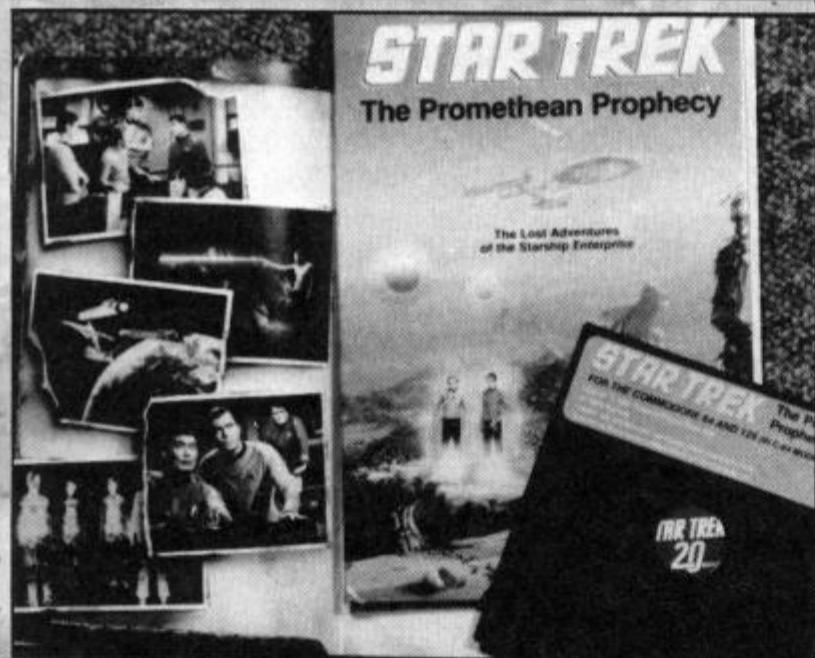

with location and number of moves info, the main text window, and the input window which allows only a single line of text. This is a fairly severe limitation on interaction, as is a limited vocabulary, which betrays the program's age. The actual game however, is still very good. The opening episode where you come under attack from the Romulan warship is incredibly tense, emphasising how little Kirk can do without a competent bridge crew. And once the Romulan captain is beaten, you find out he's the brother of the Romulan commander killed in the classic 'Balance Of Terror' episode.

Obviously the authors are Star Trek fans, and they so perfectly recreate the atmosphere of the series that you instinctively visualize its studio-confined planetscapes. The format of show is perfect for a computer game, phrases like 'energize' and 'standard orbit' allow complex commands to be simplified. Then there's the fact Kirk can't do everything himself, but must ask the other members of the landing party to do things. Characterization is good too - try and phaser a Defender and Spock restrains you by merely raising an eyebrow and suggesting it wouldn't be wise.

Personally I must admit to not being a great adventure fan, but the Star Trek theme of this certainly got me interested and thereafter it was a lot of fun. By comparison with Firebird's *Star*

*Trek*, which had superb graphics but little of the series' spirit with Klingon battlecruisers being destroyed by the dozen, this is much the superior Star Trek game. Non-fans might find the presentation technically poor, but the prose is excellent and gameplay simple enough to be ideal for beginners. I only hope the Star Trek V movie's as good, not to mention the computer game, of course.

Norman's Log 2053.8pm. What, Stu? You mean you've finished? Oh, thanks for a very interesting review. By the way, will I get paid for it? Only if I add my comments? Oh well, here goes . . .

I agree with the Ed totally and absolutely (can I have my money now? No?). *The Promethean Prophecy* has got an intense sci-fi atmosphere and despite its age (and its basic presentation) is still a great game. Even non-Trekkies (such as myself!) will enjoy this classic adventure.

*Star Trek: The Promethean Prophecy* is available from MGA SoftCat, Pear Tree, Appledore, Kent TN26 2AR, Tel: (0233) 83571.

ATMOSPHERE	90%
PUZZLE FACTOR	78%
INTERACTION	70%
LASTABILITY	82%
OVERALL	81%

# NEED A GUIDING LIGHT?

You know the feeling. There you are, playing an adventure, thinking you're doing really well when suddenly you come up against a solid brick wall. Several hours (and cups of coffee) later you still haven't fathomed out the problem. So what do you do? Well, you could always write to a Clever Contact, but if you want an immediate solution there's a very useful number you can dial.

Started four years ago, the Guiding Light adventure helpline 'turned professional' six months ago and now has ten lines, open from 12 noon to 8pm, seven days a week. Founder, Jacqueline Wright, says that the 'Adventure Rescue Team' (including the adventuring cat, Zork!) can offer help on over 300 adventures. Recently, Guiding Light have even received 'official approval' from several software companies who refer their callers to the helpline.

Guiding Light have had some teething problems such as broken underground ducts, floods, locked doors, and even a plague of mice (hence the acquisition of Zork). But despite these setbacks (which delayed the connection of the new phone lines by two weeks) the helpline is now going from strength to strength, receiving around 130 calls a day - a big prize is already being planned for the millionth caller!

If you need help, the number to ring is 0898 338 933 (calls cost 38p a minute, peak; 25p a minute, standard) - I'm sure I'll be ringing it myself from time to time!

## SCIENTIFIC SUGGESTIONS

with The

# GEEK

Cor, put me in a liquidiser and pour me into a pint glass! I've been totally amazed at the number of tips coming in. Please keep up the good work - even if your tips don't get printed they'll be kept in my moth-eaten files for invaluable future reference.

This month's £30 worth of software goes to Stuart Hardy of Sheffield for his brilliant guide to Infocom's RPG, *Battletech*. I must say, judging by the number of tips coming in for this one, perhaps old Norman missed something while reviewing it (he wasn't exactly enthusiastic about it!) as I found it interesting, although it does require a lot of patience to get anywhere - that's where the guide should come in useful!

Shard Of Inovar: To get the Amulet Of Fire . . . Get shard, invoke Ritual of Decaim (you

then get the vial) W examine the boulder and the sign, use the vial, examine tree, GIVE SHARD TO HOLE, N, get statuette, get shard, N, N, PLACE STATUETTE ON APERTURE, get statuette, N, get Ryxblade, PLACE STATUETTE ON FRONT, get statuette, get amulet, S, S, give Ryxblade to Laryx, S, S, W, mount Laryx.

Ingrid's Back: To open safe - TYPE 888155.

To get to the bottom of the well - First DROP BLUE TELELILY INTO WELL then drop Green Telelily on ground and GET ON GREEN TELELILY.

To contact Isfrunt - FLOPSY, GO TO BACK AND WAIT. Then WAIT 2 and KNOCK ON DOOR.

Beyond Zork: To slay the undead warrior, THROW VIAL AT WARRIOR after collecting it from the monastery.

Rigel's Revenge The adhesive patch and dinghy are a hoax and should be ignored. When the Sewer Monster looks hungrily at Harper he should FIRE FLARE at it.

Tass Times: Wear the mitts to take the devil, and use the Zagtone to free Gramps.

Fish: To get Focus Wheel . . . Go to the library (in the university) and look up the page with the focus wheel in the book found there. Tear out this page. Then use the Tatty Card to get into your laboratory and put the torn piece of paper in the slot in the photocopier (found in adjacent storeroom).

# THE GEEKY GUIDE TO BATTLETECH

Tips by **Stuart Hardy**

## At The Training Station

Go to the Comstar Station and invest all your money in Def Hes 'Mech manufacturing company to gain huge profits. The other two companies are unreliable and you will undoubtedly lose all your money!

Train once in Rifle Skills, then buy a submachine gun until you can afford a better weapon. Also essential for survival outside is a flak vest; this allows you to survive several hits before being wounded or dying.

Complete the training schedule until you reach the seventh mission. Four Kuritan locust 'Mechs will attack and destroy the base. Do not try and defeat them; it is impossible. Instead try escaping but if unsuccessful, well, you're on foot!



## The Starport

The Starport also has a Comstar Station for all your banking needs. Any money left over from the Training Centre's station will have been transferred here.

Go to the Arena (you need at least 250 C-bills to enter) to gain extra cash. Never shoot the spectator as this blows a hole in the Arena wall from which several deadly police 'Mechs will come. Using your own 'Mech in the Arena is inadvisable because your opponent will be armed with very powerful and long-range weaponry.

Going to the Starport with 'Mechs is very expensive and costs 150 in cash each time you leave.

## In The Wilderness

There are many cities around the landscape and they contain the usual buildings such as Hospitals, Mecht-Lubes and shops. One also has a Jail and Mayor's House.

Kuritan forces constantly patrol the cities and wilderness. One important thing to note is that there will be more members in enemy parties the bigger your own team becomes. Therefore the more 'Mechs there are in your group, the more will appear in future enemy patrols.

The advantage you have over the Kuritans is that while you can buy flamethrowers or missile launchers, the enemies are never armed with anything better than rifles.

The Kuritans can enter cities so be prepared for a few meeting engagements here – buying some civilian clothes will make you look less suspicious though.

To explore the landscape quickly, set the movement speed to the maximum and buy a terrain mapper. This will add more to the overhead map without you having to visit every single location.

## The Hermit

There is a hermit/inventor called Edward who lives alone in the wilderness. His house can be found at grid reference 49.20–36.40 from the map in the instruction booklet supplied with the game.

Edward will tell of a secret cave, somewhere southwest of his home, where a cache of 'Mech equipment is hidden – you must find this cache to complete the game.

To learn more of this mission, go to the Training Centre (after it has been destroyed) and enter the wrecked Barracks.

## The Cave

The cave is a huge complex of rooms and passages which hold the cache. It is located somewhere on a small island at grid reference 50.80–42.80 on the map.

To enter the cave you leave your 'Mechs outside and go in on foot. Fortunately, there are no Kuritan patrols here, so you can move with no fear of being ambushed.



## Blast Doors

There is a series of blast doors which can only be opened by finding the correct number code. Each piece of code is either Red, Yellow, or Blue, and one piece of each colour is needed to open the relevant door.

The code is obtained from strategically placed computer terminals each of which may only be used once. After a code is placed in the relevant door, the barrier opens to reveal more of the base which houses yet more doors and computer terminals.

## Cache And Final Code

While travelling around the base a wall should collapse, revealing a secret passage. At the end of this passage you should find Jeremiah Youngblood's 'Mech: a huge jet-like machine with arms and legs. Although Jeremiah is not inside his machine, this gives you new confidence in your quest to find him.

Somewhere in the base are a Generating Room and Laboratory, you will need to visit the former in order to switch on the power.

After opening all the doors, go to the rooms with the stairs and descend them. One set of stairs leads to the cache of 'Mech parts which will be useful in helping the House Of Steiner win the current Succession War.

The other stairway leads to a huge Starmap engraved on the floor, an illustration of which can be found on page 14 of the instruction manual. As you walk around this room, touching a planet will turn its symbol into a square - any planets in this state will be included in the final code.

The planets in this code are those which, in the instruction booklet, are covering the green area. These are Pesht, Benjamin, Skye, Ryerson, Kathil, Summer, and Achemar. The computer should acknowledge these planets as the correct password, allowing you to visit the Laboratory, here you will send a message to Katrina Steiner, telling her that you have found the cache.

A dropship will now arrive to transport you, your team, and the cache home - the mission has been completed!

## Recruiting Allies

**Rex** - At the Starport, go to the Hall while the meeting is in full swing to find Rex. He has a 'Mech, his Commando, waiting in the garage.

**Edward/Rick** - After finding Rex, go to the Starport's Mechit-Lube and ask about apprenticeship. Rex will meet his friend Edward who is willing to join you. However, Edward is a traitor so don't let him ride in the Commando 'Mech or he will sabotage it. Study his characteristics

and, before the next battle, Rex will kill him.

Rick is found in the same way (repeat above process) but he is genuinely a friend. He is an excellent tech and can obtain scrap metal, heat sinks, and weapons from destroyed enemy 'Mechs. If one of your own 'Mechs is destroyed, he has the knowledge to salvage, rebuild and repair it!

**Russ** - Russ is in jail at one of the cities and by entering this building your team will try and rescue him. While the battle with the Kuritan jailors rages, you must find Russ's 'Mech (parked in a nearby yard) and start its engine.

**Zeke** - By going to the Starport's Hospital and asking about the medical seminar, you will get Zeke to join your party. He is an excellent doctor and, when supplied with the necessary equipment, can heal any wounded members of the party as soon as combat is over.

## General Hints

1. If when in combat you decide to flee, always target all your weapons beforehand. This is so that if you don't make it you will still be able to fire back at the enemy and are not completely defenceless.
2. Fighting humans while in your 'Mech is easy, particularly as their weapons will hardly damage your machine! Do not waste missiles on foot soldiers, cut them down with lasers, kick them, or tread on them (for humorous results) instead. Humans will normally flee as soon as possible if pitched against your 'Mechs.
3. There is no point in searching through the medical records for Jeremiah Youngblood's name because you do not even find him at the end of the game, although you believe that he is still alive.
4. Men untrained in 'Mech piloting will not be able to drive these machines so they should be placed on foot and armed with missile launchers, not infernos. While infernos only raise an enemy 'Mech's heat level by a little, the missiles will help to destroy it.
5. People can only be trained so well in Technical and Medical skills, so excellence in these skills will never be reached.

# CLEVER CONTACTS

Stuck in an adventure? Being driven up the wall? Well despair no more, simply send details of your problem plus a stamped, self-addressed envelope to one of the friendly folks below (or ring if there's a phone number). They'll only be too glad to help you.

Heroes of Karn, Bored of the Rings, Gremlins, Voodoo Castle, Zim Zala Bim, Mugsy's Revenge, Tropical Adventure, Dracula, Holy Grail, The Pawn, Return to Oz, Masters of the Universe, Robin of Sherwood, Fourth Protocol, Price of Magic, Christophe Brassart, 67 rue de l'Abbe Lemire, 59200 TOURCOING, France.

Tower of Despair, Dracula, Adventureland, Zim Zala Bim, Castle of Terror, Time Tunnel, Eureka, John Paterson, 8 Bracadale Road, Baillieston, Glasgow G69.

The Golden Baton, Worm in Paradise, Hobbit, Fourth Protocol (Pt 3 only), Andrew Blackman, 133 Ashen Drive, Dartford, Kent DA1 3LY. Tel: 0322 76887 5.30-8.30pm

Dungeon Adventure, Lord of the Rings, Quest for the Holy Grail, Hampstead, Lords of Time, Inca Curse, Espionage Island, Planet of Death, David Lemon, 14 Norton Place, Dunfermline, Fife KY11 4RH. Tel: 0383 728353 after 6pm Mon-Fri

Leather Goddesses of Phobos, Zork III, Terrormolinos, Never Ending Story, Heroes of Karn, Mission 1, Gremlins, Robin of Sherwood, Ron McKenzie, 3 Silverstream, Freystrup, Haverfordwest, Dyfed SA61 2SN.

Adventureland, Subunk, Heroes of Karn, Empire of Karn, Munroe Manor, Hacker, Classic Adventure, all

early Infocom titles, Jinxter, Guild of Thieves, Plundered Hearts, Dracula, Hitchhiker's Guide, Mindshadow, Tracer Sanction, Wishbringer, Trinity, The Pawn, Chris Fleming, 235 Meola Road, Pt Chev, Auckland, New Zealand. Tel: 867074

Voodoo Castle, Heroes of Karn, Pirate Adventure, Ten Little Indians, Hobbit, Lost City, Gremlins, Wizard of Akyrz, Quest for the Holy Grail, Zim Zala Bim, Island Adventure, Castle Dracula, Paul Flanagan, 6 Corry, Belleek, Co Fermanagh, N Ireland. Tel: 036565 594

The Hobbit, Erik the Viking, Castle of Terror, Eureka, Voodoo Castle, The Count, Heroes of Karn, Empire of Karn, Zork I, Zork II, Zork III, Exodus, Ultima III, Ultima IV, Ultima V, The Boggit, Never Ending Story, The Hulk, Seabase Delta, Kentilla, Valkyrie 17, Sherlock, The Fourth Protocol, The Helm, Wizard of Akyrz, Perseus and Andromeda, Lord of the Rings, Quest for the Holy Grail, Hacker, Starcross, Moonmist, Frankenstein, Winter Wonderland, Imagination, Jack The Ripper, Leather Goddesses of Phobos, The Pawn, Borrowed Time, Déjà Vu, Planetfall, Hitch Hikers Guide To The Galaxy, Duddy Geezers, Tass Times in Tone Town, Return To Eden, Snowball, Worm in Paradise, Stationfall, Steven Kelly, 4 South View, Whins Lane, Simonstone, Burnley, Lancs BB12 7QU. Tel: 0282 74765 (between 6pm and 10 pm)

The Hobbit, Seabase Delta, Kentilla, Zzzz, Spytrek, Robo City, Imagination, Demon Knight, Kobayashi Naru, Tower of Despair, Time Tunnel, Citadel of Chaos, Eureka, Sorcerer of Claymorgue Castle, The Quest For The Holy Grail, Rigel's Revenge, See-ka of Assiah (part one), Football Frenzy, Velnor's Lair, Paul Hardy, 33 Fir Tree drive, Wales, Sheffield S31 8LZ.

Hitchhiker's Guide, Zork I, Zork II, Planetfall, Leather Goddesses, Cutthroats, Infidel, Stationfall, Dave Rogers, 15 Elm Terrace, Westfield, Radstock, Bath, Avon BA3 3XP.

Ultima IV, The Bard's Tale, Voodoo Castle, Phantasia I, Never Ending Story, Dracula, The Prince of Magic, Borrowed Time, The Pawn, Seabase Delta, Deadline, Zork III, Wishbringer, Derek Wong, 42 Ingram Road, Thornton Heath, Surrey, CR4 8EB.

Hitchhiker's Guide, The Hobbit, Lord of the Rings, The Shadows of Mordor, Guild of Thieves, Jinxter, Warren Lee Mellia, 1 Thornhill Avenue, Rishton, Blackburn, Lancs, BB1 4EZ.

Jack The Ripper, Dracula, Kayleth, Mindshadow, Never Ending Story, Derek Scott, 42 South Parade, Leven, North Humberside HU17 5LJ.

Starcross, Suspended, Suspect, Leather Goddesses, Zork I, Zork II, Zork III, Deadline, Planetfall, Infidel, Cutthroats, Ballyhoo, Lurking Horror, Seastalker, Bureaucracy, Trinity, Moonmist, Hollywood Hijinx, Hitchhiker's Guide, Wishbringer, Sorcerer, Spellbreaker, Enchanter, The Pawn, Ultima I, Ultima III, Ultima IV, Sherlock, Gremlins, The Hulk, Terrormolinos, The Fourth Protocol, The Hobbit, Billy Kavanagh, 49 Drake Hall, Westthoughton, Bolton, BL5 2RA.

Never Ending Story, Zzzz, Quest for the Holy Grail, Tony Kinnear, 49 Wainwright Avenue, Hutton, Brentwood, Essex, CM13 2SZ.

Bally Hoo, Bored of the Rings, Borrowed Time, Deadline, Emerald Isle, Enchanter, Eureka (German, Arthurian, Roman), Gremlins, Hitchhiker's Guide to the Galaxy, The Hobbit, Leather Goddesses of Phobos, Mind Shadow, Munroe Manor, Moonmist, Pirate Adventure, Planetfall, Planet of Death, Knight Orc Pt 1, Seastalker, Ship of Doom, Spell Breaker, Spiderman, Starcross, Stationfall, TassTimes, Lurking Horror, Tracer Sanction, Valkyrie 17, Very Big Cave Adventure, Wishbringer, Worm in Paradise, Zork I, Zork II, Zork III, Ian Gay, 18 Earsdon Close, Westdunton, Newcastle upon Tyne, NE5 5AL.

SMASHED, Seabase Delta, Frankenstein, Kentilla, Quest For The Holy Grail, Sporne Ranger I, II, Eureka I, II, III, IV, Zim Zala Bim, Cricket Crazy I, Kobayashi Naru, Scott West, 30 Charnock Dale Rd, Gleadless, Sheffield, S12 3HF (No more phone calls, please)

The Hobbit, Seastalker, Trinity, Leather Goddesses, Bureaucracy, Hitchhiker's Guide, Stationfall, Carl Kutteiwasher, 6 Robin Hill Drive, Camberley, Surrey, GU15 1EG.

Enchanter, Zork I, II, III, Planetfall, Stationfall, Plundered Hearts, The Pawn, Shadowgate, Wishbringer, Leather Goddesses of Phobos, Ingrid's Back, Hollywood Hijinx, Julian Loveday, 23 Herbert Road, Emerson Park, Hornchurch, Essex, RM11 3LM.

Heroes Of Karn, Empire of Karn, Dracula, Seabase Delta, Spiderman, Hulk, Zzzz, Quest for the Holy Grail, Lord of the Rings, Price of Magic, The Pawn, Twin Kingdom Valley, A Ridge, 4 Corwallis Avenue, Clifton, Bristol, BS8 4PP.

Twin Kingdom Valley, The Hobbit, Hitchhiker's Guide, Return To Eden, Terrormolinos, Dallas Quest, Jinxter, Déjà Vu, Shadowgate, The Three Musketeers, Plundered Hearts, Steven Coomber, 6 Maysfield Close, Portishead, Bristol, BS20 9RL. Tel: 0272 844218 (6-9pm)

The Boggit, Hulk, Kayleth, Kobayashi Naru, Sherlock, William Stephenson, 10 Inchcolm Terrace, South Queensferry, West Lothian, Scotland, EH30 9NA.

Corruption, TassTimes in Tonetown, King's Quest III, Simon Ball, 1A Castle Flats, South Street, Ashby-de-la-Zouch, Leicestershire, LE6 5BQ. Tel: 0530 415103 (5-10pm)

Zork II, Gnome Ranger, Knight Orc (part one), Steve Parker, 13 Elizabeth Road, Seaton, East Devon, EX12 2DS.

Zork I, II and III, Suspended, Starcross, Deadline, Gruds in Space, Hulk, Spiderman, Asylum, Dallas Quest, Wishbringer, Hollywood Hijinx, Rigel's Revenge, Mischa Schweitzer, Assumburg 9, 1121 EA Landsmeer, Holland.

Knight Orc, Mindshadow, Bastow Manor, Dracula, Never Ending Story, Jamie Gooding, 29 Ross Street, Surrey Hills, Victoria 3127, Australia.

Football Frenzy, Cricket Crazy, Mindshadow, The Quest For The Holy Grail, Se-kaa Of Ashiah (part 1), Never Ending Story, Kentilla, Zzzz, Time Tunnel, Castle Of Terror, Peter J.R. Laws, 60 Standard Rd, Enfield, Middlesex, EN3 6DP.

Time Tunnel, Quest For The Golden Egg, Spiderman, Wolfman (all parts), Kevin Moffat, 54 Parsonspool, Dunbar, East Lothian, EH42 1JH.

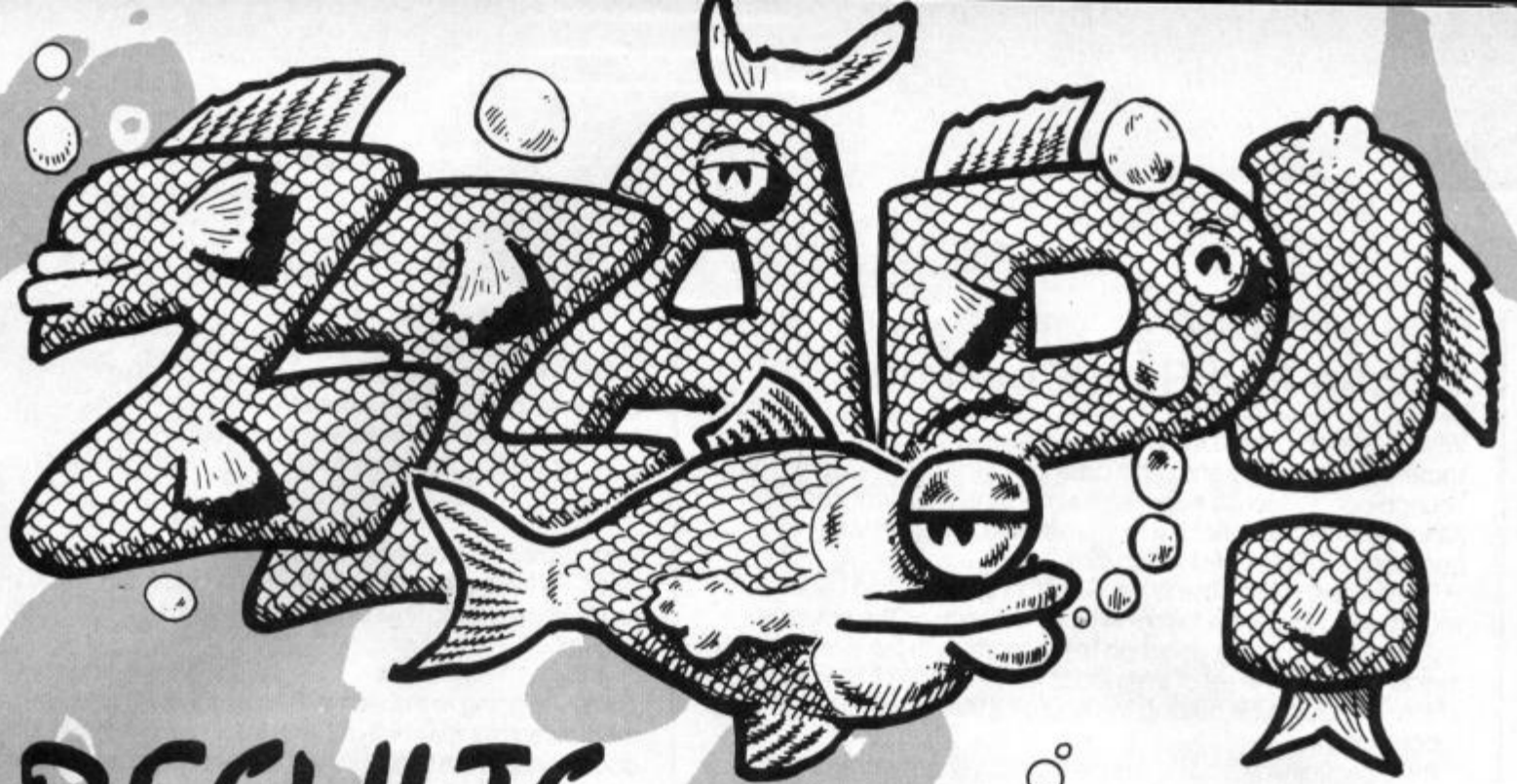

# RESULTS with Ken the Fish

Here I am, back again after my little holiday with all the latest results. I think the last issue of ZZAP! was great but it definitely lacked something without yours truly to add a bit of fishy fun. So here I am again!

You know, a lot of people ask me, 'Ken, how come you're sooo cool?'. Of course the simple answer is that you would be too if you always went round stark naked! It doesn't half get chilly in the winter though, so here's my

special knitting pattern for a fab sweater, specially designed to fit most types of fish . . .

k4-p1-k3-p2-k4-p1-c1-hi-k4-p1-do-es-k4-p1-an-yo-ne-k3-p2-ta-ke-k4-p1-th-is-c2-p2-se-ri-ou-sl-y?!

Sew it together to make a perfect Christmas gift for your fave fish. Now for those results . . .

## GREEN BOGEY COMPETITION (Again Again, Issue 50)

I have an octopus friend who does Humphrey Bogart impressions. I don't really, I just thought it would be a clever link to this compo. No? Oh, suit yourself, then. Ten winners are

to receive a Gilbert Goody Bag, comprising a copy of the game, a Gilbert T-Shirt, a joke book and a bendy Gilbert among other items. Stand up and be counted:

Simon Beard, BRISTOL BS12 1UE; Louise Dennis, TELFORD TF3 1YR; David Stewart, CORSHAM SN13 9JD; Ronald Ashford, STURMINSTER NEWTON DT10 2HR; Richard Court, RAMSGATE CT11 7BP; Richard Heaton, RUGBY CV21 4AT; Neal Todd, WARMINSTER BA12 9QU; Mark Goble, ROCHESTER ME1 3RJ; David Exton, STAFFORD ST16 3SG; Andrew Potts, KINGSWINFORD DY6 8NY.

## IT'LL BE MY LAST CRUSADE IF I DON'T WIN THIS INDY COMP!

(US Gold, Issue 52)

The winner receives a Commodore 1084S Monitor for use with either the C64 or Amiga. And an Indiana Jones Archaeological Pack (8 bit or 16 bit) which contains the Indiana Jones Arcade Game, an official film poster, the book-of-the-movie, and an

Indy sweatshirt. And the lucky reader is . . .

Edward Grigg, Hatfield AL10 8PE.

15 runners-up receive an Indiana Jones Archaeological Pack:

Matthew Faizey, Birmingham W.Mids; Martin Hunn, London E16 1NH; David Washer, Middlesex HA9 9SL; Dean Tiller, Bournemouth BH11 8RR; Jay Miscombe, Wymondham NR18 9SN; Stephen Connor, Waltham Abbey EN9 1NA; Mark Shaw, Cannock WS12 4SZ; David Sankey, Wigan WN2 4JD; Saiful Abedin, London E7 8LB; Andrew Checker, Bristol BS5 9ED; Michael Tomlin, Hemel Hempstead HP2 5PA; Andrew Spencer, Wakefield WF4 2DP; Troy Helm, Carmarthen Dyfed; Jamie Lee Smith, Doncaster DN4 6RW; W M Taylor, Tunis Barricks BFPO 22.

## A JOY TO STICK WITH POWERPLAY

(Powerplay, Issue 51)

The good thing about Alton Towers is that it has a really big lake for me to have a long, relaxing splash in. Especially after being cooped up in a bag all day, waiting to be won at one of the sideshows. The two first prize winners were treated to an all expenses day out at Powerplay and helped to make a joystick before travelling to Alton Towers for

an afternoon of whooping it up:

Mark Collins, WA4 5DX; Mark Essen, HD7 3DL.

Five runners-up who weren't lucky enough to win the first prize, but who were still rather lucky anyway, receive a Powerplay Crystal joystick:

Andrew Capper, PE11 3AF; Antony Micallef, SN31 5EQ; Crispian Cook, GU4 7JF; Adam Brown & Arran Cooper, CB4 2NS; Neil Hudson, CW4 7NS.

## POWERDROME HOTLINE COMPETITION

(Electronic Arts, Issue 51)

Vroom, vroom! The speedy winner gets a fantastic Scalextric set. The lucky driver is:

Neal Todd, Warminster BA12 9QU.

30 runners-up receive a game

of their choice - (20 for the C64 and 10 for the Amiga, or rather, they would have done if enough people had entered. Shame on the rest of you - for the price of a phone call you could have won a free game! Oh well, here are the runners-up . . .

Robert Fay, St Neots PE19 3LN; Alan Butterworth, Bolton BL6 7DW; Stuart Wooten, Bath BA1 6LY; John Hamilton, Witney OX8 6QY; Jonathan Hudson, Sunderland SR5 1HW; Gregiz M Bullard, Dunbar EH42 1QT; Gary Nichols, Wirral L63 5JU; Martin Hunn, London E16 1NH; L McMahan, Dunstable LU5 5PG.



# THE RACING GAME

AN EXCITING GAME DESIGNED FOR THE HORSE RACING ENTHUSIAST. MANAGE 15 HORSES TO WIN GROUP, GRADED AND OPEN RACES. SEASON INCLUDES:

**THE DERBY - 1000/2000 GUINEAS - THE OAKS - THE ST LEDGER**

FORM, FITNESS, GOING, DISTANCE, ALL EFFECT RESULTS. TRAIN YOUR HORSES. FULL SEASON OF 80 RACES OR QUICK GAME OPTION. GIVE THE RIDING INSTRUCTIONS TO YOUR JOCKEY. SEE YOUR SEASONS RESULTS AND FINANCIAL STANDING. FULL BETTING MARKET, PRE RACE REPORTS, STEWARDS ENQUIRIES, RENAME HORSES, RACES OVER 5F TO 2½ MILES. WATCH THEM RACE AND CHEER HOME YOUR HORSE

COMMODORE TAPE £7.95    COMMODORE DISK £8.95  
SPECTRUM TAPE £6.95

AVAILABLE BY MAIL ORDER ONLY SEND CHEQUE/P.O. TO.

TANGLEWOOD SOFTWARE DEPZZ, 157 WARWICK ROAD, RAYLEIGH ESSEX SS6 8SG

Proprietor: J MOSS

## AT LAST! COMMODORE I/C SPARES

AT DISCOUNT PRICES

For C64, C16, +4, C128 and Amiga

CIA	6526	£9.99	ROM	901227-03	£8.99
MPU	6510	£9.99	ROM	901225-01	£7.99
PLA	906114-01	£9.99	SOUND	6581	£14.99
ROM	901226-01	£12.99	RAM	4164	£2.99

C64 USER PORT RE-SET SWITCHES £5.49

MICRO MATE REPAIRABLE C64 POWER SUPPLY UNITS. SUPERB QUALITY WERE £29.99 NOW £24.99

C64 TAPE TO TAPE BACK-UP INTERFACE £9.99

All prices include post & packing, handling and VAT—send your faulty computer and P.S.U. for estimate and repair from £9.99 + parts + carriage + VAT.

SEND CHEQUE/P.O.    ACCESS/VISA CARDS WELCOME

## ELECTRONIC SERVICES

176 VICTORIA ROAD WEST, CLEVELEYS, BLACKPOOL, FY5 3NE  
Tel. (0253) 822708

Dear Sir,  
I'd like to complain about this advertisement because

Most advertisements are legal, decent, honest and truthful. A few are not, and, like you, we want them stopped.

If you would like to know more about how to make complaints, please send for our booklet: 'The Do's and Don'ts of Complaining'. It's free.

**The Advertising Standards Authority** ✓

ASA Ltd., Dept. Z, Brook House, Torrington Place, London WC1E 7HN

## ADVENTURE HELPLINE



Do you play computer adventures? Have you ever been faced with a seemingly impossible situation?

**WE CAN HELP**

Our adventure rescue team work 7 days and 7 evenings a week and will be pleased to answer your queries.

We offer help with any games or any computer - so if you are tearing your hair out ring this number now!

**0898 338 933**

T.M.E.P. 10b Hulme Hall Road, Manchester M15 4LY

Calls charged at 25p min 'cheap' rate/38p at all other times

Pick up the phone, and enter

# The Fortress Of Doom



Are you brave enough to explore this sinister fortress? Can you outwit the creatures of evil who haunt its halls and deadly dungeons?

To play this thrilling role-play adventure game, just dial the number below.

Listen to the narrator.

Choose your actions by speaking to our unique voice-activated computer. Hidden prizes await all who triumph.

Phone now . . . if you dare!

**0898  
555 525**

For special game card and rules, send s.a.e. to PhoneQuest, Broadsystem Ltd, Elephant House, London NW1 8NP. Calls cost 25p per minute cheap rate, 38p per minute at other times.

# FREE Catalogue

## VideoVault

### COMPUTER COMPANION

### RED HEAT

**SOFTWARE**  
All the leading software for your computer—Spectrum, Commodore 64, Amiga, Atari ST, BBC, Sega plus many more.

**HARDWARE**  
Printers, Disc Drives, Light Pens, Snapshot, Reset Switches, Freeze Frame MK5, Mouse, Light Guns.

**JOYSTICKS**  
We have a large range of Joysticks from all the leading Manufacturers—Phasor One "125" "Challenger" "Mach 1" "Starfighter" "Competition Pro" "Konix Auto Fire" "Cruiser" "Sega Joystick" plus many more.

**BUSINESS SOFTWARE**  
Statements, IBM Software, Head Cleaners, Disc Boxes, Mouse Mat, Invoices, plus large selection of Amstrad/IBM Business programmes.

**BLANK MEDIA**  
3" Discs, 5¼" Discs, 3½" DS/DD Discs for all computers.

Just send us 3 x 19p stamps for your free copy of the Computer Companion—over 24 pages of all the latest in Hardware & Software. 24 hour delivery or you can order by phone using Access/Visa.  
**Send for your Copy Now.**

**VideoVault LIMITED**  
VideoVault Limited, Old Kingsmoor School, Railway Street, Hadfield, Cheshire SK14 8AA. Telephone: 04574 66555/67761/69499. Fax: 04574 68946.

© COPYRIGHT VIDEOVAULT 987071

# THALAMUS



The greatest journey  
is about to begin...



## CINTRONICS LTD STRATEGY ADVENTURES & SIMULATIONS

Commodore 64/128 discs

SSI		INFOCOM	
50 MISSION CRUSH	£11.95	BALLYHOO	£11.95
BATTLE GROUP	£22.95	BUREAUCRAZY C128	£11.95
BATTLE OF ANTIETAM	£22.95	HITCHHIKERS GUIDE	£11.95
BATTLES OF NAPOLEON	£17.95	LEATHER GODDESSES	£11.95
CURSE OF AZURE BONDS	£17.95	WISHBRINGER	£11.95
DEMONS WINTER	£14.95		
ETERNAL DAGGER	£14.95	AMIGA	
FIRST OVER GERMANY	£17.95	BREACH	£14.95
FORTRESS	£11.95	DEMONS WINTER	£22.95
GEOPOLITIQUE 1990	£11.95	EMPIRE	£22.95
HEROES OF THE LANCE	£12.95	FIREBRIGADE (1MB)	£26.95
HILLS FAR	£14.95	GETTYSBURG	£26.95
NAM	£12.95	GRIDIRON	£26.95
OVERRUN	£17.95	HEAD COACH	£34.95
PANZER GRENADIER	£22.95	KAMPPGRUPPE	£22.95
PANZER STRIKE	£22.95	PALADIN	£14.95
PHANTASIE III	£14.95	PHANTASIE II	£19.95
POOL OF RADIANCE	£17.95	QUESTRON II	£19.95
PRESIDENT ELECT 88	£12.95	RACTER	£22.95
QUESTRON I	£14.95	REACH FOR THE STARS	£22.95
QUESTRON II	£14.95	REBEL CHARGE	£26.95
REBEL CHARGE	£22.95	ROADWAR 2000	£19.95
RINGS OF ZILFIN	£14.95	ROADWAR EUROPA	£19.95
ROADWAR EUROPA	£14.95	STAR FLETT I	£22.95
SHARD OF SPRING	£14.95	UMS	£17.95
SIX-GUN SHOOT OUT	£11.95		
SONS OF LIBERTY	£22.95		
STORM ACROSS EUROPE	£17.95		
WAR GAME CONSTR. SET	£14.95		
WARSHIP	£22.95		

CLUE BOOKS: £6.95 each: BLACK CAULDRON, GOLD RUSH, KINGS QUEST I, II or III, LEISURE SUIT LARRY I or II, MANHUNTER, POLICE QUEST I or II, SPACE QUEST I, II, or III

£7.95 each: BARDS TALE I, II or III, DEATHLORD, DUNGEON MASTER, FAERY TALE, HEROES OF LANCE, HILLSFAR, MANIAC MANSION, MARS SAGA, MASTERS COLLECTION (Black Silver & LA Crackdown), MIGHT & MAGIC, NEUROMANCER, POOL OF RADIANCE, WASTELAND, or ZAK McKRACKEN

£8.95 each: ULTIMA III, IV or V.

Mail order only. Please allow 28 days for delivery. Please make cheques and postal orders payable to CINTRONICS LTD. Free post and packaging within the UK. Europe add £2 per item. Overseas £4 per item.

CINTRONICS LTD, RICHARD HOUSE, 30-32 MORTIMER ST, LONDON W1N 7RA

## COMMODORE 64 REPAIRS & SPARES

OR BRING IT  
TO US FOR  
WHILE-U-WAIT  
REPAIRS -  
AROUND 1 HR

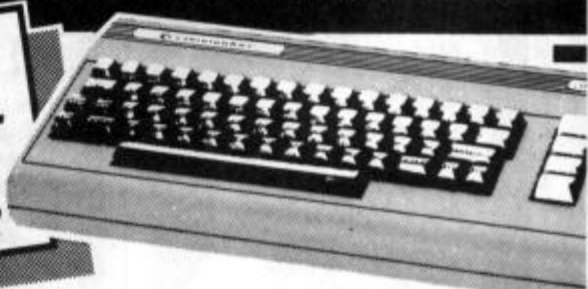

**NEED YOUR COMPUTER REPAIRED FAST?  
FED UP OF WAITING WEEKS FOR YOUR COMPUTER TO ARRIVE?**

**THEN WAIT NO LONGER**-send your computer to us for fast repairs!  
We offer a full repair service on all these makes-Commodore 128, Commodore 16, Commodore Plus 4, Vic 20.

We also have spare parts available by mail order.  
**WE DON'T JUST REPAIR YOUR COMMODORE 64**-we check loading, sound, memory, in fact fully overhaul your computer for only **£40.00** - which includes VAT, postage + packing, insurance, parts and labour. **NO HIDDEN EXTRAS.** All other models please call us for a quote on the numbers below.

**HOW TO SEND YOUR COMPUTER**  
Just pack your computer, including power supply, in suitable packaging and send it to the address below, enclosing your cheque to the value of **£40.00**-You can also pay by ACCESS/BARCLAYCARD



**VideoVault**  
LIMITED

**COMMODORE 64/  
VIC POWER  
SUPPLY UNIT**



Developed by us - is 1/2 size of conventional power supplies. Just **£35.00** + £2.00 p + p



Send your computers now to-  
VideoVault Ltd, Old Kingsmoor School, Railway Street, Hadfield, Cheshire SK14 8AA  
Telephone: 04574 66555/67761/69499

© Copyright VideoVault Ltd. No. 987092

Fax: 04574 68946

# CRYSTAL MIGHTY!

Win a superb satellite system from Powerplay!!!

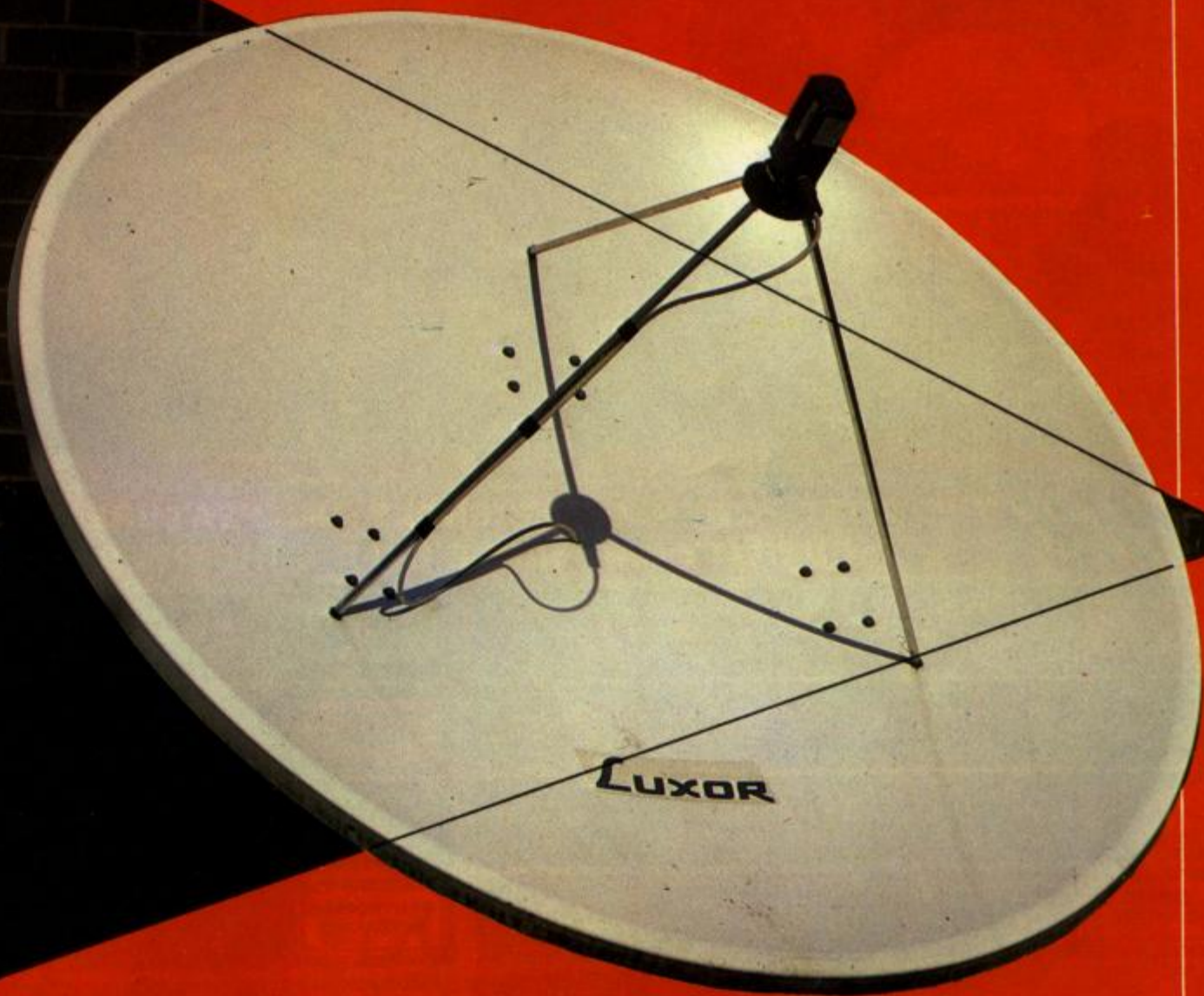

Fed up with the four normal TV channels? Fancy having programmes beamed down from space? Well now you can join the satellite revolution. **Powerplay**, makers of arguably the finest joysticks in the universe, are giving away a brilliant Amstrad Satellite System to celebrate the success of their Crystal joystick.

The stick originally got its name from the fact that it was made from clear plastic, but now Powerplay have added new solid-coloured sticks to the range in raging red

and glorious green. Complete with microswitches for ultra-accurate control they are an essential piece of equipment for the serious gamesplayer.

They're also extremely durable – that's why, along with Powerplay's other brilliant stick, the Cruiser, they're so popular in the ZZAP! office where sticks come in for a lot of punishment!

They've even survived the famous 'desk bash' technique which so many reviewers use to boost their gamesplaying performance!

As well as the amazing first prize of an Amstrad satellite system, comprising dish and tuner, Powerplay are generously offering 20 Crystal joysticks – ten Standard and ten Turbo (with autofire) to the lucky runners-up. And all you have to do to stand a chance of winning a power-prize is answer the three ever-so-simple Crystalline questions below . . .

1. Which long-haired country singer had a hit with 'Don't It Make My Brown Eyes Blue'?

2. What is the glass globe used by fortune-tellers?

3. What is the name of Blake Carrington's wife in *Dynasty*? (And the answer isn't Mrs Carrington!)

Got 'em all? Then scribble the answers on the back of a postcard or sealed envelope and send it to COLOURFUL CRYSTAL COMP, ZZAP!, Ludlow, Shropshire SY8 1DB.

Usual competition rules apply and entries must be received by 23rd November at the very latest.

THE ULTIMATE UTILITY CARTRIDGE COMES OF AGE!

NOW **ACTION REPLAY Mk VI** IS HERE

FOR CBM64/128

THE ACTION REPLAY  
MK VI WILL LOAD  
A 200 BLOCK  
PROGRAM  
IN UNDER 6  
SECONDS

ONLY  
**£34.99**  
POST FREE

WARNING:  
1988 COPYRIGHT ACT

Datel Electronics neither condones or authorises the use of its products for the reproduction of copyright material. The back up facilities of this product are designed to reproduce only software such as public domain material, the users own programs or software where permission to make a back up has been clearly given. It is illegal to make copies, even for your own use, of copyright material, without the expressed permission of the copyright owner, or their licensee.

**THE MOST POWERFUL, FRIENDLY AND FEATURE PACKED UTILITY CARTRIDGE EVER CONCEIVED!**

**TURBO  
LOADER**

Load 202 block program in under six seconds - world's fastest disk serial loader. On-board Ram and Rom achieves such high loading speeds. Works with 1541/1571/Oceanic/1581.

**TAPE  
TURBO**

This feature will add Turbo Reload to the programs that you save to tape - no user knowledge required.

**INFINITE  
LIVES  
GENERATOR**

Automatic infinite lives!!! Very easy to use, works with many programs. No user knowledge required.

**FAST  
FORMAT**

Format an entire disk in about 10 seconds - no more messing about.

**PROF  
MACHINE  
CODE MONITOR**

Full 64K Freezer Monitor - examine ALL memory, including stack, I/O area and registers in their frozen state. Ideal for debugging or just for fun!

**PRINTER  
DUMP**

Print out your frozen screen to printer - MPS 501, 503, Epson, Star, etc. - very versatile.

**SPRITE  
CONTROL**

Freeze the action and view the sprites - watch the animation - customize your games - kill sprite collisions.

**CENTRONICS  
INTERFACE**

For parallel printers, Star, Epson, etc. Print out listings with graphic characters etc. (Cable required for parallel port £12.99).

**FREEZER  
FACILITY**

Now you can make your old slow loading programs load faster. Simply freeze the action and save to tape or disk to reload at superfast speed - no more waiting for programs to load.

**SCREEN  
EDITOR**

Now you can edit the entire frozen screen with this text editor - change names on high scores, etc. Great fun!

**DISK COPY**

Easy to use disk/file copier. Much faster than conventional methods. Ideal for backing up data disks.

**EXTENDED  
TOOLKIT**

Many single stroke commands for Load, Save, Dir, etc. Plus range of extra commands, i.e. Auto Number, Old, Delete, Merge, Append, Linesave, etc.

**THE REVIEWERS SAY**  
"I'm stunned, amazed and totally impressed. This is easily the best value for money cartridge. *The Cartridge King!*"  
Commodore Disk User



**THE ACTION REPLAY MK VI IS NOT ONLY THE WORLDS FASTEST TURBO LOADING CARTRIDGE BUT IT IS PACKED WITH ALL THE FEATURES YOU HAVE EVER NEEDED AND THEN SOME MORE!!!**

**HOW TO ORDER...**

ALL ORDERS  
DESPATCHED  
WITHIN 48 HRS

**PHONE**

0782 744307  
24hr Credit  
Card Line

**POST**

Send cheques/POs made payable to "Datel Electronics"

**FAX**

0782 744292

UK ORDERS POST FREE  
EUROPE ADD £1  
OVERSEAS ADD £3

PRICES AND SPECIFICATIONS CORRECT AT TIME OF PRESS  
AND SUBJECT TO CHANGE WITHOUT NOTICE

**DATEL  
ELECTRONICS**

DATEL ELECTRONICS LTD.,  
FENTON INDUSTRIAL  
ESTATE  
GOVAN ROAD, FENTON,  
STOKE-ON-TRENT,  
ENGLAND.

TECHNICAL  
PHONE LINE  
0782 744324

**GRAPHICS SUPPORT  
UTILITIES DISK**

**SLIDE SHOW.** View your favourite screens in a slide show type display.  
**BLOW UP.** Unique utility allows you to take any part of a picture & 'blow it up' to full screen.  
**SPRITE EDITOR.** A complete sprite editor helps you to create or edit sprites.  
**MESSAGE MAKER.** Any screen captured with Action Replay or created with a graphics package can be turned into a scrolling screen message with music.

**ONLY £9.99**

# ZZAP! Rrap

The hands know...  
Rabour...  
I ♥ 30

ZZAP! IS  
ON THE R...  
ZZAP! IS  
ON THE R...  
ZZAP! IS  
ON THE R...

Well, the summer's been and gone although I must admit it was a pretty good one. It was so sunny that even I was tempted to try and obtain a suntan by swapping my paper bag for a polythene one - unfortunately within a couple of minutes, instead of a nice golden brown, my face had turned a bright shade of blue! I blame it on the depletion of the ozone layer myself, and topically, this month's Rrap is not without a contribution to the 'Green' debate.

## AN ORIC REVIEW!

Dear Lloyd,  
While programming my Epic (Ehem!) computer game, I noticed the latest copy of ZZAP! (No. 53) had just arrived on my doorstep!  
I was just flicking through its hallowed pages when I realised to my extreme horror that you were criticising the incredible Oric super computer!!! How dare you! The Oric is 100% Cray compatible! It has the overall power and speed of a 1,000 Amigas glued together!  
I feel it is my supreme duty to defend the sacred name of Oric and write a review of one of its numerous pieces of software! So here it is! But I must confess I ran into a few difficulties, firstly there was the problem of software, which was that there isn't any! But only a wimp would complain about that. *Real* gamers write their own. Now, what program could possibly take full advantage of the Oric's capabilities? I know I could do an Oric version of the classic Amiga flight simulator *Falcon*!  
Secondly, I don't actually have an Oric but I can simply get around this by writing the program on my good ole 64 in Basic then I can just convert it onto Oric format!  
Enough of this idle chat and on with the review!



Simon Bone Enterprises, Oric £56.99 (cheques made payable to me!)

●State of the Art computer gaming!

Right now for the scenario. How about this. You fly a plane, you shoot down other planes. Er, okay so that's basically it!

The first thing that strikes me about playing this game is the incredible graphics, it even allows up to 2 colours on the screen at the same time!!! Yes it's actually true! OK so it might only be black and white but this gives the incredible illusion of flying at night! The filled-in 3-D graphics are stupendously fast and move at approx 2

frames a minute!!! Stewrth! Even an Amiga 2000 couldn't come close to that! But hold on the shocks aren't over yet! The enemy plane actually fires back! Yes I don't know how they've done it but the plane actually fires back! It must have taken weeks, but it's really been done (10 mins actually!). I had to keep reminding myself that I was just playing a computer game and not flying an ultra fast jet, as the black and white landscape is that realistic!!!  
Some critics of the game complain that it has no sound effects,

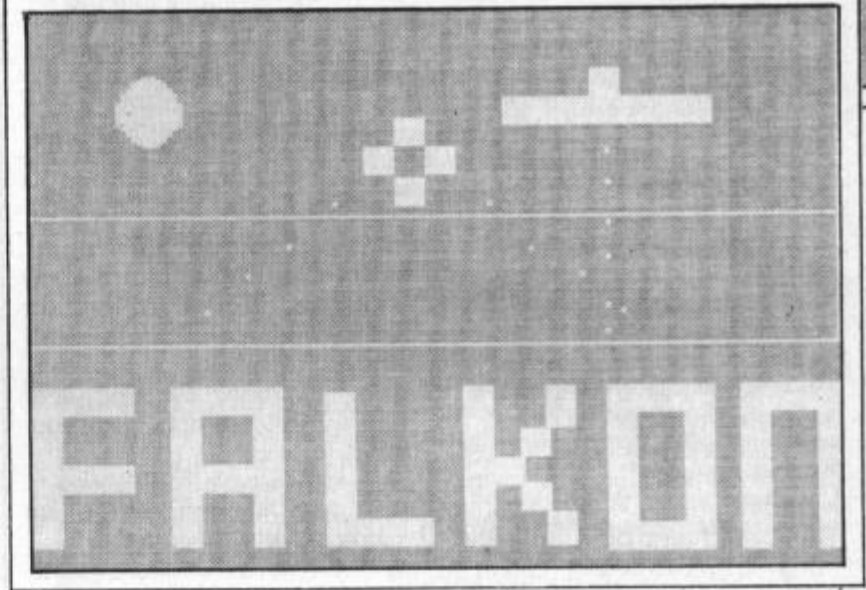
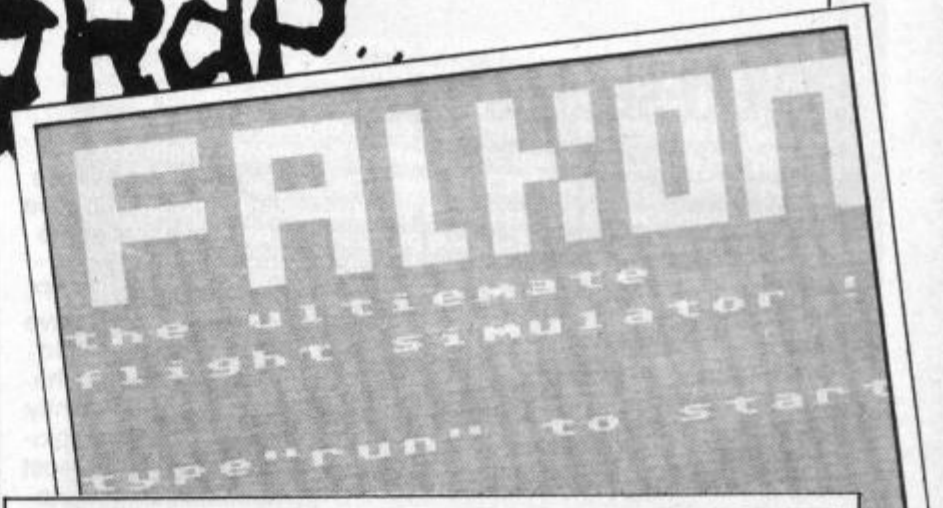

but his is simply because you are flying a top secret stealth fighter, which makes no sound!  
When first loaded you are presented with an excellent title screen, complete with a funky piece of one-channel music which lasts up to 5 seconds, before repeating itself!!!  
From then on it's just a matter of typing 'run' and choosing from the many complex options. Overall this is the most state of the art piece of software I have ever seen!!! Miss this and you'll miss the greatest piece of entertainment this century!  
The makers have told me that they will soon be releasing *Carrier Command*, *Starglider 2* and that weedy Amiga game, *Dungeon Master*! They will also soon be releasing CD ROM for the Texas TL 99! We live and hope!

**PRESENTATION 100%**  
It's just perfect!

**GRAPHICS 98%**  
The 3D effect is so realistic, it's hard to believe you're playing a computer game!

**SOUND 81%**  
No FX, but this adds to the atmosphere and the five seconds of music is great!

**HOOKABILITY 97%**  
Super fast action grabs you from the word go!

**LASTABILITY 99%**  
Only one plane to destroy but the fun of flying around is good enough to keep you playing for years!

**OVERALL 100%**  
My God!!! It's full of stars! (2001!)

Well what do you think? Do I get a job as a reviewer?

**LONG LIVE THE ORIC!**  
Yours sincerely,  
Simon 'Ace Programmer!' Bone, Channel Islands

*Thank you, Simon. I sincerely apologize for any offence given to owners of such a wonderful machine. Your honesty is truly amazing, and as for you getting a job as a reviewer... are you sure you didn't mean PR person?*  
LM

## A VERY SERIOUS ISSUE

Dear Lloyd,  
I am extremely disappointed that ZZAP! consistently fails to tackle the important computer issues.

When reviewing software, you should include a rating for 'loadability'. This will tell the reader about the loading qualities of a tape/disc. This piece of information would be invaluable - I certainly wouldn't buy lousy loaders no matter how good the piece of software hidden therein. I suspect that some companies deliberately produce tapes that use several goes at loading to boost their 'lastability' rating.

Next, you need a 'Destructability' rating. I have experienced problems in wreaking revenge on lousy loaders (some tapes squash in your hand while others are a hammer job - I keep Thor quite busy!).

Also, 'Biodegradability' is important - I have yet to find a truly 'Green' tape. I have dug quite a few in around my roses but they simply don't rot down.

I admit you have, on occasions, employed biodegradable reviewers - Ciaran Brennan composted quite quickly. However, I had less success with Julian Rignall - 12 months and 5

kg of Gamotta later, he still lies there smiling. Oh well, I suppose it just goes to prove that some are more rotten than others.

I also wonder whether ZZAP! will compost well. So far, I have been unable to bring myself to deposit my back copies on the compost heap, but I did recently get the opinion of a leading biochemist, who thought that most of the contents would rot quite quickly. He was less sure about the pages that carry Randy's picture - he has known composting microbes to shy away from such creatures. There is a simple remedy - include Randy in the next batch you send me and I will plant him next to Maff.

I realise you won't print this letter due to not wanting to alarm your readers about where spent reviewers are sent, but I thought I should warn you that I am unlikely to renew our 'Recycled Reviewers' contract unless you mend your ways.

**Howard Joseph, Maidstone**  
P.S. Jack Diamond rotted down inside 3 days.

*Sadly, I think we've already sent Randy to you. But whatever you do please keep ZZAP! safe!*

LM

## SHARP CUSTOMER?

Dear Lloyd,  
I am writing to ask if you know of any companies that make game programs that are SHARP compatible. I have had my SHARP Mz700 computer for nearly 3 years. I heard that Amiga was compatible with SHARP? I hope you have heard of the SHARP computer? The SHARP is not a very popular brand of computer. My computer is cassette loading, I have been thinking of buying a disc drive for it.

Most of my friends have got Commodore and Amstrads. I was wondering if you could give me any ideas on how to change a Commodore game so that it is able to play it on my computer. The Sharp computer has basically the same sort of graphics as the C64, all I want to really know is if you know where I can get a hold of some Sharp games?

Would you please reply in writing as I very rarely buy your magazine. I hope you can help me.  
Ben Morgan, Australia

*A Sharp Mz700? Isn't that a calculator? Uh, a quick call to Dr Franco Frey reveals all. The Mz700 is in fact a pre-Spectrum computer which uses the same processor, the Z80, as that machine. A machine only for techies, it's my sad duty to inform you that however rarely you buy ZZAP!, it's a lot more times than people write Mz700 programs. Still, there might be a museum willing to take it off your hands.*

LM

## A WHINGER WHINGES ABOUT WHINGERS

Dear Lloyd,  
I'm fed up reading the letters that are moaning about the 64's demise in the Rrap. Why don't you stop printing them as they all say the same thing and no one gives a dead elephant's fart about their whinging. You could use the space for more interesting letters. Doesn't it occur to the letter writers that it's not ZZAP!'s fault. The fault lies with programmers. Andrew Braybrook for one has said in a recent interview with another mag that he won't program any more 64 games because he's worried he might be left behind when the 64 goes. I congratulate programmers like Martin Walker because although I have no doubt he can code 16-bit machines, he is sticking with the 64 for the moment. Thanks Marty.

I'm not biased toward any machine as I own a 64 and Amiga but I think the writers of the moaning letters are jealous that they don't have or can't afford an Amiga, and to compensate for this they want to banish Amiga reviews so they are not reminded of what they are missing.

Anyway, I think most 64 games cuff their Amiga counterparts in one respect. Playability. Software companies seem to like dressing up Amiga games in fancy graphics and sonix and forgetting the gameplay bit. *Wizball* on the Amiga is the most blatant example. The 64 version gets my vote for the greatest game of all time but the Amiga is a cruddy ST (puke) port over and is totally unplayable due to the speed of the aliens, the slowness of Wiz and his slow firing rate.

Onto the diary now. I think the new diarist should be Martin Walker (enclosed is a crisp £100) as he is witty and can explain in detail his programming exploits. Or Sensible Software as their games show great humour.

Finally Rob H's score on Citadel is puny, my best to date is 118076 so start practicing if you want to beat that one Rob.

Colin Fulton, Scotland  
P.S. Sorry the £100 was only Monopoly money but I'm as skint as the rest of the ZZAP! team claim to be.

*What do you mean, Monopoly money? I used it to buy a CD Walkman off Mr Hogg - he did comment about new-fangled bank notes though: like most Newsfield employees, the most money he's ever seen is a ten shilling note!*

LM

## A TYPICAL LETTER

Dear Lloyd,  
You should be praising your bad luck, that I wasn't going to be nice to you and point my Solid Imagerising Particle Lazer into all ZZAP! readers homes, thus blessing you each with 11 million pounds worth of Boots and WH Smith software tokens. Luckily for you my S.I.P.L. transmitter had decided to blow up. Then I realised it did transmit, but the distance between me here at Alpha Centuri, and you at Earth, would make the beams expand four million times making the tokens four million times their size 'n' weight, destroying Earth in the process.

Back to reality . . .  
Every month at home I read my ZZAP! to all Alpha Centurions and this is what they have to say about it.

'Oui I lik dei poke part.'  
'Yes the reviews are really top class.'  
'Er 5 past 93.'  
'More on arcades.'  
'Hi, my name B James B a good read, more diaries'.  
Thank you guys now I have the Alpha Centurions' top 3.

1. KULT
2. VOYAGER
3. KRISTAL

Mew The 1,2,3. Cambridge (!?)

Ah yes, reality. I remember that.  
LM

Dear Lloyd

I have things, nose

And pantomime horses

at gunpoint. Give

me a software

Voucher or

they die

signed

The caped kidnapper  
(alias S. Leach)

The policy of this magazine is never to give in to terrorist threats, Mr Caped Kidnapper. Besides which your unusual thoughtfulness in providing a full address should mean you're now reading this in a police cell. Any other hoaxers are warned that next time it'll be a F-111 bombing raid with Robin 'Mad Bomber' Hogg at the controls!

LM

## NO COMPLAINTS (WELL JUST ONE!)

Dear Lloyd,  
I have always read ZZAP!, I have read it since issue one through to issue 53 and have had no complaints about the magazine. I now use the Amiga as my main computer. Below are a few things that I want other readers to read and take in.

1) In recent issues there have been many complaints from C64 owners on the coverage they get compared with all mighty Amiga. All those people can shut their mouths for once and open their eyes. The C64 is suffering from age and the amount of games for it have reduced by many. ZZAP! cannot just click their fingers for games, they have to be released before ZZAP! can review them.  
2) There was a letter in issue 53 from someone called Adam Zayani who after complaining about C64 coverage, moaned that he kept typing in Amiga pokes for his C64. I would like to say that if he can't tell the difference between C64 Basic and

Amiga Basic where has he been, the old C64 has never had commands like CALL in its basic and it never will.

3) The subscription offers should have at least one alternative for Amiga owners, I want to renew my subscription but I don't want freebies like Red Heat on cassette for the C64, I would like something like a ZZAP! T-Shirt or a ZZAP! Binder.

Andrew Finlayson, Blackpool

1) True. But this month its the C64 with two Gold Medals, and the Amiga lacking even a Sizzler (unless something new comes in after this was written). But as Xmas gets nearer it seems likely both machines will soon be deluged with software.

2) Basic? What's that?

3) Good point. Dr Franco has been contacted and he promises to do something for Amiga owners soonish, probably starting with this very issue!

LM

## WILL ZZAP CRASH? (II)

Wotcha Lloyd!

Welcome to another of my letters brought to you in glorious pink-o-vision TM. God this colour's awful (sound of person vomiting off-mike) Have you any idea how many sheets of paper have been utilised to bring you this epic? No? Well I'll tell you. Too many. Great eh? Better get to the point, Lloyd me ol' mate: is ZZAP! going the same way as CRASH magazine, i.e. being reduced to twenty or thirty pages with a cover mount cassette to make it worth the asking price, I hope not. I bet many people have noticed the ever shrinking syndrome affecting the mag and attributed it to the customary summer software slump. If it is, and you have less advertising revenue (meaning less pages), I'd be willing to pay more - up to £2.50 in fact - for a ZZAP! of about issue 43 thickness providing there were some decent features within. Oh and Lloyd, while we are on the subject of features, please think about printing a tips booklet (detailing all the tips info you have ever printed) again. You must have had at least three letters about it now. C'mon Lloyd get the fatties/thin people who work upstairs/downstairs to get going on one before I send ze boys round. I dunno about paying £10 for one though - would it really cost that much?

Y'know Lloyd me ol' china, I don't usually moan about things so I'd better make an exception now. The standard of game titles (to put it bluntly) is dire. Y'know game titles... the bits usually at the head of a review which tell you which game is being scrutinised? Capisco..? Sorry? ... DO YOU UNDERSTAND ME?.. IS THERE ANYONE THERE? There is? Oh goody, I thought I was going mad. Where were we? Oh yep. Game titles. Well Lloyd, me ol' bulb, I don't really think that scribble (as seen in the CITADEL and TIME SCANNER reviews in particular) is very professional. Honestly, I bet a four year old kid could do some of them. Why can't the art boffins (very talented I'm sure they are) use a standard font - how about the Roman style on the front of issue 53 instead? It would make the magazine more suited to the supposedly older 16-bit owners who read the mag (yes 16-bit owners are usually older. INTERESTING FACT NO. 1156. Don't ask me - I read it in TGM). Yes I know that all this font business is a little bit (or maybe a tad) petty. I'm not sure why I brought it up really. Oh well, think about it anyway.

Anyway Lloyd, young-fella-me-lad, I'd better toddle off now. I've got work to be doing - like a Citadel map (looks difficult at the moment but I'm having a go anyway - by the way, why didn't Citadel get a Gold Medal? It's the best thing on my C64 since Armalyte, and that got a GM). Wish me luck in my exams please!!! I get my results on August 24th. If I get nine 'A' grades will you remove that paper bag from your head and show your true identity? Have we got a deal? No I thought not. Ho hum...

Keep up the good work - the mag is completely hatstand. OII! MANGRAM NO DOZING OFF. I HAVEN'T FINISHED. I've got fifteen sheets of pink paper left. I don't suppose that any of the ZZAP! lads would be interested... ? OH MANGRAM. WHERE ARE YOU GOING? I'VE GOT MASSES TO GO YET. Fifteen tons of sprouts. Dozen eggs... Metal discovered in can of meatballs. Rant... drone... waffle.  
Will 'The Man' Callaghan, West Midlands  
P.S. The words F\*\*\*ing and P\*\*\*ed off are NOT funny and severely lower the tone of the mag.

Well, readers here's one of the advantages of being in the black-and-white part of the mag - no pink-o-vision. Feeling relieved? You should do. Now onto the CRASHing of ZZAP! I can't see it happening but it all depends on what you, the readers, want - we wouldn't want to upset you, would we?!

As for game titles being childish? Well, the art department is the art department, and sometimes they do go over the top. But to be fair when we reviewed Citadel the cover art hadn't been decided so there was little to work from. Standardized titles would be neater, but mightn't they be a bit dull? In any case the 'look' of ZZAP! is under constant review and could be changed soon!

On the subject of a Citadel GM, I've asked the team and while they still think it's a great game they don't believe it's quite that good. But the whole point of the forum is for readers to put their views forward, so if anyone else disagrees with any marks please write in. Try and explain why you think the team's wrong, and maybe other readers will be persuaded to look again at the game in question.

LM

# ZZAP! RRAP



## CORRUPTION IN ZZAP! TOWERS?!

Dear Lloyd,

A few issues back (No. 44 to be precise) you received a letter accusing ZZAP! of accepting bribes in return for good reviews. At the time I laughed and dismissed the letter as being written by someone trying to get their name into ZZAP! but now I'm beginning to see his point.

Let me give you a few examples. *LED Storm* for instance received a Sizzler yet when I played a copy (borrowed, thank God!) I found it utter crap with minimum playability. Also, *Barbarian II*, which received a Gold Medal, in my books did not deserve 80%, graphics being the only high mark justified.

I will admit almost all the Sizzlers, Gold Medals, and Silver Medals I've bought I have been extremely pleased with, but you're not going to take bribes for every game are you?

**Scott Leach, Hull**

P.S. Bring Rockford, Thingy, Nose and Panto Horse back – they're great! If not, at least give an explanation why they've gone.

*The ZZAP! reviewers say that the huge wedges of cash nestling in their secret Swiss bank accounts have had no effect on game ratings! But seriously, just because you disagree with the ZZAP! team about one or two games out of the many hundreds reviewed doesn't mean that the reviewers are taking bribes! Tastes in software, like anything else, differ. Indeed, even the reviewers can often be seen squabbling among themselves about ratings (ie pushing each other out of third storey windows). You have my assurance that the ZZAP! team would never take bribes, or in anyway be influenced by software houses.*

**LM**

*Unless I'm offered over £10,000, a Panda Turbo or a night out with Gail McKenna!*

**RH**

*Cor! I'd rather have a night in with Gail McKenna!*

**PK**

## PRAVDA? NYET!

Dear Lloyd,

We here in Russia must congratulate you on a beautiful new first issue of ZZAP! (what issue are you up to in England? No.5?) Due to our great and very fast transport system here in Russia we get things very quickly, see! I wrote this letter on the 19th September 1985 (with my brand spanking new 'BIRO' pen which cost 10 Roubles, £2 quid to you!) I will place a wager that my letter arrived within 5 days, this will be down to our new automated horse-drawn team service, good yes?!

I have just been to the local soft-shop and bought my brand spanking new copy of *Annihilator* and *3D Skramble* also, they only cost me £30 each (what value!).

Anyway, there is great news of new arcade games to come; they are such new releases as *Pac-Man* and *Space Invaders!* I have been warned by the arcade owner that we are to beware of Ninjas, he says they will multiply and dominate video games, though I cannot see people making games about such subjects as beating people up!!!

Now, I must go, I am going to watch the opening of a beautiful, brand spanking new Tractor factory. First though, I must keep the horse running or the electric will fade. I must also get our weekly rations of cabbage and spinach.

Demitri Igor Pollockoffabean, HAG!!!!

P.S. Must say 'yo!' to Cak, 'Ears' Nige, chubby Tusk, Donkey Cav, Bean-head, my goldfish, 'Ears' Bill and Cak's sea apple.

*It's always a great thrill to get letters from overseas readers such as yourself Demitri, I wish you many happy years of computer gaming and as for Raid Over Moscow, we utterly deplore it. Sorry your letter was a bit delayed but doubtless that was due to our own Post Office rather than yours!*

**LM**

## WANT TO SELL A C128?!

Dear Lloyd,

My next thing (some more I here you cry) is a question I hope you will be able to answer for me. I have heard a lot about the Commodore 128 computer recently about how good it is and I wanted to buy one. I rang up my local Commodore stockist and he said he couldn't get one. Then I tried ringing Commodore itself. A man said that they stopped making them and when I asked him if that meant I couldn't get one, he said yes and laughed. He said the only thing I could buy was another 64 or an Amiga which is out of my price range. Do you know of anywhere I could get one?

By the way I know this letter is a bit on the large size but I get carried away sometimes going on and on about really stupid and boring things without a full stop so it makes everyone trying to read my words of wisdom turn blue so by the time I have finished writing my totally useless paragraph they have all keeled over and died.

Another good question I would like to ask is how the Scandinavian oil shares are doing, are they going up or down waffle waffle gibber gibber (take him away I here you cry).

**David Freeman, Lancs**

*Gasp! Well David, Scandinavian oil shares are doing very well, which is more than can be said of the poor old C128. That you can't get them anymore is something of a blessing since the number of games which make any use of its superior hardware could be counted on the toes of a Blabgorian (the one-footed star of Gribbly's Day Out). But unless you're a huge fan of CRL's Rocky Horror Show (available from the Zzuperstore) the C128's only real advantage is its ability to run CP/M business software. Thousands of programs have been written in CP/M standard – it's the standard used for the PCW 8256 word processors for example, albeit for a different disk format. But you could buy an Amstrad PC for about the same price, and that has an even bigger, and more advanced business software range. So unless you're as daft as the Ed, who owns one of these sleek white elephants, I wouldn't bother when C64s are so much cheaper. As for the length of your letter, your points on piracy were well made last ish so I snipped them to save too many readers asphixiating!*

**LM**

## THE ONLY FEMALE READER?

Dear Lloyd,

HELP!!! Am I the only young lady with a computer and who also reads ZZAP!? I am a 19-year-old computer addict (I've got a Commodore 64), who has just 'splashed out' on a Citizen 120D printer and Commodore disk drive. I think ZZAP! is brilliant!

I use my computer most of the time for things such as playing games (*Grand Prix*'s my favourite), writing adventures and word processing. So, come on girls . . . if there's any more of you with computers, write in and prove that I'm not the only one!

**Stephanie Johnson, Harrow Weald, Middlesex**

*What do you mean the only female reader? Grandma Mangram's been reading ZZAP! ever since it came out! She just loves the knitting patterns (actually, Granny, I think they're listings! No wonder that last cardigan went a bit wrong!) and always laughs hysterically at the silly pictures of the reviewers.*

*Any more female readers out there? Well, do what Stephanie says and write in. And Robin would appreciate it if you send in some photos for his wall, even though he's just got a watch from a head-banger girlfriend with 'Rabid' inscribed on it! Goodness knows how he got that nickname, wink wink!*

**LM**

**Right, now that whacky lot have been locked safely away in padded cells (not the letter writers; the reviewers!) I'll toddle off home where Grandma is already in the process of knitting a special woolly bag to keep my bonce warm in the cold months ahead.**

**In the meantime if you've any comment to make on the Commodore scene (or anything else for that matter!) send it to LLOYD MANGRAM, ZZAP! RRAP, PO Box 10, Ludlow, Shropshire SY8 1DB.**



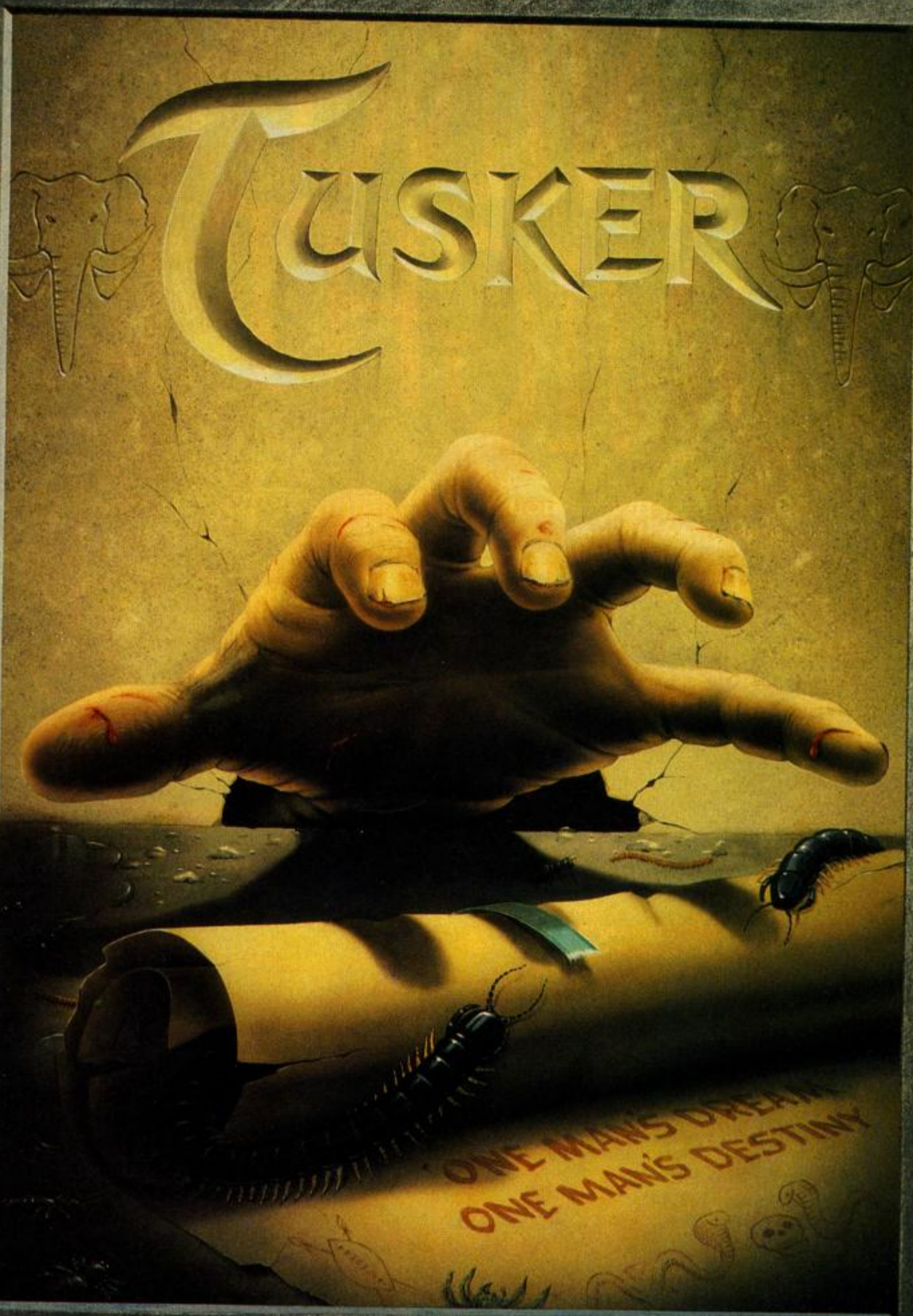

C.64



S Y S T E M · 3



AMIGA

SYSTEM 3 SOFTWARE, BLENHEIM HOUSE, 1 ASH HILL DRIVE, PINNER, MIDDLESEX HA5 2AG  
Telephone: 01 866 5692 FAX: 01 866 8584

AVAILABLE ON SPECTRUM, AMSTRAD CPC, C.64 AT £9.99. DISC £14.99  
AMIGA £24.99 ATARI ST £19.99

# BURNING THE MIDNIGHT OIL

Xmas '89 looks set to be awash with high octane fuel as the software houses rev up for a highly competitive race up the charts. First off the mark is Activision's *Powerdrift*, but coming up fast there's *Stunt Car Racer* (MicroProse), *Hard Drivin'* (Domark), *Chase HQ* (Ocean) and US Gold's super-secret *Turbo Out Run*. A surprise launch at the PC Show, the C64 version was entrusted to Probe Software.

**P**robe is a somewhat unusual in that it's more of a development house than a programming one. As run by Fergus McGovern, Probe 'co-ordinates projects' - overseeing the actual programmers who are usually freelancers on six month contracts. The majority of the *Turbo Out Run* project is being handled by Ice (a new Scottish development team), but the C64 game no-one wanted to attempt. When Probe were called they turned to Mark Kelly and Steve Crow,

the programming team which had just finished *Mr Heli*. But time was extremely tight . . .

How long did you have to do it?

**MK:** Sixteen weeks! Another programming house is doing all the other versions, but no-one wanted to do the C64 game until we stepped forward. After we took it on we spent a few days wandering round with upside down smiles. At first we thought we'd have to lose most of what was in the arcade game. This is the first racing game I've done and it involved a lot of original programming. Steve was really helpful, being a



programmer himself, and came up with most of the ideas for how to do it.

**SC:** You're far too modest!

What sort of hours were you working?

**MK:** I'd start programming at about nine in the morning, and work until ten or eleven at night.

**SC:** I work at home most of the time, four days there, two days at Probe, having just Sunday off. All the graphics were drawn on an ST, then transferred onto a PC to be put on the C64 via PDS.

You've written a lot of original hit games on your own, why did you stop?

**SC:** I got fed up with it. It was exhausting writing *Firelord*, so when Andrew Hewson phoned me about doing graphics for this Scottish programmer he had, I was really pleased.

When did you start writing games?

**SC:** At school. I even formed a company called Poppysoft with a friend who handled the

marketing. But when he left I let the company go, and went on to Bubble Bus where I wrote *Starquake* and *Wizard's Lair*. After that I did *Firelord* for Hewson.

When I met Mark he was working on *Marauder*, and I really enjoyed working with him. Concentrating mainly on the graphics is a lot less hassle, so I'm enjoying working on games again, and the industry's extremely exciting now.

Did you have the arcade machine to work from for *Turbo*?

**MK:** Yes, it's great. At first it seemed like a nightmare, it was so hard to play, but after all the games I've had on it now I can play straight through without any problems. We also had hundreds of pictures taken - practically every frame of the game was photographed for us to work from. US Gold even did a video for us.

**SC:** A lot of coin-ops have diagnostic features, allowing you to pause the game and output graphics, but not Sega machines. In fact Sega hardly gave us any help. Still, I really enjoyed this project. The

▼ The Ferrari enthusiasts responsible; Mark Kelly and Steve Crow (l-r).



arcade has very sharp, cartoonish graphics the spirit of which I've tried to replicate. I think a lot of people will try and copy the style we've come up with in this game.

The original *Out Run* wasn't too well received on the C64, did Probe have anything to do with it?

MK: No, if you look at our press releases you'll see we make a point of not mentioning that version. We did all the others, but that one was handled by some obscure company which I think soon went bust.

How would you describe the *Turbo* coin-op for people who haven't played it?

SC: Well, it's a race across America with lots of new features. There's a choice of automatic or manual gear change, and you can earn points for better grip, more speed and an improved turbo. The Ferrari F40's built-in turbo gives you super-speed, but if it overheats you're in trouble! And if you use it over an oil spill

▼ A quick spin in the countryside reveals Steve's fine detailing on the Ferrari F40.



the oil ignites. There's also lots of different landscapes, from snowy mountains to crowded cities to forests with logs on the road. And of course you have weather - rain, snow and sandstorms! All of this we're going to get into your C64!

How is the *Turbo* program being done?

MK: There are four loads, each with four levels, made up of 35K of graphics and 5K of music and sound FX. All the rest is data and source code. There's also a great intro sequence being programmed by Mark Hill, with 25K of music and sampled FX (including speech) from the Maniacs Of Noise. Each of the loads are going to be really fast, about 20 seconds, and there's also going to be five continue

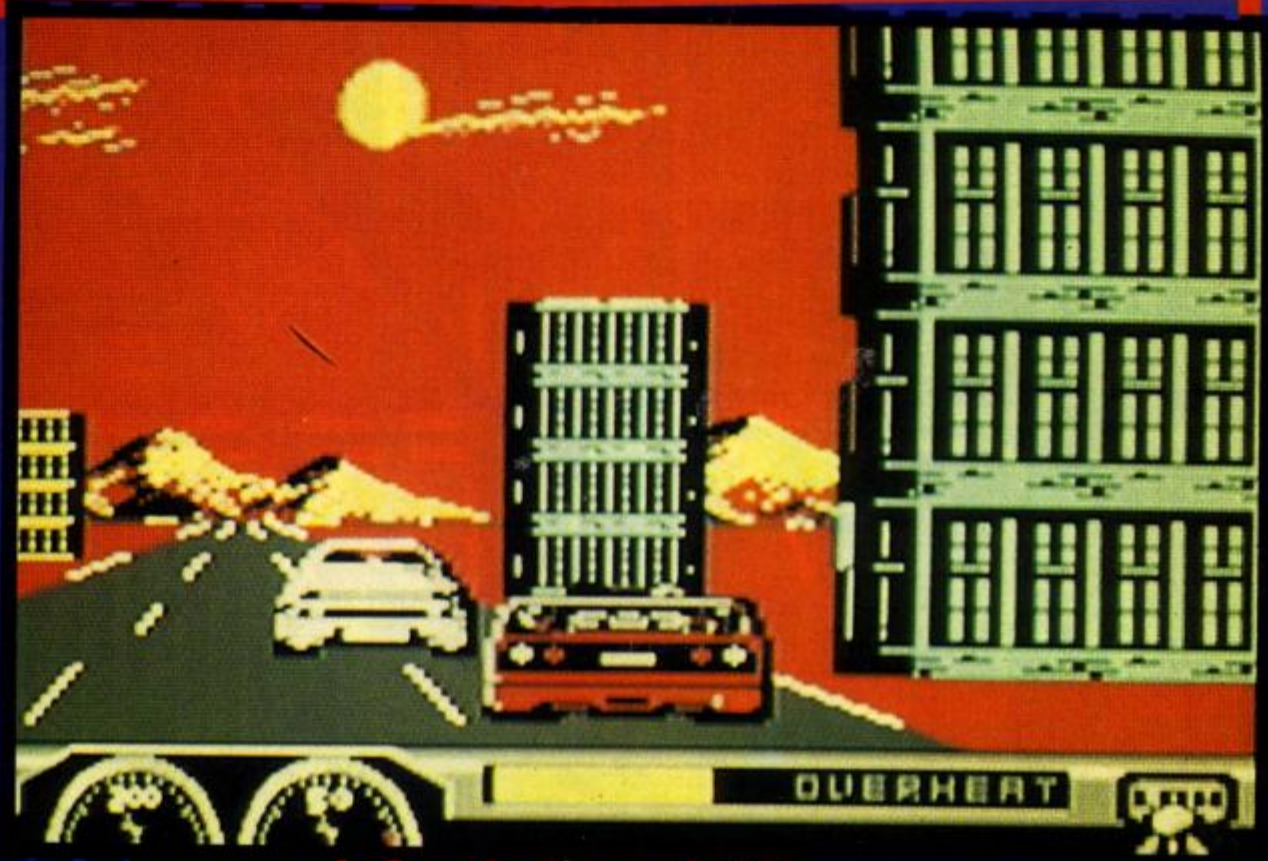

▲ Zooming through one of the four cities in *Turbo*

plays. So if you get to the final level of the last load and die, you're given an option to restart on the first level of the load. I really believe you have

What was the hardest part?

MK: The side graphics. There's hundreds of them in the coin-op and there's no way you could include all of them. We've tried to get most of them in though, and while at first we weren't going to do the bridges we've got them in now. And all the cars are in there, too. I really think this is going to be the best race game ever.

When did you start programming?

MK: Like Steve, I started at school. I went through a whole range of machines; a ZX81, PET, VIC 20 (which I did my first games on), a Spectrum, and a C64. Now I can program pretty much everything, including 16-bit and consoles. I was at college when I got my first game contract, that was to convert Irem's American football coin-op, *Ten Yard*

to give your all in programming, otherwise you're going to get eaten alive by the reviews.

▼ Stop the press! Who's that? - Debbie

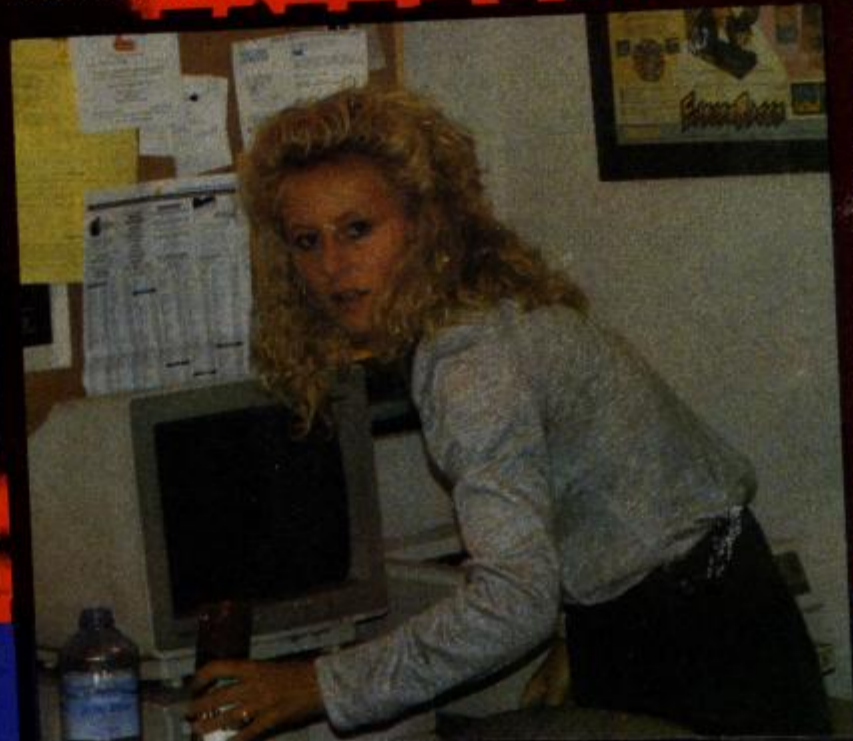

*Fight*, to the C64. It was a complete mess, with Elite supplying virtually nothing, and was eventually abandoned. After that I formed Arcanum Software Developments with some friends in Scotland, and sent out demo disks. Our first project was *Captain Courageous* for English Software, it was quite popular at the PC Show but was never released because I think the company went bust.

My next game was *Sophistry* for Hewson. This was based on *Zolyx*, and licensing disagreements with Firebird forced its cancellation. Anyway Hewson were quite good, letting me develop *Marauder* with Steve, although I would've liked a lot more time on it. By then the other members of Arcanum (Barry Leach, Alan MacFarlane, and Robert McGowan) wanted to go their own separate ways. Anyway, I soon picked up two freelance contracts, one from Probe for *Mr Heli* with Steve (who'd ended up at Probe as well, by coincidence) and another for Palace. The latter was *Crackdown*, another C64 conversion with Bob Stephenson doing the graphics. But the game we were converting from ran into troubles, so that project fell apart too. Obviously after all the hassle I've had, working at Probe for a good salary has been great. I get more now for a month's work than for some games I've written!

What will you be writing next?

MK: Well... it's going to an arcade conversion. That's about all I can say.

# MAZE MANIA



SPECTRUM  
CASSETTE 9.99

COMMODORE  
CASSETTE 9.99  
DISC 14.99

AMSTRAD  
CASSETTE 9.99  
DISC 14.99

## HEWSON

Flippo must travel through mazes of the upper plane, turning the titles as he goes. Avoiding gliding aliens that appear to hinder his quest.

Collect icons to gain extra power. Bound over star-spangled black-holes to avoid being suspended, forever lost in inner space.

For Mail Order send a cheque/P.O. to Hewson Consultants Ltd. Order by credit card by sending your Access/Barclaycard number, and enclose a specimen signature. Don't forget to enclose your name and address.

Hewson, Milton Park, Milton, Oxon. OX14 4RX Tel: (0235) 832939 Fax: (0235) 861039

As part of our continuing development of innovative Software we are always happy to evaluate software sent to us with a view to publication.

# GIVE IT SOME STICK!

A good joystick can make gamesplaying much more fun and help you achieve those record-breaking high scores. But a look around your local computer shop (or Dr Franco's ZZUPERSTORE!) reveals dozens of sticks to choose from, coming in all shapes and sizes, and for vastly dif-

ferent prices.

So by popular demand, and the odd death threat, mad joystick-basher PHIL KING puts the latest batch of new sticks through his extremely unscientific tests and rates them (four stars for the best).



## MEGABLASTER

Konix, £6.99

A joystick for less than seven quid – can it possibly be any good? Well for the small price it is suitably petite with a two-inch handle and two tiny fire buttons. The base is only about three inches square with rubber feet to aid stability on a tabletop, although the stick is more suited to handheld use. At the low price, instead of expensive microswitches there are the old-fashioned leaf switches for stick movement and fire buttons.

I tried the Megablaster out on that fab footie game *Kick Off* (well, any excuse to play my all-time fave game!). Playing against the computer at international level I struggled to a 2-1 win. Subtle moves inside the penalty area were particularly difficult – there are no satisfying clicks to help you get the correct direction. Diagonals are easy enough to obtain; perhaps too easy as I found it more difficult to get vertical and horizontal directions. I also had a few problems shooting with the fairly stiff fire buttons – especially awkward for handheld use.

Trying out a few other games, I had similar problems: basic directions are okay but when it comes to intricate movements the Megablaster just doesn't have the required accuracy. Still, for such a low price it's not as bad as I expected, although ultimately you get what you pay for.

Phil's Verdict: ★★ – Fairly good value for money.

## RACEMAKER

Euromax, £26.95

Crikey! It looks like someone's ripped this straight out of a jet cockpit (You didn't did you, Robin?). The twin handles have comfortable hand grips and a fire button either side. Sideways directions are achieved by rotating the handles while vertical movements are obtained by pushing/pulling. On the large, sturdy base there is a 'dial-a-speed' autofire knob, while underneath are four suckers for extra stability.

Obviously a stick of such specialist design won't be much good for most games – I tried playing *Kick Off* with it to hilarious result! So I decided to try the Racemaker out on that high-speed racing game, *Continental Circus*. A doddle – that's what I thought it would be with a brill, specially-designed steering wheel. But I was in for an unpleasant surprise. The Racemaker was so slow to respond to my movements (sometimes not at all) and with it being so stiff – no double entendres here please! – holding it forwards all the time soon made my (admittedly thin and extremely unmuscular) arms tired. In fact, steering was so awkward that I couldn't even qualify on the first circuit – normally a very easy task!

After trying the Racemaker out on several flight sims (torture! – they always bore me silly anyway) I was still unimpressed. Instead of providing movement proportional to how far you turn the wheel or push/pull, the Racemaker is in fact just a tarted up joystick with a switch for each direction!

Phil's Verdict: ★ – Terrible, and not really useful for anything (except maybe as an abstract sculpture or expensive doorstop!).



GIVE IT SOME STICK!

## CRYSTAL

Powerplay, £14.99 (Standard), £16.99 (Turbo – with autofire)

After the original, clear plastic joystick the Crystal now comes in all-red or all-green for fashion-conscious gamers! The stick features microswitches for the moulded handle and two square fire buttons. The Crystal Turbo also has an autofire switch, located at the bottom-right corner of the base.

Initially trying the Crystal out on *Kick Off* I found the moulded handgrip and concave fire buttons very comfortable and the responsiveness very good. But, with a fuming Ed peering over my shoulder, I decided it was time to play something else! So I took on the Ed at that old favourite, *World Series Baseball* (he was reviewing it for this month's budget section). I had no problems with either directions or firing and was soon 6-0 up, at which point the even more fuming Ed mysteriously disappeared!

The Crystal is a good all-rounder and suitable for all types of game. It's small enough for handheld use and the rubber suction cups make it perfect for the tabletop. My only gripe is the joystick handle – it's a bit on the thin side and the stick travel is surprisingly long. Other than this, the Crystal is a great stick, although I must

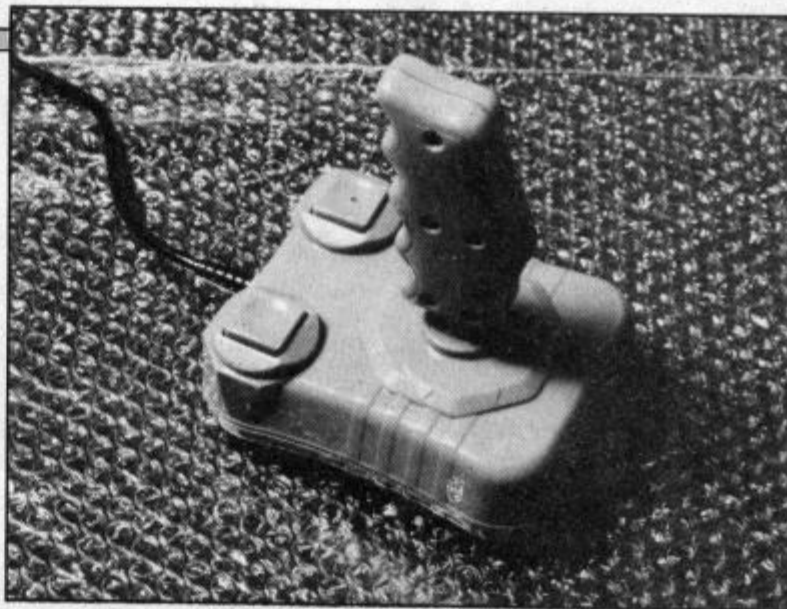

admit I prefer the chunkier Cruiser (also from Powerplay).

*Phil's Verdict:* ★★★ – Whichever colour you prefer it in, the Crystal's a fine stick, although perhaps a tad on the expensive side (two quid more than a Cruiser).

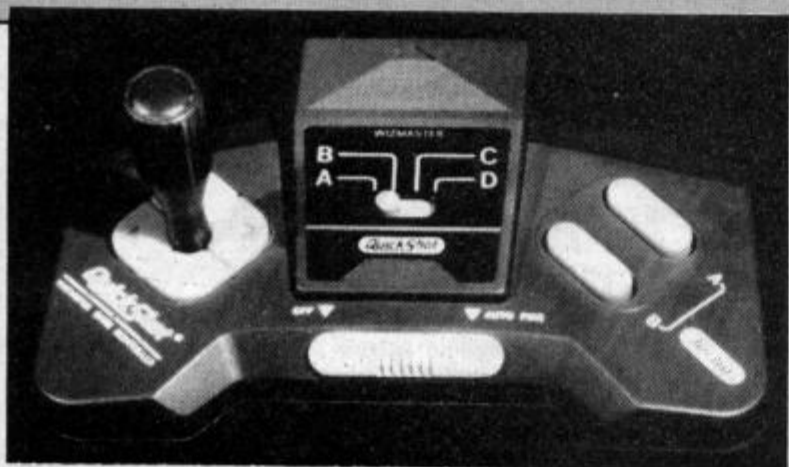

## QUICKSHOT WIZMASTER

Spectravideo, £11.95

This is novelty: a joystick which pulls apart! The Wizmaster consists of a multi-adaptor (with a switch for various consoles and computers) which plugs into the base controller. This allows you to interchange a number of different Quickshot bases – what a weird idea!

The controller itself is much like those given away with consoles, having a joypad into which you can screw either a small knob (no tittering please!) or a larger shaft (Don't you think that's enough innuendo? – Ed. (No! – Phil)). There are two small fire buttons (only one of which works on 64 and Amiga – the other one is for consoles only) and a large autofire switch. The base also has four removable rubber suction cups for tabletop play.

This sort of stick is very suitable for platform-type games (there are a lot of these on consoles!) so I tested it out first on *Indy: The Action Game*. I'm not normally very good at this game anyway, but to my surprise, the Wizmaster made it more difficult than usual. I had real trouble trying to get Indy to walk straight instead of jumping or crouching as, with its extremely short, clickless travel, the stick has a tendency to slip into the diagonal directions. It didn't matter which handle I tried it with – knob, shaft, or nothing at all – I found it equally difficult.

Worse still, I'm right-handed but the stick is on the left side of the controller with the fire buttons on the right – I would definitely have preferred it the other way round, although left-handers and arcade fans (where the same arrangement dominates) would like the present configuration.

Leaving Indy behind, I wanted to test the autofire function, so I loaded up the ideal game, *Xenon II*. The autofire proved to be very fast, and produced a long stream of bullets to bash the aliens.

With its tiny joypad and fire buttons, the Wizmaster is fiddly to use and inaccurate. I'd prefer a 'proper' joystick myself, though if you're left-handed and own a console this could be a VFM buy!

*Phil's Verdict:* ★★ – A bit fiddly to use, although console owners might like it.

## THE BEST OF THE REST

### CRUISER

(Powerplay, £12.99 Black or Clear Autofire)

★★★★ – The Cruiser is my favourite stick. The design is simple but brilliant: two large fire buttons inset into the rounded base, and a ball-type handle of just the right shape and size. It's very comfortable to use, extremely durable, and the microswitches make it ultra-responsive. My idea of the perfect stick.



### COMPETITION PRO 5000

(Dynamics, £13.50 Normal, £14.00 Clear, £15.00 Extra – rapid fire and slow motion)

★★★ – A classic design with two large fire buttons on the base and ball-type handle. The directions are micro-switched but unfortunately the fire buttons use less responsive leaf switches – the only flaw in an otherwise excellent stick.

### NAVIGATOR

(Konix, £14.99)

★★★ – A novel design rather like a Star Trek phaser – no wonder 'Trekkie' Ed likes it! You hold the Navigator like a gun with the very short handle on top and a trigger fire button on the 'gun handle'. Despite its weird shape it's surprisingly comfortable to hold and very responsive.



# SCORELORD



Phil 'The Footie' King has been assisting me this month, so don't be surprised to see loads of stupid soccer scores. But at least the footie-mad reviewers haven't managed to finish their new *Kick Off League* after I hid the disk in an economy-size bottle of Big Dom! They only found it when they went to clean the communal toilet - this is an annual event! In the meantime, loads of people have been asking for the return of the Scorelord Challenge. As soon as I've persuaded one of the lard-bellied ZZAP! slobs to get up off their extremely flabby backsides it might just happen - the electric nutcrackers should do the trick!

## 720° (US Gold)

793,880 Spiro Harvey, Wellington, New Zealand  
646,050 Phillip Davies, Pencoed, Mid Glam  
550,490 Daniel Briggs, Torrensville, S Australia

## ALIEN SYNDROME (Ace)

362,500 Bret 'Cool' Crossley, Rothwell, Leeds  
259,500 Martin Lindsay, Geraldton, Australia  
223,610 D Emmins, Stratford, London E15

## APB (Tengen)

49,655 (Day 10) Lenny, Warley, West Midlands

## ARKANOID II - REVENGE OF DOH (Imagine)

437,140 Keith David Boones, Shrewsbury, Salop  
411,690 Scorrano Hassime, Orbe, Switzerland  
276,250 Mark Smith, Broxbourne, Herts

## ARMALYTE (Thalamus)

59,672,200 Col & Grinny, Rochdale, Lancs  
35,477,900 Andrew Rawley, Billericay, Essex  
34,241,300 Philip Burns, Mackam, Sunderland

## BARBARIAN (Palace) (Amiga)

10500 Daniel Besser, Bletchley, Milton Keynes

## BARBARIAN II (Palace)

310,000 Lee Tanner, Basildon, Essex  
291,080 Neale Willis, Long Eaton, Notts  
289,000 John Turkeck, Carrickfergus, N Ireland

## BATTLE VALLEY (Rack-It)

1,990,775 Japmaster, Ettingshall Park, Wolverhampton  
1,986,700 Marc Spence, Leeds, W Yorks  
1,949,000 Darren Brookes, Long Eaton, Notts

## BIONIC COMMANDO (Go!)

1,352,820 Marc Spence, Leeds, W Yorks  
1,184,760 Wayne Fowler, Basildon, Essex  
1,150,620 A Barnett, Spenceley, Salop

## BLOOD MONEY (Psygnosis) (Amiga)

317,000 (Completed - Bloody Hell!) C Hall, Houghton-le-Spring, Tyne and Wear  
126,450 Christian Madsen, Denmark  
111,800 Stuart Wynne, ZZAP! Towers

## BUBBLE BOBBLE (Firebird)

8,692,430 Richard Pembroke, Wirral, Merseyside  
8,670,790 Anthony Melarangi, Runcorn, Cheshire  
8,215,420 Simon Bettison, Sheffield, S Yorks

## BUGGY BOY (Elite)

149,640 Robert Pascoe, Truro, Cornwall  
125,670 Daniel Moxey, Lowestoft, Suffolk  
124,690 Jonathan Dood, Parklands, Northampton

## CITADEL (Electric Dreams)

305,776 William Callaghan, Tipton, West Midlands  
181,250 Andrew Roberts, St. Helens, Merseyside  
161,176 Keith Hayes, Blackpool, Lancs

## CYBERNOID (Hewson)

135,875 Wayne Fowler, Basildon, Essex  
132,270 Dean 'SJT' James, West Bromwich, West Midlands  
124,800 Babak Fakhamzadeh, Delft, Holland

## DARK SIDE (Incentive)

6,130,726 Kuddly Bix, York, N Yorks  
5,860,626 Colin Fulton, Ayr, Scotland  
5,764,176 David Petyt, Wakefield, W Yorks

## DENARIS (US Gold/Rainbow Arts)

851,030 Bret 'Cool' Crossley, Rothwell, Leeds  
520,370 Richard Boulton, Swindon, Wilts  
486,890 Ulte Cant, Hartlepool, Cleveland

## DRILLER (Incentive)

3,498,450 Ged Keaveney, Huddersfield, W Yorks  
3,226,070 Kudly Bix, York, N Yorks  
2,063,760 Daniel Fisher, Chesterfield, Derbys

## DYNAMITE DUX (Activision) (Amiga)

191,710 Phil King, ZZAP! Towers

## FIRST STRIKE (Elite)

73,300 Rob H, ZZAP! Towers

## GRYZOR (Ocean)

2,802,200 Richard Lunn, Leeds, W Yorks  
1,253,300 Japmaster, Ettingshall Park, Wolverhampton  
892,700 David Pocock, S Croydon, Surrey

## HAWKEYE (Thalamus)

2,695,550 Zap Treeby, Brixham, Devon  
2,520,800 Kyle Aminoge, Peterborough, Cambs  
2,456,250 Casey Gallacher, Calcot, Reading

## HUNTER'S MOON (Thalamus)

704,350 Colin Fulton, Ayr, Scotland  
631,474 Richard Mellor, Cannock, Staffordshire  
623,550 Colin Fulton, Ayr, Scotland

## IMPOSSIBLE MISSION II (US Gold)

112,100 Ian Taylor, Wollongong, Australia  
109,700 Neil Head, Stourbridge, W Mids  
108,600 Peter Srodecki, Dunstable, Beds

## INTERNATIONAL KARATE+ (System 3)

565,100 Martin Smith, Ashbrooke, Sunderland  
543,300 John Farrow, Barrowford, Lancs  
511,900 Katamati, Hounslow, Middlesex

## INTERNATIONAL KARATE- (System 3) (Amiga)

95700 Daniel Besser, Bletchley, Milton Keynes

## KICK OFF (Anco) (Amiga)

10 players sent off in a match - Chris Foote, Worcester Park, Surrey  
1st in International League - Stuart 'The Real Footie King', Didcot, Oxon

## MICROPROSE SOCCER (MicroProse)

(Teams beaten in Microprose Challenge)  
16 Stuart 'The Real Footie King' Major, Didcot, Oxon  
16 Paul Wheatley (PAZ!), South Norwood, London  
16 Matthew Carter, Camden, London

## MORPHEUS (Rainbird)

3,672,130 Paul Woods, Wallasey, Merseyside  
2,081,590 Lenny, Warley, West Midlands  
1,321,485 Richard Pembroke, Wirral, Merseyside

## NEBULUS (Hewson)

216,830 Dennis Watts, Hatfield, Herts  
201,240 Matthew Moriarty, Hurst Green, E Sussex  
166,370 Edward JD Jackson, Leeds, W Yorks

## NEW ZEALAND STORY (Ocean) (Amiga)

Level 3-3 (364,527) Stuart W, ZZAP! Towers  
Level 2-4 (130,788) Rob H, ZZAP! Towers

## OUT RUN (US Gold)

95,842,240 Martin Lear, Huddersfield, W Yorks  
92,128,800 Mark Crossthwaite, Stockport, Cheshire  
87,720,606 Julian Hare, Hampton, Middx

## POPULOUS (Electronic Arts) (Amiga)

154,450 Daniel Besser, Bletchley, Milton Keynes

## PROJECT STEALTH FIGHTER (Microprose)

518,970 JA Moore, Margaret River, W Australia  
127,250 Sue Barlow, Guisley, W Yorks  
91,230 Gijsbert Griffioen, Lelystad, Holland

## QUEDEX (Thalamus)

1010 Craig Archer, Victoria, Australia  
999 Steve Pratt, Leighton Buzzard, Beds  
949 Martin Huisent, Numansdorf, Holland

## ROBOCOP (Ocean) (Amiga)

353,280 (Completed) Rob(jocop) H, ZZAP! Towers  
352,580 (Completed) Chris Foote, Worcester Park, Surrey

## R-TYPE (Electric Dreams) (Amiga)

180,400 (Completed) Rob H, ZZAP! Towers

## SALAMANDER (Imagine)

341,695 Simon 'Ace' Poets, Dromore, Co Down  
255,100 Daren Burke, Romford, Essex  
247,005 Gaspart Arnaud, Belgium

## SAMURAI WARRIOR (Firebird)

3,850 Bret 'Cool' Crossley, Rothwell, Leeds  
1,827 Wayne Fowler, Basildon, Essex  
1,445 Tim Haines, Basildon, Essex

## SILKWORM (Virgin)

1,072,600 Gaspart Arnaud, Belgium  
812,500 Dean 'SJT' James, West Bromwich, West Midlands

## SLAP FIGHT (Imagine)

803,425 Vilya Harvey, Perth, Australia  
800,950 Shawn Sutton, Southampton, Hants  
756,450 Richard Ramsay, Gilmerton, Edinburgh

## STAR PAWS (Software Projects)

848,223 Roy Masson, Worthing, West Sussex  
693,378 Kriss, Northolt, Middlesex  
647,226 Martin Smith, Warrington, Cheshire

## STRIDER (Capcom)

42,250 Rob H, ZZAP! Towers

## TARGET RENEGADE (Imagine)

440,226 A Barnett, Spenceley, Salop  
436,700 Bret Crossley, Leeds, W Yorks  
426,700 Neil Maudling, Whitehaven, Cumbria

## TEST DRIVE 2 (Accolade) (Amiga)

186,730 (Completed) Maarten Boomsma, Groningen, Holland  
170,951 (Completed) Phil King, ZZAP! Towers  
152,577 (Completed) Randy, ZZAP! Towers

## TETRIS (Mirrorsoft)

131,029 J Tillotson, Halifax, W Yorks  
78,986 Stuart Scattergood, Deeside, Clwyd  
75,545 Steven Leary, Chelsea, London

## THING BOUNCES BACK (Gremlin Graphics)

8,875,496 Tim Smith, Nr. Nantwich, Cheshire  
3,949,835 Casey Gallacher, Calcot, Reading  
3,769,925 Alan Wescombe, Swindon, Wilts

## THUNDERCATS (Elite)

3,046,150 Robert Kisby, Horncastle, Lincs  
2,640,600 Steven Alexander, Cullybackey, Ballymena  
2,639,700 Warwick Hunt, Huddersfield, W Yorks

## URIDIUM+ (Hewson)

575,005 Tim Goldee, No Fixed Abode  
478,025 Neville Lewis, Port Talbot, S Wales  
335,350 Wessel Joubert, Belfast, RSA

## WICKED (Electric Dreams) (Amiga)

7 Constellations completed Rob H, ZZAP! Towers

## ZENJI (Firebird)

84,253 Lisa O'Halloran, Victoria, Australia  
66,250 Mark Crossthwaite, Stockport, Cheshire  
40,225 Mike Gillings, Portsmouth, Hants

## ZOLYX (Firebird)

605,681 Edward Yu, Raynes Park, London  
524,318 Rob Housley, Thamesmead, London  
377,413 M Blaser, Cheadle, Cheshire

## ZYBEX (Zeppelin)

445,150 Ged Keaveney, Huddersfield, W Yorks  
398,950 Steve Lee, Guildford, Surrey  
397,950 Marios Stylianides, London, SW16

## ZYNAPS (Hewson)

1,093,200 Michael Collins, Castle Rea, Co Roscommon  
396,850 Steve Lee, Guildford, Surrey  
288,500 John Farrow, Barrowford, Lancs

## SCORE OF THE MONTH

FIENDISH FREDDY - completed with about \$13,000 by Phil 'Red Nose' King

## ZZAP vs TGM KICK OFF LEAGUE II LATEST RESULTS

USSR (Dominic Handy - TGM) 11 Played, 28 Points  
WEST GERMANY (Phil King - ZZAP!) 11 Played, 21 Points  
ITALY (Computer Player) 11 Played, 20 Points  
ENGLAND (Stuart Wynne - ZZAP!) 10 Played 13 Points  
FRANCE (Computer Player) 11 Played, 12 Points  
HOLLAND (Robin Candy - TGM) 10 Played, 11 Points  
ARGENTINA (Warren Lapworth - TGM) 10 Played, 10 Points  
BRAZIL (Mark Caswell - TGM) 10 Played, 1 Point (Snigger!)

(Bah! That Mr Handy's definitely got the best team (the Russians run so fast they must all be on steroids!) while Phil and Stu have been lumbered with painfully slow teams. Still, at least the rest of the TGM crew aren't doing too well!)



# POWER CARTRIDGE

FOR YOUR COMMODORE

64/128

SO MUCH FOR SO LITTLE

TRIED AND TESTED - OVER 100,000 SOLD IN EUROPE

AVAILABLE FROM ALL GOOD COMPUTER RETAILERS

YOU WILL WONDER HOW YOU EVER MANAGED WITHOUT IT

TRADE AND EXPORT ENQUIRIES WELCOME

42 Page manual



- \* POWER TOOLKIT
- \* POWER MONITOR
- \* TAPE & DISK TURBO
- \* PRINTERTOOL
- \* POWER RESET
- \* TOTAL BACKUP



A special KCS switching technique allows a program to be stored completely outside the memory of your Commodore 64/128. Using this system KCS developed the POWER CARTRIDGE. The 16K Cartridge, 100% machine code, gives the user an ideal extension to his normal computer.

## POWER TOOLKIT

A powerful BASIC-Toolkit (Additional helpful commands) that considerably simplifies programming and debugging.

AUTO	HARDCAT	RENUMBER
AUDIO	HARDCOPY	REPEAT
COLOR	HEXS	SAFE
DEEK	INFO	TRACE
DELETE	KEY	UNNEW
DOKE	PAUSE	QUIT
DUMP	PLIST	MONITOR
FIND	ILOAD	BLOAD

**RENUMBER** : Also modifies all the GOTO's GOSUB's etc. Allows part of a program to be renumbered or displaced.

**PSET** : Set up of printer type.

**HARDCAT** : Prints out Directory.

The toolkit commands can be used in your programs.

## DISK TOOL

Using POWER CARTRIDGE you can load up to 6 times faster from disk. The Disk commands can be used in your own programs.

DLOAD	DVERIFY	DIR
DSAVE	MERGE	DEVICE
DISK		

**MERGE** : Two BASIC programs can be merged into one.

**DISK** : With DISK you can send commands directly to your disk.

## TAPE TOOL

Using POWER CARTRIDGE you can work up to 10 times faster with your data recorder. The Tape commands can be used in your own programs.

LOAD	SAVE	VERIFY
MERGE	AUDIO	

## POWERMON

A powerful machine language monitor that is readily available and leaves all of your Commodore memory available for programming. Also works in BASIC-ROM, KERNAL and I/O areas.

A ASSEMBLE	I INTERPRET	S SAVE
C COMPARE	J JUMP	T TRANSFER
D DIS-	L LOAD	V VERIFY
ASSEMBLE	M MEMORY	W WALK
F FILL	P PRINT	X EXIT
G GO	R REGISTER	S DIRECTORY
H HUNT		DOS Commands

## PRINTERTOOL

The POWER CARTRIDGE contains a very effective Printer-Interface, that self detects if a printer is connected to the Serial Bus or User-Port. It will print all Commodore characters on Epson and compatible printers. The printer-interface has a variety of set-up possibilities. It can produce HARDCOPY of screens not only on Serial

printers (MPS801, 802, 803 etc) but also on Centronic printers (EPSON, STAR, CITIZEN, PANASONIC, etc). The HARDCOPY function automatically distinguishes between HIRES and LORES. Multi-colour graphics are converted into shades of grey. The PSET functions allow you to decide on Large/Small and Normal/Inverse printing. The printer PSET functions are:

**PSET 0** - Self detection Serial/Centronics.  
**PSET 1** - EPSON mode only.  
**PSET 2** - SMITH-CORONA mode only.  
**PSET 3** - Turns the printing 90 degrees!!  
**PSET 4** - HARDCOPY setting for MPS802/1526.

**PSET B** - Bit-image mode.  
**PSET C** - Setting Lower/Upper case and sending Control Codes.  
**PSET T** - All characters are printed in an unmodified state.  
**PSET U** - Runs a Serial printer and leaves the User-port available.  
**PSET Sx** - Sets the Secondary address for HARDCOPY with Serial Bus.  
**PSET L1** - Adds a line-feed, CHR5 (10), after every line.  
**PSET L0** - Switches PSET L1 off.

## POWER RESET



On the back of the POWER CARTRIDGE there is a Reset Button. Pressing this button makes a SPECIAL MENU appear on the screen. This function will work with any programme.

**CONTINUE** - Allows you to return to your program.  
 - Return to BASIC.  
**BASIC RESET** - Normal RESET.  
**TOTAL BACKUP DISK** - Saves the contents of the memory onto a Disk. The program can be reloaded later with BLOAD followed by CONTINUE. +

**RESET ALL TOTAL BACKUP TAPE** - RESET of any program.  
 - As BACKUP DISK but to TAPE.

**HARDCOPY** - At any moment, prints out a Hardcopy of the screen. Using CONTINUE afterwards you can return to the program.

**MONITOR** - Takes you into the Machine language Monitor.

... it's dynamite!

**WARNING:** Supply of the power cartridge does not imply any licence or right to use it for unauthorised copying of copyright materials

# BDL

Bitcon Devices Ltd

88 BEWICK ROAD  
 GATESHEAD  
 TYNE AND WEAR  
 NE8 1RS  
 ENGLAND

Tel: 091 490 1975 and 4901919 Fax 091 4901918  
 To order: Access/Visa welcome. — Cheques or P/O payable to BDL  
 Price: £14.99 incl. VAT  
 UK orders add £1.20 post/pack total-£16.19 incl. VAT  
 Europe orders add £1.50. Overseas add £2.50  
 SATISFACTION GUARANTEED. RETURN WITHIN 10 DAYS IF NOT FULLY SATISFIED

# MAD!

COM AMIGA



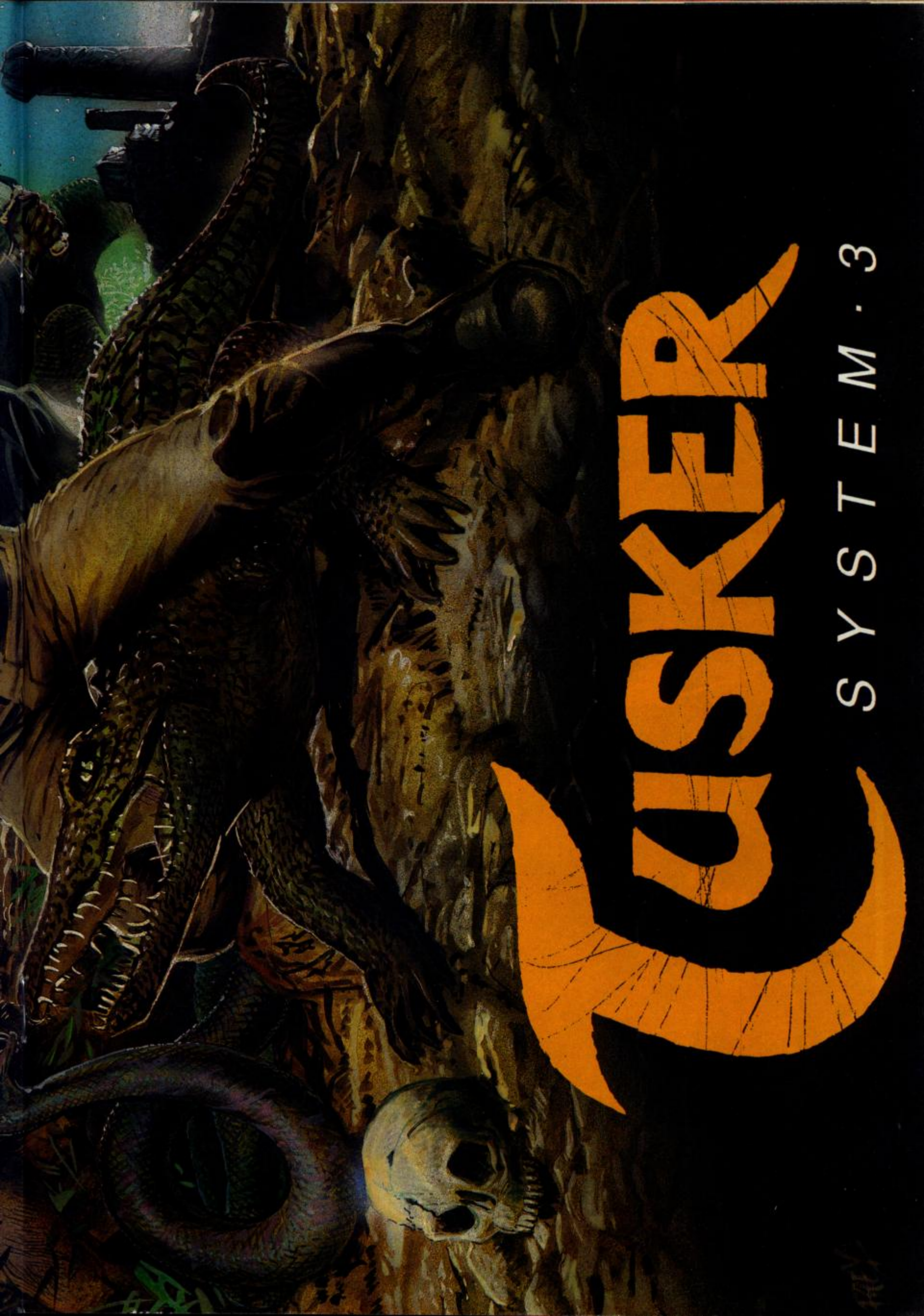

# CUSKER

S Y S T E M · 3

# THALAMUS

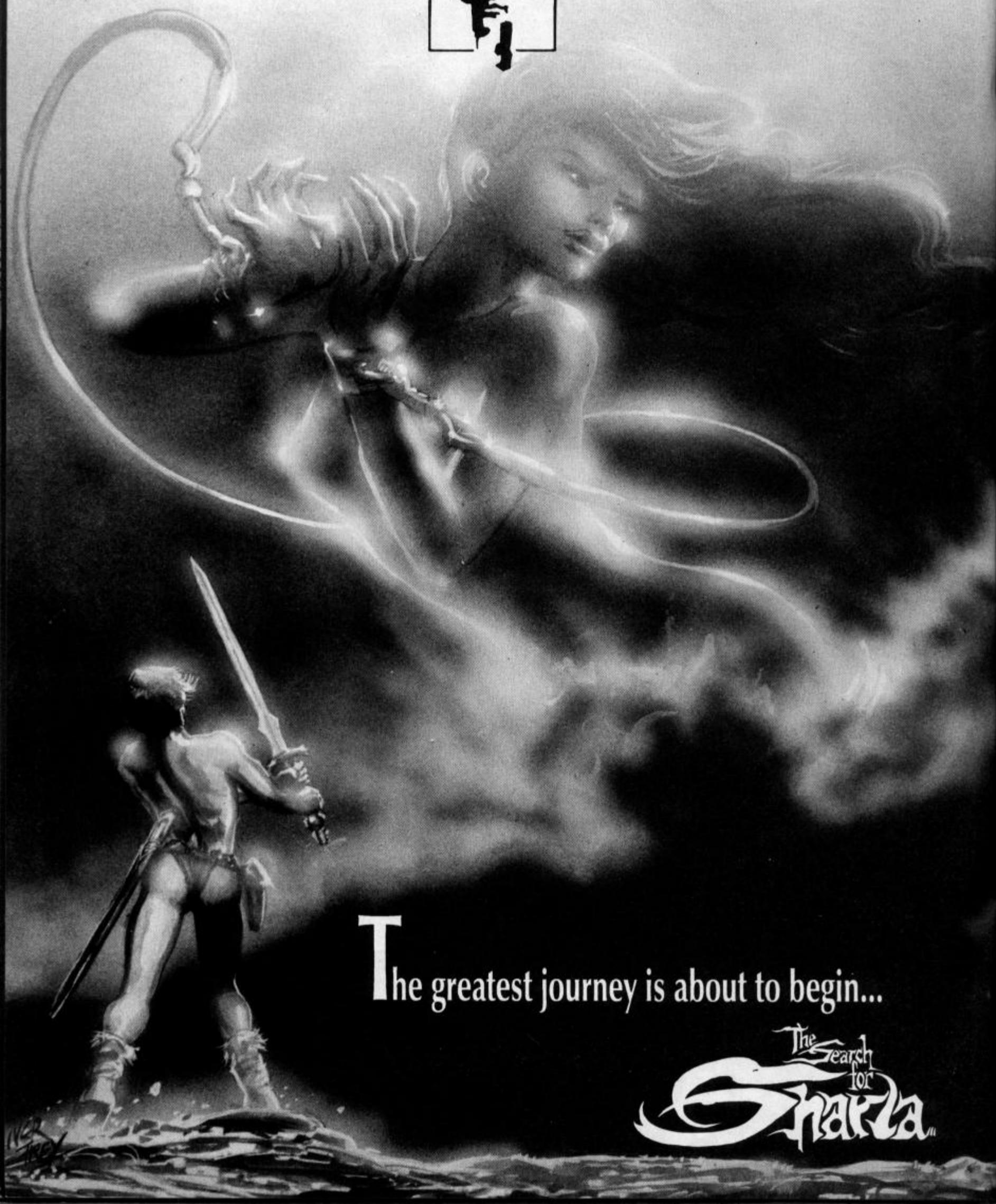

The greatest journey is about to begin...

The Search for  
**Shakti**

GO TO THE TOP

# RING UP! RING UP! IT'S DA GREAT COMPUNET GIVEAWAY!



Modems-a-plenty are waiting to give to YOU (Part Three – It's Your Last Chance)!!!

*It's all change for Part Three of our great Compunet promotion. This time, instead of drawing us a silly piccy, all you have to do is ring up our special competition hotline on*

**0898 555 081**

*Once again you can win one of FIVE C64 modems, complete with a three-month Gold subscription, giving immediate access to the best of the 'Net!*

*Send your entries to I'LL SHOW YOU WHAT TO DO WIV YER ?!\*\$??! FREE MOD-EMS COMP II, ZZAP! Towers, PO Box 10, Ludlow, Shropshire, SY8 1DB.*

*Usual competition rules apply and all entries must be in by October 23, so what are you waiting for? Get dialling!*

## TOP OF THE CODS

Hey tune into that groovy beat! I'm Kenno Brookes, and on tonight's show we have Curiosity Killed The Catfish, Sole II Sole, and Cliff Pilchard with his new single, 'I just don't have the halibut!'

But if you don't dig the music then why not ring me on

**0898 555085**

and find out all the latest about the mysterious goings-on in the ZZAP! Towers aquarium. I'll also give you yet another of my special yummy recipes to try out at home, so have a pencil and paper handy!

*(Calls are charged at 25 per minute off-peak (6pm-8am weekdays, plus weekends and Bank Holidays) and 38p per minute at all other times.*



# classifieds

## WANTED

**Wanted:** Action Replay cartridge MkIV or V. Will pay up to £27 for Mk V or pay up to £22 for Mk IV. Hurry! Write to:- H. Fu, 59 Baden Powell Road, Chesterfield, Derbyshire.

**Ghosts 'n' Goblins**, will pay up to £9 for a copy in good condition. Phone (04867) 88592 after 6.30pm and ask for Richard or write to: 27 Elder Road, Bisley, Surrey GU24 9HB.

**Wanted** Action Replay Enhancement disk C64 one that covers 90 titles. Pay price of disk if works in good condition. Tel: 0582 872565 or 240 Dunstable Road, Studham, Beds. LU6 2QJ, ask for Neil Sherriff. New drive.

## FOR SALE

**C64**, Basic, cassette deck, Basic, dustcover, manuals, £720 of original software, only £100. Many back issues of Zzap! Tel: 01 421 1559 after 5pm Monday to Thursday. Ask for Marc. Will not split.

**C64 tape games** from only 35p each! Lots of original new titles plus some real classics! For lists send SSAE to:- Andy Harris, 37 Mansell Road, Wisbech, Cambs. PE13 2SP or ring Andy on (0945) 582744.

**CBM 64**, 1541C, C2N, Freeze Machine, 2 Euromax joysticks. Ring 0565 52602 for details after 6pm. Serious offers only. Worth £500. Will sell for less.

**Want to have your own intro/demo** for £5? For more info write to: Bas, J.V. Campenlin 49, 2321 GB Leiden, Holland. Tel: (0) 71 762857.

**I crunch/protect** all your games. For more info write to: Bas, J.V. Campenlin 49, 2312 GB, Leiden, Holland. Tel: (0) 762857.

**C64**, colour monitor, 135 games, power pack, cassette recorder, two joysticks, six computer books. Call (0932 87) 2795 after 6pm. £375 ono.

**Sega Master system**, light phaser with games, Sega joysticks, all still boxed, good condition, worth £170. Sell for £85. Phone 0442 42436.

**CBM64**, C2N, over £500 worth of software including Last Ninja II, IK, Bionic Commando, Platoon, Ikari Warriors, Music Maker, Reset cartridge. Worth £810. Will sell £210 ono. Phone 644 2232 (Surrey), ask for Andy.

**Sega Master system**, good condition, 2 control sticks, 12 games, light gun and rapid fire unit. Worth £426, sell for £280. Phone: 0252 875525. Games include Vigilante, Time Soldiers, Shinobi, Space Harrier, Thunder Blade.

**C64**, tape deck (C2N), printer MPS 801, complete input programming course, 52ish, joystick and over £200 worth of software inc. Elite, Mini Office 2, Armalyte etc. All £200 ono. Ring (0394) 273380. Ask for Robert. Real bargain!

**C128**, OC-118 disk drive, datacassette, joystick, Expert cartridge, GEOS, blank disks, original games worth £200 and magazines worth £50. All boxed, condition as new. £375 ono. Phone Barnsley (0226) 723140 after 6pm. Ask for Curtis. HURRY!

**CBM 64**, joystick, tape deck, mouse and cheese, £800 worth of software inc. Operation Wolf, Driller, Last Ninja 1 and 2, World Games. Will sell for £200 ono. Ring Watford 223993 after 6pm.

**C64c**, Excelsior, 2 tape decks, 2 printers, 70 disks, mouse, 2 joysticks, Action Replay, magazines, software. All for £350. Phone 01 427 7853.

**Commodore 64c** with Oceanic OC-118 disk drive, AMX mouse, Action Replay Mk V Professional cartridge, cassette player and software including Hits, Gunship, Project Stealth Fighter. Worth £530, selling for £390. Phone Lee Brett (0933) 58684.

**Commodore 64c**, one year old, includes over 400 games, two tape decks and back up board, joystick, reset switch. Sell for £300 ono. Write to Jason, 1 Louise Croft, Druids Heath, Birmingham B14 5NY. NOW!

**Amiga users!!** Bargains for sale! Photon Paint, still packaged, £30, Spritz £15, Powerdrone only £10! Unwanted gift, hardly played. Send cheque or PO to D Sharpe, 45 Nottingham Rd, Cropwell Bishop, Notts. NG12 3BP - and HURRY!

**C64**, 1541 disk drive, datasette, joystick, powerpack, all leads, £200 of software (disk and tape), various manuals, blank disks, communications modem, plus mags. Offers welcome. Contact Nick on 01 764 2824 after 6pm.

**C128**, disk drive, 2 tape decks, joystick, approx. 250 games, Bombuzal, Dragon Ninja, etc., mags. £350, all manuals. Phone 0268 727183 after 4pm, ask for Guy.

**Check this out . . .** A sophisticated text adventure game for sale. Send an SAE to T.R.O.D., 1 Cornwallis Avenue, Edmonton, N9 OJH, London, or 48 Hazelwood Road, Enfield, Middx. EN1 1JQ for more info. So send now!!!

**C64**, good condition, C2N, joysticks, mags and books, around £1000 worth of software including Emlyn Hughes, Microprose Soccer and Salamander. Will sell for £250. Interested? Phone (01) 452 5592 after 6pm.

**C64 disks** for sale, over 1000 titles inc. Forgotten Worlds, Hawkeye, Barbarian 2 and much more. Write to Jack Tripper, 38 Glenville Ave, Clonsilla, Dublin 15, Ireland for a full price list.

**GENERALS**. A strategy game for the Commodore 64, only £2.50 for cassette. Send cheque

or postal order to 44 Princess Crescent, Pentwyn, Crumlin, Newport, Gwent NP1 4JG or ring 0495 215750.

**UNBEATABLE**. Commodore 64, CUB colour monitor, 1541 disk drive, datasette, Freeze Frame MK4, White Lightning compiler, over £600 of games, joystick, speech synthesiser, Zzap! magazines. Worth over £1150, sell for £400 (negotiable). Phone Richard (0737) 359424.

**C64**, 1541 disk drive, data cassette, Replay Mk 4, thermal printer, 400 games including Forgotten Worlds, Xybots, Indiana Jones (all on disk), loads of mags, joystick, disk box. All for £300 ono. Phone Willenhall 608457.

**WOW!** CBM64 games for sale. Prices from £0.50 to £3.00. Send a SAE to J. Allen, 39 Middlegate Field Drive, Whitwell, Worksop, Notts. S80 4NF. Games include Star Trek, Predator, Gryzor, Hardball.

**Commodore 64**, Oceanic disk drive, C2N, 2 joysticks, Freeze Machine, backup board and £320 worth of games including Last Ninja, Microprose Soccer and SEUCK. All for £280. Please ring 0749 73448 and ask for Dominic.

**Great games** for sale. All originals. Send SAE for list to Sean Miller, 19 Aultone Way, Carshalton, Surrey SM5 2LQ. Games include Armalyte, Dan Dare, Thing on a Spring and many more.

**Get your TAPE** games here! Look at these bargains. All games £3 or less!! Examples: Renegade III, Silkworm, LED Storm, Tracksuit Manager. Write to me stamp: H.Fu, 59 Baden Powell Road, Chesterfield, Derbyshire.

**Commodore DPS1101** daisy wheel printer, as new, also Commodore modem for 64 or 128 compatible with Compunet and Prestel. £200 for everything or £150 the printer and £60 for the modem. Phone James: Sevenoaks 454531.

**CBM 64c** (recently serviced), disk drive, C2N, over 70 games on tape and disk, joystick, Expert cartridge, blank disks, mouse, cheese, disk box and disk notcher. £400 ono. Phone Dave on 0475 30324 after 6pm.

**C64**, 1541, C2N, printer, modem, power cartridge, mouse, light pen, 50 disks, games and business software, keyboard overlay and more. £300. Phone (0752) 674468.

**CBM64**, disk drive, C2N tape deck and colour monitor. Many tapes, disks, books and ICPUG mags. £300. Phone 01 579 9097 evenings.

**Offer of the century!** C64, disk drive, printer, cassette, joystick, £600 of games inc. Dragon Ninja. Cost over £1200, yours for only £340 ono. Ring Jamie on (0742) 552797, Nether Edge Road, Sheffield. BUY NOW!!



# Official Secrets

for people who want more £22.00

**Confidential** 32-page A4 bi-monthly glossy magazine

VALUE £12.00

Confidential is written for people who take their fun seriously. If you are into Adventure, Strategy, FRPs, MUGs, PBMs, D&Ds, or if you would simply like to see more from behind the scenes then Confidential is essential reading. Regular features include Personnel File, Dead Letters, The Man in Black, Feature Articles, Brain Teasers, Diary, News, Competitions, and The Boss Upstairs. Club participation is welcomed.

**Gnome Ranger** or a surprise alternative!

VALUE £19.95

Gnome Ranger is an award-winning 3-part adventure by Level 9. "Go out and buy Gnome Ranger pronto" said Atari ST User. Or tick the box for Surprise Alternative.

**Myth** A mini-adventure by Magnetic Scrolls, authors of *The Pawn*

VALUE £15.00

Written exclusively for members of Official Secrets and, amazingly enough, included in the price of membership. Set in Ancient Greece, you play the part of a young god striving to prove himself worthy of immortality. You'll meet the Ferryman, have a chance to cheat Death, and do battle against the nine-headed Hydra guarding the gates to the Underworld. *Myth* includes the state-of-the-art Magnetic Scrolls parser and those incredible graphics. For most computers - disk only. Only to members of Official Secrets.

**Special Reserve** Included in the membership fee

VALUE £5.00

All the features and benefits of Special Reserve membership. See below.

**Help-Line** Manned each week-day and Sundays

VALUE £5.00

Advice and hints to help you solve most adventure games.

Join *Official Secrets* for a year. Membership includes 6 issues of *Confidential*, *Gnome Ranger*, *Myth* and *Special Reserve*, worth a total of £56.95. And you can save much more on the games you buy. All for just **£22**



MYTH WAS AWARDED A 91% CRASH SMASH BY CRASH MAGAZINE AND WAS RATED 85% BY THE GAMES MACHINE

## Special Reserve

best games at best prices £5.00

**Er - and the best service**

**Club Privileges** All club members benefit from our low prices and:

All the best games, carefully selected and available to members only at truly extraordinary prices. We're miles cheaper than elsewhere. Below are a selection of offers at prices you might not believe. You can buy games at the same time as joining - or join now and select from our catalogue of over 1000 products. There is no obligation to buy anything. All items advertised are only available to members and are subject to availability.

- Bi-monthly Buyer's Guide each with details of 40 games, building to a valued reference.
- Membership card with privilege number, and folder for the Buyer's Guides.
- 24-hour despatch of stock items. Over 700 lines in stock.
- Each game sent individually by 1st class post. Most will fit through your letter-box.
- 7-day sales hotline, open until 8pm weekdays, 10 to 5.30 Saturdays, 11 to 5 Sundays.
- Written notification and instant refunds on request in the event of unexpected delays.
- No commitment, no obligation to buy anything and no "minimum purchase".

### Miscellaneous

**AMIGA 500 complete**  
with PHILIPS 8833  
COLOUR MONITOR  
**559.99**

**AMIGA 512K RAM UPGRADE 129.99**  
GENUINE ITEM WITH CLOCK  
**MONITOR STAND 19.99**  
FITS OVER AMIGA OR ATARI ST  
**TWO PLAYER LEAD 8.99**  
FOR POPULOUS OR FALCON (NULL MODEM)  
**DUNGEON MASTER SOLUTION BOOK 2.50**

### AMIGA UTILITIES

KIND WORDS 2.0 (WORD PROCESSOR) 31.49  
PHOTON PAINT 10.99  
PROTEXT WORD PROCESSOR 64.99  
PUBLISHERS CHOICE (1 MEG) 66.49  
WORKBENCH 1.3 13.49

**SONY 3.5" DS/DD DISKS 79p**

### Amiga

BARBARIAN 2 (PSYGN)	15.49	LORDS OF RISING SUN	18.49
BEACH VOLLEY	15.99	MICROPROSE SOCCER	15.99
BLOOD MONEY	15.49	MILLENILUM 2.2	16.49
BLOODWYCH	15.49	NIGEL MANSELL'S G.P.	4.99
DEFNDR OF THE CROWN	8.49	PAELAND	7.49
DRAGON'S LAIR (1 MEG)	28.49	PACMANIA	8.49
DUNGN MASTER (1 MEG)	15.49	PERSONAL NIGHTMARE	18.49
DUNGN MASTER EDITOR	7.49	PHANTOM FIGHTER	4.99
DYNAMITE DUX	16.49	POPULOUS	16.49
ELITE	13.49	POPUL PROMISED LANDS	7.99
F-16 COMBAT PILOT	15.99	POWERDROME	16.47
F16 FALCON	18.49	PRECIOUS METAL	15.49
F16 FALCON MISSION	12.99	PURPLE SATURN DAY	8.49
FERRARI FORMULA 1	16.47	R-TYPE	9.99
FISH!	15.49	RICK DANGEROUS	15.49
FLIGHT SIMULATOR 2	25.49	ROBOCOP	15.49
FOOTBALL MANAGER 2	8.49	ROCKET RANGER	9.99
FM 2 EXPANSION KIT	6.49	RUNNING MAN	7.49
GEMINI WING	12.49	SHADOW OF THE BEAST	21.49
GOLD RUSH!	11.49	SHADOWGATE	9.49
GRAND PRIX CIRCUIT	16.49	SHINOBI	12.99
GUILD OF THIEVES	15.49	S.E.U.C.K.	18.49
GUNSHIP	15.99	SIM CITY	17.49
HELLFIRE ATTACK	4.99	STRIKE FORCE HARRIER	5.49
HOSTAGES	8.49	STUNT CAR	15.99
HYBRIS	11.49	SWORD OF SODAN	13.99
INDIANA JONES (ACTION)	13.99	TEENAGE QUEEN	8.49
JOURNEY	19.49	TETRIS	5.49
KARTING GRAND PRIX	4.49	THE NEW ZEALAND STORY	15.99
KICK OFF	12.99	THREE STOOGES	8.49
KING OF CHICAGO	8.49	THUNDERBIRDS	8.49
KRISTAL	9.99	TIME BANDIT	6.49
KULT	12.49	TRIAD VOL 2	15.49
LAST NINJA 2	16.49	TRIAD VOL 1	9.49
LEATHERNECKS	6.49	TV SPORTS FOOTBALL	17.99
LEISURE SUIT LARRY 2	19.49	VIXEN	3.49
LOMBARD RAC RALLY	14.49	WAR IN MIDDLE EARTH	14.99
		WATERFLOO	15.99
		WAYNE GRETZKY HOCKEY	17.49
		W/F ROGER RABBIT (1 MEG)	9.49
		XENON II, MEGABLAST	15.49

### Commodore 64 disk

3D POOL	9.99	FISH!	12.49
A.P.B.	9.49	FOOTBALL MANAGER 2	8.49
AAARGH!	9.99	FM 2 EXPANSION KIT	6.49
AFTERBURNER	8.99	FORGOTTEN WORLDS	10.49
AMERICAN INDOOR SOCCER	10.49	GEMINI WING	9.49
BARBARIAN 2 (PALACE)	9.99	GILBERT, FROM DRILL	10.99
BARDS TALE 1	5.99	GOTHIC	3.49
BARDS TALE 2	11.97	GRAND MONSTER SLAM	8.99
BARDS TALE 3	11.97	GRAND PRIX CIRCUIT	10.49
BASKETBALL	9.99	GUILD OF THIEVES	12.49
BATMAN CAPED CRUSADER	8.99	HEATWAVE	10.99
BATMAN THE MOVIE	10.49	HELLFIRE ATTACK	3.49
BATTLETECH	10.49	HEROES OF THE LANCE	13.49
BEACH VOLLEY	10.99	HILLSFAR	13.49
BLACK LAMP	4.49	INDIANA JONES (ACTION)	10.49
BLOOD MONEY	8.49	INDIANA JONES (ADV)	10.49
BLOODWYCH	8.99	INT KARATE	9.99
CABAL	10.49	JINXTER	12.49
CAPTAIN BLOOD	6.49	KICK OFF	9.99
CARRIER COMMAND	9.99	KNIGHT ORC	6.49
CHESSMASTER 2100	10.49	LAZER SQUAD	9.99
CITADEL	9.99	LEADERBOARD PAR 4	12.49
CORRUPTION	12.49	LEONARDO	10.99
CRAZY CARS 2	9.49	MAGNETRON	3.49
CURSE OF AZURE BOND	16.49	MICKEY MOUSE	9.99
DARK FORCE	12.99	MICROPROSE SOCCER	12.49
DEFENDER OF THE CROWN	9.99	MIGHT & MAGIC	11.49
DEJA VU	6.49	MOONMIST	5.49
DENARIS	10.49	MR HELI	10.49
DNA WARRIOR	9.99	OPERATION WOLF	9.99
DOMINATOR	9.99	PAELAND	6.49
DRAGON NINJA	9.99	PACMANIA	6.49
DRAGON SPIRIT	9.99	PASSING SHOT	9.49
DYNAMITE DUX	9.99	PAUL GASGOINE SOCCER	9.49
EYE OF HORUS	9.99	PAWN	12.49
FAERY TALE	7.49	PHOBIA	8.99
FIRE POWER	10.49	POOL OF RADIANCE	16.49
		POWER DRIFT	9.99
		QUARTERBACK	9.49
		R-TYPE	10.49
		RAINBOW WARRIOR	10.49
		REAL GHOSTBUSTERS	9.99
		RED HEAT	10.49
		RENEGADE 3	10.49
		RICK DANGEROUS	9.99
		ROBOCOP	10.49
		ROCKET RANGER	12.49
		RUNNING MAN	7.49
		SCRABBLE DE LUXE	10.49
		SHINOBI	9.49
		SILICON DREAMS	6.49
		SIM CITY	9.49
		SPEEDBALL	8.99
		SPHERICAL	8.99
		STAR WARS	4.49
		STARGLIDER	5.49
		STORM ACROSS EUROPE	16.99
		STORMLORD	9.49
		STUNT CAR	9.99
		SUPER QUINJET	9.49
		SUPREME CHALLENGE	
		(INCLUDES ELITE)	10.99
		TESTDRIVE 2 - THE DUEL	11.99
		TETRIS	3.49
		THE NEW ZEALAND STORY	10.99
		3 STOOGES (ONEMAWARE)	4.49
		THUNDERBIRDS	9.49
		TIMES OF LORE	9.47
		TIMESCANNER	9.99
		ULTIMA IV	13.47
		ULTIMA V	15.49
		VIGILANTE	10.49
		VIXEN	1.99
		WAR IN MIDDLE EARTH	12.49
		WEIRD DREAMS	10.49
		XENON	6.99
		XENOPHOBE	10.49
		XYBOTS	9.99

To order please write, or complete the coupon, or telephone us on **0279 600204**. Please note that there is a surcharge of 50p per game for orders placed by telephone.

### Order Form

Name \_\_\_\_\_  
Address \_\_\_\_\_

Post Code \_\_\_\_\_ Phone No. \_\_\_\_\_  
Computer \_\_\_\_\_ \*5.25"/\*3.5"/\*3.0"/\*TAPE  
Payable to: **Special Reserve or Official Secrets**

**P.O. Box 847, Harlow, CM21 9PH**

Special Reserve and Official Secrets are trading names of Inter-Mediates Ltd.  
Reg. Office: 2 South Block, The Maltings, Sawbridgeworth, Herts CM21 9PG.  
Registered in England Number 2054713. VAT reg. no. 424 8532 51

Special Reserve membership £5 UK, £6 EEC or £7 World

Official Secrets membership £22 UK, £25 EEC or £30 World

with Gnome Ranger and Myth  or with Surprise Alternative and Myth

Item \_\_\_\_\_ ZZAP £ \_\_\_\_\_

Item \_\_\_\_\_ £ \_\_\_\_\_

Item \_\_\_\_\_ TOTAL £ \_\_\_\_\_

Credit card expiry date \_\_\_\_\_ Overseas orders must be paid by credit card

\*CHEQUE/\*POSTAL ORDER/\*ACCESS/\*VISA

(Including Connect, Mastercard and Eurocard)

\* Delete where applicable

Prices include UK Postage and Packing

EEC orders please add 70p per item

World orders please add £1.50 per item



# Car Blimey!

## THE BUDGET BIT!

### COSMIC PIRATE

Byte Back, £2.99

In a galaxy far, far away there was born a young boy promptly burdened with the name Hilary Leslie Lovejoy. After a rather troubled childhood Hilary swiftly changed his name to Guy Manly and went off to be a terribly butch, and well 'ard space pirate. Crime isn't what it was though, and in the future it's extremely well organized with a Council regulating your actions. Before you can even leave the space station you must achieve an accuracy of 40% plus in one of the simulations. The first three simulations are free, with wireframe spaceships attacking you across a multi-directional scrolling background. Other simulations, such as Disasteroids (**Asteroids**), cost money to try out. Once you've

proven your shooting skills you're offered a selection of missions – to begin with you can only attempt a mission with an 'A' code. A mission starts with you being warped out to a map grid. The truck you're going to loot is represented by a fish icon, and you move toward it square by square. Green squares require a toll – shoot the aliens and pick up their cash – while black ones don't. There are also planet squares and pirate squares to explore. In each square a white box appears which shows the direction you must fly in. Once you get back to base you can splurge your cash on new weapons (ie Sony Cutter) and shield units (ie Tesco Supal) besides paying for boring stuff like launch tax

and new missions. With so many different missions the save/load facility is very useful. People with a fairly good memory should remember the Amiga version scoring 87% last April, so why the C64 game has moved from Outlaw to new budget house Byte Back is a bit of a mystery. Apart from the absence of the truck battle scene, gameplay is virtually identical. Presentation is also remarkably similar,

with colourful planet graphics and good enemy ships. In retrospect the Amiga game was a bit over-rated. Despite all the flash add-on bits gameplay is not that much more than multi-directional blasting, but it's still very playable. Compared to the chronic simplicity of most budget releases this is a welcome surprise, and highly recommended.

**OVERALL 85%**



### PITSTOP II

Kixx, £2.99 (Rerelease)

Five years old and facing tough competition from such brand new, full price releases as **Continental Circus** and **Test Drive II**, obviously this Epyx release is looking really dated, isn't it? Nope, not at all. In my opinion this is still the best racing sim around on any computer. It's principal advantage is the superb two-player mode, using the split-screen to give real head-to-head competition. But even in one player mode (in which the computer drives the other screen car in a full ten car field) **Pitstop II** is superb, with good graphics and superb sound – the engine roar is terrific, indicating speed so you don't need to look at the mph. As you'd expect there's a choice of six different race tracks, from Brands Hatch to Vallunga in Italy, with a Grand Circuit option where you play each in turn to win points to

be World Driving Champion. There's also a choice of three, six or nine laps and three difficulty levels. The main effect of a harder difficulty level is to worsen tyre damage. Each tyre starts off black but collisions with

other cars, and the side of the track, change a strip of colour on the tyre to indicate damage. After the strip turns yellow, beware! – the next collision will blow the tyre, sending you flying off the road and out of the race. In two player mode, one particularly sadistic tactic is to bump into your opponent's most vulnerable tyre!

On each circuit there's a brief strip of track which you can move into for a pitstop. The view then switches to the pits, with two mechanics to change tyres and refuel the car. Fast pitstops can be the key to the game, so be quick! But the best tactic is to avoid them, by taking care of your tyres and watching fuel consumption (which increases with speed!). But the unique feature of **Pitstop II** is cramp! Even at amateur level you're always struggling for position, leading to pain on the scale of a **Decathlon** game! But no gain without pain, as they say. **Pitstop II** is simply one of the best games you can get for your C64!

**OVERALL 96%**



## WIZBALL

Hit Squad, £2.99 (Rerelease)



**W**izworld was once famous as the most beautiful and colourful place in the universe, a world so pretty not even the Prince of Wales could moan about its architecture. But then came the evil Zark, whose hideous henchmen drained the world of all its colour. Only the Wiz, and his faithful cat Nifta, can restore the world to its former glory.

To ready himself for combat the Wiz shrinks down into a ball, initially capable of only bouncing left or right and firing. But after collecting some pearls, one being deposited after a wave of aliens have been destroyed, the Wizball can be customized. As pearls are collected icons are lit up above the screen, waggle the joystick and the icon is activated. To start with anti-grav removes gravity allowing free movement, then more powerful weapons such as multi-directional firepower and a smart bomb can be added.

And then there's Nifta, also in a ball, which can either follow behind the wizball firing or, when fire is held down, be moved around by the joystick. Nifta is vital as he's the only one who can collect the drops of colour deposited when colour bubbles are shot.

Once fully armed you have to collect red, green and blue drops to restore colour to a level. There are also black drops (making everything go dark), blue drops (causing a 'Filth Raid' with six ships swiftly attacking) and purple drops sending the cat insane. These are all too easy to pick up in the heat of battle!

Wizworld comprises eight levels, stacked vertically with connecting holes and tunnels, and each either a red, blue or green bubbles - forcing

you to move between them if you're to get enough of each to restore colour on a level. Once you do restore colour there's a bonus level where all the aliens attack you. Lives can't be lost here; only gained if you shoot enough aliens. When you finish this level there's a neat animated display of Wiz mixing the colours in a cauldron.

And if any of this sounds a bit too complex, don't worry! there's a simple solution - buy the game! After a few goes everything becomes obvi-



ous, though never easy, and totally addictive. One of the most original games ever written, it's also among the best shoot-'em-ups ever to grace home computers. The graphics are good, the sound is incredible with a brilliant intro tune

and superb spot FX, but the main thing is the great playability. Once you get into **Wizball** there's no getting out. Quite simply one of the compulsory purchases for any self-respecting C64 owner!

**OVERALL 97%**



## CRYSTAL CASTLES

Kixx, £2.99 (Rerelease)

**B**entley may well be a bear, but in this coin-op conversion his first love is gems, not honey. Eighteen Crystal Castles have floors covered with gems, but Bentley's not the only one eager to fill his pockets. Mad Marbles like collecting them, and will try and catch you if you move in on their patch. Tree Spirits are no less hostile, but if you jump over them they're temporarily frozen. Skeletons move at random, while Gem Eaters actually eat the diamonds - run over them as they swallow and they're destroyed. But Berthilda the witch can only be killed if you wear a magic hat. Don't take too long though or a swarm of bees appear to chase you around.

Bonus points can be won by collecting the honey pot, the hat and the last gem on any screen - rather than letting the baddies gobble it. The Castles are divided in three loads, six per load. Once you complete the game it goes back to the start, only faster. If you want to start off fast, you can select one of four speed levels, as well as a 'take it in turns' two-player mode.

Basically this is a 3-D Pac-Man game complete with lifts, ramps, tunnels and hidden passages. The C64 version replicates the coin-op's shimmering castles with great graphic flair. The small screenshots on the back of the inlay look like coin-op pictures, and close up the

game is still quite impressive. Sound is equally good, with the blips of picking up gems being very musical.

While this is an ancient coin-op, the **Pac-man** concept still has a lot of strength in it (look at **Pac-mania** on the Amiga) and this is one of the

best versions around. Although repetitive and initially difficult to control, using diagonals, this is simple, uncomplicated fun which is well worth buying on budget.

**OVERALL 65%**



## KENDO WARRIOR

Byte Back, £2.99

And what does Ken D Fish do when he's not poring over your results? He changes into a super secret agent armed only with a special Kendo Sword. But simply wandering around Ludlow High Street with a ninja sword and face mask might seem a bit silly. Much more sensible is breaking into the offices of EMAP to steal job application forms from the heavily guarded safe. Needless to say the offices are patrolled by ruthless ninjas and vicious attack dogs. A swift bit of swordplay might suffice to despatch them, but brain power is needed to get past obstacles such as a broken gas pipe spewing flames. To help you such objects as a 3 amp fuse (!) and a pipe wrench may be picked up. Also of use are bulging sacs which give you special energy to get past 'particle beam doors'. Once you get the special forms you have to reach the roof, to be lifted off by helicopter.

In short then, this is a flick-scrolling arcade-adventure beat-'em-up. There aren't that many puzzles—the main challenge is mapping and combat—but it's all very well done. The backgrounds are very nicely detailed and the sprites aren't bad

either. An atmospheric tune further adds to the attractiveness of the game, making a top-notch budget release. Clearly with this and **Cosmic Pirate** Byte Back have kicked

off with a spectacular bang, if they keep this up they could easily become the best budget label around!

**OVERALL 82%**



## SOLDIER OF LIGHT

RAD, £2.99 (Rerelease)

Galactic High Command want to clear the galaxy of Federation infiltrators, but being an exceptionally stingy bunch they're coughing up the cash for just one soldier to wipe out the hordes. Of course, it's you and there are three planets to be cleaned up. These planets can be attempted in any order, and each consists of you stomping or leaping rightwards, collecting more powerful weapons, and all the time blasting soldiers, low-flying spaceships and an end-of-level super-tough enemy.

While the baddies on each world are pretty much the same, backgrounds vary with a moon-like planet, a plant world, and an Egyptian planet. All these are crammed into a

single load, and if you complete one you have to fly to the next planet—this is a horizontally-scrolling shoot-'em-up section which adds a nice bit of variety.

Simplistic coin-ops like **Soldier** often make the best conversions, but sadly this isn't the case here. Graphics are okay and sound mediocre, but the main problem is the relentless attack of the enemies. However many you shoot there's always more, and the man is awkward to move fast enough to give you a fair chance. Still, if you think you're up to challenge this is good value for money on budget and well worth a look.

**OVERALL 64%**

## WORLD SERIES BASEBALL

Hit Squad, £2.99 (Rerelease)

This was one of the first titles from the new Imagine, the label set up when Ocean bought the name from the famous, but defunct Liverpool company. It was a spectacular debut, perfectly demonstrating the C64's colourful and musical advantages over the old Speccy.

After the cheerleaders have waved their poms poms about, one player stands to bat while the other (or the computer) pitches. The big stadium TV screen shows a close-up of the ball's flight, allowing the pitcher to control the ball and the batter to time his swing (or refrain from swinging if he thinks the pitch is a 'ball' (the baseball equivalent of a no ball)). If the pitch is good and isn't struck it counts as a 'strike': three strikes and the batter's out.

Hit the ball (forward of the foul lines) and you automatically run to first base, and further manually if you think you can make it. For the

pitcher, control is switched to the fielder nearest the ball, who must try and throw the ball to one of the bases before a runner gets there. Further complications are added by the ability to 'steal' bases, when runners can attempt to make it to the next base while the ball isn't near them.

Once three batters have been sent back to the dug-out, the other side has their turn batting. After nine goes each, the team with the highest number of runs wins. It's all very easy to pick up, but tough to win—especially against someone who pitches like Phil 'Screwball' King. While **Hardball** offers a more realistic game, **WSB** remains as much fun now as when it was first released. Highly recommended, and good preparation for seeing all the new baseball movies coming out now.

**OVERALL 78%**

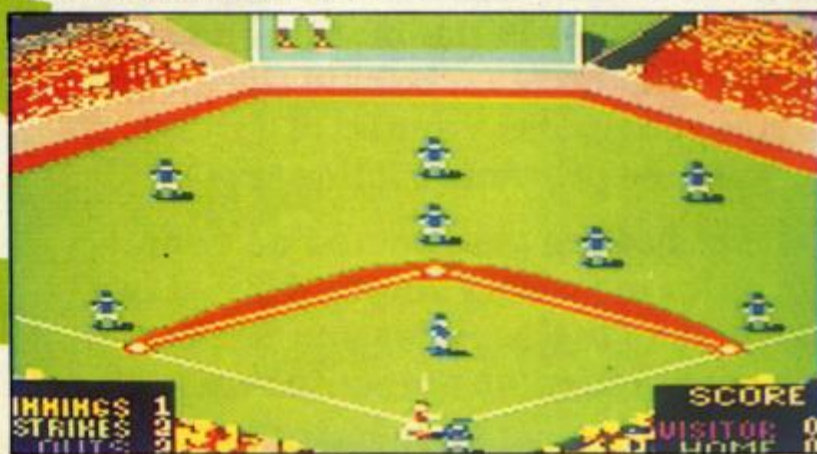

# PUTS THE GUESSWORK INTO ARTWORK...



**Y**ou've played Trivial Pursuit, and now here's your chance to show off a new set of skills. Pick up your joystick and play Pictionary®!

The boardgame that has become the NO.1 best seller in the USA has now hit Europe and the team behind the award winning computer version of Trivial Pursuit now presents Pictionary.

Hours of fun are guaranteed on your own or for the whole family. Played in a similar way to Charades you must draw your clues 'on screen' using a

specially designed, simple to use art package. With 2,500 challenging words to sketch, will you dumbfound your friends with your doodles?

*Available on:*

*IBM PC • Amiga • Atari ST •  
Commodore 64 cassette and disc •  
Amstrad cassette and disc •  
Spectrum +3 • Spectrum 48/128.*



DOMARK

Published by Domark Ltd, Ferry House,  
51-57 Lacy Road, Putney, London  
SW15 1PR. Tel: 01-780 2224

Programmed by Oxford Mobius

© Pictionary Inc., WA 98109 PICTONARY® is the registered trademark of Pictionary Inc. USA

# ZZAP!

64  
AMIGA

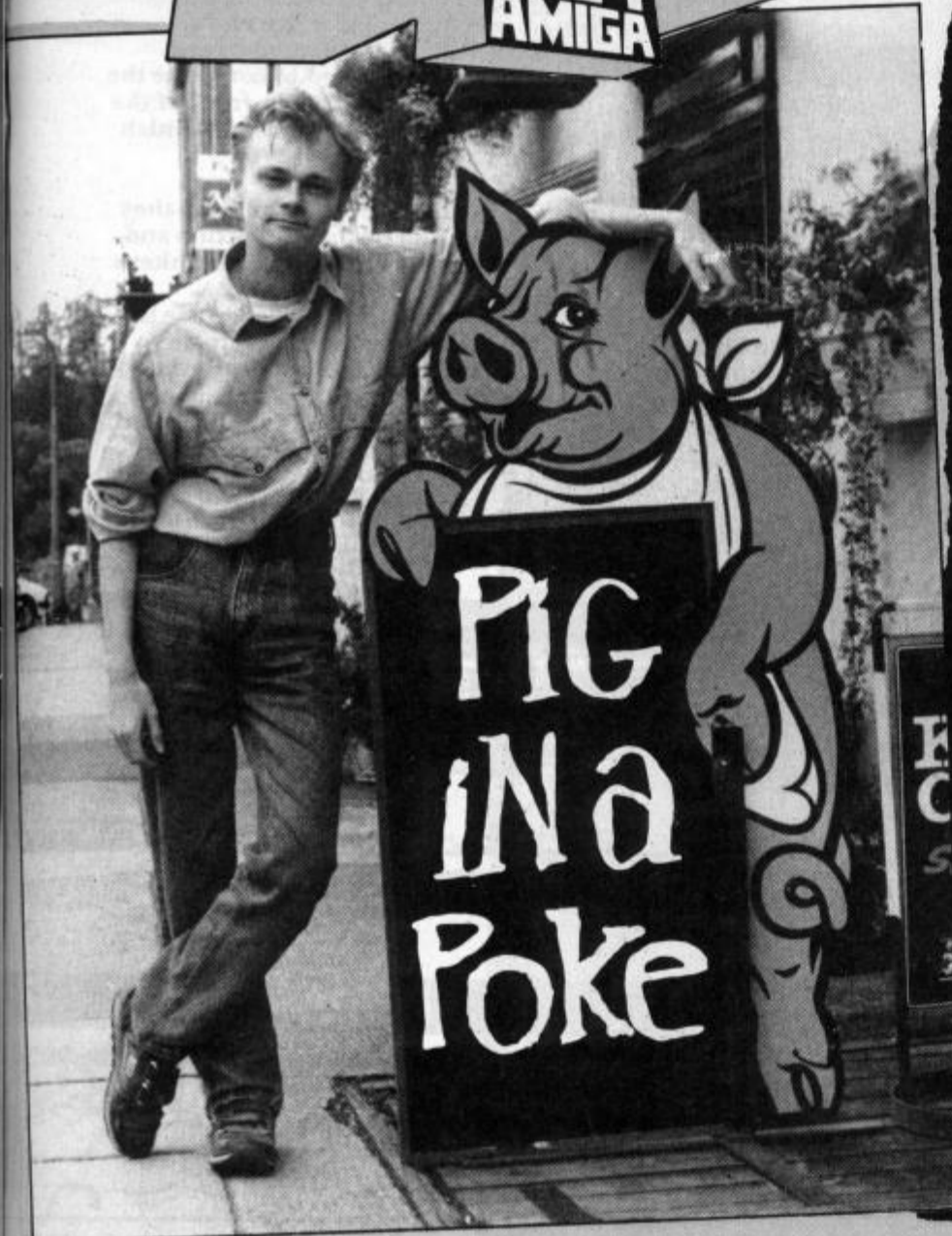

## HELLO MUM (AND EVERYONE ELSE IN SOUTH WALES!)

It's starting to become a regular thing, all this changing of the tippers, and here I am stepping into the firing line. This time around things are going to change and I'm hoping to have these pages absolutely CRAMMED full of tips. Just send in as many tips, POKEs, maps, solutions, etc, etc as you can. My desk is literally overflowing with many a piece of paper or rolled up map and I've got to sort through the lot and somehow put it all in. (Yes, Stu, I WILL have the tips finished by tomorrow, just let me have 'this one last game' of *New Zealand Story* and I'll get it done, OK!?). Ha! That fooled him!

Get those tips, old and new coming - I want anything and everything, and we can really make this a VFM tips section. Before we get down to the tips let me just say a quick hello to Kirsty B (How's Harold H?), Jackie S, Glenn H, (Mum - Hello Mum!), Melissa H, Vicki H, Harold H, Natasha M, Janice A, Anthony B, Mandy P, Gail M, Rachel G, Ian J, Kev R, D Dodgers, Yngwie JM, Gappa, Sara B, Ashley M, Jo R, Suzanne M, Mark S and anyone else who knows me. (Are you sure Suzanne Mizzi, Gail McKenna and Rachel Garley read ZZAP!? - Ed.)

Anyone with any moderately sized 'hellos' just send them in with your tips and I'll laugh at them, throw them in the bin, retrieve them and who knows, I may even print them.

Ok, enough of this drivel, ON WITH THE TIPS!!!!!!

## (ATTRACTIVE) AMIGA SECTION

### ARKANOID (Richard Milne)

Pause the game and type 'DSIMAGIC'. This restarts the game and promptly releases a mystery cylinder that activates the cheat mode when collected. Now press...

L for Lasers  
C for Catch  
F to confront Doh

### VIGILANTE (D. Price)

Get a high score and enter 'GREEN CRYSTAL' on the high score table. Start a new game and you can press F1 to add lives and F8 to skip levels.

### EXOLON (A Cool Froddy Dude (!?))

On the highscore table type in AD

ASTRA for unlimited lives.

### ARKANOID 2: REVENGE OF DOH (Seamus Slater)

Frustrated with having to start at Round 01 again?

Then type in 'ROBOCOPPER' on the title screen and you start from the screen where you left off. Easy.

### SILKWORM (Adam Watt)

When playing, if you press F1 to F10 you can slow the game down depending on which F key you press. Useful for dodging the fast moving missiles. Pressing the +/- key advances you to level 11.

### INTERNATIONAL KARATE (Seamus Slater)

Let somebody strike you down

then press the SPACE bar followed by the joystick button. You can now kick the stuffing out of the bad guys without them hurting you! Black belt easily now.

### POPULOUS

Maybe not a full cheat mode but at least it's not one of those soooo boring, space-wasting tables showing ALL the passwords for ALL the levels (Yawn!). Just do the following with Matthew and David Ember's worthy tips.

1. Load a CONQUEST game as normal.
2. Click on the GAME SETUP icon.
3. Change any game options you want then return to the GAME SETUP screen
4. Click on EVIL, then TWO PLAYERS, then CANCEL
5. You should have now returned to the main game screen. Now you'll be pleasantly surprised to find out that the enemy cannot build land but you can and that you

are back in the Conquest game! The game is now ridiculously easy to complete because the evil player has only a few huts where flat lands are naturally found, while you have fields full of castles in no time at all.

Incidentally the code for the last world (494) is WEAVUSPERT. Does anyone know the purpose of the unreachable worlds KILLHIPED (519), COROUTER (693) and QAZMELOW (601)? Alternatively why not try the VERY FINAL level 999 aptly named KILLUSPAL?

(Note: When using this cheat mode, icons may be lit at the wrong times. Ignore this, they still work as normal).

### ROBOCOP

During the all-out action put RoboCop's feet up and pause the game. Type in 'BEST KEPT SECRET' and Robo restarts with more energy than you could shake dollars at.



# TUSKER

Adrian Cale, full time brother to Mark and head of PR for System 3 came up at the eleventh hour with *Myth* and a convenient map and tips for *Tusker*. Load one this issue, load two next issue and load three the issue after that (by which time I expect everyone will have completed it ten times over). Show us how it's done Adrian.

First off, collect the necessary objects from the desert screens. The objects required are the GUN, AMMUNITION (FOUND IN LARGE BOX), ACID BOTTLE, KNIFE and a WATER BOTTLE for use later on.

On the desert screens if you're hit by whirlwinds then shake the joystick left and right to escape before your energy is sapped. To collect water first find the knife and water bottle and ensure that both are displayed as icons in the objects/weapons display. Now stand left or right of the base of a cactus and stab it to replenish your rapidly dwindling water supply.

Now enter the cave section through the cave entrance and enter the first lead-off cave. Inside is a chest which needs to be kicked or punched (keep trying both) within which is a book

revealing details of the quest ahead.

Enter the water section and use the knife to kill the alligator (an escapee from *Last Ninja 2* perhaps?). Enter the end cave beyond the water section and collect the gold nuggets and machete (the gold nuggets need to be collected to complete the game). If you are using the book, then standing in front of the wall will display all the screens which must be crossed to finish the load.

Exit the cave section and use the machete to remove bushes from in front of the jungle section. Enter the jungle section and move right while avoiding the wandering natives and monkeys up the trees.

You'll now come to the final screen where you need to use the acid bottle on or near the chains tethering the giant slug (No thanks! - Rob). The slug will be released and unsurprisingly will kill you if you stand in its way. Shooting the slug causes it to strobe between skeleton and normal but it cannot be killed.

Exit the load through the top right corner of the screen and Load 2 awaits.

The saga continues next month.

Gun and dagger are in any of these screens (random).

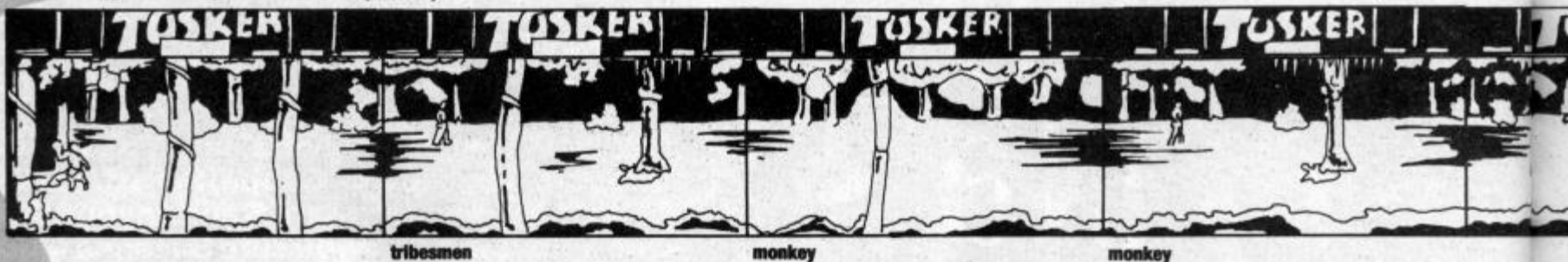

START HERE

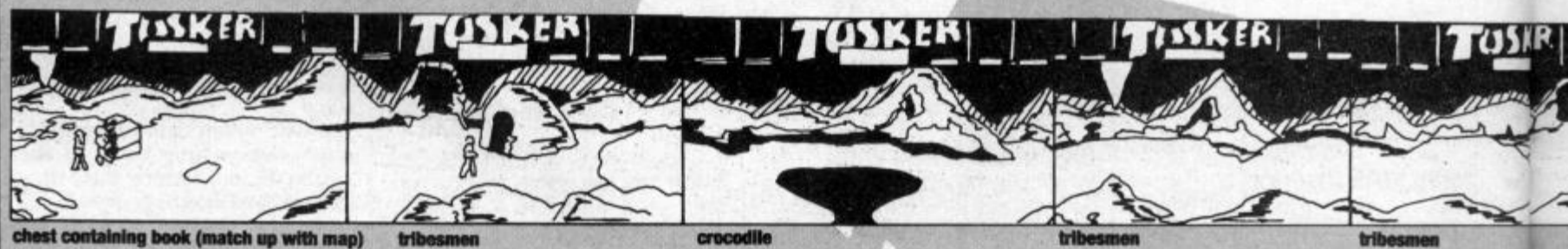
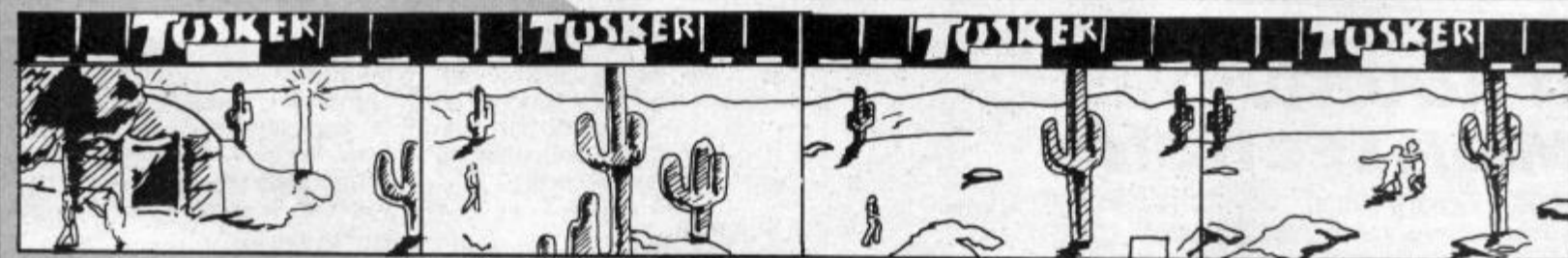

## (RAUNCHY) RESETS

Yes, for those of you with the old Reset button (or the dodgy paperclip) these Resets (plus SYS numbers) are yours. Load up, reset, type away and SYS that game!

**DIZZY (WAZ)**  
Poke 15942,173:SYS 8192

**FRUIT MACHINE SIMULATOR (A. Knight)**  
Poke 33615,173:SYS 32768

**GREAT GIANA SISTERS (Paul Marner)**

Poke 8257,4:SYS 2098  
(If you die on a level, you get jumped on to the relevant square root level further on - if there is one that is! Do not get killed on level 32 or the game will crash - Did that make any sense?)

**HAWKEYE (C. Corkin)**  
What a game! What a bunch of Pokes!  
Poke 7468,173  
Poke 6105,189  
SYS 23558 to get the SLF out there slaughtering life-forms.

**HELL FOR LEATHER (Hexy & Jack of the Cheaters)**  
Poke 9679,234 for endless lives  
SYS 4096 to get things going

**HERO OF THE GOLDEN TALISMAN (WAZ)**  
Poke 13458,173:Poke 13518,173:SYS 8192

**I BALL 2 (A. Knight)**  
Poke 38861,76:Poke 38862,210:Poke 38863,151:SYS 4050

**IMPULSE (Hexy and Jack of the Cheaters once more!)**  
Poke 49228,(0-4) - Change title music  
Poke 25170,(0-4) - Change game music  
Poke 28123,(0-4) - Change game-over sound  
Poke 24639,234:Poke 24640,234:Poke 24641,234 - No attack waves  
Poke 24708,234:Poke 24709,234:Poke 24710,234 - No sprite detection  
SYS 24576 to restart the game  
SYS 49152 to restart

**INDIANA JONES AND THE LAST CRUSADE (Raistlin)**  
Nice to see tips coming in for

this one - but with the cheat later on you're spoilt for choice).

Poke 32552,173 - Unlimited Lives  
Poke 37255,173 - Unlimited Whips  
Poke 35756,123 - Unlimited Light/Torches  
SYS 32092 to send Indy off crusading

**INTO THE EAGLE'S NEST**  
Poke 24651,234:Poke 24652,234:Poke 24653,234:SYS 32784

**JACKLE & WIDE (WAZ)**  
Poke 26442,189:SYS 16384

**LEONARDO (Raistlin)**  
The codes are elsewhere in the tips section but here we go with some short but sweet Pokes (pity the same can't be said about the game itself).

Poke 20238, X (X = Start Level 1-52)  
Poke 34117,0 - Unlimited lives  
Poke 34350,169 - Invulnerability  
Poke 34352,234  
Poke 34391,252 - Unlimited Time  
Poke 38162,252 - Unlimited Time in the bonus sections  
Poke 31304,128 - Jump straight to the end screen  
SYS 19456

**LICENCE TO KILL (Raistlin)**  
Poke 8448,173:Poke 11565,173 - Unlimited Lives  
Poke 14730,173:Poke 15185,173  
Poke 36581,189 - Unlimited Time  
Poke 11559,173:Poke 11544,0 - Unlimited Energy  
Poke 12494,173  
Poke 13591,173 - Unlimited Bullets  
SYS 2056 to kick things off

**KENDO WARRIOR (Raistlin)**  
Well, this is novel, we only had the game itself a couple of days ago. Talk about quick - yeah, this is what we want! As usual reset the game and type away

Poke 15115,36 - Unlimited Lives  
Poke 15483,36 - Unlimited Energy  
Poke 15502,169  
Poke 15503,0 - One hit to kill all enemies  
SYS 2176

**MONKEY MAGIC (An extremely old one from WAZ)**  
Poke 8488,173:Poke 9266,173:Poke 9491,173:Poke 32627,173:SYS 2077.

**MUNCH MANIA (WAZ)**  
Poke 20572,173:SYS 19271

**NAVY MOVES Part 1 (WAZ)**  
Poke 5851,173:SYS 3584  
(The code for the second part is 2277)

**PHOBIA (A. Knight)**  
Poke 5390,189:SYS 2172

**RALLY CROSS SIMULATOR (Another newbie again from Raistlin)**  
Poke 3822,96 - Unlimited Time  
Poke 4376,44 - Unlimited Fuel  
Poke 4302,44 - Immune to damage  
SYS 2071

**RED MAX (A. Knight)**  
Poke 5224,255:SYS 2064

**RICK DANGEROUS (Raistlin)**  
Poke 27931,173 - Unlimited Lives  
Poke 11193,173 - Unlimited Bombs  
Poke 10886,173 - Unlimited Shots  
SYS 2057 to get a near invulnerable Rick into the thick of the action - watch out Goolus!

**ROBOCOP** - Poke 44416,0: SYS 32768

**ROLLERBOARD** - Poke 51038,165 with an SYS 32777 to follow

**(THE) SENTINEL** - Poke 6679,173:Poke 8512,10:SYS 16128

**SCARY MONSTERS** - Poke 45719,165:Poke 45860,165 for Infinite lives  
Poke 43765,165 for infinite wavy hands (?)  
Once input type SYS 4096 to start.

**SKYJET (Grant Robson)**  
After resetting set variables  
A = 53271  
B = 53277  
then Poke A,1  
Poke B,0  
or Poke A,1  
Poke B,1  
for different size helicopters. Follow this up with an SYS 29350 to start.

**SLUG (Hexy and Jack of the Cheaters again!)**  
Poke 9420,44:Poke 6658,44:Poke 4620,(0-7 - see for yourself)  
Type SYS 11619

EXIT TO NEXT LEVEL



map on the wall



PIG IN a Poke

# PROJECT

# FIRESTART

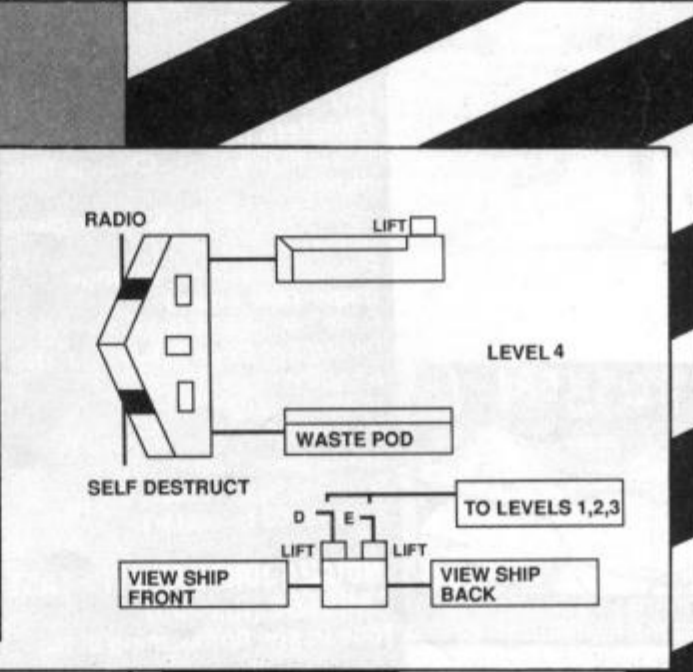
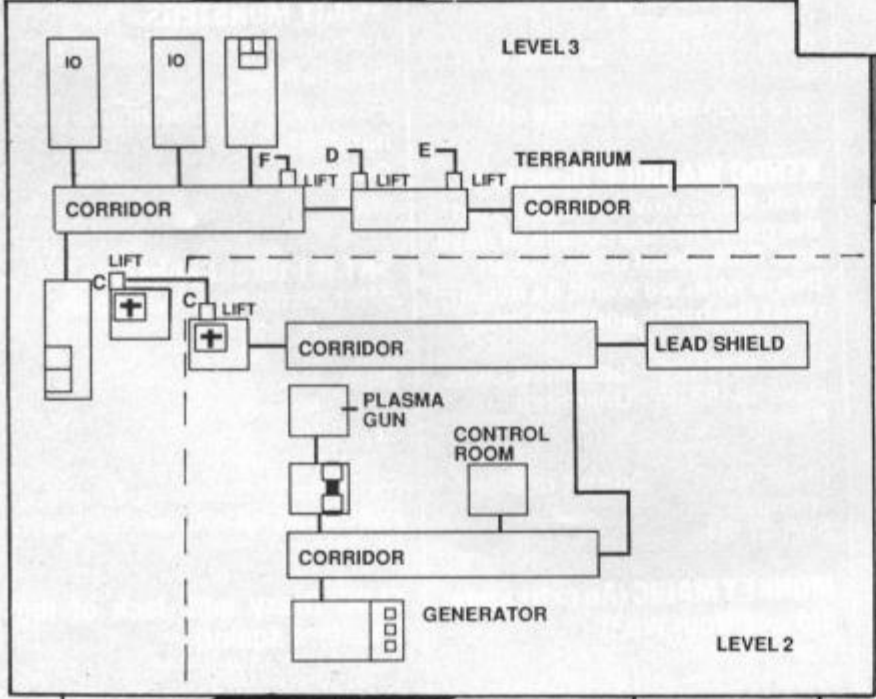
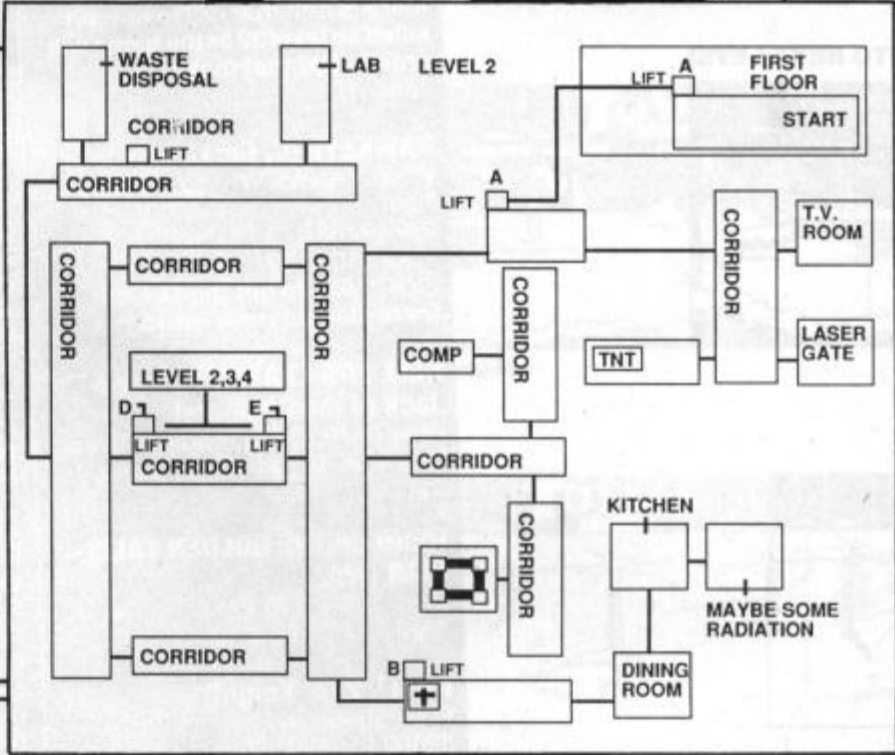
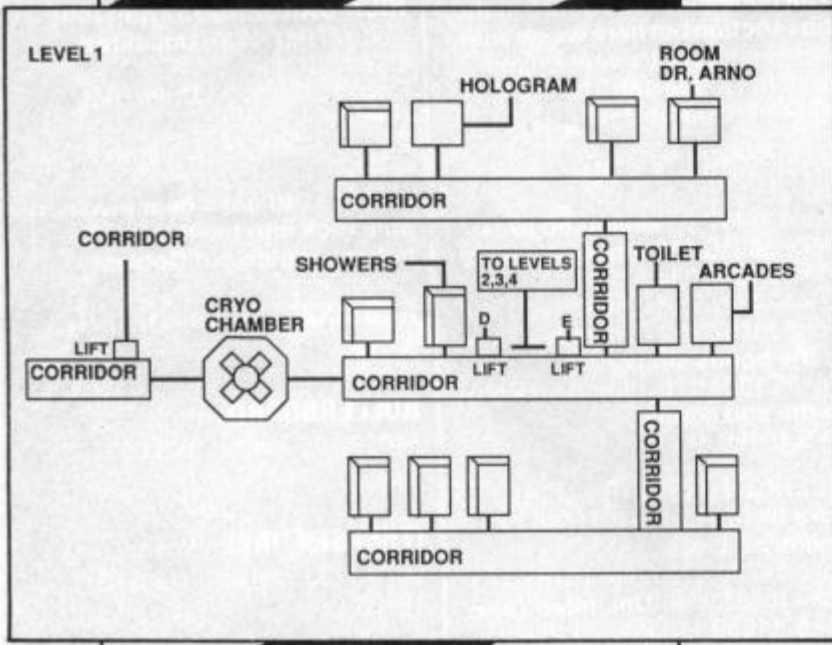



# FREE! TENSTAR PACK WORTH OVER £229!

# Commodore AMIGA



FREE! - AMEGAS - by Players



FREE! - INSANITY FIGHT - by Microdeal



FREE! - ART OF CHESS - by SPA

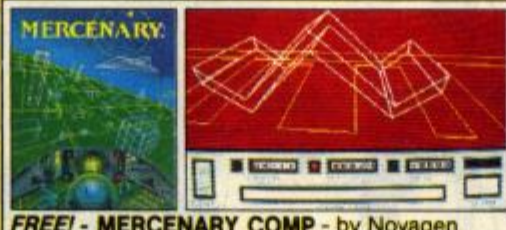

FREE! - MERCENARY COMP - by Novagen



FREE! - BARBARIAN, ULT WARRIOR - by Palace



FREE! - TERRORPODS - by Psygnosis

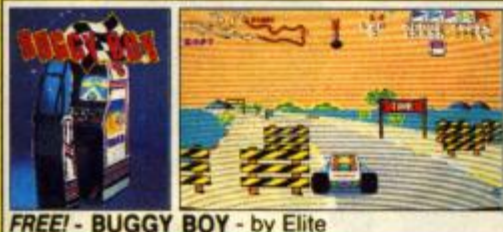

FREE! - BUGGY BOY - by Elite



FREE! - THUNDERCATS - by Elite



FREE! - IKARI WARRIORS - by Elite



FREE! - WIZBALL - by Ocean



ONLY £3.34 PER WEEK  
RETURN COUPON FOR DETAILS

# £346.95

+VAT = £399

INCLUDES FREE UK DELIVERY

The Amiga 500 is one of a new breed of technologically advanced computers, which are now emerging as the new standard for home computing, based around the new Motorola 68000 chip. The A500 has 512K RAM and a 1Mbyte double sided disk drive built-in. It can be connected directly to a wide range of monitors, or to a domestic TV set through a TV modulator. Designed with the user in mind, the A500 features a user friendly WIMP environment and comes supplied with a free mouse. And, when you buy your Amiga from Silica Shop, the UK's No1 Amiga specialists, you will experience an after sales service that is second to none, including a technical support helpline and free newsletters and price lists. Return the coupon below for our current information pack, which will give details of the Silica service and the very latest Silica Amiga offers. E&OE.

## WHY SILICA SHOP?

Before you decide when to buy your new Commodore Amiga computer, we suggest you consider very carefully WHERE you buy it. There are MANY companies who can offer you a computer, a few peripherals and the top ten selling titles. There are FEWER companies who can offer a wide range of products for your computer as well as expert advice and help when you need it. There is ONLY ONE company who can provide the largest range of Amiga related products in the UK, a full time Amiga specialist technical helpline and in-depth after sales support, including free newsletters and brochures delivered to your door for as long as you require after you purchase your computer. That one company is Silica Shop. We have been established in the home computer field for ten years and can now claim to meet our customers requirements with an accuracy and understanding which is second to none. Here are just some of the things we can offer you:

**THE FULL STOCK RANGE:** The largest range of Amiga related peripherals, accessories, books and software in the UK.

**AFTER SALES SUPPORT:** The staff at Silica Shop are dedicated to help you to get the best from your Amiga.

**FREE NEWSLETTERS:** Mailed direct to your home as soon as we print them, featuring offers and latest releases.

**FREE OVERNIGHT DELIVERY:** On all hardware orders shipped to Silica Shop customers within the UK mainland.

**PRICE MATCH PROMISE:** We will normally match our competitors offers on a 'same product same price' basis.

**FREE TECHNICAL HELPLINE:** Full time team of Amiga technical experts to help you with your technical queries.

But don't just take our word for it. Complete and return the coupon below for our latest Amiga literature and begin to experience the Silica Shop specialist Amiga service.

## PHOTON PAINT PACK

A500 Computer	£399.99
TV Modulator	£24.99
Photon Paint	£69.95
TenStar Pack	£229.50
<b>TOTAL RRP:</b>	<b>£724.43</b>
<b>LESS DISCOUNT:</b>	<b>£325.43</b>
<b>PACK PRICE INC VAT:</b>	<b>£399</b>

## 1084S MONITOR PACK

A500 Computer	£399.99
1084S Colour Monitor	£299.99
Photon Paint	£69.95
TenStar Pack	£229.50
<b>TOTAL RRP:</b>	<b>£999.43</b>
<b>LESS DISCOUNT:</b>	<b>£350.43</b>
<b>PACK PRICE INC VAT:</b>	<b>£649</b>

## FREE FROM SILICA

When you buy the Amiga 500 from Silica Shop, you will not only get a high power, value for money computer, we will also give you some spectacular free gifts. First of all, we are now including a TV modulator with every A500 stand alone keyboard, so you can plug your Amiga straight into your TV at home (the modulator is not included with the A500+A1084S pack as it is not required for use with monitors). Secondly, we have added a free copy of Photon Paint, an advanced graphics package with an RRP of £69.95. Last (and by no means least!), so that you can be up and running straight away, we are giving away the sensational TENSTAR GAMES PACK with every A500 purchased at Silica Shop. This pack features ten top Amiga titles which have a combined RRP of nearly £230! Return the coupon for details.

## FREE TENSTAR PACK

Amegas	£14.95
Art Of Chess	£24.95
Barbarian, Ult Warrior	£19.95
Buggy Boy	£24.95
Ikari Warriors	£24.95
Insanity Fight	£24.95
Mercenary, Comp	£19.95
Terrorpods	£24.95
Thundercats	£24.95
Wizball	£24.95
<b>TOTAL RRP:</b>	<b>£229.50</b>

INC VAT

## DO YOU OWN AN AMIGA?

If you already own an Amiga computer and would like to be registered on our mailing list as an Amiga user, let us know. We will be pleased to send you copies of our price lists and newsletters FREE OF CHARGE as they become available. Complete the coupon and return it to our Sidcup branch and begin experiencing a specialist Amiga service that is second to none.

## SILICA SHOP:

<b>SIDCUP (&amp; Mail Order)</b>	<b>01-309 1111</b>
1-4 The Mews, Hatherley Road, Sidcup, Kent, DA14 4DX	
OPEN: MON-SAT 9am - 5.30pm LATE NIGHT: FRIDAY 9am - 7pm	
<b>LONDON</b>	<b>01-580 4000</b>
52 Tottenham Court Road, London, W1P 0BA	
OPEN: MON-SAT 9.30am - 6.00pm LATE NIGHT: NONE	
<b>LONDON</b>	<b>01-629 1234 ext 3914</b>
Selfridges (1st floor), Oxford Street, London, W1A 1AB	
OPEN: MON-SAT 9am - 6.00pm LATE NIGHT: THURSDAY 9am - 8pm	

To: Silica Shop Ltd, ZZAP1189, 1-4 The Mews, Hatherley Road, Sidcup, Kent DA14 4DX  
**PLEASE SEND ME FREE LITERATURE ON THE AMIGA**

Mr/Mrs/Ms: ..... Initials: ..... Surname: .....

Address: .....

Postcode: .....

Do you already own a computer  
If so, which one do you own? .....

# THALAMUS

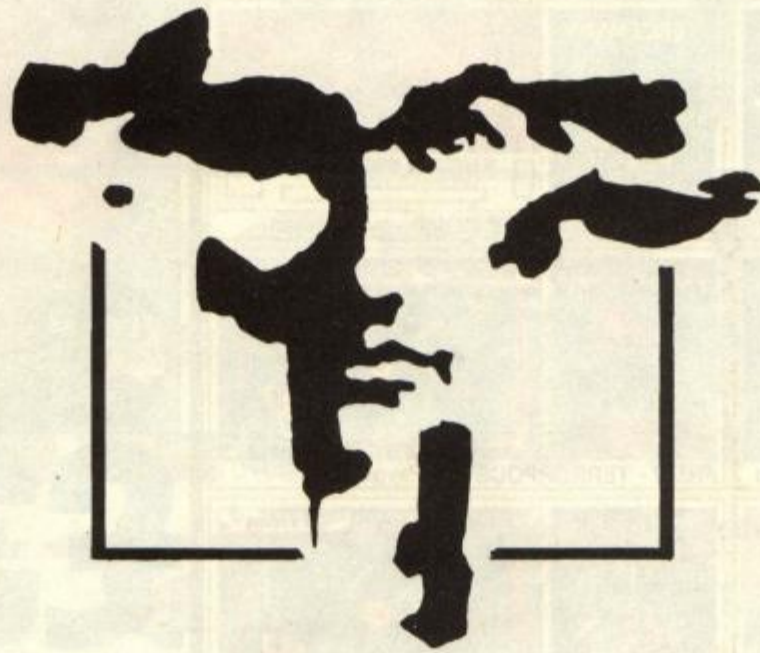

## THE HITS

1986 - 1988



SANXION



DELTA



QUE-DEX



HUNTER'S MOON



HAWKEYE

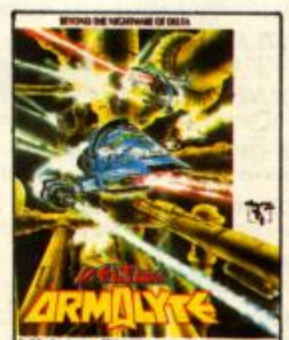

ARMALYTE

Six smash hits bringing you the very best from Thalamus' first two years. These games are so hot they've received more awards than we can mention here: Sizzlers, Gold Medals, Screen Stars, Super Stars, Hits, ACE Rated . . . It's the ultimate collection this year!

CBM 64/128 CASSETTE £12.99 DISKETTE £17.99

# ROBOTS



Now don't start blaming me, it was Maff's fault. I don't know, printing the Spectrum map without first checking that the two games were the same layout. Which it wasn't. After much consideration (as well as numerous telephone calls telling ME that I'VE got it wrong! Sheesh!) I've decided to succumb to reader pressure (for a change) and print a revision to the 'iffy' level - no. 5, to be precise. Oh look, here it is now.

Compiled by Andrew Roberts

## LEVEL 5

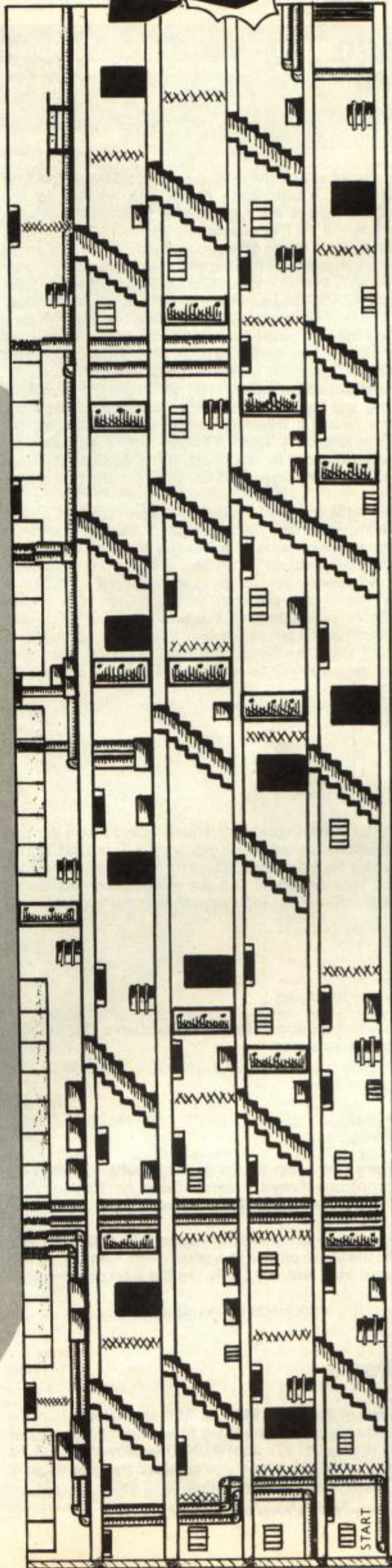

-  **KEY**
-  **IMPASSABLE BARRIER**
-  **LIGHT**
-  **VENT**
-  **BOX**
-  **DOOR**
-  **BARREL**
-  **PIPE**
-  **COLUMN**

**ZAP** (PIG IN a Poke)



# PIG IN a Poke

## WASTELAND (Electronic Arts)

### Quartz

This is a fairly large town with three main points of interest. The first is the Courthouse, which has three floors and an exit to the Stagecoach Inn. Both places are easier with an SMG or Assault Rifle. Always carry some TNT or plastic explosive. The first level hasn't got much apart from some gunmen and a stairway. Go up on to the second level, kill some men, then go down and along a corridor. A sprite of a man is in your way, but just walk past him. Go past a guard (you automatically put him out) and go into the North-east room. There you will find Ugly's toughs and a man being tortured. Blow the triplets to kingdom come and rescue the prisoner (known as Don Citrine) by giving him a canteen. Also, give him a pistol. You must also 'hire' him on the attack menu to make him a follower.

Next, get into the room below (using TNT) and show the gamblers some hot lead. They will leave a substantial amount of money. Go onto the third floor which is the 'Quartz City Jail'. Go along the corridor - you will see four cells. Use TNT on the room with the bed. A man will give you \$1000 cash for rescuing him. Break into the next cell above that and rescuer Mayor Pedros, then get the hell out of there!

Enter the green-house thing on the Ground Floor and go to the bottom. Keep pressing down and you'll go into a tunnel. At this stage you must have some 'snake squeezing' to get past the bum. Use Padlock skill on the first cabinet to receive a servo motor. Some housekeepers don't like what you're doing and put up a fight. Show them the smokin' barrel of your gun and continue. Go to the Stagecoach Inn. There are 20 rooms, but find out what each one contains yourself (hint; don't shoot the Laurie in room 18, hire her instead). There is nothing in the Swimming Pool. Go to the lobby and ask for a room; that way, you will be given a pass key. Use strength to get into the Reception Area.

The last area of interest is the Quartz Emporium where you can buy some firearms.

### Savage Village

This is a place of little importance. Entrance is gained with the use of Plastic Explosive on the gates. A few guys come down but, hopefully, your gun is faster than theirs. Don't go through the secret door as it only leads you outside. Check out the village Weapons Room though, as well as the Ammo Dump beneath it in the top-left hand corner.

### Las Vegas

This is the next hardest location after the Guardian's Citadel. DO NOT ENTER unless you possess:

- An Assault Rifle
- An SMG
- Grenades
- A Chainsaw
- And Plenty Of Clips

In Vegas, there are two main things to look out for - Warriod Mk.3's and the Scorpotron - if any are encountered, run for your life!

There are some RPG-T's on the Golf Course - sell at the Black Market.

In Spade's Casino, there are plenty of humans to obliterate and rob. Keep held onto the laser-pistols like grim death. Climb onto the Bar by using Acrobat skill and say 'hello' to the barkeeper with a 9mm clip.

The little square at the back leads to the mine cellar.

### Darwin Village

This is the home town of the Black Market. At first you have to run a kamikaze mission to enter the damn thing (there are two guards at the entrance, each with a Uzi 27). Just RUN, then buy a Uzi. Come out, and let the full clip BURN!. Once you've killed the guards pick up their Uzis and clips. Now you have three.

## THE SOUND OF MUSIC

It's all well and good having infinite lives, energy, trident missiles and the like. But what about those of us who just want to listen to some (mostly) pleasant music flooding forth from our battered C64s? Here then is the place just for you.

### COMBAT SCHOOL (Dan Morey and Stu Hedges)

You want odd music? You want space invader music pouring forth from your *Combat School*? Well press RUN-STOP and RESTORE when you start the assault course. Now do 500

push-ups for saying yes too many times. 'Ten Hut!

### HERO OF THE GOLDEN TALISMAN

A music hack from WAZ who normally hacks into the games for lives and other such things. Poke 252, 0:Poke 54296,15:SYS 8335

(Try replacing the 0 in the first POKE with a 1)

### JUMP JET

The oldie Anirog game gets the WAZ treatment with this program which allows you to play all the speech from the game at any pitch! Load the game up and give it a reset. Then type in the following program. Try it, it's good for a laugh!

10 S=0:P=100:PS=STRS(P):P  
OKE 650,128

### Highpool

I tend to like this place (being a sadistic pig and all!) because there a lot of folks to pump lead into. Go into the building next to the infirmary and look under the bed.

Next, go out and slip in the stream to reveal a nice, plump kiddy. Let fly with a chainsaw or (if preferred) a flamethrower. Keep on doing this until the famous Red Ryder pops up. Make sure he pops right on down again - BANG!

### Needles

There is an Ammo Dump next to the police station where you'll find some power packs (the clips for the laser pistols - 40 shots per clip) and other useful items.

DON'T GO INTO THE SECOND CUBICLE FROM THE RIGHT - it's a bit explosive!

When travelling downtown, don't fire the Howitzer - it blows up. Also, don't pay the three legged 'woman of ill repute' \$50 either - there ain't no clinics round here!

There are two Bloodstuffs in Needles - one is behind an alley of rubble (along with a few guys) while the second is in the possession of two guards. Don't put either in the Bloodstuff table.

Do try the Fast Food Stall, though; the Hobodogs are yummy! In the Boutique, there is a small stall entitled 'Leroy's Arms Counter', as with the Quartz Emporium, he doesn't sell a particularly wide range of goods, but it's an ideal chance to make money if your own inventory is full.

### Rail Nomads

The first thing that springs to mind is 'How the HELL do you get into the tents?'. Well, on the middle tent, use the word 'Caterpillar' to gain access. Kill the sly dudes who rush you with full autos on every available gun (take out the baby first as he has a weapon) then collect the loot and go to the left hand tent. Say 'Caterpillar' and you'll be given a shovel and directions to some local treasure.

At the end of the train, the brakeman gives you a Visa card to hand to Head Crusher. Keep giving the Hobo more 'snake squeezing' to get information. There is also a trading car and a casino car.

### Mine Shaft

Nothing of real interest is to be found in this underground world, apart from the odd band of 'Little People' (they make great target practice!)

```

20 POKE 53280,0:POKE
53281,0:PRINT CHR$(147)
30 PRINT
CHR$(19);CHR$(30);"CUR-
RENT SPEECH = ";S;TAB
(20); "PITCH = ";P$
40 GET AS:IF AS="+" THEN
P=P+1:IF P>200 THEN
P=200
50 IF AS="-" THEN P=P-1:IF
P<20 THEN P=20
60 IF P<100 THEN
P$=""+STR$(P):GOTO 80
70 P$=STR$(P)
80 IF AS<"1" OR AS>"9"
THEN GOTO 30
90 S=VAL(AS):POKE
1042,48+S:POKE 151,S-
1:POKE 57610,P:SYS
18176:GOTO 30

```

### THE LAST NINJA

An oldie game but as Benno Goede of the Netherlands points out, it's not been done before (as

far as he and us know).

Load up the game, reset the machine and type this program in (or load it in as sensible types do). Run it and type SYS 49152 and POKE 54296,15 and (to quote Benno) 'wola, you can hear the great music play'. Thanx Benno.

```

10 10 FOR I=0 TO 50
20 READ A:POKE
49152+I,A:NEXT
30 PRINT "START THE
SOUND WITH: SYS 49152"
40 PRINT "AFTER THAT TYPE
POKE 54296,15"
50 END
60 DATA 120,169,22,141,20
70 DATA 3,169,192,141,21
80 DATA 3,162,0,142,14
90 DATA 220,232,142,26,208
100 DATA 88,96,169,1,141
110 DATA 25,208,169,131,141
120 DATA 18,208,169,27,141
130 DATA 17,208,169,1,141

```

```

140 DATA 32,208,32,2,64
150 DATA 206,32,208,76,49
160 DATA 234,96

```

### MUNCH MANIA

Load and reset and type this in. Poke 54296,15:SYS 17348. Et voilà, music galore to munch to.

### PLATOON (Sadist Software from Finland - Er, yeah)

Not a POKE in sight or any sign of a reset switch for this one. Instead load up the game and wait for the title tune to play. Now press 'O' to switch off the music and begin the game. When the message 'Entering Combat Zone' appears press 'M' to switch the music back on. The computer gets confused and plays the brilliant title track music instead of that accompanying the level 1 action. This only works on level 1 though.

### RED HEAT (Stuart Bolton)

Load the game, reset it, enter SYS 6464 and press RUN/STOP to listen to the music.

### SHAOLIN'S ROAD (Grant Robson)

Do the usual load/reset business and type this in to replay the music at the desired speed (0 is the fastest).

```

10 INPUT "SPEED (0 TO 255)
";A
20 SYS 35800
30 FOR L=0 TO A: NEXT L
40 GOTO 20

```

### THUNDERBIRDS (The old one from Firebird, not the new one sadly)

Load up, reset and Poke 18633,96 with an SYS 18479 to get Thunderbirds are Go!

## WOT, NO COLLISIONS?

A great hack here from Thrasher which disables sprite collision from most of the older games around. The newer games aren't catered for as the programmers don't tend to use the built-in hardware SS/SD collision detection registers. Experiment to find out what games do work with it, there's still a hell of a lot of games out there.

In fact, Thrasher suggests that you take a look through some of the older ZZAP!s for the relevant SYS calls for games which employ sprites. To get you going, here are some SYS calls.

Delta SYS 6000  
Monty On The Run SYS 2064  
Raid Over Moscow SYS 2178  
Thrust SYS 2304  
Warhawk SYS 24604

Thrasher would like to say thank you to Adam Fellows for letting him borrow his 64. Thanks too from ZZAP! otherwise we wouldn't have got the listing!

```

1 REM SS/SD COLLISION
DISABLE
2 REM BY THRASHER! (c)
1989
3 REM SYS 820 - DISABLE
SPRITE/SPRITE
4 REM SYS 830 - DISABLE
SPRITE/DATA
5 REM SYS 840 - DISABLE
SS & SD
6 REM
10 L=100:SA=820:FOR A=0
TO 24:FOR B=0 TO 7
20 READ C:D=D+C:POKE
SA+B,C:NEXT B:READ CK

```

```

30 IF CK=D THEN D=0:SA=±
SA+8:NEXT A:GOTO 50
40 PRINT "ERROR IN LINE ";I-
a*10:END
50 NS="SS/SD COLLI-
SION":INPUT "INPUT
TAPE OR DISK (T/D)";DS
60 D=8:IF DS="T" THEN D=1
70 SYS 57812NS,D
80 POKE 193,52:POKE
194,3:POKE 174,250:POKE
175,3
90 SYS 62957:END
100 DATA
32,199,3,32,193,3,32,79,57
3
110 DATA
3,96,32,199,3,32,187,3,555
120 DATA
32,79,3,96,32,52,3,32,329
130 DATA
65,3,96,120,173,32,208,72,
769
140 DATA
169,127,141,13,220,169,52,
133,1024
150 DATA
1,169,0,170,168,133,251,16
9,1061
160 DATA
8,133,252,169,248,133,253,
230,1426
170 DATA
1,238,32,208,198,1,177,251
,1106
180 DATA
221,181,3,240,26,162,0,200
,1033
190 DATA
108,237,230,252,198,253,2
08,231,1817
200 DATA
169,55,133,1,169,129,141,1
3,810
210 DATA
220,104,141,32,208,88,96,2
32,1121
220 DATA
224,3,208,227,152,56,233,2
,1105
230 DATA
176,2,198,252,168,162,0,18
9,1147

```

```

240 DATA
184,3,145,251,200,208,2,23
0,1223
250 DATA
252,232,224,3,208,241,76,1
21,1357
260 DATA
3,173,30,208,169,0,234,169
,986
270 DATA
30,141,182,3,96,169,31,141
,793
280 DATA
182,3,96,173,134,2,72,162,
824
290 DATA
0,189,221,3,32,210,255,232
,142
300 DATA
224,30,208,245,104,141,13
4,2,1088
310 DATA
96,147,5,83,83,47,83,68,61
2
320 DATA
32,68,73,83,65,66,76,69,53
2
330 DATA
32,66,89,32,84,72,82,65,52
2
340 DATA
83,72,69,82,33,13,0,0,352

```

(i) Type in and RUN the listing, making sure there are no errors.  
(ii) Insert a tape or disk ready to save the master.  
(iii) When you want to reload the program, just reload the saved master under the name 'SS/SD COLLISION'.  
NB: When reloading, you MUST either put  
LOAD 'SS/SD COLLISION',1,1 for tape  
LOAD 'SS/SD COLLISION',8,1 for disk

### TECHNICAL NOTES

The code is positioned in mem-

ory from \$0334 to \$03FA. It works by hunting for a specific 3 bytes and, once found, are replaced with something less harmful.

The 3 places in which the code can be executed are: \$0334 - SYS 820 disables all sprite/sprite collision  
\$033E - SYS 830 disables all sprite/data collision  
\$0348 - SYS 840 disables sprite AND data collision

The code is stored in the cassette buffer so that it won't mess up any program resident in memory.

### INSTRUCTIONS

This routine isn't guaranteed to work on every program available, but it will still work on a vast majority of commercially written titles.

To use it, load up the required game (THRUST, for example).

Reset the computer once loading is complete, then load the already saved master routine (NOT the one which you typed in, but what you saved after RUNNING it!)

Choose what you want to disable:

ie Sprite/Sprite  
Sprite/Data  
Both

Once the changes are made, restart the program with the required SYS call (if you don't know the SYS, check your back issues, where a SYS call was probably printed (espeh ish 31)) If you still can't find the call, you can always look through the program code and find it for yourself, which isn't too difficult as long as you know what you're looking for!

## (BUSTY) BITS AND BOBS

### LEONARDO (Raistlin - He gets about a bit I must say)

Codes for levels 10,20 and 30

Level 10 - MOONWALKER

Level 20 - FOOTBALL

Level 30 - BLITTER

Try some other codes for different results - CHEAT, ALPHORN, EMMENTALE, MATTERHORN, FREIBER, HELP, ELITE, MOVERS, THRUST, STARVBYTE, RAGMAN, CONAN, JOKER and some swear words.

### BASIL - THE GREAT MOUSE DETECTIVE (KAZMELAD)

For the first level you will need PAW PRINT, KNIFE, SMOKING CIGARETTE, GUN, KEY

For the second level you need BOWLER HAT, ACE OF DIAMONDS, SHOE, SCROLL, SPANNER

To enter the third level - find the first port hole, go right and through the next port hole, go left, up and right 4 screens. When you have all the objects, a step ladder will appear leading to the third and final level.

### BEAT-IT (WAZ)

Load up the game, Press 'S' on the title screen and lo and behold you have a screen editor - use the joystick to design the screens and the following keys to do other miscellaneous things to your hearts content.

L - Loads screen in from memory (any of 60)

S - Saves screen in memory

(Move the joystick left or right to choose the relevant screen)

F3, F5, F7 - change screen colours

C - Saves/Loads all 60 screens to/from tape

D - Does the same but for disk

F1 or RUN/STOP - Quits the editor to let you play with your screens

CLR/HOME - clears the screen

### DANGER FREAK (Russel Gowrie)

When it asks for the Date, type 170470 to activate the cheat mode.

### DOMINATOR (Jason Nightall)

On level 1, destroy yourself when you start and press SPACE as you explode. Now the level keeps going without your ship on screen. To start again anywhere on the level just release SPACE, press SHIFT and SPACE again. This works on levels 2,3 and 4 as well.

### FORGOTTEN WORLDS (Bobby Shah)

Select the 2 player option. Play the SECOND (BROWN) player and when the first player cops it all the bullets and enemies aim at the dead player as if he were still there. You subsequently sail through the whole game without taking damage!

### INDIANA JONES AND THE LAST CRUSADE

A bit of an odd one this game, on the Amiga it was downright awful but on the 64 it turned out remarkably better. Here we go though with the cheat mode.

Hold down F,I,S,H (the second name of the programmer Alex Fish). Now you can press keys 1-5 to play the relevant zones of each level with 6 to advance to the next.

Not a bad little cheat at all.

### MACH

Type in 'STARVISIONIC' on the high score table to give yourself invincibility

**NAVY MOVES (PART 1) (Felix Black)** Load side 2 of the tape and press CTRL when the 'Enter Access Code' screen comes up and you get to try a new Operation altogether - Operation Octopus no less.

## RENEGADE 3 - THE SURVIVOR'S GUIDE

(Imagine)

Andrew Roberts of St. Helens in finest Merseyside is an industrious fellow, sending in maps (such as *Citadel*) tips, pokes and the like all the time. Now he turns his hand to *Renegade 3* to give us renegades a helping hand.

### Level One - The Stoneage

Captain Caaaavemaaaaan! Being the most difficult level, most people will have torn out loads of hair. Never fret, help is at hand. The safest way to dispose of the dragons is to low-punch them (they can't bite your head then, see). This is the best tactic for the cave-men as well, as kicking them usually results in a club bashing to the head. Incidentally, the club which can be picked up has no real use until Level Two. Pity. Use the map to anticipate when you should climb up or down ladders - you'll waste valuable time, otherwise. Twelve enemies must be killed at both the end and the half-way point.

### Level Two - Ancient Egypt

Using the club from Level One will help you to kill those 'dogs' a touch more easily. If you lost a life and therefore have no club, either high-punch

### NAVY MOVES (PART 2) SOLUTION

Courtesy of the industrious WAZ comes the easy way through Dinamic's otherwise tough aquatic arcade adventure. Go to it WAZ!

Go right and down the lift. Keep running right till you see a officer in a brown uniform. Blow him away and examine the corpse. take the code number from him and write it down. Go left, back up the lift and in the door. Go right, shoot the blue officer and take his number as before. Go back, left and in the door. Now go up the lift, keep running right, down two lifts, go right, up the lift. Enter the door on this screen. Go down the lift, then lift, up the lift and left. Go in this door. Go left. Ignore the two doors and go up the lift. Done that? Now go left and in the door. Go up the lift and go right. Go down the lift and in the door. Ignore the brown officer - you've got his code number. Go right and in the door. Do that again. Go left and down the lift. Go in the door you see. Now go to the door on the left. Go right, down the lift. Do that again. Now keep going left for ages! Shoot the brown officer. Examine him and take his code number.

You should now have 3 different code numbers. Keep moving left until you can't go left anymore. Push up at the green screen and you log onto the computer. Type OPEN DOOR (Return). Then enter the FIRST code you found. The door should open. Type END (Return) to leave the computer. Go left and keep going left until you are informed that the bomb is set. Log on to the computer you just logged on and type STOP MOTORS (Return). Enter the SECOND code you found and type EMERGE (Return). Now type TRANSMIT (Return) and type in the THIRD and last code. The computer prompt will now request you to ENTER MESSAGE. Enter OABERBYAMD (Return). Now leave the computer by typing END (Return). Go right, up the lift, up another lift. Go left, go up a lift and another one, and yet another one. You should be on top of the sub. Go left until your mate picks you up and sit back and watch the end sequence and not a bad one it is either.

### OPERATION WOLF (Sadist Software from Finland - Dodgy!)

Just a small tip and straightforward enough but let's this be the last as *Op Wolf* has been tipped to death already.

Anyway, just plug a second joystick into Port 1 and you have a rocket firing joystick to hand. Better than the old one-hand-on-the-space-bar routine I guess.

### OSMIUM

Nice speech - shame about the game!

Anyway, typing '←OSMIUM' on the title screen brings forth infinite lives in abundance (infinite abundance no less).

### PETER PACKRAT

Not really a cheat for this budget coin-op conversion but pressing F1 and F3 changes the colours on the top half of the screen, likewise F5 and F7 changes the colours on the bottom half - useless really but at least it looks nice.

### PHOBIA

When you die and it says Rewind Tape, DON'T! Leave it running and the next level loads in. Simple.

### RAMBO 3 (Christopher Torres)

When the game loads press all the keys and the star on the Ocean logo will stop flashing. Press them again the star will flash again giving INFINITE LIVES. Pressing any of the CRSR keys will move you around each screen of the current level.

or flying-kick them. The large mummies are easily disposed of, but their smaller counterparts are not! It's possible to punch them when they jump up. Also beware of dripping water (acid?)

### Level Three – The Castle

Most of the enemies here take 3 or 4 punches or hits to kill. It is better to flying kick the knights, and low-punch the jesters. The dragons (Flying pigs? Police in helicopters?) can be killed by three high punches. Oh yes, if you come across a seemingly impassable wall, kill about 14 enemies to lower it - it's a drawbridge! By the way, the knights on hobby horses cannot be killed. You have been warned.

### Level Four – The Spaceship

A nice soundtrack on this level - a sort of title tune remix (Shuttup! – Rob H). Right. Remember to avoid the electricity cables, and jump the smaller ones. Use the teleporters (no ladders here, mateys) to your advantage (if you're getting beaten up). The hardest enemy here is the large droid - flying kick it. The mutant may also cause a few problems - high punch it. At the end of the level, everything will stop. No, it hasn't crashed. Look! Your girlfriend has come to rescue YOU in a time machine! Bah, humbug!

Well, that's a twist on the tale if ever I heard one. What a wimp that Renegade is though, losing his girlfriend in the first place.

### THE REAL GHOSTBUSTERS (Kester Johnson)

Yet another simple cheat based around the familiar multi-load concept.

When you die at the end of the game instead of rewinding the tape, just let it carry on to arrive at the next level with full laser power and a full set of lives.

### SALAMANDER (Neil Hunt)

When your last life goes up in smoke simply put on auto fire and you will keep playing. Isn't that good?

### SHANGHAI WARRIORS (Lord of Tips - Well let's see some more then!)

If one of the real 'ard men comes on and you haven't got a weapon to your name, don't whimper and run for the hills. Get as near to the left hand side of the screen as possible and turn to face him. Let him beat you off the screen and when you're out of sight push left on the joystick, and thinking you're dead the hard nut bad guy walks off. To come back on push right but don't come back too soon or they'll be back).

### SILKWORM (Zahid & Muzayed of Small Heath)

Start as the helicopter and, when your last life is gone, quickly press fire and up and keep it there. The level scrolls on to the end. Now put another joystick in the other Port and press SPACE. The jeep pops up and you can carry on with the mission.

### SPEEDBALL

Well done James and Richard Wilson of Hull who've finally cracked one of the most addictive future sports games yet - why it's none other than *Speedball* so get cracking (or should that be hacking?).

```
1 X=528
2 READ Y:IF Y=-1 THEN 4
3 POKE X,6:X=X+1:GOTO 2
4 POKE 157,128:SYS 528
5 DATA 32,44,247,32,108,245,169,76,14,1
6 DATA 43,141,57,3,169,2,141,58,3,76,168,2
7 DATA 72,77,80,72,169,58,14,1,178,3,169,2,141
8 DATA 179,3,104,,76,81,3,72,169,74,141,214,152
9 DATA 169,2,141,215,152,104,32,191,3,96,76,2
10 DATA 169,89,141,73,138,169,2,141,74,138,108,22,0
11 DATA 169,173,141,122,52
12 DATA 169,173,141,68,52
13 DATA 162,0,169,0,157,209,39,232,138,201,10,208,245
14 DATA 76,1,8,-1
```

(Line 12 is unnecessary unless you want to cheat Player 1 if you are Player 2)

### THUNDERBIRDS (Adrian Bostock)

This one has been around long enough in the shops (well over 2 months) and is just ripe for the slaughter! Here are the code words which also work on the Amiga version as well.

m  
LEVEL 1 (Mine Menace) ..... (No Password needed)  
LEVEL 2 (Sub Crash) ..... RECOVERY  
LEVEL 3 (The Bank Job) ..... ALOYSIUS  
LEVEL 4 (Countdown to Terror) ..... ANDERSON

And that's it for this jam-packed month. Give me your thoughts on the new tips section, what should remain, what should get booted out (preferably not me!) but more importantly send me those tips. Old, new, borrowed (but not from other mags) or blue (do *Strip Poker* cheats fall into this category?) – just SEND THEM IN!!! All will be eternally grateful and a crisp £30 software voucher could wing YOUR way for the best map, solution, pokes, music hack, compliments, fan mail, pin-up photo of yourself (if you're female of course!) or whatever, just get them sent! This month's £30 goes to Thrasher for that ever so clever hack to disable collision detection, now what about a more up-to-date version?

The address? Why obviously enough *Pig in a Poke, ZZAP! Towers, PO BOX 10, Ludlow, Shropshire, SY8 1DB.*

To quote the great Sledge Hammer himself – 'Trust me, I know what I'm doing'. So, till next month – keep rocking!

## !!!!!! TIPS INDEX WINNER !!!!!!

The judges rise from their seats, the tension is electric as the winner of the ZZAP! TIPS INDEX is announced. The entries were many and varied and Robin Hogg's desk was cluttered up with them all. Now the time came to make that final decision! The oldest judge speaks ...

'Ladies and Gentlemen... ' (GET ON WITH IT YOU OLD BUF-FOON! - The Crowd)

'Er yes, the Winner is... [cue drum roll] .....  
**DAVID WHITEHOUSE** of Kettering, Northants with a very neatly laid-out index proving clear to read, concise and a boon for my tips section to come). Well done David! A hot £60 software voucher should be in the post to you very soon which you may well receive before Xmas 1992 if our post is anything to go by! CONGRATULATIONS!!!!!!

[Commiserations of course to the losers who also put a hell of a lot of work into their indices (see, I know the proper plural!). The vast majority were very professionally done and came in *extremely* handy for my first tips section, I can tell you].

## TIPS LINE

For the best in aural entertainment with red hot action just a phone call away why not try out the ZZAP! Tips Line – not read by us idiots here at ZZAP! but some idiot from the recording company – ah well, you can't win 'em all. Phone this number ...

# 0898 555086

... for some up-to-the-minute stuff on the up-to-the-minute stuff!

# zuperstore

## SOFTWARE HITS



BATTLETECH	Infocom	£15.99
CONTINENTAL CIRCUS	Virgin	£11.99
CURSE O.T.AZURE BONDS	SSI	£19.99
DEMON'S WINTER	SSI	£15.99
DOMINATOR	System 3	£11.99
HALLS OF MONTEZUMA	SSG	£15.45
HOSTAGES	Infogrames	£11.99
INDY:THE ACTION GAME	US Gold	£11.99
INT. TEAM SPORTS	Mindscape	£11.99
JACK NIKLAUS GOLF	Accolade	£13.45
OVERRUN!	SSI	£19.99
POWER DRIFT	Activision	£11.99
PROJECT FIRESTART	Electronic Arts	£11.99
REAL GHOSTBUSTERS	Activision	£11.99
TESTDRIVE II THE DUEL	Accolade	£13.45
THE UNTOUCHABLES	Ocean	£11.99
TUSKER	System 3	£11.99
VIGILANTE	US Gold	£11.99
XENON 2	Melbourne	£11.99
ZZAPI SIZZLER COLL 1	US Gold	£11.99

### C64 cassette

AAARGHI	Melbourne Hse	£ 7.99
AMERICAN CLUB SPORTS	Mindscape	£ 7.99
APB	Domark	£ 7.99
BATMAN:THE MOVIE	Ocean	£ 7.99
CONTINENTAL CIRCUS	Virgin	£ 7.99
COSMIC PIRATE	Byteback	£ 2.99
CRYSTAL CASTLES	Kix	£ 2.99
DOMINATOR	System 3	£ 7.99
INDIANA JONES	US Gold	£ 7.99
INDY:THE ACTION GAME	US Gold	£ 7.99
KENDO WARRIOR	Byteback	£ 2.99
MR. HELI	Firebird	£ 7.99
PITSTOP II	Kix	£ 2.99
POWER DRIFT	Activision	£ 7.99
REAL GHOSTBUSTERS	Activision	£ 7.99
SPEED BALL	Imageworks	£ 7.99
STORMLORD	Hewson	£ 7.99
TESTDRIVE II THE DUEL	Accolade	£ 7.95
THE UNTOUCHABLES	Ocean	£ 7.99
THUNDERBIRDS	Grandslam	£10.40
TUSKER	System 3	£ 7.99
VIGILANTE	US Gold	£ 7.99
WORLD SERIES BASEBALL	Hitsquad	£ 2.99
XENON 2	Melbourne	£ 7.99
ZZAPI SIZZLER COLL 1	US Gold	£10.44

### C64 disk

AMERICAN CLUB SPORTS	Mindscape	£11.99
APB	Domark	£10.44
BATMAN:THE MOVIE	Ocean	£11.99

### AMIGA

3D POOL	Firebird	£15.99
AMERICAN ICE HOCKEY	Mindscape	£19.99
APB	Domark	£15.99
ARCHIPELAGOS	Logotron	£19.99
BALANCE OF POWER	Mindscape	£19.99
BATTLEHAWKS	Lucasfilm	£19.99
BATTLETECH	Infocom	£19.99
BEACH VOLLEY	Ocean	£19.95
BLOOD MONEY	Psygnosis	£19.95
COLOSSUS CHESS X	CDS	£19.99
CONTINENTAL CIRCUS	Virgin	£15.99
DEMON'S WINTER	SSI	£19.99
DOMINATOR	System 3	£15.99
F-16	Dig. Integr.	£19.95
FIRE BRIGADE	Mindscape	£23.99
GOLD RUSH	Sierra	£19.99
GRAND PRIX CIRCUIT	Accolade	£19.95
GUNSHIP	Microprose	£19.95
HAWKEYE	Thalamus	£15.99
INDIANA JONES	US Gold	£15.99
KULT	Exos	£19.95
LORDS O.T.RISING SUN	Cinemaware	£19.99
MICROPROSE SOCCER	Microprose	£19.95
MILLENNIUM 2.2	Electric Dreams	£19.99
PRO TENNIS TOUR	Ubi Soft	£19.99
RVF HONDA	Microstyle	£19.99
SHOGUN	Infocom	£23.99
SLEEPING GODS LIE	Empire	£19.95
STRIDER	Capcom	£15.99
TESTDRIVE II THE DUEL	Accolade	£19.95
W. GRETSKY HOCKEY	Mindscape	£19.99
WINTER'S TALE	The Edge	£19.99
XENON 2	Imageworks	£19.99

## BACK ISSUES

No 49 May 1989  
Are You Console Crazy? Renegade III, Cybernoid 2, Voyager Silkworm, Robocop, War In Middle Earth! Batman map!

No 50 Jun 1989  
PHOBIA DEMO & ZIG ZAG - THE REMIX CASSETTE! Tips Special! Xenon, Speedball, Battlehawks 1942, The Muncher, Powerdrome, The Kristal, Forgotten Worlds, Kick Off, Hillstar! Forgotten Worlds Poster!

No 51 Jul 1989  
Massive 5-page Strategy Special! Phobia, Project Firestart, Test Drive II, Archipelagos, Blood Money, Millennium 2.2, Wicked, FOFTI Powerdrome poster!

No 52 Aug 1989

Batman! Free Bat poster! Psygnosis Special! Reviewed: Citadel, Rick Dangerous, 3D Pool, American Club Sports, Navy Moves, Baal, Deja Vu II, Journey, Zork Zero, Waterloo, Tank Attack, Astaroth, Vindicators, Time Scanner, The Newzealand Story, Wayne Gretzky's Hockey, Microprose Soccer, Gunship, Hawkeye, Xybots

No 53 Sep 1989  
Fresh from the Ocean - Ocean in high gear for Xmas release period! Reviewed: The New Zealand Story, Rainbow Islands, Gemini Wings, Inner Space, Hostages, Grand Prix Circuit, The Champ, Personal Nightmare, Demon's Winter, Curse of the Azure Bonds, Breach, Fire Brigade, Laser

Squad, Indiana Jones, Licence to Kill, The Running Man, Red Heat, Kuit, Tom & Jerry, A Garfield Winter's Tail, Fiendish Freddy's Big Top of Fun, Savage, Phobia, Dominator

No 54 Oct 1989  
Interview with Power Drift programmer Chris Butler! Randy's Tips Extravaganza! Test Flight - Falcon vs F-16 Combat Pilot! Reviewed: First Strike, Thunderbirds, Tusker, Skate Ball, Team Sports, Shinobi, APB, Xybots, Aaargh!, Paperboy, Jack The Nipper, Ghosts 'n' Goblins, Masters of the Universe, Rescue on Fractalus, Mr. Hell, Xenon 2, Buffalo Bill's Wild West Rodeo Show, Omni-Play Basketball, Strider, Sleeping Gods Lie





'CHA KIDS!  
BUY LOADS A STUFF  
AND KEEP ME IN  
SUPPLY OF LOTS  
OF SWEETIES!



© KEN IS A LAD PRODUCTION.

# HARDWARE



#### KONIX MEGABLASTER

Precision moulded control knob with steel shaft for complete reliability. Dual fire buttons for left and right hand use. Heavy duty leaf switches and rubber suction cups.  
**OFFER \$6.99**

#### EUROMAX COBRA

Brand new design with 8 microswitches, 3 Autofire buttons and single normal fire button provide trigger readiness.  
**OFFER \$11.95**

#### EUROMAX ELITE STANDARD

Short travel microswitch action in ergonomic and highly durable design.  
**OFFER \$9.95**

#### EUROMAX ELITE GRIP

Same as Elite Standard, but with new ergonomic grip.  
**OFFER \$10.95**

#### EUROMAX PROFESSIONAL STANDARD

High durability, rapid response and ultra sensitive movement.  
**OFFER \$15.95**



#### ZZAPI T-SHIRT

The favourite T-Shirt in Medium and XX Large sizes. 50% cotton and 50% polyester.

XX LARGE AND MEDIUM OFFER \$4.95

#### ZZAPI BINDER

Have a binding relationship with your favourite computing mag! Maroon with Gold logos.  
**OFFER \$4.50**

#### ZZAPI KEYBOARD COVER

Protect your old faithful from dust, coffee and the universe with these super quality grey covers complete with ZZAPI logo made to suit your keyboard

#### CBM64 FIT OFFER \$5.00

CBM64C FIT OFFER \$5.50

CBM128 FIT OFFER \$5.50

#### KONIX NAVIGATOR

Brand new ergonomically designed handheld joystick with Fire Button positioned directly beneath the trigger finger.  
**OFFER \$14.99**

#### EUROMAX PROFESSIONAL GRIP

Same as Professional Standard, but with ergonomic grip.  
**OFFER \$13.95**

#### EUROMAX PROFESSIONAL AUTOFIRE

Same as Professional Standard, but with Autofire.  
**OFFER \$18.95**

#### EUROMAX MICROHANDLER

An array of features: extra-sensitive microswitch action, two integrated paddles, variable Autofire, extra large fire buttons and solid metal casing with rubber suction cups.  
**OFFER \$19.95**

#### DYNAMICS COMPETITION PRO 5000 (NORMAL)

Features arcade quality microswitches, dual fire buttons, robust steel shaft and rubber return for smooth control.  
**OFFER \$13.50**



#### DYNAMICS COMPETITION PRO 5000 (CLEAR)

Same as PRO 5000 NORMAL, but with see-thru body.  
**OFFER \$14.00**

#### DYNAMICS COMPETITION PRO EXTRA

Features Rapid Fire, unique slow motion and see-thru body.  
**OFFER \$15.00**

#### POWERPLAY CRUISER STREAMLINE ALL BLACK

With dual lead for Spectrum 48K/128K/Plus/Plus2/Plus3.  
**OFFER 12.99**

#### POWERPLAY CRUISER CLEAR AUTOFIRE

Simply by holding down either of the fire buttons engages Autofire.  
**OFFER \$12.99**

## How to order

Apart from our highly recommended games list, you can order any game released by the major software houses to date on cassette, disk or cartridge.

The offer prices on our games list include a generous discount and are inclusive of First Class postage.

If you wish to order a game not included in the list, please use the following Special Offer discount table to calculate your Offer price from the recommended retail price quoted on the software houses adverts.

#### SPECIAL OFFER DISCOUNT TABLE

RRP	OFFER	SAVE
4.99	3.99	1.00
5.95	4.74	1.20
7.95	6.40	1.55
7.99	6.44	1.55
8.95	7.20	1.75
8.99	7.24	1.75
9.95	7.95	2.00
9.99	7.99	2.00
11.99	9.99	2.00
12.95	10.40	2.55
12.99	10.44	2.55
14.95	11.95	3.00
14.99	11.99	3.00
19.95	15.95	4.00
19.99	15.99	4.00
23.00	18.40	4.60
24.95	19.95	5.00
28.95	23.15	5.80
29.95	23.95	6.00
34.95	27.95	7.00

Remember, apply the discounts to RRP prices only, not to our discounted Offer prices quoted on this page! Don't forget to indicate which computer you own and whether you require the software in cassette, disk or cartridge form. Similarly, don't forget to indicate garment size for T-shirts.

Prices valid for UK/Eire/Europe only. For Overseas orders please add \$2.00 per item for Air Mail delivery.

Not all listed or advertised products will have been released at press time. Goods will be despatched as soon as possible. Customers will be informed of any long delays.

Please ring (0584) 5620 for release dates!

## BUDGET SPECIAL OFFER!

Order four games in the \$1.99 range and pay for three (\$5.97 payment total) - a saving of \$1.99!

Order four games in the \$2.99 range and pay for three (\$8.97 payment total) - a saving of \$2.99!

**POWERPLAY CRYSTAL STANDARD**  
Clear joystick with red fire buttons and pistol grip handle.  
**OFFER \$14.99**



**POWERPLAY CRYSTAL TURBO**  
Same as CRYSTAL STANDARD, but includes fast Autofire action.  
**OFFER \$16.99**

**AMIGA A501 512K RAM EXPANSION UPGRADE + CLOCK CARD**  
Internal Ram upgrade to 1024K RAM.  
**OFFER \$129.99**

**AMIGA A520 MODULATOR**  
Use your Amiga with a domestic TV set or composite video monitor.  
**OFFER \$24.99**

# A MOVIE subs deal!

Subscribe to ZZAP! and you get a **FREE FULL-PRICE MOVIE TIE-IN** as a subscription gift!

**BATMAN:THE MOVIE** cass  
**THE UNTOUCHABLES** cass  
**INDY:THE ACTION GAME** cass

Take your pick from any of these fab games - it's yours free when you subscribe to ZZAP! And remember: You'll get

- 12 brilliant issues of ZZAP! delivered straight to your door!!!
- **FREE one of three** games cassettes offered!!!
- the chance to participate in future special subscription offers!!!

**Send in your coupon today!!!**

If you're already a subscriber and don't want to resubscribe yet, you can participate in this amazing offer by sending in a paltry £6.95 for either one of the three games!

I want to subscribe to 12 issues of ZZAP! and receive my subscription gift.  
If I've already got a ZZAP! subscription, and it is running out soon, I extend it for a further twelve issues - and still get my subscription gift.  
If I am a current subscriber, but do not wish to extend my subscription, I can still get one of the three subscription offers at a ridiculous £6.95!

Please tick the appropriate box:

- I enclose £18.00 for a new ZZAP! subscription mainland UK
- I enclose £25.00 for a new ZZAP! subscription out side mainland UK - surface mail
- I enclose £38.00 for a new ZZAP! subscription out side Europe - Air mail
- I enclose £6.95 for the special subscription offer of my choice

- I am a new subscriber
- I am an existing subscriber. My subscription number is

Please extend my subscription starting with issue No:

Please send me the following subscriber discount offer:

- BATMAN:THE MOVIE** cass
- THE UNTOUCHABLES** cass
- INDY:THE ACTION GAME** cass

(Please tick required item)

### EARLY WARNING:

If you wish your sub to commence with issue 56, we must receive your coupon no later than 18th October 1989.

Please allow 28 days for your free gift.

# ORDER FORM

MY COMPUTER IS:

CODE	ITEM	PRICE

The software discount table may only be applied to recommended retail prices as seen in the ads of this magazine, not on OFFER prices shown within the ZZUPERSTORE pages. No other discounts may be applied.

SUBTOTAL

### ZZAPI BACK NUMBERS

Normal back issues £1.45 (inclusive P&P)

Xmas issues £2.15 (inclusive P&P)

**OVERSEAS** please add £0.80 to above prices.

### SPECIAL QUANTITY DISCOUNT:

Order 4 issues and pay for 3

please supply the following **BACK NUMBERS** (Circle required items)

05 08 12 13 14 15 16 17 18 19 20 21  
22 23 24 25 26 27 28 30 31 32 33 34  
36 37 38 39 40 41 43 44 45 46 47 48

BACK NUMBER ORDER TOTAL

ORDER TOTAL

Name

Address

Postcode

Please make cheques/postal orders payable to **ZZAPI** It is best to avoid sending cash payments. Please **DO NOT** enclose ANY order with mail to the EDITORIAL side of the magazine as this will result in DELAYS! Send your orders to the address below.

I enclose a cheque/p.o. for:

I wish to pay by **VISA/ACCESS**  
(Delete as appropriate)

Please debit my **VISA/ACCESS ACCOUNT** by:

My account No. is:

Expiry Date  Signature

SEND THIS FORM TO:

**ZZAPI ZZUPERSTORE, PO BOX 20  
LUDLOW, SHROPSHIRE SY8 1DB**

520ST<sup>FM</sup>

ANOTHER ELECTRIFYING DEAL...

ATARI

# Evesham Micros

PRESENTS THE

# POWER PACK



**£349.00**  
inc. VAT/delivery

- R-Type
- Pacmania
- Out Run
- Nebulus
- Black Lamp
- Afterburner
- Starglider
- Bombuzal
- Star Goose
- Overlander
- Double Dragon
- Super Huey
- Xenon
- Super Hang-On
- Bomb Jack
- Eliminator
- Gauntlet II
- Space Harrier
- Predator
- Star Ray



INCLUDES  
**23**  
SOFTWARE TITLES  
WORTH OVER  
**£500**



**ORGANISER** also included; Helps manage business and personal information. Features Wordprocessor, spreadsheet, address book and diary. Powerful, yet easy to use.



**FIRST BASIC** a full featured and complete version of this ideal programming language.



**MUSIC MAKER** features MIDI compatible composer, drum editor and voice editor.

# Evesham Micros

How to order from  
**Evesham Micros**

Phone us with your  
**ACCESS** or **VISA**  
card details on :  
**0386-765500**

All prices include VAT and delivery. Express Courier delivery £5.00 extra.

Send cheque, Postal Order or ACCESS/VISA card details

Govt., educ. & PLC orders welcome  
Same day despatch whenever possible  
All goods subject to availability, E.&O.E.  
Open to callers 6 days, 9.30-5.30

Also at: 1762 Pershore Rd., Cotteridge, Birmingham B30 3BH Tel: 021 458 4564

**Evesham Micros Ltd**  
63 BRIDGE STREET  
EVESHAM  
WORCS WR11 4SF  
**0386-765500**  
fax 0386-765354  
telex 333294

# powerdrift

Test  
64



Activision, C64 £9.99 cassette, £14.99 disk

● Power up for the best 64 race game yet.

**W**ell you must be feeling on top of the world right about now. You've driven your Ferrari across California in record time, ridden rough shod over some of the gnarliest Moto Cycle Cross courses in the world, hell you've even decimated an entire air force at the request of the US Navy. But now let's see the TRUE stuff that you're made of. Yep, this time Sega have cooked up a real tough one for you - we've put you in for the Power Drift league.

We've heard a lot of good reports about your driving skills but can you handle a hot rod with a souped-up engine and the heart of a 4x4? Sure you can, but

be warned, you're not the only out there with the need for speed.

Power Drift is played over five different courses with five different circuits to be found in each course. At the start of the game any course can be chosen and any one of 12 drivers can be chosen from to take to the hot seat. Revving up at the start with the other 11 all around you it's now or never. Putting the pedal to the metal, 224 km/h worth of engine roars up and the opponents eat your dust.

Round the first bend, you deftly slam the car into high gear and the others are far behind. Taking the second bend doesn't leave much paint left on your

▲ You're in fifth position and supposedly look like the fifth guy from the left!



Well it's a toss up between this and Chase HQ for Xmas, but Ocean's coin-op conversion will have to be pretty spectacular to beat this immensely fast conversion. It's great to see that most of the coin-op's features are in there: the ramp, spinning off the road, falling off edges, and even the driver selection option complete with individual gestures! On the negative side I'm not too sure about the depth of play and long term variety of the gameplay but the coin-op was to fault in this respect also. Considering what Chris Butler has done in one load you can't fail to be overwhelmed by it all. So what if the graphics don't move past with 100% precision? Considering the C64's graphical limitations, Chris has attempted the impossible and succeeded in very fine style. The speed and fun of the coin-op is all there and that's what counts in this true roller coaster of a ride.

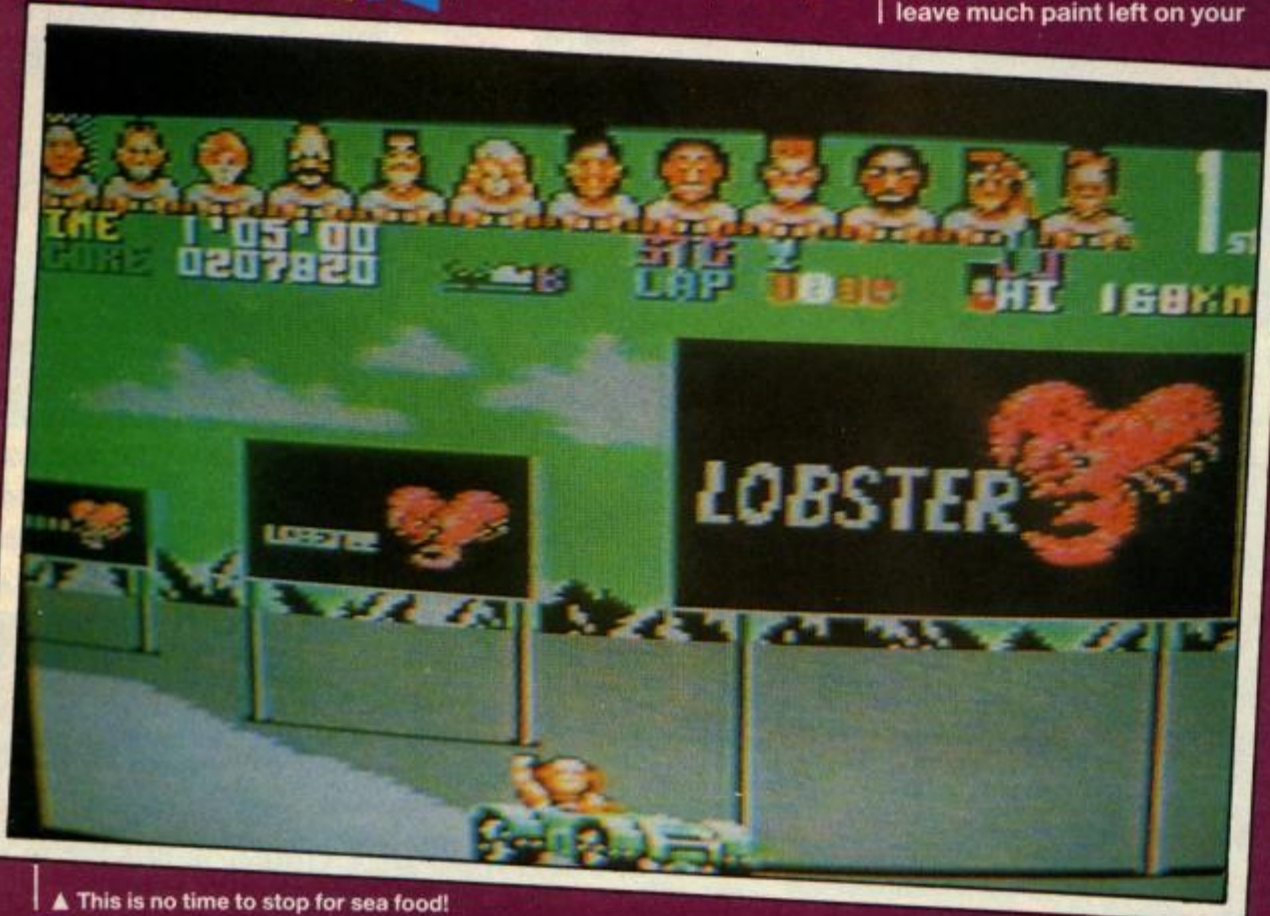

▲ This is no time to stop for sea food!

**Afterburner** is my personal favourite in the arcades but that was a disaster in the process of conversion to the C64. Now we come to **Power Drift**, and having played the arcade machine to death I was highly sceptical that it could be done at all.

Once again I am proved wrong and deservedly so with what must be the best 3-D racer yet to grace the Commodore. Sure, it hasn't got all the extensive arcade graphics, but programmer Chris Butler has gone all out to retain the high-speed action, and as such, the pace and spirit of the coin-op have been kept perfectly intact. The superb sprite of your car and driver is well animated with other cars rushing past at speeds *beating* the coin-op (I'm not kidding!). The side graphics have considerable detail, although you have to stop to really appreciate their quality, much like the coin-op really!

Wonderful stuff that does Activision and the C64 proud.



bone-shaking roller coaster ride.

Complete all five circuits and the next course beckons. Fancy turbo-ing around the bridge course or rocketing through the palm beach circuits, or how about a desert burn up with your hair blown back (who needs hair dryers?!). Take your pick of the next course and change the driver if you want, but go all out to win that trophy. GO FOR IT!

Once again Activision have entered the Xmas fray with a lot of credibility resting on a 'impossible' Sega arcade conversion.

I found the C64 version quite a bit easier to get into than the coin-op with very few prangs or sharp corners to cost you the race. However, on later circuits the gravity effect of bends makes its presence felt and at 224 km/h it's no picnic, I can tell you.

It's a great shame that the effect of climbing hills is spoiled somewhat by the lack of side graphics. However this doesn't stop the enjoyment as you ride to the top and, in true roller coaster fashion, subsequently plunge over the other side. The speed of the game and rush of oncoming cars and hills is enough to keep your stomach hanging in mid-air for most of the race!

The limited sound effects are disappointing although the ongoing music is well above average. And in unfair comparison with the coin-op, any loss of variety in the graphics is hard to notice as each course is markedly different in style with bridges, rock faces, palm and pineapple trees, and road signs all mixed up to ensure variety throughout all 25 circuits. And all this in one load! Truly amazing!

car, but what the hell? – this buggy can put with a lot of damage. Only a head-on collision with a sign, tree, post, or another car can spin this baby off the road. Woah! Over a ramp you go and the car is flying! Back down to the earth and the buggy is really roaring along now with the tyres smoking round the corners. Past the start line again and it's the second of four laps underway. Uh oh, here comes a dawdling car but he's moving so slow he looks like he's going backward and **YOU'RE GONNA HIT HIM!!!!**

Spinning off the road is a new experience which you can do without and now you're down to fourth place – if you don't end up in the top three then you're out of the race and can find your own way home mate! Those rival cars sure are fast and like you they take those bends with no thought for safety; theirs or others! When you burn past that third-placed driver, show him what you think of his driving with a 'suitable gesture'. (Wadd'ya

mean it ain't suitable for a family mag like this, just do it!).

Those high rides sure are fun but don't forget that you're talking stratosphere in height so don't wander too near the edge of the road unless you want to fly. It's not an F-14 this time boy!

Lap three follows and lap four begins – you're in second place and the leader is burning around the course, over hills, round twisting bends, and under bridges. No time to admire the scenery, even if does remind you of relaxing palm beaches. Just go flat out!

The computer controlled leader crosses the line and is displayed in all his glory as 1st just to rub it in. Never mind second is respectable but no time for a breather – it's off to the second course and after that another three more. This time watch out for the slight gravity going round corners – the effect is gonna get a heck of a lot stronger so get practising now or else. With all these hills, bumps, and bends you're in for a

▼ Pedal to the metal and burn rubber, but watch out it's a rocky ride!



amiga

We hope to review the Amiga game next month.

update

## PRESENTATION 94%

25 circuits spread over 5 courses with 12 characters to choose from and all in one load – need we say more?

## GRAPHICS 94%

Fast flowing, well detailed and varied graphics with a solid 3-D road effect and highly effective illusion of riding over hills.

## SOUND 78%

The few effects that are present are well done with a good tune to accompany the racing action.

## HOOKABILITY 94%

From the moment you press the fire button any doubts are swept away with the dust churned up at the starting line.

## LASTABILITY 92%

The gameplay can get a little too familiar with prolonged play, but no course is ever the same to play or see, and the game always provides a very strong challenge.

## OVERALL 94%

Superlative, high-speed, off-road action, setting the incredibly fast pace for the rest to follow this Xmas.

# RVF

**HONDA**

MicroStyle, Amiga £24.99

**A**s a novice you begin your motorcycling career riding your 750cc Honda RVF around lesser-known British circuits in the Clubman Championship. Before each race, you can practice riding around the track, trying to get the best qualifying time to claim pole position.

Viewing the high-speed action from just behind your bike, you must try to avoid oil patches and bumps on the track which can cause the bike to slide to a screeching halt. Collision with the obstacles bordering the track sends the rider flying into the air. Miraculously, no matter how bad the crash, the rider gets up and push-starts the bike – waggle the joystick to make him run!

Only after winning the Clubman and then the National

Championship are you allowed to compete on international circuits in a bid to become World Champion.

Two players can also compete against each other by linking two Amigas, or an Amiga and a ST together with a home-made connection lead!



▲ That's you – leaning into the corner ahead.



Despite coming with a hefty manual, and being on the MicroStyle 'Games For Adults' label, RVF is surprisingly simplistic. All you do is race around track after track – there are no deep simulation aspects here. However, if fast action is what you want RVF delivers it in style with the fast-scrolling track and realistic engine noises giving an exhilarating feeling of high speed.



Although technically very good RVF lacks any depth or variety. Fun at first, racing around the many tracks soon gets repetitive. I'm not convinced the action is that realistic either – the rider can lean right over at extremely slow speeds without falling off! Still, RVF will keep bike fans happy for a while.

**PRESENTATION 79%**  
Good manual packed with real-life racing info, not that many game options.

**GRAPHICS 85%**  
Very fast scrolling.

**SOUND 75%**  
Realistic engine noises.

**HOOKABILITY 80%**  
Fast action initially impresses...

**LASTABILITY 65%**  
...but lack of depth leads to repetitiveness.

**OVERALL 70%**  
A playable but uncomplicated racing game.

# 3D POOL

Firebird, Amiga £19.99

**P**ool is one of those distinctly unathletic games that people play in pubs – perhaps that's why the ZZAP! team like it so much!

Remember the 64 version of 3D Pool? It was reviewed in Issue 52, getting a respectable 74%. The method of shot selection in the 16-bit version is largely unchanged: you have no cue – instead you rotate the table to aim your shot.

The one alteration is that here

the mouse is used to select icons to rotate, tilt, and zoom into/out of the table and to select shot power and spin. Alternatively, these functions can be accessed by pressing either or both mouse buttons and a direction.

Play options include a tournament with eight computer opponents (including European pool champion 'Maltese' Joe Barbara), a two-player game, and trick shot play with its own shot editor.

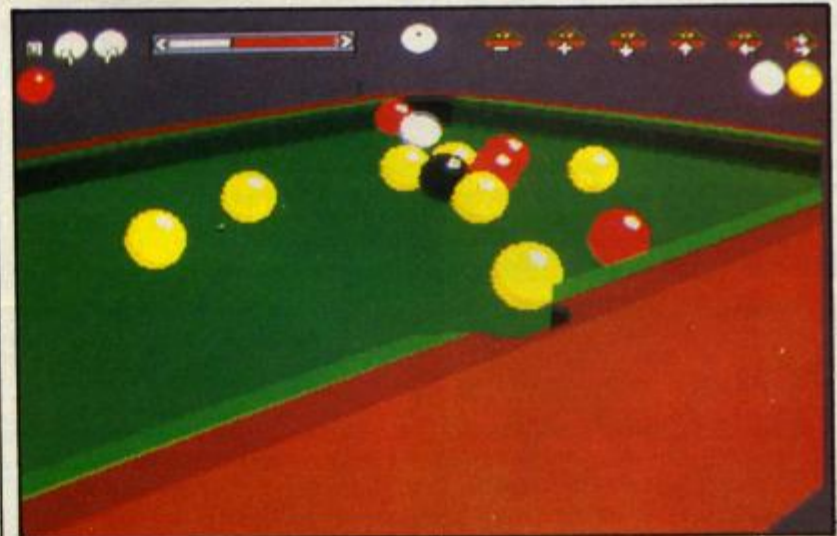

▲ The only thing missing is the money for the next game on the side of the table!



While playing the real thing is best, this is a good sim which allows you to view the table from more angles than real life (unless you climb on tables!). As with real life, waiting for someone (ie Phil) who takes ages to line up their shot can be irritating, but that's part of the game. Fortunately the computer players are quite fast, but not as much fun to play. In short if you're a pool fan get this, if not it's still very much worth a look.



More detailed solid graphics allow the 3-D perspective to be more accurate than in the 64 version. Another improvement is that the computer players take less time to take their shots. Mouse control also speeds up play, allowing you to zip round the table faster than Alex Higgins! This is a playable, well programmed pool sim – it's just like being down the pub (well almost!).

**PRESENTATION 80%**  
Good array of options.

**GRAPHICS 76%**  
Effective solid 3-D.

**SOUND 40%**  
Ball 'clicks' and pathetic applause.

**HOOKABILITY 75%**  
The rules of pool are easy to understand.

**LASTABILITY 80%**  
Eight opponents provide a lasting challenge.

**OVERALL 78%**  
A first-rate pool sim.

# 520ST-FM SUPER PACK

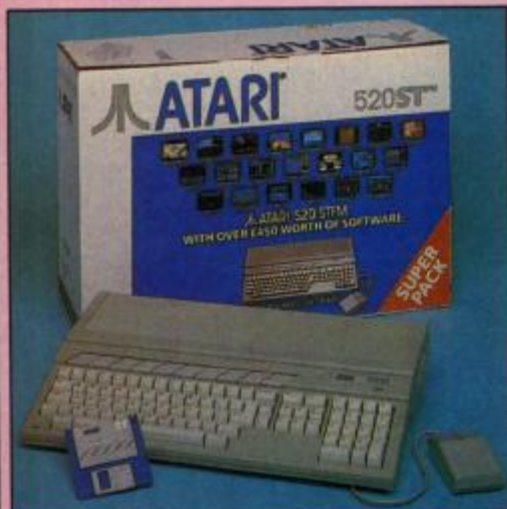

**1Mb DISK DRIVE  
£450 OF SOFTWARE**

### ARCADE GAMES

Arkanoid II	Imagine	£19.95
Beyond The Ice Palace	Elite	£19.95
Black Lamp	Firebird	£19.95
Buggy Boy	Elite	£19.95
Chopper X	Mastertronic	£9.99
Ikari Warriors	Elite	£14.95
Marble Madness	Electronic Arts	£24.95
Quadralien	Logotron	£19.95
Ranarama	Hewson Consultants	£19.95
Return To Genesis	Firebird	£19.95
Roadwars	Melbourne House	£19.95
Starquake	Mandarin	£19.95
Test Drive	Electronic Arts	£24.95
Thrust	Firebird	£9.95
Thundercats	Elite	£19.95
Wizball	Ocean	£19.95
Xenon	Melbourne House	£19.95
Zynaps	Hewson Consultants	£19.95

### SPORTS SIMULATIONS

Eddie Edwards Super Ski	Elite	£19.95
Seconds Out	Tynesoft	£19.95
Summer Olympiad '88	Tynesoft	£19.95

### PRODUCTIVITY SOFTWARE

Organiser	Triangle Publishing	£49.95
-----------	---------------------	--------

### JOYSTICK

Atari CX40 Joystick	Atari Corp	£4.99
---------------------	------------	-------

**FREE ATARI BUNDLE VALUE: £458.97**

The Atari Super Pack is ideal for you if you want to get off to a flying start with the best in entertainment software. The Pack includes a 520ST-FM with 1Mb RAM, a built-in 1Mb disk drive, over £450 of top games and a joystick. If you buy the Super Pack at Silica Shop, we will add our own ST Starter Kit (worth over £200), Free Of Charge. Return the coupon for details.

# £399

INCLUDING VAT

With SM124 mono monitor: £498 INC VAT

With SC1224 colour monitor: £698 INC VAT



**ST COMPUTERS**  
The range of Atari ST computers offers something for everyone. From the games enthusiast who wants the challenge of the very best in arcade action, to the businessman who wants to make financial forecasts or faultless presentations. The ST offers high quality graphics, sound and speed for the gamer, whilst providing a fast, user friendly and affordable solution to business. The ST is now firmly established in the home environment and boasts a wealth of users in education, local government, television, and a variety of different businesses. Software for the range stretches to cover applications as diverse as ENTERTAINMENT, ACCOUNTS, ART, COMMUNICATIONS, COMPUTER AIDED DESIGN, DATABASES, DESKTOP PUBLISHING, EDUCATION, MUSIC, PROGRAMMING, SPREADSHEETS, WORD PROCESSING and more. For a full list of the software available, as well as details of the ST range, complete and return the coupon below.

All prices correct at the time of going to press. E&OE

# 520ST-FM EXPLORER PACK

WITH BUILT-IN 1Mb DISK DRIVE



The value for money offered by the Atari ST range is reflected in the Explorer Pack featuring the 520ST-FM computer with 512K RAM. The 520ST-FM computer now comes with a built-in 1 Mb double sided disk drive as well as a free mouse controller and a built-in TV modulator. The new 520ST-FM Explorer Pack includes the 520ST-FM computer, the arcade game Ranarama, a tutorial program and some useful desktop accessories. In addition, if you buy the Explorer Pack from Silica, we will give you the Silica ST Starter Kit worth over £200, FREE OF CHARGE. Return the coupon for details of our Starter Kit and of the full ST range.

# £260

ONLY £2.51 PER WEEK  
RETURN COUPON FOR DETAILS  
+VAT= £299

+ SM124 mono monitor: £398 INC VAT

+ SC1224 colour monitor: £598 INC VAT

# WHY SILICA SHOP?

Before you decide when to buy your new Atari ST computer, we suggest you consider very carefully WHERE you buy it. There are MANY companies who can offer you a computer, a few peripherals and the top ten selling titles. There are FEWER companies who can offer a wide range of products for your computer and expert advice and help when you need it. There is ONLY ONE company who can provide the largest range of Atari ST related products in the UK, a full time Atari ST specialist technical helpline and in-depth after sales support, including free newsletters and brochures delivered to your door for as long as you require after you purchase your computer. That one company is Silica Shop. We have been established in the home computer field for ten years with an annual turnover in excess of £8 million and can now claim to meet our customers requirements with an accuracy and understanding which is second to none. But don't just take our word for it. Complete and return the coupon below for our latest literature and begin to experience the Silica Shop specialist Atari service.

**SILICA STARTER KIT:** Worth over £200, FREE with every Atari ST computer bought from Silica.

**PROFESSIONAL PACK:** Free business software with 1040ST-FM and MEGA ST's bought from Silica.

**DEDICATED SERVICING:** 7 full-time Atari trained staff with years of experience on Atari servicing.

**THE FULL STOCK RANGE:** All of your Atari requirements from one place.

**AFTER SALES SUPPORT:** The staff at Silica are dedicated to help you get the best from your ST.

**FREE CATALOGUES:** Mailed direct to your home as soon as we print them, featuring offers as well as all of the new releases.

**FREE OVERNIGHT DELIVERY:** On all hardware orders shipped within the UK mainland.

**PRICE MATCH PROMISE:** We will match competitors on a 'same product same price' basis.

**FREE TECHNICAL HELPLINE:** Full time team of Atari technical experts always at your service.

# FREE SILICA STARTER KIT WORTH OVER £200

WITH EVERY ST - RETURN COUPON FOR DETAILS  
ALL PRICES QUOTED INCLUDE FREE UK DELIVERY

# 1040ST-FM PROFESSIONAL PACK

## NOW WITH TV MODULATOR

For the serious home user and the small business, we are pleased to announce a new package based around the 1040ST-FM. The 1040ST-FM has 1Mbyte RAM and a 1Mbyte built-in disk drive. In addition, the 1040ST-FM now comes with a TV modulator built-in. (The previously available 1040ST-F was designed for use with a monitor only and did not come with a modulator.) This modulator allows the 1040ST-F to be plugged directly into any domestic TV set, and comes complete with a lead to allow you to do so. The new 'Professional Pack' from Silica includes the new 1040ST-FM with modulator plus four high quality software packages including a spreadsheet, database, word processor and programming language. This 'Professional Pack' software will enable you to get straight down to business with your new computer. In addition to this software (worth £384.84), if you buy the Professional Pack from Silica Shop, you will also receive the Silica ST Starter Kit (worth over £200), Free Of Charge. Return the coupon for further information.



# £499

INCLUDING VAT

With SM124 mono monitor: £598 INC VAT

With SC1224 colour monitor: £798 INC VAT

ATARI 1040ST-FM	(Computer)	£499.99
VIP PROFESSIONAL	(Spreadsheet)	£149.95
MICROSOFT WRITE	(Word Processor)	£149.95
SUPERBASE PERSONAL	(Database)	£59.95
BASIC DISK & MANUAL	(Language)	£24.98

NORMAL RRP: £884.82  
LESS DISCOUNT: -£385.82  
PROFESSIONAL PACK PRICE: £499.00

# 2Mb & 4Mb MEGA ST

The MEGA ST computers are styled as a lightweight keyboard with a separate CPU, connected by a coiled telephone style cable. There are two versions of the MEGA ST, one with 2Mbytes of RAM and the other with 4Mbytes. Each version has a 1Mbyte double sided disk drive built-in to the CPU unit. The MEGA ST's do not come with modulator built-in and must therefore be used with a monitor. With every MEGA ST purchased, we will add the 'Professional Pack' software (worth £384.83) detailed above, plus the Silica ST Starter Kit (worth over £200) both Free Of Charge. Return the coupon for further details.



**2Mb MEGA ST**  
**£899** INC VAT  
+ mono monitor = £998  
+ colour monitor = £1198

**4Mb MEGA ST**  
**£1199** INC VAT  
+ mono monitor = £1298  
+ colour monitor = £1498

# DTP PageStream £149 +VAT =£171.35

Desktop Publishing (DTP) is one of the fastest growing applications for personal computers. We are pleased to announce a powerful low cost package for the Atari ST called PageStream. PageStream costs only £149 (+VAT=£171.35) and, because it works with an Atari 1040ST and a Selkosh SP-180A printer, you can be up and running with a complete system for less than £1000. Some of the features of PageStream are listed to the right. If you would like further information on this program, complete and return the coupon below, ticking the 'DTP' box in the corner.

- TEXT-FLOW AROUND GRAPHICS
- ROTATION OF TEXT & GRAPHICS
- SLANT OR TWIST ANY OBJECT
- POSTSCRIPT COMPATIBLE
- TAG FUNCTION
- AUTO/MANUAL KERNING & HYPHENATION
- GROUPING OF OBJECTS

# DO YOU OWN AN ATARI ST?

If you already own an Atari ST computer and would like to be registered on our mailing list as an ST user, let us know. We will be pleased to send you copies of our price lists and newsletters FREE OF CHARGE as they become available. Complete the coupon and return it to our Sidcup branch and begin experiencing a specialist ST service that is second to none.

**SILICA SHOP:**

**SIDCUP (& Mail Order)** ..... 01-309 1111  
1-4 The Mews, Hatherley Road, Sidcup, Kent, DA14 4DX  
OPEN: MON-SAT 9am - 5.30pm LATE NIGHT: FRIDAY 9am - 7pm

**LONDON** ..... 01-580 4000  
52 Tottenham Court Road, London, W1P 0BA  
OPEN: MON-SAT 9.30am - 6.00pm LATE NIGHT: NONE

**LONDON** ..... 01-629 1234 ext 3914  
Selfridges (1st floor), Oxford Street, London, W1A 1AB  
OPEN: MON-SAT 9am - 6.00pm LATE NIGHT: THURSDAY 9am - 8pm

To: Silica Shop Ltd, GAMCH01189, 1-4 The Mews, Hatherley Road, Sidcup, Kent, DA14 4DX  
**PLEASE SEND FREE LITERATURE ON THE ATARI ST**

Mr/Mrs/Ms: ..... Initials: ..... Surname: .....

Address: .....

Postcode: .....

Do you already own a computer  
If so, which one do you own? .....

DTP





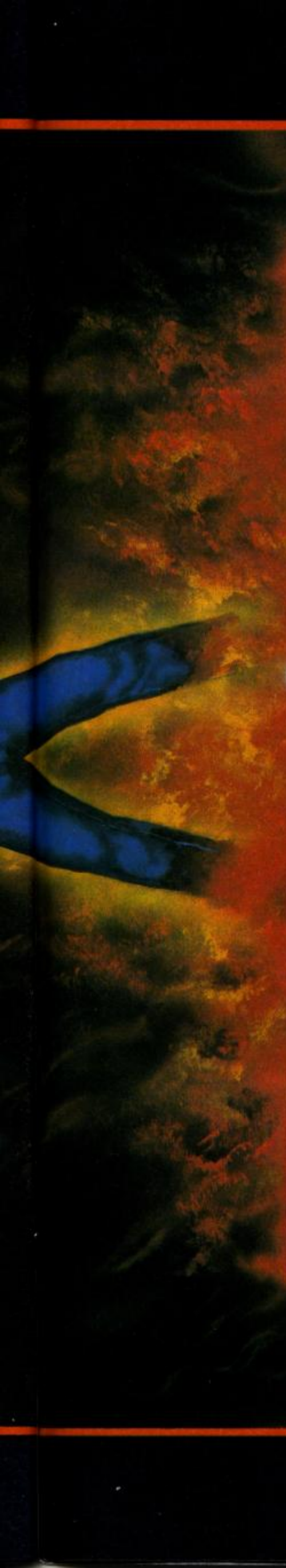

# ATARI

## HISTORY IN THE MAKING

Actual C.64 Screenshots

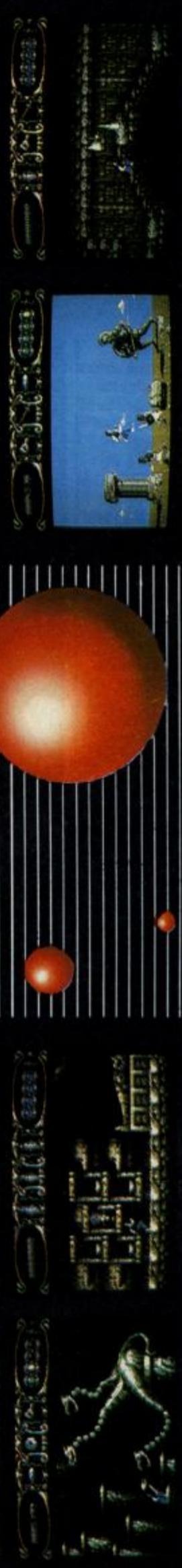

S Y S T E M . 3

SYSTEM 3 SOFTWARE, BLENHEIM HOUSE, 1 ASH HILL DRIVE, PINNER, MIDDLESEX HA5 2AG  
 Telephone: 01 866 5692 FAX: 01 866 8584

AVAILABLE ON SPECTRUM AMSTRAD CPC C.64 AMIGA ATARI ST

# PRO TENNIS TOUR

4

Ubi Soft, Amiga £24.99

**T**here are several things you need for a good game of tennis: a glorious summer afternoon, a good court to play on, a racket (so stick some Alice Cooper on your ghettoblaster!), and balls (the less said here, the better!). And in between games, you'll need a cool, refreshing drink (sod the barley water, get out the XXXX!).

Finally, you'll need an opponent who likes loud music and lager, and who is also supremely fit – not an easy task! So instead, why not stay indoors like all good armchair sportspeople, and play Pro Tennis Tour, a tennis simulation from French software house, Ubi Soft?

You can play either against the computer (there are three skill levels) or another lager-loving headbanger on a court viewed from the usual TV angle (from above and behind one of the players). A novel technique is used to control the direction of shots (including the serve). As you are about to hit the ball, a yellow cross appears on the court – this must be positioned where you want the ball to go. When a particularly brilliant winning shot is played, the replay mode shows the entire rally on a spinning miniature 3-D court!

The cross also indicates to your opponent where to stand to return your shot. This sounds terribly easy, but with the blis-



I'm always an avid watcher of Wimbledon – the tennis, silly, not the football team! So I couldn't wait to get my hands on Pro Tennis Tour. Ubi Soft aren't renowned for sports sims, but if this is anything to go by I hope they do many more. Pro Tennis Tour is definitely the most realistic tennis game I've seen, played at a frenetic pace that leaves you literally gasping! The difficulty of hitting the ball is disconcerting at first, but once mastered the novel hitting technique works really well. And when you do hit a really good shot, you're rewarded with a mind-blowingly brilliant 3-D replay. Great stuff!

▼ Bad start! Cam's already lost the first point in his service game.

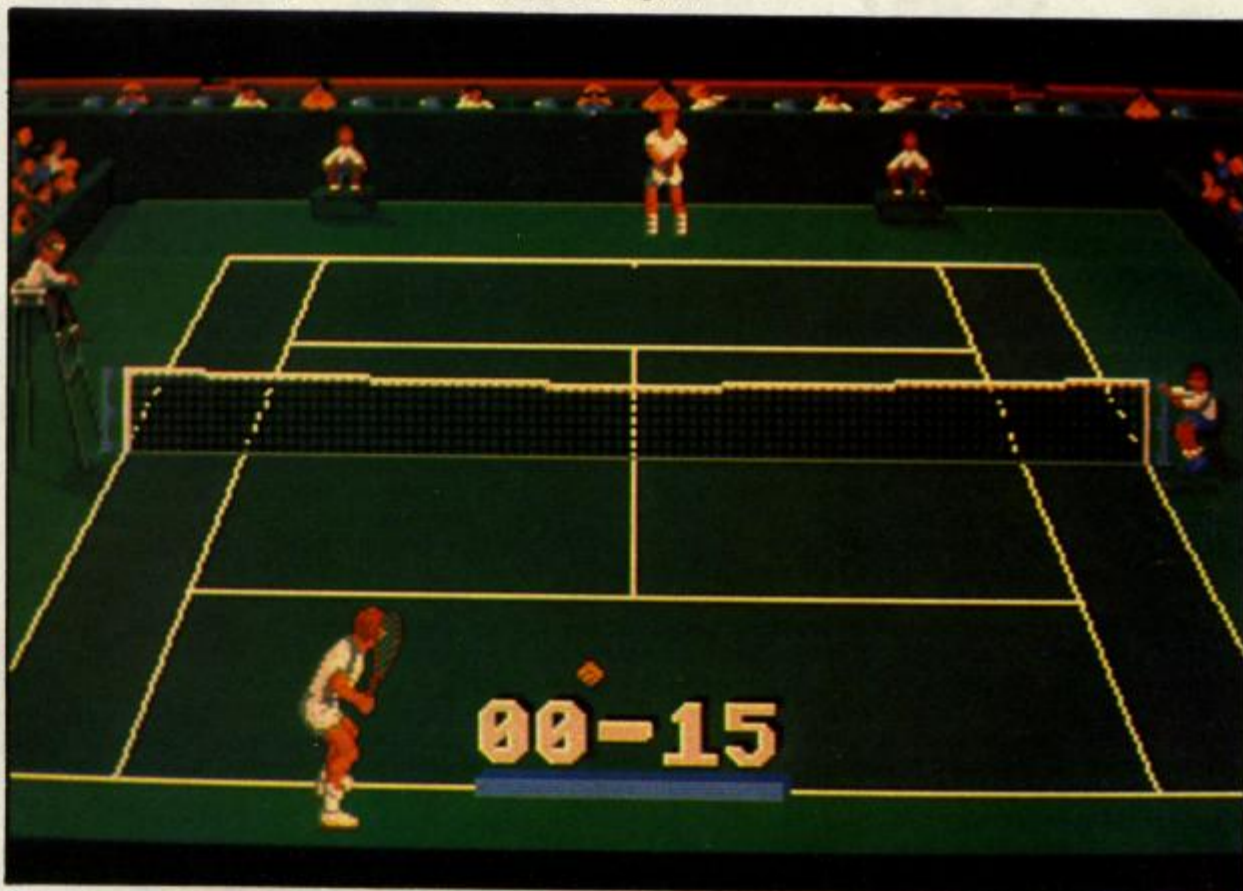

▲ The training machine sends out an endless stream of balls.



Pro Tennis Tour is beautifully presented with a well laid-out court, good animation of the players, and a vast array of options. But even after hours of practice I still found it difficult to hit the ball. Even so, the 'aim the cross' hitting technique makes a refreshing change from previous tennis sims and allows you to play the ball exactly where you want, if you can time it right! With fast realistic action, cheering crowds, and a superb replay mode, Pro Tennis Tour has a wonderful Centre Court atmosphere – so good in fact that I've been able to sell strawberries and cream to the rest of the ZZAP! team at extortionate prices!

tering pace at which the game is played, such a simple task becomes very tricky. So to help budding Boris Beckers, the game includes a training machine which can be programmed to churn out balls in six different patterns. There's also a special practice option for serving.

When you think you can hit the ball more often than not, it's time

to take on the computer players in the four Grand Slam tennis tournaments, played at the world's most famous venues: Melbourne, Paris, Wimbledon, and Flushing Meadow. Starting off at 64th in the world, you can improve your ranking by winning matches. And as it's likely to take a long time to get to No.1, there's a useful save facility.

64

64 owners shouldn't have to wait too long for their own version, priced £9.99 cassette, £14.99 disk.

update

### PRESENTATION 91%

Plenty of practice and play options. Invaluable save facility.

### GRAPHICS 85%

Good 3-D perspective, well animated sprites, and excellent replay mode.

### SOUND 78%

Unremarkable music, but atmospheric samples.

### HOOKABILITY 80%

A lot of fun, although hitting the ball initially difficult.

### LASTABILITY 91%

Once the hitting technique is mastered, the desire to beat the tough computer opponents should keep you playing for a long time.

**OVERALL 88%**

Undoubtedly the best tennis sim yet.

# Beach Volley

Ocean, Amiga £24.95

One of London's top two-man volleyball teams has been offered the opportunity of a lifetime: a free trip around the world. The only catch is that they must beat the host country's top team to be allowed to progress to the next. The first contest is in London, with the Houses of Parliament in the background, and Royal Guardsmen acting as the scorers. There are eight countries to visit in all, including America, Russia, Egypt and France. Each country has different back-

grounds, tougher gameplay and a hilarious intro-sequence showing the two men arriving in the country. Alternatively two human players can battle it out in London.

The rules of volleyball are fairly simple. A point is scored by making the ball land inside your opponent's half of the court, but only if you're serving. If not, you win serve, and the opportunity to score points. Once the ball crosses over the net it can be touched only twice before being returned. To win the game you must score seven points with a lead of two points. In the computer game there's also a time limit, indicated by a rock jingle



ROBIN

Yeah, Beach Volley! Now we're talking sun, beach bombshells, and bump, set, spike - roll on the next summer! It may be a little late in the year for a summer sport but what does it matter if it's as playable as this. The typically Gallic, slick presentation really makes the game, with a great sense of humour and cartoon characters. I found the gameplay a shade simple, with not all that many moves to hand, and there isn't that much variety despite the changing backdrops and funny intermission screens. Still, eight levels of increasing difficulty make a good challenge with plenty of red-hot playability.

which starts up as time is near to running out.

Actually playing the game is straightforward too. To serve you press fire, throwing the ball up, then press fire again to hit the ball. As the ball crosses the net the screen pans to follow it, and when it comes back you're automatically given control of the nearest man. Unless you're blocking a smash (or 'spike' in

volleyball-ese), your first move will simply to keep the ball in the air, allowing you to manoeuvre into position to hit it back. To begin with simply keeping the ball aloft will be enough to keep you occupied, but the more the play the more moves and tactics become apparent. It's perfectly possible to aim the ball as you hit it, but getting the knack takes practice.

▼ The blue cross shows where the ball will land.



STEVE

Brilliant! All the fun of the real thing but without the risk of sunburn and getting sand in your shorts! The basic game is simple, but hard to master, making for great addictivity. To begin with, the way the screen pans can be a bit irritating, but you soon get used to it and the competitive action in two-player mode is immense. But even in one player mode, the sheer playability and great cartoony sprites make for a highly enjoyable game. A touch pricey perhaps, but otherwise highly recommended.

▼ Yeah! Scoring with a 'spike' in Egypt.

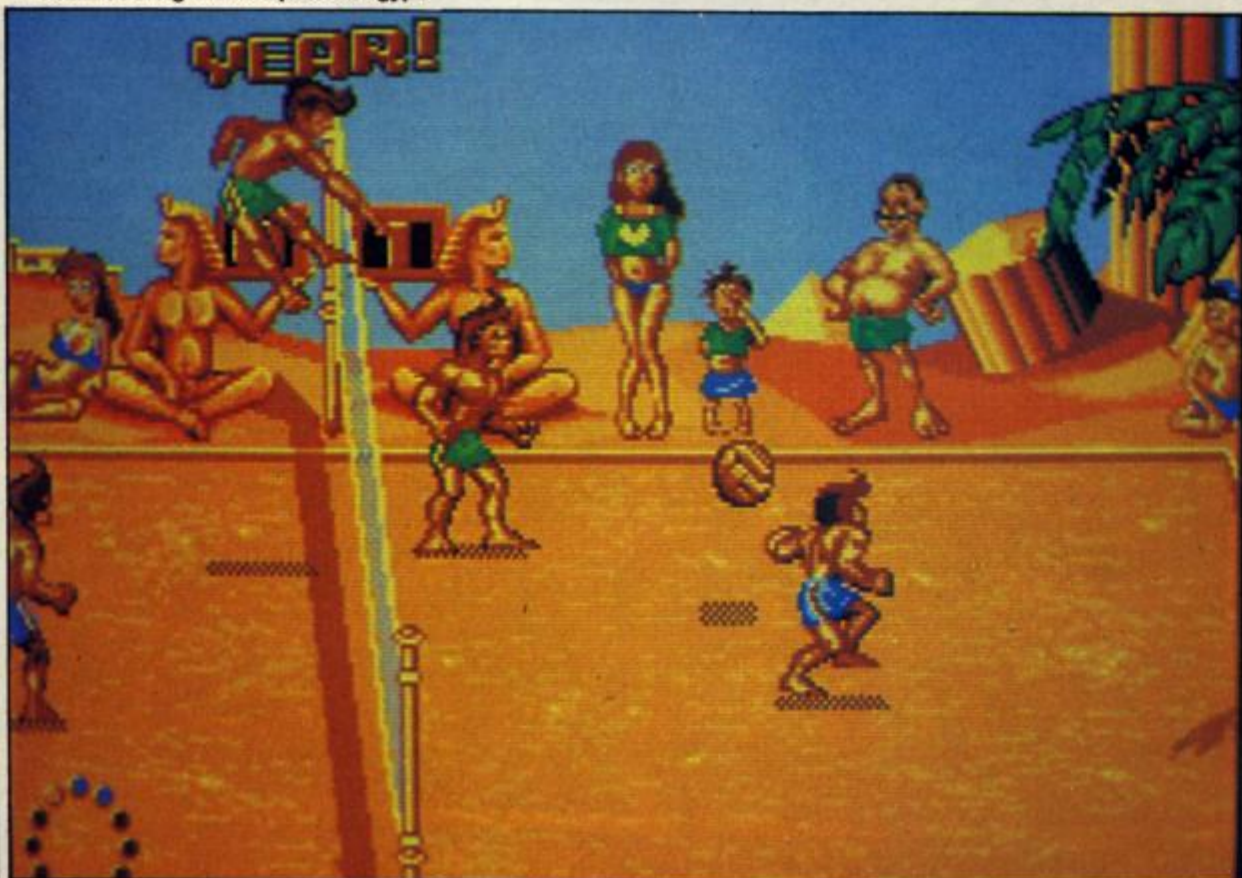

64

A C64 version is in production and should be great!

update

### PRESENTATION 90%

Great intro and humorous intro screens really add to the atmosphere of the game.

### GRAPHICS 85%

Excellent cartoony main sprites, but the backgrounds could've been better.

### SOUND 87%

Sampled speech and some good rock'n'roll tunes.

### HOOKABILITY 89%

Incredible, it's just so much fun...

### LASTABILITY 84%

... a Kick-Off-style tournament would've been good, but there are a lot of tough levels in one-player mode.

**OVERALL**  
**85%**

One of the most fun sports sims around.

# THE UNTOUCHABLES

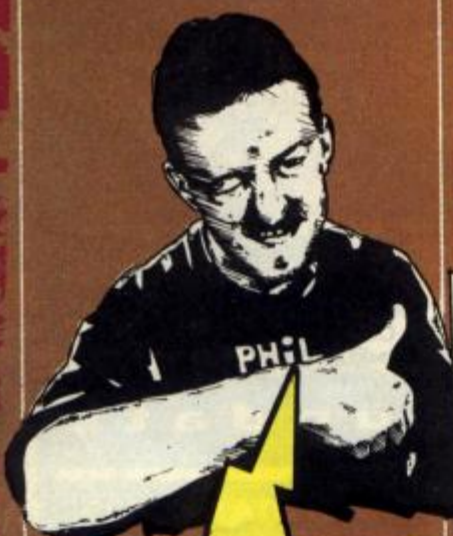

If you thought the film was great to look at, be assured the game is even better. The graphic detail in the game is excellent; from the way the hood's jacket flutters when he's shot on level six, to how Ness reloads his shotgun in the alley. The ragtime tunes which accompany the levels are superb too, they really get you into the mood of the times even if, like me, you usually prefer Alice Cooper! Just a few of the levels would make a great game, but six of them together makes an unbelievable package. The John Meegans/Steve Thompson **RoboCop** team have come up with a real blockbuster.

Ocean, C64 £9.99 cassette, £14.99 disk.



●Chicago, Chicago, it's my sort of town!

**H**ard times in Chicago, the Great Depression has made many unemployed, and most feel the need of a good stiff drink. Of course, that's been banned by the Prohibition but in secret bars – speakeasies – the Mob offers booze at a vast profit. And one of the best sources of alcohol is Canada, just across the Great Lakes which Chicago overlooks. During winter many amateur bootleggers race their cars right across the frozen lakes. Professionals just bribe poorly paid customs officials, and their alcohol makes gangsters like Al Capone incredibly wealthy. By 1926 Chicago's police is thoroughly corrupt . . .

Eliot Ness is the FBI agent sent to clean up the Windy City. His first action is a raid on a

warehouse suspected of holding alcohol. Of course one of the policemen snitches to the crooks beforehand so there's no booze, just lots of heavily armed hoods. The warehouse level has multi-directional scrolling, and besides blasting normal crooks you can track down the white suited ones who carry useful evidence. If you shoot one a piece of evidence is dropped, collect ten and you finish the section. But as most of the time you're jumping up stacks of crates it isn't easy – when the evidence falls all the way down it's easy for another crook to grab it first! Also to be looked out for are violin cases (containing very useful machine guns) and roses (to restore energy).

After being betrayed once, Ness swiftly assembles the

incorruptible 'untouchables' to help him with his task. The Italian Stone is a crackshot, Malone (Sean Connery) is a wise old cop and Wallace is the accountant. Together this improbable quartet set a trap at a bridge across the US-Canadian border. As soon as the bootleggers arrive a massive shoot-out starts. Ness opens fire first, lying prone on the ground with a rifle. Using a telescopic sight he must pick off the bootleggers as they shoot back from the cover of trucks and cars. If things get a bit hot Ness can roll left or right, making the screen scroll with him. Roll over the edge of the screen and you can swap Ness for one of the other characters – useful if energy is low, but some are slower and less accurate than others.

Success here gives Ness vital documents which he needs Capone's accountant to decipher. Capone promptly has

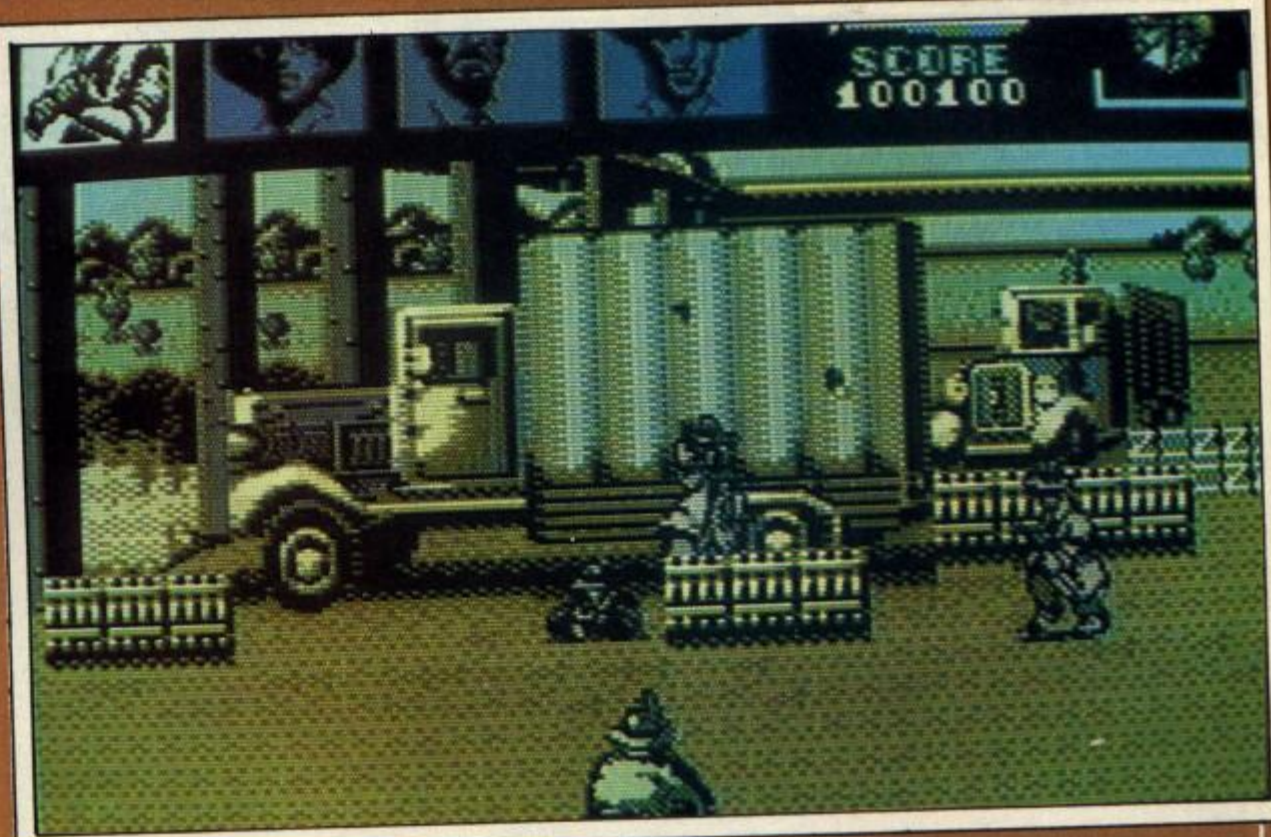

▲ The second level bridge scene. Use the telescopic sight (top-right) for a more accurate aim.

# THE UNTOUCHABLES

TM

▼ Level three, the alley scene. Blast the gangsters with your double-barrelled shotgun.



the accountant sent to a railway station to get him out of the city. While racing to intercept the accountant there the Untouchables are ambushed themselves. Load three, the Alley Scene, begins with Ness hiding behind a wall. If he moves to the left the screen flicks to show the alley with mobsters moving forward, guns blazing, and cars driving past. You move a cursor to blast them, but your double-barrelled shotgun can only fire twice before it's time to pop back into hiding to reload. Once again you can flick between the



More ways of killing someone with a gun have yet to be discovered. This really is a spectacular combat game, or games, as there's six of them. Yet despite the wide variety of game-styles the game holds together well with great newspaper headlines between levels. Unlike **Batman** if you lose all your lives you don't have to go all the way back to level one, which is a relief in such a massive game. My favourite stages are probably levels one and four, but all the levels are first class. And what's more the music is brilliant: using a variety of famous period tunes for the levels, Jonathan Dunn has added a great deal of atmosphere to an utterly superb game.



## Test

characters. Blast your way through the alleys and it's on to the train station.

This downward scrolling, overhead-view section has Ness moving down stairs, blasting villains, while taking care not to hit civilians. There's also a pram which Ness must move around to make sure it doesn't hit anything, spilling out the baby and leading to the squad's demise in a flash of bad publicity!

At the bottom of the stairs one of the hoods holds the accountant hostage with a gun to his head. In this first-person perspective section you have to blast the hood and not the accountant. Originally quite gory, complaints from a chain store mean there's not so much blood now!

With the help of the accountant Capone is put away, not for murder but tax evasion! During the trial, one of Capone's hood

runs out and is pursued by Ness to the roof of a building. This is a 3-D sequence a bit similar to the alley scene, Ness has to keep shooting the hood backwards until he falls off the building.

▼ Be careful where you shoot – you mustn't hurt the hostage.



▼ The final scene: it's do or die as you come up against one of Capone's hoodlums.



No wonder **The Untouchables** has taken this long to come out. The programmers haven't decided to go for masses of screens based around one type of game but like **Batman** have gone for true variety of play. Each section is a game in itself with its own style of presentation, demands and tactics required to get through. The scenes are well held together by a strong movie-style progression with a gradual difficulty increase, while the atmosphere is superb with a lot of grey colour to set the scene. I particularly like the way the cursor is used to move Eliot round alley corners to reload. Watch also for the excellent graphic of Nitty falling to the floor in the final scene.

Individually the scenes aren't that original but brought together they offer great variety and long-lasting appeal. Throw in some superb loading screens between levels and you have a great VFM program. Well worth the wait.

amiga

Special FX should be finishing the Amiga game soon.

update

### PRESENTATION 97%

Great newspaper reports between levels. Disk owners will have superb end-of-level static screens.

### GRAPHICS 95%

Colourful, well-drawn and a stunning attention to detail.

### SOUND 97%

Superlative period tunes really help make the game.

### HOOKABILITY 95%

Instantly playable.

### LASTABILITY 97%

Six different games, all of them challenging in their own right.

**OVERALL  
96%**

Enough arcade action to put most compilations to shame!

# The PREVIEWS

Brought to you from a Greek jail by the mystery Swansea City supporter

## THALAMUS

Thalamus have been resting on their laurels since the runaway success of *Armalyte*, releasing only 'The Hits' compilation for the C64. But Xmas always tends to bring software houses out of hibernation, and sure enough Thalamus have plenty of games lined up for your Christmas stocking.

### THE SEARCH FOR SHARLA

This is a novel approach for normally arcade orientated Thalamus. Set in a *Lords of Midnight*-style world, using landscaping techniques, *Sharla's* play area is made up of twelve moons, each moon having individual landscapes, caverns, dungeons and quests. There are an incredible 512 interactive characters walking around under a sky which slowly moves between night and day.

Written by Esprit Software, *Sharla's* release date hasn't been set yet (most likely early next year) but if it delivers all it promises then it should be the one game all us veterans of the Mike Singleton games are waiting for. (£9.99 cassette/£12.99 disk with an Amiga version planned).



▲ Thalamus's incredibly deep C64 graphic adventure *Sharla*.

### RETROGRADE

An unknown quantity at the moment, *Retrograde* sees the return of shoot-'em-up action, and was developed for Apex Software by John Rowlands. The *Retrograde* is a bounty hunter out for riches in enemy territory. Diamond crystals are the prizes at stake and fat juicy planets are the targets for all out destruction.

With eight levels combining horizontal and vertical scrolling, *Retrograde* has some pretty weird things going on – mutant aliens become clones of the hero, and puffer fish spit lasers! Swipe a power crystal from their roasted carcasses to boost your cash counter and buy weapons from shops on the surface of planets to really stir up some serious hell.

Find 500 worth of cash and you can search for a unique alien. Kill him and activate the planet detonator – one blown planet later and you're off to the next one. Easy? No way, squire!

No release dates yet for *Retrograde* (£9.99 cassette, £12.99 disk).

### SNARE

For those of you with more brains than brawn, Thalamus have just the thing – *Snare*.

It's maze time again, in a somewhat similar style to the ball-rolling *Quedex*, but this time the playfield is the *Snare* – a 16-element temporal cavity (in future millionaire André Thelman's garden no less).

A well armed hover ship is the main hero of the puzzle/arcade action. Pressure plates and tiles dictate where to go, but so too do the guardian robots patrolling the *Snare*. The maze has been turned into a prime time TV game show with contestants trying avoid void pits, leaping on speed-up 'turbo tiles' and using transporters to zip around the *Snare*.

And guess who's the only person who knows the route through the *Snare*? Yep, André Thelman and he's very dead now, so time to use your brain with a fair dose of fire button pumping.

An October release date has been pencilled in and should be available by the time you read this (£9.99 cassette/£12.99 disk)



▲ Mind-bending action with C64 *Snare*, lots of puzzles with snap 90° turns.

▼ Collect the dosh, avoid the puffer fish and blow up the planet in C64 *Retrograde*.



**MARVEL<sup>®</sup>  
COMICS**

**MARVEL COMICS<sup>®</sup> & PARAGON SOFTWARE<sup>®</sup>  
PRESENT**



**the AMAZING<sup>®</sup>  
SPIDER-MAN<sup>®</sup>** **and** **CAPTAIN<sup>®</sup>  
AMERICA<sup>®</sup>**  
**IN**







Screenshots taken from www.compt...

Free Marvel comic book destined to become a collector's item, available by return.

# DR. DOOM'S REVENGE!



Available for SPECTRUM, AMSTRAD, C64, AMIGA, ATARI ST, PC and Compatibles.

EMPIRE SOFTWARE · 4 THE STANNETTS · LAINDON NORTH TRADE CENTRE  
BASILDON · ESSEX · SS15 6DJ · PHONE (0268) 541126

Copyright © by Marvel Entertainment Group, Inc. All Rights Reserved. Marvel, Spider-Man, Captain America, Dr. Doom and the distinctive likenesses thereof are trademarks of the Marvel Entertainment Group, Inc. and are used with their permission. The AMAZING SPIDER-MAN AND CAPTAIN AMERICA IN DR. DOOM'S REVENGE is produced under license from the Marvel Entertainment Group.

# ocean

On a cold, dull Thursday, Newsfield ventured up Manchester way for THE Ocean do – a chance to eat the finest food, drink the finest wines (YES Robin – Ed), fight rival journos and take a look at the latest products from Ocean.

▼ One of the Asterix animators produced these fine graphics for Amiga *Ivanhoe*.



On the C64 we saw the incredible *Operation Thunderbolt*. This is looking very nice with graphics by Brian Flannagan and programming by Trevor Brown. According to them the original arcade machine was programmed a bit hurriedly to catch in on the original's success, so they plan to make their conversion superior to the arcade game!

The scenario aircraft hijacked, a two-man team is sent to liberate them from the terrorists. You start off in a jeep, rushing through enemy lines toward allied forces, with MIG fighters swooping down on you. As the game progresses you can pick up armour, a laser sight, get aboard a patrol boat and finally get inside the airliner.



▲ Rescue the pilot and you can fly home. (C64 *Operation Thunderbolt*)

▼ Inside one of the superb, horizontally-scrolling levels. (C64 *Operation Thunderbolt*)



# CAPCOM™



## GHOULS 'N' GHOSTS

Take a look at these shots. Aren't they nice? Yep, the next biggie from the Capcom stable is Software Creations' rendition of *Ghouls 'N' Ghosts* (*Ghosts 'N' Goblins 2*, of course). The Capcom game is an astonishing graphics showpiece and Software Creations are approaching the end of the long haul with the conversion – nine months after it was started the C64 game is almost complete.

The basic plot is this. After rescuing his princess once, Arthur is just puckering up to give her a kiss when she's spirited away again! So it's back to battle. This time the quest is set over five levels, and five loads, beginning in a village and running through a ruined city, the clouds, a cavern, and finally the enemy castle.

Baddies to look out for include magicians which turn you into a duck, a Gassinto (a one-eyed cloud) and a Dead Sea monster! In the arcades this was amazing, and we're counting on Software Creations to perform their usual magic with it.

And the magicians are Stephen Ruddy (programming) and Andrew Threlfall (graphics), Aged 21 and 23 respectively they're also responsible for the brilliant *Bubble Bobble* (97%), *LED Storm* (94%), and *Bionic Commandos* (90%). With that sort of pedigree *Ghouls 'N' Ghosts* is sure to be one hell of a platform action game.

Finally, apologies must go to poor Doug Hare for last month's cock-up in the preview of *Myth - lo* was actually written by Doug and not Peter Baron as stated. What can we say but SORRY!

# HIT'EM FOR SIX!

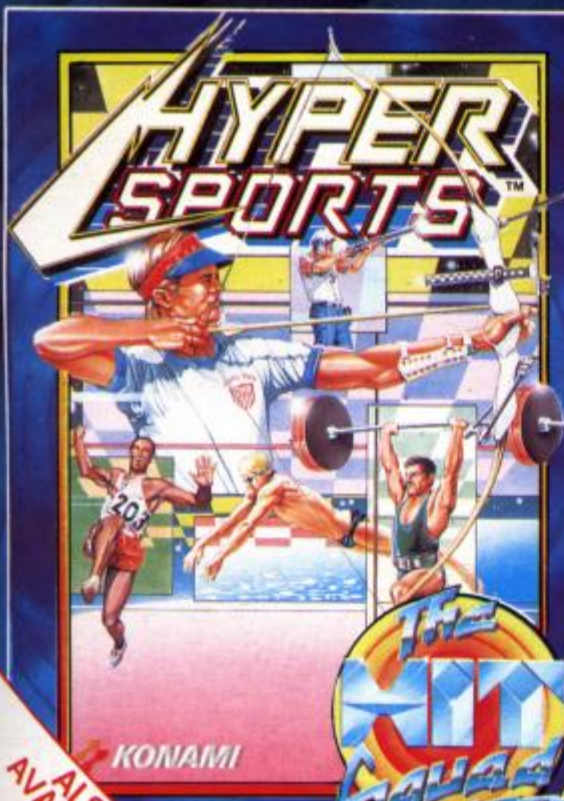

ALSO AVAILABLE FOR BBC

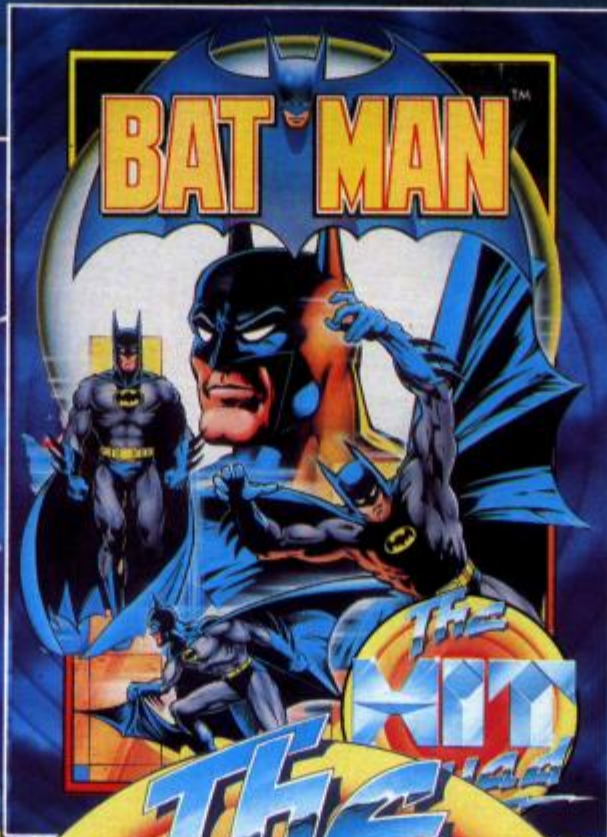

JOYSTICK ONLY

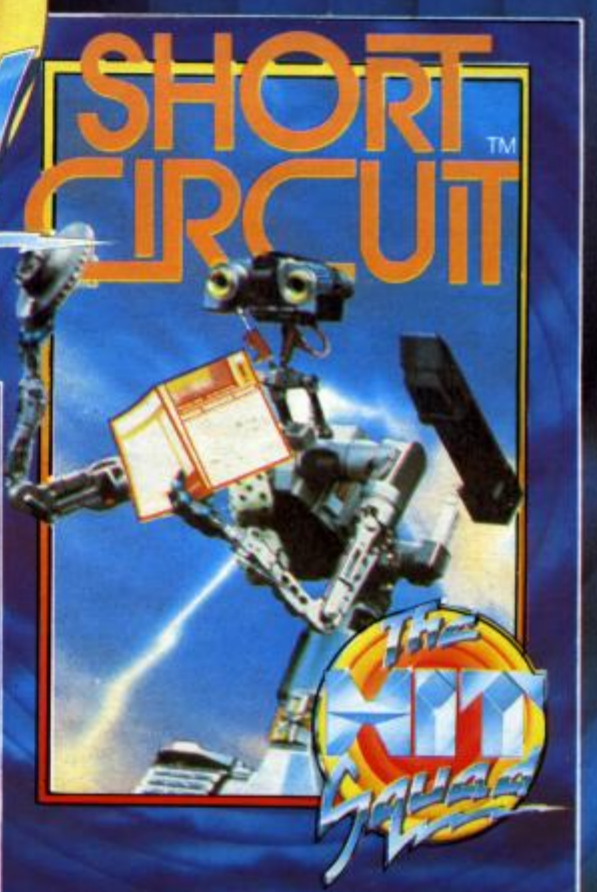

ALL AVAILABLE FOR:  
SPECTRUM  
COMMODORE  
AMSTRAD  
**£2.99 EACH**

**HIT NAMES  
HIT GAMES**



Awaken the beast within you...

# ALTERED BEAST

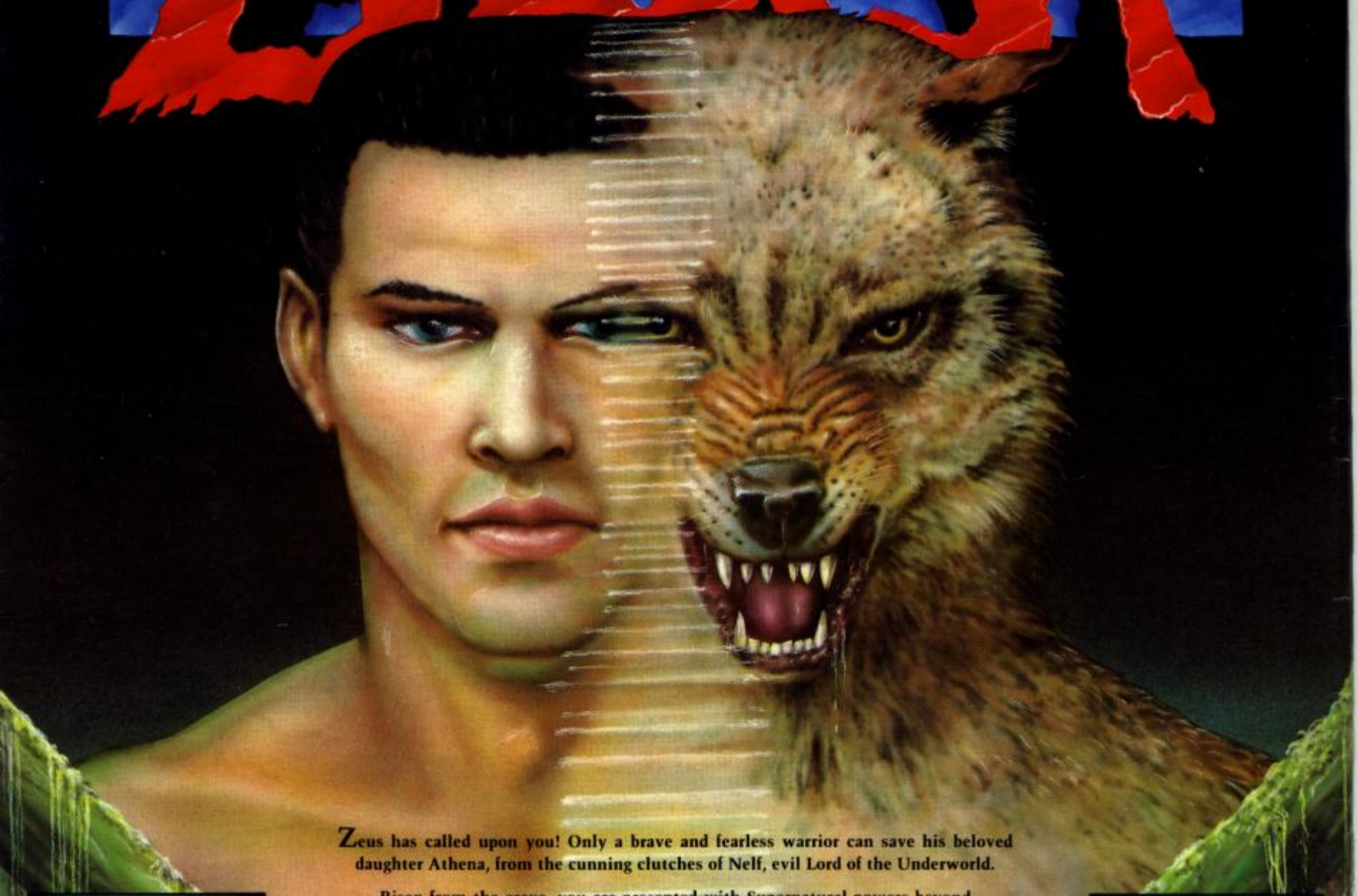

Zeus has called upon you! Only a brave and fearless warrior can save his beloved daughter Athena, from the cunning clutches of Nelf, evil Lord of the Underworld.

Risen from the grave, you are presented with Supernatural powers beyond this world. Collect the 'mystical' spirit balls and transform into an awesome array of creatures – as Strongman, punch and kick harder than ever before, as WereWolf and Were-Tiger rip the flesh of the demons of hell and as Bear, knock out your enemies with one bad breath!

You hear the distant cries of the beautiful Athena and as the terrors of the Underworld tighten their grasp, the beast within you rises to face the final battle!!

ACTIVISION

SEGA



ALTERED BEAST™ and SEGA® are trademarks of SEGA ENTERPRISES LTD. This game has been manufactured under licence from Sega Enterprise Ltd., Japan. ©SEGA 1988, 1989. Marketed and distributed by Activision (UK) Ltd.

Mail Order: Postronix Ltd., Nene Enterprise Centre, Freehold Street, Northampton NN2 6EW. Tel: 0604 791771 (Quote Reference ACT 1). Consumer Enquiries/Technical Support: Tel: 0734 310003

AVIARI ST SCREEN SHOWN