

YAMAHA LSI

YM2413

FM OPERATOR TYPE-LL (OPLL)

APPLICATION MANUAL



YAMAHA

YM2413アプリケーションマニュアル
CATALOG No. : LSI-2424132
1987.9

Table of Contents

I. WHAT IS OPLL?	
I-1. Outline.....	1
I-2. Features.....	1
I-3. Sound Synthesis by FM	1
II. FUNCTIONS	
II-1. Primary Functions.....	2
II-2. Pin Assignmens	3
II-3. Pin Functions	3
II-4. Bus Control	4
II-5. Channels and Slots.....	5
II-6. Block Diagram	5
II-7. Register Map.....	6
III. DESCRIPTION OF OPERATION	
III-1. Registers.....	8
III-2. Phase Generator (PG)	18
III-3. Envelope Generator (EG)	18
III-4. Operator (OP) and DAC.....	19
IV. INTERFACING	
IV-1. Clock Generation	20
IV-2. Audio Output Interface.....	20
IV-3. Interfacing Microprocessor/Microcomputer	21
V. SYNTHESIS OF MUSIC SOUNDS	
V-1. Procedure of Synthesizing Sounds.....	22
V-2. Fundamentals of Sound Synthesis.....	22
V-3. Examples of Sound Synthesis.....	22
V-4. Procedure of Percussion Sound Synthesis	24

VI. ELECTRICAL CHARACTERISTICS	25
VII. TIMING DIAGRAMS	26
VIII. OUTLINE DIMENSIONS	27

I. WHAT IS OPLL?

(I-1) Outline

This LL-Type FM Operator incorporates a DA Converter and a Quartz Oscillator in addition to a YAMAHA original FM Sound Generator, allowing for a much easier and more economical sound generating system assembly than conventional LSIs. Tone data are stored in ROM for software simplicity, making it possible to execute data alterations involved in tone changes with just one Instruments selection operation. Furthermore, a built-in Tone Data Register with capacity to store one tone allows for the generation of sound effects and original tones. Tones applicable to the "CAPTAIN" and TELETEXT are included among built-in tone data.

(I-2) Features

- FM Sound Generator for real sound creation.
- Two selectable modes: 9 simultaneous sounds or 6 melody sounds plus 5 rhythm sounds (different tones can be used together in either case).
- Built-in Instruments data (15 melody tones, 5 rhythm tones, "CAPTAIN" and TELETEXT applicable tones).
- Built-in DA Converter.
- Built-in Quartz Oscillator.
- Built-in Vibrato Oscillator/AM Oscillator.
- TTL Compatible Input.
- Si-Gate NMOS LSI.
- A single 5V power source.

(I-3) Sound Synthesis by FM

This is a method that makes use of harmonics generated by modulation to synthesize musical sounds. Circuitry to realize this method is relatively simple and is capable of generating waveforms including high order harmonics and un-harmonious sounds. It is known that relationships between the modulation index and the spectrum of harmonics are so natural that it is possible to synthesize a wide variety of sounds from natural musical instruments to artificial sounds.

This method is expressed with four parameters as follows.

$$F = A \sin (\omega c t + I \sin \omega m t) \quad (1)$$

Where A is the amplitude of output, I modulation index, ωc and ωm angular frequencies of carrier and modulator respectively. The equation (1) can be expressed alternatively as follows.

$$F = A [J_0(I) \sin \omega c t + J_1(I) (\sin (\omega c + \omega m)t - \sin (\omega c - \omega m)t) + J_2(I) (\sin (\omega c + 2\omega m)t + \sin (\omega c - 2\omega m)t + \dots)] \quad (2)$$

Where $J_n(I)$ is the nth-order Bessel function of the first kind. The amplitude of each harmonic component is expressed as a Bessel function of the modulation index. Sound synthesis by FM is found to be useful to obtain specific musical sounds or sound effects. String sounds, however, cannot be obtained as the distribution of harmonics is not uniform. A method called

'Feedback FM' has been incorporated to solve the problem. This method is characterized by the following equation.

$$F = A \sin (\omega c t + \beta F) \quad (3)$$

Where β is the rate of feedback. The spectrum of harmonics produced by 'feedback FM' has a saw-tooth waveform and therefore it can be used to synthesize string sounds.

Three function blocks, as follows, are needed to realize the above method of sound synthesis by FM.

- a. Phase generator (PG) generating ωt
- b. Envelope generator (EG) generating amplitude A and modulation index (I) which vary with time
- c. sin table (SIN)

The method of sound synthesis by FM can be realized as shown in Figure I-1 with units (operator cells) which combine the three function blocks. By this method, all we have to do is to define a frequency parameter and EG parameters.

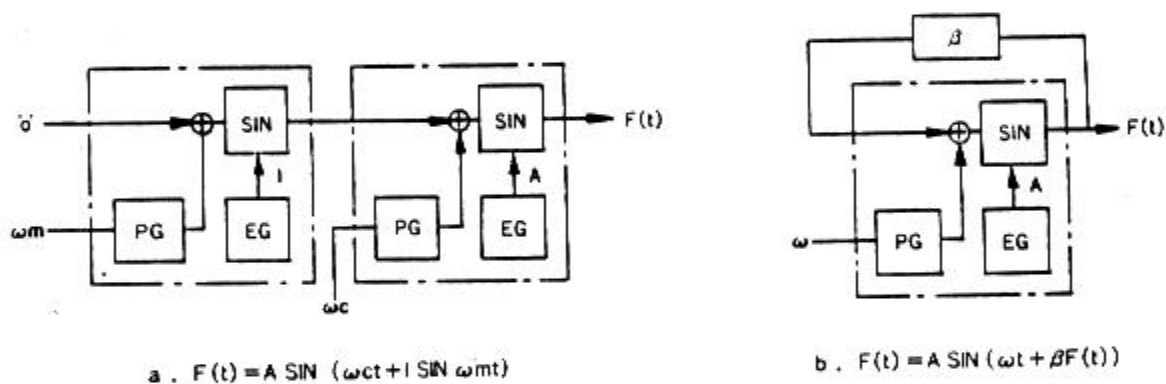

Figure I-1 Sound synthesis by FM with units

II. FUNCTIONS

(II-1) Primary Functions

This OPLL is an FM Sound Generator LSI with a built-in 9-Bit DA Converter. It has two sound generation modes: 9 melody sounds or 6 melody sounds plus 5 rhythm sounds, both allowing for simultaneous generation of different tones. Selection between these two modes can be performed from the software. One of the special features of this LSI is its built-in Instruments ROM. As shown in the table hereunder, this ROM incorporates 15 melody tones and 5 rhythm tones, as well as all tones used for "CAPTAIN" and TELETXT. Furthermore, a built-in Tone Register with capacity to store one tone allows for the creation of sound effects and original sounds. By controlling the parameters of this register (E, ω_1 , I and ω_2 in the equation below), all kinds of harmonics can be created on the basis of the sample wave ω_1 .

$$FM = E \sin (\omega_1 t + I \sin \omega_2 t)$$

Unlike conventional FM sound generators, this OPLL has a built-in Instruments ROM, permitting a substantial simplification of sound generation commands from the processor. First, the desired Instruments code is stored in the Instruments Selection Register. Then, after data has been input at the fixed intervals and timing, the unit starts generating sound. Automatic Processor play can be easily performed by writing data appropriate to the desired music into the Sustain and Volume Registers. For using an original tone, the Instruments Selection Register must be cleared after writing data into the Tone Register as explained above. Rhythm sounds are generated by turning ON or OFF the corresponding bits in the Rhythm Control Register. In this case, the specified data must be input to the Key ON/OFF and F-Number Registers 8CH and 9CH.

(II - 2) Pin Assignment

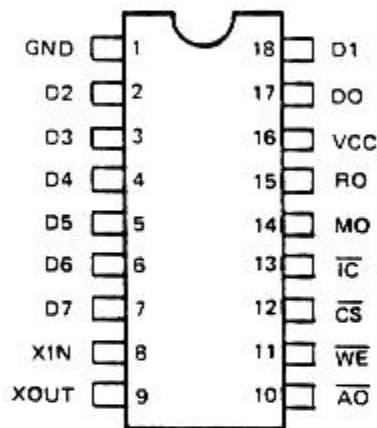

(II - 3) Pin Functions

SYMBOL	I/O	FUNCTION																							
XIN XOUT	I O	A quartz oscillator (3.579545 MHz) is connected between these two pins.																							
D ₀ D ₁ D ₇	I/O	8-Bit Data Bus for OPLL control.																							
A ₀ CS WE	I	<p>For controlling the D₀ ~ D₇ Data Bus.</p> <table border="1"> <thead> <tr> <th>CS</th> <th>WE</th> <th>A₀</th> <th>FUNCTION</th> </tr> </thead> <tbody> <tr> <td>0</td> <td>0</td> <td>0</td> <td>Writes register address into OPLL.</td> </tr> <tr> <td>0</td> <td>0</td> <td>1</td> <td>Writes register contents into OPLL.</td> </tr> <tr> <td>0</td> <td>1</td> <td>0</td> <td>Outputs OPLL test data to D₀, D₁ Pins. Normally not used.</td> </tr> <tr> <td>0</td> <td>1</td> <td>1</td> <td rowspan="2">OPLL Data Bus high impedance</td> </tr> <tr> <td>0</td> <td>x</td> <td>x</td> </tr> </tbody> </table>	CS	WE	A ₀	FUNCTION	0	0	0	Writes register address into OPLL.	0	0	1	Writes register contents into OPLL.	0	1	0	Outputs OPLL test data to D ₀ , D ₁ Pins. Normally not used.	0	1	1	OPLL Data Bus high impedance	0	x	x
CS	WE	A ₀	FUNCTION																						
0	0	0	Writes register address into OPLL.																						
0	0	1	Writes register contents into OPLL.																						
0	1	0	Outputs OPLL test data to D ₀ , D ₁ Pins. Normally not used.																						
0	1	1	OPLL Data Bus high impedance																						
0	x	x																							
IC	I	Resets the system when level is low, clearing OPLL Registers.																							
MO RO	O	Melody (MO) and Rhythm (RO) Outputs. Both outputs are source followers. Integrated circuitry and an amplifier are necessary for subsequent processing.																							
Vcc	I	+5V Power Pin.																							
GND	-	Ground Pin.																							

(II-4) Bus Control

The signals \overline{CS} , \overline{WE} and A0 provide control in the data bus for items such as addressing the register in OPLL and read/write of the data. Namely, they select one of four operating modes as follows.

Table II-1 Mode selection

	\overline{CS}	\overline{WE}	A0	
1	1	x	x	Inactive mode
2	0	0	0	Address write mode
3	0	0	1	Data write mode
4	0	1	0	Bus inhibited

(a) Inactive mode

The bus lines ($D_0 \sim D_7$) are at high impedance while \overline{CS} is '1'.

(b) Address write mode

When writing an address, set the control signals to the address write mode and place the address data on the data bus. The address of the specified internal register is now ready to receive data. After writing an address, be sure to wait for 12 cycles of the master clock (ϕM) before writing in sound data.

(c) Data write mode

When the control signals as set for the data write mode, the data existing on the data bus enters the register of the given address. Wait for 84 cycles of the master clock (ϕM) before writing in further data or another address.

(d) Bus inhibited

In this mode, the data of the data bus is meaningless and uncontrollable.

Take note of the following regarding the address/data write modes.

OPLL needs a certain length of wait time between successive writings of addresses or data into the registers. The wait time varies between the address and data write modes. The processor waits for a time shown in Tabel II-2 before OPLL performs another function. If the wait time is not observed data will be uncertain.

Table II-2 Wait times

Mode	Wait time
Address write	12 cycles
Data write	84 cycles

Note: The wait times are given in cycles of the master clock.

(II-5) Channels and Slots

OPLL can produce nine channels of FM sounds as it has two operator cells per channel. However the FM Generator system has only one operator cell, therefore, calculation for nine channels of FM sound is performed by passing through the operator cell 18 times. The order (slot number) of the pass through the operator cell corresponds to the register number. Control of the sound production is effected by controlling the register associated with the slot. Channel data, like the F-number, controls two slots, No.1 and 2. In FM mode, the No.1 slot handles the modulating waves and the No.2 slot the carrier. The No.1 slot can also be set for feedback FM mode. See (III-1-3) for setting this mode.

Table II-3 Channels and Slots

1	2	3	4	5	6	7	8	9	10	11	12	13	14	15	16	17	18	Slot No.
1	2	3	1	2	3	4	5	6	4	5	6	7	8	9	7	8	9	Channel No.
1			2			1			2			1			2			Slot No. when a channel is seen
20	21	22	20	21	22	23	24	25	23	24	25	26	27	28	26	27	28	Relationship between the data of each channel and the register. (Example S20 to S28)

(II-6) Block Diagram

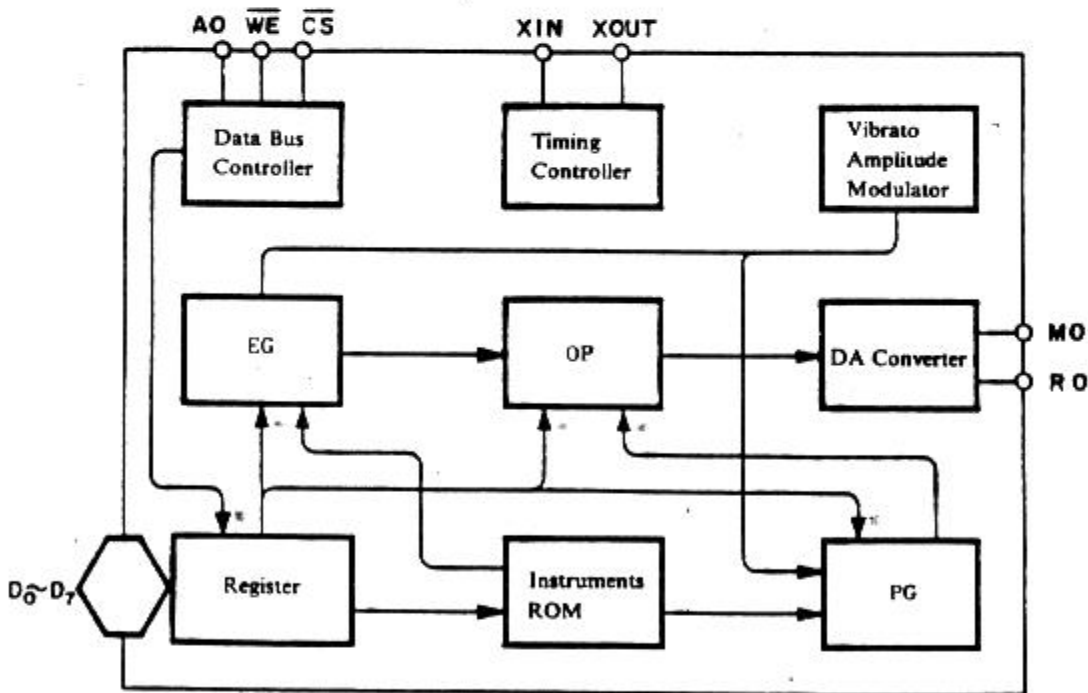

(II-7) Register Map

Address	D ₇	D ₆	D ₅	D ₄	D ₃	D ₂	D ₁	D ₀		
00	A	V	E	K	MULTI					
01	M	B	P	R						
02	KSL			T	L	M				
03				DC	DM	F	B	User Tone Register		
04	A R			D R						
05										
06	S L			R R			© : Carrier Ⓜ : Modulator			
07										
0E	R			BD	SD	TOM	T	CT	HH	Rhythm Control
0F	T E S T								OPLL Test Data (Normal '0')	
10	F-Num. 0 ~ 7								F-Number LSB 8 bits	
20	S U S			K E Y			BLOCK		F	F-Number MSB, Octave set
21							0 ~ 2		N	Key ON/OFF Register
28	ON			ON					u	Sustain ON/OFF Register
29	OFF			OFF					m	
30	INST.			VOL			Instruments Selection and Volume Register			
31										
38										

Register map for Rhythm mode (addr. \$0E D₅ = 'H')

36		BD-VOL	Rhythm volume register
37	HH-VOL	SD-VOL	
38	TOM-VOL	T-CY-VOL	

Register Contents

	Address	Bit	
1	00 : (M) 01 : (C)	D7	Amplitude modulation ON/OFF switch
		D6	Vibrato ON/OFF switch
		D5	Sustained tone/decaying tone switch. 0: Percussive tone 1: sustained tone
		D4	RATE key scale
		D0 ~ D3	Controls MULTI sample wave - harmonics relationship
2	02, 03	D6, D7	LEVEL key scale S02 : (M), S03 : (C)
3	02	D0 ~ D5	Modulator total level. Modulation index control
4	03	D4 : (C) D3 : (M)	Carrier and modulated wave distortion waveform (flat wave rectification) ON/OFF switch
		D0 ~ D2	FM feedback constant : (M)
5	04 : (M) 05 : (C)	D4 ~ D7	Attack envelope change rate control
		D0 ~ D3	Decay envelope change rate control
6	06 : (M) 07 : (C)	D4 ~ D7	Indication of decay - sustain level
		D0 ~ D3	Release envelope change rate control
7	0E	D5	Rhythm sound mode selection. 1: Rhythm sound mode 0: Melody sound mode
		D0 ~ D4	Rhythm instruments ON/OFF switch
8	10 ~ 18	D0 ~ D7	F-Number LSB 8 bits
9	20 ~ 28	D5	Sustain ON/OFF switch
		D4	Key ON/OFF
		D1 ~ D3	Octave setting
		D0	F-Number MSB
10	30 ~ 38	D4 ~ D7	Instruments selection
		D0 ~ D3	Volume data

Tone Data

INST	Instrument	INST	Instrument
0	Original	8	Organ
1	Violin	9	Horn
2	Guitar	10	Synthesizer
3	Piano	11	Harpsichord
4	Flute	12	Vibraphone
5	Clarinet	13	Synthesizer Bass
6	Oboe	14	Acoustic Bass
7	Trumpet	15	Electric Guitar

	Instrument
BD	Bass drum
SD	Snare drum
TOM	Tom-tom
T-CY	Top Cymbal
HH	High hat

III. DESCRIPTION OF OPERATION

All functions of the OPLL are controlled by data written in a register array by the processor. The data specifies the sound envelope shape, the degree of modulation, frequency, and output mode, etc. A complete set of data defines the sound as that of a piano or violin, etc. For the use of complex varieties of data sets see "Synthesis of music sounds".

(III-1) Registers

A register comprises an area of 271 bits, as shown in the address map II-7. The address referred to here is the sub-address assigned to each register of the OPLL. Musical sound data will be written into a register referred to by the sub-address. To store a data in the OPLL, we send a sub-address then the sound data. If we access a location having the same sub-address many times, we only have to send the sub-address the first time. In subsequent accesses, we can send sound data alone to renew old data.

All registers are cleared to 0 by initialization (initial clear: \overline{IC} terminal = 0).

(III-1-1) TEST : ADDRESS [\$0F]

This address is established to test this LSI.

Normally all addresses are 0.

(III-1-2) AM/VIB/EG-TYP/KSR/MULTIPLE : ADDRESS [\$00, \$01]

This register controls the multiplying factor that converts F-number into the carrier (\$01) and modulator (\$00) frequencies which matches the sound frequency components, and the envelope shape etc.

\$00, \$01

D ₇	D ₆	D ₅	D ₄	D ₃	D ₂	D ₁	D ₀
AM	VIB	EG-TYP	KSR	MULTI			
				2 ³	2 ²	2 ¹	2 ⁰

D₀ - D₃ (MULTIPLE) : The frequencies of the carrier wave and the modulated wave are controlled according to the multiplying factors in Table III-1.

< Example > $F(t) = E \sin(\omega t) + I \sin(7 \omega t)$

Frequency according to F-number	ωf
Carrier multiple	1
Modulator multiple	7

Table III - 1 Multiplying factors

MUL	Multiplication factor	MUL	Multiplication factor	MUL	Multiplication factor	MUL	Multiplication factor
0	1/2	4	4	8	8	C	12
1	1	5	5	9	9	D	12
2	2	6	6	A	10	E	15
3	3	7	7	B	10	F	15

D₄ (KSR) : This bit specifies the key scale of RATE.

Since almost all musical steps become high for natural instruments, the sound can quickly change to high or low. This is accomplished by the key scale of RATE. Values in Table III - 2 include the speed offset for the musical steps. Therefore, the actual RATE set for the ADSR will be these values which include the offset.

$$\text{RATE} = 4 \times R + R \text{ ks}$$

- o R is the set value for ADSR
- o R ks is the key scale offset value
- o Note that when R = 0, RATE = 0

Table III - 2

0	1	2	3	4	5	6	7	Octave								
0	1	2	3	4	5	6	7	BLOCK Data								
0	1	0	1	0	1	0	1	0	1	0	1	0	1	F-Num-MSB		
0	0	0	0	1	1	1	1	2	2	2	2	3	3	3	3	D ₄ = 0 key scale
0	1	2	3	4	5	6	7	8	9	10	11	12	13	14	15	D ₄ = 1 off set

D₅ (EG-TYP) : Switching between sustained tone and Percussive tone.

When D₅ = "0," it will be percussive tone. When D₅ = "1," it will be sustained tone. These sound modes are different in that the RELEASE RATE usage differs. The difference is shown in Figure III - 1.

Percussive Tone (D₅ = 0)

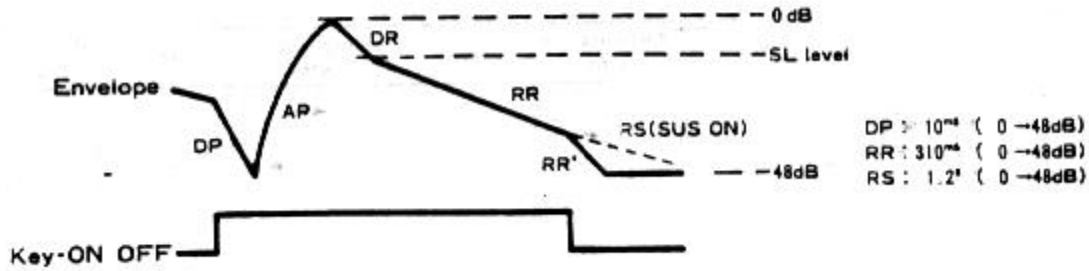

Sustained Tone

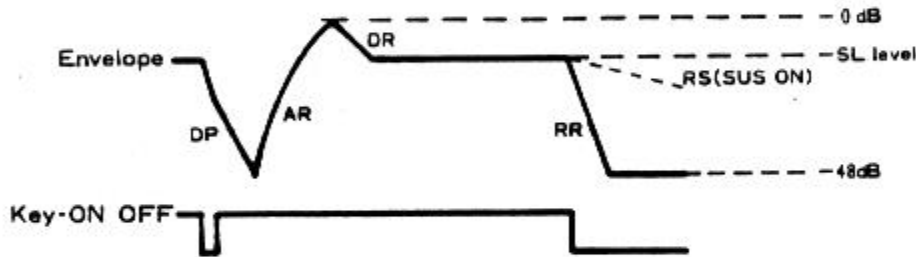

D₆ (VIB) : Vibrato on/off switch. When this bit is "1", vibrato will be applied to the slot. The frequency is 6.4 Hz (@ $\sigma M = 3.6$ MHz).

D₇ (AM) : Amplitude modulation on/off switch. When this bit is "1", amplitude modulation will be applied to the slot. The frequency is 3.7 Hz (@ $\sigma M = 3.6$ MHz).

(III-1-3) KSL/TOTAL LEVEL/DISTORTION/FEED BACK LEVEL : ADDRESS [\$02, \$03]
 Total Level is used to control the modulation index (tone) by adding attenuation to the output of the envelope generator. Level key scale (KSL) ensures, like the key scale of RATE, that the output level of natural musical instruments falls as the pitch of sound rises.

	D7	D6	D5	D4	D3	D2	D1	D0
\$02	KSL		Total Level					
\$03			DC	DM	FB			

D₀ ~ D₅ (Total Level) : The minimum resolution of the attenuation level is 0.75 dB and the sound level can be reduced down to 47.25 dB.

Table III-3 Total level

	D ₄	D ₅	D ₆	D ₇	D ₈	D ₉
Attenuation level	24 dB	12 dB	6 dB	3 dB	1.5 dB	0.75dB

D₆ · D₇ (KSL) : This bit controls the level of key scaling. In key scale mode, the level of attenuation increases as pitch rises, to 1.5 dB/oct, 3dB/oct, 6 dB/oct, and 0 dB/oct.

Table III-4

D ₆	D ₇	Attenuation rate
0	0	0
1	0	1.5dB/OCT
0	1	3 dB/OCT
1	1	6 dB/OCT

Table III-5 Attenuation at each F-Number at 3 dB/OCT.

F-Num OCT	0	1	2	3	4	5	6	7
	8	9	10	11	12	13	14	15
0	0.000	0.000	0.000	0.000	0.000	0.000	0.000	0.000
1	0.000	0.750	1.125	1.500	1.875	2.250	2.625	3.000
2	0.000	0.000	0.000	0.000	0.000	1.125	1.875	2.625
3	0.000	0.000	0.000	1.875	2.000	4.125	4.875	5.625
4	0.000	0.000	0.000	4.875	6.000	7.125	7.875	8.625
5	0.000	0.000	0.000	7.875	9.000	10.125	10.875	11.625
6	0.000	0.000	0.000	10.875	12.000	13.125	13.875	14.625
7	0.000	0.000	0.000	13.875	15.000	16.125	16.875	17.625

UNIT : dB

Notes:

- F-Number is the value of the four MSBs..
- Half of the above data at 1.5 dB/oct
- Double of the above data at 6 dB/oct

S03

D₃ DM : The modulated wave is rectified to half wave.

D₄ DC : The carrier wave is rectified to half wave.

S03

D₀ to D₂ (FEEDBACK) : For the modulated wave of the first slot's feedback FM modulation.

Table III - 6 Modulation index

	0	1	2	3	4	5	6	7
Modulation index	0	$\pi/16$	$\pi/8$	$\pi/4$	$\pi/2$	π	2π	4π

(III-1-4) ATTACK/DECAY RATE : ADDRESS [S04~S05]

Attack Rate defines the attack time of the sounds, and Decay Rate the decay time. The Rates are set as given in Table III - 7.

	D7	D6	D5	D4	D3	D2	D1	D0	
	AR				DR				
S04	2 ¹	2 ¹	2 ¹	2 ⁰	2 ¹	2 ²	2 ¹	2 ⁰	Modulator
S05	2 ¹	2 ¹	2 ¹	2 ⁰	2 ¹	2 ²	2 ¹	2 ⁰	Carrier

(III-1-5) SUSTAIN LEVEL/RELEASE RATE : ADDRESS [S06~S07]

Sustain Level is the critical point that, when sustaining sound has been attenuated to the prescribed level, the level is maintained thereafter. With percussive tone, it is the critical point of change from decay mode to release mode.

Release Rate is the disappearing rate of sustaining sounds after key OFF. For percussive tone, attenuation above the sustain level is expressed with decay rate and attenuation below the sustain level with release rate.

	D7	D6	D5	D4	D3	D2	D1	D0	
	SL				RR				
S06	24dB	12dB	6dB	3dB	2 ¹	2 ²	2 ¹	2 ⁰	Modulator
S07	24dB	12dB	6dB	3dB	2 ¹	2 ²	2 ¹	2 ⁰	Carrier

* Attenuation times of the release rate are the same as that of the decay rate.

TABLE III-7 ATTACK AND DECAY TIMES IN RELATION TO RATE

RATE given below is that of the after key scale. RATE = RM x 4 + RL

*****			*****			*****		
EG DECAY TIME			EG ATTACK TIME			*****		
[mS]			[mS]			[mS]		
RM-RL	0dB - 40dB	10% - 90%	RM-RL	0dB - 40dB	10% - 90%	RM-RL	0dB - 40dB	10% - 90%
15 3	1.27	0.52	15 0	0.00	0.00	15 0	0.00	0.00
15 2	1.27	0.52	15 0	0.00	0.00	15 0	0.00	0.00
15 1	1.27	0.52	15 0	0.00	0.00	15 0	0.00	0.00
15 0	1.27	0.52	15 0	0.00	0.00	15 0	0.00	0.00
14 3	1.47	0.60	14 3	0.14	0.10	14 3	0.14	0.10
14 2	1.71	0.68	14 2	0.18	0.12	14 2	0.18	0.12
14 1	2.05	0.82	14 1	0.22	0.14	14 1	0.22	0.14
14 0	2.55	1.03	14 0	0.28	0.18	14 0	0.28	0.18
13 3	2.94	1.21	13 3	0.30	0.22	13 3	0.30	0.22
13 2	3.42	1.37	13 2	0.34	0.22	13 2	0.34	0.22
13 1	4.10	1.65	13 1	0.42	0.26	13 1	0.42	0.26
13 0	5.11	2.05	13 0	0.50	0.32	13 0	0.50	0.32
12 3	5.87	2.41	12 3	0.54	0.36	12 3	0.54	0.36
12 2	6.84	2.74	12 2	0.60	0.38	12 2	0.60	0.38
12 1	8.21	3.30	12 1	0.70	0.44	12 1	0.70	0.44
12 0	10.22	4.10	12 0	0.84	0.54	12 0	0.84	0.54
11 3	11.75	4.83	11 3	0.97	0.64	11 3	0.97	0.64
11 2	13.68	5.47	11 2	1.13	0.72	11 2	1.13	0.72
11 1	16.41	6.60	11 1	1.37	0.84	11 1	1.37	0.84
11 0	20.44	8.21	11 0	1.69	1.09	11 0	1.69	1.09
10 3	23.49	9.65	10 3	1.93	1.29	10 3	1.93	1.29
10 2	27.36	10.94	10 2	2.25	1.45	10 2	2.25	1.45
10 1	32.83	13.19	10 1	2.74	1.69	10 1	2.74	1.69
10 0	40.87	16.41	10 0	3.30	2.17	10 0	3.30	2.17
9 3	46.99	19.31	9 3	3.86	2.57	9 3	3.86	2.57
9 2	54.71	21.80	9 2	4.51	2.90	9 2	4.51	2.90
9 1	65.65	26.39	9 1	5.47	3.30	9 1	5.47	3.30
9 0	81.74	32.83	9 0	6.76	4.34	9 0	6.76	4.34
8 3	93.97	38.62	8 3	7.72	5.15	8 3	7.72	5.15
8 2	109.42	43.77	8 2	9.01	5.79	8 2	9.01	5.79
8 1	131.31	52.78	8 1	10.94	6.76	8 1	10.94	6.76
8 0	163.49	65.65	8 0	13.52	8.69	8 0	13.52	8.69
7 3	187.95	77.24	7 3	15.45	10.30	7 3	15.45	10.30
7 2	218.84	87.54	7 2	18.02	11.59	7 2	18.02	11.59
7 1	262.61	105.56	7 1	21.80	13.52	7 1	21.80	13.52
7 0	326.98	131.31	7 0	27.03	17.38	7 0	27.03	17.38
6 3	375.98	154.48	6 3	30.90	20.60	6 3	30.90	20.60
6 2	437.69	175.07	6 2	36.84	23.17	6 2	36.84	23.17
6 1	525.22	211.12	6 1	43.77	27.03	6 1	43.77	27.03
6 0	653.95	262.61	6 0	54.07	34.76	6 0	54.07	34.76
5 3	751.79	308.96	5 3	61.79	41.19	5 3	61.79	41.19
5 2	875.37	350.15	5 2	72.09	46.34	5 2	72.09	46.34
5 1	1050.45	422.24	5 1	87.54	54.07	5 1	87.54	54.07
5 0	1307.91	525.22	5 0	108.13	69.51	5 0	108.13	69.51
4 3	1503.58	617.91	4 3	123.58	82.39	4 3	123.58	82.39
4 2	1750.75	700.30	4 2	144.18	92.69	4 2	144.18	92.69
4 1	2100.89	844.48	4 1	175.07	108.13	4 1	175.07	108.13
4 0	2615.82	1050.45	4 0	216.27	139.03	4 0	216.27	139.03
3 3	3087.16	1235.82	3 3	247.16	164.78	3 3	247.16	164.78
3 2	3501.49	1400.60	3 2	288.36	185.37	3 2	288.36	185.37
3 1	4201.79	1680.95	3 1	350.15	216.27	3 1	350.15	216.27
3 0	5231.64	2100.89	3 0	432.54	278.06	3 0	432.54	278.06
2 3	6014.72	2471.64	2 3	494.33	329.55	2 3	494.33	329.55
2 2	7002.98	2801.19	2 2	576.72	378.75	2 2	576.72	378.75
2 1	8403.58	3377.91	2 1	700.30	432.54	2 1	700.30	432.54
2 0	10463.30	4201.79	2 0	865.08	556.12	2 0	865.08	556.12
1 3	12078.66	4943.28	1 3	988.66	659.11	1 3	988.66	659.11
1 2	14004.00	5602.39	1 2	1153.43	741.49	1 2	1153.43	741.49
1 1	16807.20	6755.82	1 1	1400.60	865.08	1 1	1400.60	865.08
1 0	20974.60	8403.58	1 0	1738.15	1112.24	1 0	1738.15	1112.24

Note: When RATE is "0", the envelope will not change.

(III-1-6) BLOCK/F-NUMBER : ADDRESS [SA0~SB8]

Data defining a musical scale and interval. The F-Number is contained in the registers S1* and S2*.

S10~S18	D7	D6	D5	D4	D3	D2	D1	D0
	F-Number							
	2 ⁷	2 ⁶	2 ⁵	2 ⁴	2 ³	2 ²	2 ¹	2 ⁰

S20~S28	D7	D6	D5	D4	D3	D2	D1	D0
	/		SUS-ON	KEY-ON	BLOCK			F-NUMBER
OFF			OFF	2 ³	2 ²	2 ¹	2 ⁰	

D0~D7 [S1*], D0 [S2*] (F-Number):

The F-Number is defined with 8 bits of the S1* register and LSB of S2*, for a total of 9 bits. This F-Number defines a scale (how a value is assigned to the F-number is described later.)

D1~D3 (BLOCK) : Defines octave information.

D4 (Key-ON) : This bit indicates the ON/OFF state of the key. When this bit is "1", the associated channel is on and sound is produced. "0" is equivalent to Key-OFF.

D5 (SUS-ON/OFF) : When this bit is "1", the RR with the key off will be 5.

*** F-Number/Block**

The OPLL generates the necessary frequency when an appropriate increment of phase is given. The increment is determined by F-Number, Block, and Multiple information. The following formula gives the increment for a desired frequency.

$$\Delta P = f_{mus} * 2^{18} / f_{sam} \dots\dots\dots \textcircled{1}$$

$$f_{sam} = f_M / 72$$

- f_{mus} : Desired frequency
- f_{sam} : Sampling frequency (50 kHz)
- f_M : Input clock frequency (3.6 MHz)

Because the increment value specification occupies many bits, we can give the increment within an octave and shift the value to double, 4 times, etc. for a specific octave. Then the increment is expressed as follows.

$$\Delta P = 2^B * F' * MUL \dots\dots\dots \textcircled{2}$$

- B : Octave information
- F' : Increment within an octave
- MUL : Multiple data

From equation $\textcircled{1}$ and $\textcircled{2}$ the increment (F') is expressed with 1 bit, F-Number and Block are expressed as follows.

$$F = (f_{mus} * 2^{18} / f_{sam}) / 2^{b-1} \quad @ \text{ Mul} = 1$$

- F : F-Number data
- b : Block data

*F * 2^{b-1} = f_{mus} * 2^{18}*
f_{sam}
*f_{sam} = F * 2^{b-1} * f_{sam}*
*F * 2^{b-1} = f_{mus} * 2^{18} / f_{sam}*

Table III-8-1 F-Number (1)

Sound steps	Frequency (4 oct)	F-Number	S2*		S1*						
			D0	D7	D6	D5	D4	D3	D2	D1	D0
C#	277.2	181	0	1	0	1	1	0	1	0	1
D	293.7	192	0	1	1	0	0	0	0	0	0
D#	311.1	204	0	1	1	0	0	1	1	0	0
E	329.6	216	0	1	1	0	1	1	0	0	0
F	349.2	229	0	1	1	1	0	0	1	0	1
F#	370.0	242	0	1	1	1	1	0	0	1	0
G	392.0	257	1	0	0	0	0	0	0	0	1
G#	415.3	272	1	0	0	0	1	0	0	0	0
A	440.0	288	1	0	0	1	1	0	0	0	1
A#	466.2	305	1	0	0	1	1	0	0	1	1
B	493.9	323	1	0	1	0	0	0	0	1	1
C#	523.3	343	1	0	1	0	1	0	1	1	1

Table III-8-2 F-Number (2)

Sound steps	Frequency (4~5 oct)	F-Number	\$2*	\$1*								
			D ₀	D ₇	D ₆	D ₅	D ₄	D ₃	D ₂	D ₁	D ₀	
G	392.2	257	1	0	0	0	0	0	0	0	0	1
G [#]	415.3	272	1	0	0	0	1	0	0	0	0	0
A	440.0	288	1	0	0	1	0	0	0	0	0	0
A [#]	466.2	305	1	0	0	1	1	0	0	0	0	1
B	493.9	323	1	0	1	0	0	0	0	0	1	1
C	523.3	343	1	0	1	0	1	0	1	1	1	1
C [#]	554.4	363	1	0	1	1	0	1	0	1	1	1
D	587.3	385	1	1	0	0	0	0	0	0	0	1
D [#]	622.2	408	1	1	0	0	1	1	0	0	0	0
E	659.3	432	1	1	0	1	1	0	0	0	0	0
F	698.5	458	1	1	1	0	0	1	0	1	0	0
F [#]	740.0	485	1	1	1	1	0	0	1	0	1	1

(III-1-7) RHYTHM : ADDRESS [\$0E]

To control ON/OFF of the Rhythm mode selection and percussion instruments.

	D ₅	D ₄	D ₃	D ₂	D ₁	D ₀
RHYTHM		BD	SD	TOM	TOP-CY	HH

D₀~D₅ (RHYTHM) : When D₅ = 1, OPLL is in Rhythm mode with percussion sounds produced through channels 7~9 (see page 5). In this mode, the melody section is limited to six sounds. D₀~D₄ controls ON/OFF of percussion instruments. Therefore the Key-ON bits \$26, \$27, \$28 must always be cleared to 0. Slots 13~18 are related with percussion sounds as shown in Table III-9, and data of F Num must input values that match percussion sounds.

Table III-9 Rhythm slots

Instrument	Slot	Address	Data
BD	13,16	16	20
SD	17	17	50
TOM	15	18	C0
TOP-CYM	18	26	05
HH	14	27	05
		28	01

(III-1-8) INSTRUMENT/VOLUME: ADDRESS [\$30~\$38]

Determine the voice (15 voices preset in ROM and original voices) and the volume.

\$30~\$38	D7	D6	D5	D4	D3	D2	D1	D0
	INST				VOL			

D₄~D₇ (INST.) : These four bits determine voices as follows:

INST	Instrument	INST	Instrument
0	Original	8	Organ
1	Violin	9	Horn
2	Guitar	A	Synthesizer
3	Piano	B	Harpsichord
4	Flute	C	Vibraphone
5	Clarinet	D	Synthesizer Bass
6	Oboe	E	Wood Bass
7	Trumpet	F	Electric Guitar

D₀~D₃ (VOL) : Determines the volume for the voices. The minimum resolution is 3 dB and the maximum 45 dB.

D3	D2	D1	D0
24dB	12dB	6dB	3dB

In the rhythm mode (addr = \$0E, D₅ = "H"), each rhythm volume for \$36~\$38 are set as follows:

addr	D7	D6	D5	D4	D3	D2	D1	D0
\$36					BD			
\$37	HH				SD			
\$38	TOM				T-CYM			

(III - 2) Phase Generator (PG)

The phase generator produces a phase value by accumulating increments that correspond to the frequency required at a given unit of time. The increment is generated from frequency data (F-Number, Block, and Multiple) sent from the registers. The frequency data is combined with the output of a built-in vibrato oscillator to produce a vibrato effect.

(III - 3) Envelope Generator (EG)

The envelope generator (EG) varies tone and sound level with time under the control of ATTACK RATE, DECAY RATE, RELEASE RATE, Sustain Level and Total Level. Its dynamic range is 48 dB (resolution: 0.325 dB). EG uses a logarithmic scale and is represented with an attenuation level. The general waveform is shown in Figure III-2. Distinctively the waveform rises exponentially during attack time and varies linearly everywhere else. Attack stops and decay begins at 0 dB. Decay changes to sustain as soon as the sustain level is reached. Sustain will change to release when the key is released. The envelope waveform varies when parameters representing the effects of the total level, level key scale, and amplitude modulation, etc. are applied to EG.

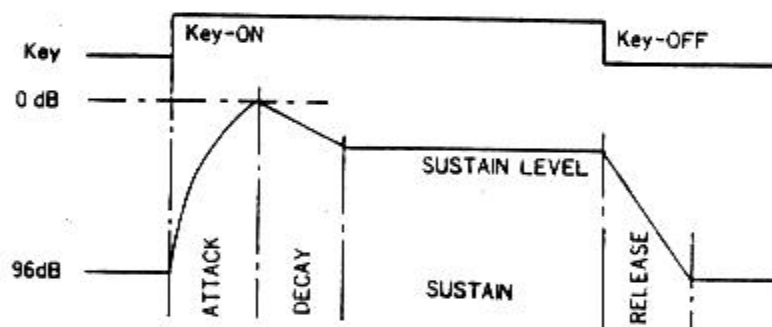

Figure III - 2 Envelope waveform

(III - 4) Operator (OP) and DAC

The operator performs FM calculations. Using the phase output from the phase generator, the operator calculates the value of SIN and multiplies it by the output of the envelope generator. Then if there are modulated waves, they are returned to the input of the operator and any sounds are sent to the DAC. This is controlled by the Feedback data.

The DAC performs DA conversion for all the sounds then outputs them as shown in Figure III - 3 (a). To sum up the sounds, an integrated circuit is added to Mo. Ro. [Figure III - 3 (b)] Since the level of percussion sounds seem lower, when compared to music sounds, the same percussion sounds are output twice. [Figure III - 3 (c)]

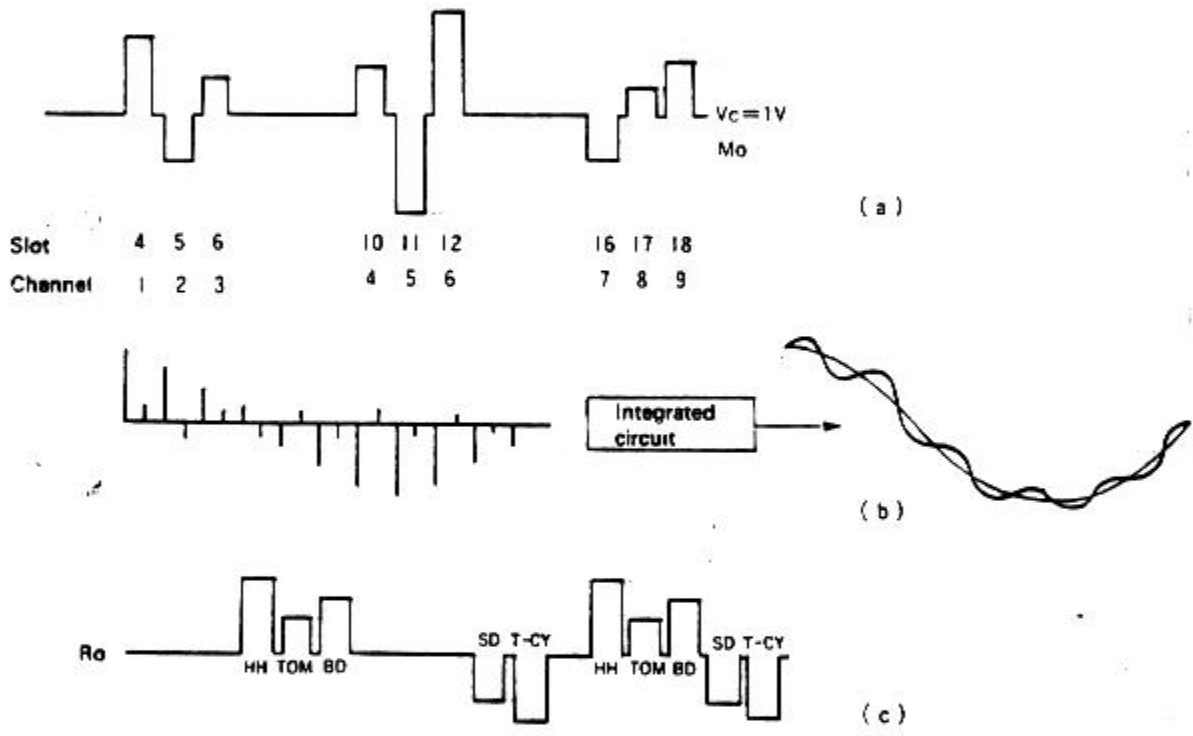

Figure III - 3

IV. INTERFACING

OPLL, controlled by a microprocessor or microcomputer, outputs an audio signal, being an analog signal converted with a D/A converter. To obtain sound from OPLL, it is necessary to interface it with other devices. This chapter describes interfacing.

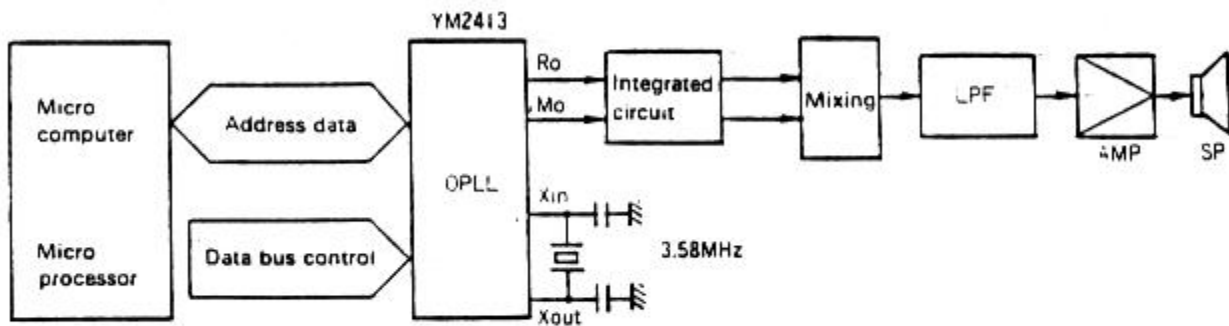

Figure IV - 1 System block diagram

(IV - 1) Clock Generation

OPLL operates in the range of 2 to 4 MHz. Amplitude modulation, the frequency of the vibrato oscillator, and attack decay speeds are designed to take 3.6 MHz (3.579545 MHz) as the reference frequency. Therefore, when this LSI is used, it will be economical to connect the quartz crystal oscillator (for color burst signals) with Xin Xout.

(IV - 2) Audio Output Interface

An external integrated circuit is needed for the OPLL's music sound output, which is a pulse signal as described earlier. The output (and buffer) of this integrated circuit may be directly connected to an audio amplifier. For better sound quality, you can remove step noises by inserting a low-pass filter (cutoff frequency: 20 kHz or so) between the integrated circuit and amplifier. Click noises accompanying power-ON/OFF will be necessary to protect the audio equipment (amplifier and speakers).

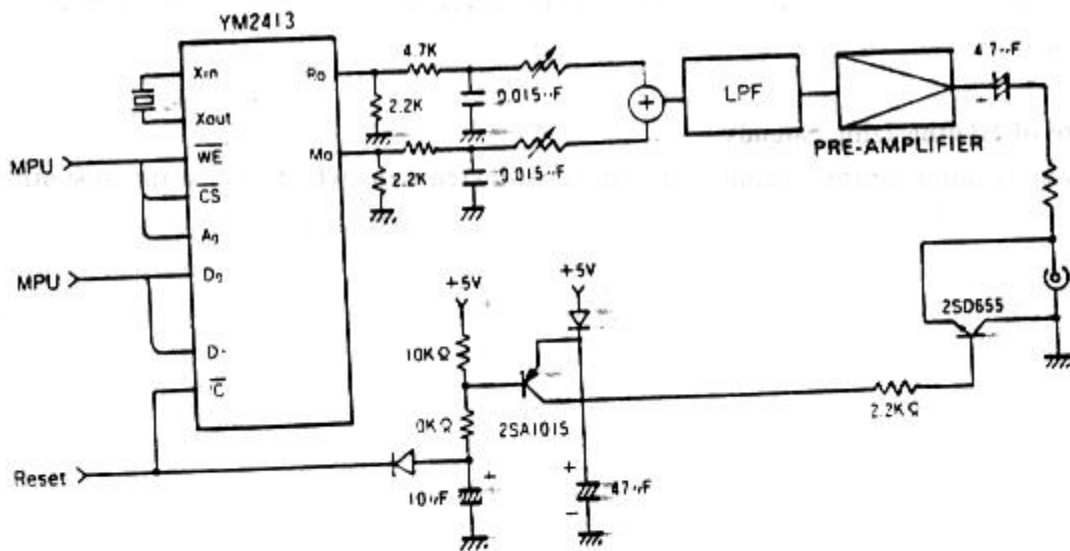

Figure IV - 2 Audio interface

(IV - 3) INTERFACING MICROPROCESSOR/MICROCOMPUTER

$D_0 \sim D_7$ of OPLL are the bidirectional bus lines which connect to a processor. OPLL exchanges address and data with the processor. The bus control signals \overline{CS} , \overline{WE} and A_0 control transfer of data. It is possible to build up an FM sound source system with the minimum configuration of OPLL, memory, and processor.

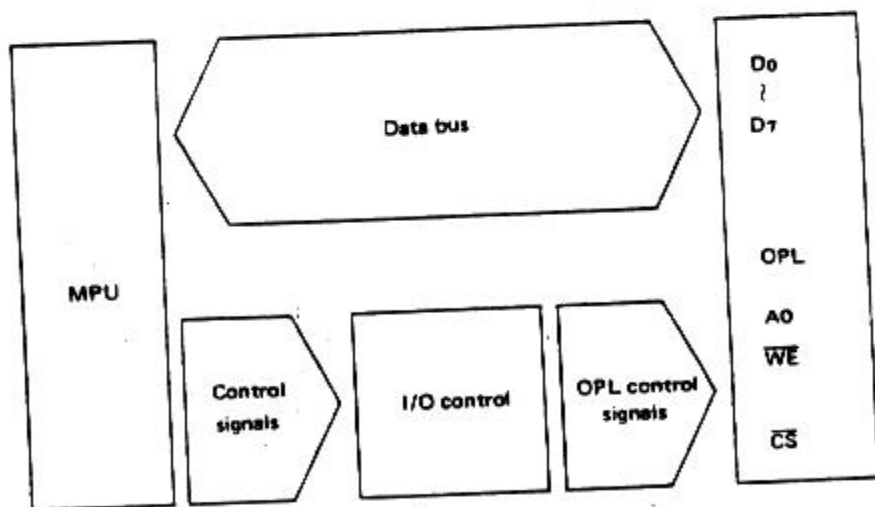

Figure IV - 3 Interfacing processor

V. SYNTHESIS OF MUSIC SOUNDS

This chapter describes what data to enter the OPLL registers in order to synthesize sound of the piano and brass.

(V-1) Procedure of Synthesizing Sounds

First, you have to analyze the sounds of the musical instrument which you want to synthesize by the FM method. For example, the sound of a piano is characterized by a fast attack and, if the key is held down, a gradual decay. The will sound include many overtones at the attack time however, as time elapses, overtones disappear, resulting in a different overtone composition. When you are aware such characteristics, you are better able to synthesize the sounds by the FM method. The output amplitude can be determined from the characteristics of the envelope form and the modulation index from the overtone composition. Frequency ratio can also be determined roughly from the overtone composition because the frequency of the operator is related to it. In this way, you can determine the FM parameters roughly from characteristics of the sounds and, by listening to the synthesized sound, make minor corrections to obtain a more desirable result.

(V-2) Fundamentals of Sound Synthesis

The FM sound source makes use of carrier wave modulation by the modulator.

Since the FM's basic parameter (carrier output level, modulator output level, modulator feedback level, carrier frequency, modulator frequency) is handled effectively, the pitch, tone and volume of sounds can all be decided. Table V-1 shows the relationship between FM parameters and OPLL parameters.

(V-3) Examples of Sound Synthesis

Table V-1 Fundamentals of sound synthesis

Item	Related parameters	MIN ← (Change of sounds) → MAX
Output level of carrier	TOTAL LEVEL (Data of A, D, S, R, and Key Scale data)	Low volume ↔ High volume
Output level of modulator		Dull sound ↔ Bright sound
Feedback level of modulator	F B	Ordinary tone ↔ Sharp tone (Noise)
Carrier frequency	MULTI (BLOCK/F-Number)	Low pitch ↔ High pitch
Frequency of modulator		Near overtone ↔ Far overtone

(i) Electric piano

① Determination of operator frequencies

Set MULTIPLE to "1", for both operators, to produce an overtone of higher frequency. (Increases are by integer multiples)

② Output level of the operator

Change the output of the modulator to adjust the tone. When determining the level of operator 1, adjust the bass sounds for rich overtones like those of the piano. Then make adjustment for sounds of higher frequencies by level scaling of operator 1. Level scaling is necessary so that the waveforms are nearly sine waves in high frequency ranges.

③ Setting EG

Determine sound volume, tone, and envelope. Set operator 2 so that the sounds have a sharp attack and long sustain. (This can be set varying degrees.) Let operator 1, the modulator, produce many overtones at the attack time and later keep a certain composition of overtones unchanged. To adjust sound volume, apply key scaling to operator 2. Perform RATE scaling to make the sounds of higher pitches sharp.

④ Readjustment of data

Now sound synthesis is almost completed. Tones will vary somewhat depending on the setting of EG. Make a final adjustment with the output level and feedback level of the operators. If the sound is too metallic, for example, reduce the level of operator 1.

⑤ Adding effect

Finally, add tremolo effect by LFO to simulate the sounds of the electric piano. This is possible by using the built-in amplitude modulation function or by refreshing the value of TOTAL LEVEL in intervals of 2~6 Hz (possible with triangular waves) by software.

(ii) Trumpet

① Output of operator

Adjust the total level of operator 1, the modulator, at \$10~\$28 and the feedback level to the maximum of "7" for bright tones.

② Operator frequencies

Set both operators at "1".

③ EG

Adjust two EGs for a slow attack. For brass sounds, ensure the modulator attack is slower than the carrier's. This is necessary to express the characteristic attack of brass sounds.

④ Key scaling

High-pitched sounds are not crisp because the envelope is set for a slow rise. Apply rate scaling for a more natural feeling of fast passages.

⑤ LFO

With a brass instrument, the pitch of long tones fluctuates a little even when a good player is playing. To express this, apply vibrato effect.

(V-4) Procedure of Percussion Sound Synthesis

Channels 7, 8 and 9 are used to synthesize percussion sounds. Five kinds of percussion sounds are generated by using these three channels and six slots. For a the bass drum (BD), two slots are used to synthesize FM sounds. Therefore, bass drum sounds can be produced basically by the same procedure from (a) to (c). The other four kinds of percussion sounds (high hat, top cymbal, tom-tom, and snare drum) are described as follows.

OPLL includes a noise oscillator obtained by composing a white noise generator with several frequencies. This noise oscillator is specified by the frequency information (BLOCK, F-Number, Multi) of the 8 and 9 channels. When composed with white noise, phase output suitable for percussion instruments is generated and given to the operator. Thus phases of four instruments are generated from two sets of frequency information. It is known empirically that the optimum ratio of two frequencies is 3 : 1 ($f7CH = 3 \cdot f8CH$). Now phase data of individual instruments are obtained. Next, we multiply this output with envelope information. Since the envelope is set as 1 slot \rightarrow 1 percussion instrument, values that reflect the characteristics of individual percussion instruments, as with melody instruments, are set in tone ROM. (Refer to III-1-7)

VI. ELECTRICAL CHARACTERISTICS

1. Absolute Maximum Ratings

ITEM	RATING	UNIT
Pin voltage	0.3 ~ 7.0	V
Ambient operating temperature	0 ~ 70	°C
Storage temperature	-50 ~ 125	°C

2. Recommended Operating Conditions

ITEM	SYMBOL	MIN.	TYP.	MAX.	UNIT
Supply voltage	V _{CC}	4.75	5	5.25	V
	GND	0	0	0	V

3. DC Characteristics

ITEM	SYMBOL	CONDITION	MIN.	TYP.	MAX.	UNIT
High level input voltage	All input	V _{IH}	2.0		V _{CC}	V
Low level input voltage	All input	V _{IL}	-0.3		0.8	V
Leak input current	A0, WE	I _L	V _{in} = 0 ~ 5 V	-10	10	μA
Three-state (off) input current	D ₀ ~ D ₇	I _{TSL}	V _{in} = 0 ~ 5 V	-10	10	μA
Analog output voltage	MO	V _{MOA}	R _{LOAD} = 2.2K		1.6	V _{pp}
	RO	V _{ROA}	R _{LOAD} = 2.2K		1.6	V _{pp}
Pullup resistance	IC, CS	R _{PU}		100		KΩ
Input capacity	All input	C _i			10	PF
Output capacity	All input	C _o			10	PF
Power current		I _{CC}		40	80	mA

4. AC Characteristics

ITEM	SYMBOL	CONDITION	MIN.	TYP.	MAX.	UNIT
Address setup time	A ₀	T _{AS}	Fig. A-1	10		ns
Address hold time	A ₀	T _{AH}	Fig. A-1	10		ns
Chip select write width	CS	T _{CSW}	Fig. A-1	80		ns
Write pulse write width	WE	T _{WW}	Fig. A-1	110		ns
Write pulse setup time	WE	T _{WS}	Fig. A-1	30		ns
Write data setup time	D ₀ ~ D ₇	T _{WDS}	Fig. A-1	10		ns
Write data hold time	D ₀ ~ D ₇	T _{WDH}	Fig. A-1	25		ns
Reset pulse width	IC	N _{ICW}	Fig. A-2		80	cycle

5. DAC properties

ITEM	SYMBOL	CONDITION	MIN.	TYP.	MAX.	UNIT
Maximum output oscillation	Ro. Mo	Vout	Fig. IV - 2	2/5 Vcc		Vpp
Resolution	Ro. Mo		Fig. IV - 2	9		Bit
Noise	Ro. Mo		Fig. IV - 2	-65		dB

Note: The noise level should be suitable for the volume level.

VII. TIMING DIAGRAMS (STANDARD TIMING SETTINGS ARE $V_{IH} = 2.0V$, $V_{IL} = 0.8V$)

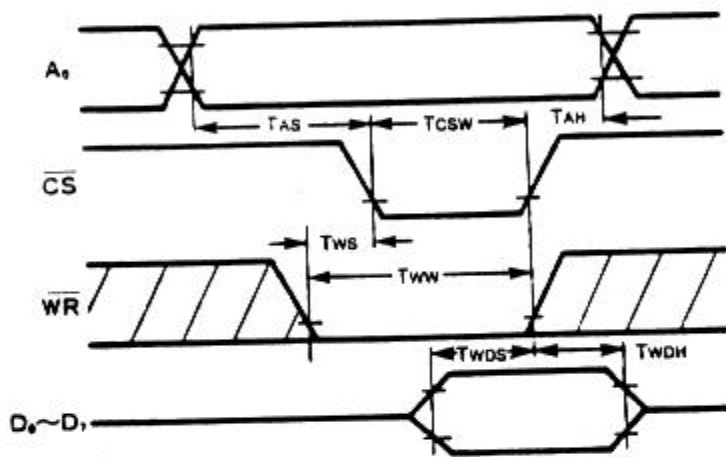

NOTE:
 T_{CSW} , T_{WW} and T_{WDH} have been measured with either \overline{CS} or \overline{WE} high.

Fig. A-1 Write Timing

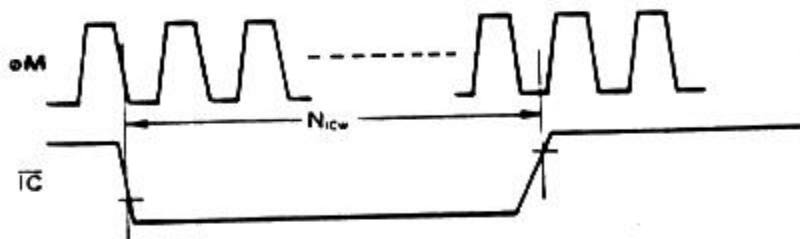
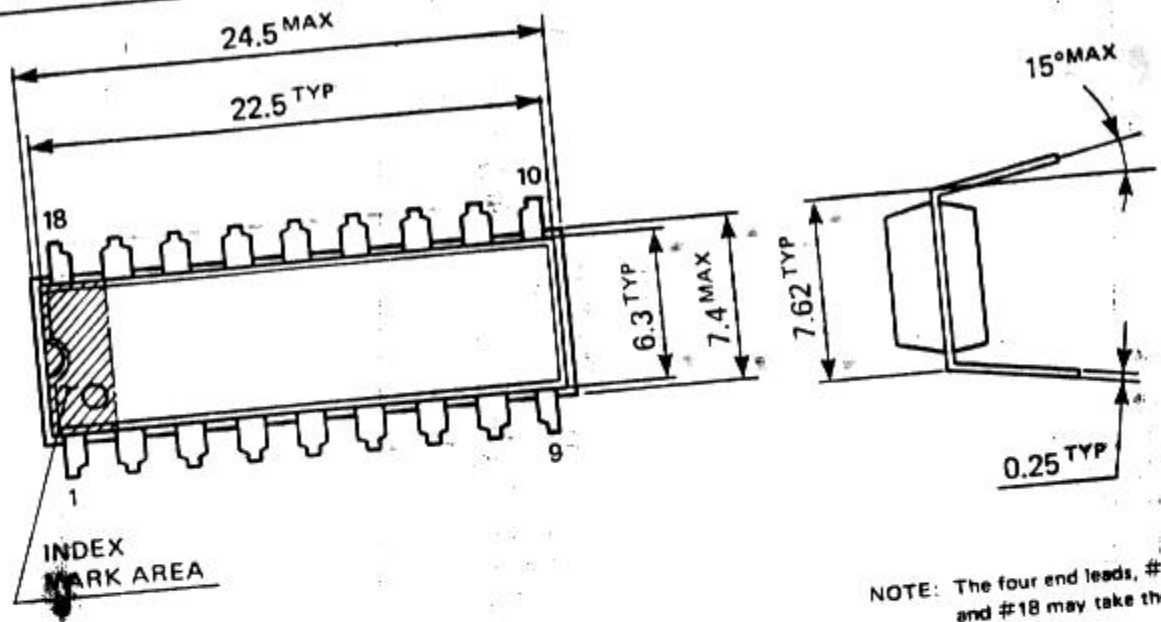
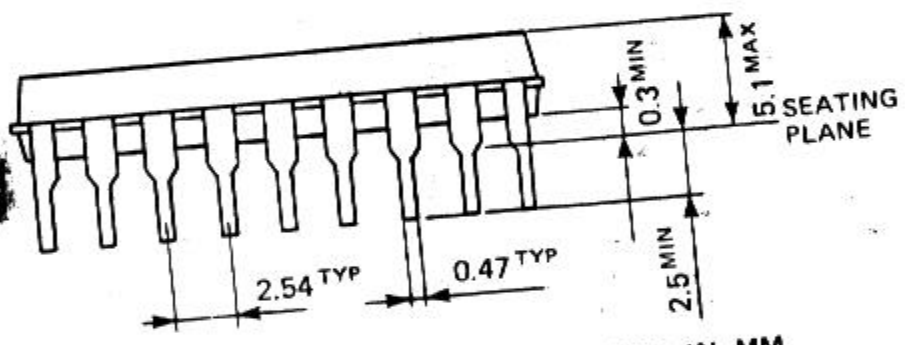

Fig. A-2 Reset Timing

VIII. OUTLINE DIMENSIONS



NOTE: The four end leads, #1, #9, #10, and #18 may take the shape described below.



DIMENSIONS IN MM

18 pin plastic DIP
PK 18DP1-20-1

HI-TOP MSX CLUB
Rua Emilio Andrielli, 163
13810-000 - LEME - SP



The specifications of this product are subject to improvement changes without prior notice.

AGENCY



Alfonso I. 28 • 50003 ZARAGOZA
Tel./Fax (976) 299060
Apdo. Correos 7037 • 50080 ZARAGOZA
ZARAGOZA (Spain)

— YAMAHA CORPORATION —

Address inquiries to:

Electronic System Division

- Toyooka Factory 203, Matsunokijima, Toyooka-mura,
Iwata-gun, Shizuoka-ken, 438-01
Electronic Equipment business section
Tel. 053962-3125
- Tokyo Office 3-4, Surugadai Kanda, Chiyoda-ku,
Tokyo, 104
Ryumeikan Bldg. 4F
Tel. 03-255-4481
- Osaka Office 1-16, Shin-ashiya-shimo, Suita-shi,
Osaka, 565
Tel. 06-877-7731
- U.S.A. YAMAHA International Corp.
6600 Orangethorp Ave.
Buena Park California 90620