

RAZE

INSIDE:
BLOCK OUT
DISC
GREMLINS II
PHANTASY SOLDIER III
QUADREL
SWITCHBLADE II
VERYTEX
VIZ...

**PLUS OVER
100 GAME
BUSTING
TRICKS
AND
TACTICS
FOR ALL MAJOR
CONSOLES AND
COMPUTERS!**

WIN!

**A LYNX, 10 COPIES
OF THE COMPLETE
SEGA SOLUTION
AND A
CD-EQUIPPED
JVC GHETTO
BLASTER!**

SHADOW DANCER

**Expose yourself to the
explosive beat-'em-up action
in this phenomenal coin-op
conversion!**

ATARI 7800

ATARI LYNX

NEC PC ENGINE

NINTENDO

NINTENDO GAME BOY

SEGA MASTER SYSTEM

SEGA MEGA DRIVE

ATARI ST

COMMODORE AMIGA

IBM PC

STICK MIX!

**Over 30 joysticks, joypods and controllers
tried and tested!**



PC SIMS...A SUP

WORLD CLASS

THE MOST ADVANCED SOFTWARE ENTERTAINMENT EXPERIENCE

Take charge of an entire planet from its birth until its death-10 billions years later. Guide life from its inception as single-celled microbes to a civilization that can reach for the stars. THE LIVING PLANET Inspired by James Lovelock's Gaia

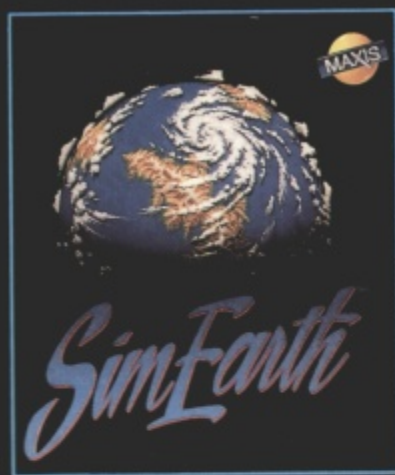

hypothesis, SimEarth simulates the Earth as a single living organism.

THE THINK TANK

Set in the near future, as an alternative reality, Battle Command is an arcade/strategy game in which the player controls a single "Mauler" Assault Tank in one of 16 scenarios (missions) in the ultra war, fought between two dominant races in the new World. Such are the defensive capabilities of each side, full scale attacks are suicidal, so any offensive moves are, by necessity, small "behind the lines" actions performed by elite troops in specially designed vehicles. The Mauler is the latest such machine -



capable of being lifted in and out of hostile territory by fast stealth choppers and armed with the most advanced weaponry the Northern scientists can devise.

ALL AVAILABLE FOR YOUR IBM PC & COMPATIBLES ATARI ST & CBM AMIGA

*SIM EARTH AVAILABLE FOR IBM PC & COMPATIBLES ONLY.

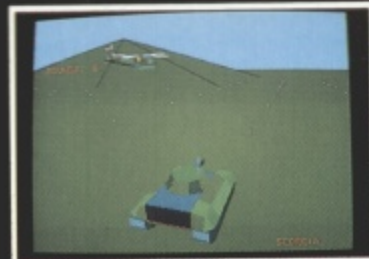

ERIOR SPECIES

THE RIGHT STUFF

F 29 Retaliator presents the fastest and most detailed graphical environment ever seen in a flight simulator. This is the only flight simulation to provide 100 complex missions over four intense battle scenarios. The only flight simulation to provide detailed daily war update reports. The only flight simulation to present the latest in aerodynamic technology introducing ECOP cockpits,

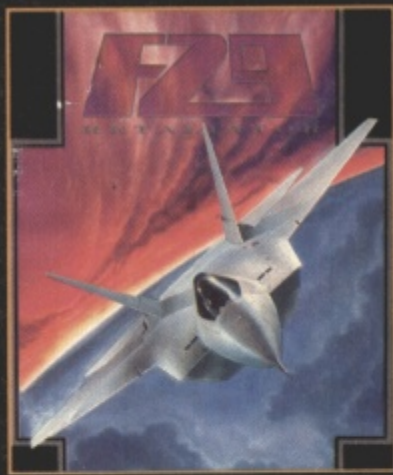

backwinder A A M S , supercruise, stealth and more! F29 Retaliator is that flight simulation.

GUN LAW

"BILLY THE KID" is a one or two player action/strategy game set in the Wild West, which allows the player to assume the identity of either a gun totting desperado with a heart of gold , Billy himself or his ex-best friend, sharp shooting, law abiding pillar of the community, Sheriff Pat Garrett. They are in love with the same woman and ultimately, in a nail biting climatic finale, are going to end up pointing guns at each other. Only one

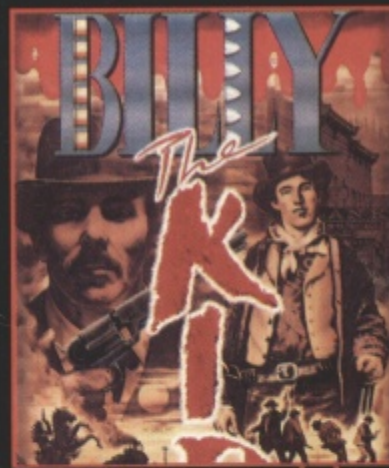

character can walk away from this showdown BUT THAT'S JUST THE WAY OF THE WEST

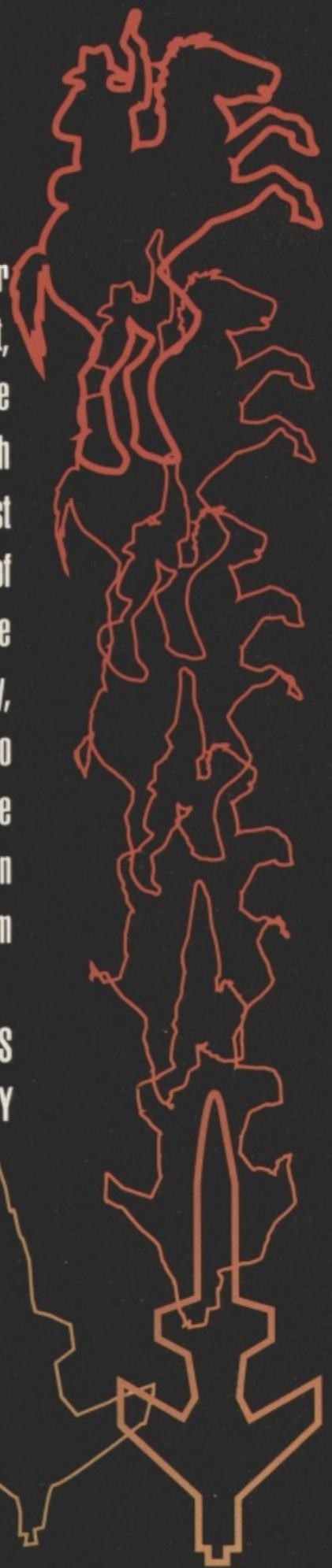

OCEAN SOFTWARE LTD,
6 CENTRAL ST, MANCHESTER,
M2 5NS.TEL: 061 832 6633
FAX: 061 834 0650

CONTENTS

ECTS Report	6
Fast Forward	8
Big in Japan	10
Sega City	14
Narly Nintendo	18
Atari Attack	20
RAZE Reviews	24
Competition	42
Import Reviews	58
Hot Slots	66
Pick a Stick	70
Competition	82



Bust your gonads and slag your fat
VIZ32

■ Amiga ■ Atari ST ■ IBM PC ■



One man and his dog mow a mob
SHADOW DANCER38

■ Amiga ■ Atari ST ■ Mega Drive ■

PICK A STICK!...70

You choose! RAZE has put together the most accurate, fact-packed and comprehensive buyer's guide to joysticks, joypads and controllers ever. Rigourously tested, the best hand-helds, table-toppers, and lap-lurkers are lauded. While the poor performers are pummelled.

ISSUE NINE

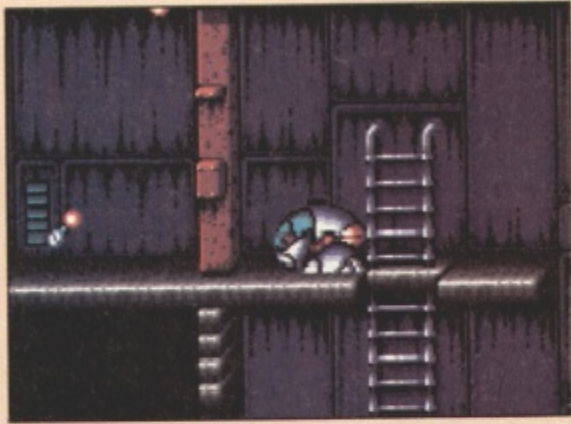

Dare to dabble with death in
SWITCHBLADE II.....46

■ Amiga ■ Atari ST ■

Preview INDEX

Consoles

ATARI LYNX	Block Out	21
GAME BOY	Balloon Kid	34
	Double Dragon	34
	HAL Wrestling	58
	Power Mission	60
	Rolan's Curse	60
	PC Frog	67
MASTER SYSTEM	Heavy Weight Champ	54
	Joe Montana's Football	40
	World Class Leaderboard	56
MEGA DRIVE	Phantasy Soldier III	58
	Shadow Dancer	38
	Verytex	58
NES	Gremlins II	28
PC ENGINE	SCI	62

16-Bit

AMIGA	Atomino	30
	Disc	48
	Jet Fighter II	50
	Quadrel	44
	Shadow Dancer	38
	Switchblade II	46
	Viz	32
ATARI ST	Atomino	30
	Disc	48
	Quadrel	44
	Shadow Dancer	38
	Switchblade II	46
	Viz	
IBM PC	Jet Fighter II	50
	Joe Montana's Football	40
	Life & Death II	24
	Spot	42



**PICK UP A
PALM-TOP...66**
Win a fabulous top-of-
the-range Atari Lynx
portable games console.

SOFTWARE SHOWDOWN

This map gives you some indication of just how big the finished *Rolling Ronny* is going to be. But you'll have to wait till September for it.



After surviving the infamous Boardman Vauxhall Cavalier, Les Ellis returned from the recent European Computer Trade Show a nervous wreck and clutching this report

VIRGIN

The Virgin stand collected quite a bit of attention for a few reasons. First, and most definitely least of all, was the fact that Jeremy Beadle was hanging about there. Second point of interest was the huge cutout of the Fat Slags from the Viz comic. Thirdly, and probably the main attraction judging by the faces of the members of the press, there was a woman wearing the most ridiculously short skirt that you could ever dream of.



This is *Rolling Ronny*, the first game to appear from the Virgin/Starbyte deal.

The latest news from Virgin is of their exclusive deal with German developer Starbyte. The first games to appear from this collaboration will be *Rolling Ronny*, *Sarakon* and *Warriors of Darkness*. *Rolling Ronny* is a cute, fun, arcade game where the eponymous Ronny has to run about town doing errands for people. The graphics are astounding, with screens packed full of colour and hundreds of little characters. There should be versions for all three 16-bit computers.

Sarakon is to be released on the Leisure Genius label in late May, with a three-format screening. The

game is basically another version of Mahjong, which Activision first brought over to the UK under the guise of *Shanghai*.

The last Starbyte release, *Warriors of Darkness*, is a long

way off yet. However, if Virgin's PR is anything to go by (which it isn't), then the game will be worth waiting for. Apparently, we'll be getting a stunningly illustrated fantasy arcade game.

Also being demoed at the show was 147 *3-D Snooker* from that cult author Archer Maclean (he of *Dropzone* and *IK+* fame). All kinds of shots are possible in what Virgin

are saying is the most realistic snooker sim yet. Let's hope they're not telling porkies, for we'll have to wait till September for its release.

US GOLD

With a dearth of Sega Master System releases (see *Sega City* on page 14), US Gold were proudly exclaiming that consoles are here to stay. Still, I managed to fight my way past the free sandwiches and coffee to find several 16-bit releases that looked easily as good as anything on the consoles.

US Gold's latest arcade conversion from the Capcom house is *Mercs*. Playing a hardened soldier, you must use your anti-terrorist training in a top secret operation for the US Government. While visiting a

Here come the cavalry to clear the beaches of the British lager lout. US Gold's *Mercs* should be out within the month.



central African country, the US President has been taken hostage by a group of terrorist extremists. So an elite group of mercenaries has been assembled to execute a lightning mission and snatch the President from under his captors' noses. The game has eight levels of pure arcade action and features a simultaneous two-player mode. Out soon on the Amiga and Atari ST for £25.99.

Roleplaying freaks among you will be enthralled to know that US Gold are releasing two new adventures. *Might and Magic III* is just around the corner for PC owners, and features an evil nemesis called Sheltem who has decided to annihilate the islands which you inhabit. Of course you and a party of friends band together and trek off through the wilderness to give this Sheltem a taste of his own magic.

The second RPG is *Planet's Edge: The Point of No Return*. Earth has vanished and as one of the last remaining survivors of the human race stuck on a moonbase it is up to you to find out what happened to it. There are over 60 worlds to explore and loads of puzzles to keep you going.



US Gold's next Capcom coin-op tie-in is *Mercs*, an action-packed blast-'em-up combining all the best elements of the great arcade hits. Here you get to the end of level one and are confronted by a monstrous piece of military hardware. Guns at the ready...

Release within three months.

US Gold were also plugging their new deal with Millennium (producers of *James Pond* and *Moonshine Racers*), with details of *Stormball* and *Tentacle* for early summer. Looking further ahead, US Gold hope to release the Millennium games *Strike Command*, *Shinto's Revenge*, *Robin Hood*, *Cybernetics* and *RoboCod*.

Before leaving the stand, I did sneak a look at an interesting AD&D game. *Shadow Sorcerer* is being promoted as a new concept in RPGs. The version I saw was a lot easier to control than most other games of the genre, using a *Populous* isometric viewpoint to control your party. The game is still very much work in progress, but by all accounts it's one to keep an eye on.



MIRRORSOFT

The least you would have expected here is a nice cup of Maxwell House, but Diet Coke awaits the thirsty visitor at the Mirrorsoft stand. Waiting to make its way onto a journalist's coffee-stained notepad here is news of another Turtles game. *Turtles II* will be based on the successful Konami four-player arcade machine. Probe, the people who recently did *Viz*, have landed the unenviable job of squeezing this mammoth game into the 16-bits. They promise that *Turtles II* will



Looks juicy, doesn't it. *First Samurai* features revenge, death, destruction and no Bart Simpson. Great potential, but will it fulfil it when *First Samurai* makes a public appearance this summer?

be infinitely better than the original computer game (not too difficult).

Also in the Mirrorsoft stable waiting to bolt is a new 3-D strategy roleplaying game called

Legend is Mirrorsoft's follow-up to the tremendously successful *Bloodwych*.

Drop Soldier. However, Mirrorsoft are keeping the reigns on the Amiga, Atari ST and IBM PC versions till winter 1991.

Other games worth a mention are *Duster*, a 3-D action and strategy futuristic farming game (I kid you not), and *Fire and Ice* (without Torville and Dean), an arcade run 'n' jump game featuring a large dog who has to guide his litter around a maze.

Legend (no tie-in with the film or the software house), from the makers of *Bloodwych*, uses both 2-D and 3-D in a world where happiness and joy are things of the past. *Legend* will be out at the end of the year on Amiga and PC. Another evil demon-fighting game, *First Samurai*, will be out a little sooner in autumn for all three 16-biters.

On the Cinemaware label, *TV Sports Baseball* will be out in the summer for the Amiga and IBM PC at £29.99. Following that is the ultimate Battle of the Sexes game, *Rollerbabes*, a mixture of rollerderby, hockey, wrestling, boxing, skateboarding and mud-wrestling.

Now - where was that Diet Coke?

coin-op. The game promises full 3-D graphics and stunning sound FX, and should be out in May for Amiga and ST.

A similarly impressive coin-op is *Thunder Jaws*, centred around a mechanical shark. As with most



ife as a courier never used to be like this. In the olden days, you could quite happily zip in and out of the traffic on your 50cc. Nowadays, the only way to get about is on water, and you constantly risk attack from helicopters and the like. Try your luck in Domark's *Hydra*, a conversion of the cracking coin-op.



Tengen games, there's a simultaneous two-player mode to double the fun. Amiga and Atari ST versions in June for £24.99.

Further into the future, Domark were prepared to reveal plans of *Pit Fighter* for October, *Race Drivin'* in November and *Ramparts* for release in January 1992.

Steerrrikkee! Yet another baseball game makes its way onto computer. However, Domark's *RBI Baseball* is a bit different from the norm because it features some great behind the scenes screens to liven up the gameplay.

Nintendo owners will also have a version, although Domark aren't having anything to do with that.

More conversions from Tengen are lined up, the most impressive being *Hydra*, based on the three-month-old



★ Psygnosis have some new releases for the autumn. *Agony* on the Amiga is a multi-level, magical, slashing game for £25.99. Also at that price, on the Amiga and ST, is *Barbarian II* (without Maria Whittaker) which features 2000 frames of animation, six levels, 50 different enemies and numerous attractive backdrops.

★ Arc, remember them, are releasing loads of stuff in the not too distant future. *Brute*, which is set in the future, is a fast moving action game where you must defeat the dark lords and protect the holy ones. Amiga and Atari ST versions soon.

★ Anyone remember *Encounter*, the fast-moving 3-D shoot-'em-up that wowed Atari 8-bit and C64 owners of yester-year? Well, Paul Woakes has dug up the old classic and given it a new lease of life on the Amiga and Atari ST. For such an old game and concept, it's a bit pricey at £20.42.

★ Gremlin have taken the best even further. *Lotus Esprit Turbo Challenge* was heralded as one of the best driving games ever. In October, on the Amiga, ST and PC, *Turbo Challenge II* will be released. Also across the 16-bit formats in November comes *Space Crusade*, programmed by the creators of *Hero Quest*.

★ French software company, Infogrames have a new batch of releases coming up. *Billiards Simulator II* features American and French rules plus a billiard player's nightmare, an eight-sided table! You can either learn the rudiments of the game in practice mode or play against another opponent with the two-player option. Out now for £24.99 on Amiga and Atari ST.

★ Elite have been having a quiet time of it recently, but on June 26 they release the 16-bit versions of the Sega coin-op *Last Battle*. The prices are £25.53 for the Amiga and PC versions and £20.42 for the ST version. Also, the footy game *European Championship 1992* will be out in autumn 1991(!), converted from the Tecmo coin-op *World Cup 90*(!!).

DOMARK

Ahh, the Domark stand and the first proper cup of coffee of the day, soon to be followed by some hot news. Now it seems that Domark are getting into consoles too. The rapidly expanding company were pleased to announce news of *Prince of Persia* and *Super Space Invaders* on the Master System. The launches in September and November respectively will coincide with the computer versions, also to be handled by Domark.

RBI (Runs Batted In) *Baseball* is coming out at the end of May on Amiga, Atari ST and IBM PC at £29.99. It will feature all the excitement of a real baseball match with some extras to add to the fun.

FLIGHT SIM IN ACTION SCANDAL!

Les Ellis investigates



Bandit on your six. Better make some quick movements or Chuck Yeager ain't gonna be the only Charlie around here.



Old Chuck Yeager has been around a bit. In fact almost as long as that other chubby chappy, Arnold Palmer. But whereas Arnold likes to take things at a slow, leisurely pace, Chuck is a man with a need for speed.

Chuck Yeager has already appeared in his own computer sim, *Chuck Yeager's Advanced Flight Trainer*, but the release of *Chuck Yeager's Air Combat* on the PC heralds a new age in flight sims. *Air Combat* still contains all the graphics and technical accuracy of all other flight sims, but it also has more than its fair share of action-orientated content.

The reason for this explosive concoction of game styles is that the programmer, Brent Iverson (*LHX Attack Chopper*), collaborated with the great man himself to bring his excitement and enthusiasm onto the screen for all to experience.

There are over 50 missions included, taking place in WWII, Korea and Vietnam. The range of aircraft is also immense, both on the allied and enemy sides. The game is packed

with dogfights, which take up most of your flight time. And beginners needn't feel daunted for there are options which give you invincibility, infinite ammo and easy landings.

Visually, the game goes totally over the top. There are 20 different external views with full use of the 256-



colour VGA graphics. The 3-D creation routines run at a stunning rate, making the game a pleasure to play, rather than a chore. There's even a full-function VCR to replay those classic dogfights.

Chuck Yeager's Air Combat will be released from Electronic Arts on the IBM PC at the end of June for £29.99. The Amiga version should follow in the autumn.

can be done in *Birds of Prey*.

There are 12 different types of combat mission to complete in any of the 40 planes. The game is also totally true to real life. For instance, say you blow up an enemy runway, you can watch the enemy repairing the runway and then observe the enemy hangar opening up to allow an aircraft to roll out and take off.

With fast 3-D graphic routines and stunningly realistic sound, *Birds of Prey* takes simulations to a new height of perfection. The 1Mb Amiga version will be out in July (hopefully) priced at £29.99, with the Atari ST and IBM PC versions following later in the year.

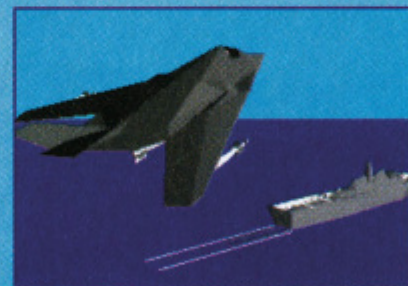

The infamous F-117 Stealth Fighter: one of the most expensive aircraft ever made, invisible to radar, it goes in, does the job and gets out before the enemy know what's hit them. Note the missiles slung underneath, these act exactly as the real things. If the same applies to the aircraft you can find out why this plane is nicknamed the Wobblin' Goblin.

GAME ALMOST FINISHED SCANDAL!

Electronic Arts' *Birds of Prey* has been called quite a few things in its time. The huge project started out as *F-117A Aggressor* and was planned for release in 1989. As the release date grew nearer and the game got larger, it was obvious that *F-117A Aggressor* wouldn't make it out in time. Still, Argonaut, its designers and programmers, aren't ones to admit the fact that it was late, so they changed the name to *Hawk* and pretended it was a whole new game. Yet again the release date in 1990 flew by, so they changed the name to what we now know it as, *Birds of Prey*. But whatever

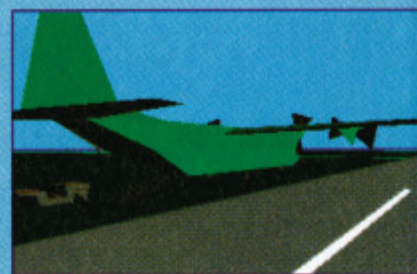

Now isn't that just typical! You leave your jeep with a parking attendant at Heathrow who not only parks it next to a runway, he also nicks the wheels! Let's just hope that this cargo drop from the Hercules contains a few spare ones that fit your axles.

er you call it, this is one massive game. The reason - excuse - for this time delay, has been due to the programmer's insistence on making the game better than anything else on the market. Indeed, Electronic Arts, who have funded this project for almost four years, claim that anything that can be done in real life

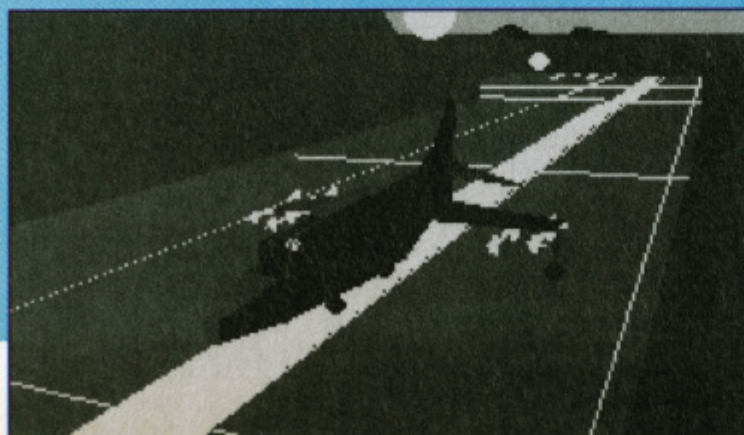

PREVIEW POSTSCRIPTS

★ Just released from System 3, the home of *Last Ninja*, is *Myth*, an arcade action adventure through four massive levels. There are loads of puzzles and even more enemies to overcome. If it reaches the same success as it had on the C64, then we 16-biters could be in for a treat. Amiga and Atari ST versions soon for £25.99.

★ On Line Software, no relation to Sierra, have released *Battle Bound* on the Amiga and Atari ST. The CD specialists hope this disk-based, magical arcade beat-'em-up will whet our appetites for when they get to work proper on the CD-TV. Just £24.99 will make you whet.

★ Ocean have signed up the suicidal Psygnosis game *Lemmings* for release on the NES and Game Boy. They are hoping to get it out for Christmas, although red tape may mean it could be 1992 before we see it. Ocean also have a couple of film licences for the NES. *Hudson Hawk*, licensed from the Bruce Willis film, should be out for Christmas, while the conversion of Spielberg's Peter Pan film *Hook* is scheduled for Easter 1992.

★ Activision are back in action. July releases on Amiga, ST and PC include *R-Type II* and *Beast Busters*, both from great coin-ops. These are to be followed by Amiga and ST versions of *Deutrosand*, a PC version of *F-14 Tomcat*, *Hunter* on Amiga and ST, and *Ghostbusters II* and *Rad Gravity* on the Game Boy.

★ For those Nintendo owners who earn £100,000 a year and drive a Ferrari Testarossa, Mindscape have come up with the *Miracle Piano Tutor*, retailing at £249.99. This four-octave keyboard plugs straight into your NES and, with the *Miracle Piano Teaching System* cartridge, you can create magnificent sounds in the comfort of your own home. A full review when Cole Trickle can afford to buy one.

A FORCE OF ONE ON THE FAST LANE TO HELL...



THALAMUS



ARMALYTE

By Arc Developments



AMIGA and ATARI ST £25.99

YOU'RE ON YOUR OWN!

Your ship may be state-of-the-art — but can one small craft survive the mighty savagery of the Aalans? You have no choice: you're the only survivor of Armalyte Force — destroyed on the fringes of Delta Space. And if you don't eliminate the alien horde Earth will die. Enter the forbidden zone — give 'em hell! Armalyte is classic shoot-'em-up action on five stunning levels of annihilation galore — a brilliant blaster to knock others for six!

BIG IN

"Rimujin noriba wa doko desu ka?" were the words uttered in a slow slurred saki-induced manner by our man on the Japanese streets, Shintaro Kanaoya. Having uncovered Sega's dastardly plot to paint the Game Gear white, been witness to the first PC Engine game to feature a combination ROM/RAM cartridge, and walked off with the blue print for the Super Famicom TV, he was in need of silencing. Well, he managed to shake off his pursuers, and here's his story...

Minisama yokoso. Have I got a treat for you this month! Big in Japan is a whopping three pages. Two pages dedicated to the usual comprehensive collection of explosive previews, exclusive hardware news, and general fact-packed information regarding the software scene in Japan. And a further page crammed with the very latest tricks, tactics and under-

3-D backgrounds, four different skill levels, auto fire as standard if desired, new weapons – the works!

All the elements of the original are to be found in *Super R-Type*. However, the aliens are weirder, their weapons bigger and wackier, and the action faster and more frantic. What more could you ask for? Try *Dungeon Master* in September... This

A scene from the graphically intense PC Engine CD-ROM game *Cobra II*. With over 3000 graphical scenes it could well be a real eye pleaser, but will there be any gameplay?



hand dodges for all the top consoles. Whichever way you look at it, you're a winner if you read Big in Japan.

Let's start this month with the Super Famicom. *Super R-Type* is the game to look out for. Released in July, it will demolish all other shoot-'em-ups. For those of you with good memories, *R-Type* caused a stir when it came out on the PC Engine a few years ago. Indeed, it is a very good game. However, *Super R-Type* will make it pale into a very pale thing indeed. For a start, it features a completely new scenario. Impressive

How about this for a neat idea? The Super Famicom TV lets you plug in any Famicom game into the cartridge slot on top of the monitor while the controllers plug into sockets on the front panel. And when you've had enough of *Final Fight*, you can watch the TV.

maze and monsters mash-'em-up is close to the numerous other versions, although it's rumoured to have a different dungeon. More sleepless nights...

A game that was a huge success on the more serious (which some might unkindly but quite correctly call more boring) computers makes its way onto the Famicom this Summer. The game: *Lagoon*.

Sim City's out now. Nothing much has changed from the other computer and console versions. However, there's now a character called Doctor Light who's got green hair and glasses and offers advice (in Japanese). Old Doctor Light lets you build things called Surprises for \$100. You get

something beneficial at the end of it, but as its title suggests it's always a surprise. There are eight things it could be:

- The mayor's house which doubles surrounding land values.
- Fun fair which gives you \$200



- income.
- A zoo which gives you \$100 income.
- A station which also provides you with \$100 and raised land values.
- Bank, from where you can borrow \$300. It will also encourage people to live in the vicinity.
- Casino, \$500 income.
- Large police station which has the effect of one and a half police sta-

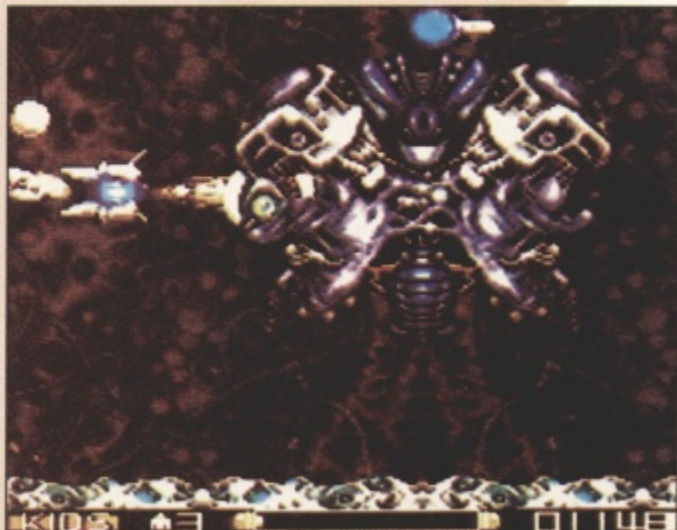

Super R-Type on the Super Famicom features a shotgun laser which acts like a shotgun in that the shots disperse and almost form a shield of bullets around you.



JAPAN

The attention to detail in the Mega Drive version of *Bonanza Brothers* is fantastic and will cause a few wry smiles. Try stepping on a broom for example (just think back to all those cartoons in which that happened) or even a coke can.

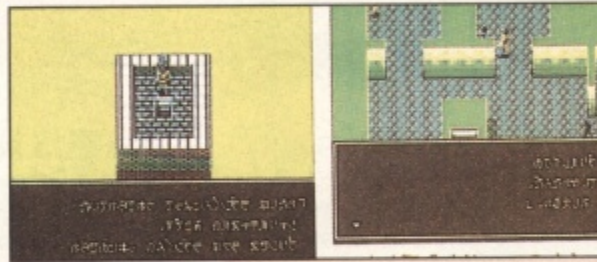

By the way, anyone who asks the advice of the caddy in *Hole In One* and is dismayed by the fact that it's all in Japanese, don't be. It says things like "Hit the ball straight and it'll go in" and "Watch out for the wind". In other words, the caddy is completely useless.

Looking ahead there's something called *Hyper Zone*. It's dubbed an arcade game of the future, but is really a race game like *F-Zero*. The difference being that you're in the air rather than on the ground.

cent of the classic *Zaxxon* shoot-'em-up and really does look very impressive with its solid isometric 3-D. *Arcs* is another of the ever popular breed of action RPGs like *Lagoon*, *Dungeon Master* and *Drakkhen*. There are four characters to choose from; two men and two women.

I've mentioned it before, but the fantastic *Bonanza Brothers* is just around the corner. Word is, it has a two-player simultaneous mode so there's no reason for it not to be as addictive as the arcade version.

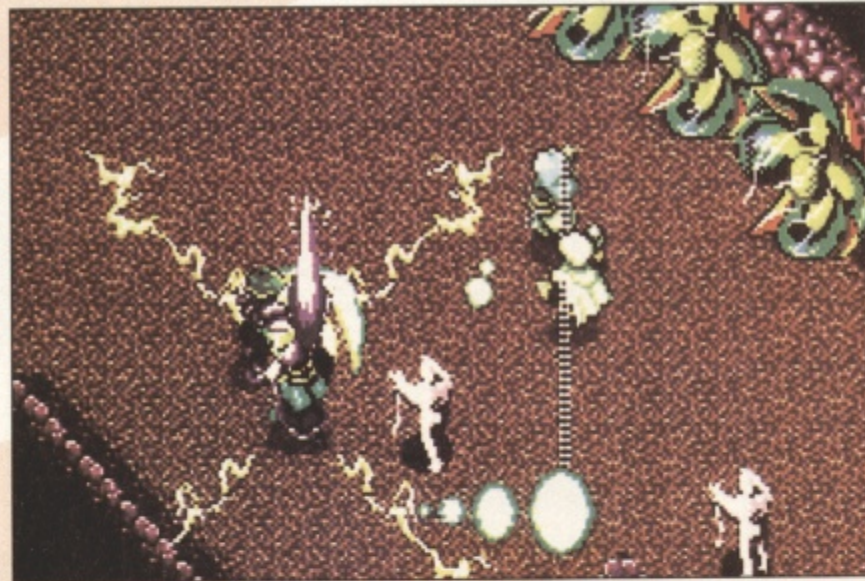

LESS FAT TOO

Mega Drive time. *Marvel Land* is repulsively cute and colourful. It's a jolly arcade adventure with clever puzzles and so on, but is disgustingly cute.

Far better for your street cred is *Alien Storm*. Sickly-looking pink aliens with demon heads get blasted by a scantily-clad woman carrying a laser bazooka. All this plus a 3-D shooting scene in a supermarket.

More killer mayhem (this time with a supernatural twist) can be found in *Arcs Odyssey*. The game's a two-player simultaneous action RPG where the screen scrolls diagonally most of the time. It's all very reminis-

Arcs Odyssey on the Mega Drive is an arcade action RPG; one of the new breed games in which the emphasis is on action rather than boring still screens. Much of the game is played on a diagonally-scrolling background.

Very briefly, the GG *Shinobi* is unsurprisingly the Game Gear version of *Shinobi*. It's the same game as before but on a smaller machine. To come are the classic *Mappy* and the politically insensitive, *Good Luck Gorby*. The point in *Gorby* is to get resources and food to the people that need them. I don't know that such a serious issue should be treated in a fun manner, but I guess it just shows how popular Mikhael is to all but the Soviets.

TOOT IF YOU DID IT

Onto the PC Engine. The two that have attract attention this month are *Cobra II* on CD-ROM, the sequel to the adventure game in which no matter how hard you tried you couldn't die, and *Populous*.

Cobra II is set for release in June. While the graphics look great, I'm still sceptical about the playability. There are 3000 graphical screens, but that alone doesn't make a game. I've a feeling that it is just a retelling of one of the early *Cobra* comics (which it is based on) and not an interactive game.

The only significantly different thing about the PC Engine *Populous* is that it is the first game to have to use a combination ROM and RAM card. Because of the amount of information *Populous* has to cope with, it couldn't all be dealt with in the PC Engine's small RAM size. Subsequently, more RAM was added on the actual card which makes it look slightly bulkier, but is definitely eye catching. Other than that, no change. After all, would you put a flower in Mona Lisa's hair. No, which goes to show you can't improve on a masterpiece.

Speaking of masterpieces, two *Tetris* clones are coming soon: *Columns* and *Hatris*.

A fond farewell until next month. But just before you go, flip over the page for a huge collection of hints and tips for the very latest Japanese console releases. Abayo.



tions.

● Windmill, \$100 income.

Incidentally, the monster in the Tokyo scenario is rumoured to be Mario. Attack of the Fat Italians? A 'B' movie in the making.

Finally, on the *Sim* subject, *Sim Earth* is due to make an appearance

For those of you with Japanese Mega Drive, you can now buy an adaptor that enables you



to play American Sega Master System games. What's the point... Much more useful is the soon-to-be-released adaptor that lets you play Master System games on the Game Gear. Of course, this device hasn't been given Sega's blessing

around September time.

Another non-Japanese game is *Drakkhen*. Released a week after my birthday (which is May 17th, so please send cards and presents to Shintaro Kanaoya c/o RAZE...), it will be almost identical to the other versions.

SNOW WHITE AND THE SEVEN GGs

The Game Gear has been re-released in Japan! You can now buy it in dashing white complete with a white carrying case and a TV Tuner; all this for £140. Ho hum.



If you haven't noticed yet, RAZE has gone absolutely tips crazy this issue... so too, it seems, has Shintaro Kanaoya. In an astonishing fit of generosity, our man in Japan has unplugged himself from the saki drip and come up with a superb collection of tricks and tactics for a wealth of Japanese console games. And he's also full of Eastern promise; "these are the biggest, the best, the latest, and the most exclusive tips you'll find." Er, thank you Shintaro. Remember; RAZE leads, others follow.



PARASOL STARS
PC Engine

Fancy 99 credits? A lot of luck is needed to get this most desirable present. Get the rainbow-coloured necklace when one appears (be warned, this is hugely rare). Next get the three stars. Now all you have to do is defeat the end-of-level boss and collect a large coin. Normally this coin would ¥500, but by following this procedure it will be a ¥100,000 coin. Proceed to the next level and you'll have 99 credits.

PARASOL STARS
PC Engine

On the title screen, hold down buttons I, II and DOWN on the pad while pressing RUN. You will enter a sound mode test.

DOWNLOAD II
PC Engine

There are a number of useful options tucked away that enable you to select the start level, choose the number of lives, and listen to all in-game music. To get to the hidden menu press the following from the title screen: SELECT, I, II, I, II, I, II, I, II, I, II, SELECT.

BIG RUN
Super Famicom

For a sound test mode, insert both controllers and do the following on the second controller: press B four times, X four times, Y four times, A four times, B four times, X four times, Y four times, A four times. Then press L and R to go back and forward through a tune.

WRESTLE BALL
Mega Drive

Choose Hearty Boscers for yourself and enter any of the following on the password section:
ONCAI - Kung Fu
CYZSQ - Muay Thai
NATBR - Oriental Sumo Grapplers
FRKWM - USA martial arts team

SAINT DRAGON
PC Engine

Switch off the console, hold UP and turn on the Engine. Start as usual and you'll find you're completely indestructible.

AVENGER
PC Engine

Enter the following sequence twice on the title screen for indestructibility: UP, RIGHT, DOWN, LEFT, II, UP, LEFT, DOWN, RIGHT, I.



GAIN GROUND
Mega Drive

For a hidden round select feature, go to the option screen and press A, C, B, C. A round select should appear below sound test.

BATTLE GOLFER
Mega Drive

To access a sound test mode, hold down B on the title screen and press START.

ALESTE
Mega Drive

Press RESET ten times on the title screen, hold the diagonal LEFT and DOWN, and go to the options screen. You will find Round rather than Sound in the menu.

ALESTE
Mega Drive

To gain 20 options (a weapon of sorts), pause the game, press UP three times, DOWN three times, LEFT three times, RIGHT three times, C, C, B, A. You can repeat this indefinitely.

DARIUS III
Mega Drive

To get a sound test facility enter ZTT on the high score table.



HOLE IN ONE
Super Famicom

Enter Music as your password to get to a sound test mode.

DYNAMITE DUKE
Mega Drive

On the title screen, press C ten times followed by START to be able to change almost everything about the game.



FINAL FIGHT
Super Famicom

Here's a tip that's going to annoy players of this phenomenal game. Go to the option mode (achieved by holding down the left button on top of the controller) and press START. Go to the sound option and choose 99. Then exit and start normally. You will now have a two-player simultaneous game. Why the hell wasn't this included at standard? Swines...



BOMBER MAN
PC Engine

Enter RWOOHVVV as your password to get to the last level and have level 13 firepower (firepower is only supposed to go up to level five).

Win a Honda Cub!

This must be the most advanced off-road bike there is! It's automatic, so it's easy to ride, and its lightweight design and futuristic styling make it stand out from the crowd! The Cub would cost you £1800 to buy, but we're giving one away!!



0898 404621

Win a Honda MT 50S Moped!



The MT50S Honda is the best bike for any 16 year old who wants to hit the road in style!! It has an air-cooled 49cc 2-stroke engine and a Motocross style frame, seat and tank! To buy it you'd have to pay £1300, but 1 phone call and it could be yours!

0898 404622

Win a Kawasaki JS440 Jetski!



The Kawasaki JS440 is one of the best Jetskis you can buy at a cool £2500, but you could win one!! Jetskiing is going to be the trendy sport of this Summer, and you could be there first with our brilliant competition!!

0898 404623

Win a SIMPSONS Pinball Machine!



This Pinball is no under-achiever, it's a Simpsons game! Yup, people all over the country have been flipping over this machine, the biggest pinball craze in years! And if you fancy pocketing this £2500 prize, then just get on the ball and call the number shown below!!



0898 404624

SEGA CITY

By Julian Boardman

Tips attack month, but still a bit of room for all your normal faves

Bit of a tips frenzy this month folks, but first of all some news about upcoming releases and work in progress for the Mega Drive and Master System.

Electronic Arts are going a bit mad with two conversions from Amiga and PC onto the Mega Drive. *King's Bounty* and *Centurion* will be familiar to anyone who owns a PC and head up EA's effort to become one of the leading names in roleplaying and strategy for the Mega Drive. There is a huge gap out there for such games, particularly ones that don't follow the *Phantasy Star* menu-driven (and very limited) style of gameplay.

King's Bounty sets you up as a bounty hunter under the employ of

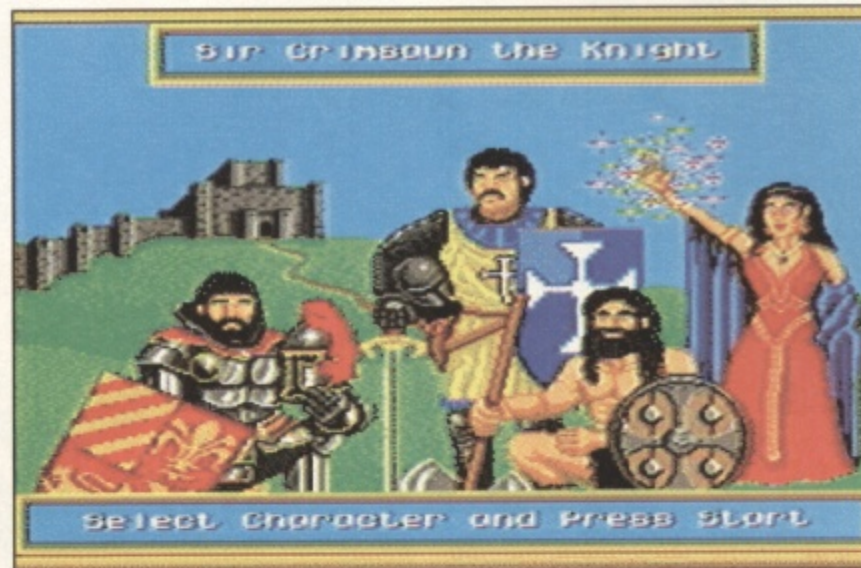
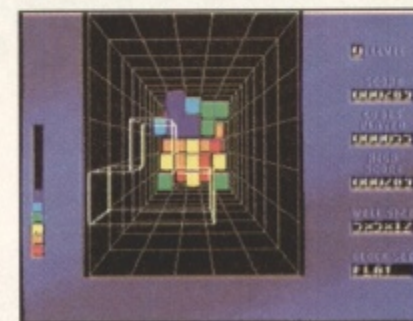
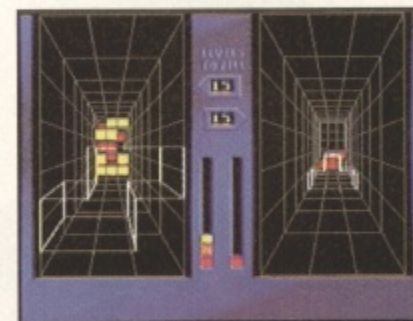
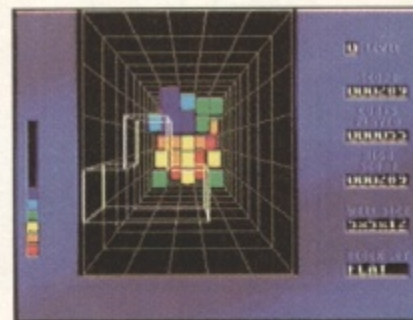

the head of the land. You get to wander about recruiting an army to take you into battle, collect clues and generally play detective to find the criminals that you have picked up the contract for.

Centurion places you at the head of a legion and it is up to you to help build up the Roman empire and your career with the ultimate aim of knocking off Cleopatra. You have to organize games, collect taxes and mastermind military campaigns to become successful.

Coming soon is another puzzle game that looks set to become a bit of a cult. It is called *Block-Out* and is played in a *Welltris* like pit. The difference is that instead of being flat shapes, they are 3-D blocks. The object is to make a solid level so that it disappears and you therefore don't get anywhere near the top and into the game over area. It's basically a variation on a well-worked theme but that said, it is VERY addictive.

Domark are also dipping their toes into the Sega pond with two planned conversions for the Master System. First up is the highly-acclaimed



GOT PILES?

Have you got problems with what to do with those piles of cartridges that manage to fill up the living room every time you get your Mega Drive out to play? Does your mother go skitz when she spills your dad's tea on the cat from tripping over that "difficult" pile of carts? Have you nearly gone head first into the telly as you skilfully tried to leap over the mound of abandoned cases scattered across the carpet? If so, then do not fear. Lift, "the world's leading innovator" of home storage systems, has launched Playkit. It provides storage for up to nine carts and can be stacked or clipped together to make that "interesting" modern art display on the shelf. Playkit is available direct from Lift on (0296) 615151 at just £8.99.



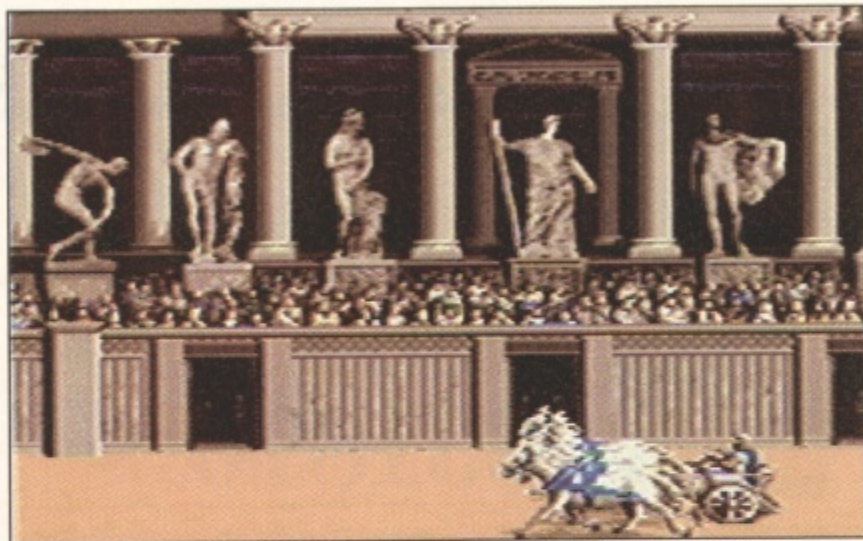

Prince of Persia that looked so good on the Amiga and PC with its realistic human animation. They're hoping to get it finished for September, although it could hold over to Christmas.

Following that in November will be *Super Space Invaders*, a direct conversion of the top-selling Taito coin-op. It brings the old idea up to date

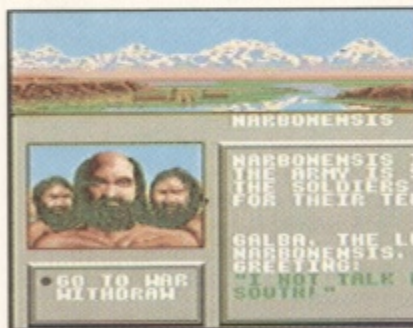

with power-ups and so on, but keeps the original's addictive qualities. It is hoped that there will be a simultaneous launch with the other computer versions which Domark are also working on. All this work in being done by The Kremlin, in Surrey, Domark's own out-of-house developers.

Rumours that the Game Gear is

just a portable Master System may not be a load of old cobblers after all. Thanks to American chappies Direct Distributors Inc you can now buy an adaptor that allows you to plug those MS carts into the Game Gear and play *Alex Kidd* to your heart's content. You plug your cart into this thing and then plug the whole caboodle into the cartridge port on the Game Gear. It works like the Powerbase converter on the Mega Drive, and is available for around £30. Contact Stephen Scholfield at 1491 Boston Post Road, Old Saybrook, CT 06475 USA. Or you could go for Harry Ruppenicker at Gottseg 157 Koeln, 5000 Koeln 41 Germany.

SONIC'S ACE

Sonic the Hedgehog is ace – and that's official! I managed to get a sneak preview at a trade show last month and it is truly superb. Excellent graphics that rank up there with *Mickey Mouse* and gameplay that is even better. All I can reveal now is that it is the way Sonic moves that provides most of the entertainment and brings a whole new dimension to the world of arcade adventures. Look out for full review next issue.

AFTERBURNER II

Mega Drive

To be able to select your starting level, hold down buttons A, B, C and START during the title screen. When the carrier appears, you'll be able to select the start level by pressing LEFT and RIGHT.

Also, when you are reloading weapons, press the following buttons to gain a maximum payload of 100 missiles.

- Stage 3: LEFT+B
- Stage 5: RIGHT+B
- Stage 9: B
- Stage 11: RIGHT+B
- Stage 13: LEFT+B
- Stage 16: RIGHT+B
- Stage 19: B
- Stage 21: RIGHT+B

KLAX

Mega Drive

If you thought *Klax* was tough already, try this cheat to make it even harder: hold UP-LEFT and A, B and C then press START on the title screen.

DANGEROUS SEED

Mega Drive

To get to expert mode, press UP, DOWN, LEFT, LEFT, RIGHT, RIGHT, UP, DOWN when the demo starts. The title screen letters should turn blue. You may have to try this a few times: a sound will acknowledge acceptance.

DARIUS II

Mega Drive

To be invulnerable to hits, press A, B, A, C, B, C, C, B, C, A, B, A on the title screen. "No Hit" should appear and you'll be able to start the game as usual.

RAINBOW ISLANDS

Mega Drive

To start the game with extra items, press the following on the title screen before playing:

UP, B, DOWN, LEFT, C, A, A – speed-up shoes.

UP, B, DOWN, LEFT, C, A, A, B – speed-up shoes and red bottle.

UP, B, DOWN, LEFT, RIGHT, C, A, A, B, C – speed-up shoes and red and yellow bottles.

GYNOUG

Mega Drive

For a sort of infinite credits hold down A, C and LEFT while Game Over appears. Do this every time you die and your credits will not decrease.

All this issue's tips come courtesy of *The Complete Sega Solution*.



10 COPIES OF THE COMPLETE SEGA SOLUTION UP FOR GRABS

★ Plus a free money-off voucher for every entrant!

Yes, it's true! You could be one of ten lucky winners to walk away with a copy of the fabulous hints and tips book, *The Complete Sega Solution*, for the Sega Master System and Sega Mega Drive. But there's more. Everyone who enters the competition automatically receives a £1-off voucher which is redeemable when purchasing *The Complete Sega Solution*. In short, everyone's a winner.

BOOK LOOK

In case you missed last month's *Sega City*, which ran a short story on *The Complete Sega Solution*, here are those details in full.

The Complete Sega Solution is a comprehensive collection of tricks, tactics and playing solutions for over 120 top Sega Master System and Sega Mega Drive games. However, it's more than that because each game is reviewed and rated so you know at an instance whether a game's worth adding to your collection.

In over 200 pages you'll discover secrets buried within games; infinite lives, hidden messages, level selects, bonus rounds, concealed stages, unlimited continues, programmer access codes, even games within games.

All the top games are featured, including the *Alex Kidd* series, *Arnold Palmer Tournament Golf*, *ESWAT*, *Gain Ground*, *Ghostbusters*, *Ghouls 'n' Ghosts*, *Golden Axe*, *Gynoug*, *James Pond*, *Mickey Mouse*, *New Zealand Story*, *Rainbow Islands*, *Ringside Angel*, *Shadow Dancer*,

Strider, *Tetris*, the *Wonder Boy* collection, and many more. A prize well worth having, you'll agree.

GIVE AWAY

To get your mits on this attractive book, you must answer three simple questions. Send your name and address together with the answers to "Book 'em, Danno", *RAZE*, Unit 3, 7 Back Street, Trowbridge, Wiltshire BA14 8LH. Get your entries in by June 24 or you could end up a book worm.

1. What is Sega's corporate motto?

- A. Creativity is life
- B. No Mario Bros here
- C. We love pudding

2. What is so striking about Alex Kidd?

- A. His 14-inch tongue
- B. His pointy ears
- C. His 14-inch platform shoes

3. What was the first Mega Drive game?

- A. Beauty and the Beast
- B. Altered Beast
- C. Shadow of the Beast

GAMEBOY

GAMEBOYALLEYWAY	20.00
AMAZING PENGUIN	25.00
BALLOON KID	25.00
BASES LOADED	25.00
BATMAN	25.00
NEW BATTLE BULL	25.00
NEW BATTLESHIP	25.00
NEW BEETLEJUICE	25.00
BOXXLE	25.00
NEW BUBBLE BOBBLE	25.00
NEW BUBBLE GHOST	25.00
BUGS BUNNY	25.00
NEW BUGS BUNNY II	25.00
NEW BURDAI DELUXE	25.00
CASTLEVANIA	20.00
CHASE HQ	25.00
NEW CHESS MASTER	25.00
COSMO TANK	25.00
NEW CURTIS STRANGE	
GOLF	25.00
DAEDALION OPUS	25.00
DEAD HEAT SCRAMBLE	20.00
DOUBLE DRAGON	20.00
DR MARIO	25.00
NEW DRAGON TAIL	20.00
DUCK TALES	25.00
FINAL FANTASY	30.00
FLIPALL	25.00
FORTRESS OF FEAR	25.00
GARGOYLES QUEST	20.00
GHOSTBUSTERS II	25.00
NEW GREMLINS II	25.00
HAL WRESTLING	25.00
NEW HARMONY	25.00
HEIANKYO ALIEN	25.00
HYPER LOAD RUNNER	20.00
NEW KUNG FU MASTERS	25.00
KWICK	25.00
LOCK AND CHASE	20.00
MALIBU BEACH VOLLEY	20.00
NEW MEGA MAN	25.00
MERCENARY FORCE	25.00
MOTOCROSS MANIA	20.00
NEMISIS	20.00
NFL FOOTBALL	25.00
NEW NINJA BOY	25.00
NINJA TURTLES	25.00
NEW OPERATION C	25.00
PAPERBOY	25.00
PENGUIN WARS	20.00
PIPEDREAM	25.00
PLAY ACTION FOOTBALL	25.00
NEW POWER MISSION	25.00
POWER RACER	25.00
QUARTH	25.00
NEW R-TYPE	25.00
REVENGE OF THE GATOR	25.00
NEW ROBOCOP	25.00
SHANGHAI	25.00
SIDE POCKET	25.00
SKATE OR DIE	25.00
SNOOPY	25.00
SOLO STRIKER	20.00
SPIDERMAN	25.00
SUPER MARIO LAND	20.00
TENNIS	20.00
WORLD BOWLING	25.00
NEW WWF ALL STARS	25.00

NEO GEO

BASEBALL STARS	149.00
CYBERLIP	149.00
MAGICIAN LORD	149.00
NAM 1975	149.00
NINJA COMBAT	149.00

RIDING HERO	149.00
SUPER GOLF	149.00
SUPER SPY	149.00
NEW WORLD BOWLING	149.00

MEGADRIVE

NEW AEROBLASTER	35.00
AFTERBURNER II	35.00
AIR DRIVER	35.00
ALEX KIDD	30.00
ALTERED BEAST	30.00
NEW AMBITION OF	
CEASER	40.00
ARNOLD PALMER GOLF	35.00
ARROW FLASH	35.00
ASSAULT SUIT LEYNOS	35.00
ATOMIC ROBOKID	35.00
AXIS FZ	30.00
BATMAN	40.00
NEW BATTLE GOLFER	35.00
BATTLE SQUADRON	40.00
BUDOKAN	40.00
BURNING FORCE	35.00
BUSTER DOUGLAS BOXING	35.00
COLUMNS	30.00
CRACK DOWN	35.00
CURSE	35.00
CYBERBALL	35.00
DAI SENPU (1943)	35.00
DANGEROUS SEED	35.00
DARIUS II	45.00
DARWIN 4081	35.00
NEW DICK TRACY	35.00
DJ BOY	35.00
DYNAMIC DUKE	30.00
ELEMENTAL MASTER	35.00
ESWAT	35.00
FAT MAN	35.00
FINAL BLOW	35.00
FIRE SHARK	35.00
FORGOTTEN WORLDS	35.00
GAIARES	45.00
GAIN GROUND	35.00
GENORD	35.00
GHOST N'GHOULS	45.00
GHOSTBUSTERS	35.00
GOLDEN AXE	35.00
GRANADA	35.00
NEW GYNOUG	35.00
HARD DRIVING	35.00
HEAVY UNIT	35.00
HELLFIRE	35.00
HORZOO ZWOR	30.00
INSECTOR X	35.00
NEW ISHIDO	35.00
JOE MONTANA FOOTBALL	35.00
JOHN MADDEN FOOTBALL	40.00
JUNCTION	35.00
NEW KAKE GI	40.00
KLAX	35.00
KUJAKU II	35.00
LAST BATTLE	35.00
MAGICAL HAT	35.00
MASTER GOLF	35.00
MEGA PANEL	35.00
NEW MICKEY MOUSE	35.00
NEW MIDNIGHT	
RESISTANCE	35.00
MOONWALKER	35.00
MUSHA ALESTE	35.00
MYSTIC DEFENDER	35.00
NEW ZEALAND STORY	35.00
PAT RILEY BASKETBALL	35.00
PHANTASY STAR II	45.00
PHELIOS	35.00
POPULOUS	40.00

ORDERS TAKEN
24 HOURS A DAY
TEL 0634 831870
FAX 0634 831971

ACCESS &
BARCLAYCARD
WELCOME



RAINBOW ISLANDS	35.00
RAMBO III	30.00
RASTAN SAGA II	35.00
REVENGE OF SHINOBI	35.00
RINGSIDE ANGEL	40.00
SHADOW BLASTER	35.00
SHADOW DANCER	35.00
NEW SONIC THE	
HEDGEHOG	35.00
SPACE HARRIER 2	35.00
NEW STAR CRUISER	35.00
STRIDER	45.00
SUPER HANG ON	35.00
SUPER HYDLIDE	30.00
SUPER LAEGUE BASEBALL	35.00
SUPER MONACO G/PRIX	35.00
SUPER REAL BASKETBALL	35.00
SUPER SHINOBI	35.00
SUPER THUNDERBALDE	35.00
SWORD OF SODAN	36.00
SWORD OF VERMILLION	45.00
TARGET EARTH	35.00
TATSUJIN	35.00
THUNDERFORCE II	35.00
THUNDERFORCE III	40.00
NEW TIGER HELI	35.00
TOMMY LASORDA	
BASEBALL	35.00
TRUXTON	35.00
VOLFIED	35.00
WHIPRUSH	35.00
WONDERBOY III	35.00
WORLD SOCCER	35.00
NEW WRESTLEBALL	35.00
XDR	35.00
ZANY GOLF	35.00

MASTER SYSTEM

ACTION FIGHTER	12.95
AFTERBURNER	29.95
AIRIAL ASSAULT	29.95
ALEX KIDD LOST STAR	19.95
ALEX KIDD HIGH TECH	24.95
ALEX KIDD MIRACLE WORLD	24.95
ALEX KIDD SHINOBI WORLD	29.95
ALIEN SYNDROME	24.95
ALTERED BEAST	29.95
AMERICAN BASEBALL	29.95
AMERICAN PRO FOOTBALL	29.95
ASSAULT CITY	29.95
ASTRO WARRIOR	24.95
AZTEC ADVENTURE	12.95
BANK PANIC	17.95
BASKETBALL NIGHTMARE	29.95
BATTLE OUTRUN	29.95
BLACK BELT	24.95

C & N CO

354 HIGH STREET,
CHATHAM, KENT

0634
831870

BLADE EAGLE 3D	29.95
BOMBER RAID	29.95
CALIFORNIA GAMES	29.95
CAPTAIN SILVER	29.95
CASINO GAMES	29.95
CHASE HQ	29.95
CHOPLIFTER	24.95
CLOUD MASTER	29.95
CYBORG HUNTER	24.95
NEW DANAN JUNGLE	
FIGHTER	29.95
DEAD ANGLE	29.95
DOUBLE DRAGON	29.95
DOUBLE HAWK	29.95
DYNAMITE DUX	29.95
NEW E-SWAT	29.95
ENDURO RACER	10.95
F-16 FIGHTER	17.95
FANTASY ZONE	12.95
FANTASY ZONE II	24.95
FANTASY ZONE THE MAZE	24.95
NEW FIRE AND FORGET II	29.95
GALAXY FORCE	29.95
GANGSTER TOWN	24.95
NEW GAUNTLET	29.95
GHOST HOUSE	17.95
GHOSTBUSTERS	29.95
GLOBAL DEFENSE	12.95
GOLDEN AXE	29.95
GOLFMANIA	32.95
GOLVELLIUS	29.95
GREAT BASEBALL	24.95
GREAT BASKETBALL	24.95
GREAT FOOTBALL	24.95
GREAT GOLF	24.95
GREAT VOLLEYBALL	24.95
NEW IMPOSSIBLE	
MISSION	29.95
NEW INDIANA JONES	29.95
KENSEIDON	29.95
KUNG FU KID	24.95
LORD OF THE SWORD	12.95
MAZE HUNTER 3D	29.95
NEW MICKY MOUSE	29.95
MIRACLE WARRIOR	32.95
MISSILE DEFENCE 3D	29.95
MONOPOLY	29.95
MY HERO	17.95
NINJA	10.95
OPERATION WOLF	29.95
OUT RUN	29.95
OUT RUN 3D	29.95
NEW PAPERBOY	29.95
PENGUIN LAND	29.95
PHANTASY STAR	39.95
POSEIDEN WARS 3D	29.95
POWERSTRIKE	24.95
PRO WRESTLING	24.95

24 HRS ORDER LINES TEL: 0634

CONSOLES

Please make cheques Payable to **C&N Computers**
Price includes VAT
1st Class recorded delivery



PSYCHO FOX.....	29.95
QUARTET.....	24.95
R-TYPE.....	29.95
RAMBO III.....	29.95
RAMPAGE.....	29.95
RASTAN.....	29.95
RC GRAND PRIX.....	29.95
RESCUE MISSION.....	10.95
ROCKY.....	29.95
SCRAMBLE SPIRIT.....	29.95
SECRET COMMAND.....	12.95
SHANGHAI.....	24.95
SHINOBI.....	29.95
SHOOTING GALLERY.....	24.95
SHOOTING GAMES.....	24.95
SLAP SHOT.....	29.95
SPACE HARRIER.....	29.95
SPACE HARRIER 3D.....	29.95
SPELLCASTER.....	29.95
SPY VS SPY.....	17.95
NEW SUBMARINE ATTACK.....	29.95
SUPER MONACO.....	29.95
SUPER TENNIS.....	10.95
TEDDYBOY.....	10.95
TENNIS ACE.....	29.95
THUNDERBLADE.....	29.95
TIME SOLDIERS.....	29.95
TRANSBOT.....	10.95
ULTIMA 4.....	39.99
VIGILANTE.....	29.95
WANTED.....	24.95
WONDERBOY.....	24.95
WONDERBOY III.....	29.95
WONDERBOY MONSTER.....	29.95
WORLD GAMES.....	24.95
WORLD GRAND PRIX.....	12.95
WORLD SOCCER.....	24.95
Y'S.....	32.95
ZAXXON 3D.....	29.95
ZILLION.....	24.95
ZILLION II.....	24.95

NINTENDO

10 YARD FIGHT.....	24.95
ADVENTURES OF LINK.....	39.95
AIRWOLF.....	19.99
NEW BAD DUDES.....	34.99
BATMAN.....	39.95
NEW BAYOU BILLY.....	34.99
BIONIC COMMANDO.....	39.95
NEW BLACK MANTA.....	29.99
BLADES OF STEEL.....	29.99
BOBBLE BUBBLE.....	24.95
CASTLEVANIA.....	29.95
NEW DAYS OF THUNDER.....	39.95
NEW DEFENDER OF.....

THE CROWN.....	39.95
DONKEY KONG 3.....	19.95
NEW DONKEY KONG CLASSICS.....	19.95
DONKEY KONG JUNIOR.....	19.95
NEW DOUBLE DRAGON.....	34.99
DOUBLE DRAGON 2.....	29.95
DOUBLE DRIBBLE.....	24.99
DUCK HUNT.....	29.95
NEW DUCK TALE.....	39.95
EXCITEBIKE.....	19.99
NEW FAXANADU.....	29.99
FESTERS QUEST.....	29.95
NEW GAUNTLET II.....	39.95
GHOST AND GIBLINS.....	24.95
NEW GHOSTBUSTERS II.....	34.99
GOLF.....	24.95
GOONIES II.....	29.95
GRADIUS.....	24.95
NEW GREMLINS II.....	39.95
GUMSHOE.....	29.95
GUNSMOKE.....	24.95
GYROMITE.....	39.95
HOGANS ALLEY.....	29.95
ICE CUMBER.....	24.95
IKARI WARRIORS.....	29.95
NEW IRONSWORD.....	34.99
NEW JACK NICKLAUS GOLF.....	34.99
KID ICARUS.....	29.95
KUNG FU.....	24.95
LEGEND OF ZELDA.....	39.95
LIFE FORCE.....	24.99
MACH RIDER.....	29.95
MARIO BROS.....	19.95
MEGA MAN.....	34.95
NEW MEGA MAN II.....	39.95
METAL GEAR.....	34.95
METROID.....	29.95
NEW PAPERBOY.....	19.99
PINBALL.....	24.95
NEW PINBOT.....	29.99
POPEYE.....	29.95
PRO WRESTLING.....	29.95
NEW PROBOTECTOR.....	29.99
PUNCH OUT.....	24.99
NEW RAD GRAVITY.....	29.99
RAD RACER.....	29.95
RC PRO AM.....	29.95
NEW RESCUE.....	24.99
ROBO WARRIOR.....	29.95
ROBOCOP.....	39.95
RUSH N ATTACK.....	29.95
RYGAR.....	34.95
SECTION Z.....	24.95
SIMON'S QUEST.....	29.95
SKATE OR DIE.....	24.95
NEW SNAKE RATTLE & ROLL.....	24.99
SOCCER.....	24.95
NEW SOLAR JETMAN.....	29.99

SOLSMAN'S KEY.....	19.99
NEW STEALTH ATF.....	29.99
SUPER MARIO BROS.....	24.95
SUPER MARIO BROS II.....	39.95
NEW SUPER OFF ROAD.....	24.99
TENNIS.....	24.95
TETRIS.....	24.95
TIGER HELI.....	19.99
TO THE EARTH.....	24.95
TOP GUN.....	29.95
TRACK & FIELD 2.....	29.99
TROJAN.....	24.95
NEW TURBO RACING.....	34.99
TURTLES.....	34.99
URBAN CHAMP.....	24.95
WILD GUNMAN.....	29.95
WIZARDS AND WARRIORS.....	29.95
NEW WORLD CUP.....	29.99
NEW WORLD WRESTLING.....	34.95
WRECKING CREW.....	29.95
XEVIOUS.....	24.95

GAME GEAR

COLUMNS.....	30.00
DRAGON CRYSTAL.....	30.00
G-LOC.....	30.00
PENGO.....	30.00
NEW PSYCHIC WORLD.....	30.00
SUPER MONACO.....	30.00
WONDERBOY.....	30.00

ATARI LYNX

BLUE LIGHTENING.....	29.95
CALIFORNIA GAMES.....	29.95
CHIPS CHALLENGE.....	29.95
ELECTRO COP.....	29.95
GATES OF ZENDECON.....	29.95
GAUNTLET III.....	29.95
KLAX.....	29.95
MS PACMAN.....	29.95
PAPERBOY.....	29.95
RAMPAGE.....	29.95
ROADBLASTERS.....	29.95
RYGAR.....	29.95
SHANGAI.....	29.95
SLIME WORLD.....	29.95
XENOPHOBE.....	29.95
ZALOR MERCENARY.....	29.95

SUPER FAMICOM

ACTERISER.....	45.00
NEW BIG RUN.....	45.00
BOMBUZAL.....	45.00
F-ZERO.....	45.00
FINAL FIGHT.....	45.00
GRADIUS III.....	45.00
NEW HOLE IN ONE.....	45.00
PILOT WINGS.....	45.00
POPULOUS.....	45.00
SUPER MARIO WORLD.....	45.00

PC ENGINE

AFTERBURNER II.....	35.00
ALTERED BEAST.....	35.00
ATOMIC ROBOKID.....	35.00
BARUMBO MAN.....	35.00
BATMAN.....	35.00
BLOODY WOLF.....	35.00
NEW BOMBERMAN.....	35.00
NEW BURNING ANGEL.....	35.00

CHAN & CHAN.....	30.00
CHASE HQ.....	35.00
NEW CYBER COMBAT POLICE.....	38.00
CYBERCROSS.....	30.00
DEEP BLUE.....	30.00
DEVIL CRASH PINBALL.....	35.00
DIE HARD.....	35.00
DON DOKO DON.....	35.00
DRAGON SPIRIT.....	30.00
DRUNKEN MASTER.....	30.00
DUNGEON EXPLORER.....	30.00
FANTASY ZONE.....	30.00
FINAL BLASTER.....	35.00
FINAL LAP.....	35.00
FORMATION FOOTBALL.....	35.00
GALAGA 88.....	30.00
GAMOLA SPEED.....	35.00
GUNHEAD.....	35.00
HEAVY UNIT.....	35.00
HELL EXPLORER.....	35.00
NEW HURRICAN.....	35.00
IMAGE FIGHT.....	35.00
KLAX.....	35.00
KNIGHT RIDER.....	30.00
LEGENDARY AXE.....	35.00
LEGENDARY AXE II.....	35.00
MOTOROADER.....	30.00
MR HELI.....	35.00
NEW ZEALAND STORY.....	35.00
NINJA SPIRIT.....	35.00
NINJA WARRIORS.....	30.00
OPERATION WOLF.....	35.00
ORDYNE.....	30.00
OVER RIDE.....	35.00
PACLAND.....	30.00
PC KID.....	35.00
POWERDRIFT.....	35.00
PSCHO CHASER.....	30.00
R-TYPE 1.....	30.00
R-TYPE II.....	30.00
RABIO LEPUS SPECIAL.....	35.00
RASTAN SAGA II.....	35.00
ROCK ON.....	30.00
SHINOBI.....	30.00
SON & SON II.....	30.00
NEW SON OF DRACULA.....	35.00
SPACE HARRIER.....	30.00
SPLATTERHOUSE.....	35.00
SUPER STAR SOLDIER.....	35.00
TALES OF MONSTER PATH.....	30.00
TATIO BIKE RACING.....	35.00
NEW THUNDERBLADE.....	35.00
TIGER HELI.....	35.00
NEW TOY SHOP BOYS.....	35.00
VICTORY RUN.....	30.00
VIGILANTE.....	30.00
NEW VIOLENT SOLDIER.....	35.00
W-WING.....	35.00
WALLABY.....	38.00
ZIPANG.....	35.00

CONSOLE PRICES

MEGA DRIVE + FREE GAME.....	£159.00
LYNX.....	£ 89.00
GAMEBOY.....	£ 69.99
SUPER FAMICOM.....	£P.O.A.
MASTER SYSTEM.....	£P.O.A.

**PRICE INCLUDES VAT
BUT PLEASE ADD £5.00
p&p PER CONSOLE.**

34 831870 FAX 0634 831971 24 HRS

NINTENDO narly

In celebration of RAZE's tiptopic issue, here come two pages packed with cheats, hints, tips and solutions

SUPER MARIO WORLD

Super Famicom

There are more secret rooms than real ones in this fabulous Mario game. **Jason Clotworthy** from Peckham reveals a few of them. In the second stage of world two (the underground cavern), jump into the second green tube (above you), dodge the American footballer and get the empty shell. Now take the shell back to the four yellow blocks and kick it up to the highest block. You will now reveal a vine which you should climb to collect a key. Take this to the keyhole. Now you can enter the stage on the left of the start map and turn the empty green boxes into full ones. After doing that, go back to stage one of world two where a surprise secret stage awaits you. Later on in world two there's a warp to world seven, although Jason won't tell how to get there – yet...

To get nine lives, start the game with two players. When on the map screen, press the LEFT or RIGHT button depending on if you want to transfer the lives from Mario to Luigi or vice-versa

MEGA MAN 2

NES

Uh, oh, complaints time. **Tom Harrison-Read** from Harrow writes in to say that the previous *Mega Man 2* code I printed in issue 4 didn't work. (Whoops!) But being such a great, super, terrific chap, Tom gives us the real McCoy and a few juicy tips.

A1 B2 B4 C1 C5
D1 D3 E3 E5

To kill Dr Wily when he has mutated to the green android, you must use bubbles and dodge the bullets. When he's low, jump above him and fire.

SUPER MARIO LAND

Game Boy

Not-so-simple **Simon James** from Telford sent loads of tips (and paper-clips!). The first is for this easy Game Boy Mario extravaganza. But it's not so easy now as Simon has found a new, harder game. When you have completed the game, wait till THE END appears on the screen. Press START and Mario's head should appear instead of the mushroom. Now try to complete the game in this more difficult mode. When you get back to the title screen, you should have a level select which is operated by A or B.

CASTLEVANIA

NES

Want to know how to get past the end of level nasties? **Simon James** has the answers.

Level 1 (The Bat) – Use the axe.

Level 2 (Medusa) – The firebombs drain her energy the best.

Level 3 (Mummy Man) – Use the firebombs to kill one at a time.

Level 4 (Frankenstein & Igor) – Use axes to hit Igor then Frankie or attack Igor with the whip and while he's stunned get Frankie with the firebombs.

Level 5 (Grim Reaper) – Get rid of all his rings then attack with the boomerangs.

Level 6 (Count Dracula) – Jump over his shots and whip him in the head till he's dead. When he turns into a bat, throw firebombs at him and whip him in the head while he's stunned, but watch out for his jumps.

Also, when you get to the demon bat, smash one of the blocks in the room to find the double shot.

FAXANADU

NES

Steve also helps out on this latest game to stomp into the UK charts. Visit the being in the first town who will give you 1500 gold pieces. Go off and spend it on useful things like weapons etc then go back to the being and continue getting money.

BIONIC COMMANDO

NES

If you're hassled by a particularly annoying level, **Steven Renney** from Seghill in Northumberland reveals how to start again with full energy. Press A, B and START at the same time.

NARLY TIPS INDEX

NES

TITLE	ISSUE	CHEAT
Arkanoid	3	Continues
Bad Dudes	6	Extra lives
Batman	8	Beat Joker
Bubble Bobble	6,7	Codes
Cobra Triangle	5	Extra points
Double Dragon II	6	Extra lives
Ghosts 'n' Goblins	8	Level select
Gunsmoke	3	Machine gun
Ikaru Warriors	8	Stage select, continues
Kid Icarus	4	Extra everything, low prices
Mega Man 2	4	Passwords
Metroid	3	Woman code
POW	5	Extra lives
Rad Racer	8	Track select
RoboCop	5/8	Continues/exit level
Solar Jetman	8	Level codes
Tiger Heli	7	Continues
TMHT	8	General tips
Top Gun	4	Level select
Track & Field	6	Codes

GAME BOY

TITLE	ISSUE	CHEAT
Bugs Bunny	8	Codes
Castlevania	5	Extra life locations
Contra	8	Extra lives
Daedalian Opus	3	Passwords
Fist of the North Star	8	Codes
Fortress of Fear	7	General tips
Godzilla	8	Sound test
Golf	6	Retake shot
Hyper Lode Runner	3	Passwords
Mickey Mouse	7	Codes
Nemesis	3/7	Full weapons/bonus level
Pipe Dream	6	Codes
Super Mario Land	7/8	Secret rooms/extra lives
Tennis	7	Winning cheat
Tetris	4/5	Better scores/harder game
TMHT	3/4	Bonus games/extra energy

SUPER FAMICOM

TITLE	ISSUE	CHEAT
Final Fight	7	New options
Plotwings	7	Codes
Super Mario World	8	Exit level



GARGOYLE'S QUEST

Game Boy

Tom Bristow from Blandford sent in these super codes.

Village 1: F90X GK5N

Village 2: CK49 7PL8

Village 3: P7IL SZCN

Village 4: 8MSS EEZV

Village 5: ILAQ BJ8E

Village 6: DXNG CTWN

To defeat Rushifell and Breager wait for them to lower their arms and fire at their heads.

Ryan Jones from Atherton also sent in some codes, although he hasn't got a clue where they take you!

AT6X VFXG B2K4 7SA6

ICTN BH1X 7MR9 KBS6

FHOC WKYK ATMQ XF8V

BUBBLE BOBBLE NES

Paul Bush from Teddington has found that another player can join at any time by pressing A, B and SELECT at the same time. Or you can steal the other player's lives when you're dead by pausing the game and pressing SELECT.

GREMLINS 2 NES

Goodness me, who is this little tipster I see before me? Why, it is none other than Luke "Dumbo" Fenech from Battersea, the phantom elephant joker who's been supplying us with page bottoms for the past two issues. Sorry for spelling your name wrong in last month's masthead on the contents pages, but here's a *Rescue: The Embassy Mission* cart for your trouble. More jokes could receive similar rewards...

GBQK BVKF
DXNH CGMW
NJTD ZFPJ

PS: How does an elephant get down from a tree? Sits on a leaf and waits till autumn!

TIPS, TIPS, TIPS

Yo, fellow dudes and dudettes. If you've got a tricky tip or cheeky cheat on any NES, Game Boy or Super Famicom game, then why not send it in. You never know, you could be like Luke Fenech of Battersea, this month's winner of a free cart. Also, why not send in a picture of yourself (even drawings will do) to accompany your tips. The funniest will be printed every month. Write to Narly Nintendo, RAZE, Unit 3, 7 Back Street, Trowbridge, Wiltshire BA14 8LH. Ciao!

CONTRA NES

To get 30 lives, Andrew Beirne from Amersham says do this: on the title page, press UP, UP, DOWN, DOWN, LEFT, RIGHT, LEFT, RIGHT, B, A, B, A then START.

TEENAGE MUTANT HERO TURTLES

NES

Yo, ninja dudes. As the second Turtles movie, *Secret of Ooze*, sweeps through the cinemas in America, I can bring you a complete playing guide to the original version. Yep, thanks to Andrew Germon of Penarth in South Wales, everyone can slice and dice Shredder and still get home in time for a 12-inch ham and pineapple (hold the anchovies!).

STAGE 1

Go left past the first hole, dodging the tractor, and on into the third hole. Kill everything and go to the first animal. Now change to Donatello. Jump right over the animal and hit him from behind till he dies. Now go up, but not into the first building or hole, but into the second hole. Get pizza and repeat till you've got full energy. Go left, kill everything, and onto the first ledge. Let the frogman go by till you can down-hit him through the ledge. Kill the man with boomerangs and go left up the boxes. Continue, left along the floor, jump over the animal, land and then hit him. Repeat until he dies.

STAGE 2

Keep with Donatello. Go into the door on the bridge. Go right, up the ladder, and right till you reach the furthest ladder which you should climb. Go left, kill everything, continue left to the furthest ladder up on the ledge. Climb it and go right and kill everything and collect the pizza. Go up the ladder and walk left till you get to the furthest ladder and climb it. Now change to Michaelangelo (my favourite pizza muncher).

STAGE 3

Go right and defuse the first bomb. Continue right and defuse the second bomb. Now go left, up the gap and defuse the third bomb. Go right, dodge pizza cutter, and defuse fourth bomb. Go right to defuse the fifth bomb. Go left, up gap, dodge pink leaves and change to Raphael. Now go right



then up and right to defuse the sixth bomb. Go left, down, right, up then left to defuse and final bomb.

STAGE 4

Enter the truck, go left, then up and left. Enter building and go right till you reach a ladder which must be climbed. Now go right, then up through the gap (by jumping as high as you can and pressing FIRE). Collect the rocks and go right and give the pizza to the turtle with the lowest energy. Drop down the hole, go left and open the door. Go in the Turtle's truck and left till the end of the road. Now go down and shoot the other vehicle. Shoot the barrier with the rocket and go right to blow up the other wagon. Continue right to shoot another barrier, and go down where another truck must be blown up. Now go left up the ladder and right up the other ladder. Walk left till you meet another ladder, go up it and right up the ladder. Walk left and jump over the ledge, go down ladder, collect scrolls, down ladder, right and down ladder. Collect the man in a square and go left over the blocks. Jump over the next block, jump then go left and fall into water. Repeat this and get 60 scrolls for each turtle. Now pop back into the Ninjamobile, er, Heromobile and go left then down to shoot another wagon. Shoot the barrier and go right till you can shoot another barrier. Now shoot the wagon, go down then right and shoot the wagon. Shoot the barrier and go over the bridge, shoot next the barrier, go over the bridge. Go left, down and over the bridge.

Now go left, then up, left, up, left and shoot the barrier. Left, up, left over the bridge. Left, down, right and into the building. Left, jump onto ledge, right, down ladder, left, drop off ledge onto other ledge and all the way right till you come to the ledge with the robot on it. Kill the robot and go right up the ladder and collect the pizza. Enter the building and go right, then up ladder, go right then back up the same ladder.

STAGE 5

Enter the building and go right up the ladder. Get the pizza and go down the ladder, then right, and up the furthest ladder on the right. Go left, jump onto the ledge and up the ladder. Jump over the ledge and walk right. Stop in front of the metal object and get the pizza on the far left. Go down ladder, walk left, go down ladder, right, down then jump up. Go right then jump down and continue left through the door. Left, then up through the hole. Continue through the holes till you get to number 18.

STAGE 6

If your energy is full and your weapons up to scratch, go straight down till the screen stops moving. Go in the hole, down the ladder and walk left. Climb down the ladder, and down the next, right, down ladder, right and into the door.

STAGE 7

Walk right then down the ladder, left, down, left, down. Go right and collect pizza, go left and up ladder. Walk right and use the scroll from now on. Jump up, go left, through the door and left. Do not drop down the large or small holes. Walk right a bit more and drop down the other small hole. Go right and drop down hole. Left, over hole, down ladder and collect pizza. Go up ladder, right, down hole, left, down hole, right and dodge the laser beams. Pick up the invincibility. Go down the hole and left through the door. Right and dodge the laser beams. Go up ladder, walk left, turn turtle around and shoot with the scrolls at the man with the laser. Go left through the door and onto the ledge on the far right. Unfortunately that's where Andrew's tips ran out, so if you can get any further sent in your *Turtles* hints to the normal address.

A FINAL TIP comes from both Paul Bush and John Porterfield who reveal how to share your boomerangs around. Select boomerangs and throw a few. Now before they come back switch turtles and when the boomerangs return, the new turtle will have boomerangs too.

Atari Lynx

Where else do get a fact-packed column dedicated to the Atari Lynx and crammed with exclusive previews like *Strider II* and *Viking Child*, sizzling scoop reviews like *Block Out*, mini competitions to win fantastic Lynx memorabilia, tips and tricks for all the big Lynx games, and much, much more? No where! So stick right here and prepare to be dazzled!

STRIDER II

US Gold/Atari
● £TBA ● Lynx

Back in RAZE 3 we reviewed US Gold's *Strider II* for the Atari ST and Commodore Amiga. The good news is that a Lynx version is being developed as you read this by US Gold. Whether the game is released under US Gold's banner remains to be seen. Atari certainly want the game, so it could well appear sporting an Atari badge rather than US Gold's. But that's a minor detail.

The original *Strider* appeared around two years ago on coin-op and computer simultaneously. It was a huge success. The follow-up on the Lynx looks set to cause an equally large stir.

Jumping 100 years into the future – for that is where *Strider II* is set – you enter the far off world of Magenta. The female world leader has been kidnapped by louts and taken to a secret location. You are the one delegated to

get her back. With your athletic frame you can perform spinning jumps, sliding tackles and climb up ropes while swinging at enemy attackers. Then there's your sword and gyro gun...

There are five levels to travel through. Each becomes progressively tougher. You start your day with a quiet country stroll through the forest where you'll find a menacing menagerie of monsters and mutants. From there you enter the two towers which form part of the planet's outer defences. Level three takes you deep into underground caverns while level four finds you in the planet's generating station. The final stage takes place aboard the kidnappers' space craft.

Without doubt *Strider II* is an important and exciting release for the Lynx. Don't even ask about release or price dates. The game is claimed to be around 50% complete. Given the generally longer development times necessary for cartridge-based software, you could be seeing *Strider II* in the shops around September.



Scenes from the first forest section of *Strider II* on the Lynx. You've only just started your mission which stretches over five levels. Your aim: rescue the kidnapped leader.



VIKING CHILD

Imagitec/Atari
● £TBA ● Lynx

At long last the rush of UK Lynx developers is happening. Already telegames, Psygnosis and US Gold have demonstrated their commitment to the machine. Imagitec – responsible for the *Nightbreed* RPG, *Rat Pack* and the *Viking* trilogy – are the latest UK development house to switch on to the Lynx.

Prophecy 1 – The Viking Child is Imagitec's first stab at a Lynx game, but according to the firm's Martin Hooley "there are many other projects under way."

The story goes thus. From the barbaric Vikings comes Brian, the prophecy child. And it is in his steps that you tread. All is peace and tranquillity until one day a gale force wind blows through your pathetic town sweeping all the inhabitants but you away. While hunting through the rubble of a once proud town, you bump into Odin who informs you that his evil son, Lord Loki, was responsible for the destruction and demise of the townsfolk. But all is not lost as the people of your town have not been killed; simply imprisoned within the great halls of Valhalla.

Having been informed that it's your destiny to seek out and save your people, you pack all you need for a raping and pillaging orgy and set out on your quest.

You must travel through 16 areas of the Viking land and defeat Loki's many dark followers.

The Viking Child is a hack, slay and search platform and levels romp around a scrolling landscape. The game is due for release in the next few months and will be given the full authoritative RAZE coverage when it appears in its finished form. The 16-bit version of the game was met with great enthusiasm by reviewer Les Ellis in RAZE 2, and by all accounts the Lynx version will be equally as impressive.

Strider jumps for joy at the thought of appearing on the Atari Lynx.

DESIGNER LYNX T-SHIRTS UP FOR GRABS

Here's your chance to sport the latest in designer Lynx wear courtesy of Atari. The Lynx logo and a chap from the California Games surfing section tastefully adorn these sought after collectors' items.

To enter the competition simply match the characters printed below to the games you think they come from. The characters appear in the games

A  *Strider II*, *Block Out* and *Viking Child*. It's up to you to decide which character comes from which game. If you think character A comes from *Strider II*, write *Strider II* as your answer to question A. Continue this procedure until you've got answers for all three characters. Send your completed entry on a postcard or stuck down envelope to Atari T-Shirt Competition, RAZE, The Words Works, Unit 3, 7 Back Street, Trowbridge, Wiltshire, BA14 8LH. The first six correct entries out of the box win, although bribes will be taken into consideration. Please state T-shirt size (small or medium). All entries must be in by June 24th.

B 

C 

BLOCK OUT Atari • £29.99 • Lynx

You know the type. Looks dead easy. Is easy, in fact. But drives you absolutely insane with it's mind-bending frustrating play. *Tetris*, *Columns*, *Pipemania* and countless other games fall into this bracket.

Pick up *Block Out* and you won't put it down again – the

adjustment.

The objects can be rotated in any of the three dimensions – X, Y, and Z. When you're happy with the lie of the object you can drop it down the well where it will hopefully interface perfectly with the other objects already at the base of the well.

In *Block Out* the well is sectioned. If objects completely cover a section, all the objects in that section will disappear. Your aim is

Block Out by California Dreams is similar to *Welltris* in that you must drop irregularly shaped objects into a pit and try to fit them together. The idea is simply to fit the shapes together in the best possible way without making it impossible to fit any further blocks.

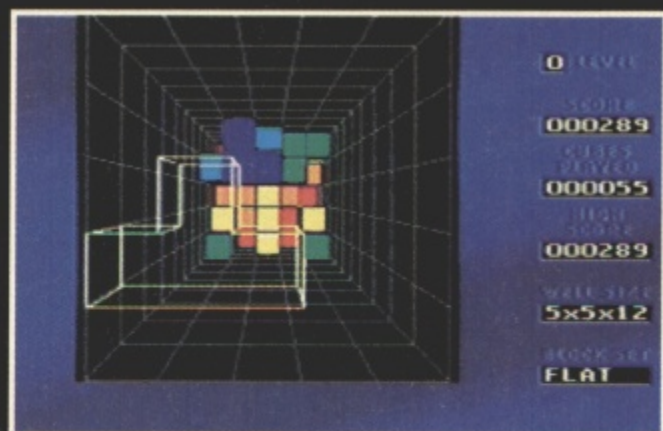

game is really that addictive.

You're faced with an overhead view of a deep well into which you must drop irregularly shaped objects. Certainly sounds easy enough. However, things are complicated by the fact that the objects don't normally fit together properly without some form of

to continue filling up sections with the shapes and try not to approach the surface of the well. Reaching the surface means game over.

Block Out is horribly playable, and is made even more addictive by being completely customisable. For instance, there are three main levels: Flat Fun, 3-D Mania, Out of Control. You can also choose the size of shapes: flat, basic and extended. Then there's rotation: fast, medium, slow. Finally, you can choose the depth of the pit from between three and 12 sections deep.

LYNX HACK SHACK

As ever the Lynx Hack Shack sack is bursting. You can fill it out further by sending your game busting solutions to Atari Attack, Unit 3, 7 Back Street, Trowbridge, Wilts, BA14 8LH. A Lynx cart to the best tip sent in.

The guest appearances by Robin Hogg and Mark Caswell in RAZE 7 caused an incredible response – none favourable:

As that Welsh dork Robin Hogg could not bring himself to tell all the readers how to do an unreal in California Games, I will inform them how...

Paul Dodd, West Midlands

I could stuff that Robin Reliant geezer on surfing any day...

Jon Fieldhouse, Kent

Oh my God! What the hell was Mark "corkhead" Caswell thinkin' when he sent in his supposed Lynx tips? If we wanna know how to play the goddamn game, we can read the flippin' instructions! We don't need some prat writin' in an tellin' us nothing that isn't already in the manual.

Aidan Hunt, Suffolk

After reading the crap Xenophobe cheats by Mark Caswell, who is obviously Corky, I think he has only got as far as the fifth space station because his cheats are about as useful as a ZX81...

Sammy McFadden, Bath

ROADBLASTERS

According to Sammy McFadden of Bath you shouldn't use a nitro immediately on collection. Instead save it until you get to the finish. Just before you reach the chequered road, hit the nitro for an interesting effect.

ELECTRO COP

In RAZE 6 we printed a solution detailing doors, how to open them and what they would reveal. On level 7, door 1, the code printed was 6012 when it should have been 6021, points out Graham Inwood of Berkshire.

XENOPHOBE

First, says Sammy McFadden of Bath, know what the numbers at the top right of the screen mean.

These are vital for completing the game and knowing where important features are. The left-most number refers to the space station, the next tells you which floor you're on while the last digit informs you of the room number you're in. The room number is the most important – there are eight rooms to each floor. You are always transported to room 1. If there is a lift it will be in room 3. If there is a self destruct it will be in one of the following:

Station	Floor	Room
3	1	4
4	4	5
6	2	5
8	5	1
10	1	4
11	4	5
13	2	5
15	5	1
17	1	4
18	4	5
20	2	5
22	5	1

Following are a few (useful) tips for getting by in *Xenophobe*:

- If there is a self-destruct unit, use it as it speeds up the game and prevents health loss.

- Pick up everything because most things have a use. Mugs, pails, vitamins and fluids give you 64 health points. The comlink gives you the percentage of infestation and a disk allows you to use the teleport system (these are the green squares in the rooms displaying infestation).

- The machines which throw bombs can be used. Stand in front of the black rectangle in the middle of the machine, press Option 2 to fix it and then press Option 1 to collect all the bombs you could ever want.

- On level 23 you'll find the Mother Fester. She won't go for you; all she'll do is move forwards and backwards quickly and lay an egg occasionally. You can only kill her by shooting the egg and then her eye.

DISCOUNT CONSOLES

TEL: 081-341 6767



★★PC ENGINE★★

PC ENGINE CORE - GRAFX PALI VERSION + JOYPAD + POWER SUPPLY UNIT	129.99
CONTROL PAD	17.99
PC-UK POWER SUPPLY	9.99
PRO 1 JOYSTICK	19.99
BATMAN	29.99
CITY HUNTER	24.99
CYBER CORE	19.99
HONEY IN THE SKY	19.99
JACKIE CHAN	34.99
OUTRUN	29.99
PACMAN	24.99
PARANOIA	19.99
PSYCHO CHASER	19.99
R-TYPE	24.99
SHINOBI	24.99
TENNIS	19.99
TIGER ROAD	19.99
VIGILANTE	19.99

★★SEGA 8-BIT★★

SEGA MASTER SYSTEM	69.99
SEGA MASTER SYSTEM PLUS	89.99
QUICKJOY 6 JETFIGHTER	12.99
QUICKSHOT 3 TURBO	9.99
QUICKSHOT JOYSTICK	12.99
QUICKSHOT MAVERICK	15.99
ALEX KIDD-SHINOBI, ARIEL ASSAULT, BATTLE OUTRUN, CALIFORNIA GAMES, CHASE H.Q., DOUBLE DRAGON, DOUBLE HAWK, FIRE + FORGET, GAUNTLET, GOLDEN AXE, IMPOSSIBLE MISSION, INDIANA JONES, ITALIA 90 MICKEY MOUSE, OPERATION WOLF, PAPERBOY, PSYCHO FOX, RC-GRAND PRIX, R-TYPE, SUPER MONACO GRAND PRIX, WONDERBOY III.	29.99
ALL ABOVE GAMES £26.99 each	35.99

GOLFMANIA	29.99
ULTIMA IV	35.99

★★ATARI LYNX★★

LYNX SYSTEM	79.99
LYNX SYSTEM PLUS	99.99
MAINS POWER SUPPLY	12.99
BLUE LIGHTING	25.99
CALIFORNIA GAMES	24.99
CHIPS CHALLENGE	24.99
ELECTROCOP	25.99
GATES OF ZENDOCON	25.99
GAUNTLET	29.99
KLAXS	29.99
MERCENARY	26.99
MS. PACMAN	26.99
SLIME WORLD	26.99

★★NEO-GEO★★

NEO-GEO SCART SYSTEM PLUS JOYSTICK + PSU	349.99
SOFTWARE FROM 124.99	

★★NINTENDO★★

ACTION SET	99.99
NES ADVANTAGE STICK	39.99
QUICKSHOT MAVERICK 2	15.99
QUICKSHOT PHYTHON 2	9.99
SPEEDKING	14.99
BAYOU BILLY	34.99
BLACK MANTA	29.99
BUBBLE BOBBLE	24.99
DOUBLE DRAGON	39.99
DOUBLE DRAGON II	34.99
DUCK TALES	39.99
FAXANADU	29.99
GHOSTBUSTERS II	34.99
MEGAMAN	34.99
MEGAMAN II	39.99
PAPERBOY	24.99
PINBOT	29.99
PROBOTECTOR	29.99
RESCUE	24.99
RYGAR	24.99
SILENT SERVICES	34.99
SIMONS QUEST	29.99
SNAKE, RATTLE AND ROLL	24.99
SOLAR JETMAN	29.99
SPY V SPY	24.99
STEALTH AST	29.99
SUPER MARIO II	39.99
SUPER OFF ROAD	24.99
TEENAGE TURTLES	34.99
TETRIS	24.99
TO THE EARTH - GUN GAME	24.99
TYSONS PUNCH OUT	29.99
WORLD WRESTLING	34.99

★★SEGA 16-BIT★★ IMPORTED VERSION

(A)
SEGA MEGADRIVE SCART OR PAL I
+ JOYPAD + POWER SUPPLY UNIT
PLUS ANY JAPANESE GAME OF UP TO VALUE
OF £29.99 134.99

(B)
SEGA MEGADRIVE PLUS 2 GAMES, CHOICE OF
ESWAT, KLAXS, CURSE, RASTAN,
GHOULS N GHOSTS, INSECTOR X 149.99

★★SEGA MEGADRIVE★★ OFFICIAL VERSION

MEGADRIVE + ANY UK GAME
UPTO £29.99 169.99
PLUS JAPANESE ADAPTOR

MEGADRIVE + ALTERED BEAST + ADAPTOR
TO RUN JAPANESE GAMES. WORTH £15
PLUS GAME OF OUR CHOICE 179.99

8-BIT CONVERTOR	29.99
NEW PRO 2 PAD + AUTOFIRE	18.99
ARCADE POWER STICK	29.99
PRO 2 PAD INC AUTOFIRE	14.99
EXTRA CONTROL PAD	12.99
POWER SUPPLY UNIT	9.99
PROFFESIONAL 1 J/STICK	24.99
QUICKSHOT SG JETFIGHTER	13.99
SCART LEAD	9.99

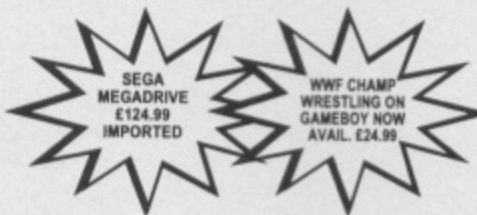

SOFTWARE	JAP SOFT	UK USA SOFT
AERO BLASTER	34.99	
ALTERED BEAST	24.99	29.99
BATTLE SQUADRON		34.99
BUDOKAN		34.99
BUSTER DOUGLAS BOXING		34.99
CRACK DOWN	34.99	34.99
CURSE	24.99	
DANGEROUS SEED	29.99	
DARIUS II	39.99	
D.J. BOY		29.99
ELEMENTER MASTER	34.99	
E-SWAT	29.99	31.50
PGA GOLF	34.99	34.99
JAMES POND		34.50
GYNORG	34.99	
GARIES	34.99	
VALIUS III	39.99	
MONSTER HUNTER	34.99	
FATMAN	29.99	
GHOULS N GHOSTS	29.99	39.99
GOLDEN AXE	29.99	31.99
HARD DRIVING	29.99	34.99
HELLFIRE	34.99	
JOE MONTANA FOOTBALL		39.99
JOHN MADDEN FOOTBALL		39.99
LAKERS Vs CELTICS		44.99
LAST BATTLE	29.99	31.50
MICKEY MOUSE	34.99	35.99
MOONWALKER	29.99	34.99
MYSTIC DEFENDER		29.99
PHANTASTY STAR II-ENGLISH	39.99	49.99
POPULOUS		34.99
RAMBO III		26.50
RASTAN SAGA II	29.99	
REVENGE OF SHINOBI		31.50
RINGSIDE ANGELS	29.99	
SHADOW DANCER	29.99	
STRIDER	34.99	39.99
SUPER HANG ON		31.50
SUPER MONACO GP		32.99
SUPER VOLLYBALL	34.99	31.99
SWORD OF SODAN		34.99
SWORD OF VERMILLION		44.99
TECHNO COP		39.99
THUNDERFORCE III	29.99	
WONDERBOY III	29.99	
WORLD CUP ITALIA 90		26.50
ZANY GOLF		29.99

★★SEGA GAME GEAR★★

SEGA GAME GEAR SYSTEM	99.99
GAME GEAR + ANY GAME	119.99
CHASE HQ	24.99
COLUMNS	24.99
G-LOC	24.99
MICKEY MOUSE	24.99
MONACO GRAND PRIX	24.99
PACMAN	24.99
PENGO	24.99
PRO BASEBALL	24.99
WONDERBOY	24.99

★★NINTENDO FAMICOM★★

FAMICOM - SCART + 2 GAMES	299.99
FAMICOM PAL I + 2 GAMES	324.99
AKUTORISA	44.99
BIG RUN	44.99
BOMBUZAL	44.99
DARIUS PLUS	44.99
F-ZERO	44.99
FINAL FIGHT	44.99
GHOULS + GHOSTS	49.99
GRADIUS III	44.99
PILOTWING	44.99
POPULOUS	44.99
SUPER MARIO BROS 4	44.99
SUPER R-TYPE	44.99
ULTRA MAN	44.99

★★PC ENGINE PORTABLE★★

PC ENGINE GT PORTABLE + GAME	279.99
------------------------------	--------

★★NINENDO GAMEBOY★★

GAMEBOY DELUXE SYSTEM	69.99
GAMEBOY SYSTEM + ANY GAME	89.99
NB CARRYING CASE	12.99
TOTE CARRY CASE	14.99
DOCS CARRY CASE	14.99
LIGHTBOY - (INC WIDE BOY)	19.99
MAGNIFIER	7.99
GAME LIGHT	9.99
ILLUMINATOR	14.99
AMPLIFIER	12.99
POWER SUPPLY AC/DC	12.99

TENNIS, WIZARD + WARRIOR, REVENGE OF
GATOR, GOLF, BALLON BOY, MARIO BROS.,
SPIDERMAN, ALLEYWAY, SOLAR STRIKER
ALL ABOVE GAMES £19.99 each

BATMAN, PENGUIN WARS, BUGS BUNNY,
CASTLEVANIA, CHASE HQ, NINJA BOY,
COSMOTANK, DOUBLE DRAGON, GARGOYLES
QUEST, GHOSTBUSTERS II, HYPER LOAD
RUNNER, NFL FOOTBALL, PAPERBOY,
QUARTH, ROBOCOP, IN YOUR FACE, TEENAGE
TURTLES, CATTRAP, R-TYPE, BUBBLE
BOBBLE, DRAGONS LAIR, NEMESIS, DUCK
TALES, WWF WRESTLING, HAL WRESTLING,
BASEBALL, BOOMERS ADVENTURE, BOXXLE,
BUBBLE GHOST, BURAI FIGHTER, DEAD HEAT
SCRAMBLE, DANDELION OPUS, DR. MARIO,
F1-RACER, GREMLINS II, GODZILLA, HAIENKY
ALIEN, LOCK N CHASE, MERCENARY FORCE,
NEMISES, MOTORCROSS MANIACS,
OPERATION CONTRA, POWER RACER, PIPE
DREAM, R-TYPE, KUNG FU MASTER, SKATE OR
DIE, CHESSMASTER

ALL ABOVE GAMES
HAVE ENGLISH INSTRUCTIONS
ONE FOR £24.99
ANY TWO FOR £45.00
ANY THREE FOR £65.00

★★SPECIAL OFFER★★

TURTLES FOR GAMEBOY, JAPANESE VERSION NOW ONLY	
TEENAGE TURTLES	19.99
CONTRA - NEW RELEASE	24.99
R-TYPE	24.99

RUN JAPANESE GAMES ON YOUR
OFFICIAL SEGA MEGADRIVE
WITH OUR SPECIAL ADAPTOR
ONLY 14.99

CHQ/P.O PAYABLE TO: DISCOUNT CONSOLES (DEPT FR), P.O.BOX 1506, LONDON N8 0PZ.
TELEPHONE:- 081-341-6767. P+P ADD 75p PER SPFTWARE, £1 FOR ACCESSORIES, £5 FOR MACHINES.
ALL PRODUCTS ARE SUBJECT TO AVAILABILITY AND PRICES CHANGES,. E.& O.E.

Preview INDEX

Consoles

ATARI LYNX	Block Out	21
GAME BOY	Balloon Kid	34
	Double Dragon	34
	HAL Wrestling	58
	Power Mission	60
	Rolan's Curse	60
	PC Frog	67
MASTER SYSTEM	Heavy Weight Champ	54
	Joe Montana's Football	40
	World Class Leaderboard	56
MEGA DRIVE	Phantasy Soldier III	58
	Shadow Dancer	38
	Verytex	58
NES	Gremlins II	28
PC ENGINE	SCI	62

16-Bit

AMIGA	Atomino	30
	Disc	48
	Jet Fighter II	50
	Quadrel	44
	Shadow Dancer	38
	Switchblade II	46
	Viz	32
ATARI ST	Atomino	30
	Disc	48
	Quadrel	44
	Shadow Dancer	38
	Switchblade II	46
	Viz	32
IBM PC	Jet Fighter II	50
	Joe Montana's Football	40
	Life & Death II	24
	Spot	42



GREMLINS II © WARNER BROS. 1990

ALL THE BEST THINGS COME IN TWOS

LIFE & DEATH II25

Use brain or brawn, sinew or synapse, luck or judgement as you tear into muscle and rip apart bone.

GREMLINS II28

We warned you that feeding Julian Boardman after dark would empty your larder...

SWITCHBLADE II46

Big city sticks and small country stones might not break your bones, but a knife in your spleen will leave you head over heels.

JET FIGHTER II50

Fly into the future as you take to the skies in an F-23 and attempt to recapture California from the communists.

LIFE & DEATH II

THE BRAIN

Mad Doctor Ellis becomes a brain surgeon; let the massacre begin

MACHINE MANIA

CAT scan – Because it uses iodine, it can't be used on patients allergic to fish. Will show up many problems.

MRI scan – Can't be used for patients with pacemakers owing to the strong magnetic field put out.

X-ray – Not much use to anyone, but will show up fractures in the skull.

Angiogram – A method of x-raying the blood vessels by injecting them with a suitable substance.

The original *Life & Death* created a somewhat cult following. After all, it wasn't everyday that you could diagnose indigestion and continue to remove that person's appendix as a cure. But *Life & Death* was missing that certain *je ne sais quois*. Although the patients often screamed and squirmed beneath your deadly scalpel, you never really felt you were inflicting the greatest pain possible. But with the sequel, all that is about to change. For in *Life & Death II* you get to operate on the most complex of all the human

Your place of work, the Neurosurgery Wing of Toolworks General. The receptionist's name is Edith MacDonald, and she's situated right in the middle. If you get lost, she will help you out. The classroom is situated at the bottom left-hand corner. This should be your first port of call as there you will learn all there is to know about brain surgery.

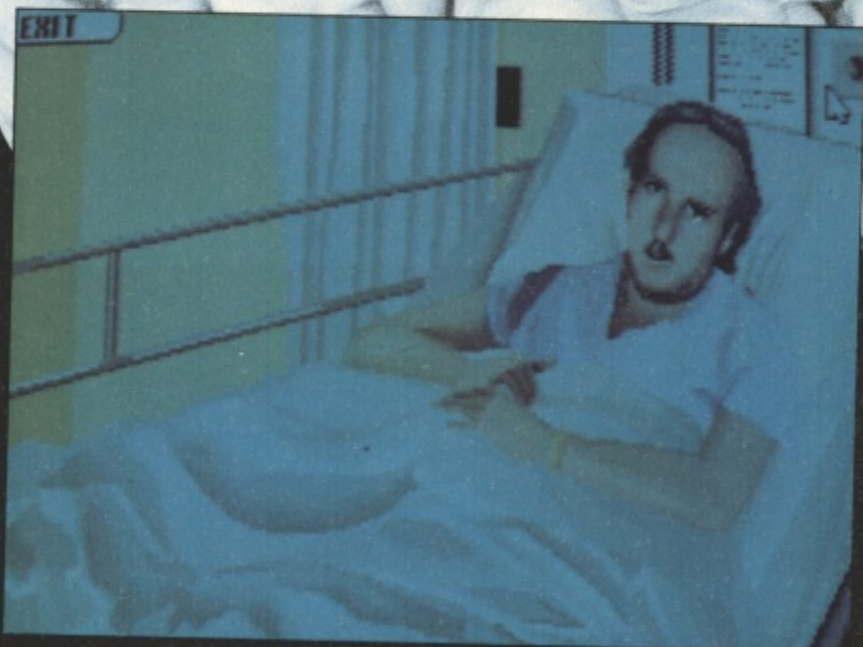
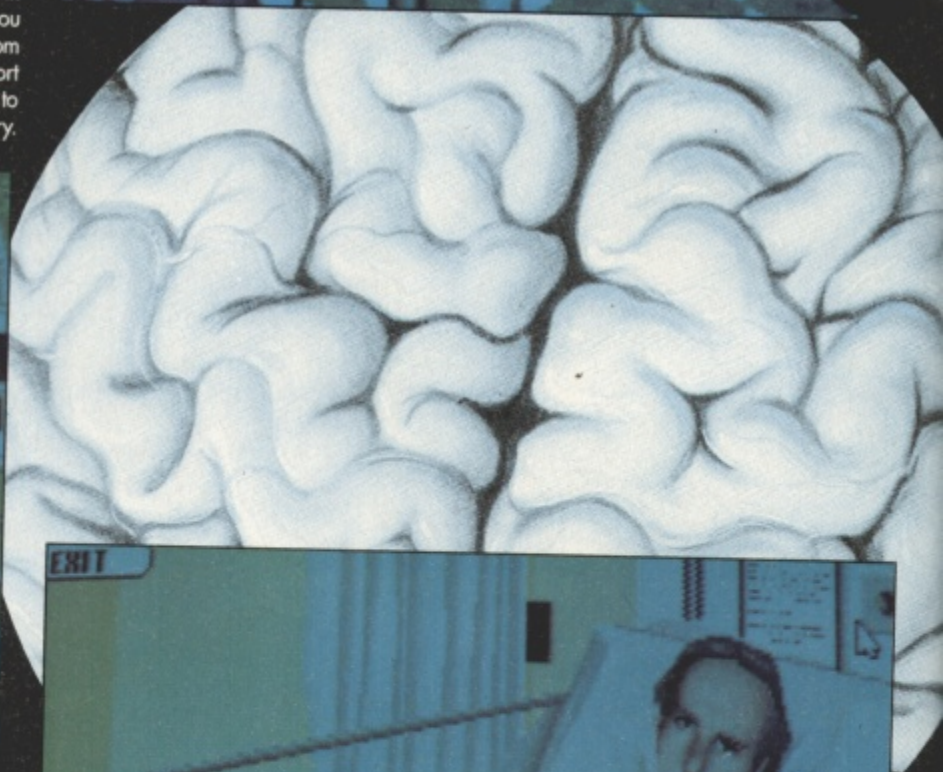
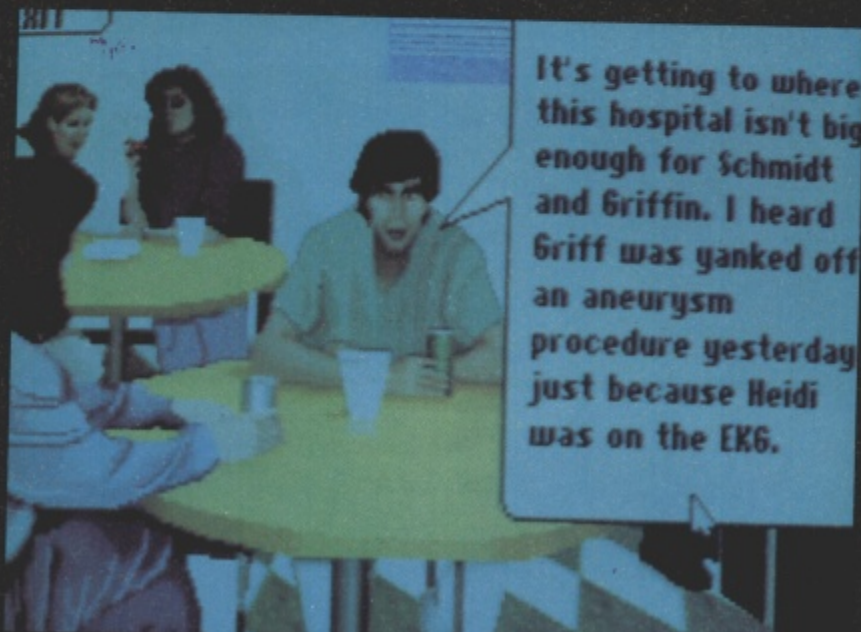

organs: the brain. After receiving a memo of welcome from Dr Ryan Skelton, Chief of Neurosurgery, you sign in at Toolworks General Hospital. Before you get down to

Pick up the latest bits of gossip at the staff canteen. (You can also watch that prat at the coffee machine have a nasty accident with your coffee.) Keep your ears open, as your colleagues will always have something to say about your progress.

the real blood and guts of the game, you would be wise to attend the classroom lessons on surgery techniques. Later on in the game, it would be prudent to return there for advice and guidance on more awkward operations (like opening up someone's skull).

After learning the rudiments of neurosurgery, you are let loose on live patients. Your first task is to examine them and diagnose their ailments. To do this, you must first carry out a physical examination of your patient, looking at their head, arms and legs to discover any symptoms that may help in your diagnosis. From then on, you

If all else fails, you can always return to Edith MacDonald and find out exactly where you're supposed to be. In fact this nosey old cow knows just about everything there is to know; I don't know why they didn't make her the chief neurosurgeon.

first.

Now you've got all your information at hand, you must decide what action to take. The wrong treatment has catastrophic results and trial and error is an unwise approach to take. Just because the game is based around brain operations, it doesn't mean that every patient must be trolleyed into the operating theatre. Some patients will not react too favourably to a lobotomy when all they needed was a bit of physiotherapy.

Not only a steady hand and a keen eye are needed to become one of the hospital's best first-year neurosurgeons. You'll also need to

have a sound knowledge of your subject, and be able to diagnose all your patients successfully. The more ops you carry out without glitches, the more certificates you'll see appearing on your office wall.

Of course, if you're not quite up to the calibre of surgeon required for such a demanding job, you could always try out for that vacancy down at the morgue.

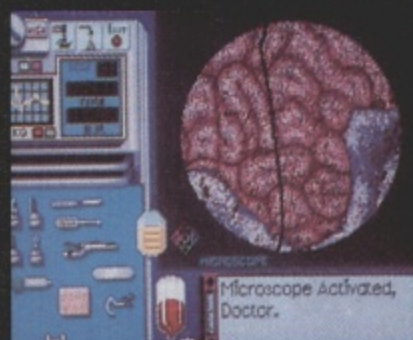

DOCTOR, DOCTOR...

- ★ I haven't got the patience to be a doctor.
- ★ Knock, knock. Who's there? Sarah. Sarah who? Sarah a doctor in the house?
- ★ Why are dentists always sad? Because they're always looking down in the mouth.
- ★ Doctor, doctor, I feel like a pack of cards. Don't worry, I'll deal with you in a moment
- ★ Doctor, doctor, I've got a sore leg. Well go to the window and stick your tongue out. Will that help? No, I just don't like the neighbours.
- ★ Anyone who goes to a psychiatrist needs their head examining.

must choose which path to go down, and whether to carry out a CAT scan, x-ray, etc. Failure to spot any internal damage can often result in a very messy outcome. However, some people have quite nasty reactions to these tests so make sure you read the medical history of the patient



"Aha! The ol' pacemaker in the MRI machine trick! Bet the Doc doesn't try that one again!"

The CAT scan is just one of the tests you can carry out to try and discover what is wrong with the patient. But remember, if they are allergic to fish, the CAT scan will kill them - snigger, snigger...

GRAPHICS 89%
 ✓ An excellent "hands-on" feeling for ops.
 ✓ Absolutely gross in some operations.

SOUND 88%
 ✓ Digitised voices and screams.
 ✓ Supports AdLib and SoundBlaster.

PLAYABILITY 84%
 ✗ The examinations become repetitive.
 ✓ Immense depth, will last for months.

IBM PC

THE SOFTWARE TOOLWORKS
 £30.64 • OUT NOW **87%**

The ST is just

The Atari ST is the perfect introduction to the world of computing. The power of the ST allows you to run "serious" applications as well as playing games, and the ST system is flexible enough to allow you to expand as you develop your interests and expertise in different applications.

With so much diversity and power it is easy to see why the Atari ST family is one of the most successful ranges of computers in the world. But best of all is the built-in growth potential. The 520ST user of today is the TT user of tomorrow; beginning with games or a simple word processor, anyone can learn about computers and gradually acquire the skills of the professional computer user. And unlike many other systems, an Atari upgrade is not wasteful. Much of the software available for the 520ST will run on both the Mega STe and the TT systems. With an Atari an upgrade means that you can add new capabilities and expand your computing horizons without losing everything you have acquired along the way.

*If you thought that computers were all about playing games you've been missing out on the real potential that you and your computer have. To find out more about either the **Atari ST** or peripherals for any applications simply fill in the coupon and send it to Atari at the address below.*



*Whether you are looking for a leisure computer, an educational computer, a computer for all the family or a powerful business system, look no further than the **Atari ST Range**.*

Please send me more details about the Atari ST and other products

NAME _____

ADDRESS _____

POSTCODE _____

Atari Corp UK Ltd, Atari House, Railway Terrace, Slough SL2 5BZ



The Atari 520ST is an easy way for you and your family to learn about computers while having a great deal of fun. This best-selling computer has an impressive range of features that fit many requirements at home or in the office. A generous 512K RAM memory is included as standard - enough to run large spreadsheets and databases as well as the latest generation of computer games. There are plenty of expansion ports available for printers, modems, monitors and hard disk, and other peripherals allowing you to increase the power and flexibility of your system as needed. MIDI expansion ports are fitted as standard. MIDI (Musical Instrument Digital Interface) is the music industry standard interface that allows you to control both recording and playback of synthesisers and other digital instruments with your computer.

There is no other computer range in the UK that can offer its users such a wide variety of software support, ranging from educational learning programs to 16-bit computer games to professional quality desktop publishing packages.

The ATARI ST

the beginning



The power of the new **Mega STe** range makes it a serious contender for those who are after power computing. It is an ideal machine for the student or computer enthusiast who wants to run memory intensive applications such as Computer Aided Design (CAD) or graphics applications. The Mega STe features separate keyboard and central processor with a 1MB floppy disk drive and a 50MB Hard Drive for data storage. The Mega STe features a fast 16MHz operating speed, which can be switched to 8MHz to run any programs developed for the 520ST, making it even easier for you to upgrade.

For those of you who want to run a 'home office' with separate files for word processing, spreadsheets and accounts packages the Mega STe - with its vast amount of built-in hard disk storage - is an excellent choice. For those running graphics intensive programs the faster operating speed will make the Mega STe a much more productive machine. The Mega STe also features an extensive range of expansion ports that allow you to add even more power and flexibility to your system.

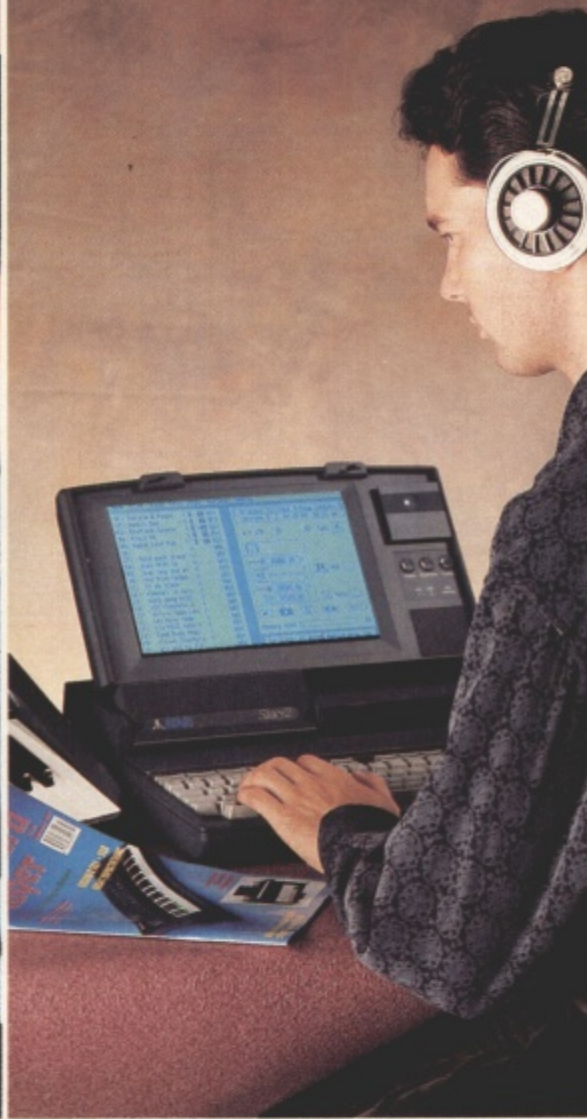

The portable **Atari Stacy** is completely compatible with all monochrome ST programs, but allows for complete portability. It features a supertwist backlit LCD mono screen, split horizontally and has all the standard ST ports. It is available in various configurations, with Hard disk as standard. It weighs approximately 15.2 pounds and has its own carrying handle making it easy to transfer from place to place. Because the ST, with its MIDI interface has become the accepted standard in the music industry, the Stacy is a boon machine for musicians with a busy schedule. Songs and sequences written at home can be stored on the built-in hard disk, then the whole computer can be easily transported to the studio or gig, with minimum stress, they can even be worked upon and improved on the road. Although it is the most specialist member of the ST family, the Stacy is still versatile enough to be used for all serious ST applications.

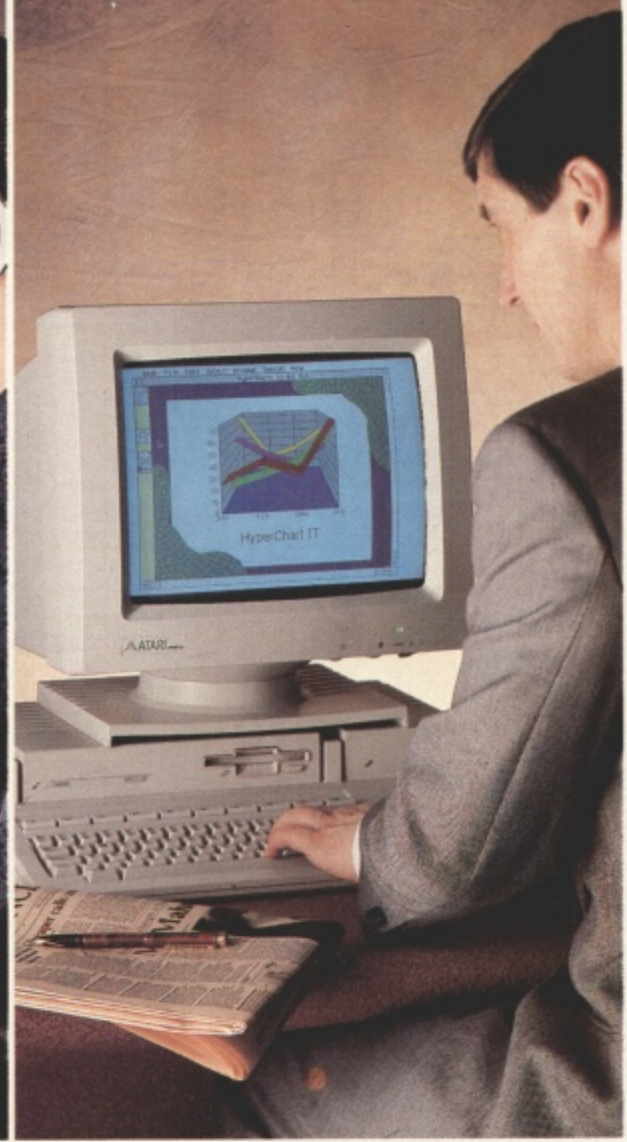

The incredibly powerful **Atari TT**, at the very top of the Atari range, is the first in a new generation of high specification professional personal workstations based on the successful Atari ST standard. Similar in style and design to the Mega STe, the Atari TT features a separate keyboard, 1MB floppy disk, 50 MB Hard Drive and the same range of excellent expansion ports. The basic model comes configured with 2MB RAM which can be expanded up to a massive 26MB. With a Motorola 68030 central processor, the TT runs at up to 32MHz. But speed and power are not all the TT system offers the professional user. Six standard built-in screen resolution modes mean that there is always one suitable for the purpose that you have in mind. For animation or computer graphics, choose from a palette of over 4,000 colours with the ability to display 256 on screen at any one time, and the exceptional 1280 x 960 pixel high resolution mode is one of the best screen modes available at any price.

— More than just great games



GREMLINS 2

THE NEW BATCH

Don't expose him to bright light, don't get him wet and never feed him after midnight... But we broke all the rules and let Les Ellis loose

If you thought the damage they inflicted on Kingston Falls was bad, wait till you see what hundreds of Gremlins running loose in a NYC tower block does. Yes, those cute little furballs of terror are back on our screens, wreaking havoc like nothing on Earth.

You'd have thought that the world would have been saved of the terrors since Mr Wing took Gizmo back from his irresponsible kidnapers in the first movie. But the old man didn't last too long in New York, and has now died, leav-

ing his premises to be taken over by Daniel Clamp and his multimillion dollar empire. Where Mr Wing's old shop once stood is now the monstrous Clamp Centre, fully automated and home to hundreds of Clamp businesses. By pure coincidence, Billy and his girlfriend Kate have also

moved to the big city and are currently in Mr Clamp's employ as a commercial artist and Clamp Centre tour guide respectively. While working in the Centre one day, Billy hears a mail clerk whistling one of Gizmo's little tunes. Anyway, to cut a long story short, Gizmo was found in the rubble of Mr Wing's shop by Clamp geneticists who are now experimenting on him. Billy rescues Gizmo from the genetics lab in Clamp Centre and takes him back to his own desk. But, wouldn't you know it, Gizmo gets hit by a freak leak in a drinking fountain and the evil Gremlins are hatched. Which is where we pick up the story. Unlike the Elite computer conversions of the film, the

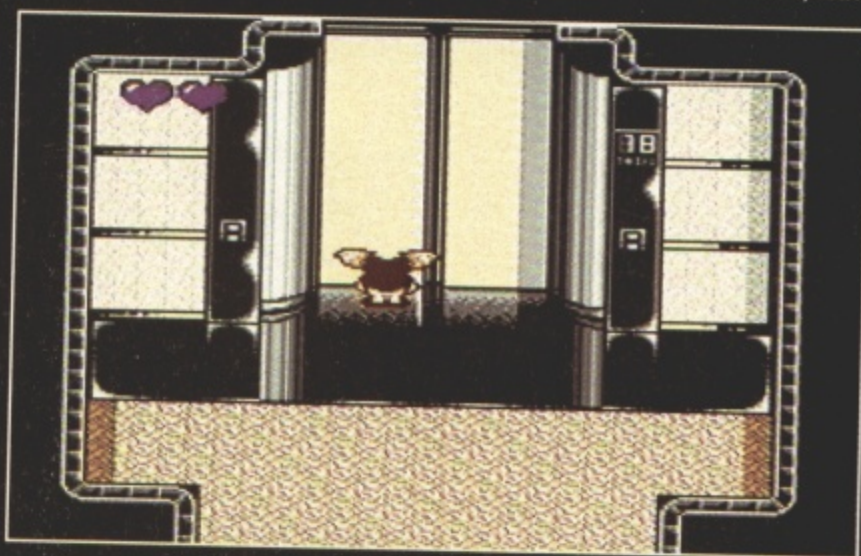

ing his premises to be taken over by Daniel Clamp and his multimillion dollar empire.

Where Mr Wing's old shop once stood is now the monstrous Clamp Centre, fully automated and home to hundreds of Clamp businesses. By pure coincidence, Billy and his girlfriend Kate have also

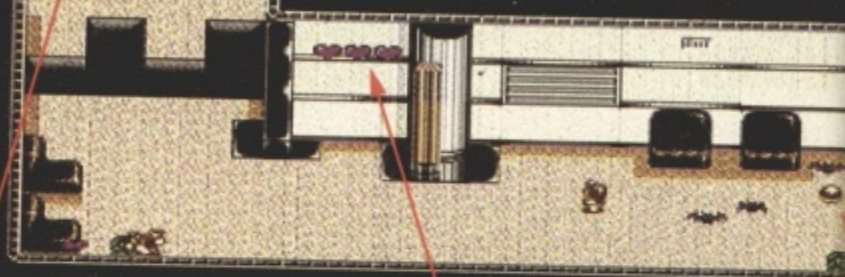
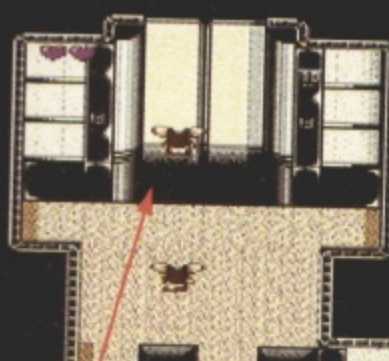

GIZMO'S GADGETS

- Tomato – basic weapon, can't be powered up.
- Match – can be powered up to fire in three directions.
- Paper Clip – can be powered up to throw in three directions.
- Bow and Arrow – when powered up, shoots five projectiles.
- Bow and Fire-Headed Arrow – best weapon available.
- Crystal Balls – used as money to buy things from Wing's shop.
- Flashbulb – when touched, will destroy all enemies onscreen.
- Pogo Stick – used to jump on the enemies to kill them.
- Time Stopper – temporarily freezes all the enemies.
- Balloon – helps Gizmo go over a hole in the ground.
- Life – recovers your life.
- Power Pak – powers up your weapon.
- Gizmo Clone – extra life.
- Heart – steps up the number of hearts onscreen.

● A hop, skip and jump and you're home safely. Well, you've completed the first section of the first level. The first level has two stages as do the other four levels. The exit leads to a lift which shunts you to the next stage. All the levels apart from the first feature a large end-of-level guardian. In level two you'll find Mohawk, in level three there's the Electric Gremlin to contend with while levels four and five feature a much-mutated Mohawk. But then, you'll never get that far...

● A number of hearts are shown in the upper left of the screen during play. You get a meagre three hearts at the start of your game playing session. The maximum number of hearts possible onscreen at any time is four. Gizmo is subject to one damage point when hit by an enemy, falling down a hole or bumping into a barrier. Two damage points result in one heart being lost. When all hearts are gone from the screen, Gizmo has well and truly snuffed it. In fact, he's kicked the bucket, deceased, has been, is no more, popped off, gone to meet his maker, history, passed on, left the land of the living...

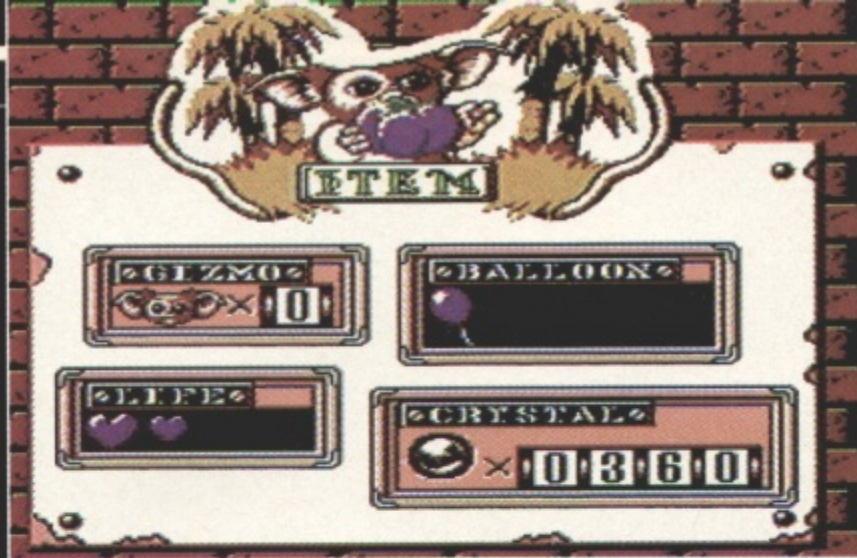

NES version is based around the more adventurous exploits of Gizmo and not "boring" Billy. We first meet Gizmo on his way to Billy's office. From here he gets thrown into the air duct system, where Giz discovers that the Gremlins have spread throughout the whole of the building. After climbing out of the duct, our furry friend finds Clamp TV station, and tries to make his way to Daniel



Clamp's office. On his way, Gizmo bumps into a whole array of weird and no-so-wonderful mutated Gremlins in the genetics lab. Finally our hero reaches his main goal, the Clamp Centre Control Room, where he wages his final battle with Mohawk in spider form.

Along the way, Gizmo can pick up extra weapons (see Gizmo's Gadgets). He can also pop into Mr Wing's shop, which miraculously appears at certain points throughout the Clamp Centre, and purchase special items.

If Gizmo fails in his personal quest against the Gremlins, the whole lot of them will be let loose upon New York. And what a disaster that would be.

GRAPHICS 78%

✗ Backgrounds are empty and colourless.
✓ Super static storytelling scenes.

SOUND 80%

✓ Boppy title tune plays throughout game.
✓ Bright effects on pick-ups and killing.

PLAYABILITY 85%

✓ Very playable with five large levels.
✓ Password system ensures challenge.

NES SUNSOFT £39.95 • OUT NOW **82%**

ATARI ST £24.99 • REVIEW #3 **ELITE**

AMIGA £24.99 • REVIEW #3 **ELITE**



• Oi, Gizmo, stop trying to sneak a quick slash behind that chair. There simply isn't time for that sort of thing. Instead, take time out to visit Mr Wing's Magic shop. You can buy all sorts of useful gadgets in exchange for the crystals collected on your quest. A balloon will transport you over chasms, a life jar will get you back to full health, a power pack will power up the weapon in your possession, a Gizmo clone will add an additional life and a heart will increase the total number of hearts making up your health bar.

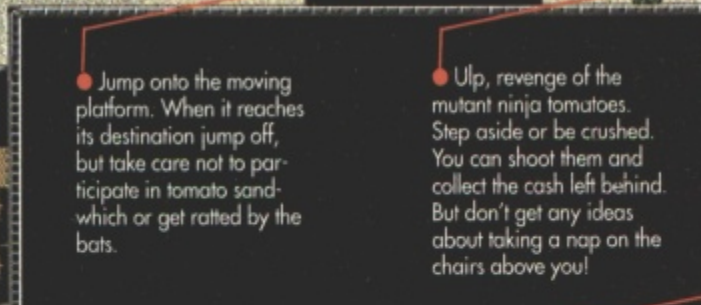
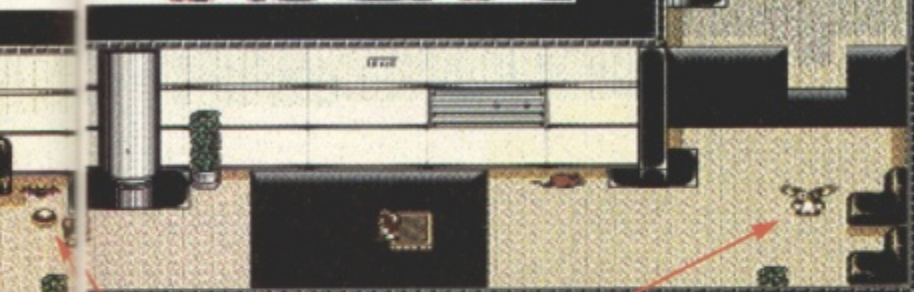

• Jump onto the moving platform. When it reaches its destination jump off, but take care not to participate in tomato sandwich or get ratted by the bats.

• Ulp, revenge of the mutant ninja tomatoes. Step aside or be crushed. You can shoot them and collect the cash left behind. But don't get any ideas about taking a nap on the chairs above you!

• You can either jump this combination or go around it. Watch out for the rat; shooting it gives you money.

• When an enemy is beaten, an item will be left behind. A crystal ball (like the one shown here) can be exchanged for various items at Mr Wing's shop, a flash-bulb will destroy all enemies onscreen smart bomb-style, a pogo-stick enables Gizmo to leap on all enemies for a short period, and the time stopper halts all enemies for a short while.

• At the end of each level a power up item appears (except for the tomato which is available at the beginning of the first level). At the end of the first level you'll find a match which shoots out flames. The second level provides you with a paper clip which can be thrown at the enemy. With a rubber band and pencil encountered in level three, Gizmo can assemble a bow and arrow by using the paper clip from the previous level. Finally, in the fourth level, you can use the bow and arrow to shoot explosive pigs.



Bright spark, Les Ellis gets positively charged over this microscopic puzzler

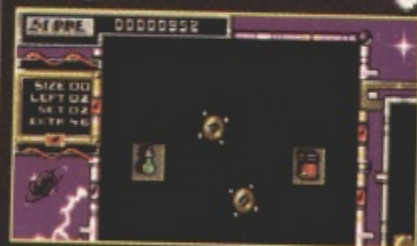

On some of the levels, the molecules are already on the screen and you have to remove them by building up the links.

It's a sign of the times we live in that the sole act which changed the way we live more than any other should have a computer game written about it. When Al Einstein split the atom in the early 20th century, who would have thought that a Liverpoolian comput-

could this be the start of a whole new genre?

Psygnosis' attempt at a puzzlecum-educational game is based around the simplest of ideas. All you have to do is join an atom to other atoms to form a solid grid without any loose links between the atoms. Okay, so it doesn't sound that easy, but the premise is pretty simple. Unfortunately, there are a couple of barriers that have to be overcome before you solve the grid. Your main enemy is the space in which you work, it is limited to just a few atoms across and down and is very restricting. Time is also

spinning around them. As you progress through the levels, the less time you will have and obstacles will start to appear onscreen. The obstacles take the form of decorative icons which stand for nothing but awkwardly obstruct the logical route.

Atomino is a game you really have to sit down and play; it's not the sort that looks enthralling from over someone's shoulder. The challenge of the strategic elements is set about right, although the game can get so infuriating that you give up in despair. A strange release from Psygnosis.

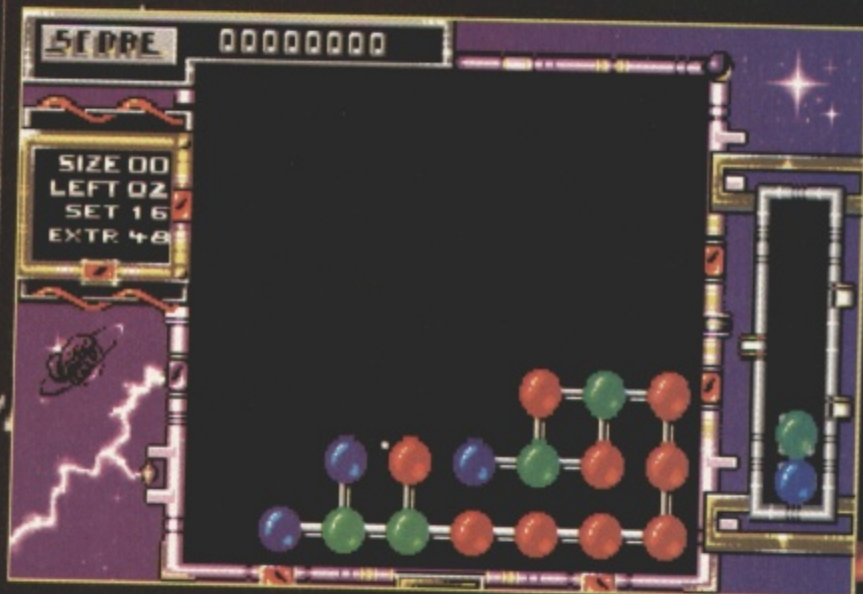

Level one is fairly easy - and is about to be completed in a very complex manner. The pit on the right-hand side holds only six pieces and shows what atoms are available to be used on the grid.

er software house named Psygnosis would want you to get all those atoms together again? Certainly not old Albert himself, I would venture to say. Indeed, atoms also featured heavily in Thalion's *Atomix* late last year, so

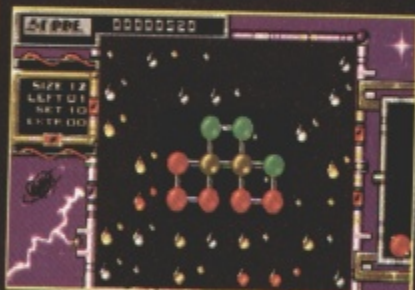
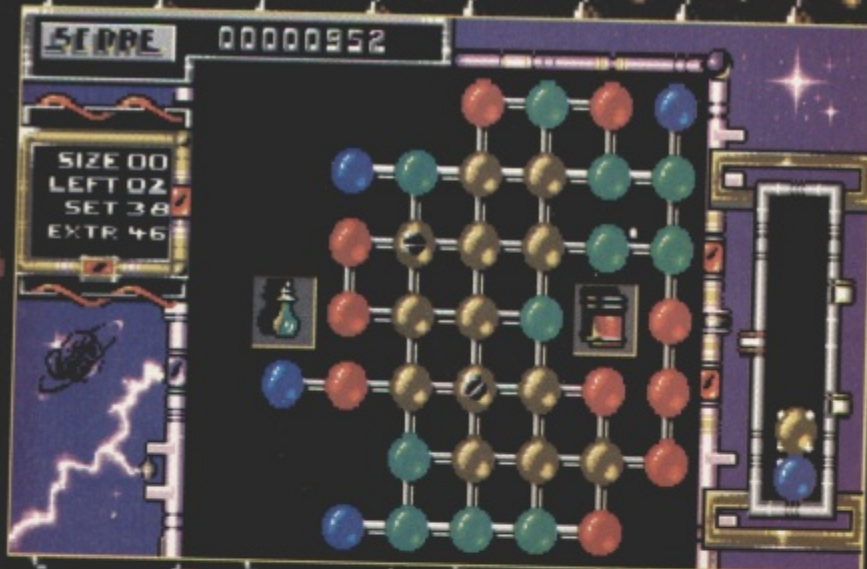

IT'S A LINKS GAME

- Stopper - has only one link and is useful for ending paths.
- Two-way - useful for creating and connecting corners.
- Three-way - can be used to divert a straight line.
- Four-way - Murphy's law dictates that this piece normally turns up when you don't need it.

not on your side; it quietly ticks down in the corner but can soon bring Game Over if you're not quick in your construction.

Before the atoms have to be placed on the grid, they fall into a pit on the right-hand side of the screen. The pit holds up to six atoms, each one with its own little connector(s) spinning around it. The atoms must be judiciously placed so that they link as many of their connectors with loose connectors on the atoms already placed on the screen. Get the idea?

A level is completed when all the atoms on the screen are bonded together with no loose connectors

IBM PC PSYGNOSIS £34.99 ● OUT NOW

ATARI ST PSYGNOSIS £25.99 ● OUT NOW

GRAPHICS 76%
 x No backgrounds to add variation.
 ✓ Clear atoms with good shading.

SOUND 71%
 x Wimpy spot effects add little to game.
 ✓ Atmospheric music sets heart pounding.

PLAYABILITY 79%
 x Soon becomes boring or infuriating.
 ✓ Initially quite a challenge, though.

AMIGA

PSYGNOSIS £25.99 ● OUT NOW 77%

SPECTACULAR SEGA SAVERS

SEGA MEGA DRIVE

Sega Mega Drive which is compatible with all UK, American and Japanese software (worth £189.99).

SCART £125

PAL £145

Alex Kidd in Enchanted Castle.....	27.50	Phantasy Star II.....	54.99
Arnold Palmer Tournament Golf.....	32.50	Populous.....	37.50
Budokan.....	37.50	Rambo III.....	23.99
Columns.....	27.50	Revenge of Shinobi.....	32.50
Cyberball.....	32.50	Space Harrier II.....	32.50
ESWAT.....	32.50	Strider.....	41.99
Forgotten Worlds.....	32.50	Super Hang On.....	32.50
Gain Ground.....	32.50	Super League Baseball.....	32.50
Ghostbusters.....	32.50	Super Monaco GP.....	32.50
Ghouls 'n' Ghosts.....	42.50	Super Real Basketball.....	32.50
Golden Axe.....	32.50	Super Thunderblade.....	32.50
Herzog Zwei.....	32.50	Sword of Vermillion.....	45.99
James Pond.....	37.50	Thunderforce II.....	32.50
Last Battle.....	32.50	Truxton.....	32.50
Mickey Mouse.....	37.50	Twin Hawk.....	32.50
Moonwalker.....	32.50	World Cup Italia 90.....	27.50
Mystic Defender.....	32.50	Zany Golf.....	37.50

SEGA MASTER SYSTEM

Only £54.99

MASTER SYSTEM PLUS

Only £74.99

Aerial Assault.....	27.50	Paperboy.....	27.50
Action Fighter.....	11.50	Psycho Fox.....	27.50
Afterburner.....	27.50	R-Type.....	27.50
Alex Kidd.....	22.50	Rambo III.....	27.50
Alex Kidd - High Tech.....	27.50	Rampage.....	27.50
Alex Kidd - Lost Stars.....	27.50	Shinobi.....	27.50
Alex Kidd - Shinobi.....	27.50	Space Harrier 3D.....	27.50
Altered Beast.....	27.50	Spellicaster.....	27.50
American Pro Football.....	27.50	Spy v Spy.....	16.50
Columns.....	22.50	Super Monaco GP.....	27.50
ESWAT.....	27.50	Ultima 4.....	37.50
Fantasy Zone 2.....	22.50	Vigilante.....	27.50
Gauntlet.....	27.50	Wonderboy.....	22.50
Golden Axe.....	27.50	Wonderboy in Monsterland.....	27.50
Golfmania.....	31.50	Wonderboy III.....	27.50
Golvellius.....	27.50	World Soccer.....	22.50
Impossible Mission.....	27.50	Zillion.....	22.50
Miracle Warrior.....	31.50	Zillion II.....	22.50

All the above Master System and Mega Drive games are official UK versions.

All prices include VAT & P&P

Telephone us with your order on 0225 765086 or fax us on 0225 777869
Or post form to: Mail Order, The Words Works Ltd, FREEPOST
(SN 1543), TROWBRIDGE, Wiltshire BA14 8YA

I would like to order _____
and enclose a cheque/PO (made payable to The Words Works Ltd) for _____
Or charge my Access/Visa number _____
Expiry date _____ Signature _____
Name _____
Address _____
Postcode _____ Tel. No _____

THE UNOFFICIAL GUIDE TO BEATING SEGA MASTER SYSTEM AND SEGA MEGA DRIVE GAMES

Complete SEGA SOLUTION

The Complete Sega Solution is a comprehensive collection of tricks, tactics and playing solutions for over 120 top Sega Master System and Sega Mega Drive games. But it's more than that; every game is reviewed and rated so you can decide at an instant whether a game is worth adding to your collection.

The Complete Sega Solution is the most accurate and fact-packed guide to winning Sega games. In over 200 pages you'll discover secrets buried deep within games; infinite lives, hidden messages, level selects, bonus rounds, concealed stages, unlimited continues, programmer access codes, even games within games.

The Complete Sega Solution features essential playing guides for many of the biggest games. These take you step by step through levels, inform you how to get past obstacles, where to pick up special items, and how to deal with attackers. In short, the playing guides will get you from start to finish.

The Complete Sega Solution contains more than 120 top games, including Alex Kidd, Arnold Palmer, ESWAT, Gain Ground, Ghostbusters, Ghouls 'n' Ghosts, Golden Axe, James Pond, Mickey Mouse, New Zealand Story, Rainbow Islands, Revenge of Shinobi, Ringside Angel, Shadow Dancer, Strider, Tetris, Wonderboy III...

AVAILABLE FROM ALL GOOD BOOKSHOPS NOW



OR ORDER BY POST OR PHONE
DIRECT FROM THE PUBLISHER

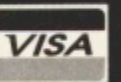

Post this form to: Sega Solution, The Words Works Ltd, Freeport (SN 1543),
Trowbridge, Wiltshire BA14 8YA. Telephone: 0225 765086 Fax: 0225 777869
Please make cheques payable to The Words Works Ltd.

I would like to order a copy of *The Complete Sega Solution* priced at £9.99 and enclose
a cheque or postal order for _____
Charge my Access/Visa number _____
Expiry date _____ Signature _____
Name _____
Address _____
Postcode _____ Telephone Number _____

VIZ

THE COMPUTER GAME.

King of the Crap Jokes, Les Ellis, bumps into a few close friends

Not only was Viz the funniest of the glut of comics to appear in the early Eighties (well, okay, 1979), it was also the most controversial. Featuring such characters as Johnny Fart-pants, Sid the Sexist and Roger Mellie (the man on the telly), it soon doubled, tripled, quadrupled, etc its



Between races you get a top tip, which makes interesting reading while the next level loads and decompresses.

original circulation of 150 to become one of the best selling magazines in Britain. Indeed, the UK circulation of Viz today is regularly over one million, with only three other periodicals topping its figures. But even with



CHOOSE YOUR PLAYER



want to be associated with Biffa Bacon? – I think not. So in stepped Virgin to save the day and keep the Viz characters alive. And along with Virgin came street cred, and, more importantly, advertising (including Sega's). But, of course, everything has a price and in this case it was college trendy types using the mag as another wardrobe accessory.



In the pancake flattening bonus stage, Buster Gonad must use his incomprehensibly large testicles to squash pieces of dough produced by the pancake machine. Make sure the pancake is completely flat or it doesn't entitle you to a bonus.

Having chosen Johnny Fartpants (there's always a commotion going on in his underwear), you enter the first bonus stage. The higher you get, the more bonus speed-up tokens you receive.



Mellie spouts off in his normal fashion. The language may be offensive to some players, so if you are easily upset by crap words then don't buy Viz the Game.

such terrific sales, Viz became a victim of its own success.

When Viz started out, it could truly claim to be a "cult" comic. The jokes were sharp and intelligent. But, like most potted success stories, Viz found that sales alone would not keep the magazine alive, and advertising in a magazine with such dubious content would be risky to say the least. Would Coke and Pepsi really





Stand up and be counted. With no sign of the Fat Slags anywhere, these three brave men decide to enter the race. You must choose from Biffa Bacon, Johnny Fartpants or Buster Gonad.

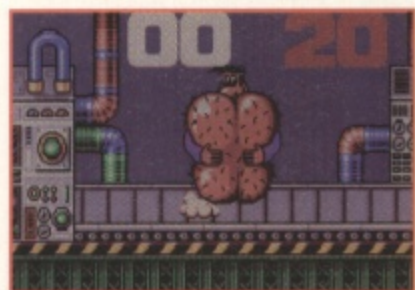

Ever wondered who inflates all those balloons at a royal wedding? Why they call in Johnny Fartpants. Johnny's favourite group is Earth, Wind and Fire and his fave movie Gone with the Wind.

But the phenomenon continues, as do numerous clone magazines that have popped up over the past few years (Zit, Toxic, The Damage, etc). As we all know, imitation is the sincerest form of flattery.

And so we come to the latest in a long line of Viz spin-off merchandising. After postcards, calendars, boxer shorts, T-shirts and even alarm clocks we now have the Viz computer game.

Viz the Game is based around a race between three of Viz's most infamous characters: Biffa Bacon, Johnny Fartpants and Buster Gonad. The race takes place over five stages, with the winner becoming the Viz champion of Fulchester. During the race, each character must take part in two bonus stages, specific

to the person under your control. For instance, Johnny Fartpants must use his undoubted bottom-blowing powers to inflate balloons. Meanwhile, Buster Gonad will be flattening pancakes with his unfeasibly large testicles, while Biffa Bacon must be assisted in drinking pints. The reward for your hard work will be extra tokens which increase your speed through the game.

Roger Irrelevant starts off the race in the middle of the countryside, with the whole of the event commentated on by the inimitable Roger Mellie. From the country, the race moves on



Roger Mellie gives an incisive and comprehensive rundown of events in the race through Fulchester. As you join us here, Biffa has just suffered a set-back, while Buster Gonad had bounced into the lead. But the race is only half run, and there's still a lot of work to do.



Biffa Bacon's bonus round allows the brute to accumulate power and gain bonus tokens by downing pints. The more you drink the further you get - although be sure not to get too legless during the race.



Here's Buster Gonad who's having trouble keeping up with the rest due to his incredibly large testicles. If you stray out of your lane too often, Rodney Rix will chuck bricks at you. When hit you lose time and gain a shame token. Three shame tokens mean you're out of the race.

to the town, a building site, a beach and finally a disco. You must win every section to become champ, although fail on just one leg and you'll have to re-race that section.

Like Virgin's previous comical tie-in *Monty Python*, *Viz the Game* just about manages to translate onto computer. Although to truly appreciate the game, you'll need to have read a good few issues of the comic.

AMIGA VIRGIN £19.99 • OUT NOW

GRAPHICS 80%
 X Poor animation, few backdrops.
 ✓ Detailed and colourful characters.

SOUND 73%
 X Painfully crap music throughout.
 ✓ In keeping with the feel of the game.

PLAYABILITY 79%
 X Only five courses; very repetitive.
 ✓ Accurately portrays the Viz characters.

ATARI ST

VIRGIN £19.99 • OUT NOW **79%**





DOUBLE DRAGON

Double the trouble as JB meets the Lee brothers

Brothers, eh, who needs 'em? Certainly not Billy Lee. He and his brother Jimmy grew up in the slums of the city, learning their martial arts skills as a necessary defence against the rough thugs of the streets. Sadly, they gradually grew apart but both retained their awesome fighting skills.

Now Billy is faced with his biggest challenge yet: the kidnapping of his girlfriend. Marion has been snatched

by the Black Warriors, an evil gang under the rule of the mysterious Shadow Boss. He alone must fight the whole gang – his brother's done a bunk – using whatever weapons come to hand: rocks, baseball bats, empty barrels, boxes, plus his own repertoire of oriental fighting moves. Billy has the arduous task of

fighting through the slums, factories and wooded outskirts of the city to reach the hide-out of the Shadow



Boss, only to find that he is, in fact, his brother Jimmy Lee. What a git, eh?

This brings us back to my original point, who needs brothers? All they do is nick all your toys when you're little, then all your girlfriends when you're older. It is all because of this rogue family member that you have to fight through four levels of bloody hard and stupidly big baddies, risking life and limb, in the hope of getting

BILLY'S BOVVER
By pressing the A button, you can pick up and throw any of these items that you'll find scattered around the floor.

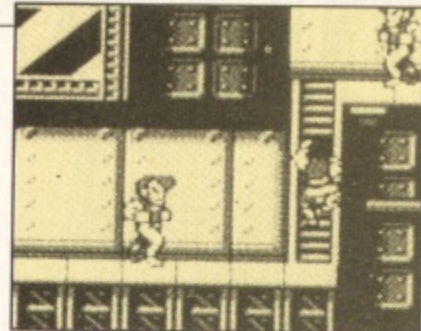
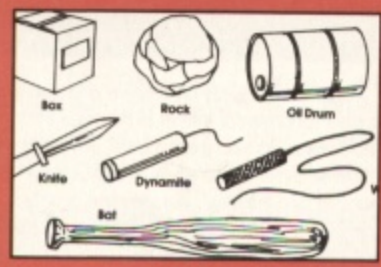

back the only steady girlfriend you're likely to see for a few years!

The graphics are quite superb, with backgrounds that would put many other bigger machines to shame – even in black and green. The only problem is that sometimes it is very difficult to work out which character you're controlling due to the blurred effect the Game Boy gives. The sound is very impressive, with a super in-game tune pounding away throughout. The effects aren't quite as imaginative, but the playability, in a good light, is easily as good as any other version of the game.

GAME BOY	GRAPHICS	83%
	<ul style="list-style-type: none"> ✗ Sometimes difficult to see who you are. ✓ Superbly detailed backdrops. 	
	SOUND	75%
	<ul style="list-style-type: none"> ✗ Unimaginative effects. ✓ Up-beat tune gets the adrenalin going. 	
GAME BOY	PLAYABILITY	78%
	<ul style="list-style-type: none"> ✓ Game Link compatible for two players. ✓ Large number of fight moves. 	
NINTENDO		78%
£19.99 • OUT NOW		

BALLOON KID

More brotherly trouble for Julian Boardman

Another family saga hits the Game Boy. This complete jerk called Jim decides he's going to have a mess around with a few balloons and entertain his sister (nuff said). Lo and behold; surprise, surprise; shock, horror; a gust of wind carries him away to a far distant land. But his clever sister, Alice, thinks of a way to save him. Yes, you've guessed it, she too decides to go for a ride hanging onto a load of balloons.

Despite all the evidence to the contrary, Jim does possess a modicum of intelligence and common sense, and addresses the problem of how Alice will find him. While Jim is floating through the air, he releases a balloon every few hundred yards or so in order that Alice can follow his trail. So Alice, in a clear case of the

heart ruling the head, flies off and tries to find Jim somewhere in the city of Pencilvania.

Balloon Kid basically ends up something like *Wonder Boy* in the air, but not quite as good. Alice has

THE CAST
Alice – the heroine who is out to rescue her brother Jim.
Jim – the little rascal who's caused untold grief for his big sis'.
Samm – Alice's eternal rival who pops up in the Game Link option.

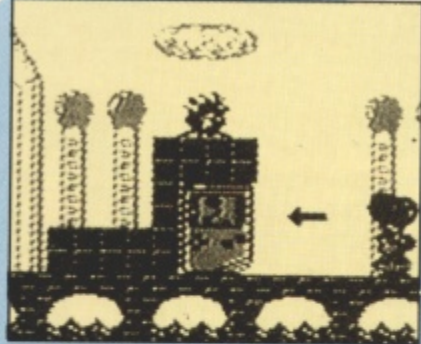

During the stages you occasionally come across a Game Boy (!). Entering it will get you into a bonus stage where you have to collect 20 balloons in order to gain an extra life.

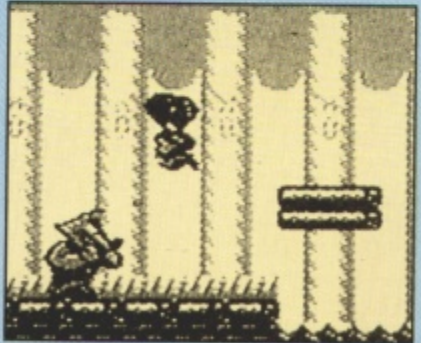

The big chap at the bottom is an area boss. One of these guys appears at the end of every other of the eight stages.

to float her way past various birds and creatures determined to pop her balloons and ruin her chance of ever seeing her cute, but mischievous little brother.

There's also a two-player Game Link version where you compete for the balloons with your friend Samm and a simple Balloon Trip game where there are no birds or fires.

Despite the corny storyline, horribly cute main characters, and the similarity with other platform games, I must admit that *Balloon Kid* did actually keep me playing for quite a long while. If you've got a spare £20, you could do a lot worse than swapping it for this.

GAME BOY	GRAPHICS	75%
	<ul style="list-style-type: none"> ✗ Simplistic backgrounds. ✓ Small but very clear sprites. 	
	SOUND	78%
	<ul style="list-style-type: none"> ✓ Amusingly cute sound effects. ✓ Pleasant background music. 	
GAME BOY	PLAYABILITY	73%
	<ul style="list-style-type: none"> ✗ Very repetitive gameplay. ✓ Two-player option is great. 	
NINTENDO		75%
£19.99 • OUT NOW		

DIAL-A-TIP CHEAT-LINE



for cheats, tips, pokes and secrets on all computer and console games ring now on

0898-10-1234

PRIZES FOR BEST CHEATS, TIPS, ETC.
Send to: P.O. Box 54, Southwest Manchester M15 4LY

Proprietor: Jacqueline Wright. Please ask permission of the person who pays the bill calls charged at 34p per min 'Cheap Rate' 45p per min at all other times.

STEVE JACKSON'S GLADIATORS OF THE ROMAN EMPIRE



LIVE COMBAT IN ANCIENT ROME



£100 WEEKLY PRIZE

0898 800 891

Calls are more expensive than ordinary telephone calls and should only be made with the permission of the subscriber. Calls cost 34p per min cheap and 45p per min all other times. Computerdial Ltd., Guildford, Surrey GU1 4JU.

Where can I get Game Boy, Genesis, Nintendo, Turbo Grafx, Neo Geo, Lynx and more for prices 50% less than what I'm paying now?

Buy calling The Ultimate Game Club and getting American Games at American Prices; For example:

Video System	Avg Price in Pounds		# Games Avail	Adapter to Play on UK?
	Per Game	Per System		
Nintendo	\$15-30	NA	400	Yes -\$25
Game Boy	\$12.50-15	\$45	100	No
Lynx	\$17.50-20	\$50	25	NA
Sega 8-Bit	\$15-25	NA	100	NA
Genesis	\$15-35	NA	60	No
Mega Drive	\$20-30	\$85	100	Yes- \$15
Turbo Grafx	\$15-35	NA	60	Yes- \$25
PC Engine	\$20-30	\$95	200	No
Neo Geo	\$100	\$225 RGB 12		No
Game Gear	\$15-20	\$80	5	No

And the best part about it is that all games from the USA play in English and have English instructions- perfect for RPG fans.

Approximate shipping costs for fast 2 day service (UPS Blue or FedEx) is \$20 for the 1st game, \$2 each additional. For 5-10 day service US Mail is \$10 for the 1st and \$1.50 for each additional. Customs duty is 15% on your total order not including postage. You do not pay us the customs!

A Genesis game is the American version of a Mega Drive game. A Turbo Grafx is the US Version of PC Engine. All other games are the same as the European version. The benefit of from us is 1) Pay 50% less for games. 2) Availability of 100s of more American games unavailable in Europe. 3) The games are released officially in the USA 1st, so now you can get them light years before the rest of Europe. Need we say more!

We also wholesale games for 10-30% less than the prices in this ad to shops and distributors in Europe. But you must be a registered business to buy wholesale

For Retail sale call **The Ultimate Game Club: 010-1-203-388-6741.**

For Wholesale call **Direct Distributors: 010-1-203-395-0851.**

Our Fax # for both: 010-1-203-388-0084.

Address for Retail: Address for Wholesale:

Ultimate Game Club

1491 Boston Post Road
Old Saybrook, CT. 06475

Direct Distributors

1491 Boston Post Road
Old Saybrook, CT 06475

We accept bank cheque, wire transfer, Mastercard, Visa, Discover, & American Express in US Dollars only. Your bank will convert this at no extra charge.

ACCESS/VISA
24HR MEGALINE
0732 351220

MEGA MIX

(DEPT RAZE 6), ASHDEN WALK, TONBRIDGE, KENT. TN10 3RL

ALL ITEMS
SENT BY FIRST
CLASS POST



PRICE PROMISE!! WE WILL BEAT ANY PRICE IN THIS MAGAZINE THAT IS CHEAPER THAN OURS BY **£1** PRICE PROMISE!!

EXCHANGE SERVICE

FOR MEGA DRIVE OWNERS
NEW FOR OLD£10-£15
OLD FOR OLD£3-£7
(Please phone for details on other makes)

NINTENDO GAMEBOY

NINTENDO GAMEBOY£64.95
ALL NINTENDO GAMEBOY GAMES, SAVE **£10.00** OFF
USUAL R.R.P., IN OUR LIMITED OFFER NOW ONLY £19.95 EACH

SUPER FAMILIOM

NINTENDO SUPER FAMILIOM£225.00
FAMILIOM + ONE GAME£265.00
FAMILIOM + TWO GAMES.....£285.00

ALL FAMILIOM GAMES ONLY £42.

MEGADRIVE SPECIAL OFFERS

JAPANESE SPECIAL OFFERS
JAPANESE CONVERTOR£13.95
AV LEAD£7.95
TURBO JOYPAD£13.95
PRO 1 JOYSTICK£19.95
STRIDER£28.50

SEGA MEGADRIVE

PLUS ANY GAME UP TO £27.00
NOW ONLY **£134.95**

SEGA MEGADRIVE

PLUS ANY GAME UP TO £50.00
WORTH **£340.00 NOW ONLY £149.95**

MEGA MEGADRIVE OFFER

SEGA MEGADRIVE + SONIC THE HEDGEHOG +
MICKEY MOUSE + JOYPAD + TURBO JOYPAD.
WORTH **£285.00 NOW ONLY £185.00**

SEGA MEGADRIVE GAMES

Aero Blasters.....£31.95	Ghosts 'n' Ghosts.....£31.95	Space Harrier II.....£31.50
Afterburner.....£32.50	Golden Axe.....£29.50	Speedball.....£32.50
Alien Kid.....£31.95	Granada.....£29.95	Star Cruiser.....£29.95
Alienated Beast II.....£24.95	Gynoug.....£34.50	Strider.....£42.50
Altared Beast II.....£26.95	Hard Drive.....£29.95	Sub Attack.....£39.95
Atomic Robokid.....£29.95	Heavy Unit.....£31.95	Super Airwolf.....£32.95
Arnie's Palmer Golf.....£32.50	Herzog Zwei.....£19.95	Super Baseball.....£29.95
Balman.....£32.50	James Pond.....£39.95	Super Basketball.....£26.95
Battle Goller.....£34.50	Joe Montana's Football.....£34.95	Super Hang On.....£27.50
Buddhan.....£34.95	John Madders Football.....£34.95	Super Monaco GP.....£32.95
Buster Douglas Boxing.....£34.95	Kageki.....£31.95	Super Shinobi.....£32.50
Crackdown.....£32.95	Lakers V Celtics.....£34.95	Super Thunderblade.....£31.95
Dangerous Seed.....£29.95	Last Battle.....£32.95	Super Volleyball.....£32.50
Darius 2.....£32.50	Magical Hat.....£32.50	Sword of Soudan.....£34.50
Dick Tracy.....£32.50	Midnight Resistance.....£34.50	Sword of Vermillion.....£44.95
DJ Boy.....£24.95	Mickey Mouse.....£34.95	Techno Cap.....£39.95
Dynamite Duke.....£31.95	Mowwler.....£29.95	Their Hair.....£34.95
Elemental Master.....£27.95	New Zealand Story.....£26.95	Thunderforce II.....£34.50
E-Swat.....£26.95	PGA Golf Tour.....£39.95	Twin Hawk.....£31.95
Fantasy Soldier.....£39.95	Phantasy Star 2.....£44.95	Wonderboy in Monster Lair.....£32.50
Final Blow.....£32.50	Rambo II.....£31.50	Volleyed.....£31.95
Forbidden City.....£34.95	Ringside Angel.....£34.95	Wonderboy III.....£31.95
Forgotten Worlds.....£32.50	Shadow Dancer.....£34.95	World Cup Soccer.....£24.95
Galates.....£34.95	Shining & Darkness.....£31.95	Wrestle Ball.....£31.50
Gain Ground.....£26.95	Sonic the Hedgehog.....£34.95	Wrestle War.....£31.50
Ghostbusters.....£24.95	Sorcerer.....£29.50	Zany Golf.....£34.50

MEGA HIRE SERVICE

MEGADRIVE GAMES£4.00 per week
GAMEBOY GAMES£3.50 per week
FAMILIOM GAMES£5.00 per week
(Please phone for details)

ATARI LYNX

ATARI LYNX£74.95
SAVE **£5.00** OFF OUR USUALL PRICE OF
£28.95 AND PAY ONLY £23.95 FOR ANY ATARI LYNX GAME. (ONLY WHILE STOCKS LAST)

SEGA GAMEGEAR£99.95

ALL GAMEGEAR GAMES , SAVE **£5.00 NOW ONLY £23.95.**
SUPER MON GP BASEBALL WONDERBOY
COLUMNS ZAMGEAR MAZE SYNDROME
PENGU MICKEY MOUSE G.G SHINOBI
G-LOC DRAGON CRYSTAL

MEGADRIVE MEGA OFFERS

SEGA MEGADRIVE OFFERS

LIMITED OFFER
ANY ONE OF THE NEW
JAPANESE GAMES
LISTED BELOW ONLY
£24.00 EACH

ESWAT	SUPER BASKETBALL	MAGICAL HAT
GHOSTBUSTERS	WONDERBOY 3	SHADOW DANCER
MICKEY MOUSE	DARRIN 481	FIST OF WORTH STAR
CRACKDOWN	CURSE	KING OF THE SWORD 2
WHIRLISH	INSPECTOR X	HURRICANE
HELLFIRE	CYBERBALL	XOR
BURNING FORCE	ARROW FLASH	DYNAMITE DUKE
DJ BOY	GAIN GROUND	

TO ORDER, PLEASE STATE ITEMS YOU REQUIRE, TOGETHER WITH PAYMENT, MADE PAYABLE TO 'MEGA MIX' OR PLACE YOUR ORDER ON OUR CREDIT CARD HOTLINE 0732 351220.
OVERSEAS ORDERS ADD £5. ALL PRICE ABOVE INCLUDE VAT, POSTAGE & PACKING.

MEGAMIX SOFTWARE (DEPT RAZE 6) 46 ASHDEN WALK, TONBRIDGE, KENT, TN10 3RL



FAMICOM
 FAMICOM + 2 JOYPADS
 + 2 FREE GAMES299.00
 ACT RAIZER.....37.00
 BOMBUZAL.....24.00
 BIG RUN.....25.00
 DARIUS TWIN.....40.00
 F-ZERO.....38.00
 FINAL FIGHT.....37.00
 GRADIUS III.....37.00
 PILOT WINGS.....39.00
 POPULOUS.....39.00
 S GRADE BATTLE.....39.00
 SUPER MARIO
 WORLD.....37.00
 HOLE IN ONE GOLF.....37.00
 ACTRA MAN.....39.00

LYNX
 LYNX CONSOLE + PSU +
 CALIFORNIA GAMES.....117.99
 LIGHTER POWER
 ADAPTOR.....11.95
 ALL GAMES FROM.....21.95

K's Computer Emporium

37, Pinfold Gate, Loughborough
 Leics, LE11 1SG
 TEL: (0509) 211799
 FAX: (0509) 881600

Open 9.30am to 6.30pm
 Everyday Except Sunday

PC ENGINE
 PC GT HAND HELD AND
 FREE GAME.....265.00
 JACKIE CHAN.....29.00
 COMBAT POLICE 2.....29.00
 LEGEND OF HEROES
 TOMA.....34.00
 VOILENT SOLDIER.....24.00
 MOTOR ROADER 2.....CALL
 HELL EXPLORER.....24.00
 YOKAI DOCHUKI.....10.00

WE ALSO BUY AND PART
 EXCHANGE USED
 CARTRIDGES. MANY MORE
 LATES T TITLES FOR OTHER
 CONSOLES AND COMPUTERS
 IN STOCK. PLEASE
 PHONEFOR MORE DETAILS
 AND ASK FOR ADAM OR PETE.
 TRADE ENQUIRIES WELCOME.

GAME GEAR
 SEGA GAMEGEAR + PSU99.95
 SEGA GAMEGEAR
 AND 3 GAMES.....159.95
 SUPER MONACO GP.....23.00
 BASEBALL 91.....24.00
 DEVILISH.....19.00
 MICKEY MOUSE.....24.00
 PSYCHIC WORLD.....19.00
 WOODY POP.....23.00
 COLUMNS.....19.00
 FORBIDDEN PLANET.....CALL
 G-LOCK.....19.00
 HEAD BUSTERS.....19.00
 JUNCTION.....23.00
 KENETIC
 CONNECTION.....19.00
 PENGU.....23.00
 RYUKUY.....CALL
 SHINOBI.....24.00
 SWEAK.....CALL
 SOKO BAN.....19.00
 WONDERBOY.....23.00
 WOODY POP.....23.00
 CALL FOR NEW RELEASES

MEGADRIVE
 UK MEGADRIVE + JPAD.....149.95
 JPN MEGADRIVE + #33
 GAME + FREE
 HEADPHONES.....129.95
 JPN GAME ADAPTOR.....9.95
 ARCADE POWER STICK.....32.00
 SCART LEAD.....12.95
 AERO BLASTERS.....33.00
 BATTLE SQUADRON.....28.00
 CURSE.....16.00
 DARIUS II.....28.00
 DEVIL HUNTER.....33.00
 ESWAT.....19.00
 ELEMENTAL MASTER.....28.00
 FATMAN.....28.00
 FANTASY SOLDIER III.....35.00
 GYNOUG.....30.00
 HARD DRIVIN.....28.00
 HELL FIRE.....19.00
 ITALIA 90.....33.00
 JAMES POND.....38.00
 J MADDEN AMERICAN
 FOOTBALL.....30.00
 KLAX.....23.00
 MAGICAL HAT.....22.00
 MICKEY MOUSE.....22.00
 MIDNIGHT RESISTANCE.....34.95
 PGA TOUR GOLF.....38.00
 RINGSIDE ANGELS.....32.00
 SHADOW DANCER.....22.00
 STRIDER.....27.00
 SUPER MONACO GP.....33.00
 SUPER REAL
 BASKETBALL.....33.00
 VOLFIELD.....28.00
 WHIP RUSH.....16.00
 WONDERBOY III.....23.00
 BUSTER DOUGLAS
 BOXING.....33.00
 BY MINI RUN.....CALL
 DICK TRACEY.....28.00
 KAZAKI.....34.00
 LAKERS V CELTICS.....37.00
 SONIC THE HEDGEHOG.....CALL
 SUPER AIR WOLF.....32.00
 STORM LORD.....CALL
 TASK FORCE WARRIOR.....CALL
 VERY TECH.....33.00
 WINGS OF WAR.....CALL
 ZANY GOLF.....22.00

NINTENDO
 NINTENDO FROM 75.00
 PYTHON 2 JOYSTICK.....8.99
 CART CLEANING
 KIT.....9.99
 BAYON BILLY.....37.00
 BLACK MANTA.....35.00
 DOUBLE DRAGON.....37.00
 MEGA MAN II.....38.00
 PAPERBOY.....38.00
 PINBOT.....37.00
 PROBOTECTOR.....37.00
 SNAKE RATTLE
 ROLL.....37.00
 SOLAR JETMAN.....38.00
 SUPER OFF ROAD.....23.00
 FOUR PLAYER
 LINK.....29.95
 CALL FOR ALL SECOND HAND
 SWAPS AND GAMES

GAME BOY
 GAMEBOY + GAME + P&P 65.00
 GAMELIGHT 9.95
 MAGNIFIER 9.95
 HARD CARRY CASE 9.95
 ASTRO RABBY 19.00
 CHASE HQ 19.00
 REVENGE OF GATOR 19.00
 ROBOCOP 24.00
 SPIDERMAN 19.00
 T.M.N. TURTLES 24.00
 BALLOON KID 19.00
 BUBBLE KID 19.00
 FORTRESS OF FEAR 19.00
 GHOST BUSTERS 24.00
 HAL WRESTLING 24.00
 HELANKY ALIEN 19.00
 JEOPARDY 24.00
 KING OF THE ZOO 19.00
 KUNG FU MASTER 24.00
 MARU S MISSION 19.00
 NFL FOOTBALL 24.00
 NINJA BOY 19.00
 OPERATION C 24.00
 POWER MISSION 19.00
 SNOOPY 19.00
 TASMANIA STORY 19.00
 W W S SUPERSTARS 22.00

Name:.....
 Address:.....
 Post Code:..... Tel:.....
 Item Cost
 £
 £
 £
 £
 Add £1 per order, Sub Total £
 Plus £5 per console for p+p Total £
 Expiry Date: / / Signature.....
 CHEQUE / P.O. / ACCESS / VISA / MASTER CARD

WANTED

 USE YOUR VOICE
 TO OUTDRAW THE
 GUNFIGHTER
 DEAD OR ALIVE CASH PRIZES
0898 31 35 69
 INFODIAL POBox 36 LS1 4TN Call charges 34p Per Min Cheap 45p Per Mln All Other Times

**FAMICOM, LYNX + GAME GEAR
 CARTRIDGE HIRE SERVICE**
 FUTURE-HIRE GIVES YOU THE CHANCE TO:
 HIRE,BUY,SELL OR EXCHANGE ANY TITLE ON THESE CONSOLES.
 HIRE ANY LYNX OR GAME GEAR TITLE-ONLY 2.50 PER WEEK
 HIRE ANY SUPER FAMICOM TITLE-ONLY 4.00 PER WEEK
 WE WANT YOUR OLD GAMES PHONE FOR BEST PRICES
HARDWARE & SOFTWARE
 SCART SUPER FAMICOM + GAME ONLY 280.00
 ATARI LYNX + GAME ONLY 125.99
 SEGA GAME GEAR + GAME ONLY 129.99
 SUPER FAMICOM GAMES - 41.00 EACH
 ATARI LYNX GAMES - 24.99 EACH
 FOR FULL DETAILS SEND S.A.E. TO:-
 FUTURE-HIRE
 36 VICTORIA ROAD, FERNDOWN
 WIMBOURNE, DORSET, BH22 9HZ
 OR PHONE BETWEEN 9 am - 5 pm
 0202 894309 LEAVE NAME + ADDRESS
 (FOR FULL DETAILS)
 PHONE (0202) 894309AFTER 5pm

CONSOLE SOFTWARE HIRE CLUB
 LIFE MEMBERSHIP £10 (INCLUDES ONE FREE HIRE)
7 DAY HIRE PERIOD
 HIRE ANY TITLE FOR ONLY
 SUPER FAMICOM - £3.50
 SEGA MEGADRIVE - £3.00
 PC ENGINE - £3.00
 GAMEBOY - £2.50
 ATARI LYNX - £2.50
 SEGA GAME GEAR - £2.50
SECOND HAND GAMES WANTED
 PLEASE SEND ME YOUR INFORMATION PACK
 NAME.....
 ADDRESS.....
 POSTCODE.....
 I OWN THE FOLLOWING CONSOLES
 DWM, 122 STRATHERN ROAD, DUNDEE, DD5 1JW.
 TEL. 0382 74912. FAX. 0382 77709.

SEGA MASTER SYSTEM PRICE LIST

MASTER SYSTEM.....	£81.99	ENDURO RACER.....	£10.25	PHANTASY STAR.....	£40.99
MASTER SYSTEM PLUS.....	£99.99	ESWAT.....	£30.99	POSEIDEN WARS 3D.....	£30.99
CONTROL PAD.....	£ 7.20	F16 FIGHTER.....	£18.45	POWER STRIKE.....	£25.65
QUICKSHOT PYTHON 1.....	£10.25	FANTASY ZONE.....	£13.35	PRO WRESTLING.....	£25.65
QUICKSHOT MAVERICK 1.....	£16.40	FANTASY ZONE TM.....	£25.65	PSYCHIC WORLD.....	£30.99
QUICKSHOT FLIGHTGRIP 1.....	£ 9.25	FANTASY ZONE 11.....	£25.65	PYSCHO FOX.....	£30.99
HANDLE CONTROLLER.....	£40.99	FIRE & FORGET 11.....	£30.99	QUARTET.....	£25.65
LIGHT PHASER.....	£30.99	GAIN GROUND.....	£30.99	R.C. GRAND PRIX.....	£30.99
LIGHT PHASER + CART.....	£46.15	GALAXY FORCE.....	£30.99	R-TYPE.....	£30.99
RAPID FIRE UNIT.....	£ 6.15	GAUNTLET.....	£30.99	RAMBO III.....	£30.99
CONTROL STICK.....	£15.40	GANGSTER TOWN.....	£25.65	RAMPAGE.....	£30.99
MAINS ADAPTOR.....	£ 7.20	GHOSTBUSTERS.....	£30.99	RASTAN.....	£30.99
ACES OF ACES.....	£33.99	GHOST HOUSE.....	£18.45	RESCUE MISSION.....	£10.25
ACTION FIGHTER.....	£13.35	GHOULS & GHOSTS.....	£30.99	SCRAMBLE SPIRITS.....	£30.99
AERIAL ASSAULT.....	£30.99	GLOBAL DEFENCE.....	£13.35	SECRET COMMAND.....	£13.35
AFTERBURNER.....	£30.99	GOLDEN AXE.....	£30.99	SHANGHAI.....	£25.65
ALEX KIDD.....	£25.65	GOLDEN AXE HAMMER.....	£33.99	SHINOBI.....	£30.99
ALEX KIDD-HIGH TECH.....	£30.99	GOLFMANIA.....	£33.99	SHOOTING GALLERY.....	£25.65
ALEX KIDD-LOST STARS.....	£30.99	GOLVELLIUS.....	£30.99	SHOOTING GAMES.....	£25.65
ALEX KIDD-SHINOBI.....	£30.99	GREAT BASEBALL.....	£25.65	SLAP SHOT.....	£30.99
ALIEN SYNDROME.....	£30.99	GREAT BASKETBALL.....	£25.65	SPACE HARRIER.....	£30.99
ALTERED BEAST.....	£30.99	GREAT FOOTBALL.....	£25.65	SPACE HARRIER 3D.....	£30.99
AMERICAN BASEBALL.....	£30.99	GREAT GOLF.....	£25.65	SPELLCASTER.....	£30.99
AMERICAN PRO FOOTBALL.....	£30.99	GREAT VOLLEYBALL.....	£25.65	SPY VS SPY.....	£18.45
ASSAULT CITY.....	£30.99	HANG ON.....	£10.25	SUBMARINE ATTACK.....	£30.99
ASTRO WARRIOR/PITPOT.....	£25.65	HEAVYWEIGHT CHAMP.....	£25.65	SUPER MONACO GRAND PRIX.....	£30.99
AZTEC ADVENTURE.....	£13.35	IMPOSSIBLE MISSION.....	£30.99	SUPER REAL BASKETBALL.....	£25.65
BANK PANIC.....	£18.45	INDIANA JONES.....	£30.99	SUPER TENNIS.....	£10.25
BASKETBALL NIGHTMARE.....	£30.99	JOE MONTANA FOOTBALL.....	£30.99	TEDDY BOY.....	£10.25
BATTLE OUT RUN.....	£30.99	JUNGLE FIGHTER.....	£30.99	TENNIS ACE.....	£30.99
BLACK BELT.....	£25.65	KENSEIDEN.....	£30.99	THUNDERBLADE.....	£30.99
BLADE EAGLE 3D.....	£30.99	KUNG FU KID.....	£25.65	TIME SOLDIERS.....	£30.99
BOMBER RAID.....	£30.99	LORD OF THE SWORD.....	£30.99	TRANSBOT.....	£10.25
CALIFORNIA GAMES.....	£30.99	MAZE HUNTER 3D.....	£30.99	ULTIMA IV.....	£40.99
CAPTAIN SILVER.....	£30.99	MICKEY MOUSE.....	£30.99	VIGILANTE.....	£30.99
CASINO GAMES.....	£30.99	MIRACLE WARRIOR.....	£33.99	WANTED.....	£25.65
CHASE HQ.....	£30.99	MISSILE DEFENCE 3D.....	£30.99	WONDERBOY.....	£25.65
CHOPLIFTER.....	£25.65	MONOPOLY.....	£30.99	WONDERBOY-MON/LAND.....	£30.99
CLOUD MASTER.....	£30.99	MOONWALKER.....	£30.99	WONDERBOY III.....	£30.99
COLUMNS.....	£25.65	MY HERO.....	£18.45	WORLD CUP ITALIA 90.....	£25.65
CYBER SHINOBI.....	£30.99	NINJA.....	£10.25	WORLD GAMES.....	£25.65
CYBORG HUNTER.....	£25.65	OPERATION WOLF.....	£30.99	WORLD GRAND PRIX.....	£13.35
DEAD ANGLE.....	£30.99	OUT RUN.....	£30.99	WORLD SOCCER.....	£25.65
DICK TRACEY.....	£30.99	OUT RUN 3D.....	£30.99	Y'S.....	£33.99
DOUBLE DRAGON.....	£30.99	PAPERBOY.....	£30.99	ZAXXON 3D.....	£30.99
DOUBLE HAWK.....	£30.99	PARLOUR GAMES.....	£18.45	ZILLION.....	£25.65
DYNAMITE DUX.....	£30.99	PENGUIN LAND.....	£30.99	ZILLION II.....	£25.65

SEGA MEGADRIVE PRICE LIST

MEGADRIVE.....	£189.99	GHOSTBUSTERS.....	£35.99	STRIDER.....	£46.15
POWERBASE CONVERTOR.....	£30.99	FORGOTTEN WORLDS.....	£35.99	SPACE HARRIER II.....	£35.99
ARCADE POWER STICK.....	£35.99	GHOULS N GHOSTS.....	£46.15	SUPER HANG ON.....	£35.99
AUDIO-VIDEO CABLE.....	£8.20	GOLDEN AXE.....	£35.99	SUPER LEAGUE BASEBALL.....	£35.99
CONTROL PAD.....	£15.40	HERZOG ZWIE.....	£35.99	SUPER MONACO G.P.....	£35.99
AFTERBURNER II.....	£35.99	J. MADDENS AMERICAN F.BALL.....	£40.99	SUPER REAL BASKETBALL.....	£35.99
ALEX KIDD-ENCH. CASTLE.....	£30.99	JAMES POND.....	£40.99	SUPER THUNDERBLADE.....	£35.99
ALTERED BEAST.....	£35.99	LAST BATTLE.....	£35.99	SWORD OF THE VERMILLION.....	£51.25
ARNOLD PALMER T.GOLF.....	£35.99	MICKEY MOUSE.....	£40.99	SWORD OF THE SODAN.....	£40.99
BATTLE SQUADRON.....	£40.99	MOONWALKER.....	£35.99	THUNDERFORCE II.....	£35.99
BUDOKAN.....	£40.99	MYSTIC DEFENDER.....	£35.99	TRUXTON.....	£35.99
CRACKDOWN.....	£35.99	P.G.A TOUR GOLF.....	£40.99	TWIN HAWK.....	£35.99
COLUMNS.....	£30.99	RAMBO III.....	£30.99	WONDERBOY III MON. LAIR.....	£35.99
CYBERBALL.....	£35.99	PHANTASY STAR II.....	£61.50	WORLD CUP ITALIA 90.....	£30.99
DYNAMITE DUKE.....	£35.99	POPULOUS.....	£40.99	ZANY GOLF.....	£40.99
ESWAT.....	£35.99	REVENGE OF SHINOBI.....	£35.99	ZOOM.....	£30.99
GAINGROUND.....	£35.99	SHADOW DANCER.....	£35.99	ELIMINATOR CLEANING KIT.....	£11.99



ALL ORDERS WILL BE SENT
ASAP PRICES INCLUDE VAT.
PLEASE SEND PAYMENT WITH
ORDER ADD £2 FOR DELIVERY

TV GAMES

THE SEGA SHOP

OUR SHOP
IS NOW
OPEN

11 CASTLE PARADE, EWELL BY-PASS, EWELL, SURREY KT17 2PR
TEL: 081 786 7816 FAX: 081 786 7192
MOBILE: 0831 520474

TV GAMES IS AN OFFICIAL
SEGA STOCKIST UK
VERSIONS ONLY

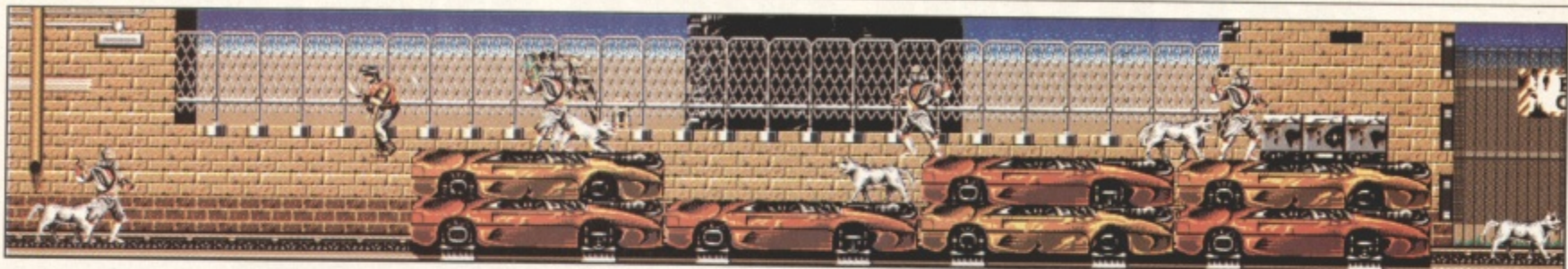

SHADOW DANCER

Julian Boardman invites you to come dancing – doggy style

Since this sequel to *Shinobi* arrived in the arcades two years ago (and you all thought it was *Revenge of Shinobi* that was the sequel), each different conversion has taken on its own little plot line and subtitle – my own per-

first *Shinobi* adventure, he deserves a rest and has set off around the world to visit all his friends. While visiting his chum Kato in New York, he is horrified to find that Kato's flat has been ransacked and his friend

worked around any hardware limitations on the quality of the background graphics to produce a game that stands up well to its arcade counterpart, both in looks and playability. The five frenetic levels are bal-

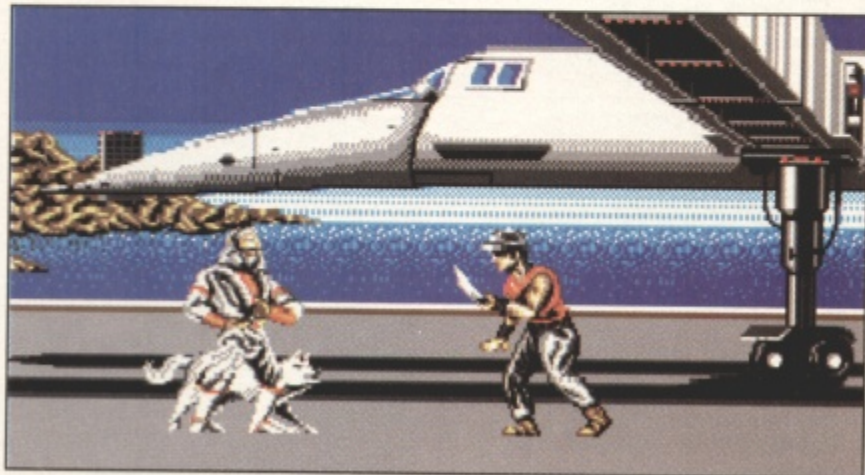

The action begins inside JFK airport, the first target for the terrorists' bombs. You and your dog must fight your way through three stages to get to the end of level boss who's based on a 737.

hacked and slashed by what appear to be indiscriminate thugs (hey, that's life in the big city).

However, on contacting Kato's acquaintances, Mushy discovers that his friend was close to uncovering the full details of a terrorist plot to bring the city to its knees. It transpires that the evil-doers are planning to plant firebombs at strategic points throughout the city.

Mushy decides to avenge his mate's death and save the city. With the help of Kato's dog Ninja, Joe sets out to do his bit as the all-American ninja hero.

US Gold have done a fine job of the computer conversion. They have

anced just right. The early levels are short enough not to become a pain every time you play, but taxing enough to make you concentrate every step of the way.

On the down side, *Shadow Dancer* is fairly old now and doesn't stand out from an already large number of similar ninja beat-'em-ups. Even so, it is a good product and if you lack a *Shinobi* game, this could amply fill that gap in your collection.

ATARI ST £24.99 • OUT NOW **US GOLD**

GRAPHICS **80%**
 ✓ Arcade quality graphics.
 ✓ Avoids repeating backgrounds.

SOUND **79%**
 ✗ Limited SFX on 512K machines.
 ✓ A classic rendition of the *Shinobi* tune.

PLAYABILITY **83%**
 ✓ Five levels of highly intense action.
 ✓ Added novelty of sending in Shep.

AMIGA

US GOLD £24.99 • OUT NOW **82%**

GRAPHICS **81%**
 ✓ Identical map to arcade version.
 ✓ Superb use of colour on characters.

SOUND **82%**
 ✓ Atmospheric soundtrack.
 ✓ Huge number of great sound effects.

PLAYABILITY **82%**
 ✗ Too similar to every other ninja game.
 ✓ Fast, familiar and friendly.

MEGA DRIVE

SEGA ETBA • TBA **82%**

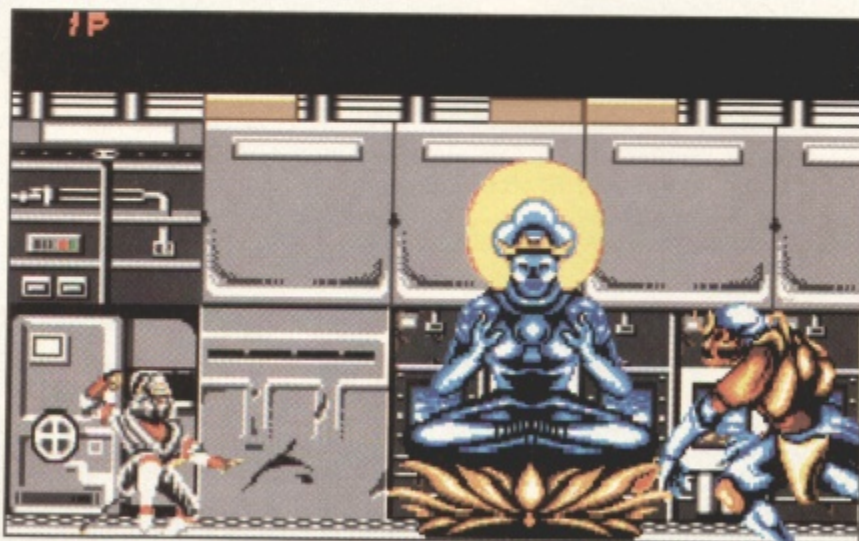

sonal favourite being "One Man and his Dog". In this case, the plot goes something like this. Joe Mushasi, or Mushy to his friends, has decided that after the incredible ordeal of the

The chap on the right is the boss at the end of the first stage. He is vulnerable on his upper arms to shurikens or all over to magic. This explains the presence of the Buddha figure whom you've summoned to give the boss some hell.





CONSOLE YOURSELF WITH.....



MAIL ORDER

C.E.S.

MAIL ORDER

9am-6pm (Mon-Sat)

9am-6pm (Mon-Sat)

DEPT (RAZE). 153 Whitehart Lane, Barnes, London, SW13 0PS Tel: 081-876-5501, Fax: 081-876-5501

MEGADRIVE

SEGA MEGADRIVE (PAL) + GAME.....£139.99 (+£5 P+P)

GAMES	GAMES	SPECIALS
AEROBLASTER.....32	JAMES POND34	ANY GAME BELOW @ £25.00
BATMAN35	JOHN MADDEN39	ATOMIC ROBOKID
BATTLE SQUADRON35	JOE MONTANA39	ELEMENTAL MASTER
BIMINI RUN.....36	LAKERS V CELTICS39	FATMAN
BUDOKAN.....36	MIDNIGHT RESISTANCE38	HARD DRIVIN
CRACK DOWN.....32	POPULOUS.....36	HEAVY UNIT
DICK TRACY32	SONIC THE HEDGEHOGCALL	GRANADA X
GYNOUG.....35	SUPER MONACO G.P.36	SUPER VOLLEY BALL
FLICKEY.....32	SWORD OF VERMILLION49	MICKY MOUSE
NEW: BONANZA BROS35	VALIAS III.....35	SOKOKAN
	VERYTEX35	DAI SAN PU

FAMICOM

FAMICOM (SCART)
+ 2 GAMES299.99
(+£6P+P)

FAMICOM (PAL)
+ 2 GAMES320.00
(+£6 P+P)

SPECIALS

BIG RUN.....30

HOLE IN ONE.....32

POPULOUS.....25

BOMBUZAL.....25

GAMES

ULTRAMAN47

DARIUS TWIN48

3D GOLF48

GRADIUS III.....45

PILOT WINGS.....45

ACTRAIZER.....42

FINAL FIGHT45

F-ZERO.....40

MARIO WORLD40

SIMCITY.....48

R-TYPECALL

PC ENGINE G.T
+ GAME.....240.00

ACCESSORIES

SEGA PAD14.99

ARCADE POWER STICK.....34.99

ENG/JAP CONVERTOR.....9.99

POWER PACK9.99

GAMEBOY CARRY CASE14.99

GAME LIGHT.....12.99

LIGHT BOY24.99

GAMEBOY AMPLIFIER.....14.99

GAMEBOY

GAMEBOY SYSTEM

DELUXE69.99

GAMEGEAR

GAMEGEAR +GAME 140

GAMES

MICKY MOUSE.....25

CHASE HQ.....25

HEADBUSTERS.....25

SHINOBI.....28

GOLF.....28

SHANGHAI.....20

MATH YOUNG20

GAMEBOY GAMES

ALL AT £24.99 EACH

CHESS MASTER

ROBOCOP

GREMLINS II

PIPEDREAM

BUBBLE BOBBLE

NFL FOOTBALL

SOLOMANS CLUB

WWF WRESTLING

BUGS BUNNY

BURAI FIGHTER

BATTLE BALL

OPERATION C

DRAGONS LAIR

KUNG FU MASTERS

PACMAN

FINAL FANTASY.....29.99

LEGEND.....29.99

F1 RACE.....29.99

SPECIALS

SPIDERMAN.....12.99

BUBBLE GHOST.....12.99

TASMANIAN STORY.....12.99

WHOLESALE / EXPORT WELCOME

CHEQUES / P.O. TO C.E.S

PLEASE ADD £1.00 P+P FOR GAMES £2 FOR ACCESSORIES

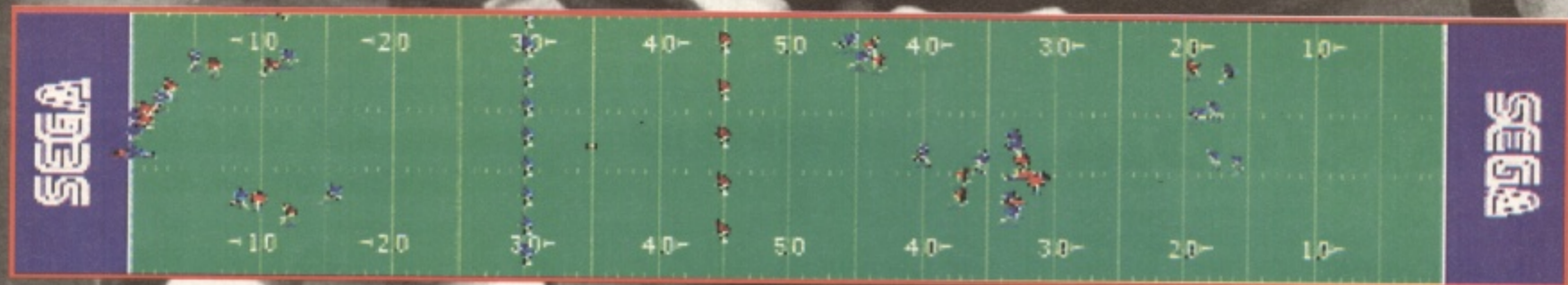
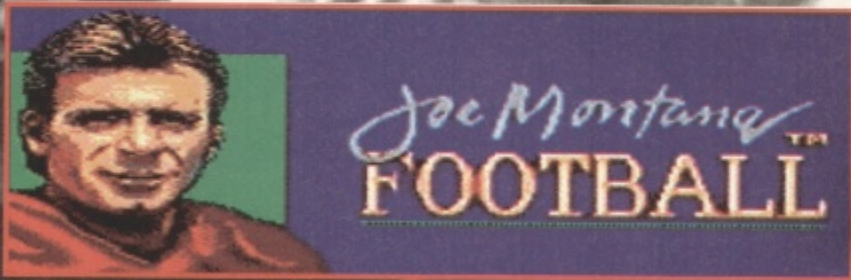
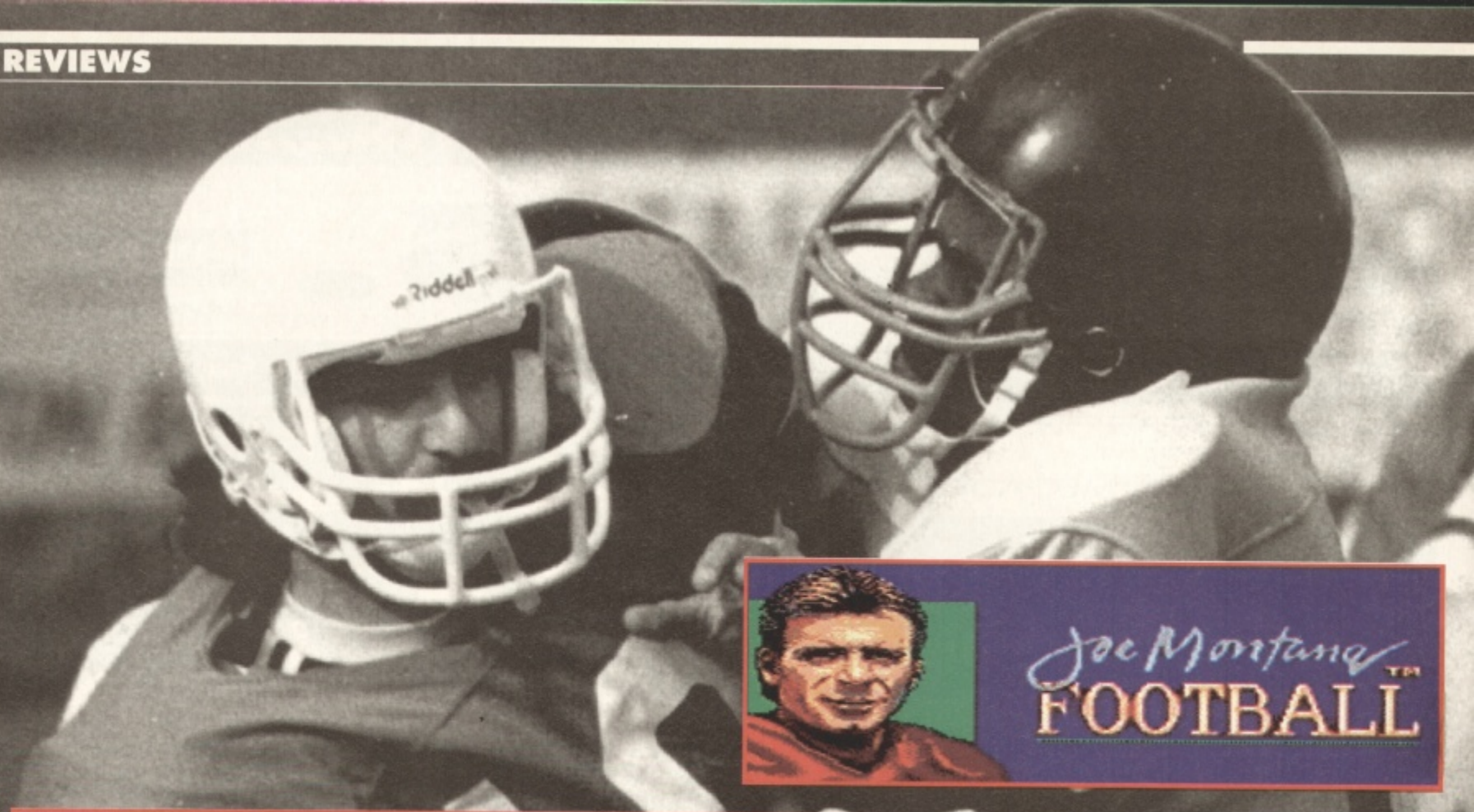

The SF 49ers' quarterback decides to boost his pension by endorsing a game. Julian Boardman checks out the size of his superannuation



Anyone who saw this year's Superbowl from Tampa Bay will realise why football (not soccer) is so huge in America. The tension in that stadium, not to mention across the world (well, my mate's living room anyway), as the Bills' kicker stood up in the dying seconds to take the 50-yard field goal attempt, which would decide the outcome of the game, was remarkable. Despite what you may think of the typically OTT showbusiness rubbish that surrounds it, American football can still be one hell of a game.

Why then does *Joe Montana Football* on the Master System totally fail to capture any of that atmosphere? The PC version, though, is a completely different bag of jockstraps and is detailed later on in the review.

The Master System game is played over four five-minute quar-

ters between one or two players. The rules of American football apply where possible (things like foul rules don't make an appearance), four downs to move ten yards up

the pitch and so on. After the coin is tossed, the kick off takes place and the receiving team has possession. A play-select screen then comes up, giving you a choice of



JOE MONTANA

play depending on your situation: a defensive play, offensive play, field goal attempt or punt. During offense, Joe Montana's recommended play will be highlighted as Joe's Play. There is so little variety in the plays available that you might as well just go for that and let him get on with it.

The joypad gives control over the quarterback, so he can dodge tackles or run until the ball is passed. Control then goes to the receiver who can try to shake off his marker to make the pass complete; once he's got the ball, he can run like stink to gain as many yards as possible. Obviously the pass may be incomplete or intercepted just as in a real game.

Sadly that is where the similarity with the real game ends. The limited number of plays to select means that decision-making is

never a problem; the small sprites and perspectiveless side-on view result in confusion rather than speed, and once you have found a couple of plays that work well for you, it all becomes far too easy. Even before you get it sussed, JMF never becomes involving or addictive, barely diverting.

The game seems to have followed Joe Montana's recent form, down the pan.

PC strikes Gold

The PC version, designed by Sega and distributed by US Gold, is completely different. In fact the only similarities it has with the Master System version are the name and the daft picture of Joe "Aren't I big and tough?" Montana on the front.

The PC version is one of the most advanced American football simulators I have ever come

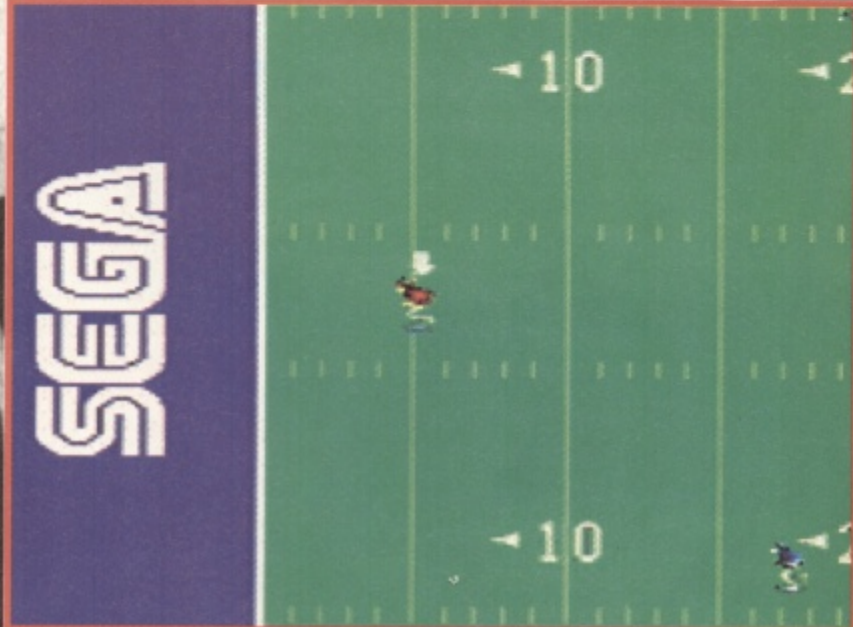

across. The wealth of options make it a game that can really appeal to someone who knows their running backs from their wide receivers; you can really get deep into it. On the other hand, after getting used to the plays and controls, it's the sort of game you can pop back to for a quick half hour bash.

Some of the advanced features include a playbook that allows you to design your own plays, a replay editor that lets you create your own highlight films of a game, and a huge database of players and teams from which you can mix and match to make the perfect side. Not only that, once you get used to the simple controls, the game soon becomes very playable. My only reservations about recommending it to anyone would be the irritating disk access for anyone running it from floppy. Get a hard drive!

The kick off punt is about to take place. If you receive a long kick in your end zone, it will probably be worth carrying the ball out at the back line to get a touchback. Doing this will give you an automatic first down on the 20-yard line.

JOE'S FOOTBALL LEXICON

Down - A chance for the offense to gain yardage. The offense has four downs to advance the ball towards the goal line. In order to keep the ball, the offense must either score or gain at least ten yards by the end of the fourth down.

First down - The offense's first play after the kick off. Whenever the offense gains ten yards, it earns another first down.

Line of scrimmage - Where the teams square up to begin each play. It is determined by where the ball rested at the end of the last play.

Safety - Taking your ball into your own end zone and being tackled there.

Results in change of possession and two points for your opponent.

Time out - Called by either team at the end of a play to allow for a quick strategy session. The clock stops during this session.

Touchback - Gaining possession of the opponent's ball in your end zone and being tackled there. Results in your team getting a first down at the 20-yard line.

MASTER SYSTEM	GRAPHICS 75%
	X Dull screen presentation, tiny sprites.
	✓ High quality end of game screen.
	SOUND 73%
X Truly naff title tune.	
✓ Nice crowd sounds though.	
PLAYABILITY 64%	
X Too shallow to be addictive.	
X A poor imitation of the real thing.	
SEGA 68%	
£29.99 • OUT NOW	

IBM PC	GRAPHICS 84%
	✓ Excellent all-round presentation.
	✓ Easy to distinguish characters.
	SOUND 81%
✓ Supports every soundcard - and more!	
✓ Great PC speech and decent effects.	
PLAYABILITY 82%	
X Long floppy disk access times.	
✓ Wide range of options enhance game.	
SEGA/US GOLD 82%	
£35.75 • OUT NOW	

MEGA DRIVE	SEGA
£35 • IMPORT	

A FOOTBALL

PICK UP A PORTABLE!

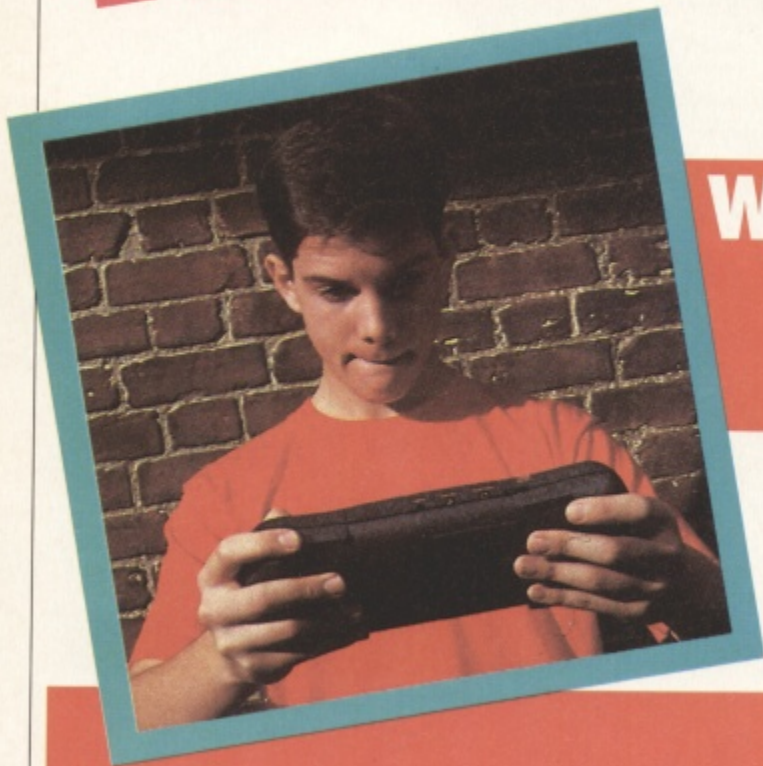

WIN A FABULOUS TOP-OF-THE-RANGE ATARI LYNX HAND-HELD GAMES CONSOLE!

There's a very good reason why the Atari Lynx has been voted console of the year by a panel of judges made up from journalists from over 30 international computer magazines:

- With its huge 4096 colour palette and 16 onscreen colours, the Lynx brings games to life.
- Its hardware sprites, rotation and zoom means you get games which offer near coin-op speeds and playability.
- The in-built four-channel sound chip provides unrivalled quality tunes, effects and sampled speech.
- Its unique flip mode rotates the image onscreen by 180° making it ideal for either right- or left-handed play.
- Via its multiplayer ComLynx adaptor, it's possible to enjoy games involving up to eight players simultaneously.
- You'll find more in a Lynx than most home computers.

But it's not just the Lynx's fabulous technical specifications that make it the top colour hand-held games console in the world. It's the ever-expanding range of top software that makes the Lynx much sought after by games players. With games like *Klax*, *Rygar*, *Rampage*, *Gauntlet III* and *Paperboy*, the Lynx is a portable arcade.

To get your hands on this phenomenal portable power house, you must simply answer the three questions in the box below. Fill in your name, address and answers in the form provided, and send the whole lot to *CuffLynx*, *RAZE*, Unit 3, 7 Back Street, Trowbridge, Wiltshire BA14 8LH. Entries to be received by June 24.

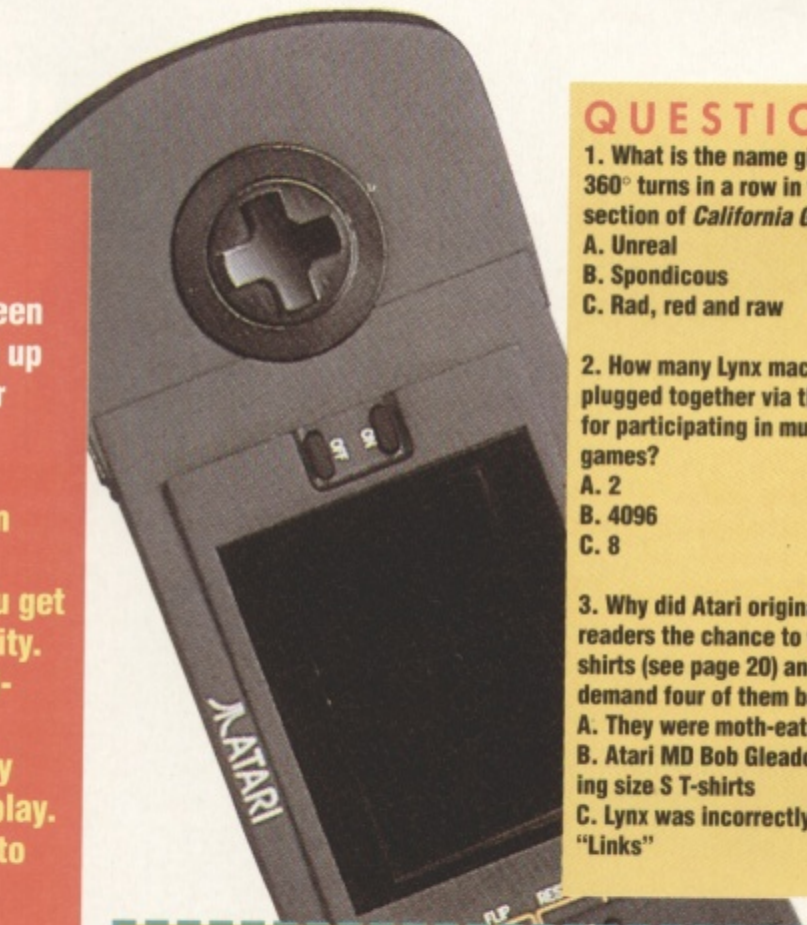

QUESTIONS

1. What is the name given to five 360° turns in a row in the surfing section of *California Games*?
A. Unreal
B. Spondicous
C. Rad, red and raw
2. How many Lynx machines can be plugged together via the ComLynx for participating in multiplayer games?
A. 2
B. 4096
C. 8
3. Why did Atari originally offer RAZE readers the chance to win 10 T-shirts (see page 20) and then demand four of them back?
A. They were moth-eaten
B. Atari MD Bob Gleadow likes wearing size S T-shirts
C. Lynx was incorrectly spelt as "Links"

THE MISSING LYNX

Yes, yes, yes! I really do want to win an Atari Lynx with ComLynx, mains adaptor and *California Games* cartridge...

1 A B C 2 A B C 3 A B C

Name.....
 Address.....
Postcode.....
 Phone number.....Size.....

PRO GAMES

MAIL ORDER

TEL: 081 769 9937

081 769 4688

FAX: 081 664 7239

10 MITCHAM LANE, STREATHAM, LONDON, SW16 6NN

MEGADRIIVE

MEGADRIIVE

Megadrive from £129.95
UK Convertor adapts
Japanese games to play on
English machines.

●
£24.95

DJ Boy, Mega Panel E-
Swat, Ghostbusters.

●
£29.95

Magical Hat, Mickey
Mouse, Hellfire, Shadow
Dancer Wonder Boy II Gain
ground, Dynamite Duke.

●
£34.95

Strider, Monster Hunter,
Dangerous Seed,
Elemental Master, Aero
Blasters, Super Air Wolf,
Heavy Unit, Musha Aleste

●
£39.95

Ka Ge Ki, Midnight
Resistance PGA Tour Golf
Lakers V Celtics.

GAME BOY

Game Boy Tetris Pack
£69.95

●
WWF £26.95

●
Fine Fantasy £29.95,

●
F1 Race + 4 Player adaptor
£29.95.

All other Game Boy games
£24.95,

Kung Fu Master, Robocop,
Batman, Serpent,
Dragons Lair, Bubble
Bobble, Duck Tales, TMNT,
Double Dragon,
Operation Contra.

●
Carry Cases from £17.95

NINTENDO

Converted Nintendo
required to run all
American games.

●
Conversion
£20.00 + £p+p

●
Nintendo American
games (converted) from
£34.95 - £44.95

●
WWF

Super Mario III
Double Dragon,
Turtles II
Jackie Chan,
Bart Simpson V s
Space Mutants
Mega Man III
Punisher.

FAMICOM

Famicoms from £299.95

●
Games,
Ultra Man, Pilots Wings,
Great Battle, Mario III,
F-Zero,

●
Act Raiser, Gradius III
Final Fight, Sim City,
Darius Twin, Final Fight,
Hole in one Golf.

GAME GEAR

Game Gear from £99.95

●
Games £29.95,
Ninja, G.Loc, Wonder
Boy, Mickey Mouse,
Dragon Crstal, Base ball,
Golf, Psychic World.

●
All old games £24.95.

LYNX

Lynx from £99.95
All Games £29.95. PC

●
ENGINE GT £249.95

**POSTAGE IN
LONDON
GAME POSTED
FREE OF
CHARGE.
CONSOLE £3.**

**OUTSIDE
LONDON
GAMES
£1
CONSOLES
£5**

**SECOND
HAND
GAMES
BOUGHT
AND
SOLD**

**TRADE
ENQUIRIES
WELCOME**

**PLEASE
MAKE
CHEQUES
PAYABLE
TO
PROGAMES**

FAMICOM

PENGIN

GAMEBOY

NINTENDO

LYNX

MACHINE SHACK SHOP : 081 769 6401

QUADREL

Julian Boardman gets out his crayons and plays with a Frenchman

There is a certain mathematical theorem that goes thus: any map or flat shape that is sub-divided into any number of different sections can be painted with four colours in such a way that no one section is painted with the same colour as a section adjacent to it. *Quadrel* is based around this theory.

The game presents you with a

number of different shapes each of which are divided into designs ranging from the simplistic to the convoluted. You then have to use your skill and judgement to paint all the sections with four colours – yellow, red, blue, green – in such a way that it follows the aforementioned theorem.

To make things slightly more difficult, you only have a limited number of colour in your paint pots. This could provoke a situation where one of the last few spaces could only take, say, a yellow, but you have unfortunately run out of paint. Should this happen or a space is surrounded by all four colours, meaning that no colour could be successfully placed there, then your game is over.

The game offers two solitary

The four paint pots show the colours that you can use; player one always uses the pots on the left. As you use up your paint, the pots become visibly emptier until the counter at the side reads zero. The clock in the middle is for timed games and works in a similar way to a chess clock, starting and stopping as your turn comes around.

Several strategies can be employed but none is more successful than using just two colours for a lot of the time, thus preventing a situation arising where one space is surrounded by all four colours



The more advanced levels soon become too complicated to give any chance of developing a strategy.



modes, voluntary and involuntary. What this means is that you either get a choice of where to paint or the computer decides which section must be filled next. The two-player modes, either against the computer or another player, are a race to see who can prevent the other player from making a move first.

Perhaps it is over my head but half the time it seems to be more luck than judgement that you succeed – especially on levels that include over a hundred tiny sections to paint. This gives it a “take it or leave it” feel and prevents *Quadrel* from ever becoming really gripping or addictive, only ever vaguely entertaining.

IBM PC LORICIEL
£24.99 ● OUT NOW

ATARI ST LORICIEL
£24.99 ● OUT NOW

AMIGA

GRAPHICS 77%
X Missed opportunity for original graphics.
✓ Nice animation on paint pots.

SOUND 62%
X Dodgy tune that is better turned off.
✓ Sound doesn't affect gameplay.

PLAYABILITY 73%
X Never gets exciting to play.
✓ Easy rules and good onscreen prompts.

LORICIEL
£24.99 ● OUT NOW **73%**



DREAM MACHINES



PO BOX 34 HARTLEPOOL CLEVELAND TS27 3YX
 TEL (0429) 231703/869459
 fax: (0429) 869459

SEGA MEGADRIVE

SEGA MEGADRIVE (SCART)£99.95
 SEGA MEGADRIVE (PAL)£105.95
 SEGA MEGADRIVE PAL/SCART
 + FREE MICKEY MOUSE£119.95

CURSE£15.95
 D.J BOY£16.95
 E.S.W.A.T£17.95
 KLAX£17.95
 MEGA PANEL£18.95
 WONDERBOY III£18.95
 CRACKDOWN£19.95
 HELLFIRE£19.95
 DYNAMITE DUKE£19.95
 MICKEY MOUSE£22.95
 MAGICAL HAT£22.95
 MOONWALKER£23.95
 ATOMIC ROBOKID£24.95
 SHADOW DANCER£25.95
 PHANTASY STAR II£25.95
 PHANTASY STAR III£26.95
 GAINGROUND£26.95
 SOKOBAN£26.95
 THUNDERFORCE III£27.45
 SUPER SHINOBI£28.95
 SUPER HANG ON£28.95
 SUPER MONACO£28.95
 RAMBO III£23.95
 AFTERBURNER II£28.95
 COLUMNS£28.95
 ELEMENTAL MASTER£23.95
 HEAVY UNIT£28.95
 SUPER GOLF£28.95
 GAIRES£28.95
 GYNOUGH£28.95
 RINGSIDE ANGEL£28.95
 MONSTER HUNTER£28.95
 DICK TRACEY£28.95
 VOLFIED£28.95
 VERYTEX£28.95
 JOE MONTANA£28.95
 TEL TEL BASEBALL£28.95
 GOLDEN AXE£28.95
 DARWIN 4081£28.95
 TIGER HELI£28.95
 GRANADA X£28.95
 BATMAN£29.95
 DARIUS II£29.95
 KAGEKI£29.95
 BATTLE OF BAIVAGA£29.95
 NADIA£31.95
 ZERO WING£31.95
 JOHN MADDENS£31.95
 MIDNIGHT RESISTANCE£32.95

STORM LORD£32.95
 LAKERS V CELTICS£32.95
 BUDOKAN£32.95
 POPULOUS£32.95
 VARIUS III£33.95
 SUPER AIRWOLF£33.95
 SHINING IN DARKNESS£33.95
 GHOULS N GHOSTS£33.95
 DINO LAND£33.95
 BLUE ALMANAC£34.95
 PACMANIAT.B.A
 POWER DRIFTT.B.A
 OUTRUNT.B.A
 SONIC HEDGEHOGJULY
 G. LOCKAUG
 STORMLORDAUG

FAMICOM

FAMICOM (SCART)£219
 FAMICOM (PAL)£229
 FAMICOM (SCART) + 2 GAMES£269
 FAMICOM (PAL) + 2 GAMES£279

BOMBUZAL£29.95
 GRADIUS III£34.95
 F-ZERO£34.95
 ACT RAZOR£36.95
 PILOT WINGS£37.95
 POPULOUS£37.95
 BIG RUN£38.95
 ULTRA MAN£38.95
 HOLE IN ONE£39.95
 SUPER MARIO WORLD£39.95
 FINAL FIGHT£39.95
 GREAT BATTLE£39.95
 DARIUS TWIN£42.95
 UN SQUADRONT.B.A
 R TYPE IIT.B.A
 SUPER GHOULS & GHOSTST.B.A
 SIM CITYT.B.A

NEO-GEO

NEO GEO£299.95
 RIDING HERO£99.95
 NAM 1975£99.95
 MAGICIAN LORD£99.95
 JOY JOY KID£99.95
 TOP PLAYERS GOLF£99.95

PC ENGINE

PC ENGINE CORE£119.95
 PC ENGINE GT + ANY FREE GAME£239.95

GAME GEAR

GAME GEAR£99.95
 GAME GEAR + 2 GAMES£137.95

WONDERBOY£19.95
 COLUMNS£19.95
 DRAGON CRYSTAL£19.95
 DEVILISH£19.95
 G-LOCK£19.95
 MICKEY MOUSE£19.95
 DENGO£19.95
 POP BREAKER£19.95
 SUPER GOLF£19.95
 CHASE HQ£22.95
 SUPER MONACO£22.95
 PHYSIC WORLD£22.95
 HEAD BUSTER£22.95

GAMEBOY

GREMLINS II£21.95
 F 1 RACE + 4 PLAYER£25.95
 BATMAN£21.95
 KLAX£21.95

HARDWARE

MEGADRIVE JOYPADS£12.95
 TURBO + SLOW MOTION£17.95
 ARCADE POWERSTICK£29.95
 JAP ADAPTERS£11.95
 LIGHT BOY£19.95
 GAMELIGHT£9.95
 MAGNIFIER£8.95
 CARRY CASE£13.95

ALL MACHINES HAVE A FULL 1 YEAR
 GUARANTEE. £5 FOR MACHINES P&P £1
 FOR GAMES £2 FOR HARDWARE

OFFICE HOURS MON-SAT 10AM - 7PM
 SUN 10AM - 5PM

PLEASE MAKE ALL CHEQUES + PO'S
 PAYABLE TO "DREAM MACHINE"

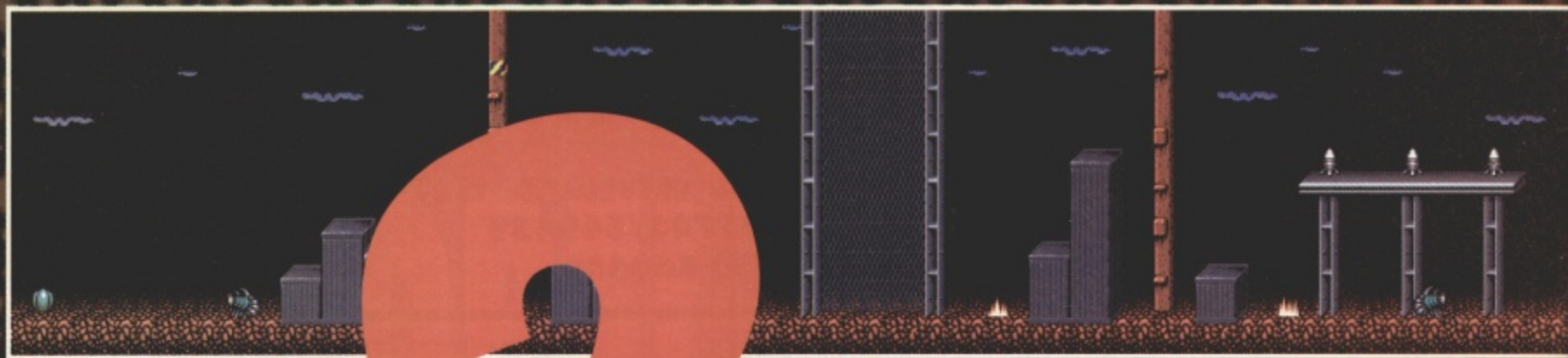

SWITCHBLADE



"Give us back our hero," they cried. So we chucked Les Ellis at them and told them to be grateful

First of all, a quick recap. The original *Switchblade* (released 18 months ago) featured an heroic blade knight called Hiro on a quest to find pieces of a fireblade which were scattered deep in the cyberworld of Thraxx. The fireblade was the ancient source of power for all blade knights, and thus had to be recovered at all costs. The weapon was originally destroyed by an evil dude called Havok, who dispatched his nightmarish minions to stop you in your tracks. But at the end of the day, good triumphed over evil and Havok was



forced to retreat to a volcanic island where he could plan his next nefarious deed.

Now Havok is wreaked upon you once more, and the wicked old man has smashed up the fireblade again (have Thraxxians never heard of SuperGlue?).

You encounter trouble in the underground city. Here a rocket-spitting robot insect fires in totally the wrong direction. You can also see an open doorway. Could this be the way to a part of the fireblade or will it just be more of Havok's misfits?

Whaddya mean you forgot your broolly?

Unfortunately, the original Hiro has left the country of Thraxx in search of fame and fortune in the new land of America (okay, so he's dead). So the people of Thraxx call upon his namesake son Hiro to retrieve the five pieces

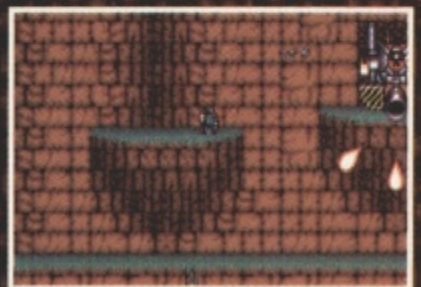

This large gun appears on level two spitting death in all directions. One false step and you could topple over the edge of the cliff.

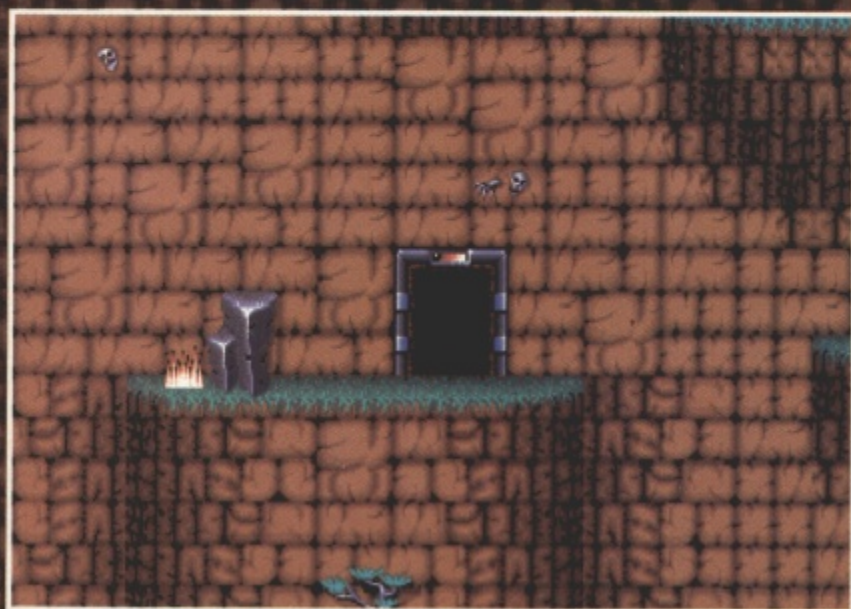
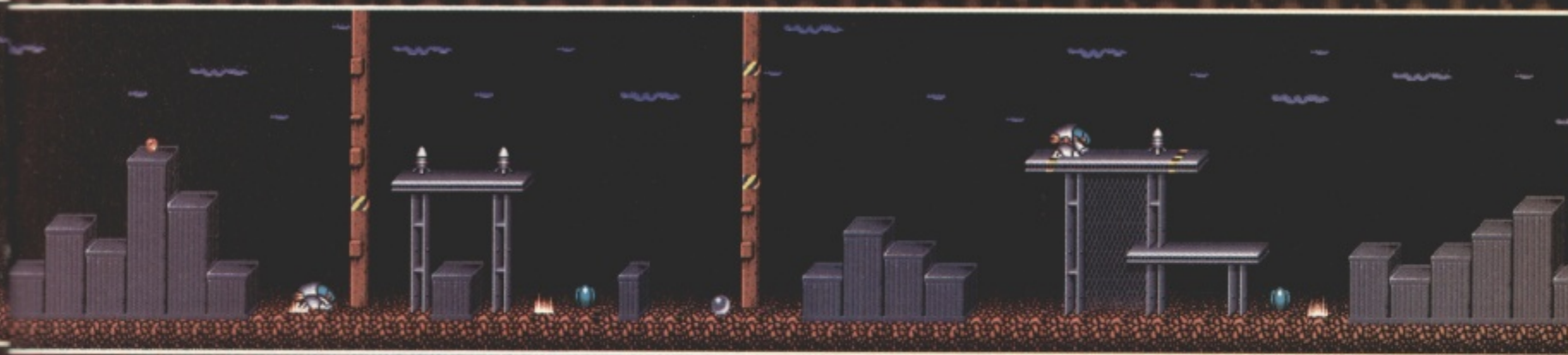

In level two the action moves outside to the cliffs. The doorways lead into the cliff to small rooms which contain helpful icons. Some may have enemies, but all are worth investigating.



of the fireblade.

Hiro's adventure begins in the underground city, with 600 screens of heroic (hiroic?) action lying before him. On leaving the city, you will move out to the cliffs, then up into mountains. From there, you'll trip down to the docks where you can catch a boat which will take you to the volcanic island where Havok practises his wreaking.

Each location holds its own mysteries; sometimes there may be a hidden room, other times it could be a seemingly impenetrable wall which can be sliced through with your sword. But while you are wondering about the solidity of the landscape, Havok's

hordes are, in the best tradition, wreaking havoc on you and your health bar. Your energy can be replenished by either picking up food that is conveniently scattered around the place, or by entering one of the local shops which will be more than happy to sell you some grub in exchange for money you should have picked up.

Switchblade II isn't exactly a

strategy adventure but you will need a good memory and shrewd decision-making if you're to survive the quest. However, to describe it as a platform hack 'n' slash game would be unfair as there's much more to it than the ordinary beat-'em-up fare. If you want a challenge, yet don't have months to spare, then Switchblade II is the ideal game.

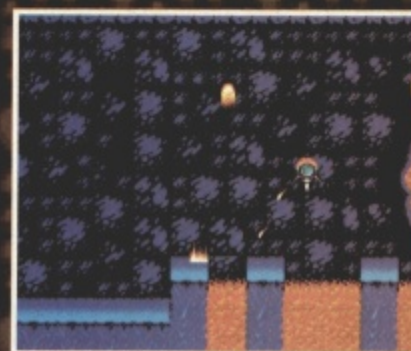

ATARI ST £24.99 ● OUT NOW

GREMLIN

GRAPHICS 89%

- ✓ Wide range of menacing bad guys.
- ✓ Backdrops get better as you progress.

SOUND 63%

- ✗ No in-game music.
- ✓ Ace crunching effects for death.

PLAYABILITY 93%

- ✓ Never stays with one gameplay type.
- ✓ Huge play area, easy to get into.

AMIGA

GREMLIN
£24.99 ● OUT NOW **91%**



CREDITS
80

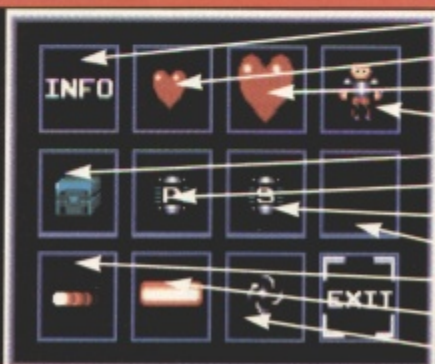

- Info (10 credits) - gives you clues about upcoming levels.
- Half energy (15 credits) - restores half your lost health.
- Full energy (20 credits) - restores all health.
- Extra life (50 credits) - adds a life.
- Full ammo (20 credits) - restores all bullets.
- Power up (20 credits) - increases the strength of weapon.
- Shield (30 credits) - impervious to hits.
- Dragon (40 credits) - acts as an outrider.
- Plasma Gun (10 credits) - the weapon you start with.
- Beam Laser (30 credits) - fires three rays.
- Spin Blades (30 credits) - like nunchukas.

DISC

Frisbee thrower extraordinaire, Julian Boardman discusses the latest offering from through the tunnel

No matter how hard you try, something always gets lost in the translation. In this case it was any last trace of credibility the manual had. It is not just the fact that there are a number of mistakes (even I make mistakes!), it is that they tried to be really clever and put loads of long sentences and colloquialisms into it and they all turn



The tiles at the back are marked with different geometrical shapes to denote the number of hits they require for the corresponding floor tile to disappear. The number of sides on the object indicates the number of hits, from a hexagon down to a circle. Some of the squares will be marked with an infinity sign, this means that they cannot be removed and it is fruitless to hit them. Occasionally a square may be showing a question mark, this will reveal a mystery bonus. The bonuses can be anything from Speed disc to Power disc and may well win you the match.

out wrong. For example, one way to knock off the other guy is to make him fall down a hole, this becomes "By precipitating him in the abyss after leading him to make a mistake," which, frankly, sounds as though you trip him up and then urinate on him as he lies in the gutter. A manual like this does not promise a good game.

Two guys face each other across an abyss on platforms of eight squares; four wide, two deep. Behind each of them is another set of eight vertical squares which correspond to the horizontal tiles. By throwing the disc when it is in your possession, you must try to hit your opponent's vertical tiles. If you hit one often enough it will make its matching horizontal tile disappear, leaving a big



hole in the floor.

Your aim is to hassle your opponent so much that he loses his senses and accidentally jumps through a hole to his death. You can also inflict some grievous bodily harm on him if you happen to hit him with the disc,

Two-player mode would have benefited from a split-screen effect giving each player's personal view, but instead of this the ends are swapped so that each player has the same advantage over the other. To make sure of the fairness of the match, a player has to go two clear matches ahead to win.

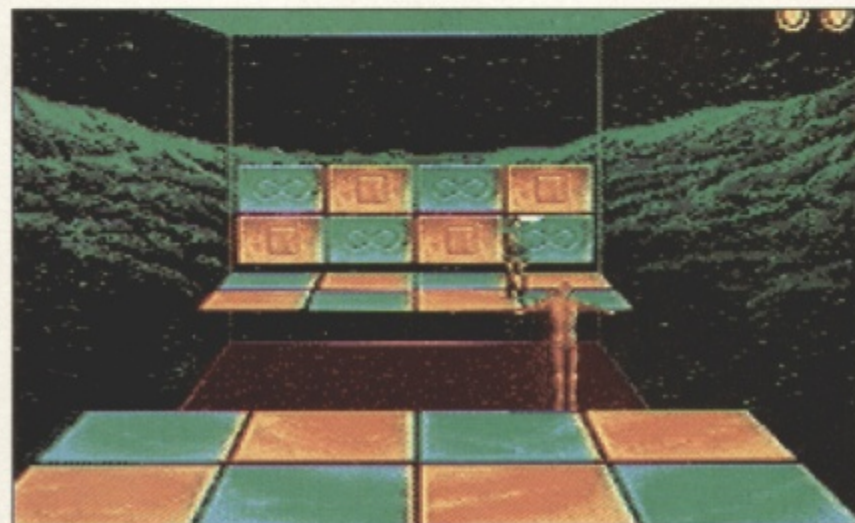

usually by rebounding it off the wall. If you manage to zap all his energy, then this too will bring about his downfall. Either way, the game is about as exciting as throwing a tennis ball against a wall.

Like most "future sports" games (this one is set in the second millenni-



um), you get a motley bunch of degenerates to play against. There's also a tournament option - if you ever feel the need to keep the game loaded for more than five minutes. Above all, I can't help wondering that I've seen this game before. In fact, clearing away the cobwebs from my mind, Disc seems like a mishmash of

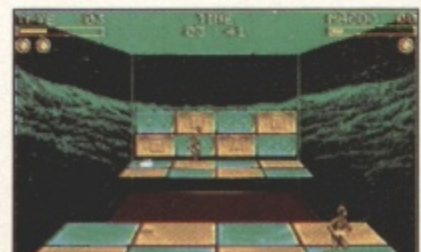

the last stage of *Raid Over Moscow* and the ravine section of *Beach Head II*.

Admittedly, there are some attractive backgrounds and the animation's quite good, but the whole game is just too shallow to warrant a £24.95 price tag. Even in the present budget market, Disc would find itself under attack from far better value games.

AMIGA LORICIEL £24.99 ● OUT NOW

ATARI ST	GRAPHICS 82%
	✓ Smooth animation of clear sprites. ✓ Distinctly futuristic feel.
	SOUND 76%
	✗ Pedestrian tunes. ✓ Imaginative digitised effects.
PLAYABILITY 56%	
✗ Totally uninvolving. ✗ Too repetitive.	
LORICIEL £24.99 ● OUT NOW 59%	

**THE JULY
COMPETITION**

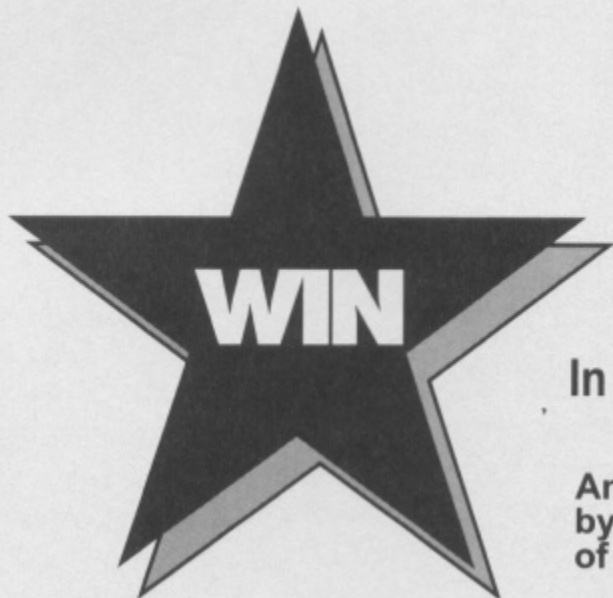

**THE
COMMODORE AMIGA
WIN
SEGA MEGADRIVE
(Plus Game of Your Choice)
WIN
NINTENDO SUPER
FAMICOM
(Plus any TWO Games)
WIN
NINTENDO GAMEBOY**

In The GREAT **DIAL-A QUIZ** MONTHLY Computer
Competition

Answer 4 simple computer related questions correctly and
by this time NEXT MONTH YOU could be the Lucky Winner
of one of the above four Superb First Prizes in this months
DIAL-A-QUIZ Cracking Computer Competition

**You MUST call one of the hotlines below and answer
ALL 4 questions correctly**

And REMEMBER, you can enter ALL Competitions as many
times as you like.

Commodore Amiga Hotline: 0839-121-161

Sega Megadrive Hotline: 0839-121-162

Super Famicom Hotline: 0839-121-163

Nintendo Gameboy Hotline: 0839-121-164

One first prize in each competition. Winners are chosen at random from all correct
entries received. Closing date for entries is 20th July 1991. All calls last approximately
4 minutes and if you are under 18 we ask you to please obtain your
parents consent before dialling.

Calls are charged at 34p per minute cheap rate. 45p per minute at all other times.
If you experience difficulties while attempting to enter please inform us on: 071 485
5964 between 9.30 am & 5.30 pm.

P. Grove. DAIL-A-QUIZ. P.O. BOX 11, SKEGNESS, LINCS. PE25 3NL.

JETFIGHTER II

The most advanced tactical fighter has been loaned to Julian Boardman. Let's hope they don't want it back in the same condition they sent it

The original *JetFighter* was a bit of a corker by all accounts – I never played it – and was acclaimed by several hacks as the best flight sim on a desktop computer. The sequel, therefore, has a load of stuff to live up to.

US Gold have started pretty bravely with the scenario. It is one of those on-going adventures inside the simulation – as opposed to just a flight simulation program – featuring 150 separate, albeit dated, missions.

Communist terrorists have suc-



Free-flight gives ample options to tailor a particular practice scenario to your taste. You can decide where to take off, where to land, how many bandits you want to shoot down, even what time of day it is.

TIME FOR DINNER (MAN)

Bob Dinnerman has been on a personal crusade to create the most realistic, affordable flight simulation since he designed the coin-op *Discs of Tron* for Bally. To get where he wanted, he launched his own company, RD Technologies, and created the highly popular and critically acclaimed *F/A-18 Interceptor* for the Amiga and *JetFighter* for the IBM PC. It is to this noble and selfless end that he has produced *JetFighter II*. (Translation of packaging blurb ©1991 Julian Boardman.)

cessfully invaded California (hey, if you're going to invade somewhere, make it hot), and it is your job to fly missions into the mainland from the carrier USS Constellation, in the hope of defeating the Commies. These missions start off fairly easily, picking off single rookie jets and the like, but by the time you get up to mission 150 we are talking multi-role interdiction, with the balance of power lying in your sweaty hands.

You get a choice of four planes

The game can be played in three ways: the adventure, which is the full campaign to recapture California; combat, which is the chance to play one mission but it does affect your combat rating, and free-flight, which doesn't, but does give you the chance to practise take-off and landing.

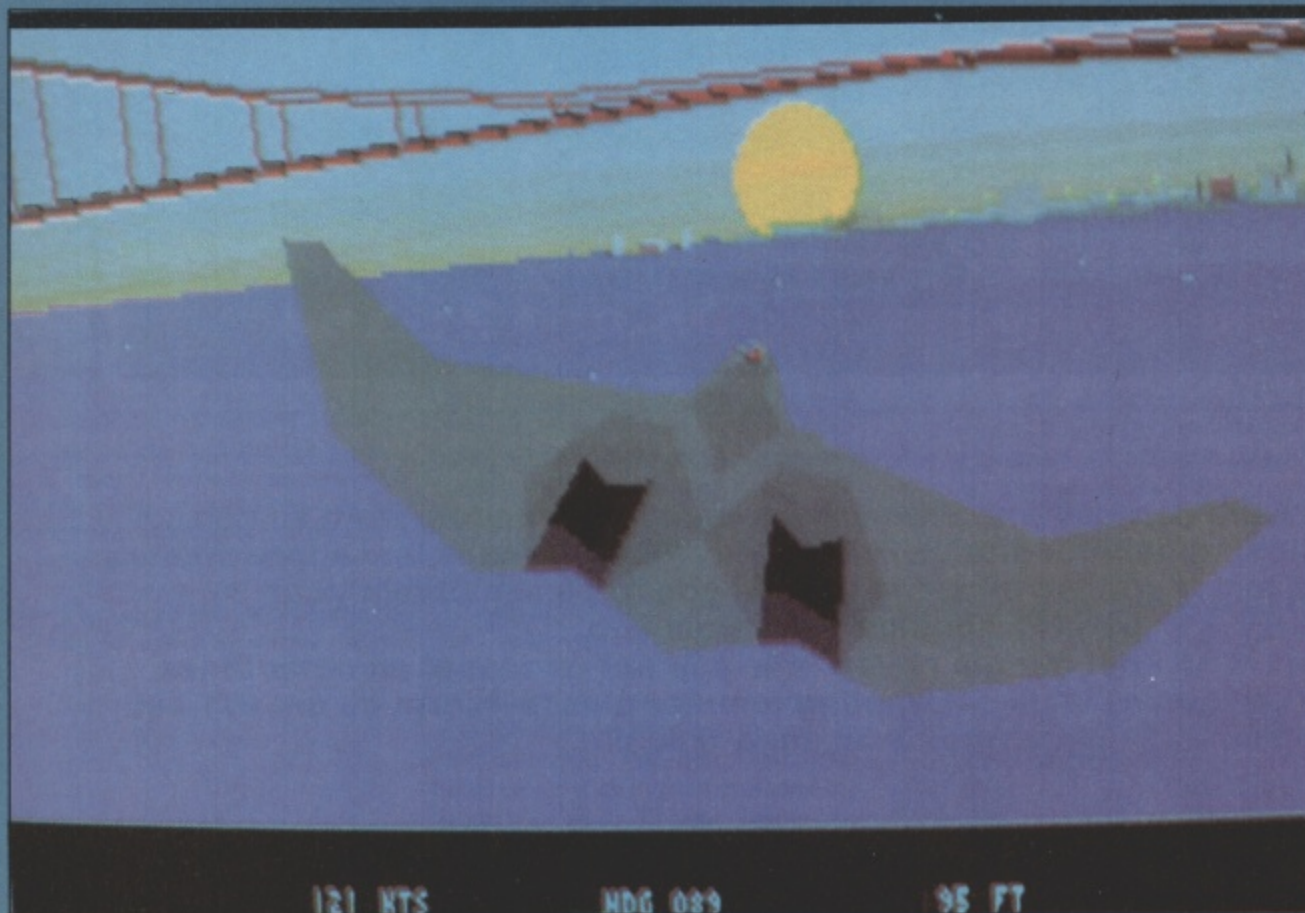

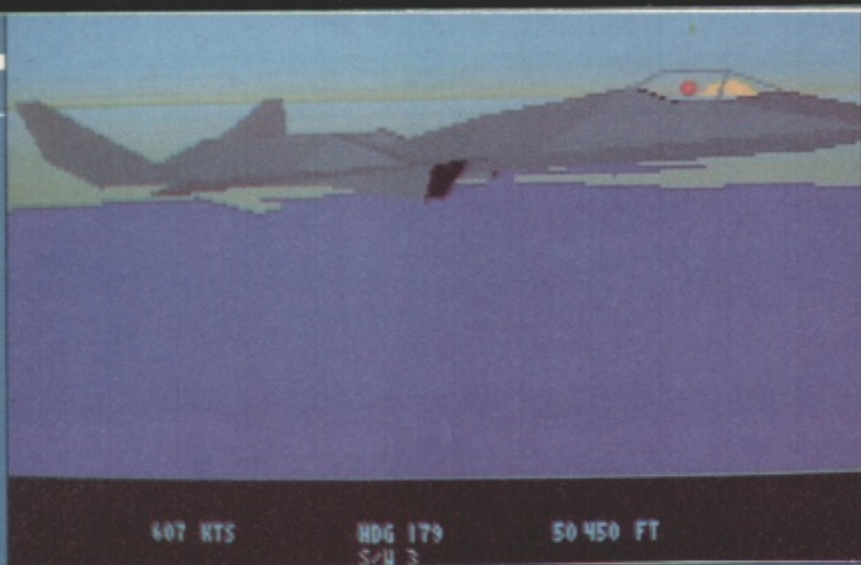

and animated landing gear retraction.

But don't balk at all this technology. Should you be what is known as "a crap pilot" then all is not lost. There is a free-flight trainer that just sticks you up in the air

What you get with *JetFighter II* is a very professional, and impressively constructed package. The graphics are fantastic, helping the feel of the game, and the sound from an AdLib card is booming enough to ruffle your hair.



to pilot: the F/A 18 Hornet, F-16 Falcon, F-14 Tomcat and F-23. The F-23 is apparently the most deadly aircraft ever built, blending radar stealth with the latest self-guiding, cup-of-tea-making weapons – and all at speeds of up to Mach 3. Each plane has its own separate cockpit configuration and HUD

through which you can view the beautifully shaded, light-sourced, dithered and thithered horizon and landscape (of course CGA mode doesn't quite convey that impression). The 3-D driver is one of the fastest I have seen and also includes features like animated explosions, opening parachutes

and allows you to come to grips with the planes without affecting your rating in the combat adventure. It also gives you a chance to practise landing, as there is no autopilot. A newcomer to flight sims should spend at least six weeks practising the landing procedure. Believe me, anybody who is not familiar with Electronic Arts' *F/A-18 Interceptor*, written for the Amiga by the same guy who did this, will have big trouble trying to land this multi-million dollar air-

However, I am still left wondering if flying into California is really enough excitement to last for 150 missions – even if the aim is to release it from the stranglehold of the Communists. There is nothing in the gameplay to make it stand out from other flight sims, it is neither better nor worse than any other. However, the graphics really do warrant a viewing. After all, if you're going to get a flight simulation, you may as well get one with great graphics.

RED YAWN RISING

The idea of the USA being invaded by the Communists has been around since the paranoid days of McCarthy's Commie witch-hunts of the late Forties and Fifties. Movie-makers were quick to pick up on the drama and feed on the very real fears, at the time, of just such an invasion. So **RAZE** is happy to present the filmography of the movies that represented and heightened the nightmares of a generation.

The Red Menace (1949, dir: RG Springsteen) Robert Rockwell stars as a war veteran who is duped by the Communists. Unintentionally funny McCarthyesque propaganda. **Invasion USA** (1952, dir: Alfred E Green) Fully-fledged invasion by "The Enemy" that never actually mentions Communism, but you know who "They" are. Relies on too much stock battle footage to be of any value.

The Russians are Coming! The Russians are Coming! (1966, dir: Norman Jewison) Popular, but at the time overrated, comedy about a Russian submarine that lands off the New England coast. Good comedy by Alan Arkin in his first starring film role.

Telefon (1977, dir: Don Siegel)

Charles Bronson stars as a Russian agent sent to stop a crazy defector from triggering hypnotised sleepers to cause havoc in the US. Lee Remick, Donald Pleasance and Tyne Daly assist in this slick thriller.

World War III (1982, dir: David Greene) Robert L Joseph's thriller transferred to the small screen stars Rock Hudson as US President on whose decision a possible nuclear holocaust rests. The Russians are invading Alaska and David Soul is sent to investigate.

Red Dawn (1984, dir: John Milius) Patrick Swayze, Charlie Sheen and C Thomas Howell pick up early roles in this pretentious and overly violent tale of how small-town teens become guerillas after the Russians invade.

Invasion USA (1985, dir: Joseph Zito) Chuck Norris stars in this gratuitously violent yarn about Russian terrorists landing in Florida. Avoid.

Russkies (1987, dir: Rick Rosenthal) Well-meaning but uninspired reworking of *The Russians Are Coming! The Russians Are Coming!* about a Russian sailor washed ashore in Florida and the three youngsters who befriend him. Leaf Phoenix (brother of River) helps deliver a message of fellowship.



craft on a carrier that seems to be the size of a postage stamp. You do get the state-of-the-art HUD landing assistance to guide you in but it is still not one of the easiest tasks you could wish for.

GRAPHICS **92%**
 ✓ Real-time night and day.
 ✓ Fully flexible camera angles and zoom.

SOUND **78%**
 X Audio feedback could be improved.
 ✓ Supports AdLib for some huge effects.

PLAYABILITY **79%**
 X Realism sometimes gets in the way.
 ✓ Huge number of missions and options.

IBM PC

VELOCITY/US GOLD **85%**
 £39.99 • OUT NOW

AMIGA

VELOCITY/US GOLD
 ETBA • SPRING 1992

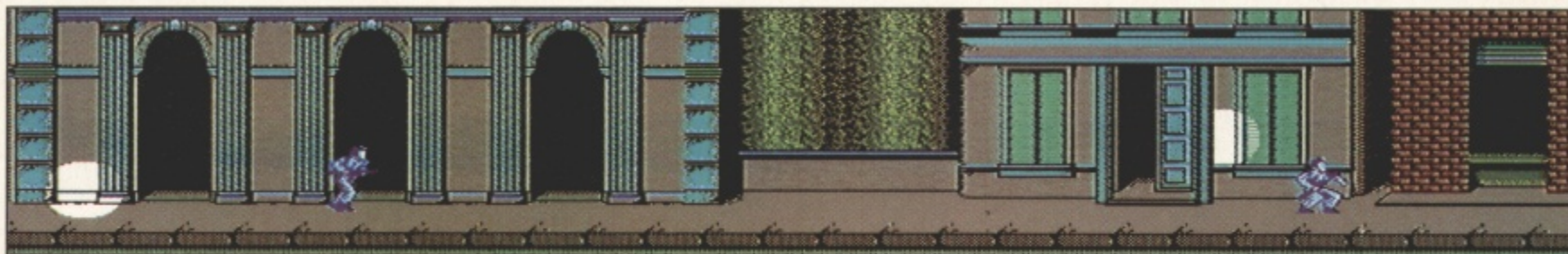

RESCUE

THE EMBASSY MISSION

Les Ellis interrupts the snooker to bring you an urgent news-flash

In America, people say, where were you when you heard of Kennedy's assassination? But in Britain, people ask each other, where were you when you saw the SAS assault on the Iranian embassy in London? Of course, most of us were at home watching the World Snooker Final.

If the world of black balaclavas and smoke bombs is for you, then this covert offering from Nintendo should provide an interesting challenge. But *Rescue* isn't a brand-new concept, the game is a new guise for Infogrames' old game *Hostages* — which was very favourably received in 1988.

The scenario is an all too familiar one. A foreign embassy has been taken over by a ruthless band of terrorists. By threatening the lives of the 14 hostages, they hope to free terrorist prisoners from all over the world. But their demands are totally unreasonable, and after 11 days of intense negotiation in the hope of reaching a peaceful settlement, it has been decided that there is only one course

Your first task is to place three snipers, Mike, Steve and Jumbo, at strategic points around the embassy. Unfortunately, the terrorists have commandeered the embassy's

straight in the top floor of the embassy.

Either way the aerial crew, Ron, Dick and Kemco (!), will have to rapell (abseil) down walls of the building and each smash through one of the windows. The aerial crew now become your rescue crew as they scour the three floors of the embassy in search of the ambassador and the other 13 hostages. As in a shooting gallery, both good and bad guys will pop out of doors into the corridors, so you must be totally sure of your target before you blow it away. The mission is only totally successful when all of the hostages are rescued and every one of your team

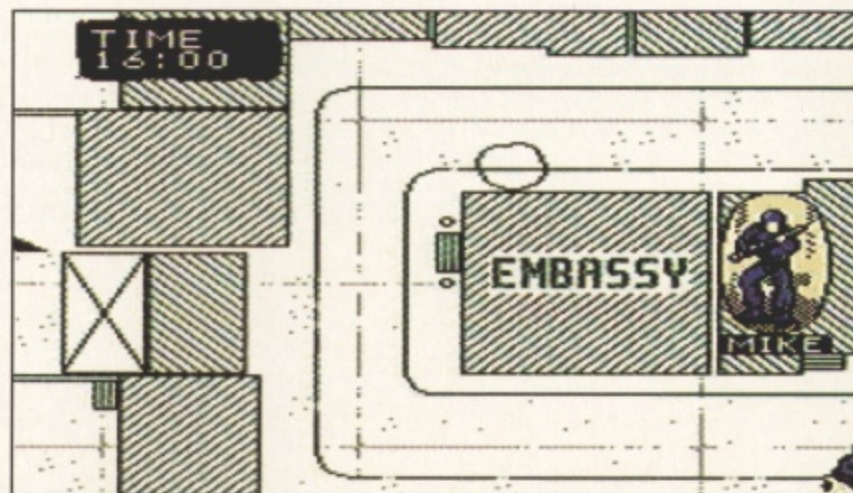
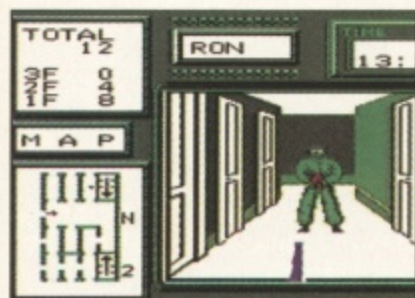

search lights, so the approach involves much ducking, diving and somersaulting.

Once your three amigos are in position, you can give the order for the aerial assault on the building.

has returned.

There are three levels of difficulty, with five missions in each. Each mission has a different time limit, and as the difficulty level increases so does the speed of the enemy and search lights.

It makes a welcome change from arcade adventures and shoot-'em-ups to receive an original, albeit converted, game on the Nintendo. The whole look and feel of the game is very fresh and inviting, with graphics that would shame most other NES and Master System games.



of action left. A memo is sent to a top secret base informing you, Lieutenant Colonel John R Clarke of the US Special Forces division, that your team of crack undercover problem-solvers has been called in to help.

Depending on what time you have left on the clock, and how many snipers survived the first assault, you can choose whether to use the snipers to knock out the terrorists appearing near the windows of the embassy or send the rooftop crew

GRAPHICS	93%
✓ Very detailed on all parts of the game.	
✓ Some of the best NES graphics ever.	
SOUND	87%
✓ Atmospheric music throughout.	
✓ Rattling good shooting effects.	
PLAYABILITY	86%
✓ Three very different styles of play.	
✓ Higher levels are a real challenge.	
NES	KEMCO
£24.99	OUT NOW
	87%

PC Engine SUPPLIES

(MAIL ORDER)
PC Engine Supplies
 223B Waterloo Road
 Cobridge S-O-T
 Staffs ST6 2HS
 (Registered Office)

(SHOP & MAIL ORDER)
Console Concepts
 The Village
 Newcastle-U-Lyme
 Staffs ST5 1QB

Telephone 0782 712 759 (9.00am TO 6.30pm)

0782 213993 (6.00pm to 7.30pm) (Orders only)



All enquiries daytime number only. Trade enquiries welcome.
 Access and Visa now accepted VAT No. 536 8202 45. Fax No. 0782 208429



NINTENDO GAMEBOY

NINTENDO GAMEBOY JAPANESE CARTRIDGES ALL £20 & P+P
 NINJA TURTLES
 BATMAN
 DOUBLE DRAGON
 CHASE HQ
 GREMLINS II
 HEAD ON
 KARATE BOY
 BOULDERDASH
 1 MAN AND HIS BLOB
 PACMAN
 DUCK TALES
 CONTRA II
 F1 SPIRIT
 FINAL REVERSE
 NEMESIS
 ALLEYWAY
 PINBALL PARTY
 SPACE INVADERS
 PENGUIN WARS
 PENGUIN LAND
 R TYPE
 TETRIS
 NAVY BLUE 90
 BLODIA
 CASMIC TANK
 PIPE DREAM
 PC FROG
 LUNAR LANDER
 AFTERBURST

ALL USA CARTS BELOW £25.00 & P+P

NINJA TURTLES
 BATMAN
 DOUBLE DRAGON
 FINAL FANTASY
 ROBOCOP
 CHASE HQ
 GHOSTBUSTERS II
 POWER CHASE
 PAPERBOY
 SKATE OR DIE
 R TYPE
 KUNG FU MASTER
 DRAGONS LAIR

NINTENDO SUPER FAMICOM INCS:-
 SUPER FAMICOM (TV OR SCART, 2 JOYPADS, ANY 2 GAMES FREE!)
 £290.00 & £6 P+P

Nintendo SUPER FAMICOM JAPANESE CARTS

ALL BELOW £40 & P+P

SUPER MARIOWORLD
 F-ZERO
 FINAL FIGHT
 GRADIUS III
 PILOT WINGS
 POPULOUR
 SUPER DEFORMER
 BOMBOOZAL
 ACTRAISER (UK INSTRUCTIONS)

CALL FOR BEST PRICE FOR TITLES BELOW:-

SIM CITY
 GHOULS AND GHOSTS
 POWERMONGER
 HOLE IN 1 GOLF
 KICK OFF II
 BIG RUN
 R TYPE II
 ULTRA MAN
 SUPER DARIUS

PC ENGINE

JAPANESE CARTS ALL £30 & P+P

OUTRUN
 TAITO WRESTLING
 OVERRIDE
 VIOLENT SOLDIER
 HURRICANE (1943)
 BURNING ANGELS
 SAINT DRAGON
 THUNDERBLADE
 DARIUS PLUS
 KLAX
 PC KID
 W-WING
 DIE HARD
 AFTERBURNER II
 LEG AXE II
 AERO BLASTER
 POPULOUS
 MOTORADER II
 IMAGE FIGHT
 RABID LEPUS
 AFTERBURNER III
 DON DOKO DON
 FINAL BLASTER
 GOMOLA SPEED
 OP WOLF
 POWERDRIFT
 VIOLENT SOLDIER
 CADASH
 YS BOOK 1+ 2 (CD) £39
 SCI (CHASE HQ!!)
 JACKIE CHAN
 IT CAME FROM THE DESERT (CD)
 HELLFIRE (CD)
 RAINBOW ISLAND (CD) £39
 1943
 BUBBLE BOBBLE II
 (PARASOL STARS)
 ZERO 4 CHAMP (RACING)
 DEADMOON
 ALL DYNES (S GRAFX)
 TV SPORTS FOOTBALL
 LEGEND OF TONMA



SEGA MEGADRIVE PACK 1:-
 INC MEGADRIVE (TV OR SCART)
 JOYPAD, INFRA RED JOYSTICK +
 FREE GAME OF YOUR CHOICE
 UPTO £30 = £160 +P+P

SEGA MEGADRIVE PACK 2:-
 INCS MEGADRIVE (TV OR SCART)
 JOYPAD + FREE GAME OF YOUR
 CHOICE UPTO £30 = £130.00 + P+P

NINTENDO 8 BIT (NES).

ALL BELOW FIT UK MACHINE.

GUNSMOKE 24.00
 STEALTH ATF 29.00
 PRADIKUS CONFLICT 34.00
 IMPOSSIBLE MISSION 39.00
 BLACK MANTA 29.00
 KING NEPTUNE 34.00
 PINBOT 29.00
 TETRIS 24.00
 SPY VS SPY 19.00
 SILENT ASSAULT 34.00
 SNAKE RATTLE AND ROLL 24.00
 DONKEY KONG 19.00

MANY MORE TITLES AVAILABLE.

PRICES SLAUGHTERED SEGA MEGADRIVE MADNESS

ANY GAME FROM THIS LIST
 £25.00 OR 5 FOR £100 & P+P £5.00

(Please list alternative choices)

AXIS
 DANGEROUS SEED
 ALTERED BEAST
 E SWAT
 HARD DRIVIN
 GRANADA X
 SHADOW DANCER
 ARROWFLASH
 DJ BOY
 ATOMIC ROBOKID
 FATMAN
 ELEMENTAL MASTER
 RING SIDE ANGEL
 ZANY GOLF
 MUSA ALESTE
 CRACKDOWN
 BURNING FORCE
 SWORD OF SODAN

SEGA MEGA DRIVE

JAPANESE CARTS ALL BELOW £30.00 & P+P

HELLFIRE
 MOONWALKER
 RASTAN SAGA II
 DYNAMITE DUKE
 GAIRES
 DARIUS III
 FIRE SHARK
 WONDERBOY III
 AERO BLASTER
 POWER BALL
 DICK TRACY
 INSECTOR X
 BASKETBALL
 COLUMNS
 GHOSTBUSTERS
 VOLFIELD
 HEAVY UNIT
 MICKEY MOUSE
 MAGICAL HAT
 KAGEKI
 VOLLEYBALL
 AMBITIONS OF CAESAR
 KYUKYOKU TIGER
 SUPER AIRWOLF
 BATTLE GOLFER
 GYNOOG
 WRESTLE BALL
 FANTASY SOLDIER III
 MIDNIGHT RESISTANCE
 SHINING IN DARKNESS

USA/UK CARTS BELOW £38.00 & P+P

LAKER V CELTICS
 BUDOKAN
 SWORD OF SODAN
 STRIDER
 JOE MONTANA
 BRAIN RUN
 A PALMER GOLF
 POPULOUS
 MANAGO GP
 JOHN MADDON
 SONIC HEDGEHOG
 STORMLORD

JAPANESE CART CONVERTOR £14.00

ACCESSORIES

MEGADRIVE
 CARRYCASE £30
 INFRA RED STICK £35
 PRO 1 STICK £30
 UK/JAP CONVERTOR £14
 8 BIT CONVERTOR £30
 JOYPAD £15
 JAP MAG £7
 ARCADE POWERSTICK £40

GAMEBOY
 CARRY CASE £15
 CONSOLE DELUXE £69
 CASE BOY £20
 LIGHT BOY £20
 GAMLIGHT £14

STEREO ADAPTOR BATTERY PACK CALL CALL

NINTENDO 8 BIT (NES) USA IMPORTS

PLEASE NOTE THE FOLLOWING CARTRIDGES ONLY WORK IN USA CONVERTED CONSOLES

CYBERNOID	34.00
HEAVY BARREL	34.00
OP WOLF	34.00
IRON SWORD	39.00
MARIO III	45.00
BACK TO THE FUTURE 2	CALL
A BOY AND HIS BLOB	CALL
CALIFORNIA GAMES	CALL
CONTRA	CALL
DOUBLE DRAGON III	CALL
DUCK TALES	CALL
IKARI WARRIORS II	CALL
JACKIE CHAN	CALL
MANIAC MANSION	CALL
NARC	CALL
MEGAMAN III	CALL
THE SIMPSONS	CALL

TO RUN THE USA CARTS SEND YOUR MACHINE TO US FOR MODIFICATION £26.00 INC RETURN P+P. IT WILL THEN RUN ALL USA CARTS + ALSO ALL UK CARTS NOW FULLY COMPUTERISED ORDERING SYSTEMS 3 LINES.

BEWARE OF IMITATORS

We are one of the largest importers of Japanese consoles/games in the UK. We will still be here when others disappear.

PC ENGINE (PAL OR SCART) + 1 FREE GAME OF YOUR CHOICE £165.00 & P+P

Same day despatch on all VISA/ACCESS/POSTAL ORDERS subject to availability. (call 0782 712759). All our consoles carry 12 months guarantee. Please add £5.00 P+P for consoles £1.00 P+P for each game title rapid despatch 24hr parcel force + Royal Mail.

WE RESERVE THE RIGHT TO CHANGE PRICES WITHOUT NOTIFICATION SEGA/NINTENDO/NEC FAMICOM ARE TRADEMARKS OF THEIR RESPECTIVE OWNERS.

NOW A FULLY COMPUTERISED ORDERING SYSTEM - 3 LINES

VOUCHER/ORDER FORM CUSTOMER ACCOUNT NO.

PLEASE TICK HERE TO BE PUT ON MAILING LIST

NAME
 ADDRESS

I enclose cheque/PO for £
 or charge Access/Visa No:

Expiry Date / / Signature

PLEASE RETURN TO: PC ENGINE SUPPLIES, 223B WATERLOO ROAD, COBRIDGE, STOKE-ON-TRENT, STAFFS ST6 2HS.

★ ★ ★ YOU'VE TRIED THE REST!! NOW TRY THE BEST ★ ★ ★

HEAVYWEIGHT champ



Jools, RAZE's own heavyweight champ, refused to be the butt of any more weight jokes, so it was left to the super light featherweight Les Ellis to slug it out with Buster Douglas

KINGS OF THE RING

"Gritty" Bob Santana – the easiest of the lot; hit him hard and fast and he won't last long.

Tom "Bulldog" White – strong and fast, favours body punches; use combinations to beat him.

Mike "Spunky" Williams – moves fast, doesn't hit too hard and can take a lot of punishment.

Robert "The Crusher" Bernard – has the power of three normal boxers, but is vulnerable to body punches.

Keith "The Man" Gibson – undefeated champion, excels in all areas.

Boxers are a strange breed. What sane person would jump into a ring knowing that they're going to get their brain pulped? But fame and glory does

take your hat off to lovable Frank – I mean, who else could turn from boxing brute into pantomime fairy? Boxers, eh, a law unto themselves. In the latest game to bash its way

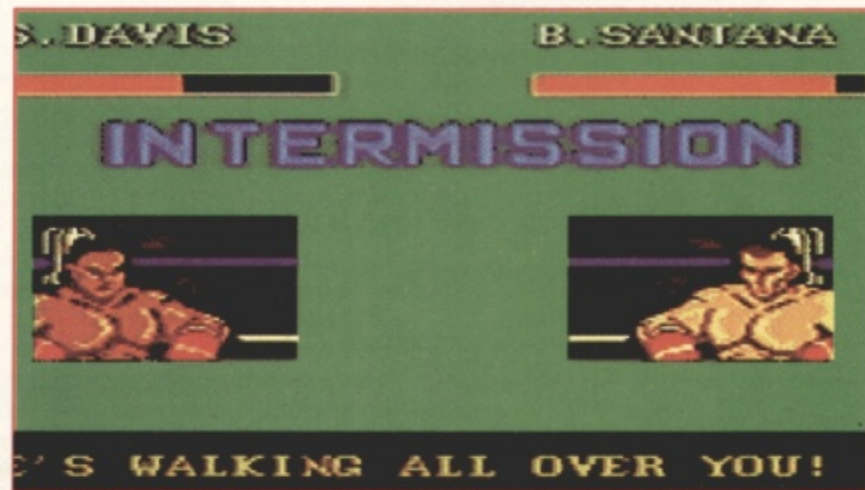

bring immense fortunes, even if they lose (remember Bruno?). In fact losing is becoming something of a British art, with Gary Mason and Nigel Benn following in Frank's large footsteps and gaining recognition from classic defeats. But you must

Between rounds you get an intermission screen. If your fighter is breathing heavily then he's going to struggle, if he's breathing normally he'll probably survive any major onslaught – the same goes for your opponent. If it looks like things could get tricky, turn to your corner man for a bit of advice (although sometimes it's not very helpful).



M'lawds, ladies and gentlemen, in the blue corner we have the reigning champ. While in the red corner is the challenger, Lesley "Bomber (Man)" Ellis.

onto the Sega, you guide a young fighter called "Stingin" Steve Davis from gutter street fights to a world championship fight. Five boxers stand between you and the heavyweight crown (see Kings of the Ring). One of this motley crew can be played by a "friend", although they are all normally controlled via computer.

The ring is viewed side-on, with both boxers coming out of their respective corners to start the bout.



Everything is pretty much as standard boxing – punch, punch, block, punch – until out of the blue you get hit by an indefensible punch that sends you reeling across the ring and smashing into the ropes. I forgot to mention that every boxer comes equipped with three of his own "special" punches. The only way to avoid one of these smashers is to dodge and duck your way around it. Luckily, you'll see the computer's power meter build up when he's going for one, so you are usually prepared for it.

Easy to get into, with a two-player option as well, *Heavyweight Champ* weighs in at £25. Can you overcome the odds and become World Champ?

MASTER SYSTEM	GRAPHICS	78%
	✓ Atmospheric little characters ringside.	
	✓ Watch and cringe as the punches land.	
	SOUND	35%
	X No music to speak of.	
X Ditto with spot effects.		
PLAYABILITY	67%	
X Only FIVE opponents!		
✓ Dead easy to pick up and play.		
SEGA		65%
£24.99 • OUT NOW		

MEGADRIVE + FAMICOM

FROM
SHAFTWARE LTD

MEGADRIVE: Latest Japanese model. Runs all cartridges. English instructions. Includes ANY game. **£149.99**

FAMICOM: Phone for latest prices and deals

ALL THE LATEST GAMES ARE AVAILABLE FOR MEGADRIVE, FAMICOM, GAMEGEAR, GAMEBOY AND PC ENGINE

SPECIAL OFFERS: Mickey Mouse £24; Strider £32; ESWAT £26; Hellfire £26; Thunderforce III £32; Magical Hat £28; Moonwalker £28

FREE £5 GAMES VOUCHER WITH ALL CONSOLES SOLD!

CALL US ANYTIME
(MON-SUN) ON:
081 763 0437

ALL ORDERS
DESPATCHED SAME DAY
SUBJECT TO
AVAILABILITY. P+P - £1
GAMES, £5 CONSOLES

SHAFTWARE LTD,
27 SMITHAMDOWN
ROAD, PURLEY,
SURREY, CR8 4NG

GAMES GALORE

GAMEBOY SOFTWARE: THE BEST PRICES IN THE UK

97 KINGLEY ROAD, HOUNSLOW, MIDDLESEX TW3 4AH
TEL 081 572 0990 FAX 081 577 0969

£18.99

BOXXLE / FUPPUL / CAT TRAP / LOOPZ /
BURAI FIGHTER / PIPEDREAM / LOCK N
CHASE / BUBBLE GHOST / BOOMERS
ADVENTURE

£18.99

£19.99

DEAD HEAT SCRAMBLE / SERPENT / FIST
OF NORTHSTAR / CHESSMASTER /
KUNG FU MASTER / BASES LOADED /
SHANGHAI / ISHIDO / DOUBLE DRAGON

£19.99

£20.99

PAPERBOY / ROBOCOP / CHASE HQ/
TURTLES / HAL WRESTLING / BATMAN /
CYRAID / SKATE OR DIE / NFL FOOTBALL
/ GREMLINS 2

£20.99

ALL SOFTWARE TITLES HAVE ENGLISH INSTRUCTIONS:

Name:..... Titles:.....

Address:.....

Card No

Postage & Packing £1.00 per title.....

(This advert is worth 50p off any title on your next order).

TREASURE ISLAND

1 2 3 4 5 6 7 8 9 10

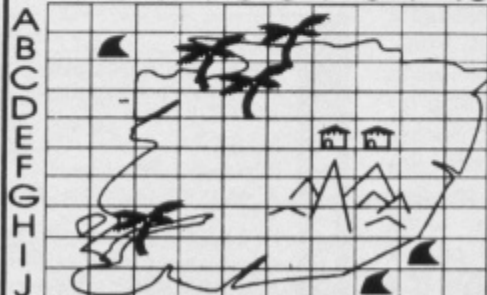

0898 313 586

Infodial PO Box 36 LS1 4TN Call charges 34p per min Cheap rate 45p all other times

TELEGAMES

(0533) 880445/813606/889989
FAX 0533 - 813437

We stock games and cartridges
for all of the following -

EUROPE'S
LARGEST STOCK
OF VIDEO GAMES

CBS VICTOR

WHY WAIT?
ORDER NOW !!!
FAST DELIVERY.

Intellivision

ATARI

Nintendo

GAME GEAR
HANDHELD

LYNX
2600
and
7800

SEGA
MEGA DRIVE

NINTENDO
GAMEBOY

PC
Engine

PCGT
HANDHELD

SEGA

SNK
Neo-Geo

PC SUPER
GRAFIX

Nintendo
SUPER FAMICOM

NEW FOR NINTENDO



'WHAT VIDEO GAME' 2 HOUR VHS FILM SHOWS
OVER 400 GAMES FOR MOST SYSTEMS SPECIAL
PRICE £7.95 plus 2.00 P+P

IF ITS
AVAILABLE
WE
STOCK
IT !!!

ESTABLISHED
FOR OVER
14 YEARS

* FOR FULL DETAILS SEND
LARGE SAE TO -
TELEGAMES
KILBY BRIDGE, WIGSTON, LEIC'S LE8 1TE

The Leading Video Game - Specialists.

World Class LEADERBOARD

Les Ellis, the oldest swinger in town, gets out those plaid trousers again

Golf games are a bit of an oddity on consoles. The irony is that most of the people who vehemently defend their existence would be the last people to spend a Sunday afternoon actually traipsing around a *real* golf course, hitting *real* golf balls. Still,

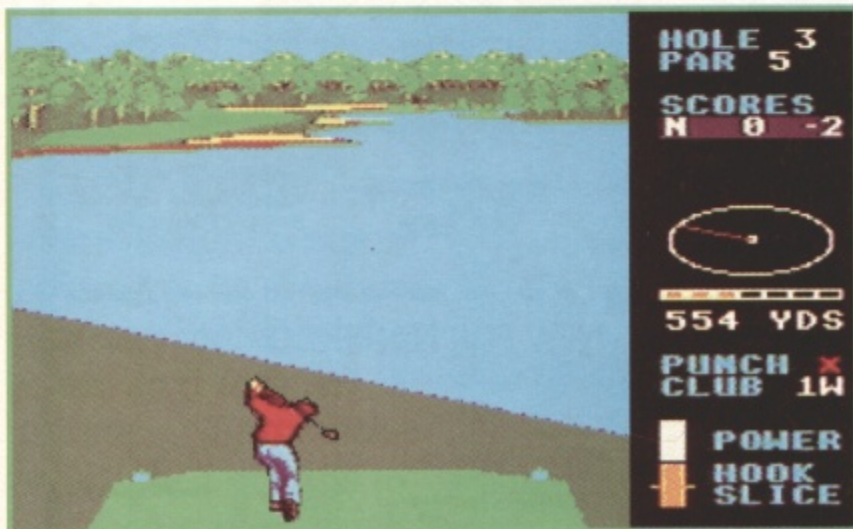

Cough, wheeze, pant. After travelling what seems thousands of yards, you begin to wish that this course had provided courtesy buggies. However, a simple chip shot should put you onto the green with a simple putt to sink for the hole.

Cyprus Creek. The last course is specifically designed for *World Class* and combines all the toughest elements of the world's courses with the finest greens and longest fairways that any golfer could hope for.

Up to four players can compete in a stroke play tournament: ie, the player who takes the least shots to complete the 18 holes is the winner. There are three levels of difficulty, and a practice range where you can hone your putting and driving skills.

All said and done this is a perfect translation of the original *World Class Leaderboard* – as far as I can remember the old stalwart. In comparison, *Golfmania* is purely a simple arcade game. For a real challenge, settle for the original and best golfing series from Access/US Gold.

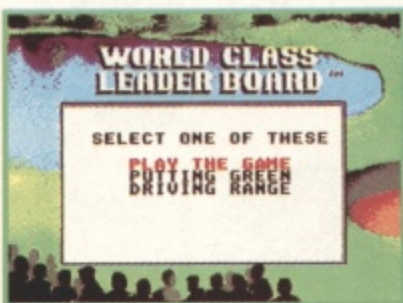

that's electronic entertainment for you: if it involves any effort then the console equivalent will take all that out of it. Indeed, we, the public, devoured the computer versions of the *Leaderboard* series with relish. Never before could anyone know so much about the sport without actually setting foot on a course.

It comes as quite a surprise that we should have to wait till now to get a *Leaderboard* version on the Master System; the version was originally planned a year ago. Meanwhile, games such as *Golfmania* have



provided a steady diet, but none have entirely satisfied the appetite of Master System golfers.

World Class Leaderboard is no different in play from the original *Leaderboard*. However, it does contain some extras and improvements over the original. For a start, the graphics are enhanced, featuring complex reconstructions of trees, bushes, lakes and even sand bunkers. The game itself is also far larger than *Leaderboard*, containing four courses. The first three are accurate representations of real courses from around the world (although the RAZE travel budget won't allow me to verify this): the world famous St Andrew's, Florida's Blue Monster at the Doral Country Club and the massive course of

If it's cool and trendy clothes you're after, then look elsewhere. Even when *World Class Leaderboard* originally came out over three years ago, the clothes were still out of date. Will these golfers ever take notice of what "real" people are wearing? I mean, you win hundreds of thousands of pounds putting a little ball down a hole and then spend the money on tartan trousers!

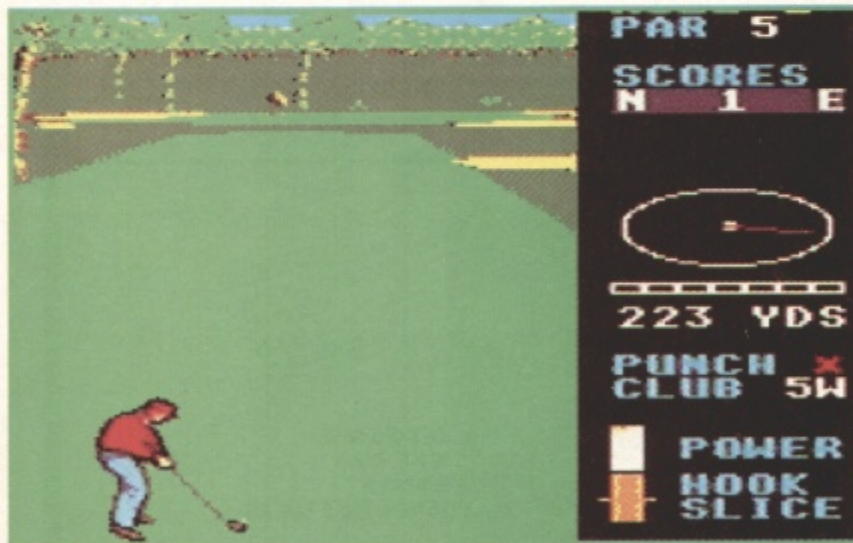

MASTER SYSTEM	GRAPHICS	80%
	✓ World class swinging animation. ✓ Heavy detail on the courses.	
	SOUND	85%
	✓ Outstanding digitised speech. ✓ Neat title music and realistic effects.	
	PLAYABILITY	85%
		✓ Tough enough for seasoned golfers. ✓ Compulsive action in multi-player mode.
ACCESS/US GOLD		84%
£29.99 ● OUT NOW		

S.G.M.

Solid Gold Marketing

UNIT 6 LOMOND TRADE CENTRE
LOMOND INDUSTRIAL ESTATE
ALEXANDRIA DUNBARTONSHIRE
SCOTLAND G83 0TL

TEL:0389 55973
FAX:0389 55942

SUPER FAMICOM SUPER DEAL SAVE £75.70p



**OUR SUPER DEAL PRICE
FOR THIS PACKAGE
£489.95 + £10.00 p+p**

WITH THESE 7 GAMES:

	<u>REGULAR PRICE</u>
SUPER MARIO WORLD	£43.95
HOLE IN ONE GOLF	£47.95
BIG RUN	£47.95
FINAL FIGHT	£43.95
F-ZERO	£43.95
ASTRO LASER	£43.95
PILOT WINGS	£43.95
SUPER FAMICOM	£250.00
REGULAR TOTAL.....	£565.65

SUPER FAMICOM + 2 GAMES.....£290.00 + £10.00 P+P

SOFTWARE AVAILABLE

SUPER MARIO WORLD	£43.95	HOLE IN ONE GOLF	£47.95
BIG RUN.....	£47.95	FINAL FIGHT	£43.95
F-ZERO.....	£43.95	ASTROLASER	£43.95
PILOT WINGS	£43.95	POPULOUS.....	£45.95
GRADIUS III	£43.95	BOMBUZAL	£43.95

SEGA MEGADRIVE

MEGADRIVE + GAME + POWER PACK.....£129.95

SOFTWARE

TURBO HEDGEHOG.....	POA	GAW GROUND	£29.99
GYNUG	£31.99	SUPER MONACO GP	£32.99
MICKEY MOUSE.....	£29.99	SHADOW DANCER.....	£25.99
MAGICAL HAT	£32.99	KING OF SWORD II	£32.99
BATTLE GOLFER.....	£31.99	E-SWAT	£29.99
DICK TRACEY	£32.99	DARWW 4081	£25.99
WONDER BOY III	£29.99	HURRICANE	£25.99
GHOST BUSTERS	£29.99	HELL FIRE.....	£25.99
SPLATTER HOUSE	£45.99	JOE MANTANA FOOTBALL	£32.99
CRACK DOWN	£29.99	SUPER SHINOBI.....	£38.99
		FANTASY STAR III.....	£25.99

MORE GAMES AND PRODUCTS ARE AVAILABLE. SPECIAL ORDERS AND ONE OFF'S TAKEN.
FOR MORE INFORMATION AND ORDERS RING 0389 5573.
TRADE AND OVERSEA'S INQUIRIES WELCOME.

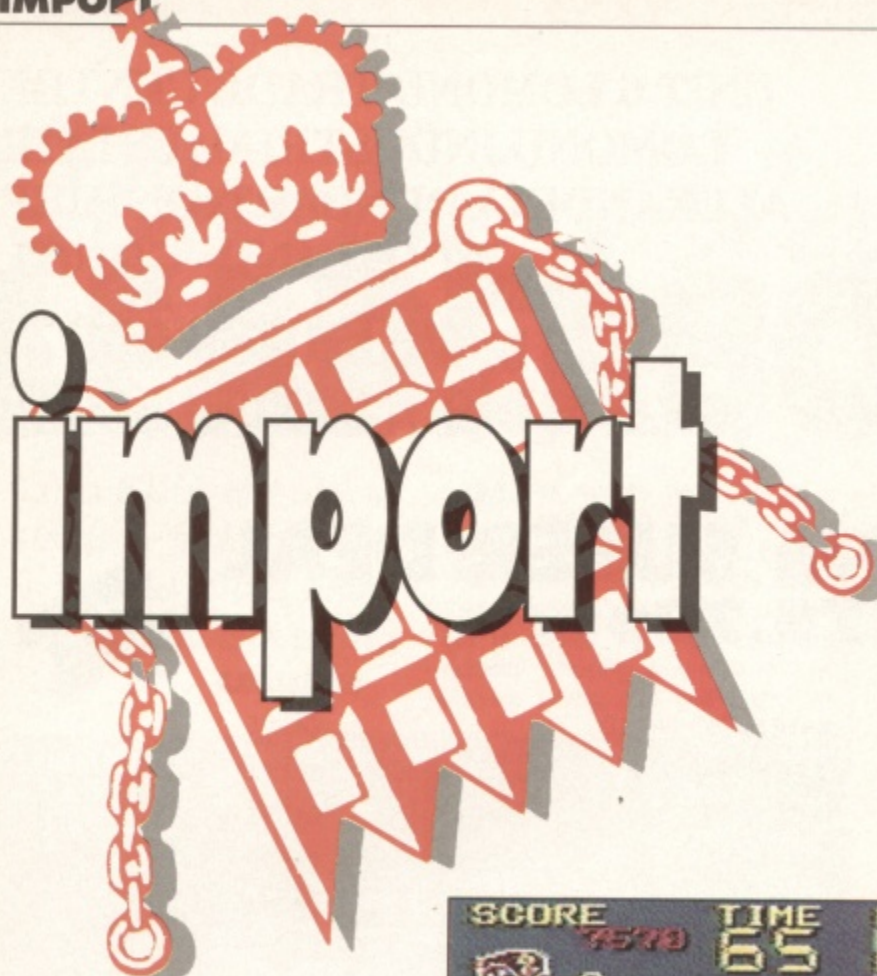

SCI

TAITO • £35

The arcade follow-up to *Chase HQ* has finally arrived on the Engine! The idea is much the same as the original, but instead of ramming the crims off the road you have to blast 'em off.

Practically every element from the great original has survived – even Nancy, your help at police headquarters. After receiving your orders from Nancy, you jump back into your high-



powered pursuit car, which still looks like a cross between an Escort and a Porsche 928S. Time is of the essence as you have just 60 seconds to track down the criminals' vehicle, and a further 60 seconds to destroy it once it's found. Disabling the crims' car, van or lorry is simply done by firing at it constantly.



There are five villains to track down, over five tough, winding levels. At the end of level five, there's a final race to get to the crooks' warehouse. Each level also contains its own helicopter, which will quite generously drop extra weapons for you to pick up. But the weapons, like a rocket launcher, only last for eight mega powerful shots, so they mustn't be squandered.

SCI on the Engine is a stunning conversion. It contains nearly all of the features that were in the arcade machine – even the speech! The background and roadside graphics throughout are excellent and scroll along at an alarming rate. The car sprites are also very detailed and move quite intelligently across the track trying to block you. Finally, music and effects are superb, translating the coin-op with all its sonic glory.

PC ENGINE 89%

VERYTEX

ASMIK • £35

The Mega Drive isn't exactly starved of blasters, is it? And it's not like any of them are particularly bad or anything. Most are very good in fact, and that's why when a new one comes along, it has to be something very special indeed to get noticed in the crowd. Unfortunately for Asmik, *Verytex* looks like it will get lost in the masses.

Power-ups are, of course, in abundance, which to a certain extent is the downfall of the game. After only a few minutes of play you find yourself at maximum power, with nothing to look forward to getting. Even the

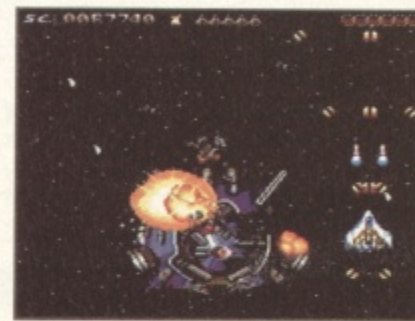

impressive level guardians, which practically fill the whole screen, only require a mild effort to send them to wherever large end-of-level bad guys depart to.



There are some saving graces though. The backdrops are excellently drawn, combining floating space structures with smooth parallax scrolling. The explosions too are fairly smart, and helped by some decent sound effects. It's just a pity that these aesthetic attractions aren't complemented by some depth of gameplay.

MEGA DRIVE 79%

ROLAN'S CURSE

SAMMY • £25

Years ago the people of Rolan were terrorised by the evil King Barius, lord of the demons. But through their great bravery, the Rolans were able to defeat him. But being the nice (stupid) people that they are, instead of killing Barius, the Rolans imprisoned him in a castle sealed with magic.

All was fine till a few years later when an old folks nature tour stumbled on the castle and accidentally opened the doors (contrary to what was written in their National Trust guide book). Barius soon escaped and planned his revenge on the people who had imprisoned him there.

But the people's choice – you – is ready to face Barius and all his old cronies, so the Rolans have nothing to fear – right? You start in your village with little more than a sword

and a few wise words from your elders. From here you just have to wander around the landscape, which is viewed from above, trying to find Barius's main henchmen. As you explore the countryside, you'll come across many wonderful objects that can prove of great use: shields, magic rings, axes, potions, etc. But killing monsters and picking up goodies is just half the fun as you also have to find a gateway that leads to the next area, and even closer to Barius himself.

Rolan's Curse is not a bad little game. Although the graphics aren't poor, they do little more than make the game functional. The sound is also fairly mediocre. The two-player option is a major bonus, allowing both players to venture around the place simultaneously. The major gripe is that the game is just so repetitive, although a password option does reduce some of the tedium.

GAME BOY 64%

PHANTASY SOLDIER III

RENO ● £35

At first look, you could be forgiven for thinking this was another version of *Strider*. The graphics aren't quite as stunning, but there are



those ubiquitous sloping platforms, and you have a special magic sword and even perform a skidding stop. But these are just similarities, the differences are many; the primary one being that you play a



woman.

After a thoughtful cartoon telling you the story at the beginning, you get straight into the action. Like *Strider*, you can run, jump, crouch and fire. There is also a wide choice of magic, although this must be used wisely as it is limited. On some levels you can also change the character under your control, from a young girl who looks like your fairy godmother to another



who's dressed up as a lion (with a whip!).

The immense attention to detail and depth of content make *Phantasy Soldier III* a pleasure to play. Visually, each level varies greatly from the last. All the action



takes place in front of some very smooth parallax scrolling, which adds greatly to the atmosphere. This is then polished off by a four minute cartoon sequence at the end of every level, detailing your progress. It's no wonder that *Phantasy Soldier* is into its third airing.

MEGA DRIVE **85%**

POWER MISSION

NTVIC ● £25

Strategy fans are not really that well catered for on the Game Boy, but all that is about to change!

The year is 1999 and the country of Jagoda has just attacked your islands with their powerful battleships. Your job, as the commanding officer, is to destroy this enemy fleet using the fleet of ten units under your control. The fleet contains anything

from battleships and cruisers to destroyers and submarines.

The game is set out over a map split into a 28x28 grid. After placing your own ships, you can try to locate the enemy's by either using a radar or moving one of your ships closer. Attacks should be launched with caution as you only have a limited supply of ammo. In all there are 11 enemy fleets to destroy, and each of them gets craftier as you progress.

Okay, I admit it, *Power Mission* is actually Battleships under a different guise. However, this doesn't mean that it isn't any good. The suspense

certainly builds up when you are moving into enemy territory, which is enhanced in two-player Game Link mode. *Power Mission* doesn't boast stunning graphics or a pounding soundtrack, but it does have immense addictive qualities. A suitable alternative if you can't find two pencils and a notepad.

GAME BOY **75%**

HAL WRESTLING

HAL AMERICA ● £25

Are you grossly overweight? Do you wear Y-fronts and bover boots? Do you enjoy inflicting immense pain on other people like yourself? Is your name Julian Boardman? If so, then Hal have come up with the ideal wrestling game for you.

At the start of the game you decide whether you want to play versus the computer, or another player (down the Game Link), or take part in a four-man elimination match. You then choose one of the eight fighters available, each who has 14 moves, from a Brain Buster to an Atomic Drop.

It all sounds quite intriguing, but *Hal Wrestling* is a little bit of a disappointment. The sprites are good but very blocky, sometimes making it hard to tell which wrestler you are controlling. Similarly, the music isn't that bad, but it does irritate after a while. Most of all, the matches take far too long to run their course, making the game very tedious. Even people born with their underpants over their trousers would find this hard to enjoy. When is a wrestling game going to capture the real atmosphere of the American sport?

GAME BOY **58%**

THANKS FOR THE (READ ONLY) MEMORIES

Many thanks to Console Quest and Console Quest for supplying the games that appear in this month's Import.

Console Quest, 1 Ashacre Mews, Offington, Worthing, West Sussex BN13 2DE. Tel: 0903 693623.

Console Concepts, The Village, Newcastle-Under-Lyme, Staffordshire ST5 1QB. Tel: 0782 712759.

FATMAN

Mega Drive

Do you want to change your fighting character? Just press these buttons on the title screen:

BUFF - LEFT, C, B

MC FIRE - DOWN, C, RIGHT

ROBOCHIC - RIGHT, UP, DOWN

BONAPARTE - A, UP, C

RABIO LEPUS

PC Engine

To get six credits, hold down SELECT on the title screen and press button I once, button II twice, button I three times and button II four times.

DEVIL CRASH

PC Engine

To enter the sound check, PAUSE the game, and press SELECT, DOWN and button I together. To play with 48 balls, enter P P P P P P M N as the password.

DARIUS PLUS

PC Engine

To change the difficulty level, press SELECT and button I on the title screen.

POWERDRIFT

PC Engine

Stage select: On the title screen, hold DOWN-RIGHT, SELECT, button I and press RUN. Select Jason and press II the number of times corresponding to the stage number you want to reach.

Invincibility: On the title screen, hold DOWN-RIGHT, SELECT, button I and press RUN. Go to Mark and press button II. You can now choose any character you like. Thanks to Darren Cheung in Miramar, New Zealand for those PC Engine tips.

BUBBLE BOBBLE

Game Boy

Enter the code KGBJ and you can play on the last level. You can also play on any level from 1-100 using this code. Just use the LEFT and RIGHT buttons.

FORTRESS OF FEAR

Game Boy

Right at the start of the game there is an extra life. When you begin the game, jump forward and then jump back to the platform above and to your left. Walk to the end of the platform and jump onto the cloud that appears. Jump from the cloud onto the bridge and pick up that bonus life!

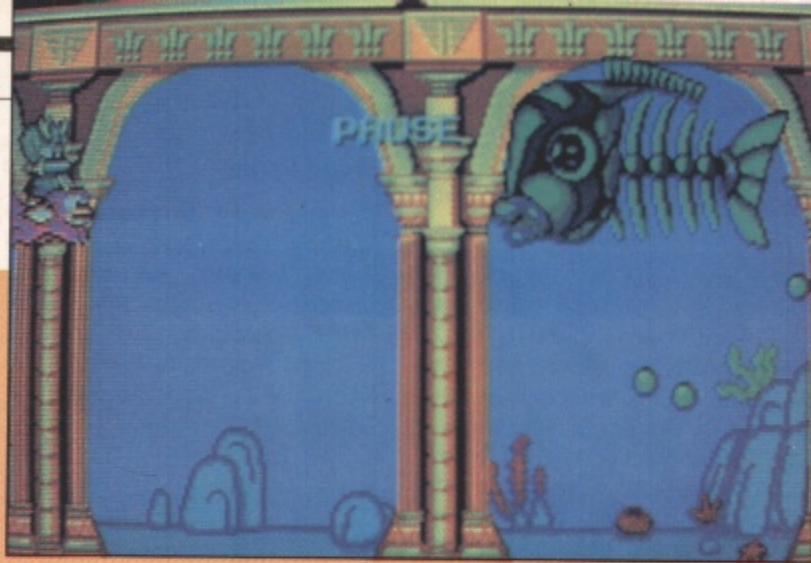

WONDER BOY III MONSTER LAIR

MEGA DRIVE ● SEGA ●
£30

Wonder Boy, that little bouncing loverboy, is back in a whole new game. But bear in mind that this is a conversion of the arcade machine, and nothing like the third game on the Master System. In your latest escapade you are joined by your close companion Wonder Girl on an adventure through nine action-packed levels.

There are two sections to the game – walking and flying – both containing an armoury full of weapons. The walking part is the hardest section, combining the shoot-'em-up elements of the flying section with obstacles, a larger variety of creatures and more interactive landscape features.

By shooting the creatures in the Monster Lair, you can get them to drop either fruit or weapons. The fruit will boost your energy (which depletes on contact with animals) while the weapons only last for a few screens when you're returned back to a pea shooter.

At the end of each flying section

Watch your step, there could be something fishy going on here. Get out of the way when this guy starts to spit.

(where Wonder Boy and Girl jump on friendly dragons), you encounter a big, mean, ugly animal. It could be a snake, or a bat, or even a hive of bees. But, beware, sometimes you may think you've polished off a guardian, when it could just reveal something even more menacing!

The graphics are very colourful, although they slow down a bit when there's too much going on. The sound, too, is relatively happy, although not a patch on the PC Engine CD-ROM version (understandably). A very addictive game, that's great fun in two-player mode with loads of continues.



MEGA DRIVE **81%**

AMBITION OF CAESAR

MEGA DRIVE ●
MICRONET ● £30

War games are always a bit of an oddity on the Mega Drive. For a machine that's aimed at the shoot-'em-up fanatic so much, it's a surprise to see any war games at all. Still, Shintaro Kanaoya's always moaning on about the unoriginal Japanese game market, so war games must be a breath of fresh air for the little chap. And, let's face it, when the Japs put their minds to it, they come up with some of the most accurate war games around – just look at any Koei game for proof.

The title of this says it all. You play the part of the Roman general Caesar who must basically survive all sorts of attacks from other kingdoms, whilst trying to expand the Roman empire into other territories.

You have control of your armies right down to the garrison in each town. Most of the action takes place on a square grid, from which you can move your forces around the countryside. When you bump into an opposing force, the action zooms in close for a man-to-man look at the conflict. It's worth noting that no control is had over individual aspects of your garrison, so you must sit back and watch as either your ill-prepared garrison gets well and truly trounced or the opposition start to eat dirt as you overpower their weaker forces.

VOLFIED

MEGA DRIVE ● TAITO ●
£30

Even when this game came out on the PC Engine, it was considered pretty old hat. But now Taito have tried to fob us off with it on the Mega Drive. This game is simple – very simple – and the programmers have done the impossible with the Mega Drive version and made it unplayable! How could they have made a *Painter* clone unplayable? Unbelievable.

Okay, so this isn't quite your basic

odd alien creatures which travel around your trails and swirl around in the empty space.

It seems odd that *Volfied* should be released at exactly the same time as *Qix* on the Game Boy, an

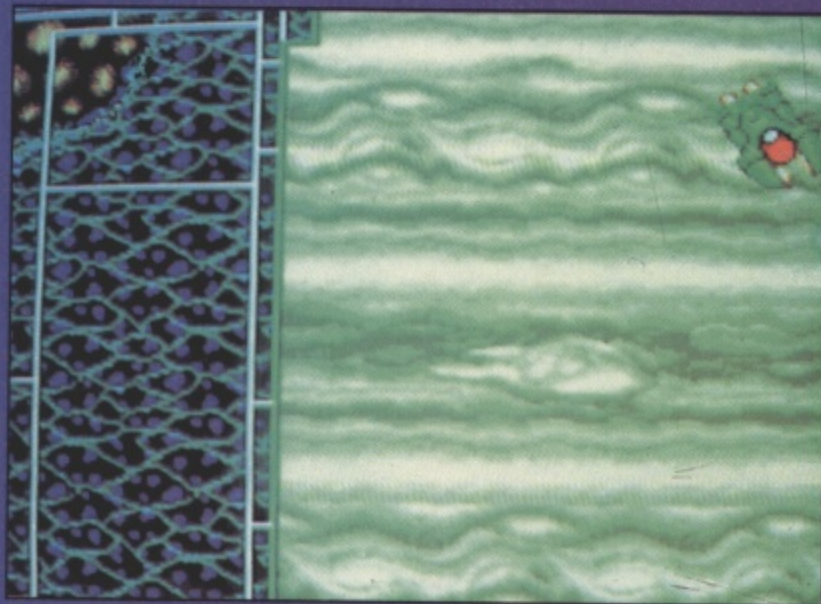
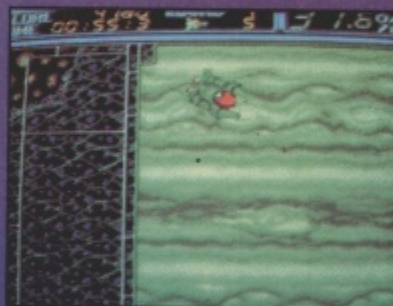

Painter game, there are a few extra elements. For a start, you don't have to fill the whole screen, from 75%-90% will suffice, depending on your level. Also, you get to pick up little goodies like lasers, speed, lives, etc, to help you survive the

almost identical game. Are we trying to progress, or just digging up old ideas that programmers hope we have forgotten?

MEGA DRIVE **64%**

There's a good range of difficulty levels, helping even beginners to get into the cut and thrust of military encounters with few headaches. Overall, the graphics are quite impressive – for a war game – and the battle screens show particular

finesse. A good introduction to war gaming, yet a tough challenge for experienced warriors.

MEGA DRIVE **79%**

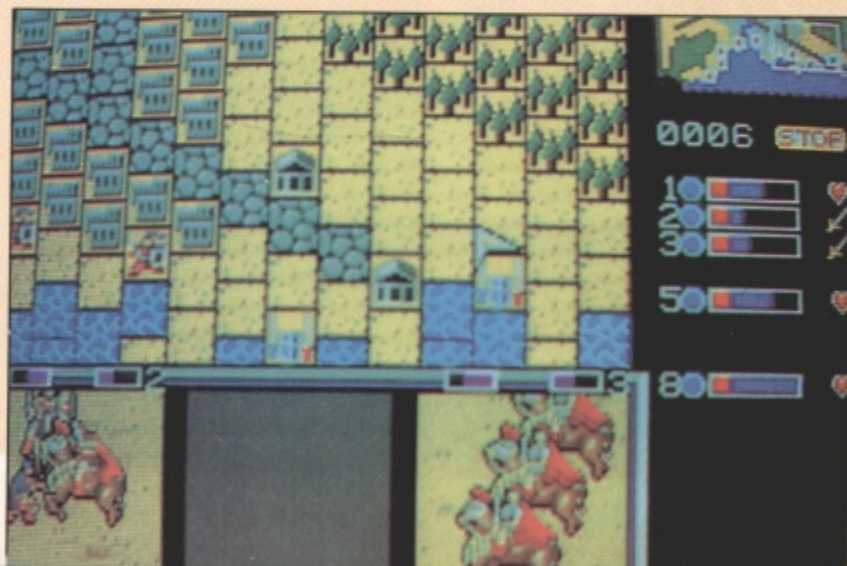

VIDEO GAME CENTRE

870 WIMBORNE ROAD, BOURNEMOUTH BH9 2DR

★ NINTENDO, SEGA, LYNX, GAMEBOY, MEGADRIVE, FAMILICOM ★

MEGADRIVE

Flicky.....	19.99
Space Invaders 91.....	29.99
James Pond.....	29.99
John Madden Football.....	32.99
Air Buster.....	33.99
Hellfire.....	36.99
Sagia (Darius II).....	36.99
Wings of War.....	36.99
Abrama Battle Tank.....	39.99
P.G.A Tour Golf.....	39.99
Gaiars.....	39.99
Sonic The Hedgehog.....	Call

GAMEBOY

Garglyics Quest.....	18.99
Rolan's Curse.....	19.99
Dragon's Lair.....	19.99
Bubble Bobble.....	24.99
Chessmaster.....	24.99
W.W.F. Superstars.....	24.99
Operation C.....	24.99
Final Fantasy (R.P.G.).....	24.99
No Bunaga (R.P.G.).....	24.99
Duck Tales.....	24.99
Fish Dude.....	22.99
F1 Race (inc 4 player Adaptor).....	29.99

HARDWARE & ACCESSORIES

Gameboy.....	69.99
Lynx Cigarette Adap.....	9.99
Megadrive (Pal).....	119.99
Atari Lynx (inc Game).....	99.99
Turbo Express.....	239.99
M.D. Hard Carry Case.....	34.99
M.D. Arcade Powerstick.....	34.99
G.B. Lightboy.....	19.99
G.B. Gamelight.....	9.99
G.B. Carry All.....	14.99
Lynx Pouch.....	12.99
Lynx Kit Case.....	16.99

+ We have loads more games & accessories in stock.
Please phone or send S.A.E. for latest games & prices.
All prices include V.A.T. & p&p. All orders sent same day.

(0202) 527314



MEGADRIVE

S. FAMILICOM

NEW
MEGADRIVE
CHARTS

MICKEY MOUSE £24
HELLFIRE £22 CRACKDOWN £24
WONDERBOY 3 £23 SHADOW DANCER £24
BATTLE GOLFER £28 MAGICAL HAT £24

CART EXCHANGES £3

USED CARTS BOUGHT & SOLD

PART EXCHANGE YOUR USED TITLES
FOR ANY NEW TITLES

FAMILICOM HIRE CLUB - £3 PER WEEK
PLEASE CONTACT US

TEL (0736) 50130

MON - SAT 5 p.m. - 10p.m. SUN 11a.m. - 9p.m.

FOR A FULL PRICE LIST, TELEPHONE OR SEND S.A.E.

CART SERVICES, 21 REENS CRES, HEAMOOR, PENZANCE, CORNWALL TR18 3HW

PORTABLE POWER

ATARI LYNX

Atari Lynx including power supply & comlynx adaptor£95
Atari Lynx supplied on its own£75

Warbirds.....	27.50	Ms PacMan.....	27.50
Fidelity Chess.....	32.50	Road Blasters.....	27.50
Ninja Gaiden.....	27.50	Slimeworld.....	27.50
World Soccer.....	27.50	Xenophobe.....	27.50
Blue Lightning.....	27.50	Rampage.....	27.50
Chips Challenge.....	27.50	Robo Squash.....	27.50
Electrocop.....	27.50	Rygar.....	27.50
Gates of Zendecon.....	27.50	Shanghai.....	27.50
Gauntlet 3rd Encounter.....	32.50	Paperboy.....	27.50
Klax.....	27.50	Zarlor Mercenary.....	27.50

GAME BOY

Nintendo Game Boy supplied with free adaptor, earphones &
Tetris.....£65.99

Double Dragon.....	18.99	Spiderman.....	18.99
Balloon kid.....	18.99	Super Marioland.....	18.99
King of the Zoo.....	18.99	Tennis.....	18.99
Revenge of the Gator.....	18.99	Oix.....	18.99
Kwirk.....	18.99	Solar Striker.....	18.99
Fortress of Fear.....	18.99	Alleyway.....	18.99

Please make cheques payable to The Words Works Ltd
or pay by credit card and send details to:

Mail Order, The Words Works Ltd, FREEPOST
(SN 1543), Trowbridge, Wiltshire, BA14 8YA.
Or place your order by phone on 0225 765086

MEGA HIRE

IMPORTERS AND EXPORTERS OF ALL
ENTERTAINMENT CONSOLES AND CARTRIDGES
TRADE ENQUIRES WELCOME!

HARDWARE

SEGA MEGADRIVE (PAL-I) + MICKEY MOUSE.....	£185
SUPER FAMILICOM (SCART) + FINAL FIGHT + ACT RAISERS.....	£299
SUPER FAMILICOM (PAL-I) + GAME OF YOUR CHOICE.....	£350
NEO-GEO CONSOLES.....	£280
ALL GAMES FROM.....	£120
JOY JOY KID.....	£130
LEAGUE BOWLING.....	£130

STOP THE PRESS
ALL OUR PAL SUPER FAMILICOMS ARE
CONVERTED IN JAPAN SO
ARE ABSOLUTELY PERFECT.
DON'T RISK YOUR MONEY ON POOR
QUALITY CONVERSIONS

SEGA MEGADRIVE

MICKEY MOUSE.....	£25
MIDNIGHT RESISTANCE.....	£38
DICK TRACY.....	£30
DARIUS II.....	£32
GAIRIES.....	£32
MAGICAL HAT.....	£29
GYNUG.....	£30
SUPER AIRWOLF.....	£32
VERYTEX.....	£30
LAKERS Vs CELTICS (USA).....	£38
SONIC THE HEDGEHOG (USA).....	£38

NINTENDO SUPER FAMILICOM

FINAL FIGHT.....	£45
ACT RAISER.....	£40
GRADIUS III.....	£40
PILOT WINGS.....	£40
F-ZERO.....	£40
MARIO WORLD.....	£40
POPULOUS.....	£38
BOMBUZAL.....	£38
R-TYPE II.....	£48
ULTRAMAN.....	£48
DARIUS TWIN.....	£48

RING FOR BRAND NEW + SECOND HAND LISTS
PART EXCHANGE AVAILABLE ON ALL MACHINES!

GAME GEAR GAMES ALL £25

ALL ITEMS SENT BY RECORDED DELIVERY.
MAKE CHEQUES + P.O. PAYABLE TO MEGA HIRE.
ADD £1 PER ITEM P+P. CONSOLES ADD £5

2 DARFIELD HOUSE, DARFIELD COURT,
TICKHILL, DONCASTER, DN11 9HV
PHONE/FAX: 0302 751428 (8am to 8pm 7 days)

WIN A SUPER FAMILICOM WIN A SUPER FAMILICOM WIN A SUPER FAMILICOM

CALL MEGALINE, THE COMPETITION LINE
THAT'S SPONSORED BY MEGA HIRE
WIN A SUPER FAMILICOM
EVERY CALLER RECIEVES THE LATEST MEGA HIRE PRICE LIST

0839 654269
0839 654269

PLEASE ASK PERMISSION OF THE PERSON THAT PAYS THE BILL
CALLS CHARGED AT 34P PER MINUTE CHEAP RATE AND 45P PER MINUTE ALL OTHER TIMES

WIN A SUPER FAMILICOM WIN A SUPER FAMILICOM WIN A SUPER FAMILICOM

KEENHELM BOX 256 NN1 4LA

NORTH EASTERN CONSOLES
UNIT 9
FRONT STREET
WHEATLEY HILL
CO DURHAM
TEL:0429 820 830
FAX: 0429 820066

DISTRIBUTORS FOR
ALL REQUIREMENTS
FOR A FAST,
FRIENDLY
+EFFICIENT SERVICE
PERSONAL CALLERS
WELCOME
OPEN 10AM - 6 PM
MON-SAT



JAP MEGADRIVE
(PAL) £99.95
JAP MEGADRIVE
(PAL) + 1 GAME
£115.00

PLEASE NOTE OUR
MEGADRIVES PLAY
GENESIS/BRITISH/JAPAN
ESE GAMES +ALL
MACHINES ARE
GUARANTEED

SUPER FAMILICOM
£199
SUPER FAMILICOM +
2 GAMES £249

MEGA DRIVE	GAMEBOY	FAMILICOM	WE ALSO SUPPLY
ATOMIC R. KID.....24.95	W W F.....24.95	SIM CITY.....38.95	JOYSTICKS
GAIN GROUND.....24.95	SPIDERMAN.....24.95	ACT RAIZOR.....38.95	JOYPADS
HELLFIRE.....24.95	DRAGONSLAIR.....24.95	F ZERO.....38.95	POWER STICKS
WONDERBOY.....23.95	POWER.....	AUGUSTA GOLF.....38.95	POWER SUPPLIES
DICK TRACEY.....27.95	MISSION.....24.95	FINAL FIGHT.....38.95	LIGHT BOY
MAGICAL HAT.....28.95	T M N TURTLES.....24.95	GAIRIES.....38.95	CARRY CASES
VERY TEX.....27.95	NBA ALLSTARS.....24.95	PILOT WINGS.....38.95	MAGNIFIERS
E-SWAT.....26.95	BUBBLE.....	GREAT BATTLE.....38.95	ILLUMINATORS
J MONTANA.....26.95	BOBBLE.....24.95	BIG RUN.....38.95	AMPLIFIERS
KA GE KI.....32.95	SERPENT.....24.95	S MARIO.....38.95	SCART LEADS
TIGER HELI.....32.95	R TYPE.....24.95	ULTRAMAN.....38.95	COMPUTER PERIPHERALS
R ANGELS.....31.95	FASTEST LAP.....24.95	TWIN DARIUS.....38.95	UNBRANDED DISKS
BATMAN.....32.95	BATMAN.....24.95	POPULOUS.....29.95	DISK DRIVES
BATMAN.....32.95	GOGO TANK.....22.95	GHOULS & GHOST.....	MICE
STRIDER.....32.95	CHASE HQ.....22.95	UN SQUADRON.....TBA	
BONANAZA.....	CHESSMASTER.....24.95	R-TYPE.....TBA	
BOYS.....28.95	IN YOUR FACE.....TBA		
FLICKEY.....28.95	SPUDS.....		
	ADVENTURE.....TBA		

CALL FOR BEST PRICES AND ALL THE VERY LATEST, UP-TO-
DATERELEASES.

OTHER TITLES ARE AVAILABLE FOR ALL FORMATS
PLEASE ADD £6.00 p&p FOR MACHINES + £1.00 PER GAME.

PLEASE MAKE CHEQUES & PO'S PAYABLE TO:
NORTH EASTERN CONSOLES.

BUDGET GET BUILT UP



With the rise in VAT, Sir Ivor Tightwallet says that if you're a budget buyer, you've never had it so good

THE WINNING TEAM

DOMARK ● £29.99

What with the launch of their £7.99 Respray label and a constant supply of good quality compilations, Domark have taken the budget market by storm over the past months. However, Domark have very strict rerelease conditions, which means that most of their cheapies are either



Vindicators and Cyberball.

Klax is one of those games that followed in the wake of Tetris. The screen shows a large hand holding a conveyor belt down which coloured tiles tumble. The idea is to arrange the tiles in a basket at one end of the conveyor so that

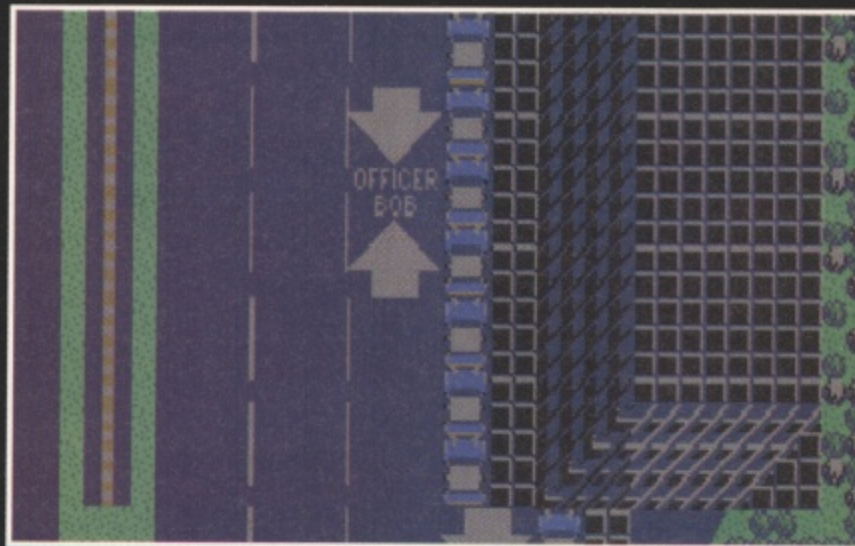

On your way back to the station, after a hard day's work, your boss gives an appraisal. He's happy today, but tomorrow you could be thrown into the dustbin as a disgrace to the Force.

so old that nobody wants them, or, as is more the case, the games have already appeared on compilation elsewhere. But choice isn't always a bad thing, and if you thought twice about buying a compilation to get that elusive game, you could well find that the game's been released on its own in the Respray collection.

Domark's bullishly titled *The Winning Team* isn't exactly the best collection of games to hit the market, but it is interesting in that it contains some titles which you might have thought about buying first time around, but just resisted at the last moment. On offer are *Klax*, *APB*, *Escape from the Planet of the Robot Monsters*,

they align with tiles of the same colour to form three in a row (known as a klax). There's some great digitised speech and applause to liven up the game, and



After doing a world tour of every console and computer format, *Klax* returns on *The Winning Team* compilation from Domark.

a two-player mode increases the lastability.

Domark's Tengen tie-in, *APB*, is just the thing for all you budding coppers out there. You play a rookie cop who has to venture around dangerous city streets clearing them of the filth of crime. Your captain briefs you before each mission, telling you what arrest quota the City expects of you. Later into the game, you are issued with an All-Points Bulletin, detailing criminals who must be picked up on your way to Dunking Doughnuts. Overall, this is a very amusing and addictive little game, although it has already appeared on the *TNT* compilation.

Unlike most arcade adventures, *Escape from the Planet of the Robot Monsters* doesn't take itself too seriously - thank goodness. The two main characters, Jake and Duke, are enlisted in an inter-planetary SWAT team who must travel to a robot-infested planet and rescue hundreds of beautiful young women - including the sultry Sarah Bellum MD. It seems that the prof and her colleagues have been captured by the robots who want to turn them into Robo-Zombies. The action takes place on a *Marble Madness* type land-

Between the levels, there are mazes to be explored. You have 30 seconds to reach your ship at the end of the maze.



OPERATION WOLF

THE HIT SQUAD ● £7.99

scape, although the inhabitants are a lot more hostile towards visitors. Loads of blasting makes for frenetic fun, and the added attraction of teamwork ensures this is one game that you can come back to and still have fun.

Similarly, if you play *Vindicators* you'd do well to coax a friend into joining you. You both take control of futuristic battle tanks which have to clear 14 space stations of alien infestation. A small amount of strategy is needed to ensure you don't run out of fuel, but

Mind your backs, here come Ocean's Hit Squad to storm the charts and blow away the competition. In particular bad taste, they release *Operation Wolf*. Still, if you want a damn good, mindless blast, then here's your game.



DALEY THOMPSON'S OLYMPIC CHALLENGE

THE HIT SQUAD ● £7.99

Even when this originally came out, it was thought to be a bit dated. But three years on, *Daley's Olympic Challenge* is most positively dead. The trouble is that (most) gamers have progressed past the dubious skill of being able to waggle a joystick quickly left and right.

DT's (dubious) *Challenge* consists of ten events that take place over two days. Before entering the contest, you get the



ics are quite neat, but they can't save a concept that's almost as old as Daley himself.

AMIGA 66%
ATARI ST 60%

This conversion of the Taito coin-op was a massive success when it was released in 1988, putting all other shoot-'em-ups to shame with its detailed graphics and innovative perspective. You take the role of the super-tough American soldier whose task is to



penetrate enemy territory and rescue American POWs. The game is split into six different stages, from an enemy camp to the jungle and finally to the airport where you must protect civilians trying to catch a lift on your B-52.

The arcade machine came complete with a cabinet-mounted uzi, but even without that you can have some great fun. A great range of graphics and some super digitised sound effects make for a blasting good time.

AMIGA 79%
ATARI ST 76%



mostly whoever gets the best power-ups lasts the longest.

Do you remember those old Spectrum games where there was limited colour and the characters moved an inch at a time? Well, now you can bring back those old memories with *Cyberball*, a sort of American football in the 21st century. Basically, Americans have finally realised the danger of their great sport and have designed robots to take the punishment instead. Apart from that, there's very little difference between this and an American football game programmed in BASIC on the Spectrum. Speed and graphics hold this game back, just look at the superior Mega Drive version.

Taking into account the fact that every compilation must have one duffer game on it, *The Winning Team* doesn't look too bad. But with all of the games either out now or on their way for £7.99 from Respray, you'd be a fool to spend £25 unless you liked at least three of the titles.

AMIGA 77%
ATARI ST 74%

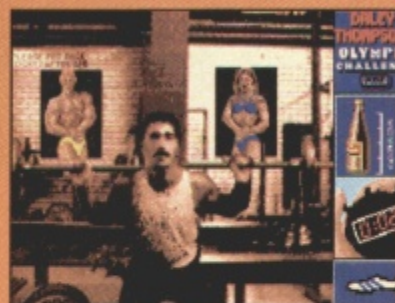

The first of the training sessions where we see Daley busy pumping iron to earn those precious cans of liquid energy.

chance to earn cans of L*c*z*d* by bench pressing, picking up weights, etc. The cans of fizz can be used during an event to give you an extra burst of energy, so use them wisely.

The events are 100m sprint, long jump, shot-putt, high jump, 400m, 1500m, javelin, pole vault, discus and 110m hurdles. The ultimate aim is to score over 9000 points and become a true superman. Admittedly, the graph-

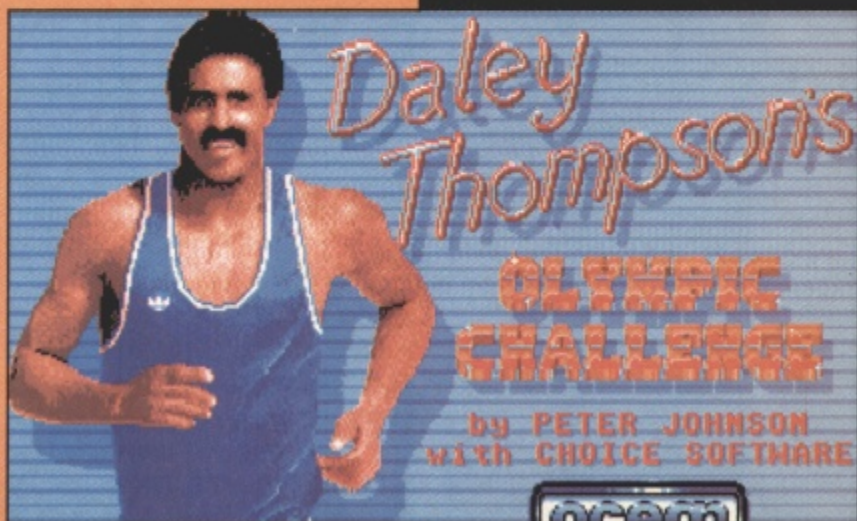



BUDGET TIPZ

SHADOW OF THE BEAST

Amiga

Also appearing on *The Monster Pack*. If you hold down the joystick FIRE button and the LEFT MOUSE button on the last title screen until you have to change the disk, you get infinite lives.

SUPER HANG-ON

Amiga

This racing game from *The Hit Squad* has some stonkin' cheats in it. When you get to the top of the novice leaderboard, type YH50 as your name. This makes your bike faster, giving it better road holding and a machine gun.

SKIDZ

Amiga

If you're still stuck on Gremlin's ecologically conscious game on the 16-Bit *Hit Machine* then hold down ALT+C for infinite energy or ALT+M to skip levels.

INDIANA JONES

Amiga, Atari ST

Enter your name as SILLYMAN for infinite lives.

BATMAN

Amiga

Ocean's *Hollywood Collection* compilation contains four tip-hungry games. I've dug up cheats for all of them. Type in JAMMMM on the title screen for infinite lives in *Batman*.

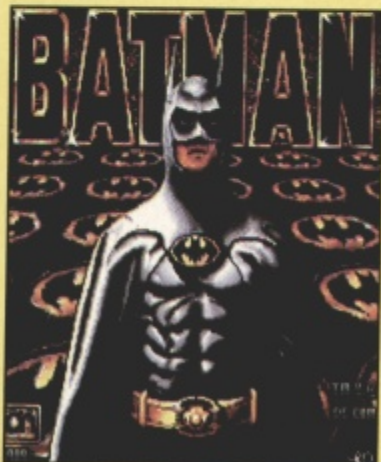

GHOSTBUSTERS II

Amiga

When the Activision logo appears, press CTRL+ALT+S+U to give you infinite courage on level one and infinite slime on level two.

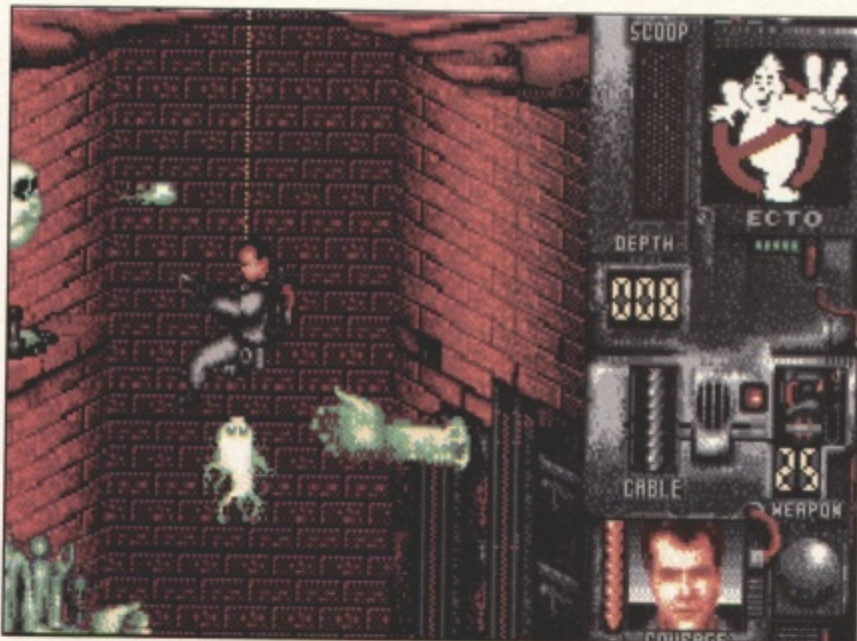

APB

Amiga, Atari ST

If you enter your name as ALF you get infinite demerits, making it infinitely easier to clear the streets of scum. Also, when on the title screen push UP on the joystick and press FIRE. This lets you start on screen 16.

ROBOCOP

Amiga

Hold down SHIFT and type ALEX MURPHY. Press FIRE on the joystick and every time you press the LEFT MOUSE button your power will be restored to full.

XYBOTS

Amiga, Atari ST

Believe it or not the cheat is exactly the same as APB. Enter your name as ALF to get unlimited energy.

MIAMI CHASE

Amiga, Atari ST

To clear level one with hardly any damage to your car, just stay at the very top of the screen under the trees. Now hold the FIRE button down and drive backwards and forwards. It seems that all the enemy cars get attracted to you, making them easy targets.

SILKWORM

Amiga

One of the best shoot-'em-ups around is great value at £9.99. On the control select screen, press F10+HELP+FIRE for infinite lives. The keys 1 to = will select the level.

★ If you've had enough of the *Ninja Turtles* then look out for MicroValue's next release, entitled *Ninja Rabbits*. It should be out now and will set you back two carrots, a lettuce and £6.99 on Amiga and ST, while PC owners have to shell out £9.99.

★ Mirror Image are continuing to release some blasts from the past. The next in line for the new image is *3-D Pool*, originally released by Firebird two years ago. All three 16-bit computers will get it for £9.99.

★ As well as *Operation Wolf*, *The Hit Squad* are rereleasing *Rambo III*, *IK+*, *Predator* and *Platoon*. Is there no end to this violence? All on Amiga and ST at the normal Squad price of £7.99.

★ Accolade are releasing yet another compilation, this time based around sports, and suitably titled *Accolade Pro Sports Challenge*. Featuring *The Cycles*, *Powerboat USA*, *Offshore Superboat Racing*, *Jack Nicklaus' Greatest 18 Holes of Major Championship Golf* and *Jack Nicklaus' Major Championship Courses of 1989*. If that little lot tickles your fancy then save up your £29.99 for the Amiga and PC versions now.



★ Gremlin have finally given in to the pressure from the public and launched a new budget label called, strangely, GBH. (They said they wanted something with punch.) Six titles are planned for the initial launch, with prices in the £7.99-£9.99 bracket: *Supercars*, *Footballer of the Year II*, *Impossimole*, *Venus: the Fly Trap*, *Ultima Golf* and *Combo Racer*. All titles are Amiga and Atari ST only, except for *Ultima Golf* which also appears on the IBM PC.



MEDLANTIC HI TEC PRESENTS . . .

THE INCREDIBLE SUMMER SALE

GYNOUG	32.99
ESWAT	19.99
HELLFIRE.....	19.99
D J BOY	19.99
GAIRES	33.99
MICKEY MOUSE.....	24.99
MAGICAL HAT	24.99
S DANCER.....	22.99
STRIDER.....	29.99
RAINBOW	26.99
R ANGELS.....	33.99
W BOY III.....	24.99

ALL SECOND GAMES.....17.00

MEGADRIVE + ANY GAME.....	139.00
NEW GAMES	
JAMES POND.....	37.00
PGA GOLF.....	38.00
M RESISTANCE	37.00
S AIRWOLF.....	37.99

MORE TITLES IN STOCK.
TRADE ENQUIRIES WELCOME

ALL GOODS DESPATCHED WITHIN 24HRS.

PLEASE SEND ALL CHEQUES/POSTAL ORDERS TO:
MEDLANTIC HI TEC LTD.
10 CHURCH ST
MARKET BOSWORTH
WARKS CV13 0LG
TEL: (0455) 291865 / (0868) 444587

ACCESS/VISA TAKEN

**SUPER FAMICOM
+ 2 GAMES
289.99**

S. MARIO 4	39.00
FO	40.00
BOMBUZAL.....	38.00
HOLE IN ONE.....	43.00
FINAL FIGHT.....	43.00
BIG RUN.....	49.00
DARIUS TWIN.....	49.00

PLEASE CALL FOR LATEST TITLES.

**GAME BOY DELUXE
WITH 2 GAMES +
CARRYCASE
79.95**

D. DRAGON.....	23.00
CONTRA.....	23.00
B BUNNY.....	23.00
B GHOST.....	23.00
SPITERNAN.....	23.00
R-TYPE.....	26.00

MORE IN STOCK

**ALL SECONDHAND
SEGA GAMES
£13.00**

**ALL SECONDHAND
PC ENGINE GAMES
£13.00**

**ALL SECONDHAND
LYNX GAMES
£15.00**

NINTENDO SYSTEM.....	89.00
P. GLOVE	44.95
AMERICAN GAMES CONVERT.....	15.00
MARIO 3	40.99
SIMPSONS	40.99
MEGAMAN 3	40.00
TMNT 2	40.00
DUCK TALES.....	40.00

MORE IN STOCK

CONSOLE WORLD

SEGA MEGADRIVE + ANY GAME	£140
SONIC THE HEDGEHOG (8M).....	£ 42
MIDNIGHT RESISTANCE (8M).....	£ 44
STRIDER (8M).....	£ 34
MICKEY MOUSE	£ 30
GHOULS 'N' GHOSTS (6M)	£ 40
DICK TRACY	£ 34
WONDERBOY III	£ 32
GAIRES	£ 34
MOONWALKER	£ 32
DARIUS 2 (8M).....	£ 38
SUPER AIRWOLF.....	£ 34
GYNOUG	£ 32
MAGICAL HAT	£ 32
JOHN MADDENS	£ 36

**ALL LATEST + OTHER TITLES
IN STOCK - PLEASE PHONE**

STEREO MEGADRIVE SCART LEAD	£ 16
ARCADE POWERSTICK	£ 35
JOYPAD	£ 15
AUTOFIRE JOYPAD.....	£ 20
JAPANESE CONVERTER.....	£ 15
8 BIT CONVERTOR	£ 28

ALL LATEST + OTHER TITLES IN STOCK

PLEASE ADD £1 P+P PER GAME £5 PER CONSOLE
TRADE INQUIRIES WELCOME

**SHEFFIELDS No.1
CONSOLE SHOP**

NINTENDO SUPER FAMICOM + 1 GAME	£285
+ 2 GAMES.....	£315
SUPER MARIO WORLD	£ 45
DARIUS TWIN	£ 45
F-ZERO	£ 45
ACTRAISERS (U.K. HELP).....	£ 45
GRADIUS III.....	£ 45
PILOTWINGS	£45
FINAL FIGHT	£ 45
HOLE IN ONE	£ 45
SUPER R TYPE	£CALL
SUPER GHOULS 'N' GHOSTS	£CALL
ULTRAMAN.....	£ 50
AUGUSTA GOLF	£ 60

**ALL LATEST + OTHER TITLES
IN STOCK - PLEASE PHONE**

SCART TO SCART EXTENSION LEAD.....£18

U.S. GAMEBOY GAMES.....	£ 30
JAPANESE GAMEBOY GAMES.....	£ 25



CONSOLE WORLD MAIL ORDER:

0709 893066

+ ALL INQUIRIES (9-6)

23 MATILDA ST., FURNAL HOUSE, SHEFFIELD

ALL ORDERS - SAME DAY DISPATCH - 1st CLASS RECORDED DELIVERY -
CALLERS WELCOME

ALL CONSOLES CARRY A 12 MONTH GUARANTEE

SLOTS

TO

DO

Suzi Uki

FE

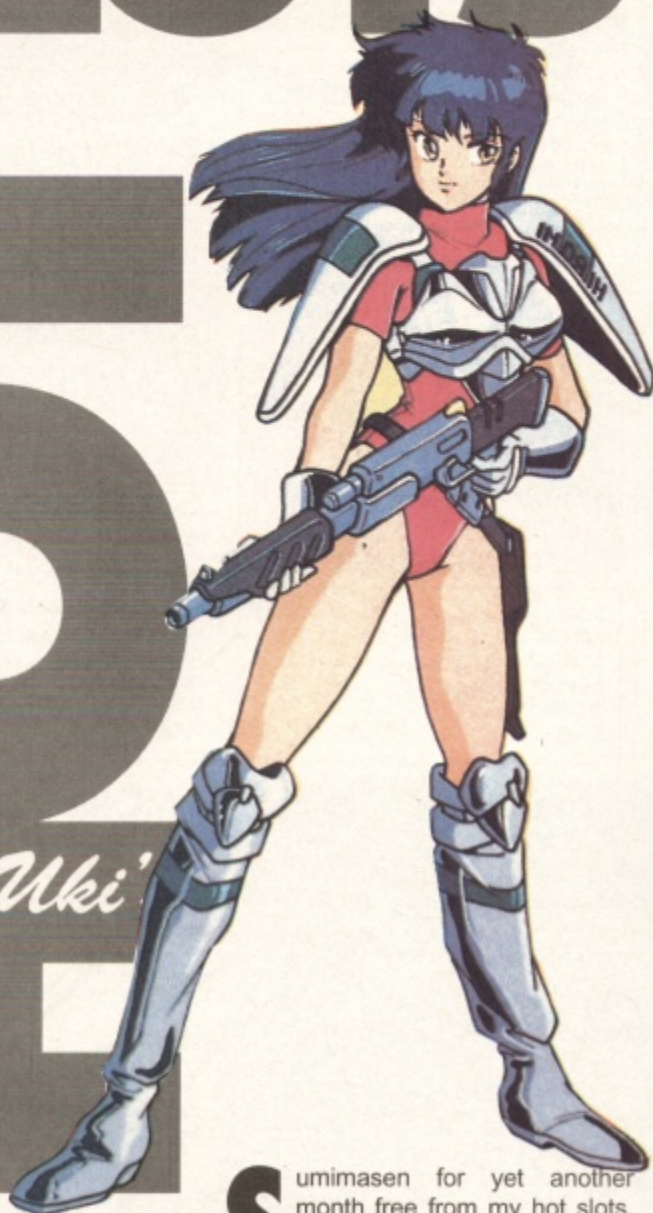

The Oriental orifice pulsates with more coin-op pleasures as Suzi Uki rides into town

Sumimasen for yet another month free from my hot slots, but now the redness has completely cleared up and the doctor says I can get straight back onto the streets. And so here I am, all rough and ready for action, and waiting with open legs to straddle the latest sticky side-shows to amuse and excite, in search of the ultimate pleasure experience.

The reduced space this month is

due to my insistence on squeezing in "Big Boy" Boardman and his rabbit tale. As you all know, I've always got time for big throbbing intrusions into my column. In fact, here come a few muscley men to whisk me away right now.

ROLLING THUNDER 2

Namco

Many years ago, before I'd found the delights of *Afterburner's* vibrating seat, there was a horizontal, platform cop game called *Rolling Thunder*. Well the cop with a shot is back to deal a bit more deathly justice in



Namco's *Rolling Thunder 2*. Of course the news of the return of this smart, suave, special agent Rolling Thunder soon had my attention. There's little that excites me more than an athletic young figure all

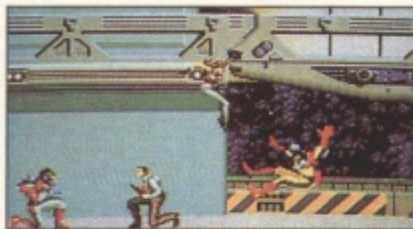

dressed up in a police uniform. But it seems the young man is spoken for, as accompanying him on this adventure is his busy partner Leila. Still,

THE SIMPSONS

Konami

As I travelled the ga-sens of Hong Kong, I couldn't help bumping into little Bart Simpson all the time. My, that little chap doesn't half try it on. I'd hardly taken off my leather boots (as is the custom when entering someone's house), than he was trying to get the whips and chains out. Anyway, the young lad needed some instruction, so who was I to deny him? The next thing I knew, he had me prostrate in front of his new four-seater.

The Simpsons special cabinet features four seats behind a large bench in front of a 26-inch TV-style cabinet. The controls for each play-

I'm not complaining, the more the merrier.

The action is set in that increasingly popular year of 199X, where communications satellites orbiting some countries have mysteriously been disabled. The two coppers are sent off on their way to find out just what

STRIKEFORCE

Midway

They're tall. They're strong. They're primed for optimum pleasure. Oooh. Unfortunately, they are also green (but who minds when the lights are off?). Yes, this collection of creatures are actually lizards from outer space. And you know what they say about lizards' tongues...

Midway's *Strikeforce* takes you to the planet of Mega-Star Apocalypse, where 22 human captives are being held. The Saurian lizard-men are using the people for slave labour and slowly turning them into reptiles which they hope to use to invade Earth. You control a muscle-bound marine



Big green men from outer space have captured 22 humans. Go in like Flint to rescue them from their captors.

infantryman (of which I've much experience) equipped with the latest, most lethal weaponry. It's just a shame that these lizard-men are equipped with the most lethal claw swipe around. Thankfully, though, you also get some big jetfighters kitted out with some powerful combat weapons.

The best blasting fun is had by grabbing a friend (preferably of the opposite sex) and getting them to play with you. Simultaneous action for all to see - it's always better in front of an audience. There are 22 Saurian planets to venture across, with you eventually ending up at the Mega-Star.

All this may sound like something you've played before, but take my word for it, there's no substitute for experience.





are housed within the bench, and look after the four older members of the Simpsons family. Your objective is to rescue Maggie (the baby) from the diamond thieves who kidnapped her when she swallowed the diamond they had just nicked. Each family member has his or her own moves, which adds greatly to the fun. Bart can skateboard people over, Homer splash dives on them, Marge vacuums them up, and Lisa whips enemies with her skipping rope (my sort of girl).

As always, the best fun is had with a group of people. In fact, playing on your own is very lonely. But this machine should be so popular, you won't have any trouble making a few friends on the seats. There's also an upright version available, but I prefer to do it sitting down.



is going on, and to put a stop to it. As the world falls apart around them, Leila and Albatross (madeupnames) encounter innumerable weird, menacing creatures. Most of them look as if they come from another planet, wearing red gloves over their odd-coloured wet suits. In fact, this game got me a bit wet too. There is just so much action in this game, you'll be reaching for a towel to soak up the sweat.

At the root of the problem is an organisation called GERDRA, your old enemy from the original game. It's all familiar stuff, which is just what I like because you know just where to go to get maximum pleasure.

BRIDE OF PIN-BOT

Williams

If Bugs' little birthday celebration didn't cure your twitchy fingers, then get your arms around *The Machine: Bride of Pin-Bot* – another great pinball game. As you smack the little balls around the table, the bride slowly comes to life before your eyes. The first shot up the Shuttle Ramp goes straight into her mouth, and she gobbles it up with pleasure. With a quick gulp, she soon opens her eyes to see who's tickled her fancy. And that someone should be you, as this is one of the most exhilarating machines around.

The whole table represents the bride's curvaceous body. If you manage to get your shiny balls onto any of her flashing erogenous zones, points galore are ready for the taking. A novel Multi-Ball mode doubles your (and her) pleasure, as you have to cope with two balls at once. Get both balls in her eyes and you could be in for a chance of getting this big girl away from her horrible husband Pin-Bot.

Up at the top-right corner, Pin-Bot keeps an eye on his bride and gives out extra bonuses if you manage to get your balls up her Shuttle Ramp when he asks. By the end of the day, I really envied this girl, there's even a shoot again option, depicted by a rocket with "One more time" written on it shooting up between her legs. Pass the yoghurt.

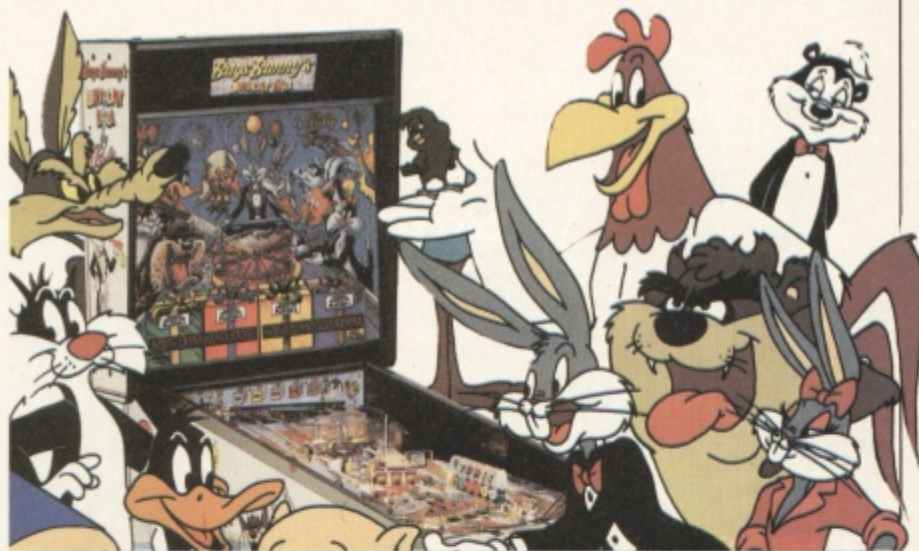

OL' BIG EARS

Julian "Big Boy" Boardman gets "hands-on" experience of one of Suzy's pin "balls"

Bugs Bunny is 50 this year. But the old fart still refuses to retire and he's keeping all his mates out with him. Their latest escapade is via a pinball machine. All your old favourites are here, from Foghorn Leghorn to the Tasmanian Devil and his missus. And who could forget Wile E Coyote, Tweety Pie and the Roadrunner?

One of the good things about this machine is the way you score, it is really quite unpredictable. Your first turn may give you 250K before you even get near a flipper, but the next ball may score no more than 10K before it sails in between your carrot-shaped flippers.

The scoring starts with Wile E Coyote's plunger skill shot that can award up to 500K, if you are damn lucky. It will then either drop through into the very innovative inverted play area or bounce around a few scoring bumpers and come flying out towards the flippers.

The inverted play area – the slope goes the opposite way to the rest of the table with a flipper at the bottom – gives the chance to knock out the watchdog targets and light the Big Score on the Daffy Duck two-way captive ball. Move the ball from one end to the other then back again to get 500K. From there you try to hit the ball up and out along the Tweety Slide for anything up to one million points. If you're unlucky enough for the ball to go to the side of the flippers, do not fear: a few hits in the right places mean that Speedy Gonzales's Kick-Out will come into operation, saving the ball and sending it flying towards the Looney Tunes target banks. If you manage to light every letter then you get a cool million.

As if that wasn't enough, if you are skilful enough to get the ball up the ramp and into the Tasmanian Devil's Shopping Spree then you can win anything from 25K up to a free ball.

But no pinball game is complete without a stupidly huge bonus, in this case 50 million. It all revolves around a skill shot to blow out the candles on the cake. Getting the ball in the right hole will blow out a random number of candles. If on your third ball you blow out nine candles then the 50 million bonus will be lit and you have ten seconds to get the ball back in the hole to win the 50 million. Nowhere near as easy as it sounds because ten seconds is not a long time when your ball decides to gently roll down the table and you get told to "Watch it!" if you attempt a tilt. I came close to getting the bonus a couple of times, my ball bounced out of the hole, but I have yet to actually see anyone do it.

Even when the last ball has whistled irrevocably past the flippers it is not over, then comes the Surprise Package. You can hit the left flipper to accept or the right flipper to decline and pass on to your opponent. The package can be a bonus of up to a million points for you, a penalty of a few thousand points, a gift of one million points to the next player, or the machine will swap your scores around. That can change the outcome of a game and it makes the machine all the more addictive.

With the sampled slogans from all your favourite cartoon characters, the excellently designed cabinet and a truly superb game design, it looks set to take the amusement halls, pubs and clubs by storm. The only things that stop me from playing it all the time are someone else getting there before me or the pub shutting. If you get a chance to play it, don't get tight about a mere 20p – Suzy Uki is never tight.

SUZY UKI'S HONG KONG TOP TEN HOT SLOTS

1. **Street Fighter II** (Capcom)
2. **Earth Defense Force** (Jaleco)
3. **Hot Shots** (Strata)
4. **Hat Trick Hero** (Taito)
5. **Cycle Warriors** (Tatsumi)
6. **Super Pinball Action** (Tecmo)
7. **Growl** (Taito)
8. **Columns** (Sega)
9. **Super Pang** (Mitchell)
10. **Cisco Heat** (Jaleco)

QuickShot[®]

by Bondwell

FOR YOUR *BEST SHOT!*



PYTHON 1 - QS 130F
BioGrip control and deluxe digital response plus high-speed auto-fire and dual triggers. Compatible with most video game systems.*



MAVERICK - QS 128F
8-direction, arcade-type control stick with two player select switch. Compatible with most video game systems.*



STARFIGHTER - QS 127
Far and away the most versatile remote controller, effective at 20 feet, compatible with most video game systems.*



PYTHON 3 - QS 135
Precision performance for Sega GENESIS 16-bit video game systems.



APACHE - QS 131
Fast action and BioGrip for maximum control. Compatible with Atari and Commodore game systems.



FLIGHTGRIP - QS 129F
High-speed auto-fire and 8-direction thumb-pads. Compatible with most video game systems.*

INSIST ON QUICKSHOT... THE GENUINE PIECE by Bondwell.

QuickShot[®]
25,000,000

JOYSTICKS SOLD WORLDWIDE

Available at most major department stores and computer dealers.

*Sega, Atari, Commodore, MSX and Amstrad

STICKY FINGERS

If there's one thing every games player should have (apart from a game), it's a joystick. Even in the depths of a so-called recession, joystick manufacturers are claiming that you've never had it so good. Multi-coloured, infra red, stopwatched, autofired, tea-making... Whatever you want, they've thought of it. But where do you start? It's a joystick jungle out there, so let RAZE guide you through

SHOOT-'EM-UP

Any joystick suitable for shoot-'em-ups should have fire buttons, and lots of 'em. Autofire is essential, where as turbo/rapid fire (which only sends a pulse of fire when a button is pressed) is always useful. Not all autofires operate at the same rate, so an adjustable one is even better.

Amiga/ST	IBM	Sega	Nintendo
SWIV	Xenon	Verytex	Cyberoid

ARCADE ADVENTURE

Comfort is the most important thing, as arcade adventures can often take hours to play. Easily accessible diagonals are also essential, for climbing ramps/ladders and jumping on the run.

Amiga/ST	IBM	Sega	Nintendo
James Pond	Prince of Persia	James Pond	Turtles

WRENCHER

The ultimate test of endurance. A short travel (moving the stick from left to right) is always an advantage, although some very springy tall joysticks also prove successful.

Amiga/ST	IBM	Sega	Nintendo
Daley's Oly. Chall.	Budokhan	World Cup Italia 90	Track+Field II

SIMULATION

Something comfortable for flying/driving long distances. The stick must also be very responsive for dogfights and chicanes. Shouldn't need wrenching as this leads to over compensation.

Amiga/ST	IBM	Sega	Nintendo
F-18A Interceptor	Jetfighter II	Super Monaco GP	Super Off-Road

THE TEST
Each of the joysticks was tested on four types of game: a shoot-'em-up, arcade adventure, wrencher and simulation. The test took a minimum of 30 minutes for each game, totally at least two hours varied play for each stick. The totally test time was over 60 hours.

THE RATINGS

DURABILITY:
Will it last till Boxing Day?

ERGONOMICS:
Does it feel right in your hand?

RESPONSIVENESS:
Does it do what you want, when you want it?

STREET CRED:
Will you be the envy of your friends?

OVERALL:
Is it all worth the asking price?

CRUISER MULTI-COLOUR

POWERPLAY ● £10.21

The long-running Cruiser series has gone multi-coloured. Anyone not familiar with their design will need to know that the base looks like a large foot with the toes cut off, the actual stick is positioned just forward of the heel and the two fire



buttons on either side at the front. The four suckers offer stability but it soon becomes very uncomfortable to use unless held in the palm of your hand. An unusual feature allows you to adjust the tension of the stick at the base, helping ease the strain on your wrist.

CRUISER MULTI-COLOUR

Shoot-'em-up: The lack of corners on the base confuses orientation.

Arcade adventure: Lack of corners made it difficult to have complete control in a game where it's essential.

Wrencher: Performed well on *DTOC*. Tension adjustment maximizes performance, and physically the stick held up well.

Simulation: The tight setting allowed for fine tuning of manoeuvres.

DURABILITY	●●●●
ERGONOMICS	●●
RESPONSIVENESS	●●●●
STREET CRED	●●●●
OVERALL	●●●●

SURESHOT STANDARD

SONMAX ● £11.19

This is a remarkably basic joystick jazzed up by a transparent base. It features one large, front fire button, angled towards you. The leaf-switch is unbelievably quiet, which often makes you wonder whether you've actually pressed it. Unlike the Cruiser, the curved shape doesn't hinder and the Standard fits nicely

in your palm. Four micro-switches do the business on directions, but make for an unusually long travel.

SURESHOT STANDARD

Shoot-'em-up: Fairly average. The long travel doesn't make short sharp moves very easy.

Arcade adventure: Behaves well because it is less susceptible to little twitches that could put you off course.

Wrencher: The loose nature of the stick allows for a lot of furious wagging.

Simulation: Not accurate enough for the fine operations required.

DURABILITY	●●●●
ERGONOMICS	●●●●
RESPONSIVENESS	●●●●
STREET CRED	●●●●
OVERALL	●●●●

STAR PROBE DELUXE

CHEETAH ● £14.99

The first of the four-button, auto-fire, jet-pilot type of joystick to come our way from Cheetah. It features two fire buttons on the base and two on the shaft. The metal shaft triggers eight micro-switches making it far more sensitive and less liable to wear than a stick with just four. Initially it feels a little tacky but a few hours play convinces you of its solidity.

STAR PROBE DELUXE

Shoot-'em-up: Hopeless. Far too loose to offer any accuracy of control.

Arcade adventure: Much the same story, often taking three or four attempts to get the right positioning.

Wrencher: Not much resistance to give yourself any injuries, should stand up to any hammering you give it.

Simulation: Poor. It takes a lot of hard work to get it to perform the way you want.

DURABILITY	●●●●
ERGONOMICS	●●●●
RESPONSIVENESS	●●
STREET CRED	●●
OVERALL	●●●●

DELTA JET

PRODUCT 2000 ● £9.95

The base is shaped a lot like the shuttle vehicle from the original Star

Trek series, and as such is pretty uncomfortable. On top of this is a micro-switched fire button, behind the button is a bulbous growth which does apparently hide the four directional micro-switches. Out of this lump comes a steel shaft that goes to the centre of an uncomfortable tapered square handle. A reasonable performer let down by its design.

DELTA JET

Shoot-'em-up: It doesn't improve your performance, but it goes nowhere near hindering it.

Arcade adventure: The loose, self-centring design is surprisingly useful.

Wrencher: I scored my best times on this joystick because of the aggressive self-centring. But will the nylon shaft take the strain...

Simulation: Gives quite a light touch which is what you need for gentle positioning of an aircraft.

DURABILITY	●●●
ERGONOMICS	●
RESPONSIVENESS	●●●●
STREET CRED	●
OVERALL	●●

CRYSTAL SEGA

POWERPLAY ● £13.26

Based on the much-loved – by the RAZE team anyway – Crystal. Well, I say based on but it is in fact identical, just changed to be compatible with the Master System (and coloured black to make it look cool). It performs superbly but my only complaint is that it would be nice to be able to switch buttons ONE and TWO around for left- and right-handed preferences.

CRYSTAL SEGA

Shoot-'em-up: One of the most accurate and responsive joysticks available today.

Arcade adventure: Again the accuracy, despite only having four micro-switches, shines through.

Wrencher: Feels a little spongy, but not supple enough to take the stress.

Simulation: Zooming around the race track was no problem with this little number.

DURABILITY	●●●●
ERGONOMICS	●●●●
RESPONSIVENESS	●●●●
STREET CRED	●●●●
OVERALL	●●●●

SX CHALLENGER

CONTRIVER ● £35.75

Infra red joysticks are fine in principle, but unlike some TV and video remotes, you can't just point this one anywhere and be sure of it working. You spend too much time ensuring the receiver will pick up the signals, which is a pity as the stick itself is a good one and highly-specified – it can even work on any machine, including the Mega Drive. The proliferation of fire buttons makes it ideal for either left- or right-handed people, and the fire buttons can be set up to either fire continuously or send out one shot at a time.

SX CHALLENGER

Shoot-'em-up: Reasonable and responsive enough for the average player.

Arcade adventure: Quite useful if you can manage to keep the signal going.

Wrencher: Responds well to gentle banging but durable enough to take the harder stuff.

Simulation: The big stick allows you to make the difficult sweeping movements.

DURABILITY	●●●●
ERGONOMICS	●●●●
RESPONSIVENESS	●●●●
STREET CRED	●●●●
OVERALL	●●●●

JETFIGHTER

QUICKJOY ● £13.95

This Chinese-manufactured stick has a hand grip that lives up to its name; it does indeed look like a jet-



fighter's control stick. There's an index finger fire button in front of the large head, which itself houses another fire button and the speed controls for each button's autofire. It

is designed solely for one-handed use as the base is geared to the optimum placement of the suckers rather than the unused hand.

JETFIGHTER

Shoot-'em-up: The response from the four micro-switches is a little sluggish.

Arcade adventure: The slow response can be worked to your advantage.

Wrencher: Worryingly flimsy and totally unusable as it chaffs your thumb after a while.

Simulation: A good, accurate response helped by the easy location of the switches.

DURABILITY	●●●●
ERGONOMICS	▶●●●●
RESPONSIVENESS	▶●●●●
STREET CRED	●●●●
OVERALL	●●●●

ARCADE POWER STICK

SEGA ● £34.95

This would be far more at home in an arcade than cluttering up your front room. It may be expensive, but the solid construction and impressive design justify the high price. Above each button is its MegaFire switch which enables autofire, the rate of which is variable by a slider. The shaft is very sturdy, with the round head allowing total accuracy. Like other Sega hardware, though, this is obviously overpriced. Even so, it's very impressive.

ARCADE POWER STICK

Shoot-'em-up: Very responsive and particularly useful with the MegaFire option.

Arcade adventure: No effort at all is required to get all those awkward diagonals.

Wrencher: The stick can handle it, but the positioning of the buttons can lead to wrist ache.

Simulation: This baby could practically guide you round the track on its own.

DURABILITY	●●●●●
ERGONOMICS	●●●●●
RESPONSIVENESS	●●●●●
STREET CRED	▶●●●●
OVERALL	▶●●●●

125+

CHEETAH ● £9.99

This leaf-springed effort from Cheetah, more innovators than mar-



ket researchers, should never have seen the light of day. It offers flimsiness next to tackiness and lack of control next to discomfort. In short, it stinks. For history buffs, Cheetah also produced a "Special" version for the Spectrum which featured a rotating shaft. It was supposed to be used in tank games etc, but sadly no software company utilised the unique feature.

125+

Shoot-'em-up: If you are not careful, you'll find yourself wandering all over the place.

Arcade adventure: If you manage to get through that small diagonal gap first time, you are very lucky.

Wrencher: Far too uncomfortable, and wouldn't last long anyway.

Simulation: Forget it.

DURABILITY	●●
RESPONSIVENESS	▶
ERGONOMICS	▶●●
STREET CRED	●●
OVERALL	●●

MICROJET

PRODUCT 2000 ● £10.99

This three-button aggressive looking jet pilot type stick is one of the better



Product 2000 designs. If you are a one-handed, suckered to the table type player then this could well be the stick for you.

There's an index finger trigger, a repeating thumb trigger and a single shot button just to the left of that, which will make it difficult to reach for left-handed players. The grip can be a little uncomfortable after a while, the design makes your palms sweat, and the base does not lend itself to being held at all.

MICRO JET

Shoot-'em-up: Good response and high level of accuracy.

Arcade adventure: Very easy to get through the tricky sections onscreen.

Wrencher: Too uncomfortable for long-term usage, also a little weak.

Simulation: Some coaxing and concentration will bring out reasonable results.

DURABILITY	●●●
RESPONSIVENESS	●●●●
ERGONOMICS	●●●●
STREET CRED	●●
OVERALL	●●●●

PC POWERPLAY

CHEETAH ● £24.99

Sadly another duffer from Cheetah. Firstly, the design seems to make it look the wrong way around; everyone who used it tried holding it with the fire buttons to the top instead of to the left. Secondly, this design is also very tacky, far too much red plastic to appeal to the average PC owner. And finally, it is of such low quality construction that even when calibrated it never stays central. And why so expensive?

PC POWERPLAY

Shoot-'em-up: Next to hopeless. Inconsistent feel to the stick.

Arcade adventure: Not enough accuracy to help the gameplay.

Wrencher: Uncomfortable handle will hurt your palm.

Simulation: The plane never goes where you want it to. (Does it ever?)

DURABILITY	●●
RESPONSIVENESS	●●
ERGONOMICS	—
STREET CRED	●
OVERALL	●

PC JOYSTICK

POWERPLAY ● £20.42

(£36.76 with joystick card)

No fancy frills or tackiness here, not even an inappropriate name, just a simple, straightforward buff-coloured joystick that matches the PC very nicely. The tight, solid construction make this one of the most reliable joysticks on the market – it's the only one RAZE ever uses on the PC. Two fire buttons, two axis adjusters and a compact stick that offers control in any situation.

IBM PC JOYSTICK

Shoot-'em-up: Not bad, but long travel.

Arcade adventure: Once you get used to the nuances of an analogue joystick, it performs reasonably well.

Wrencher: Comfortable grip and solid steel shaft make for a usable wrencher.

Simulation: Absolutely spot on. Any manoeuvre you like can be done with ease.

DURABILITY	●●●●
RESPONSIVENESS	▶●●●
ERGONOMICS	●●●●
STREET CRED	●●●
OVERALL	▶●●●

GUNSHOT II

PRODUCT 2000 ● £6.95

Just two pound more than the Gunshot with a couple of extras. Firstly, there's the essential autofire option, sensibly mounted at the front of the base. There's a trigger button too, which is a necessity with today's fast shoot-'em-ups. The base is in a diamond shape which makes it a little awkward to use as a handheld, and aesthetically it looks terrible. Cheap and unappealing – but then so's a Citroen 2CV and look how many people bought those!

Shoot-'em-up: Performs well if all you want is left, right and fire.

Arcade adventure: Response is slow due to the long travel and loose diagonals.

Wrencher: Tough, but the travel means a very sore shoulder.

Simulation: Too loose to use in dogfights where all the directions are constantly accessed.

DURABILITY	●●●
ERGONOMICS	●●●
RESPONSIVENESS	●●
STREET CRED	●●
OVERALL	●●●

STARFIGHTER QUICKSHOT ● £35.99

Another infra red offering, but this time from the BMW of the joystick manufacturers. This package comes with TWO remote joypads, one receiver and is compatible with Amiga, Atari ST, Sega, Nintendo, the lot (except PC). Each controller has two fire buttons, which may prove a restriction on complex Mega Drive games. There's autofire, power on/off (four AAA size batteries), a two-way button for select and start and a slow motion switch for those tricky moments. Its range is 20 feet, which is significantly better than any other infra red controller. Ideal for folks with more than one machine.

STARFIGHTER

Shoot-'em-up: Nicely responsive, but watch where your thumb is going.

Arcade adventure: Four-way controllers are never accurate enough but this does well.

Wrencher: Hopeless for *DTOC* but quite good on *World Cup Italia 90*.

Simulation: A surprising amount of accuracy: very usable.

DURABILITY	●●●●●
ERGONOMICS	●●●●●
RESPONSIVENESS	●●●●●
STREET CRED	●●●●●
OVERALL	●●●●●

NI-5 QUICKJOY ● £15.95

Undoubtedly the better handling of the two Nintendo sticks, without all the nice lights and multi-fire buttons.



The NI-5 still has the thumb and trigger fire buttons, variable speed autofire but just two LED indicators. However, there are only six micro-switches in there, but this doesn't

affect its performance. It's more convenient to use as a hand-held, as opposed to the table-top N-Pro. Although not as visually appealing as the N-Pro, at four quid cheaper, I'd recommend this to a Nintendo owner every time.

NI-5

Shoot-'em-up: Dial-a-speed firing makes shooting the bad guys *dead easy*.

Arcade adventure: Precision movements are very easy to get out of this hand-held.

Wrencher: May not hold up to the punishment.

Simulation: Again, precision is the key, and this baby comes up trumps.

DURABILITY	●●●●●
ERGONOMICS	●●●●●
RESPONSIVENESS	●●●●●
STREET CRED	●●●●●
OVERALL	●●●●●

N-PRO QUICKJOY ● £19.95

A very tidy looking joystick, with a few extra features to justify the high price. The first thing that strikes you is the front-mounted LED response indicator – which tells you whether



N-PRO

Shoot-'em-up: Ideal for a firing frenzy, with very responsive buttons if you don't fancy autofire.

Arcade adventure: Easy to get the diagonals, although not too accurate.

Wrencher: Lasted well, but creaks a bit.

Simulation: A feeling of total control with the big stick.

DURABILITY	●●●●●
ERGONOMICS	●●●●●
RESPONSIVENESS	●●●●●
STREET CRED	●●●●●
OVERALL	●●●●●

you've pressed button A or B. The fire buttons, which are mounted in the main handgrip, come complete with an autofire option, making the whole thing very similar to the old Quickshot II. (RIP). However, this buff beauty comes with ten "competition quality" micro-switches to ensure it lasts.

COMPETITION PRO STAR POWERPLAY ● £18.34

A very striking stick for the Master System, especially as the handle and fire buttons are chrome-plated, er, sprayed with a tacky silver paint.



(Ideal for vain gamers who like looking at themselves while they play.) Includes autofire and a slow motion feature – only slightly more than the boring Sega pad. The autofire is extremely rapid, so you won't even need Sega's rapid fire module. The robust exterior conceals an even more robust interior, complete with top quality micro-switches.

COMPETITION PRO STAR

Shoot-'em-up: The extra large fire buttons combine with the rapid fire to make it ideal.

Arcade adventure: The awkward diagonals have never been a problem for this classic design.

Wrencher: You have to do some pretty abnormal things to get this to break.

Simulation: Can handle the most delicate of movements as well as sudden jolts.

DURABILITY	●●●●●
ERGONOMICS	●●●●●
RESPONSIVENESS	●●●●●
STREET CRED	●●●●●
OVERALL	●●●●●

ZIPSTIK SUPER PRO POWERPLAY ● £14.25

This is without doubt one of the office favourites – it not only looks



good, it also performs well under pressure. Although suited more to hand-held use (no suckers), the small footprint means it doesn't tilt all over the place when on a table top. The two yellow buttons at the front of the base are square in shape with circular indentations, and the responsive click when pressed ensures you can safely rest a thumb on them without setting them off.

ZIPSTIK SUPER PRO

Shoot-'em-up: No-one in the office has got further on *SWIV* with any other joystick.

Arcade adventure: Those diagonals are a little too easy to fall into.

Wrencher: Your arm will break before the Zipstik does.

Simulation: *Interceptor* was no match for the Zipstik, especially in dogfights with the MiGs.

DURABILITY	●●●●●
ERGONOMICS	●●●●●
RESPONSIVENESS	●●●●●
STREET CRED	●●●●●
OVERALL	●●●●●

SUPER BOARD QUICKJOY ● £17.95

If there's one thing that annoys me more than people not supplying plugs on appliances, it has to be companies that don't stick free bat-



teries in a product that needs them. That said, the stopwatch isn't really worth spending 50p on batteries for – can you think of a use for it? The fire buttons are also a moot point. Although there are numerous buttons on both the base and the shaft, you can't actually use both sets simultaneously! The speed control on the autofire is also a bit redundant as the firing doesn't seem to vary. Above all, the thing's far too big, taking up as much room as a console on its own!

SUPERBOARD

Shoot-'em-up: Quick movement is impossible with this giant of joysticks.

Arcade adventure: Diagonals? Where?

Wrencher: Tough, but a real beast to control.

Simulation: Probably best suited to sims where you can pretend you're holding onto a full-size throttle.

DURABILITY	●●●●
ERGONOMICS	●●●●
RESPONSIVENESS	●●●●
STREET CRED	▶●●●●
OVERALL	●●●●

SUPERJET 1

PRODUCT 2000 ● £12.95

A very striking joystick. The novel design, shape and colouring really make it stand out. The base is designed to fit comfortably in the hand while the suction cups make it an ideal table-top stick. As well as two buttons on the base, the shaft has four others. The micro-switches used inside carry a 18 months warranty, although you probably won't need it. A great all-round stick at a super price.

SUPER JET 1

Shoot-'em-up: Excellent performance, with no shortage of buttons (including autofire).

Arcade adventure: In hand-held use, this stick is very precise.

Wrencher: Even the Boardman stomp couldn't phase this sucker.

Simulation: It ain't call Superjet for nothing.

DURABILITY	●●●●
ERGONOMICS	●●●●
RESPONSIVENESS	●●●●
STREET CRED	▶●●●●
OVERALL	●●●●

GUNSHOT 1

PRODUCT 2000 ● £4.95

A joystick for under a fiver? You'd better believe it. In fact this stick looks uncannily like the much loved (and broken) Quickshot of



yesteryear. Just two buttons, one on the base and one on the top, and four dodgy suckers. Well, you get what you pay for...

GUNSHOT 1

Shoot-'em-up: Awkward and uncomfortable for constant jerky movements.

Arcade adventure: Won't sit on the table top and the diagonals are a bit loose.

Wrencher: Designed before a Daley Thompson game – nuff said.

Simulation: Hard to fire and fly at the same time.

DURABILITY	▶●●●
ERGONOMICS	●●●●
RESPONSIVENESS	●●●●
STREET CRED	▶●●●
OVERALL	▶●●●

SEGA POWERMATE

TEQNICHE ● £16.99

If you can't save up for Sega's Power Stick, then this is the next best thing. Personally, I think this robust table-top stick looks a lot slicker than the Sega's black stick, although the light colour doesn't really complement the Mega Drive. It features a slow motion control (which acts like pausing and unpausing the game very quickly), and two extra buttons on top of the SELECT, START, etc for a mysterious "future use". The Turbofire buttons

are all adjustable, and come with lights to indicate their operation. The stick feels damn good on most games, the only drawback being the design and placement of the much used button A. This is too small and too far away from the normal size B and C buttons. Great value compared to Sega's expensive equivalent.

SEGA POWERMATE

Shoot-'em-up: Loads of firing options, although button A is too small.

Arcade adventure: Superbly accurate and a pleasure to use for hours on end.

Wrencher: No harsh cracks from the short shaft which is suited for rough arcade games.

Simulation: Bang goes the old excuse, "it was the joystick's fault".

DURABILITY	●●●●●
ERGONOMICS	●●●●
RESPONSIVENESS	●●●●●
STREET CRED	▶●●●●
OVERALL	▶●●●●

MEGA JET

PRODUCT 2000 ● £19.95



MEGA JET

Shoot-'em-up: Brilliant firing mechanism for this type of stick.

Arcade adventure: Ideally suited to hours of directional use.

Wrencher: A bit cumbersome, but it lasted.

Simulation: The big shaft adds to the "holding onto the throttle, zooming around the skies" feeling.

DURABILITY	●●●●
ERGONOMICS	●●●●
RESPONSIVENESS	●●●●●
STREET CRED	●●●●●
OVERALL	●●●●

Another very striking stick with a large base and an angled front with a timer in it (complete with FREE battery!). Street cred rating goes through the roof as the Mega Jet boasts seven LEDs – four directions, two fire buttons and one saying if the timer is on. The five fire buttons (two base, three shaft) are extremely responsive and come with autofire. Only one query: why the gross red base?

STING-RAY

LOGIC-3 ● £14.99

The Sting-Ray is a dedicated handheld stick. (Try balancing this on a table top and it would probably fall in your coffee.) It's a lightweight stick and is designed with comfort in mind. The handgrip is moulded to fit comfortably in a normal size hand, with the trigger button ideally placed



to accommodate the index finger. Similar to Konix's top-selling Navigator, the Sting-Ray looks and plays a lot better. If you like this type of design, then you'll do no better than the Sting-Ray.

STING RAY

Shoot-'em-up: Lots of intricate sweeping in and out of enemies was relievingly simple.

Arcade adventure: With a name like Sting-Ray, it was ideal for James Pond's underwater world.

Wrencher: A short shaft means a long life.

Simulation: Land, sea or air, this is one stick that can cope.

DURABILITY	●●●●●
ERGONOMICS	●●●●●
RESPONSIVENESS	●●●●●
STREET CRED	●●●●●
OVERALL	●●●●●

EXTERMINATOR CHEETAH ● £6.99

Cheetah seem to have cornered the market on cheap and not-too-cheerful joysticks. The Exterminator has



two buttons, one on the base and one on the top of the shaft. It's extremely uncomfortable to use as a hand-held stick and is very awkward to use on the table top. The long shaft doesn't inspire confidence in its life span, although the fire button on the base was the first thing to pack up with us. Still, at £6.99 what are you expecting?

EXTERMINATOR

Shoot'em-up: No autofire – unless it breaks down, like ours, which wouldn't stop firing!

Arcade adventure: Too long a shaft to quickly turn and obtain diagonals.

Wrencher: Decathlon fodder.

Simulation: Not sensitive enough – you'll soon find yourself out of control.

DURABILITY	●●
ERGONOMICS	●●
RESPONSIVENESS	●●
STREET CRED	●
OVERALL	●●

SEGA POWER PAD

TEQNICHE ● £8.99

This pad's shape is identical to that of the original Mega Drive pad. The only additions are three turbo buttons and a slow motion switch



underneath (which is nothing more than a rapid fire pause). The START button has been moved to a more

central position between the four-way controller and the buttons. It feels heavier in the hand than the original and the buttons, in a garish orange and blue, don't lend themselves to the black styling of the Mega Drive and official Sega products. Apart from that it is identical in every way to the original controller. The only question is, do you want to pay £8.99 for the very useful turbo buttons and a slightly irrelevant slow motion?

SEGA POWER PAD

Shoot'em-up: Accurate and responsive enough for highly skillful players.

Arcade Adventure: Four-way controllers are notoriously difficult for getting those swift diagonal moves with any accuracy.

Wrencher: Your thumb soon becomes very tired and sore.

Simulation: Takes you quite adequately around the track, but not as well as some more expensive controllers.

DURABILITY	●●●●
ERGONOMICS	●●●
RESPONSIVENESS	▶●●●
STREET CRED	▶●●
OVERALL	▶●●●

MACH 1 CHEETAH ● £12.99

The autofire switch at the back of the stick fell off straight away – not a good way to start. Next to go was one of the directions, but not before a couple of people pinched their hands in the gap where the shaft meets the base. I'm sure Cheetah have put this stick through much rigorous testing, but flaws like this make you wonder.

MACH 1

Shoot'em-up: Too easy to move in directions you don't want to go.

Arcade adventure: Deft movement and diagonals are out of the question.

Wrencher: Broke after a few tough *DTOC* events.

Simulation: The angled shaft encourages you to pull down when you don't want to.

DURABILITY	▶
ERGONOMICS	●
RESPONSIVENESS	▶●●
STREET CRED	●●
OVERALL	▶●●

MAVERICK 1 QUICKSHOT ● £14.99

The Maverick is one of a series of Quickshot sticks compatible with both the Amiga, ST and Master System. The unit consists of a large base with two fire buttons, an autofire selector and the system switch. Also on the ample base is a switch that allows you to use the joystick from either port, which saves on wear and tear by plugging into both ports at the same time and just switching between them. A very sensible stick, giving the games player just what he needs, no more and no less.

MAVERICK 1

Shoot'em-up: Accurate movement and a very fast autofire.

Arcade adventure: Just how a joystick should be. Easy to use and comfortable in the hand.

Wrencher: Again, a short shaft provides the maximum performance.

Simulation: Very responsive, although it's table-top only.

DURABILITY	●●●●●
ERGONOMICS	●●●●●
RESPONSIVENESS	●●●●●
STREET CRED	●●●●
OVERALL	●●●●●

FLIGHTGRIP 1 QUICKSHOT ● £8.99

Compatible with the Master System, Amiga and ST, the FlightGrip is a hand-held contraption, more in line with a joypad than a stick. It features two hand grips connected to make it like a very small bike handlebar. Both fire buttons are offset right from the centre, one for the

FLIGHTGRIP 1

Shoot'em-up: Many lives will be lost getting used to it.

Arcade adventure: Very hard to reach those diagonals using the awkward thumb pad.

Wrencher: Broken thumb, yes. Good performance, no.

Simulation: It's supposed to put you in the driver's seat, but you'll be crashing before long.

DURABILITY	●●●●
ERGONOMICS	●●●●
RESPONSIVENESS	●●●●
STREET CRED	●●●●
OVERALL	●●●●

STIK BITZ

★ Cheetah have some weird novelty sticks in development. Stick X (£14.99), the stick with no name, has 18 months of development behind it. It sits in the palm of your hand and detects the movement of the hand for the directional control.

★ The Turbofighter is a yoke stick with two fire buttons and autofire. It comes with a clamp to stick it to the table and sells at a whopping £49.99.

★ One of the newest sticks to be launched is The Bug (£14.99). Compatible with Nintendo, Sega, Atari and Commodore, it fits in your hand and has a small directional controller on the top.

★ You've heard of the Turtles (£9.99), well now Cheetah are bringing out the Tortoise. The idea is to put your hand on the stick's back and rock it in the direction you want to go.

★ Cheetah have a stick coming out called The Knob – nuff said.

★ Now for the weirdest stick ever, the Aeroskate. You stand on a skateboard and use balance and aggression to control your onscreen character; firing is done from a hand-held unit. It has yet to be released, but Cheetah hope for a price between £25-35. Titus are already working on some software for it, and Cheetah hope more companies will follow suit.

★ In America, the Game Boy has already got its first joystick. Yes, it's totally true. The stick is a normal size and plugs straight into the Boy. Although what the point of having a full-size joystick with a hand-held console is, we just don't know.

index finger and the other for the thumb. Next to the thumb button, offset left of centre, is an eight-way thumb control pad. The stick is very light and comfortable to hold, feeling like some gadget from Star Trek. At £8.99 it's a great substitution for a Sega joypad.

Quickjoy

Joysticks

EUROPE'S TOP SELLING RANGE



SV.120 JUNIOR STICK
Twin Fire Buttons.
Hand Held
£ 5.95



SV.401-SG Fighter
For Sega
6 Microswitches
Autofire
L.E.D. Function
Indicators.
£14.95

SV.125-SUPERBOARD
10 Microswitches
Digital Stopwatch
Autofire.
£17.95



SV.126-JETFIGHTER
6 Microswitches.
New Pilot Grip
Autofire.
£13.95



SV.127-TOP STAR
Steel Shaft
Microswitches
Autofire
£23.95



SV.124-TURBO
6 Microswitches.
Autofire.
£8.95



SV.128-MEGABOARD
8 Microswitches
Stopwatch &
Countdown Timer
Autofire.
£24.95



SV.119-JUNIOR
Twin Fire Buttons.
£4.95



II PILOT



£6.95

SV.122

SUPERCHARGER



£9.95

SV.123

M6 IBM PACK



£29.95

SV.202/3

M5 FOR IBM PC.



£17.95

SV.201

QUICKJOY JOYSTICKS. Leading in design, technology and choice. Check out the range and features. Buy with confidence.

*Now available from Selected Branches of . . .



WH SMITH

John Menzies

BOOTS

Virgin

Selfridges

Hamleys

Software PLUS

. . . and all good computer dealers.



Unit 27 Northfield Industrial Estate, Beresford Avenue, Wembley, Middlesex HA0 1NU England.

Telephone: 081-900 0024

Facimile: 081-903 6625

RAZE Crew

Grab a piece of the action. If you're stuck in Bognor Regis or Stow-on-the-Wold, there's no need to sulk. Get yourself kitted out and join the fun!

CONSOLE ACCESSORIES

improve the game playing:

GAMEBOY MAGNIFIER

brings the action closer to you. 2x power magnification makes viewing easier, more fun **OFFER 7.14**

GAMELIGHT

lets you play your Game Boy in the dark. Improves screen visibility and contrast. Great for Nintendo at night! **OFFER 10.21**

GAME BOY AMPLIFIER

Turn up your Game Boy! Micro-amp gives you total volume control. Stereo speakers surround you with the sounds of Nintendo. **OFFER 13.27**

GAME BOY CLEANING KIT

OFFER 10.21

LYNX COMMS LINK CABLE

OFFER 7.14

LYNX CAR POWER ADAPTOR

OFFER 10.21

LYNX KIT CASE

carries Lynx machine, 12 games, car adaptor & power supply, survivor and batteries (carrying handle & optional strap) **OFFER 18.31**

LYNX POWER SUPPLY

OFFER 13.27

LYNX POUCH

carrying pouch that can hold Lynx machine & several games **OFFER 10.36**

LYNX SCREEN GUARD/SUN VISOR

protects your Lynx machine from sun and from being scratched & damaged **OFFER 6.12**

LYNX CLEANING KIT

OFFER 10.21

MEGADRIVE CLEANING KIT

OFFER 10.21

ZY-FI 2 x 3 WAY STEREO SPEAKERS & POWER SUPPLY UNIT

OFFER 41.71

THE MINISTRY OF CONSOLES

Can't find the console of your choice in your local shop? Don't panic! Order it straight from the worlds best console mag. All consoles offered are UK versions. All discounted prices include VAT and P&P.

NINTENDO CONTROL DECK	incl console, 2 controllers, Super Mario Bros game	OFFER 79.00
NINTENDO MUTANT MACHINE	incl console, 2 controllers, Teenage Mutant Hero Turtles gamepack, poster	OFFER 79.00
NINTENDO DE LUXE SET	incl console, 2 controllers, R.O.B., Zapper (light gun), Super Mario Bros & Duck Hunt games pack	OFFER 148.00
SEGA MASTER SYSTEM	incl console, 2 joypads & Super Hang On	OFFER 79.00
SEGA MASTER PLUS + MOONWALKER	incl console, 2 joypads, light phaser, Moonwalker	OFFER 97.00
SEGA MASTER SYSTEM PLUS + GOLDEN AXE	incl console, 2 joypads, light phaser, Golden Axe	OFFER 97.00
SEGA MASTER SYSTEM PLUS	incl console, 2 joypads, light phaser, Super Hang On	OFFER 97.00
SEGA SUPER SYSTEM	incl console, 1 joystick, light phaser, 3D glasses, Super Hang On & Missile Defense	OFFER 127.00
SEGA MEGA DRIVE	incl console, 1 joystick, Altered Beast	OFFER 189.00
SEGA MEGA DRIVE + WORLD CUP ITALIA '90	incl console, 1 joystick, World Cup Italia '90	OFFER 150.00
SEGA MEGA DRIVE + MOONWALKER	incl console, 1 joystick, Altered Beast, Moonwalker game and video	OFFER 190.00
COMMODORE C64GS GAMES CONSOLE	incl joystick and ROM cart with 4 titles: Flimbo's Quest, Fiendish Freddy, Klax, Int. Soccer	OFFER 61.29

HANDHELDS:

ATARI LYNX	without game cart and Comlynx cable	OFFER 77.00
	with Comlynx cable	OFFER 97.00
	with Comlynx cable and California Games cart	OFFER 127.00
NINTENDO GAMEBOY	incl console, earphones, comms link, Tetris games pack, batteries	OFFER 67.00
GAMATE	incl console, stereo headphones, manual, Gamate game card & batteries	OFFER 57.00

EXCRUCIATINGLY GOOD GAME CARTS!

All the games listed are all UK versions and have definitely been released (honest!). Give us a call on 0584 875851 for latest release news.

LYNX	CALIFORNIA GAMES	OFFER 26.00	SEGA	INDIANA JONES	OFFER 26.00
LYNX	MS PACMAN	OFFER 26.00	SEGA	JOE MONTANA	OFFER 26.00
LYNX	PAPERBOY	OFFER 26.00	SEGA	MICKEY MOUSE	OFFER 22.00
LYNX	RAMPAGE	OFFER 26.00	SEGA	PAPERBOY	OFFER 26.00
LYNX	ROBO SQUASH	OFFER 26.00	NINTENDO	BAYON BILLY	OFFER 32.00
LYNX	RYGAR	OFFER 26.00	NINTENDO	DONKEY KONG CLASSICS	OFFER 18.00
LYNX	SHANGAI	OFFER 26.00	NINTENDO	GHOSTBUSTER II	OFFER 32.00
GAME BOY	AMAZING SPIDERMAN	OFFER 18.00	NINTENDO	PINBOT	OFFER 26.00
GAME BOY	BALLOON KID	OFFER 18.00	NINTENDO	PROBOTECTOR	OFFER 26.00
GAME BOY	KWIRK	OFFER 18.00	NINTENDO	SNAKE RATTLE AND ROLL	OFFER 22.00
GAME BOY	REVENGE OF THE GATOR	OFFER 18.00	NINTENDO	SOLAR JETMAN	OFFER 26.00
GAME BOY	WIZARDS AND WARRIORS	OFFER 18.00	NINTENDO	STEALTH ATF	OFFER 26.00
MEGA SEGA	AFTER BURNER 2	OFFER 32.00	NINTENDO	SUPER OFF ROAD	OFFER 22.00
MEGA SEGA	ALTERED BEAST	OFFER 32.00	NINTENDO	TEENAGE MUTANT HEROES	OFFER 32.00
MEGA SEGA	DYNAMITE DUKE	OFFER 32.00	NINTENDO	WORLD WRESTLING	OFFER 32.00
MEGA SEGA	ISHIDO	OFFER 32.00	CBM CART	BEAST	OFFER 18.00
MEGA SEGA	JAMES POND	OFFER 36.00	CBM CART	NAVY S.E.A.L.S.	OFFER 18.00
MEGA SEGA	MICKEY MOUSE	OFFER 36.00	CBM CART	NINJA REMIX	OFFER 18.00
MEGA SEGA	MONSTERS LAIR	OFFER 32.00	CBM CART	PANG	OFFER 18.00
MEGA SEGA	MOONWALKER VIDEO & GAME	OFFER 32.00	CBM CART	PLOTTING	OFFER 18.00
MEGA SEGA	PGA TOUR GOLF	OFFER 36.00	CBM CART	TOKI	OFFER 18.00
MEGA SEGA	STRIDER	OFFER 42.00	AMST CART	DICK TRACY	OFFER 26.00
SEGA	ALTERED BEAST	OFFER 32.00	AMST CART	NAVY S.E.A.L.S.	OFFER 22.00
SEGA	CYBER SHINOBI	OFFER 26.00	AMST CART	PANG	OFFER 22.00
SEGA	GAUNTLET	OFFER 26.00	AMST CART	PLOTTING	OFFER 22.00
SEGA	HANG ON	OFFER 10.00	AMST CART	S.C.I. (OCEAN)	OFFER 22.00
SEGA	HEAVY WEIGHT CHAMP	OFFER 22.00	AMST CART	TOKI	OFFER 22.00
SEGA	IMPOSSIBLE MISSION II	OFFER 26.00	AMST CART	WILD STREETS	OFFER 26.00

SOFTWARE MEGA DEAL

If you wish to order any software that is currently available, please use the following special offer discount table to calculate our offer price using the recommended retail price as quoted on the software houses adverts.

RRP	SAVE
£2.99-£4.99	0.50
£5-£6.99	1.00
£7-£10.99	2.00
£11-£16.99	3.00
£17-£21.95	4.00
£22-£29.99	5.00
£30+	6.00

DISCOUNT LINE

Please phone

0584 875851

between 9am and 5pm and ask for DISCOUNT HOTLINE and we will give you availability and release dates for your software order.



STEP INTO THE FUTURE WITH **ELECTRO GAMES**



**MANY OTHER
FAVOURITES & NEW
RELEASES AVAILABLE
RING FOR DETAILS.**

THE SPECIALISTS
IN CONSOLES & GAMES
TEL/FAX: 081 530 8246
MON-SUN 10AM-7PM

**ALL MACHINES
CARRY A ONE
YEAR GUARANTEE
ETC...**

SEGA MEGADRIVE
PAL£130.00
WITH FREE GAME£155.00
SCART WITH FREE GAME...£155.00
UK/JAP CONVERTER£15.00

**NINTENDO
SUPER FAMICOM**
SCART£299.00
MAGAZINE£8.00

GAMEBOY
GAMEBOY DELUXE£69.00
LIGHTBOY£20.00

TOP TEN £30-£40
1, MIDNIGHT RESISTANCE
2, AIRWOLF
3, VERY TEX
4, MICKEY MOUSE
5, GYNOUG
6, HELLFIRE
7, MAGICAL HAT
8, JOHN MADDENS
9, WRESTLE BALL
10, AIR BUSTERS

TOP FIVE £45-£60
1, DARIUS TWIN
2, HOLE IN ONE
3, MARIO
4, PILOT WINGS
5, ULTRAMAN

GAME GEAR
GAME GEAR
+ 2 GAMES£155.00

TOP TEN £25
1, W.W.F.
2, R-TYPE
3, BUBBLE BOBBLE
4, MICKEY MOUSE II
5, WHEEL OF FORTUNE
6, MERCENARY FORCE
7, BURAI FIGHTER
8, CAT RAP
9, FISH DOOD
10, F1 ACE (with four player adaptor)

TOP FIVE £25.00
1, SHINOBI
2, MICKEY MOUSE
3, CHASE H Q
4, WONDERBOY
5, MONACO G.P.

**TRADE
TO
UK/EUROPE**

**RETAIL MAIL
ORDER
ALL WELCOME**

**ELECTRO GAMES
2 OVERTON DRIVE
WANSTEAD
LONDON
E11 2NJ**

● EXCELLENT SERVICE

● FAST DELIVERY

C/CARD NO:
NAME
ADDRESS.....
.....
.....
TEL.....
EXP DATE.....
SIGNATURE.....

GAME/MACHINE	PRICE

CARRIAGE £1 GAMES/£4 CONSOLES
CHEQUE
ACCESS/VISA
POSTAL ORDERS

TOTAL £.....

A NEW BREED OF HIRO

BLAST OUT THE NEIGHBOURS WITH A JVC COMPACT DISC

Thanks to Gremlin, we are back in that land of obvious names, where Hiro tries to defeat Havok who sends out Cannonfodder the soldier to try and defeat him. All this happened because a bloke called Ohsorrylads'vedoneitagain smashed the sword and the son of the original hero, Hiro, called Hiro Hiroson hopes to follow in his father's footsteps by retrieving the bits of the sword and beating Havok at his own game by causing a lot of trouble, or havoc, all to save a nation of people collectively known as the Jeezwe'llbesogratefulifyousaveus in the land of Thraxx.

Anyway, the point is that those green people at Gremlin were so happy that we gave them the much sought after RAZE Rave for their superb product Switchblade II, they just fell at our feet and begged us to run a competition - er, well, sort of. So we ummed and we ahhed - after all there are a lot of demands on our competition space - but we eventually gave in after they promised us loads of free booze next time we visited their huge Sheffield headquarters (which are so big, they have their own postal district - right, Mr Gremlin?).

They've generously donated one of those nice big JVC ghetto-blasters with a CD player, radio, cassette recorder, remote control, foot massager and teasmade. (OK, so I lied about the radio.)

Just answer these questions, fill out the form, and send the whole lot off to I want to be called "Cleverbugger", RAZE, Unit 3, 7 Back Street, Trowbridge, Wiltshire BA14 8LH.



RAZE

NEXT MONTH

POWER CAN NEVER BE GIVEN, IT MUST BE TAKEN

Take yours on...

JUNE 27

RAZE - Where the real power lies

QUESTIONS

- Which Motorway goes through Sheffield and on to Leeds?
 - A. M4
 - B. M1
 - C. M11
- Who fought at the Alamo and had a knife named after him?
 - A. John Wayne
 - B. Davy Crockett
 - C. Jim Bowie
- Switchblade is the American name for what?
 - A. Roller Coaster
 - B. Flick knife
 - C. That really tacky comb that looks like a flick knife and always fools the teachers.

HIRO APPLICATION

I promise to buy *Switchblade II*, which is after all the whole point of this over-hyped competition, but may forget in which case I'd like the JVC ghetto-blasters in which to drown my sorrows.

1 A B C **2** A B C **3** A B C

Name.....

Address.....

Postcode.....Shoulder size.....

Entries must be received by June 27 to avoid being called Stupidnitwhoforgottopostit.

WHIZZ-KID GAMES

0622 766010 MAIL ORDER HOTLINE

MEGADRIVE STOCK CLEARANCE

HUNDREDS OF GAMES
AT REDUCED PRICES

**BASKETBALL
GAIN GROUND
RASTAN SAGA
DJ BOY
CRACKDOWN
ESWAT
FATMAN
HARD DRIVIN'
AXIS FZ
ATOMIC ROBOKID
DYNAMITE DUKE
MOONWALKER**

ANY OF THE ABOVE
NEW JAPANESE GAMES
ONLY £25.00 EACH

ANY THREE OF THE ABOVE
NEW JAPANESE GAMES
ONLY £60.00

*WE WANT YOUR
OLD GAMES
PHONE FOR OUR
PART EXCHANGE
PRICE LIST*

WHOLESALE,
MAILORDER,
RETAIL AND
USED GAMES

UNIT 9, MID KENT
SHOPPING CENTRE,
ALLINGTON, MAIDSTONE,
KENT, ME16 0XX.
0622 766010

22 STATION SQUARE
PETTS WOOD
KENT
0689 827816

90 HIGH STREET
SIDCUP
KENT
081 300 0990

166 HIGH STREET
BECKENHAM
KENT
081 650 1205

VISIT OUR NEW VIDEO GAME WAREHOUSE

UNIT 9
MID KENT
SHOPPING CENTRE
ALLINGTON
MAIDSTONE
KENT
ME16 0XX

3 SALES LINES

COMPUTERISED
ORDERING SYSTEM

5000 GAMES
IN STOCK

FREE PARKING

2 MIN FROM M20
JUNCTION 5

*THOUSANDS OF
NEW AND USED
GAMES IN STOCK*

GAMEBOY

TOP 10	
1 ROBOCOP	25.00
2 GREMLINS II	25.00
3 GHOSTBUSTERS II	25.00
4 CHASE HQ	25.00
5 PIPE DREAM	25.00
6 DUCK TALES	25.00
7 CHESSMASTER	25.00
8 FINAL FANTASY	30.00
9 POWER RACER	25.00
10 ISHIDO	25.00

NEW GAMES	
BATTLE BULL	25.00
BEETLEJUICE	25.00
BUGS BUNNY II	25.00
BURDAI DELUXE	25.00
CURTIS STRANGE GOLF	25.00
HARMONY	25.00
KUNG FU MASTERS	25.00
MEGA MAN	25.00
OPERATION C	25.00
POWER MISSION	25.00
R-TYPE	25.00

USED GAMES		
TITLE	NEW	USED
BATMAN	25.00	18.00
DOUBLE DRAGON	20.00	15.00
BUGS BUNNY	25.00	18.00
BASES LOADED	25.00	18.00
TENNIS	20.00	15.00
GOLF	20.00	15.00

SEGA SYSTEM

TOP 5	
1 MICKY MOUSE	29.95
2 GAUNTLET	29.95
3 INDIANA JONES	29.95
4 SHINOBI WORLD	29.95
5 SUPER MONACO	29.95

NEW GAMES	
IMPOSSIBLE MISSION	29.95
PAPERBOY	29.95
JUNGLE FIGHTER	29.95
SUBMARINE ATTACK	29.95

USED GAMES		
TITLE	NEW	USED
AFTERBURNER	29.95	14.00
CALIFORNIA GAMES	29.95	19.00
DOUBLE DRAGON	29.95	19.00
OUT RUN	29.95	19.00
AERIAL ASSAULT	29.95	22.00
TIME SOLDIERS	29.95	19.00
VIGILANTE	29.95	19.00

MEGADRIVE + GAME

£159

GAME GEAR + GAME

£119

GAMEBOY - £69.95

CARRY CASE - £15.00

LIGHT BOY - £20.00

ILLUMINATOR - £15.00

MEGADRIVE

TOP 10	
1 MICKEY MOUSE	35.00
2 DICK TRACY	35.00
3 AEROBLASTER	35.00
4 TIGER HELI	35.00
5 SHADOW DANCER	35.00
6 RINGSIDE ANGEL	35.00
7 WONDERBOY III	35.00
8 STRIDER	40.00
9 JOHN MADDEN	40.00
10 SUPER MONACO	35.00

NEW GAMES	
MIDNIGHT RESISTANCE	35.00
SWORD OF SODAN	35.00
MUSHA ALESTE	35.00
KA KE GI	35.00
WRESTLE BALL	35.00
SONIC THE HEDGEHOG	35.00
GAIRIES	45.00
AMBITION OF CEASER	45.00
GYNOUNG	35.00
VOLFIED	35.00

USED GAMES		
TITLE	NEW	USED
RINGSIDE ANGELS	35.00	26.00
BATTLE SQUADRON	40.00	30.00
HELLFIRE	35.00	26.00
GHOSTBUSTERS	35.00	26.00
THUNDERFORCE III	40.00	26.00
GOLDEN AXE	35.00	26.00
BATMAN	40.00	30.00
SUPER HANG ON	35.00	23.00
GHOST 'N' GHOULS	45.00	29.00
POPULOUS	40.00	26.00
RAMBO III	30.00	22.00
FIRE SHARK	35.00	26.00
BUDOKAN	40.00	26.00
AFTERBURNER II	35.00	26.00
THUNDERBLADE	35.00	23.00
CYBERBALL	35.00	23.00

PC ENGINE
HANDHELD

£299

INC GAME

LARGE SELECTION OF NEW
AND USED PC GAMES

NINTENDO

TOP 10	
1 MEGA MAN II	39.95
2 SNAKE RATTLE ROLL	24.95
3 WORLD WRESTLING	34.95
4 BLACK MANTA	29.95
5 SOLAR JETMAN	29.95
6 SUPER OFF ROAD	24.95
7 BAYOU BILLY	34.95
8 PROBOTECTOR	29.95
9 GHOSTBUSTERS II	34.95
10 SUPER MARIO II	39.95

NEW GAMES	
STEALTH ATF	29.99
PINBOT	29.95
PAPERBOY	19.95
FAXANADU	29.95

SUPER FAMICOM
+ 2 GAMES

£299

GRADIUS
FINAL FIGHT
PILOT WINGS
ACTERISER
MARIO WORLD
F-ZERO
TOP GOLF
POPULOUS
BIG RUN

ALL TITLES £45.00

NEW USA
ATARI LYNX
+ UK PSU
ONLY

£89.00

GAME GEAR

COLUMNS	30.00
G-LOC	30.00
PENGO	30.00
SUPER MONACO	30.00
WONDERBOY	30.00
PSYCHIC WORLD	30.00

WHIZZ-KID GAMES,
UNIT 9, MID KENT
SHOPPING CENTRE,
ALLINGTON, MAIDSTONE
KENT, ME16 0XX

PLEASE ADD TO ALL ORDERS
P&P £1 PER GAME, £5 CONSOLES

FAST DELIVERY
PERSONAL CALLERS
WELCOME.

NAME
ADDR

TEL

C/CARD NO

EXP DATE

ALL CHEQUES MUST BE SUPPLIED WITH CHEQUE CARD NUMBER

GAME

MACHINE PRICE

CARRIAGE

CHEQUE
ACCESS/VISA

TOTAL

NEW

THE COMPLETE COLOUR SOLUTION

£179

Vidi ... No 1 in UK & Europe (Leading the way forward)



Get the most out of your Amiga by adding:

"The Complete Colour Solution"

The Worlds ultimate creative leisure product for your Amiga. Capture dynamic high resolution images into your Amiga in less than one second.

And Look No Filters

Images can now be grabbed from either colour video camera, home VCR or in fact any still video source. The traditional method of holding three colour filters in front of your video camera is certainly a thing of the past. Because Vidi splits the RGB colours electronically there are no focussing or movement problems experienced by some of our slower competitors. Lighting is also less of an issue as light is not being shut out by lens filters. Put all this together with an already proven Vidi-Amiga/VidiChrome combination and achieve what is probably the most consistant and accurate high quality 4096 colour images ever seen on the Amiga.

The colour solution is fully compatible with all Amiga's from a standard A500 to the ultimate A3000. No additional RAM is required to get up and running.

You will see from independant review comments that we are undoubtedly their first choice and that was before the complete solution was launched. If you have just purchased your Amiga and are not sure what to buy next, then just read the comments or send for full review and demo disk.



Actual unretouched digitised screenshot

Features ...

- Grab mono images from any video source
- Capture colour images from any still video source.
- Digitise up to 16 mono frames on a 1meg Amiga.
- Animate 16 shade images at different speeds.
- Create windows in both mono & colour.
- Cut & Paste areas from one frame to another.
- Hardware and software brightness & contrast control.
- Choice of capture resolutions standard & Dynamic interlace.
- Full Palette control.
- Add text or draw within art package.

Amiga Computing: The best Amiga digitiser has had the technicolour treatment. Vidi must be one of the most exciting peripherals you can buy for your Amiga.

Micro Mart: When I first saw Vidi "in the flesh" as it were, at the CES show last September it looked to be the answer to a frustrated Digi View owner's dreams - in fact to see pictures appearing on screen without the customary two minutes wait seemed almost too good to be true. I have consistently produced more good quality pictures in the short time I have had Vidi than I ever did with Digiview.

Zero: Now under normal circumstances cheap usually means poor quality but this is not the case with Rombo. Why? cos Vidi-Amiga is the best digitiser for under £500 and I've tried them all.

Amiga Format: Where quality is concerned, Vidi produces some of the best results I've seen on any digitiser at any price.

Amiga User International: The latest addition to the Rombokit is called Vidi-RGB and brings this already impressive package to the realms of totally amazing. CONCLUSION: Who will find Vidi-Amiga useful? The answer to this is almost anyone with a video recorder or camera and a passing interest in graphics.



Full colour demonstration disk available for only £1.95 to cover P&P.

6 Fairbairn Road, Livingston, EH54 6TS. Tel: 0506-414631 Fax: 0506-414634

ROMBO
Limited