

# gameinformer®

THE WORLD'S #1 VIDEO GAME MAGAZINE

gameinformer.com  
SAINTS ROW: THE THIRD



SAINTS ROW: THE THIRD

» WELCOME TO STEELPORT, A CITY FOR SINNERS AND SAINTS



# EVOLUTION BEGINS

MAY 17 2011





# BRINK™

BRINKTHEGAME.COM



**RP**  
CONTENT RATED BY  
ESRB  
May contain content  
inappropriate for children.  
Visit [www.esrb.org](http://www.esrb.org) for  
rating information.

 Games for Windows

 XBOX 360

 XBOX LIVE

 PS3







© 2011 ZeniMax Media Inc. Brink, Bethesda, Bethesda Softworks, ZeniMax and related logos are registered trademarks or trademarks of ZeniMax Media Inc. in the U.S. and/or other countries. Developed in association with Splish Damage Ltd. Splish Damage and the Splish Damage logo are registered trademarks or trademarks of Splish Damage Ltd. All Rights Reserved. Windows, the Windows Start button, Xbox, Xbox 360, Xbox LIVE, and the Xbox logos are trademarks of the Microsoft group of companies, and "Games for Windows" and the Windows Start button logo are used under license from Microsoft. "PlayStation" and the "PS" Family logo are registered trademarks and "PS3" and the PlayStation Network logo are trademarks of Sony Computer Entertainment Inc. All Rights Reserved.

# OWN THE ULTIMATE TRON



**On Disney Blu-ray Combo Pack April 5**

WALT DISNEY PICTURES PRESENTS JEFF BRIDGES "TRON: LEGACY" A SEAN BAILEY PRODUCTION GARRETT HEDLUND OLIVIA WILDE BRUCE BOXLEITNER AND MICHAEL SHEEN MUSIC BY JASON BENTLEY EDITOR DAFT PUNK DIRECTOR OF PHOTOGRAPHY MICHAEL WILKINSON  
EXECUTIVE PRODUCERS JAMES HAYGOOD, A.B.C. PRODUCED BY DARREN GILFORD DIRECTED BY CLAUDIO MIRANDA, A.S.C. EXECUTIVE PRODUCERS DONALD KUSHNER PRODUCED BY SEAN BAILEY JEFFREY SILVER STEVEN LISBERGER BASED UPON CHARACTERS CREATED BY STEVEN LISBERGER AND BONNIE McABIRD  
WRITTEN BY EDWARD KITZIS & ADAM HOROWITZ AND BRIAN KLUGMAN & LEE STERNTHAL DIRECTED BY EDWARD KITZIS & ADAM HOROWITZ EXECUTIVE PRODUCER JOSEPH KOSINSKI

**PG PARENTAL GUIDANCE SUGGESTED**  
SOME MATERIAL MAY NOT BE SUITABLE FOR CHILDREN  
For Sequences Of Sci-Fi Action Violence  
And Brief Mild Language



**Disney.com/TRON**

VIDEO GAMES  
AVAILABLE FROM  
DISNEY  
DIGITAL ENTERTAINMENT

SOUNDTRACK AVAILABLE ON  
WALT DISNEY  
MUSIC/SOUNDTRACK

© Disney



Distributed by Walt Disney Studios Home Entertainment, Burbank, California 91521.

# BLU-RAY™ EXPERIENCE



- Includes:
- **Blu-ray 3D™**
  - **Blu-ray™ 2D**
  - **DVD**
  - **Digital Copy**

*Blu-ray™  
Movies Also  
Play on PS3*



Also New  
on **Blu-ray™**

PG



ANDY McNAMARA  
EDITOR-IN-CHIEF  
andy@gameinformer.com

Read my column or  
comment on this letter at  
gameinformer.com/mag or  
follow @GL\_AndyMc

## Attending My Own Funeral

Every year, the Academy of Interactive Arts & Sciences hosts my favorite video game event of the year, the D.I.C.E. Summit. It is the ideal affair for many reasons, especially because it brings a cross-section of the video game industry into one place to hear and see what the people that drive the companies that drive the industry think.

This includes backward-looking panels, forward-looking speeches, and some sessions that don't say anything at all. You never know what you are going to get, but it is always an interesting look at all the known reaches of the video game universe, including mobile, social, and the core games that I consider the greatest expression of the medium. Not to say that I don't appreciate a good mobile or social game, they just aren't as near and dear to my heart as the next big-budget console or PC game.

As I realized at the conference, mobile and social titles fill a different void in my gaming life. As EA Mobile VP of worldwide studios Travis Boatman pointed out, mobile games aren't just people filling in spare moments in their daily lives, they are an entertainment destination of their own. This is true of all the avenues the industry is heading, and is a testament to the power of games.

Case in point: I don't just watch television shows anymore. The first lull in the program, I break out my phone to catch up with work, read something online, or fire up one of the many games I take with me everywhere. Usually before I know it I'm more invested in the game than the show I sat down to watch.

Games were the surprise hit for the iPhone. Games were the surprise hit for Facebook. I'm going to go ahead and say games in whatever form are going to define all the technology we use in the future as well. That future is self-evident when you look at how many elements of our lives are filled with achievement points and badges for accomplishing the most mundane things. Gamification is happening everywhere, from frequent flier miles to making restaurant reservations.

For all my good feelings about the power of games and its future control of the human race, I can't help but get the sense that many game executives and game developers are pulling away from the beloved core game, at least to some degree, in favor of these casual alternatives. The social and mobile game spaces are different in all the ways that game executives love. They are easy to develop, cheap in comparison, and even a simple game where you shoot pigs with a slingshot can garner major motion picture interest.

I don't think triple-A super releases are going away anytime soon, but remember there are a lot more moms spending their afternoon playing whatever "ville" game they love instead of watching Oprah than there are core gamers buying the next big thing. If you want the core games to keep coming, show the industry you care by throwing your support behind the elite blockbusters (and not just first-person shooters). I know I couldn't live without them. Trust me when I say some of the D.I.C.E. sessions made me feel like I was attending my own funeral.

0411 contents



» 48

### Saints Row: The Third

Saints Row 2 embraced zany antics to help the series stand out, and things are getting even crazier in Saints Row: The Third. Volition introduces a massive new city, unified gang threat, and even more insane stunts than ever before.

by Dan Ryckert

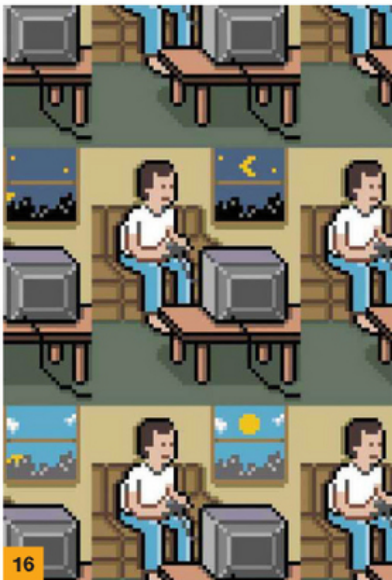

16



91

Killzone 3



58

Kingdoms of Amalur: Reckoning

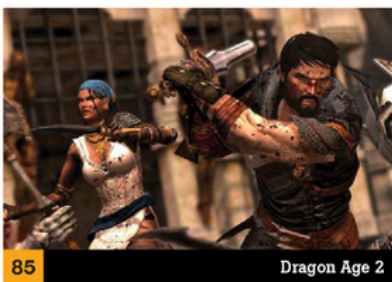

85

Dragon Age 2



35

Game Infarcer



68



40



66

Rage

## regulars

### » 8 Feedback

We sift through a glut of complaints and praise for our Top 50 Games of 2010 list, readers share their Skyrim desires, and we settle what games women are allowed to play.

### » 16 Connect

Learn about the ESA's smear campaign against a professor researching video games and violence, Sony Ericsson's Xperia Play phone, and the demise of Guitar Hero.

### » 64 Previews

We patrol the mysterious streets of L.A. Noire, survive a stint in the wastelands of Rage, and explore the new zombie apocalypse of Dead Island.

### » 82 Reviews

Does the follow-up to BioWare's stellar fantasy RPG Dragon Age: Origins fill the original's enchanted boots, or crumple like the victim of a Crushing Prison spell?

by Joe Juba

### » 100 Game Over

Get up close and personal with Gearbox's Randy Pitchford.



90



92



64

L.A. Noire



78



79



94



70

Infamous 2



80



76

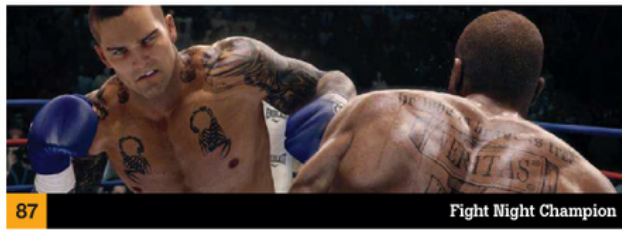

87

Fight Night Champion



88

De Blob 2

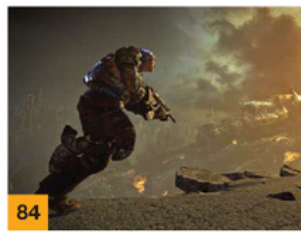

84



71

The Last Guardian

## games index

///	Anarchy Reigns .....	72
///	Beyond Good & Evil HD .....	96
///	Bionic Commando Rearmed 2 .....	96
///	Bulletstorm .....	84
///	De Blob 2 .....	88
///	Dead Island .....	77
///	Dissidia 012 Final Fantasy .....	95
///	Dragon Age 2 .....	85
///	Duke Nukem Forever .....	68
///	Dungeons .....	96
///	El Shaddai: Ascension of the Metatron .....	74
///	Fight Night Champion .....	87
///	Final Fantasy Versus XIII .....	79
///	Infamous 2 .....	70
///	Killzone 3 .....	91
///	Kingdoms of Amalur: Reckoning .....	58
///	Knights Contract .....	86
///	L.A. Noire .....	64
///	Last Guardian, The .....	71
///	Magicka .....	93
///	MLB 11: The Show .....	90
///	Monster Tale .....	95
///	Rage .....	66
///	Resistance 3 .....	78
///	Saints Row: The Third .....	48
///	SSX Deadly Descents .....	80
///	Super Street Fighter IV 3D Edition .....	94
///	Swarm .....	96
///	Tales from Space: About a Blob .....	96
///	Total War: Shogun 2 .....	92
///	Transformers: Dark of the Moon .....	76
///	Witcher 2: Assassins of Kings, The .....	73
///	Yar's Revenge .....	96
///	Yostar 2 .....	89



# EVO HAS AN ALTER EVO.

Introducing the new HTC EVO Shift 4G. It's 4G fast and powered by Android™, just like the EVO. But the Shift is smaller and has a slide-out keyboard to go along with its touchscreen. Now you can touch or type at the speed of 4G. Only from Sprint. The Now Network.™

**Sprint**  
The Now Network™



HTC EVO Shift™ 4G  
—Google

HTC EVO 4G  
—Google

[sprint.com/evo](http://sprint.com/evo)  
1-800-SPRINT-1 (1-800-777-4681)

While supplies last. Phone requires a two-year Agreement and activation on a select service plan with Premium Data add-on. **Other Terms:** Coverage is not available everywhere. The Nationwide Sprint Network reaches over 275 million people. The Sprint 4G Network reaches over 65 markets and counting, on select devices. The Sprint 3G Network reaches over 260 million people. See [sprint.com/4G](http://sprint.com/4G) for details. Not all services are available on 4G, and coverage may default to 3G/separate network where 4G is unavailable. Offers not available in all markets/retail locations or for all phones/networks. Pricing, offer terms, fees and features may vary for existing customers not eligible for upgrade. Other restrictions apply. See store or [sprint.com](http://sprint.com) for details. ©2011 Sprint. Sprint and the logo are trademarks of Sprint. The HTC logo and HTC EVO are trademarks of HTC Corporation. Android, Android Market, Google, the Google logo, Google Goggles and YouTube are trademarks of Google, Inc. Android is a trademark of Google, Inc. The Android robot is based on work created and shared by Google and used in accordance with the Creative Commons 3.0 License. Other marks are the property of their respective owners.



RadioShack



This month in Feedback we **discuss** what games women can and cannot play, **respond** to EA's misguided Dead Space 2 ad campaign, and **congratulate** some parents for doing their job.

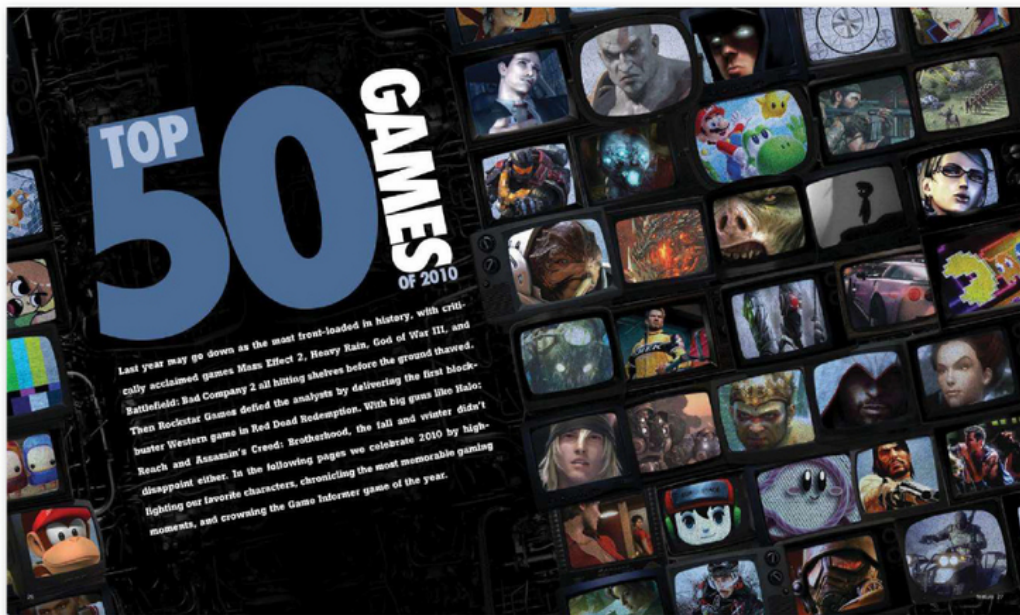

## Top 50 Cheers

I just want to say that I loved your Top 50 Games Of 2010 feature from issue 214. With so many Game of the Year awards trying to compare vastly different games, it's nice to be able to read an article that just says "All of these games are great!" Reading this list reminded me of how truly great 2010 was for gaming, and how many surprises there were (a Western can be good?). The best part is that 2011 is shaping up to be even better.

Quinn Levandoski  
via email

I was reading the Top 10 Editor Picks in your games of the year feature, and it seemed that Mass Effect 2 had just as much support as Red Dead did, which won the GoTY award. What pushed it over the edge?

Paul McNamara  
Glenside, PA

**The GI staff had plenty of love for both Mass Effect 2 and Red Dead Redemption. Ultimately, Mass Effect 2 is a refinement of the first game, and the second chapter in a still unfinished trilogy. Red Dead's wholly original, self-contained story, and deeply immersive game world gave Rockstar's epic Western the nod for Game of the Year.**

## Top 50 Jeers

When I saw your Top 50 Games article in last issue, I was NOT surprised to see you picked

Mass Effect 2 as the number one game [it wasn't; it received the Best Role-Playing award - Ed.]. You guys are the biggest fanboys I have ever seen! You never give other games a chance! I feel like ending my subscription to your outrageous magazine. You even put Shepard from Mass Effect 2 in your "30 Top Ten Characters" [30 X 10 = 300 characters? - Ed.]. You guys are idiots. You also give PS3 games a better rating than most Xbox 360 games. You guys are fanboys. You guys are idiots.

Sean Johnson  
via email

I've always found the majority of your articles to be well-written and researched, and have frequently scoffed at those who write in calling you out on supposed mistakes. However, it is impossible to overlook the astounding hubris your magazine displayed in your Top 50 Games list. Specifically when you said, "Final Fantasy XIII looks great and arguably features the best combat system of any RPG to date."

I found the combat to be the least engaging or interesting than even the dregs of the PSX era. When reading your article, I was almost sure that someone had used the "Find and Replace" tool in Word to exchange the words "Resonance of Fate" with "Final Fantasy XIII," as the cinematic, stylish, and tactical merits of that particular JRPG stand much higher than a pathetic attempt to again "revolutionize" the time-worn ATB system.

I won't dose with a melodramatic call for resignation like so many before me, but I have usually

found your magazine to be moderately abstract, and usually free from this type of hyperbole. I only wish you held your own journalism in the same regard that I do.

David Schimpff  
via email

**Thank you so much, David, for skipping the usual fanatical closing rant, and instead attacking our journalistic integrity. That's so much classier. Whether you take the direct (albeit misinformed) approach like Sean, or try to butter us up before launching into veiled insults, you're still mistaking your personal preference for some kind of incontrovertible truth. It's not. It's your own opinion, and we have our own opinions. We just also happen to have our own magazine.**

**Question  
Of The Month:  
Which are you  
more excited about:  
Nintendo's 3DS or  
Sony's NGP?**

**Contact Us**  
feedback@gameinformer.com

# yoostar<sup>®</sup> 2

## IN THE MOVIES



AND THE REVIEWS ARE IN...

*"...the next staple series for the party game scene."*

-DESTRUCTOID

*"I can definitely see this game being a lot of fun at a party."*

-IGN

*"Yoostar 2 is just plain fun"*

-POPULAR MECHANICS



Star in REAL Hollywood movies! Pick your role, stick with the script or improvise your own lines!

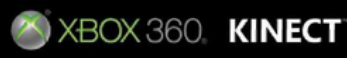

**INCLUDES 80 SCENES**  
WITH HUNDREDS MORE AVAILABLE

©2011 Yoostar Entertainment Group, Inc. All Rights Reserved. Yoostar<sup>®</sup> is a registered trademark of Yoostar Entertainment Group, Inc. Yoostar2<sup>™</sup> and all related titles and logos are trademarks of Yoostar Entertainment Group, Inc. All other trademarks and trade names are the properties of their respective owners. KINECT, Xbox, Xbox 360, Xbox LIVE, and the Xbox logos are trademarks of the Microsoft group of companies and are used under license from Microsoft. "PlayStation" and the "PS" Family logo are registered trademarks and "PS3" and the PlayStation Network logo are trademarks of Sony Computer Entertainment Inc.

## Short Answers to Readers' Burning Questions

- "If everyone on your staff voted, what would be your most anticipated game of 2011 out of these picks: Portal 2, Bulletstorm, or Diablo 3?"

### Portal 2.

"Is Iliomilo pronounced "eye-lo my-lo" or "eelo meelo"?"

"eelo meelo."

- "Do any of you have a secret identity?"

If we did, we certainly wouldn't admit it in a magazine.

## Best News Tip Of The Month:

"Don't feed your dog asparagus."

## Surprise Complaint Of The Month:

This month three readers wrote in to complain that Dante's Inferno was not included in the Top 50, which was three more than we were expecting.

# Reaching A Bigger Audience



I was very excited to see you guys finally broach the subject of race and sexuality in video games [Widening The Scope, issue 214]. I am an African-American woman and have grown tired of only being able to play most of my games as men or white women. You have no idea how excited I was when I first started Mass Effect and saw that not only could I make Commander Shepard a woman, but a black one at that. It angers me when most African-American characters are stereotyped as gang members or athletes. I believe that the game industry needs to realize that not everyone who buys their games are white males.

**Lyjanette Jordan**  
via email

I wish to congratulate Matthew Kato for his "Widening The Scope" article. I agree that there is a shortage of diversity in games, and when it is done right, it creates a unique experience for everyone and influences our lives tremendously. Many RPGs such as the Final Fantasy series (particularly 6, 7, and 10) do an amazing job of combining different ethnicities to deliver rich stories and characters. MMORPGs allow players to choose from a different mix of characters, and increases interactivity, cooperation, and immersion into those worlds by allowing players to create avatars that represent themselves physically and ethnically. While many of these games have great game mechanics and stories, I think they sell well because they also relate to gamers of many different backgrounds.

**Chad Collins**  
via email

gi spy



**(Left)** This is what happens when the Gi and Volition crews collide  
**(Right)** ...Actually, this is what happens. In Ben's defense, Dan had it coming

CANDID PHOTOS FROM THE VIDEO GAME INDUSTRY



GI SPY  
continued on page 12

# the first TEMPLAR



THE CONSPIRACY BEGINS APRIL 2011.



[WWW.THEFIRSTTEMPLAR-GAME.COM](http://WWW.THEFIRSTTEMPLAR-GAME.COM)

XBOX  
LIVE

HAEMIMONT  
GAMES

kalypso

Copyright © 2011 Kalypso Media Group. All rights reserved. All other logos, copyrights and trademarks are property of their respective owners. Windows, the Windows Start button, Xbox, Xbox 360, Xbox LIVE, and the Xbox logos are trademarks of the Microsoft group of companies, and "Games for Windows" and the Windows Start button logo are used under license from Microsoft.



## Your Customers Hate This

I was disappointed with the "Your Mom Hates This" advertising campaign EA chose for Dead Space 2. I have been trying to make the point to people that video games have really matured as a form of entertainment in the last decade or so. Whereas video games once used to be brainless entertainment without any real depth, they are now able to spark serious discussion and are capable of telling stirring narratives. However, "Your Mom Hates This" is exactly the type of sophomoric rationale for playing a game that I think the industry as a whole has been trying to move away from. The unfortunate thing is that Dead Space 2 is a genuinely great game with an excellent story. Why EA ever felt that the game's selling point should be something as childish as "Your Mom Hates This" is beyond me, but I think the industry as a whole is hurt because of it.

Joel Richard  
Jefferson Hills, PA



We couldn't agree more. Not only did the advertising campaign have the distinct feel that it was peddling an M-rated game to minors (unless you are an adult who still lives with your parents), it convinced us that the marketing team responsible for those commercials doesn't have any idea what makes the series so great. Hint: It's not because the game is "revolting" to mothers.

## The War Is Over

I just read the Editor's Picks in your Top 50 feature, and I was a little discouraged. I enjoy seeing other girls such as myself getting into the gaming world to kill the myth that video games are just for guys and that girls suck at them. But your two female editors, Megan and Annette, make every girl gamer look bad with top picks like Split/Second, Need for Speed, Dance Central, Donkey Kong, and Angry Birds. Come on girls:

What are we, five years old? I love games like God of War, Dragon Age, and World of Warcraft. In my first day of playing Black Ops I went 34 rounds in Zombie mode all by myself. I love girls who prove to guys that we are just as good at video games as they are. Putting out there that we play the same games that my eight-year-old nephew does makes us look pathetic. Come on ladies; play something a little more heavy.

Kathryn Kurse  
Roseville, MI

Gee, Kathryn, you seem to have conveniently overlooked the fact that Megan and Annette also put games like Mass Effect 2, Dead Rising 2, Red Dead Redemption, and BioShock 2 on their lists. Furthermore, even if they were only interested in playing Cooking Mama and Kinectimals, do you honestly think they lack the right to play the games they enjoy because they're women?

## Just Doing Their Job

I only own one M-rated game (which is Just Cause 2) because I am underage and my parents are afraid that they could "corrupt my mind." A long time ago, I preordered Call of Duty: Black Ops. It was going to be my first Call of Duty game that I would own. Eventually, my parents locked up videos of the game on YouTube and, well, they were pretty pissed. They said I couldn't purchase the game, but I tried to convince them otherwise. Alas, I failed, even though my classmates own this game. I understand that you are not my parents and they are just trying to do what is best for me, but other parents let young kids play this game. What do you think?

Michael Haft  
San Diego, CA

We think you should be grateful that you have responsible and informed parents. Thanks for doing your job, guys.

## Improvements For Skyrim

In issue 214 we asked readers what additions or improvements readers would like to see in the newest Elder Scrolls installment. While co-op/multiplayer was by and far the most common request, here are some other popular suggestions.

I would like to be able to create my own custom weapons and armor out of items I find throughout the world, and then infuse them with magic during the creation process.

James Sparks

One thing I hope Bethesda puts into Skyrim is cosmetic damage. After a long battle, I'd like some scars to remember it by.

Alex Greene



I don't want monsters to be leveled up to the player. There should be some places on the map that aren't meant for lower level players. It cheapens the game if the monsters/bad guys are always just as tough as the player.

Mitchell Sherkey

I would love to see some effort put into mounts or mounted combat. I would love to ride a dragon!

Dylan Carter

Please let this Elder Scrolls game have better animations. The stiff, marionette-like animations in previous titles made me lose interest in them. I just can't wrap my head around playing as a badass adventuring chick who looks like she's losing a deeply private battle with crippling early-onset arthritis.

Angela Williams

I'd like to see a random dungeon generator. It would be a candle on the icing of a really big-ass cake.

Eric Buck

## On Your Mind



- Top 50 Feedback **46%**
- Skyrim Love **34%**
- Racial Representation In Video Games **10%**
- Nathan Fillion > Mark Wahlberg **8%**
- Props For Ben's Obscure Xena Reference In Issue 214 **2%**

## GI SPY

continued from page 10

(Left) After witnessing the zombie action of Dead Island, PR guru Aubrey Norris and Deep Silver's Sebastian Reichert and Vincent Kummer pose with Jeff M in front of some appropriately messy artwork (Right) Ben is all smiles with DICE's Patrick Bach and EA's Pete Nguyen. If you just saw Battlefield 3, you'd be smiling, too





1

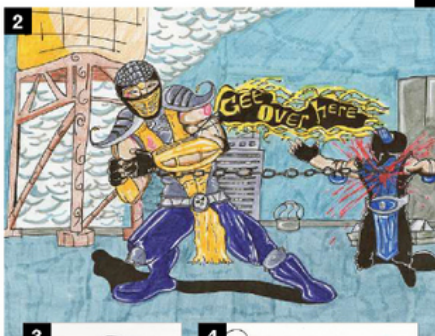

2



3



4

**WINNER 1 Miles Cass**

We love having these Tomiko figures in the office, but they have a nasty habit of getting elaborately separated from each other. **2 Tyler Bowen** Does Scorpion have a barbed wire bicep tattoo in this drawing? If that's the case, he's probably wearing an Affliction shirt under his ninja gear. **3 Edgar Ruiz** I think I must have missed the schematic for this suit in Dead Space 2. **4 Sean Boley** Listen, Mario... throwing Bowser into the damn sun didn't kill him in Galaxy. We're pretty sure that grabbing his tail again isn't gonna do much.



This month's **winner** will receive a copy of **WWE All-Stars** on the system of their choosing.

The greatest WWE Superstars and WWE Legends invite you to determine the greatest WWE Superstars of all-time in over-the-top, in-your-face, pick-up-and-play wrestling action.

**CORRECTION:**

Last issue in Gear, we stated that the Razer Switchblade's keyboard keys function like tiny LEDs. In actuality, they utilize LCD technology.

Enter the Game Informer Reader Art Contest. All you need to do is draw, paint, scratch, spit, or carve the best damn art you can think of and send it to us. Please include your name, phone number, and return address. If you're the monthly winner, we'll feature your work in G and you'll receive a video game prize from the Game Informer vault. All entries become the property of Game Informer and can't be returned.

Send to:  
Game Informer  
Reader Art Contest  
724 1st St. N.,  
4th Floor  
Mpls, MN 55401



**(Left)** Meagan hangs out backstage at Video Games Live with soloist Laura Intravia, host Tommy Tallarico, and production manager Brian DiDomenico. **(Right)** Here's Phil chilling in Japan with Ignition's Noriko Furukawa, Takeyasu Sawaki, and Shane Bettenhausen, after checking out El Shaddai for this month's preview.

# WE'RE NOT



Alcohol Reference  
Blood  
Mild Language  
Violence





IN AZEROTH ANYMORE

BUY NOW! [RIFTGAME.COM](http://RIFTGAME.COM)

TRION WORLDS IS NOT RELATED TO OR AFFILIATED WITH BLIZZARD ENTERTAINMENT OR AZEROTH.

©2011 Trion Worlds Inc. All rights reserved. The ratings icon is a registered trademark of the Entertainment Software Association. All other trademarks and trade names are the properties of their respective owners.

**TRION**  
WORLDS

**RIFT**

news

# Scientific

Is the ESA's criticism of video game studies

//////  
**NOTABLES**

- 20 afterwords: dead space 2
- 28 top ten fighting games we'd like to forget
- 30 impulse
- 32 telltale games
- 35 game infarct
- 40 interview: atlas' tim pinicny
- 42 gear
- 44 opinion: end user license agreements: can't read them, can't game without them



# Inquiries

a good practice? *by Matthew Kato with Jeff Cork*

The increased popularity of video games has put the medium in the spotlight, including frequent scrutiny by researchers and various groups trying to understand games and their effect on those who play them and society in general. Studies of all stripes are used to prove or disprove topics such as whether violent video games are harmful to kids, but there have yet to be any clear, answers to these questions because data like surveys and statistics can be inaccurate or disputed.

Recently, industry trade group the Entertainment Software Association (ESA) sent out a press release containing advance criticism of a study by Dr. Douglas Gentile (associate professor of developmental psychology at Iowa State University) and others about the negative effects of pathological video game usage, also known as video game addiction. The ESA warned that Gentile's study was "flawed" and called into question the doctor's motives and past work. While it's the ESA's job to protect video games and its constituency, what was unusual about the ESA's pre-emptive attack was that Gentile's report itself and its conclusions did not seem controversial.

Gentile's study of more than 3,000 school children in Singapore over a three-year period found that excessive gaming can have a negative effect on some kids, including the exacerbation of depression, anxiety, poor school work, and other issues. Gentile stopped short of announc-

ing a causal link between this kind of video game addiction and the aforementioned health issues, and while some kids he surveyed never developed a video game addiction, approximately nine percent of children surveyed (who averaged a gaming habit of 31 hours a week) could be classified as pathological gamers. Moreover, conditions such as depression and social phobias improved as these gamers stopped their pathological behavior.

Video game addiction is not a medically recognized condition, but Gentile used gambling addiction (which is recognized) as a comparison in developing his survey questions and an overall reference point because both start out as entertainment and later "stimulate emotional responses and dopamine release," according to the study. Similar to gambling, Gentile believes the basic cause of video game addiction is a lack of impulse control in the individual.

Despite the seeming clarity of his study's

findings, Gentile doesn't think the argument about video game addiction is over. "The purpose of this article," states the study, "is not to answer that debate, but to provide new data that may be useful." If Gentile's tone is relatively accommodating, why is the ESA so vehemently against him? The ESA declined to talk to us for this article, and its pre-emptive press release criticizing the study and Gentile himself provides few answers. In it the ESA says that pathological video gaming is not a medically recognized condition, and the tools the study uses to measure it have been criticized. However, the fact that it is not medically recognized is precisely what prompted the study in the first place, which required that Gentile and his colleagues use the methods they think are best suited to the task. In fact, the study is openly critical of itself, pointing out its own limitations and where more research is needed.

continued on page 18

“[The ESA] want people to believe that I am ‘anti-game!’ I don’t understand the general human tendency to prefer extremes to the truth that is usually somewhere in the middle.”

“We commend credible, independent, and verifiable research about computer and video games,” said Richard Taylor, the ESA’s senior vice president for communications and industry affairs in the press release. “However, this research is just more of the same questionable findings by the same author in his campaign against video games. There simply is no concrete evidence that computer and video games cause harm. In fact, a wide body of research has shown the many ways games are being used to improve our lives through education, health, and business applications.”

Many people believe that games can have a positive influence on our lives, but can you so easily take the good and ignore the bad? In the past, the ESA has praised studies that show games having a positive effect and criticized those like Gentile’s that don’t, but an effect is an effect whether it’s good or bad. Data and analysis from statistics and studies should always be scrutinized, but while highlighting only that which is favorable to video games may please the ESA’s constituency – and even form one of the cornerstones of the ESA’s legal arguments against its opponents – it’s a practice that brings into question the group’s legitimacy and obscures the honest scientific study of video games.

The ESA took such a selective approach in presenting evidence to the Supreme Court regarding its decision on the California law restricting the sale of violent video games to minors. The ESA cited two studies by Dr. Christopher Ferguson of Texas A&M, one of which (“The Hitman Study: Violent Video Game Exposure Effects on Aggressive Behavior,

Hostile Feelings and Depression”) found that violent video games may “reduce depression and hostile feelings in players through mood management.”

Ferguson’s study and the ESA’s trumpeting of it is all the same to Gentile, who observes, “People fail to recognize that if games can teach such good things like skills needed by surgeons, then they must also be able to teach other things, such as aggression. The learning mechanisms involved are the same.” Because of this, Gentile sides with the ESA when it says that video games can have a positive effect. Although the group’s press release states that he is anti-video games, in 2007 he released a study showing that video games helped laparoscopic surgeons with their skills and that they might be used as positive training tools.

Is Gentile an anti-video game villain or the champion of its better qualities? Or is he simply adding to the ever-growing conversation about the medium as it endures the scrutiny that inevitably comes with its evolution? The ESA’s stonewall defense may be an effective way to protect the immediate interests of the industry, but further obscuring the truth will only lead to more misunderstanding.



entertainment software association

Interview » **Dr. Douglas Gentile**



**Do you think video game addiction is different than sex addiction or other such specific addictions?**

That’s in fact what I’m trying to test – is it really like other addictions? My current summary of the existing research is that it looks like other addictions in many respects.

**Should video game addiction be officially medically recognized?**

Not yet. We still need more studies before I’d feel comfortable taking that step.

**Why do you think the ESA was so quick to discount your study before it was published?**

They’re just doing their job – protecting the interests of the video game companies.

**Do you have any comments about their criticism of your methodology?**

Although the ESA claims that this study is flawed, the statement provided no credible evidence of significant flaws. Furthermore, the article was subjected to peer-review by independent experts in a top medical journal, experts whose interest is in evaluating the quality of science. People might be interested to notice that the main criticism about my previous study

with American children (that an online survey was used) was solved in this study (where children were surveyed in classrooms), and the results were about the same in both studies. This type of convergence with different methods and different populations is a hallmark of good science, and when the results are replicated, it starts demonstrating that the effect is robust and believable.

**Do you think that it’s more likely that researchers will find a causal link between video games and bad behavior versus other forms of media?**

Probably not. Although there are theoretical reasons why video games might have a larger effect than other media (such as the interactive nature of them), the research is not demonstrating a larger effect. It seems to be about the same size as with traditional media, at least in the media-violence literature. Maybe other effects will be different.

**You’ve written about video games being a positive force as well as pointing out how video games can be harmful. Can you comment on the fact that some want to classify video games as either wholly bad or wholly good?**

Including the ESA, apparently, who want people to believe that I am “anti-game!” I don’t understand

the general human tendency to prefer extremes to the truth that is usually somewhere in the middle. Perhaps it’s best explained by what my father always said: “There are two types of people in the world. Those who divide the world into two types of things, and those who don’t.”

This tendency is particularly surprising when people fail to recognize that if games can teach such good things like skills needed by surgeons, then they must also be able to teach other things, such as aggression. The learning mechanisms involved are the same. This is why I’m so interested in all the different types of effects games and other media can have. My position is and always has been that games are powerful, and that they can have many effects. Some effects are beneficial, others can be harmful. The various effects depend upon many different features, upon the amount of time spent with the games, and possibly upon characteristics of the player. By being aware of both the potential benefits and potential problems, families can maximize the benefits while minimizing the harms.

# HOME IS WHERE THE **WAR** IS



# HOMEFRONT

IN STORES MARCH 15  
[DEFENDYOURHOMEFRONT.COM](http://DEFENDYOURHOMEFRONT.COM)

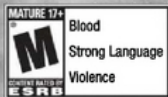

**KAOS**  
STUDIOS

**THQ**

© 2011 THQ Inc. Developed by Kaos Studios. THQ, Kaos Studios, Homefront and their respective logos are trademarks and/or registered trademarks of THQ Inc. All rights reserved. All other trademarks, copyrights and logos are property of their respective owners.



## Dead Space 2

**Dead Space burst onto the scene with a new and terrifying take on the survival horror genre.** In the dark, cold reaches of space it turns out that you can hear people – in this case, gamers – scream. The sequel continues the story of Isaac Clarke and his battle with dementia and reanimated human corpses. We asked Steve Papoutsis, Dead Space 2's executive director, to walk us through the challenges and triumphs of this latest installment. He sheds light on the story surrounding the Marker, difficulty balancing, and scripting the grizzliest death sequences this side of Mortal Kombat.

**Were you concerned about putting players in control of a character whose perception of reality is unreliable?**

We talked a lot about how we would handle the concept of dementia, what the effect would look like, how the audio treatment would support it, and if the player would understand it. So yes, it was something we thought a lot about and in the end we are very happy with how it turned out.

**Fans of the first Dead Space are familiar with your scare tactics. Was it difficult to come up with new ways to make players jump out of their seats?**

Keeping people guessing and setting up scare moments was definitely something we spent a lot of time discussing and working on. A lot of the tension and horror in the game comes from the sound design, the idea of hearing something and not seeing it. We also focus a lot on the dementia moments both in terms of the audio and the presentation around them. Horror is a tricky business.

**The Marker is at the center of Dead Space's mythology, but the role it plays is poorly explained in the game. Was this done to maintain a sense of mystery?**

The story of the Marker is something we tell across all of our extended media. For example, the novel *Martyr* focuses on the start of the Unatology religion and the discovery of the Marker. Trying to find a balance of keeping the mystery around the Marker alive is also good and helps draw speculation into the fiction.

**In the second half of the game, the difficulty level increases significantly. Was the plan to get players comfortable, and then tear them apart?**

The idea was, "Let's get folks acclimated with the controls, the upgrade process, and the core mechanics, then really test them as they push toward the end."

**The first Dead Space ramped up the difficulty by throwing different enemies and swarm combinations at the player. Dead**

**Space 2 continues this, but the hardest foes are more resilient versions of standard enemies. Why not create new foes?**

Dead Space 2 has 27 different enemy models that we feel offer a lot of variety, as each of them has a distinctive behavior. Also, through strategic dismemberment there is a strategy that players can use to be successful other than aiming for the headshot. We've even added lots of new enemies into the mix as we expand our universe. Keeping the core enemies like the Slasher, Leaper, Lurker, Infector, and others is important to our fiction. In terms of the new enemies the game has: The Stalker, Crawler, Nest, Cyst, Tripod, Pack, and Puker. That's a lot of new Necromorphs, and coupled with those returning enemies, you wind up with a ton of different and fun dismemberment opportunities.

**Dead Space 2 offers a wider variety of weapons, but rewards players for focusing on a smaller selection of arms. Do you think this discourages experimentation**

**with all of the weapons?**

The goal with the tools and weapons was to provide enough variety that players could find a loadout they really enjoyed. With our new game-plus feature, players can run back through the game and try out new weapons they may have passed up on their first playthrough. We also included our respect feature in case folks wanted to experiment with the different weapons and see what they felt like upgrading.

**All of the clocks in the game are set to 12:00. Is this significant to the story, or does the electricity keep going out?**

Yep, electricity failures across the Sprawl was the motivation behind the 12:00 thing. I mean, I could make up some wacky reason, but it was the power failures.

**Isaac's death sequences are always entertaining to watch. Were these fun to create? Did you have to dial any of them back because they were too gory?**

Isaac's unique deaths are always a ton of fun for the team. It's great to hear someone discover one when they are playing the game here at work. There are so many that not everyone has seen them all since folks are so focused on their particular part of the game. As far as us cutting anything due to gore, that has not happened. ♦

# de blob<sup>2</sup>

de VIDEO GAME

IN STORES  
NOW



*The revolution will be colorized!*



© 2011 THQ Inc. Distributed by Blue Tongue Entertainment Limited. US version developed by Halfbrick Studios and the UK version by Halfbrick Studios. All rights reserved. All other trademarks, logos and copyrights are the property of their respective owners. THQ, DS, Xbox 360, PS3, and the Wii logo are trademarks of the Microsoft Corporation and are used under license from Microsoft. The Xbox and PS3 Family logos are registered trademarks and the DS and the Nintendo DS logo are trademarks of Nintendo. THQ, DS, and Nintendo DS are trademarks of Nintendo. © 2011 THQ Inc.

bluetongue



Syfy Kids



news

# Booed Off the Stage

## Activision Cancels Guitar Hero Franchise

When *Guitar Hero World Tour* and *Rock Band 2* came out in 2008, it was almost inconceivable that the music peripheral sub-genre could crash and burn. At the time, these titles were sure-fire million sellers; their popularity spread to non-traditional gamers, and the public was eager to see how each franchise would push the genre with new music peripherals and gameplay. Less than three years later, the bottom has fallen out of music games. Sales figures have plummeted. Viacom sold off *Rock Band* developer Harmonix, and now Activision recently announced the indefinite suspension of the *Guitar Hero*, *DJ Hero*, and *Band Hero* franchises.

Activision revealed the move during its December quarter and calendar 2010 financial results, citing the "continued declines in the music genre." Activision laid off 500 employees working with the music franchises (including layoffs at other studios), scrapped a *Guitar Hero* title planned for release this year, and halted the creation of new DLC for the existing games. This is a far cry from 2008, when Activision CEO Bobby Kotick wondered aloud if the *Guitar Hero* series was strong enough to warrant a subscription model for its DLC.

So what killed the golden goose? The oversaturation of music games, the current economy, and licensing costs all contributed to the decline of the genre. According to NPD data, the series sales peaked when *Guitar Hero World Tour* sold 3.4 million copies and raked in more than a billion dollars for Activision. Comparatively, industry analysts Cowen and Company estimate that *Guitar Hero: Warriors of Rock* and *DJ Hero 2* failed to sell one million units combined in the U.S. in 2010.

Despite *Guitar Hero's* fall from greatness, Kotick told CNBC that Activision isn't opposed to bringing the series back in the future as long as it can be reinvented in some way. Given Activision's up and down track record with the franchise and genre, we hope that the company learns some lessons in the way it handles its valued brands. Otherwise, the encore won't be welcome.



### Rival Harmonix Responds To Death of Guitar Hero

In 2005 Harmonix teamed with publisher RedOctane to create the *Guitar Hero* franchise. After the massive success of *Guitar Hero II*, Activision purchased RedOctane and the franchise, but not Harmonix. Since then, the Boston studio started its own *Rock Band* series, was

picked up by Viacom, watched its *Rock Band* publisher MTV Games close its doors, and is now back where it started independent of any particular publisher.

Despite the history and rivalry between the *Guitar Hero* and *Rock Band* franchises, Harmonix community manager

and *Rock Band* network manager John Drake released a statement on *Guitar Hero's* demise:

"We were sad to hear yesterday that Activision was discontinuing development on *Guitar Hero*. Our thoughts are with those who are losing their jobs, and we

wish them the best of luck...

It's been a wild battle of the bands since 2007, but we respect and appreciate all of the hard work and innovation of our peers who have shared the music gaming space with us, and we look forward to rocking in the future."



# Pre-order now at GameStop®

power to the players™

AVAILABLE MAY 2011

# MX vs. ATV ALIVE™

For exclusive  
Supercross  
content go to  
[www.MXvsATV.com](http://www.MXvsATV.com)



© 2011 THQ Inc. THQ, MX vs. ATV Alive and their respective logos are trademarks and/or registered trademarks of THQ Inc. All rights reserved. All other trademarks, logos and copyrights are property of their respective owners. "PlayStation" and the "PS" Family logo are registered trademarks and "PS3" and the PlayStation Network logo are trademarks of Sony Computer Entertainment Inc. Kinect, Xbox 360, Xbox LIVE, and the Xbox logos are trademarks of the Microsoft group of companies and are used under license from Microsoft.

# the Good, the Bad, and the Ugly

news with a  
sarcastic  
spin

## Quotable

"There were elements that we found pretty cool, but had to set aside to remain on target. It's a big lesson we learned from the PS3. There's no point putting everything you want into a device and doing the math later. We always had the price and consumer in mind. We had to sell something that people could buy."  
— Shuhei Yoshida, Sony senior vice president of product development, on the price of the NGP handheld



Four years after the original, *The Darkness* returns in a sequel scheduled for release this fall on Xbox 360, PlayStation 3, and PC. The supernatura series puts players back in the shoes of newly minted mafia boss Jackie Estacado (once again voiced by Mr. Bungle's Mike Patton), with his four-limbed Darkness powers at his control. Original developer Starbreeze Studios isn't handling development duties for *The Darkness II*. Instead, Canada's Digital Extremes, which handled the multiplayer component of *BioShock 2*, gets the honor.



Good

Bethesda and *Fallout 3*: New Vegas developer Obsidian announced three more DLC content packs for the coming months. We don't have any specifics regarding the DLC, but Bethesda says that unlike the first DLC – *Dead Money* – these add-ons will be available simultaneously for the Xbox 360, PS3, and PC. Bethesda also recently applied for trademarks for the phrases "Honest Hearts," "Lonesome Road," and "Old World Blues."



Bad

*Batman: Arkham City* game director Sefton Hill confirmed that the game unfortunately doesn't feature any multiplayer or co-op. "So let me start by saying, once and for all, that *Batman: Arkham City* is a 'single-player only' experience," he told iGN. Hill elaborated that Rocksteady has a particular vision for the game, and that it wouldn't be possible to do the game it wants with multiplayer.

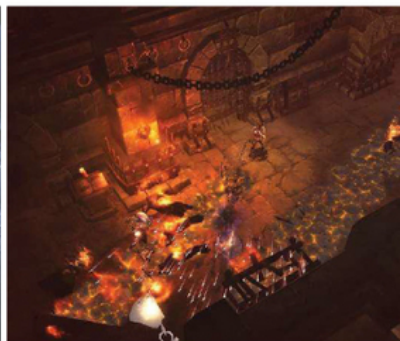

Activision Blizzard dashed the optimistic (or maybe naïve) hopes of gamers by not including *Diablo III* or any other Blizzard title in its 2011 fiscal guidance. The company says it's erring on the side of caution since there are no current release windows.

In other Blizzard news, the company is currently working on *Starcraft II: Heart of the Swarm*, but doesn't expect it until at least 2012.



If you're looking for April Fool's jokes, turn to page 35, because Ubisoft is not pulling our legs when it says that this summer's *Call of Juarez: The Cartel* mixes the series' western setting with present-day FBI officers in Los Angeles. The only possible good news about this game is that it seemingly must involve a hot tub time machine.



Ugly

It's getting a lot worse for THQ before it gets better, apparently. Although the company is moving in a new direction with its upcoming Montreal studio and games like *Homefront*, the restructuring is not without casualties. THQ canceled both free-to-play titles *Company of Heroes Online* and *WWE Smackdown vs. Raw Online*.

Speaking of *Homefront*, THQ is planning future games in the series, but the franchise may move from current developer Kaos Studios in New York to the new crew in Montreal.

Pre-Order now  
at **GameStop**  
power to the players™

THERE IS LIFE ON MARS.

# RED FACTION

ARMAGEDDON™

**RP**  
MAY CONTAIN CONTENT  
INAPPROPRIATE FOR CHILDREN.  
VISIT [www.esrb.org](http://www.esrb.org) FOR  
RATING INFORMATION.

**BREAKING 5.31.11**  
[REDACTION.COM](http://REDACTION.COM)

© 2011 THQ Inc. Developed by Volition, Inc. THQ, Volition, Inc., Red Faction: Armageddon and their respective logos are trademarks and/or registered trademarks of THQ Inc. All rights reserved. All other trademarks, logos, and copyrights are property of their respective owners. KINECT, Xbox, Xbox 360, Xbox LIVE, and the Xbox logos are trademarks of the Microsoft group of companies and are used under license from Microsoft. "PlayStation" and the "PS" Family logo are registered trademarks and "PS2" and the PlayStation Network logo are trademarks of Sony Computer Entertainment Inc.



PS3  
PlayStation 3



PlayStationNetwork



XBOX 360

XBOX LIVE



Syfy Games



# The PlayStation Phone

## Becomes A Reality

*Xperia Play comes with Crash Bandicoot*



Sony Ericsson officially unveiled its long-rumored smart phone/PlayStation-capable gaming device called Xperia Play at the Mobile World Congress 2011 in Barcelona, Spain.

The slider phone features a d-pad, customary PlayStation face buttons, two shoulder buttons, start/select buttons, as well as a multi-touch screen and two touch pads. It runs on Android's Gingerbread (version 2.3) platform, and Sony promises over five hours of battery life while playing games.

Although Sony just announced the NGP handheld as the successor to the PlayStation Portable, the NGP and Xperia Play tackle the gaming-on-the-go market from two different angles. Neither device fully overlaps with the other, and Sony believes each is uniquely suited to its particular audience, whether that's gamers who want a handheld gaming solution that approaches the home console experience or those looking for a phone capable of more robust gaming than is traditionally possible with just a touchscreen.

Sony Ericsson calls the Xperia Play "PlayStation Certified," and although there is no official roster of first-party PlayStation games announced for the unit, Crash Bandicoot is reportedly coming pre-installed on the device. The phone also comes with Asphalt Adrenaline 6, Bruce Lee, Star Battalion, The Sims 3, and Tetris. Fifty downloadable titles will be available at launch, and Engadget reports that Xperia Play compatible versions of LittleBigPlanet, God of War, and Call of Duty: Modern Warfare could be in the works as well. As for the games' price, we talked to a Sony Ericsson representative who told us that on average games should cost between \$4.99 and \$7.99, with developers determining the final price.

In the future, the Xperia Play's game library will be bolstered by PSN titles (although you have to re-buy them even if you already own them for your PS3), original PSone games, and through partnerships with over 20 publishers. The unit supports the Unity Engine, which is currently used by approximately 35,000 games, and third-party titles such as FIFA 10, Assassin's Creed, Guitar Hero, and Dead Space should be ported to the phone.

Sony trumpets its PlayStation Suite and PlayStation Certification programs as ways to encourage outside development, but it'll be interesting to see how mobile developers adjust to Xperia's different control configuration. Although we expect many studios to embrace the more gaming-friendly controls, we wonder if some companies will lazily port over games using only the device's touchscreen or touch pads. Moreover, Sony is touting that PSN titles will be available for the phone, but given that PSN games up to this point have been designed for the two analog sticks of the DualShock 3, it seems inconceivable that the Xperia Play will make use of the entire PSN catalog as it stands without control alterations.

Sony is convinced that releasing both the Xperia Play and the PlayStation NGP is a sound strategy, and it is trying to design both devices to cater to each audience. Sony hasn't released pricing details, but look for the phone to launch this spring on the Verizon network.

#### Xperia Play Specs:

- Size: 119 x 62 x 16 mm
- Weight: 175 grams
- Memory card support: microSD, up to 32 GB
- Memory card included: 8GB microSD
- Operating system: Google Android 2.3 (Gingerbread)
- Processor: 1-GHz Scorpion ARMv7
- Graphics: Qualcomm Adreno 205
- Screen: 4-inch, 854 x 480 multi-touch LCD
- Camera: 5.1 megapixel, auto focus, LED flash, video recording & more



## TOP TEN FIGHTING GAMES WE'D LIKE TO FORGET

by Dan Ryckert

### Star Wars: Masters Of Teras Kasi

Battling one-on-one with lightsabers seems like a concept that would be hard to screw up, but LucasArts manage to with this PSone brawler. Lightsabers are devastating in the Star Wars films, but Masters of Teras Kasi treated them like they were Nerf bats. When a Tusken Raider named Hoar can take 20 saber strikes to the skull, you know a game is going to earn the rage of Star Wars fans.



### Shaq Fu

So Shaquille O'Neal is wandering around Tokyo on the way to a big charity basketball game, right? He stumbles into a kung-fu dojo for some reason, then falls into a portal that sends him into another dimension. There, he has to rescue a kid from an evil mummy by mastering the art of Shaq Fu. Actually...maybe I don't want to forget this game. This all sounds pretty awesome now that I think about it.



### Kabuki Warriors

Back in 2001, we handed out a 0.5 score to this early Xbox offering. If that didn't paint a bright enough "don't buy this" picture for you, Andy McNamara wrote about how he won a match by literally mashing the controller against his ass (Quote: "I wish I was joking, but the score is seriously Kabuki Warriors zero, my ass one"). To be fair, that's how he tries to beat every game he plays. Mass Effect took him over 3,000 hours.



### Clay Fighter

Claymation and fighting games were hot around 1993, and this awful Interplay title attempted to capitalize on those trends. It tried hard to be humorous, but characters like an evil snowman, an Elvis impersonator named Blue Suede Goo, and a blob of clay weren't wringing many laughs from its players. Its humor never really hit the mark, but it was the terrible gameplay that cements its place on this list.



### Way of the Warrior

As great as Naughty Dog is today, they weren't always cranking out games of such caliber as Uncharted or Jak & Daxter. In the company's earlier years, it released this awful Mortal Kombat clone for the ill-fated 3DO. Characters featured awful controls and were crudely animated, with much of the capture work being done in front of a yellow sheet at developer Jason Rubin's apartment. The only way you could have enjoyed Way of the Warrior is if you're the biggest White Zombie fan in the world, as their music played throughout the entire game.



### Street Fighter: The Movie

Wrap your head around this one — this is a crappy fighting game based on a crappy movie that's based on an awesome fighting game. If they made a movie about this game, it would eventually turn into one of those funhouse mirrors where you see infinite reflections of yourself. This game extracted the classic gameplay of Street Fighter and injected a healthy digitized dose of Jean-Claude Van Damme.



### Warpath: Jurassic Park

I love fighting games, and I love Jurassic Park, but sometimes two good things just don't complement each other. Seeing a T-Rex battle a raptor to the death should be amazing, but Warpath does it so poorly that it makes Primal Rage look like Soul Calibur. If you were low on health, you could recover a bit by eating humans that wandered across the level. I'd love to watch these fights go down in real life, but I'd want to be half a mile away and outfitted in an old-timey metal diver's suit. The dudes in this game sprint right towards the PO'd dinosaurs like they're trying to break up a bar fight.

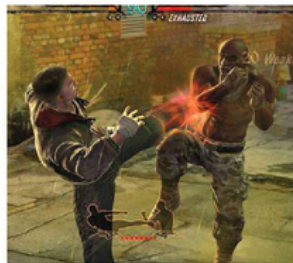

### Fighters Uncaged

Kinect launched with a variety of family-friendly titles like Kinectimals, Kinect Adventures, and Kinect Joy Ride, none of which had anything to offer for fighting fans. Neither did Fighters Uncaged. This abomination tried hard to be a gritty fighter that made you feel like a back-alley badass, but ended up with you flailing like you just walked into a bunch of cobwebs.



### Fight Club

Five years after David Fincher's film came out, Vivendi Universal got the bright idea that a popular movie about dudes punching each other might make for a good fighting game. Thing is, it didn't. Beating story mode unlocked the balding, talentless man-child Fred Durst, and beating the game with every character unlocked Abe Lincoln. I don't care if it's a reference to the movie, I don't need to see a former President getting knocked out by Meat Loaf. Despite all its problems, it does include one of the greatest features in video game history — the ability to beat the holy hell out of Jared Leto.

### Ballz 3D

I'm not sure this game could scream "1994" any louder if it tried. You've got a "Z" replacing an "S," "edgy" sexual innuendo, and an awful attempt to present 3D graphics on a 16-bit system. Characters were supposed to include a caveman, a farting monkey, and a ballerina that spanked you, but everything ended up looking like an AutoCAD rendering of a Dippin' Dots factory explosion.

# SAINTS ROW™

— THE THIRD —



*Strap it on. Holiday 2011*



© 2011 THQ Inc. Developed by Volition, Inc. THQ, Saints Row: The Third, Volition, Inc. and their respective logos are trademarks and/or registered trademarks of THQ Inc. All Rights Reserved. All other trademarks, logos and copyrights are property of their respective owners. KINECT, Xbox, Xbox 360, Xbox LIVE, and the Xbox logos are trademarks of the Microsoft group of companies and are used under license from Microsoft. "PlayStation" and the "PS" Family logo are registered trademarks and "PS3" and the PlayStation Network logo are trademarks of Sony Computer Entertainment Inc.



Hybrid  
Xbox Live Arcade

## We examine **Hybrid** and **From Dust**, two of the most ambitious downloadable games of 2011

by Matt Miller

When Scribblenauts developer 5th Cell announced that its next game would be a sci-fi shooter, we were surprised and excited about the innovative team tackling the genre. This month, the team shared a wealth of new details on **Hybrid**, which is planned to release on Xbox Live Arcade later this year.

**Hybrid** is set in the year 2031, some time after a massive asteroid decimates most life on Earth. A bacterium carried on the asteroid infects half of the surviving population, transforming them into a genetically altered race called the Variant. Opposing them are the humans immune to the bacterium, who call themselves the Paladin. These two opposing forces don't exactly get along.

"Hybrid is a competitive multiplayer-only, third person, cover-based shooter set in a persistent online world war divided between the two factions," explains creative director Jeremiah

Slaczka. Each battle in the game is part of a persistent war that is constantly being waged. The two battling groups fight to control territories and eventually entire countries in an effort to dominate the shattered Earth. Slaczka didn't discuss game modes, but the 3v3 matches take place on small maps and never last longer than 10 minutes. "The entire game is built to be laser-focused on allowing the player to have a fun, fast, enjoyable session," Slaczka declares.

One of the most surprising concepts is how 5th Cell is handling navigation; the team has crafted a mechanic they call combat focused movement. "In real war scenarios, soldiers don't run and gun around cover; they stay in cover, only moving out for a better tactical position like rushing, flanking or retreating. We wanted to capture this experience in **Hybrid**," Slaczka explains. "Players select the cover they want to move to using the L-Stick, press A, and their character will automatically move to that cover. During movement, players

can aim and shoot in a 360 degree motion while still confidently moving toward their destination. To retreat, players just need to hit B and their hero will automatically retrace his steps to the previous cover, which can be queued up to three times. The system is very intuitive, and players can change covers mid-run by selecting a new cover group if they want." The unique approach puts the player's focus solely on aiming and firing as they move around the battlefield.

Characters have access to jump jets that let them take cover on the wall, or even upside down on the ceiling, so when moving through the environment situational awareness is tantamount.

While the gameplay is easy to pick up, it still has depth. Players can unlock new weapons and abilities as they play. Slaczka described some of the ways these unlockables combine, like adopting an invulnerable meta-shield and then equipping a combat shotgun, enabling a wild charge into enemy cover to drop them all at close range. A "squads on demand" function lets players call in allied AI units to their current cover point — three different unit types each serve a unique role on the field, from stealthy support troops to armored machine gunners. You build up the ability to summon these helpers with each enemy kill. Other special abilities include poisoning enemy units or siphoning health to your side.

"It works great combined with the SWARM Rifle, which shoots a huge ball of energy, engulfing the cover, wounding anyone in its radius, and then giving the player their health back," Slaczka says.

**Hybrid** sounds like a refreshing take on a genre that is more than ready for some new blood. I'm hoping to get my hands on the game soon and confirm my suspicions. Between the developer's pedigree and the innovative design ideas at play, **Hybrid** has enormous potential.

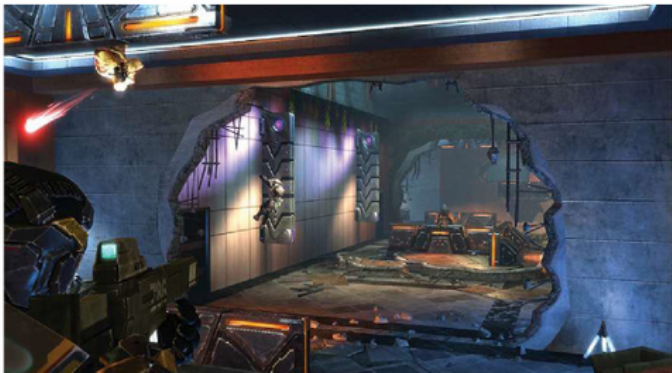



From Dust  
PlayStation Network, Xbox Live Arcade, PC

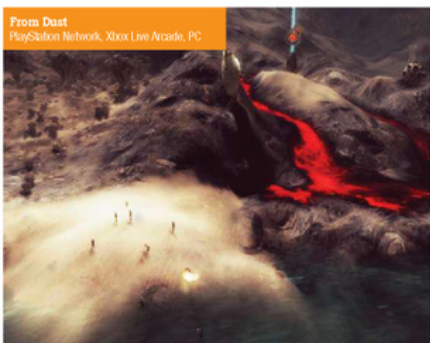

In 1991 designer Eric Chahi introduced gamers to *Out of This World*, a stunning action/adventure title that wowed players with its cinematic approach to platforming. Twenty years later, Chahi is leading the team to craft a gorgeous new Ubisoft game called **From Dust**.

"If we had to sum up *Dust* in two words, then the term 'god game' would be pretty appropriate, to the extent that the player has almost god-like abilities and has great leeway to alter the terrain," Chahi says. "But the term 'god game' does not tell the whole story."

*From Dust* gives players control of a spirit that watches over a tribe of humans as they seek to uncover their forgotten powers and history. Acting as a floating ball called "the Breath," players manipulate the environment to move the story forward.

"You can pick up matter – water, earth, lava, vegetation – shift it, and drop it. All the fun of the sandbox!" Chahi describes. "As all environments are based on a physics simulation of fluids and solid terrain, you can really see everything reacting and adapting to the player's activity. You

can watch rivers being created and divert them. You can control volcanoes, create dams, and irrigate zones to cultivate plants, all in the aim of helping a tribe survive in the face of nature."

Time operates differently in the game world; erosion occurs at an accelerated rate, even as water seems to flow normally. Lava turns to hard rock as it flows into the sea. Trees and other vegetation grow in a matter of seconds. "If the player picks up earth and drops it in a river, the river will change its course, and a new river will be created by erosion," Chahi explains. "Maybe it will flood a valley containing a village, or maybe it will extinguish a fire. The player will have to evaluate the impact and repercussions of his or her own actions, as a domino effect comes into play."

Along the way, players can steer the development of the humans, but they have little direct control over the tribe's actions. Create a stable zone of terrain, and human culture will begin to flourish by planting crops and building statues. As the game continues, the boss encounters are the natural disasters that threaten to overwhelm

humanity. In response, the tribe can develop special abilities that let them hold back the worst ravages of nature.

"Humans in *From Dust* are capable of altering and controlling elements by using a powerful drum-based music," Chahi says. "Music has an intricate connection to the game. For example, humans have the power to repel water to protect themselves from flooding or tsunamis. We actually see humans playing music and the water drawing back in perfect sync with each beat of the drum. Visually, it is captivating."

*From Dust* smartly interweaves layers of story, adventure, and puzzle elements. I love the terrain manipulation concept, and how the game is rooted in the metaphorical presentation of cultural and ecological change.

"The *From Dust* world is alive and independent; the landscape is not just a décor, it is an actor, and that changes everything," Chahi tells me. "The world suddenly acquires depth. There is a real climax; the tension is palpable. You can really feel the forces of nature at work in the game." Look for *From Dust* this summer. ♦

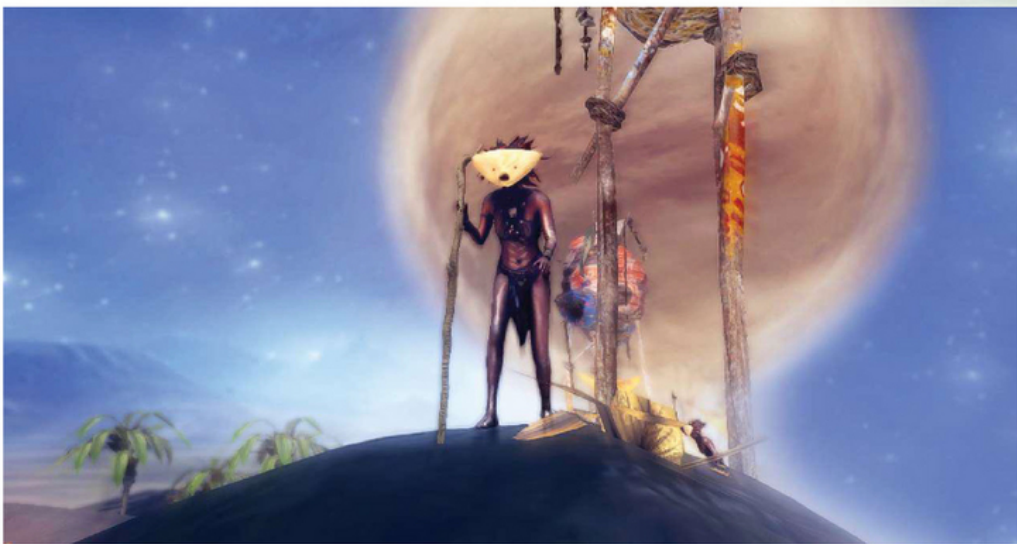

Looking for more details on the downloadable and independent game scene? Check out [gameinforma.com/impulse](http://gameinforma.com/impulse) for daily updates on the best titles coming to PlayStation Network, Xbox Live Arcade, WiiWare, and PC. For our review scores on recent downloadable titles, flip to page 98 of this issue to learn more about *Beyond Good & Evil HD*, *Bionic Commando Rearmed 2*, *Swarm*, *Tales from Space: About a Blob*, and *Yar's Revenge*.



A quick look at some of the games Telltale will deliver in 2011



### Hector: Badge of Carnage

PC | Mac | iOS

Telltale and Irish studio Straand-looper are teaming up to bring the gritty comic detective caper Hector: Badge of Carnage to a wider audience in 2011. Under the deal, the companies will release the original iPhone episode to more platforms and deliver two new episodes later this summer.



### Fables

TBD

"Bill Willingham's *Fables* brings everything we look for in a property to bring to episodic – strong, iconic characters, deep, nuanced story arcs, and rich, fully realized worlds," Connors says. "This is a series that will work extremely well for the cinematic style of adventures that Telltale delivers."



### The Walking Dead

PC | Mac | Console | Handheld | Mobile | Social Gaming

Telltale is waiting until San Diego Comic-Con to divulge more details on the *Walking Dead* game, but they are saying that the game delivers an experience that's faithful to the comics. "If you don't start five minutes of the game and feel like you're in the *Walking Dead* universe, then we probably did something wrong," says writer and lead designer Sean Vanaman.



### Puzzle Agent 2

PC | Mac | iOS | PS3

The first *Puzzle Agent*, described as "Professor Layton meets *Fargo*," was the inaugural title launched under Telltale's pilot program. The program lets Telltale release a concept to market in the form of a single episode to see how it's received before committing to a season-length series. It was successful enough to get picked up for a sequel, due out this summer.



### King's Quest

TBD

Details on Telltale's return to Davenport are scarce, but Connors revealed that *Tales of Monkey Island* may serve as an inspiration for the series reboot. "Let's look at the whole thing, let's figure out where they left the story, let's find the most interesting places to go to and embellish upon, and let's go there," he says.

# "THE BEST NEW SHOW ON TV"

—ENTERTAINMENT WEEKLY



## The Complete First Season on Blu-Ray™ and DVD.

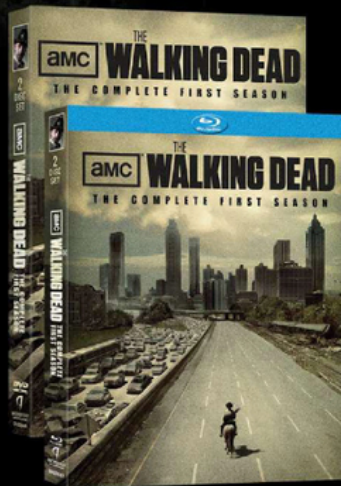

Available At **NETFLIX**

And Other Retailers Near You

# March 8

[www.amctv.com/originals/The-Walking-Dead](http://www.amctv.com/originals/The-Walking-Dead)



Distributed By Anchor Bay Entertainment, LLC  
Package Design © 2010 Starz Media, LLC  
Program Content © 2010 AMC Film Holdings LLC  
All Rights Reserved.



# PickUp @Store



**PickUp@Store** is a new program allowing you to find products online and pick them up at your local **GameStop**.

## 1 Pick your product

Click your item's "PickUp@Store" button.



PickUp @Store



## 2 Pick your store

Choose a store near you that has the item in stock. Then click "PickUp@Store."

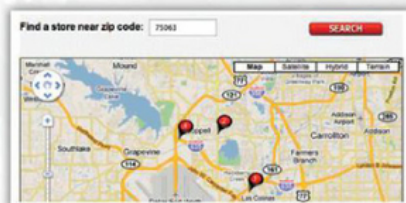

PickUp @Store



## 3 We'll hold your item

Then we'll send you a Ready for PickUp e-mail with pick up instructions.



## 4 PickUp your goods

With confirmation email in hand, let your friendly GameStop associate know you have an item being held for you.



- ➔ **SAVE TIME** - No waiting for shipping. Play your game now.
- ➔ **SAVE MONEY** - No shipping or delivery fees.
- ➔ **SAVE GAS** - No more driving all over looking for your game.
- ➔ **TRY IT** - Less time waiting is more time playing. Truth.

PickUp@Store available at  
[www.gamestop.com](http://www.gamestop.com)

**GameStop**  
power to the players™



JAPANESE DEVELOPER

WON'T SHUT UP ABOUT HOW MUCH JAPANESE DEVELOPMENT SUCKS PG. 64

ACTIVISION

JUST SHUTS DOWN EVERYTHING PG. 76

# gameinfarcer®

THE WORLD'S #1 PRETEND MAGAZINE

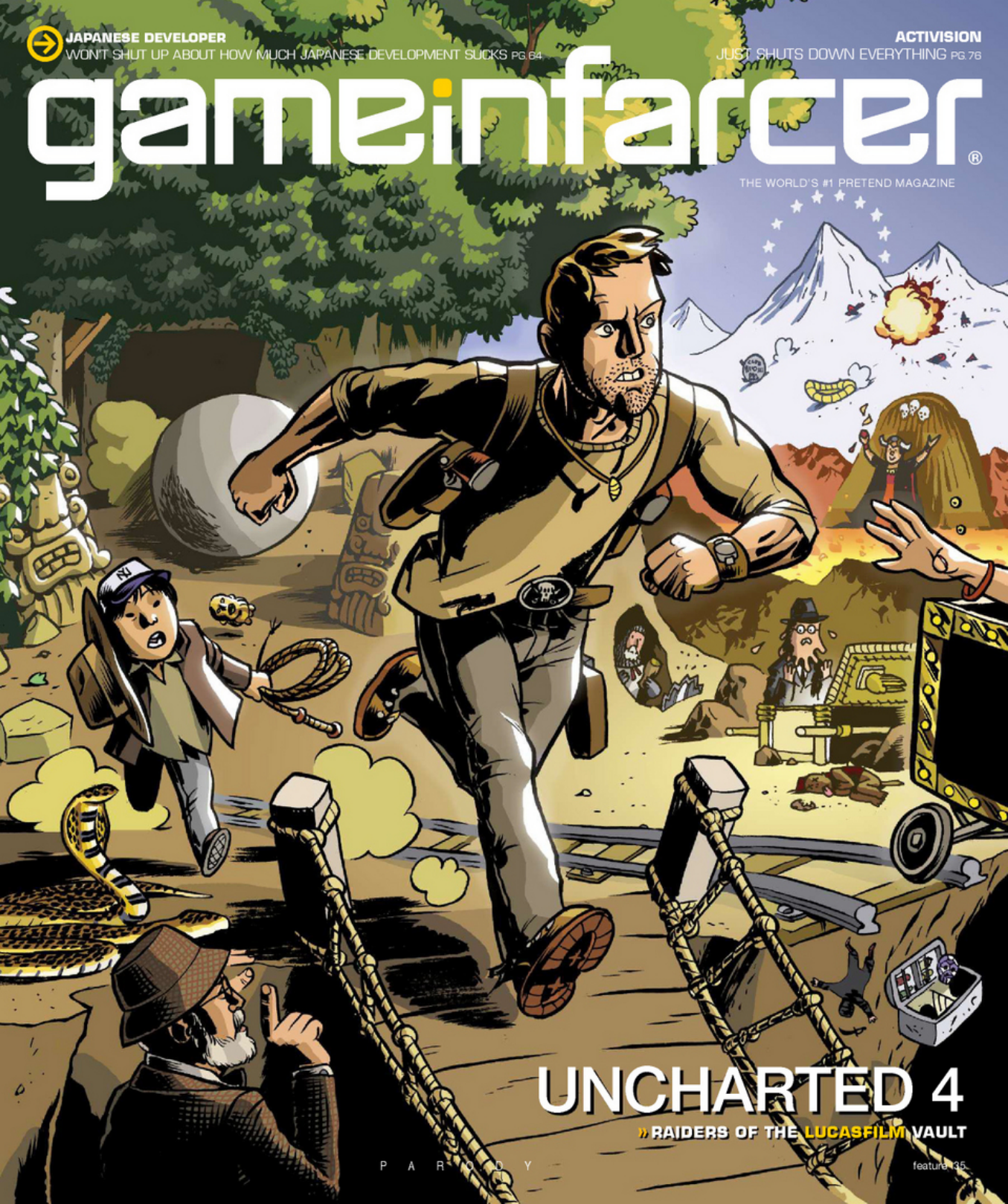

## UNCHARTED 4

» RAIDERS OF THE LUCASFILM VAULT

P A R O D Y

feature 36

# I Will Educate You



DARTH CLARK  
EDITOR-IN-CHIEF

Read my column online or follow @GL\_Darth

Some people will tell you that defining the term “gamer” is difficult and pointless. Those people are morons. If we don’t decide exactly what it means to be a gamer, then how can we feel superior to those who fail to meet our criteria? Don’t worry: I have all of the answers.

If you like social games, you are not a gamer. Seriously, if you’ve ever played a single game on Facebook or your iPhone, don’t even talk to me, because you are barely even a person. Same thing goes for the people that only play one game non-stop. News flash: Making a bunch of muscle dudes hug each other for a few seasons in Madden does not make you a gamer.

If you like mainstream series like Halo, Assassin’s Creed, or Final Fantasy, you definitely cannot call yourself a gamer. “Oh, I love Red Dead Redemption, just like the millions of other people who bought it!” Way to be original, sheep. Oh, and don’t think reaching prestige five in Call of Duty is a free ticket...it’s just another way of announcing that you’re a fake gamer who only follows the crowd.

Real gamers don’t like the popular crap everyone else does. If we did, we would have no way to showcase our discerning taste. Underground indie PC titles, bizarre imports from those tiny European countries, and poorly localized RPGs with archaic mechanics are the gourmet dishes that we gaming connoisseurs dine upon. By playing games no one else has ever heard of, we ensure that our opinions can never be challenged, sealing victory in any gaming argument.

Maybe you have your own definition of what it means to be a gamer. That’s cute, but which one of us is the editor of a massive video game publication? You’re free to disagree with me, but here’s a little secret: That’s another sign that you aren’t a hardcore gamer.

Cheers,

*Darth Clark*

Darth Clark

gamer

## Final Fantasy XIV



**Real Name:**  
[Withheld To  
Protect Dignity]

Handle  
Chocobro

### Accomplishments:

Chocobro is the longest-standing (and only remaining) Final Fantasy XIV subscriber in the world, having maintained an active account for two months. “Honestly, I haven’t even played for, like, six or seven weeks,” he says. “I just can’t figure out how to cancel my account.”

### Best Class:

“I think my guy was a mage or a fighter.”

### Favorite Feature:

“All that stuff with Deathwing and Cataclysm was pretty sweet. Wait...nevermind.”

gear



1

2

### 1 Game Bed

The makers of GameGulp energy drinks and GameYUMM XL snacks are at it again with their latest gamer-exclusive product, the Game Bed. “Sometimes even the most hardcore gamers need to snipe some Zs after long nights of blasting bad guys and tearing through galaxies in spaceships,” says Ron Clarkson, president of GameDoodz LLC. “That’s where the Game Bed comes in, providing the hardcore slumber gamers crave. Sleep is gonna get pwned!” Game Bed is a compatible with pillows and sheets, and is only available as a full-sized single bed. After all, gamers this extreme never need to worry about a bed big enough for two.

### 2 3DS Perfect View

The 3DS fixes consumers’ main complaint with 3D technology: weird glasses. Unfortunately, to experience the full 3D effect, players have to view the screen at precise angles or risk instant cataracts. Instead of using the level and plumb bob that come packaged with the 3DS to calibrate the proper viewing position, why not buy the Perfect View? The medical-grade polycarbonate device props the 3DS at the optimal angle while firmly preventing any stray movement of your head and neck. It may not be the most comfortable way to play, but at least you won’t be wearing those ridiculous glasses.



news

## Sony Reveals Incomprehensible NGP Pricing

After the recent debut of the next generation portable PlayStation system, Sony has finally peeled back the pricing details on the NGP. See if you can figure it out, because we're drawing a blank here.

- Wi-fi model (\$299)
- Wi-fi and 3G-enabled (\$399)
- Wi-fi, 3G, and Move compatible (\$499)
- Cell phone edition. Default ringtone is an autotuned take on Kaz Hirai's classic "Rillidge Racer" meme (\$599)
- Screenless, non-portable option that plugs into a TV and plays the entire PS3 collection (\$699)
- Smaller screen model with only one analog stick and accepts PSP UMDs. Also includes a puppy, for some reason. (\$799)
- Wi-fi and 3G-enabled. Features nuclear uranium core for infinite battery life. The only model to include backwards compatibility (\$99,999)



instruments of war

## Activision Unveils New Gun Peripheral

Following Activision's recent cancellation of the Guitar Hero franchise, the manufacturer is exploring new ways to bundle cutting-edge peripherals with their most exciting brands. The latest endeavor aims to add depth and realism to the hyper-successful Call of Duty franchise by putting a replica of authentic U.S. military future-tech in the hands of gamers. The Stratling Gun peripheral features a unique trigger mechanism which allows players to pick off single targets with a flick of the thumb, or shred waves of enemies by rapidly moving the trigger up and down. Players can select between different color-coded ammo types by depressing buttons near the gun's barrel, such as green gas grenades for beginners, and orange napalm strikes for experts. The Stratling Gun retails for \$129.99, but Activision is offering a discount to anyone who trades in a used Guitar Hero controller at purchase, no questions asked.

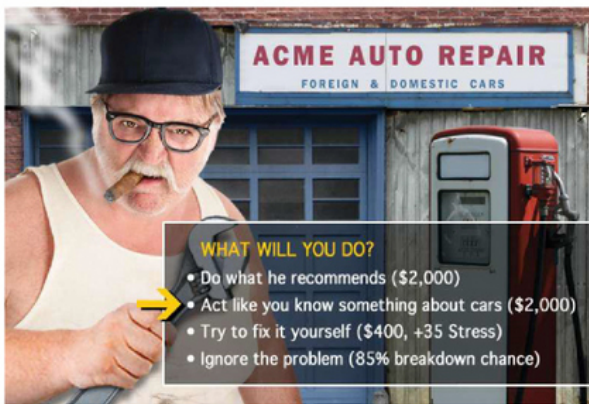

maintenance

## Gran Turismo 5 Gets Even More Realistic

Polyphony Digital and Sony have heard user complaints regarding unimpressive car damage in Gran Turismo 5, and they're set to address those issues and more in a new title update. "Damage is an integral part of racing, and we're taking it to the next level," says studio president Kazunori Yamauchi. Games have featured details like tire wear, crumpled hoods, and detached bumpers, but they haven't captured the real experience of car ownership. This update gives every player a new garage that just holds two cars – then the fun begins. "Car customization is so realistic that only an actual mechanic could possibly understand what's happening," says Yamauchi. Gamers who aren't familiar with how cars work can still interact with their vehicles by inspecting the garage floor for mysterious stains and leaks, trying to suss out why the "check engine" light won't stop blinking, and popping the hood to stare impotently at that bewildering mess of an engine. Once their car stops running or gets in a wreck (hope you bought in-game insurance!), players must turn to the people on their friends list, asking for a virtual ride to the game's microtransaction-supported repair shop. "We're intent on bringing players the most realistic experience on the market today," Yamauchi insists. "This is what driving is all about."

## DataFile

### Microsoft On Kinect: We're So Busted

If you're one of the eight million Kinect owners looking forward to the second wave of releases, Microsoft has some bad news for you: There aren't any. "We didn't anticipate that people would want to continue playing Kinect, so we never planned any more games," said Microsoft's Kudo Tsunoda. "We're mystified by the device's success. Frankly, the whole project was just an elaborate tax dodge."

### EA Buckles Under Pressure

Retreating from its "every game needs a good guy and a bad guy" stance, EA has caved in to protests and removed necromorphs from the Dead Space series. NASA scientists threatened to boycott the game at launchpads and the international space station due to its frightening and unflattering portrayal of space travel. The only scares Isaac needs to worry about now is running out of astronaut ice cream and jamming up the one working shuttle toilet.

### Killzone 4

Killzone 3 supported 3D along with PlayStation Move, but the latest entry in the Killzone franchise will incorporate even more gimmicks – a goal previously thought impossible. "This time we just said, 'F--- it,'" reveals a Sony rep. "We use the Rock Band guitar, Tony Hawk board, and uDraw Tablet – basically anything that only six percent of players will even try before immediately returning to the normal controls."

## LittleBigPlanet 3

Taking user creation tools to terrifying heights



- » **Platform**  
PlayStation 3
- » **Style**  
1-Player  
Development Kit
- » **Publisher**  
Sony Computer  
Entertainment
- » **Developer**  
Media Molecule
- » **Release**  
If you can make it,  
you can release it

After seeing the outstanding community levels in the original LittleBigPlanet, the sequel gave players a host of new creation tools, including the ability to make entire games. For LittleBigPlanet 3, Media Molecule is pulling out all the stops.

New features in the creation mode include a full suite of development tools, including support for Unreal Engine 3, Euphoria, and Havok physics. It also contains a dizzying array of modeling tools for 3D characters and environments. Direct C++ programming is not only supported, but required – as is a USB keyboard. The actual levels, however, can still be played with a controller.

Media Molecule's Alex Evans summed up the possibilities: "With a big enough team, you can create anything in this game. RPGs, first-person shooters, MMOs. We created a Missile Defense clone, and then created an actual missile defense system. Seriously, the U.S. Department of Defense is using it right now." » **Darth Clark**

## Tales Of What's Eating Gilbert Grape

Fat of heart



"I just hope I can have a nice funeral with no fire or anything."

- » **Platform**  
PC
- » **Style**  
1 or 2-Player  
Johnny Depp Movie
- » **Publisher**  
Anyone? Please?
- » **Developer**  
Telltale Games
- » **Release**  
Stretched out over  
several episodes until  
you just stop caring

Telltale, the studio responsible for adapting film classics *Back to the Future* and *Jurassic Park* into faithful adventure games, is taking a chance on another surprising project: the classic *What's Eating Gilbert Grape*.

These episodic quests recreate the touching 1993 Golden Globe-nominated film, telling the story of two dissimilar brothers struggling to find their place in the world while caring for their strict but well-meaning obese mother. The episodes will highlight key points in the movie, including a scene where players control Johnny Depp's character as he walks down a lonely dirt road, and another in which they must select dialogue options to talk his brother down from the water tower.

Despite the film having a running time of only 118 minutes, the game will be split into five individual chapters, each sporting two and a half hours of dramatic, heavy-hearted gameplay. » **Darth Clark**



PlayStation 3 • Xbox 360 • Wii • DS • PSP • 3DS • NGP • GBA

## Call of Duty: Ancient Warfare

After the commercial failure of the futuristic *Call of Duty: It's The Moon*, Activision is going back in time – way back. *Ancient Warfare* is set during prehistory's notorious Battle of the Cave Bear, and features all-new perks, era-appropriate bone weaponry, and customizable fur singlets.



3DS

## Red Dead Refrigerator

Years after his death, John Marston still has a score to settle... but when he comes back to Earth, his ghost accidentally gets trapped inside an old Frigidaire! This hilarious sequel is full of wacky disguises, comic mischief, hare-brained schemes, and all the hijinks fans loved from the previous entry.





## Heavy Rain: Before The Fold

All of the backstory, none of the problems

**Style** 1-Player Dinkin' Around Your House And Stuff  
**Publisher** Sony **Developer** Quantic Dream  
**Release** Delayed Until Next Month **ESRB** E10+

# 9

PlayStation 3

- » **Concept**  
Take what made Heavy Rain great, and remove the icky stuff
- » **Graphics**  
Every detail is faithfully rendered, from steaming muffin tops to the weave on Ethan's monogrammed towels
- » **Sound**  
Characters sound vaguely foreign, but not in that bad way
- » **Playability**  
You can press buttons and your guy does things
- » **Entertainment**  
As good as the Sims, without the breakneck pace or sense of progression
- » **Replay Value**  
So many replays

Heavy Rain was a pretty good game, but it had a major flaw: It was a complete and utter bummer. Quantic Dream has wisely shifted away from all of that depressing stuff about killers and sacrifices in this prequel, focusing instead on Ethan's past... and what a past it is! You learn exactly how Ethan Mars got his cool house (spoiler: he bought it), and the number of activities at his disposal is amazing. Between paying bills, walking up and down stairs, and answering telemarketing calls, it's a wonder Ethan has any time to spend with his sons Jason and Shaun and his awesome wife, Grace. If you enjoyed drinking orange juice in Heavy Rain, rest assured that the Mars family refrigerator is overflowing with multiple beverages. Fans of QTEs involving amputee farts to make babies laugh are in for a real treat. I can't wait to see what happens next to these characters! Well, except for all that bad stuff. » **Darth Clark**



## Sonic Reborn

Same hedgehog, new edge

**Style** 1-Player Nothing Else Works So We'll Try This Style  
**Publisher** Sega **Developer** Sonic Teamsters  
**Release** Who Cares? **ESRB** MMM

# 10

PlayStation 3 • Xbox 360

A lone figure staggers across the ruins of the Scrap Brain zone. His cheeks are caked in mud, and blood seeps through his mangled blue fur. He is vulnerable, but his green eyes still hold the spark of defiance that has entranced gamers since the early '90s. Behold the new face of Sonic the Hedgehog. This gritty reboot will have you questioning everything you thought you knew about Sonic. Reborn is about survival – not speed – and delves into an emotional portrait of what it means to be a hedgehog. After the Eggman Plague wipes out 80 percent of the world's population, the 19-year-old Sonic is left to fend for himself in the wasteland, fighting off hordes of robo-ghouls. The tension is thrilling, and fleeing isn't an option since psychological trauma prevents Sonic from ever breaking into a run. Forget spin jumps and loop-de-loops; as you search for tarnished rings (fragments of Sonic's fractured mind that represent a broken engagement), your only weapons are improvised shivs and your hedgehog wits. This makes Reborn the most mature Sonic to date, though giving Amy those double-Ds helps, too. » **Darth Clark**

- » **Concept**  
Follow in the rebooted footsteps of Tomb Raider and Devil May Cry
- » **Graphics**  
It's got lots of blood, so you know it's sophisticated. Also, the fur physics are impressive
- » **Sound**  
Nolan North voices every character
- » **Playability**  
Sonic's blazing speed is now a plodding limp, and it feels perfect
- » **Entertainment**  
This is Sonic as you've never seen him – starring in a good game
- » **Replay Value**  
Sure, knock yourself out

flowchart

### Racing Game Flowchart

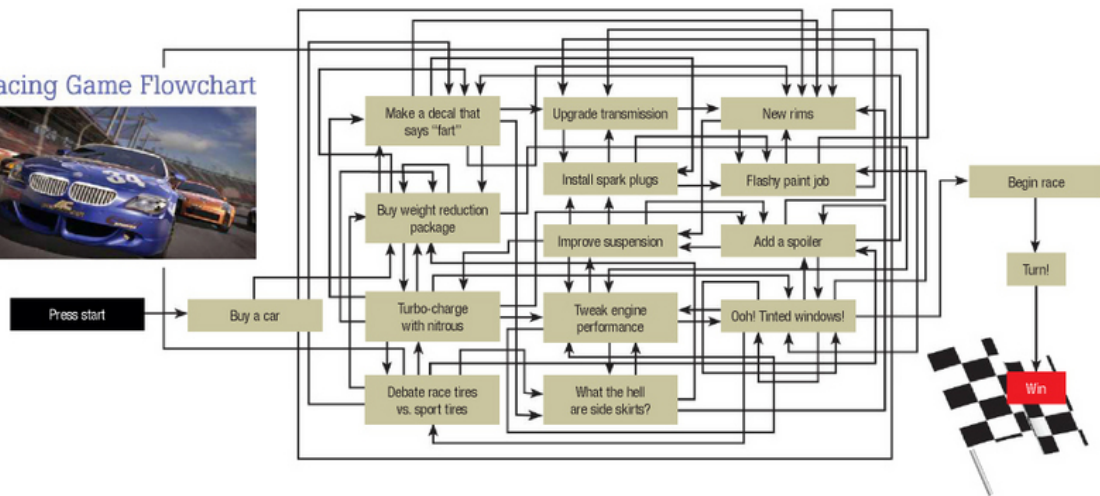

# interview



photo: Ed Gannon

# The Last of the Independents

In an industry that's increasingly divided between mega-publishers like Activision and EA and small, digitally focused independent developers, Atlus continues to thrive publishing physical copies of largely traditional Japanese RPGs. With a rabid fanbase and sensible business, the company has carved out a unique niche in the industry. We recently spoke with Atlus VP of sales and marketing **Tim Pivnicny** about the company's success and some of the recent changes in its focus.

## interview by Matt Helgeson

### In this industry, which is dominated by a few mega-publishers, what are the challenges of being a small, independent company?

Well, in terms of acquiring product, you're going up against companies that are bigger, more international, and have more money and feet on the ground looking for things. Over the last few years, we've stepped up our efforts to be more visible in the marketplace. We are talking to more companies about products. In terms of getting retail presence for our games, again, there are always the big guns out there that can afford high-priced in-store marketing and things like that. That makes it more difficult to get visibility in a store. However, the one great asset that a company like us has is having dedicated fans and some recognizable franchises that the fans love. Those retailers that can handle, in our case, Japanese RPGs, know that the pre-order business will be there. They know that the fans will be there on launch week and thereafter. There's a history of our games becoming scarce – not always, but often. We try to balance those things. We can't throw all the money at the marketing and we're generally not going to have the big licenses that cut across every demographic, so we try to stay within ourselves.

### You mentioned the fact that your titles often become scarce. What is your formula for deciding how many copies of a game to manufacture?

For the most part, we work very closely with our sales reps and accounts in advance to gauge the interest. We don't try to oversell our games or hype them too much. The most important customers that we have can help sell our products, they get a good feel for what the game can do. So, we round up all these numbers and take that and add in what we're doing in extra marketing or what we feel about the quality of the game. Can it have more legs than the typical game? Then, we decide what the launch quantity should be. Pre-orders are very, very important. We can look at that history to help gauge the interest.

### What's a successful title for Atlus in terms of sales?

That really differs a lot based on the licensing deal, and also the platform and retail price. If you ever look at NPD industry stats, you can tell how different games sell, but for us, some games will do 30-35,000, others will do two, three, or four times that. Sometimes, when all the planets line up, we have a really big game like *Demon's Souls*.

### Were you taken by surprise at the success of *Demon's Souls*?

Well, if taken by surprise means that nobody predicted it to be this big, we were taken by surprise. But we also felt, going into it, that it had a high probability of being our best title ever. It was also a risky title from a financial point of view, and the risk of doing something different from what Atlus normally does. It was a little scary. It was our first PS3 game. But as we dug in and began to understand what we had, we were definitely fueled by the fans that were playing the Asian version and talking about how great it was in the forums. Finally, when we announced it, they all rose up and supported it and got everybody jazzed. We made the right decision and dug in to do as good a job marketing it as we could.

### Was that one of the most expensive games you launched in the U.S.?

It's definitely up there. It wasn't apparent how big it could be right away, because we didn't build 200,000 or 300,000. We had significantly less than that. But, right away, every day we ordered more. Sony was doing a very good job of building and delivering – usually quicker than we thought the lead time was. Except for the first week, where everybody ran out of stock, we were in stock all of the time as orders came in with a few exceptions. Over the subsequent months, we really maximized the sales and satisfied every customer that wanted it. It was really fun, and we want to do that again.

### Namco Bandai is publishing *Dark Souls*, the successor to *Demon's Souls*, in America. Did the fact that you had so much success with *Demon's Souls* drive up the price for the sequel?

Well, I don't know for sure, but anybody with a sound-thinking mind would think that.

### Is that frustrating, as you took all the risk and helped establish the series?

Well, that goes back to one of the questions you asked earlier about what are the challenges when you're one of the smaller guys. But, yeah, that's frustrating.

### You specialize in bringing over games from Japan. What's the process for deciding which titles can be successful in America?

First of all, we're not just looking in Japan anymore. We're looking everywhere on Earth, and if there are other planets that have developers, we want to talk with them as well. We are stretching out. We're also looking at genres that wouldn't be considered a typical Atlus genre. But, in terms of what we look for, it's pretty simple. It's what most companies look for: the competitive environment, the developer's track record, what the cost is, the platform; all those related subjects. We don't go too far into a conversa-

tion if the game doesn't sound like fun or if the playable isn't fun. Using *Demon's Souls* as the extreme example, if you have a game that people love; it means it's going to sell more because word of mouth means a lot.

### You also doing more non-Japanese stuff aimed at core gamers like *Cursed Crusader* and *Divinity II*, which are European. Is that a response to the fact that the last few years have been pretty hard on the Japanese gaming industry?

Generally, yes. I wish we could make tons and tons of money on handheld games, but that's a little tougher here in North America. Many of the hits in Japan are handheld. The margins and price points are lower.

### Do you see more Western-developed games in Atlus's future?

We will maximize what we can get from Japan, but we will look elsewhere. We'll take a hard look at any game developed anywhere in the world.

### How closely do you work with Japan in terms of the games you bring over here?

Well, it's on a couple of different levels. One is, we can see into the future and see ideas and projects that are in the works. But, it really unfolds for us as they get closer to releasing the game in Japan. That's when they've gotten everything done that they want to do to launch the game over there, and are in a position to begin to help us. The timing generally works okay, because we have to go through the localization of it. That's not done overnight. It can take many months, depending on the game. That's when things start for us. The timeline is when they get ready to launch, that's when we start getting heavily involved in it.

### Is Catherine coming to the U.S.?

How do you spell that? [Laughs] We are planning on bringing *Catherine* out in the U.S. in summer of this year for PS3 and Xbox 360.

### How do you feel about digital distribution outlets like Xbox Live, PSN, and Steam?

Part of the process we're going through in investigating products is digital downloads across all platforms.

### Do you have ambitions to grow the company significantly or are you content with the niche that you have in the industry?

Well, number one, we want to be profitable. So, in terms of growing, yes, there's an interest in doing that. Our appetite was certainly whetted by *Demon's Souls*. So, while we spend a very good amount of our time looking at small, niche games – and we'll always love that business – we also carve out some time to look at some bigger possibilities. Our eyes are big and they are wide open. ♦

## CAREER HIGHLIGHTS

### 1982 THE BEGINNING

Pivnicny works as an electronics buyer for the retail chain Jefferson Ward

### 1985 THE NEW ERA

Pivnicny joins Hills Department Stores as a buyer. While there, he hears about Nintendo's 1986 test marketing of the Nintendo Entertainment System. In January of 1987, he meets with Nintendo. By April, Hills begins selling the NES nationwide, becoming the first mass retailer to sell the console.

### 1992 RENTING

Joining Blockbuster, Pivnicny joins pioneer the video game rental industry in the U.S.

### 1995 BIG CHANGES

After Viscon buys Blockbuster, Pivnicny joins the PC game publisher GTE Interactive, formally entering the game industry. GTE publishes such titles as *Titanic: Adventure Out of Time* and *TimeLapse*.

### 1999 PIONEERING THE CLOUD

Pivnicny joins the Internet startup Stream Theory, an early attempt at streaming, server-based online gaming and digital distribution. Many of the technologies seen today in businesses like *OnLive* and *Steam* were being done by Stream Theory at the time.

### 2002 DEVELOPING

Now at Sammy Studios, Pivnicny helps the American branch of Sammy develop U.S.-made titles. One of the projects is the dark western *Darkwatch*, which was eventually published by Capcom. Sammy also publishes *Spy Fiction* and *Iron Phoenix*.

### 2007 BACK ONLINE

Pivnicny does a brief stint at the online advertising firm HypeCouncil.

### 2007 BACK TO PUBLISHING

Eager to get back into gaming, Pivnicny joins Atlus at the behest of an ex-Sammy colleague, where he oversees sales and marketing for the company.

dear

# Fender Squier Stratocaster Guitar and Controller

*Fancy yourself a Rock Band 3 pro?*

Rock Band 3's premier accessory arrives months after the game, but like a true rock star

it makes an impressive entrance. For most users, the chief reason to buy the guitar is for its excellent game functionality. Superb detection on the fret board shows you which note you're holding down onscreen the instant you depress it, and the guitar detects which fret you're pressing even with a relatively light touch, which is crucial for beginners. Finger picking works well, but we recommend using a pick for the best detection.

The guitar works great in concert with Rock Band 3's excellent tutorials and growing library of Pro Guitar-enabled tracks. Don't expect this to give you a shortcut to becoming a guitar virtuoso; you still need to invest enormous amounts of time to learn the guitar. That said, the peripheral and the software combine to great effect, making the slow process much more fun than learning from a book or video.

On top of its Rock Band 3 functionality, the Squier doubles as a real electric guitar. It's essentially an entry-level option, but a decent one for the price. It has one knob for volume control, and only one pick-up. The custom polymer fretboard will feel strange to experienced guitarists, and the unit we tested had some consistent buzzing on certain frets. Even so, the guitar played and sounded good when we plugged it into an amp, and the solid Fender construction is light years beyond any existing guitar game controller. The Squier can also function as a MIDI controller if you have the necessary setup.

VERY GOOD 

**\$279.99**  
**(requires Mad Catz MIDI PRO-Adapter, \$39.99)**  
**fender.com**

by Ben Reeves & Matt Miller



1



## 1 PlayStation Move Sharp Shooter

The teams behind Killzone and SOCOM helped conceptualize this durable Move-compatible peripheral, which offers a more authentic shooting experience. The gun features a sturdy frame with an adjustable stock length and well-placed buttons. Sadly, it's not as precise as holding the controller in your lap and using fine wrist motions to aim. Plus, don't overlook the downside of arm fatigue after you hold a plastic gun aloft for a six-hour marathon session.

**\$39.99**  
AVERAGE

[us.playstation.com/ps3/accessories](http://us.playstation.com/ps3/accessories)

## 2 Mad Catz Marvel vs. Capcom 3 Tournament Edition FightStick

Mad Catz used to make the junk you had to buy if you didn't have the cash for an official peripheral, but the company has started delivering quality products in the last few years. Its Street Fighter IV Tournament Edition FightStick was one of the



2

3



4

best on the market, and Mad Catz has done it again for Capcom's next big fighting title. Both the PlayStation 3 and Xbox 360 sticks feature arcade-quality components sourced from expert Japanese manufacturer Sanwa Denshi, dual-turbo functionally for every action button, and a retractable 13-foot cable.

**\$159.99**  
EXPERTS

[store.gameshark.com](http://store.gameshark.com)

## 3 Razer Onza Tournament Edition Xbox 360 Controller

Razer's new controller is so soft and form fitting that your hand practically melts into it. Aimed at professional gamers, the Onza's most significant feature is its two adjustable analog sticks, which can be tightened to provide a higher level of precision. The backlit face buttons have a shorter throw distance than most 360 controllers, and the hyper responsiveness is a boon when you need to reload quickly or jump to safety. The rest of the controller features don't fare as well. With no wireless

support the Onza tethers you to your Xbox with a 15-foot braided cable, the d-pad is clunky, and the two remappable shoulder buttons are placed so close to the LB and RB buttons that you're bound to hit the wrong one when the action gets frenzied. Razer hasn't crafted the perfect controller, but if you're looking for precision analog controls the Onza is your best option.

**\$49.99**  
VERY GOOD

[razerzone.com/onza](http://razerzone.com/onza)

## 4 Dead Space Plasma Cutters

Epic Weapons has designed two life-sized models of Dead Space's plasma cutter — one version for each entry in the series. Made mostly of metal, these deadly sci-fi weapons come with their own display case and have both vertical and horizontal firing positions. They only fire gentle beams of light, but that should be enough to keep the necromorphs from coming out from under your bed.

**\$239.99**  
[epicweapons.com](http://epicweapons.com)

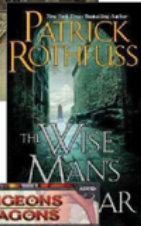

### THE WALKING DEAD: SEASON ONE

Based on the critically acclaimed comic series, this AMC series follows a crew who survived the zombie apocalypse. Unfortunately, the zombies aren't the most direct threat to their continued survival; they are

**\$49.99**  
[amctv.com/originals](http://amctv.com/originals)

### THE WISE MAN'S FEAR (KINGKILLER CHRONICLES, DAY 2) BY PATRICK ROTHFUSS

The sequel to 2007's award winning *The Name of the Wind* continues the story of Kvothe, an adventurer, arcanist, and famous musician who becomes a legend in his own time.

**\$29.95**  
[us.penguingroup.com](http://us.penguingroup.com)

### WRATH OF ASHARDALON: A D&D BOARDGAME

No dungeon master is required in this cooperative board game. Explore the tunnels beneath a raging volcano and hunt down the dragon inside with up to five players.

**\$64.99**  
[wizards.com/dnd](http://wizards.com/dnd)

### ZITA THE SPACEGIRL BY BEN HATKE

When a mysterious red button crashes on Earth, Zita pushes it, only to get transported to a magical world where she becomes a hero. This imaginative graphic novel is sure to delight everyone's inner child.

**\$10.99**  
[firstsecondbooks.com](http://firstsecondbooks.com)

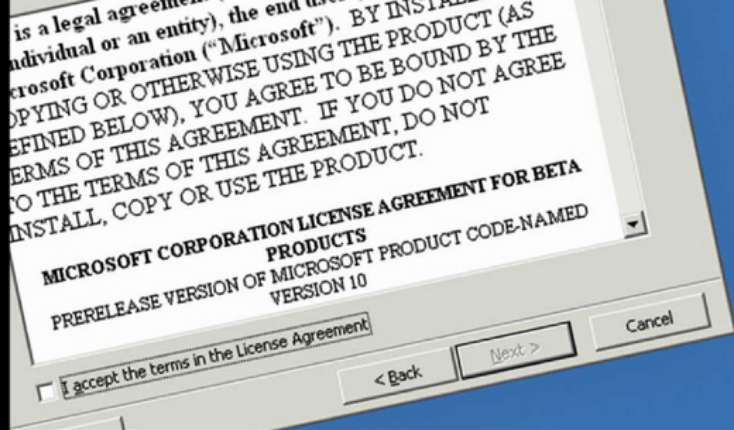

by Matt Miller  
senior associate editor,  
Game Informer

# The Fine Print

## End User License Agreements: Can't Read Them, Can't Game Without Them

I'm sick of end user license agreements. A few weeks back, I excitedly popped DC Universe Online into my PS3, looking forward to diving into some superhero craziness with a few of my buddies here at GI. What's the first thing that greets me? A legal contract that would put my house mortgage to shame.

What are these things, anyway? Terms of service contracts are a legal agreement between you and the company that makes or sells the game or product you're using. You see them most commonly with games that have an online component. They tend to set up a lopsided structure that favors the company's rights over yours and helps assure that you will not use the software in a way they don't want you to.

I get it. Companies need to protect their intellectual property. But is this really the way to do it? In a recent poll on [gameinformer.com](http://gameinformer.com), we asked our readers whether they ever actually dig in to read those lengthy missives penned by lawyers for some distant game company. The answer? 67 percent said they never give them a second glance. Less than 2 percent of respondents said they actually read them completely. Despite any misgivings, we scroll to the bottom, tap the "I Accept" box, and head on in to our beloved game. So it's our fault if we didn't read it, right?

Well, the matter is at least up for debate. Last year, an intriguing case went before the courts. In *Vernor v. Autodesk*, a man bought a few copies of an AutoCAD imaging program at a garage sale, and then tried to resell that software on the Internet. Autodesk threatened to sue him, claiming that not only did he not have the right to sell the product, but neither did the original owner. Why? Because the end user license agreement only licensed the software to the buyer. Neither buyer ever actually owned it.

What? He bought it, right? How can he not own it? The district court seemed to agree that

something was fishy, and it ruled in Vernor's favor. Sadly, an appeals court reversed the decision, and ruled for Autodesk.

Even ignoring the issue of the license versus ownership debate, this seems a little ridiculous. The "buyer" had no reasonable way to understand that he didn't actually own the product in question. End user agreements are couched in so much legalese that even a trained attorney would have trouble parsing what they have to say. That's the problem. Even if we did want to read and comprehend these agreements, most of us can't without an advanced legal degree. Nonetheless, we're held legally accountable to its contents. By hiding behind obscure and incomprehensible language, software developers and publishers create a nearly impenetrable barrier between themselves and the gamers that enjoy their titles. Even if I did read the 30 paragraph agreement you made me sign, I wouldn't know if I was breaching the agreement if I wanted to.

For some people, I'm sure this couldn't be less of a problem. Agree to the nonsense statement, and move on. What's the big deal? It just bugs me. When I agree to something with my name attached to it, I like to know what it's saying, or at least have an expert I trust give me the go ahead.

End user license agreements in their current form aren't the answer to IP security for a few reasons. First, there are little to no protections for consumers. In a world where people increasingly purchase games, music, movies, and other entertainment digitally, there should be

increased rights for the consumers of those products, not less. Would you put up with a brick and mortar store that made you sign a 10-page legal document before picking up a new sweater?

Second, these agreements are fundamentally incomprehensible to the average human being. How can I be held accountable to a document I can't understand? For now, the courts seem to think I can. So long as that's the case, no one should expect that software companies are going to change their approach.

In 2009, Congress passed the Credit Cardholders' Bill of Rights. While few would claim this bill was perfect, it did put into place some basic protections for credit card use, including disallowing CC companies from changing a user agreement without advance notice. Sadly, similar protections do not exist for software users. Software agreements change all the time, but in many cases after the first few weeks of owning the product, you can't return it if you decide to decline a new agreement. That's presuming you could even understand what has changed.

There's also the way these agreements back gamers into a corner regarding the functionality and lifespan of the game. Most agreements don't guarantee service, and absolve game makers of delay or failure of servers. When you accept the EULA, you agree that the publisher can turn off its servers at any time without notice.

Just once, I'd like to turn on a new game and read a user license I could understand. Maybe five or six rules – things like: Don't steal our game. Don't use the game to make real world money. Don't harass other players. The sort of thing I could read in a few minutes, and agree to with my eyes open.

But I think the agreements are so long and perplexing exactly so that we can't do that. Make something convoluted enough, and no one will take the time to figure it out. Like the recent financial instruments that caused the mortgage meltdown here in the United States, it's easy to overlook something that's too complicated to comprehend. Admittedly, we're not talking about the fate of the free market here. We're just playing some video games. But a little transparency and simplicity couldn't hurt, whether you're talking about the contract for a house or the ability to enjoy your favorite MMO.

*The views and opinions expressed on this page are strictly those of the author and not necessarily those of Game Informer or its staff.*

If you work in the industry and would like to share your opinion, contact senior editor Matt Helgeson at [matt@gamenformer.com](mailto:matt@gamenformer.com)

# 2K SPORTS TOPSPIN 4 MEET YOUR MATCH



## HOW DO YOU MATCH UP AGAINST THE BEST PLAYERS IN THE WORLD?

COMPETE WITH 25 OF THE BEST PROS AND LEGENDS  
IN ONE OF THE MOST AUTHENTIC TENNIS SIMS EVER MADE

**AVAILABLE NOW**



©2005-2011 Take-Two Interactive Software and its subsidiaries. All rights reserved. Top Spin, Top Spin 4, 2K Sports, the 2K Sports logo, and Take-Two Interactive Software are all trademarks and/or registered trademarks of Take-Two Interactive Software, Inc. All Rights Reserved. The ratings icon is a trademark of the Entertainment Software Association. All other marks and trademarks are properties of their respective owners. All Rights Reserved.



**MEET YOUR MATCH  
AT FACEBOOK.COM/TOPSPIN4**



01.1



01.2



05  
Conduit 2



08



12  
MotorStorm Apocalypse



15



18



19.1

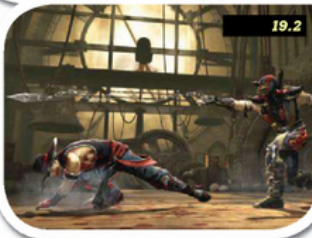

19.2

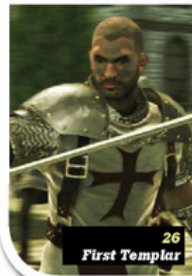

26

First Templar

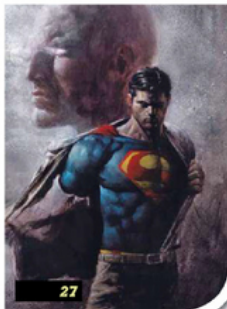

27



29

## April

### 01.1 Maggie With A Beard

Computers can do anything! They can fly airplanes, talk to satellites, and even print receipts. In the not-so-distant future they will allow you to relive the last eight minutes of someone's life, as depicted in today's theatrical release, *Source Code*. If the totally plausible story doesn't have you sold, Jake Gyllenhaal's starring role might be worth the ticket. We loved him in *Secretary*.

### 01.2 Super Heroes Living In Fear

Starting this month and running throughout the summer, Marvel Comics is kicking off "Fear Itself," an event that will touch the lives of almost every hero in the Marvel universe. As the name of this story implies, Marvel's heroes will confront their greatest fears... which are probably clowns, spiders, or MODOK wearing a bikini.

### 05 New Releases

- Conduit 2 (W)
- End of Nations (PG)
- Top Gun (PG)

### 08 Medieval Herbs

If you watched the brilliant *Pineapple Express*, you know that James Franco and Danny McBride are a hilarious duo. Their new project *Your Highness* opens in theaters today. The film's title has multiple interpretations. It can refer to royalty, skydiving, temperatures, blood pressure, and that's about it.

### 12 New Releases

- Dance Dance Revolution (360)
- Divinity II: The Dragon Knight Saga (360)
- Fantastic Pets (360)
- John Daly's Pro Stroke Golf (360)
- Michael Jackson: The Experience (PS3, 360)
- MotorStorm Apocalypse (PS3)
- Squirrels (DS)

### 15 Never Go Upstairs

Any self-respecting horror fan knows *Scream*. Wes Craven's masterpiece rewrote the rules for slasher movies, but the series went dormant after two sequels. Today, *Scream 4* attempts another genre overhaul, complete with old-school cast members like Neve Campbell and David Arquette. We don't want to ruin the plot for you, but here's a little spoiler: A bunch of teenagers are going to die. Horribly.

### 18 Take An Early Nap

*Portal 2* and *Mortal Kombat*, release tomorrow! You're going to be gaming for the next 48 hours straight, so make sure you are well rested. Take a nap whenever your boss isn't looking, and hit the sack around 5 PM so you're wide awake for your midnight drive to the game store. Warning: Disregard our nap advice if your job involves driving, deep fryers, Superman, or last-minute video game bug testing.

### 19.1 A Day of Cooperation

The hardest decision you face today is not whether to call in "sick" to work (you should), it's whether you should play *Portal 2* alone or cooperatively. If your friends are true *Portal* fans like you, they also look the day off, so you may as well team up. If your partner starts irritating you by making stupid decisions...

### 19.2 A Day of Competition

...work out your frustration with a few rounds of *Mortal Kombat*. Nothing brings friends closer together than taunting each other apart. This is a proven scientific fact, and is completely healthy. It worked for Kratos and his dad!

### 26 New Releases

- First Templar (360, PG)

### 27 Action Comics Turns 90!

Today marks the release of *Action Comics' 900th* issue. We don't know what this story holds for Superman, but if this issue's cover is any indication, he's working as a Chippendale dancer. This historic issue features the writing talents of Paul Cornell, David Goyer, Richard Donner, and Damon Lindelof.

### 29 Still Fast And Furious

What do Vin Diesel, Dwayne "The Rock" Johnson, and Paul Walker have in common? Their careers took recessives when they tried to become real actors. Now they are going back to what they do best: taking off their shirts, spouting off one-liners, and pandering to the MTV audience. See their well-oiled chests behind the wheel in today's theatrical release *Fast Five*, yet another *Fast and Furious* sequel.



# SUPER STREET FIGHTER 3D EDITION



## LET'S TAKE THIS OUTSIDE

Get Super with the ultimate version of Street Fighter®, now in face-punching 3D. Perfected for Nintendo 3DS™, WI-Fight your way with all 35 characters using local and online multiplayer. Enjoy new visual perspectives, new modes, and so much more.

[www.facebook.com/streetfighter](http://www.facebook.com/streetfighter)

[www.streetfighter.com](http://www.streetfighter.com)



CAPCOM®

NINTENDO 3DS

» Platform  
PlayStation 3  
Xbox 360 • PC

» Style  
1-Player Action  
(2-Player Online)

» Publisher  
THQ

» Developer  
Volition

» Release  
Holiday



# EMBRACING THE CRAZY



# SAINTS ROW

## THE THIRD

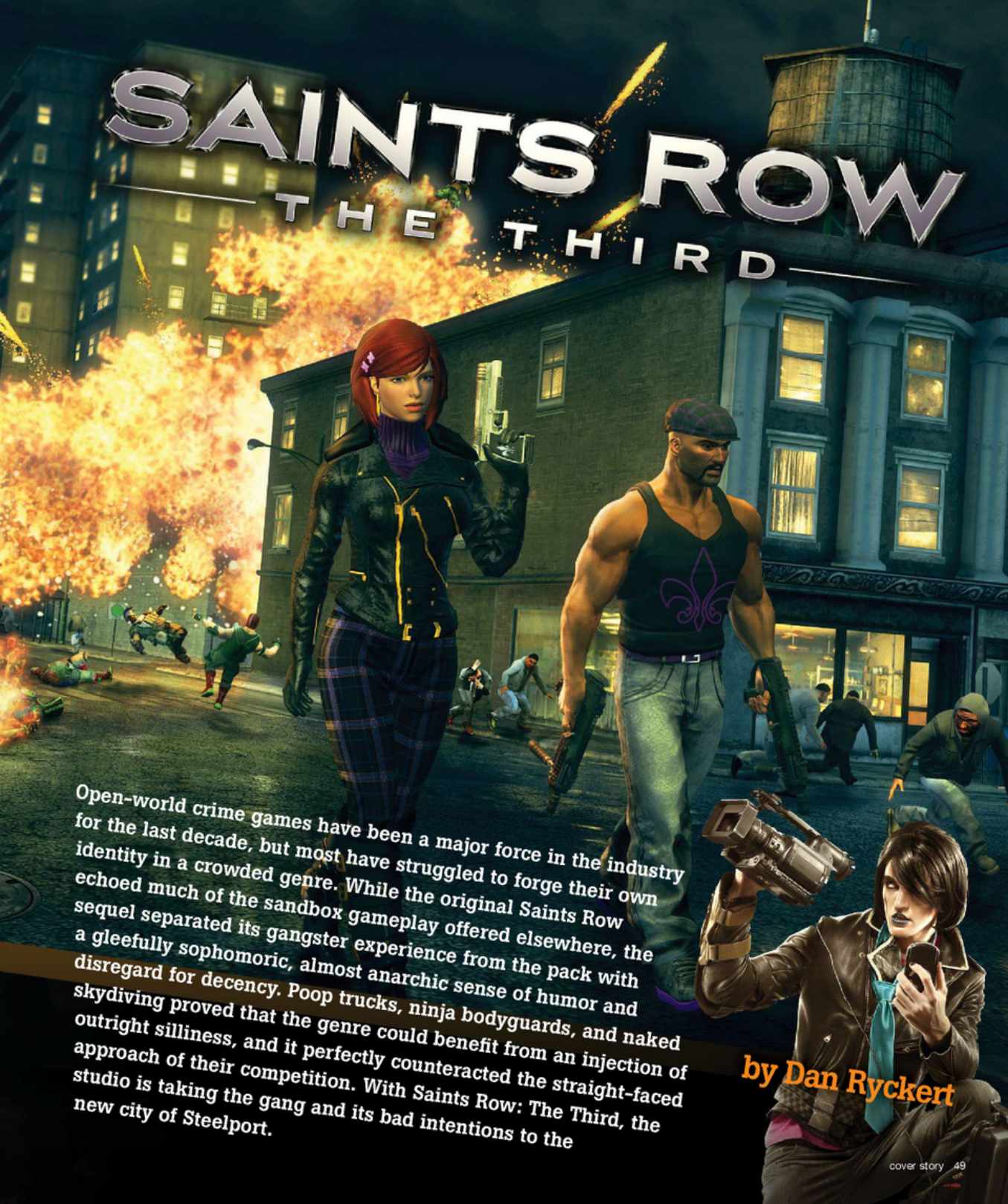

Open-world crime games have been a major force in the industry for the last decade, but most have struggled to forge their own identity in a crowded genre. While the original Saints Row echoed much of the sandbox gameplay offered elsewhere, the sequel separated its gangster experience from the pack with a gleefully sophomoric, almost anarchic sense of humor and disregard for decency. Poop trucks, ninja bodyguards, and naked skydiving proved that the genre could benefit from an injection of outright silliness, and it perfectly counteracted the straight-faced approach of their competition. With Saints Row: The Third, the studio is taking the gang and its bad intentions to the new city of Steelport.

by Dan Ryckert

The 3rd Street Saints used to be just another group of thugs with Glockes and itchy trigger fingers, blasting their way through the city of Stilwater's countless gang wars. Fast forward a few years, and the boys in purple have buried their rivals and even formed a marketing partnership with the gigantic Ulkor Corporation. After ridding the streets of numerous gangs, the Saints are heroes of these once-treacherous neighborhoods. They pose for pictures with kids, sell t-shirts and bobbleheads, and even have an actor embedded in their ranks so he can prepare for his role in a movie about the gang's exploits. Like former gangsters Snoop Dogg and Ice-T, the Saints became a mainstream presence. While the public sees them as guardian angels who only want to keep the streets safe, the group can't quite shake their roots as thieves, dealers, pimps, and soldiers. These instincts inadvertently take them out of Stilwater and into new territory.

With no competition left in Stilwater, the Saints run wild like kids in a candy store. Robbing banks is a common activity for the group, and that's where you kick off Saints Row: The Third. In typically bold fashion, your crew attempts to score some quick cash by airlifting a bank vault out of the ceiling via helicopter. Things go awry and the Saints end up in the slammer, surprising many considering the cops are normally bribed to avoid public busts. While incarcerated, you learn that an international crime ring known as the Syndicate owns the bank in question, and they're none too pleased with the Saints' act of aggression. After slipping the cops substantially more cash than your crew could pony up, the Syndicate holds you and partners in crime Johnny Gat and Shaundi hostage on their private jet. The three of you awaken to the sight of a cigarette-smoking Belgian named Philippe Loren, flanked by his femme fatale assassins Viola and Kiki. An offer is presented – the Saints will be allowed to live in exchange for 66 percent of their monthly profits. Unsurprisingly, your character retorts by saying, "Go make yourself a f---ing waffle" and a gunfight breaks out onboard the aircraft.

At this point you take control of your character, securing human shields and blasting your way towards the cargo bay at the rear of the plane. After dropping several of your captors, the cargo doors open and dozens of the gang's cars (and bodies) begin to fly out into the night sky. You grab a parachute and struggle to hang onto solid ground, but an SUV tumbles past and sends you and Shaundi hurtling toward the ground. Gang warfare didn't properly prepare your character for this particular situation, but his instincts tell him to act quickly and secure a weapon. Controlling your character as he plummets through the sky, you steer him towards an airborne Syndicate member. Upon reaching him, you pummel him in mid-air with blows to the head and steal his double Uzis. You're not the only free-faller with survival instincts in high gear, however, as Syndicate members are firing at you from every angle. While avoiding debris and falling cars, you kill your enemies and manage to catch up to Shaundi. You deploy your parachute, and the girl seems appropriately impressed with this act of extreme bravery.

This mission's already featured more action than any previous Saints game, so we expect the protagonist and Shaundi to float to the ground followed by a nice end-mission reward. However, Volition prefers to layer crazy on top of crazy, so the plane begins a slow 180-degree turn in an effort to ram the two of you during your descent. Abandoning the role of gentleman, your character tosses Shaundi toward the ground and attempts to break through the window of the oncoming plane. You manage to shoot your way into the cabin, but aren't able to gain solid footing long enough to go after Philippe. Instead, you fly out the back of the aircraft and attempt to save Shaundi once again. She understandably berates you for throwing her to a certain death, but you land safely and the mission ends.



Volition cites the Clive Owen flick *Shoot 'Em Up* as one of their primary influences



Previous Saints games featured sprawling stories, but you'll have a primary antagonist this time around in the form of Philippe Loren



## A City In Turmoil

After touching ground in a new city and assessing the situation, your character realizes he can't return to Stilwater with the powerful Syndicate controlling the banks and police force. He instead calls up some key Saints, prompting a mass migration to this new town of Steelport. It's probably for the best, as virtually all of Stilwater was covered in sewage, set on fire, or blown up in Saints Row 2, and its entire population is likely rendered infertile thanks to countless blows to the groin.

For years prior to the Saints' arrival, Steelport suffered from a constant economic decline. Founded by blue-collar factory workers, elements like proper zoning were a foreign concept during the city's conception. City planners built skyscrapers adjacent to warehouses and ignored the benefits of mass transit, and the city gradually decayed over time. Stilwater featured suburban areas with white picket fences and freshly mowed lawns, but the closest comparison in Steelport is a section of densely packed, rundown one-story houses. The Saints aren't the only organization with its eye on Steelport; the Syndicate smells an opportunity and begins taking over the weakened city. They renovate slums with gaudy casinos and brothels, but the lure of sin and vice clearly takes precedence over appearance. You won't find glitz and glamour in these areas; they

prey on a beat-down populace's weaknesses and addictions. In an environment such as this, the city's worst comes into full focus. If Stilwater had a serious gang problem, Steelport has a full-blown epidemic.

With new territory comes new threats, and the Syndicate's extensive influence permeates every corner of Steelport. In addition to his role in the Syndicate's leadership, Philippe Loren recruits hundreds of psychopaths to three different gangs in the area. Morning Star (personally led by Philippe) are suit-wearing, chain-smoking European baddies straight out of a Bond film. They peddle weapons and prostitutes, and prefer sniper rifles and SMGs when deadly force is required. If Morning Star are the brains of the Steelport gang scene, the Luchadores are the muscle. Patrolling the southwest area of the city in their SUVs, these masked wrestlers deal drugs and run gambling rings. If you get on their bad side, they're prone to heavy weapons and close quarters combat. Finally, the Deckers are the computer nerds of the bunch, dealing with security and money laundering. As the gang wars intensify, another faction will arise – the STAG (Special Tactical Anti Gang) unit. This government-sanctioned force is tasked with ridding the streets of any gang they encounter, regardless of whether they're Syndicate or Saint.

If the missions we've seen are any indication, Saints Row: The Third is even more chaotic than previous installments. Carnage can be a great thing, but not if it comes at the expense of playability. Volition has specifically designed the city to include numerous landmarks that clue you in on your location without the need to constantly stare at the mini-map. Casinos and SUVs driven by wrestlers indicate the geographical location in a more interesting manner than some color on a map screen. Volition specifically designed Steelport's skyline so it can be seen from almost any area of the city, so you always know which direction is downtown. Great fictional locales like Gotham City and Metropolis become just as important characters as any super-villain, and Volition wants to make Steelport equally vital to Saints Row: The Third.



## Drawing The Line

With so many brazenly juvenile opportunities, where does the team draw the line of decency in Saints Row: The Third? "It's like defining porn. I can't define it, but I know it when I see it," says senior producer Greg Donovan. "Not every crazy weapon idea that gets thrown out at meetings ends up getting used. With some ideas, we're like 'That's not over the top...even we know that's distasteful' to the point where I don't even want to tell you what the ideas were. Put it that way."

After prying, Volition revealed one rejected idea – the fart in a jar. As the name implies, this weapon would consist of a concentrated blast of flatulence contained within a glass jar. After throwing it at a group of enemies, they'd become so nauseated and disgusted that they'd vomit all over the place rather than engaging you in combat. Some members of the team loved the idea, but others weren't so keen on a flying fart bomb, and the idea was scrapped.

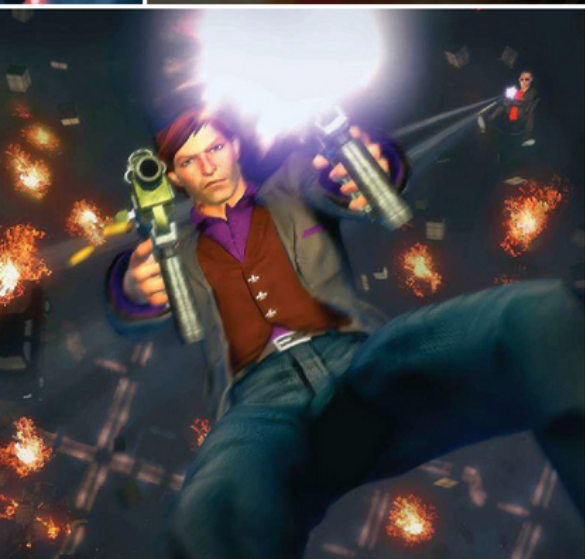



## It's About Respect

Saints Row: The Third is the first game in the series to feature a standard leveling system. If you wanted to upgrade your accuracy, weapon damage, or sprinting ability in previous games, you had to complete all levels of a specific activity. This time around, respect works exactly like XP. Earn enough respect and you'll rank up, which unlocks a new collection of perks and abilities for purchase. If you avoid melee combat, you can bypass those upgrades and save cash for weapon-based perks. With player choice being such a big focus in Saints Row: The Third, this new system allows you to upgrade your character the way you want.

## The Saints Go Marching In

Previous Saints Row titles featured similar three-gang structures, but each organization had distinct story arcs that rarely intersected. In an effort to create a more cohesive narrative, characters from each gang in Steelport interact with each other and are featured in other gangs' stories throughout the game. The manner in which you interact with these gangs and make decisions during missions will impact your experience in significant ways. At one point in the story, the Saints come into possession of a gigantic bomb. The Syndicate owns a towering skyscraper, and blowing it up would earn you a ton of respect [see sidebar]. "Your choice will affect both the skyline of the city and how people in the city react to you. People are gonna talk about it... this giant f---ing building just blew up," says designer Scott Phillips. If you'd rather preserve the Steelport skyline, you can lead an assault on the tower from the inside and take it over for yourself. With this tower under Saints jurisdiction, it gives you access to more weapons and cash, and becomes your new base of operations.

Smaller decisions also play a role, such as a mission where the Saints raid a Morning Star boat filled with prostitutes. After capturing it, you can either sell their boat back to them for one lump sum, or keep it for yourself and pimp the girls out for the Saints. The instant cash-in vs. long-term investment concept is similar to the options lottery winners receive, and can reward patience if you're willing to turn down the large initial payout.

Bringing down Morning Star, the Luchadores, and the Deckers requires more than accepting a bunch of story missions. Various flashpoints scattered throughout the city feature the Syndicate gangs partaking in their favorite illegal activities. One involves a group of over 20 Luchadores guarding a shipment of drugs, and it appears entirely out of the context of any mission or activity. By calling in an air strike, it's possible to send their flaming bodies scattering in every direction.

Aggressive actions such as these earn you respect, but they're also a crucial element to taking over the city. You can take several different approaches to overtaking an area, and there's no one right way. Destroying flashpoints helps the Saints move into new turf, but purchasing shops, completing activities, and taking over strongholds also gets you closer to dominating Steelport.

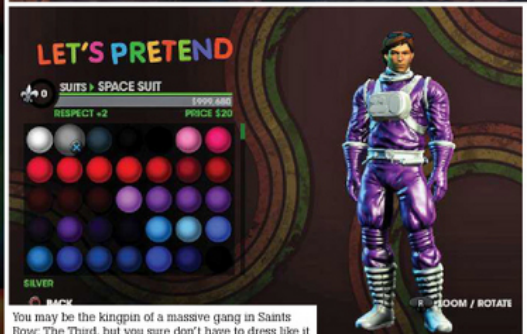

You may be the kingpin of a massive gang in Saints Row: The Third, but you sure don't have to dress like it.





The scariest costume option is undoubtedly the Purry

## Anatomy Of An Empire

Even though Volition has taken several steps towards a more cohesive story, it still prefers for players to create their own character rather than provide one with a predetermined look and background. Your character is the same protagonist from the first two games, but you're free to change his or her entire appearance at any time thanks to the Image As Designed plastic surgery locations. Customization options are even more robust than in previous installments, so you can easily cause havoc as yourself, a celebrity, a fictional character, or a superhero. Triangle sliders streamline the process, and new skin color options ensure we'll see a few Incredible Hulks running around Steelport. YouTube videos showcase fans in Saints Row 2 causing trouble as rappers and the team of Will Smith and Martin Lawrence from *Bad Boys*, and Volition has hinted at an online community system that allows players to share their creations.

Every gang needs some signature rides, and you can tweak the cosmetics and performance of your automobile of choice. Instead of being limited to nitrous or kneecappers, players can upgrade bumpers for added durability or pour some cash into torque to help outrun the cops. If you really want your car to stand out, add gigantic spoilers or a customizable underglow. Don't worry about losing your investment if you wind up careening into the ocean, as your rides can always be retrieved and repaired at your crib.

Saints Row 2 allowed you to customize your entire gang if you were tired of the thug life aesthetic. You could class things up a bit by having your crew wear suits, or make a ridiculous game even more surreal by having hundreds of ninjas drinking 40s and patrolling around town. Rather than sticking with one uniform look, in Saints Row: The Third players can mix and match four different outfits for your Saints. With these new options to diversify, you can turn the streets of Steelport into a parade of furies, pirates, S&M gimps, and the mascot for the Saints Flow energy drink.

You may find dozens of these customized gang members on the street, but one character stands out in the crowd. At over eight feet tall, Oleg Kirilov is a towering beast who can toss cars like they're made of styrofoam. He'll eventually be an asset to the Saints, but the Syndicate captures him in an effort to create a clone army. Oleg is highly intelligent, but the Syndicate's cloning process proves imperfect and his copies come out dumb as bricks. Despite their lack of brains, they're still shipped out as cheap muscle to the gangs of Steelport. After getting used to taking down waves of standard-sized, gun-wielding baddies, you'll have to shift your strategy when one of these cloned brutes charges you with piledrivers on his mind. Unloading shells into him will weaken his defenses, but you have to complete a quick time event to deliver the final blows. If your Oleg is in the same room, a battle of the titans plays out like a Hulk vs. Abomination duel. Your version of Oleg is the chess-playing original (known as "Patient Zero"), so you have both brains and brawn on your side.

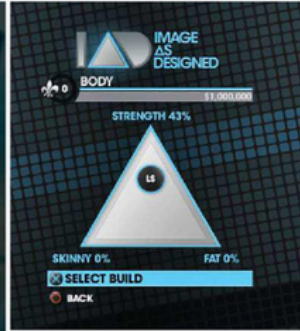

## Narrowing The Focus

Both previous Saints games featured competitive multiplayer modes, but they weren't nearly as popular as the main story. Because of this, Volition scrapped competitive multiplayer for Saints Row: The Third. "The majority of people wanted the single-player and co-op experience, so we're focusing on blowing that out of the water," says senior producer Greg Donovan. While you can't take on the competition in Big Ass Chains or Strong Arm anymore, co-op returns. Every mission and activity can be enjoyed with a friend, with full drop-in and drop-out support.

## Shoot To Thrill

Oleg won't always be around, so you'll need an arsenal of weapons. The typical assortment of pistols, SMGs, rifles, and grenades is back, but a wide variety of less traditional tools of destruction are also at your disposal. One melee weapon – a giant bat shaped like a certain sex toy – leans far towards the novelty end of the spectrum. This floppy rubber weapon is fully animated and endowed, and adds an unmistakable degree of insult to an attack. Beating an elderly woman with a sledgehammer is typically frowned upon, but you're really pushing the lines of decency when you're pummeling her with a purple phallus.

A sex toy might be good for a laugh, but it doesn't do much good when faced with an angry mob of Morning Star. When overwhelmed, players can call in an airstrike by painting the target area with a laser. The ensuing explosion turns any flesh within a large radius into ashes. If your enemies are camped under an awning or other cover, you can opt for a Predator drone. Like the iconic AC-130 level in Call of Duty 4: Modern Warfare, this changes your perspective to a top-down view. You can pepper areas with standard bombs or release a smart bomb that can be precisely controlled with the analog sticks.

Attacking from the air is great for keeping your character out of harm's way, but there's another way to mount an attack without ever stepping into an enemy's crosshair. The RC gun shoots out an electronic bug that allows you to control vehicles. It starts with the ability to control cars, but you can eventually upgrade it to take over tanks and air vehicles. Once the bug is attached, you assume full control of the vehicle just as you would if you were inside. Want to deliver an explosive package to a gang? Attach satchel charges to a station wagon, take it over with the RC gun, and drive it into enemy territory. The detonation will take out a good chunk of your rivals (as well as the unfortunate driver) without putting yourself in danger. If you'd rather get a gang into trouble than murder a large quantity of them, simply take over one of their cars and ram it into a police vehicle. It may not make much of a dent in their control of the city, but watching the confused driver get chased by the cops is good for a laugh.



## Steelport's Scumbags



### Phillippe Loren

This elegant and poised Belgian is the leader of Morning Star, the oldest of Steelport's three gangs. He specializes in international arms deals, and was responsible for recruiting members of the Luchadores and the Deckers. He's not happy about the Saints' attempt to steal from his bank, and he'll do anything in his power to keep them from taking over Steelport the way they did Stilwater.

### Viola and Kiki DeWynter

After graduating from business school at Harvard, these femme fatales joined Phillippe and began managing the Syndicate's finances. These sisters are expert assassins and operate as the right hand of the organization. Their cool demeanor, business savvy, and deadly aim ensure that they're the heiress apparents to the Syndicate.

### Killbane

Banished to Mexico after killing a man inside the ring, this luchador returned to America in an effort to reclaim his lost fame. Obsessed with his legacy, this temperamental giant rules over the southwest's Luchador gang. While he can turn on the charm during a media interview or business meeting, his violent nature can manifest itself at a moment's notice.





## Maximizing Destruction

Customizing your character, cars, and gangs are staples to the series, but *Saints Row: The Third* is the first installment to offer upgradable weapons. If you're a fan of assault rifles, you can add a sniper scope and underbarrel grenade launcher. Close combat more your style? Add a third barrel to that lame old shotgun and you've got yourself the Gravedigger. Like the cars, don't worry about losing your investments when you switch weapons or run out of ammo. Upgraded guns are permanent fixtures in your weapons cache, so you can wield a massive amount of firepower by game's end. Take a look at a few of the weapons and how they look after you pour some cash into them.



### Matt Miller

The leader of the Deckers, Miller is treated like a god on the Internet. Like a message board troll, he's loud, confident, and obnoxious. This hacker may talk a big game online, but Miller's inexperience and social awkwardness become apparent when the guns are drawn and he's forced to deal with reality.



### Angel De La Muerte

Angel is Killbane's high-flying former tag-team partner. They moved up to Steelport and temporarily ran the Luchadors together, but Killbane's jealous nature resulted in a falling out. After he was publicly demasked by his former friend, Angel fled the city and went into hiding. Losing your mask as a luchador is seen as a serious mark of shame, and this former star becomes afraid to go out in public. With a common enemy in Killbane, Angel eventually becomes an asset to the Saints.



### Zimos

This smooth-talking, chain-smoking charmer is the oldest pimp in Steelport. After a tracheotomy, Zimos was fitted with a voice box that emits every word he says in T-Pain-quality autotune. His slick ways led to a friendship with the icy DeWynter sisters, but they eventually had a falling out. The Syndicate responded by locking him in the basement of one of their human trafficking operations, prompting the Saints to come to his rescue. After a daring escape involving a gimp suit and a rickshaw, Zimos befriends your crew and provides information regarding the city.

**Saints Row:** The Third features a wide arsenal of weapons, but they all have one feature in common – a specific animation for nut shots. Hold a pistol as you melee a bum and your character will drop to one knee and throw stiff jab at his crotch. If you're wielding a bazooka, you'll perform a golf swing that connects squarely to the family jewels. We've never seen a game treat testicular torture so lovingly; it's nice to see Volition appealing to the 12 year-old in all of us.

One tedious aspect of open-world crime games is waiting for the repetitive carjacking animation to complete. The last thing you want to do when you're on the run from the cops is wait for the door to open, the driver to be pulled out, and your character to get ready to drive. In *Saints Row: The Third*, the LB button acts as a sprint button as well as a modifier. Volition refers to it as the "awesome button" because it amplifies almost any action you do. In the case of carjacking, this shortens the process down to a missile drop-kick into the driver's seat. Sprint at the car from the side and you'll break through the window, sending the driver flying out the opposite door.

Approach from the front and you'll leap over the hood, giving the driver a face full of boot. If you'd rather stick with traditional means, the camera zooms in on your victim as you shoot them in the face point-blank or repeatedly slam the door on their head.

Like many modern games, *Saints Row: The Third* gives grenades their own dedicated button rather than lumping them in with the rest of the weapon selection wheel. Pressing the right bumper tosses a grenade (or other selected explosive) in the direction you're facing, regardless of your current primary weapon. This functionality takes the place of food on the radial selection wheel, so you won't be scarfing down burgers or malt liquor during gang wars anymore. Since this was the go-to method for health recovery in previous games, Volition is softening the blow by decreasing the time it takes for your health to recharge. We'll miss the visual of our character snacking on chicken nuggets while surrounded by explosions and gunfire, but it's a fair trade if it means we can toss a grenade whenever we want.

## Good Dumb Fun

In a time where the "games as art" debate is more prominent than ever, many journalists rely on comparisons to film. We may hope for our industry's *Citizen Kane*, but the movie industry has still found time to give us stupid fun like *Dumb and Dumber* or *Tommy Boy* amidst its Oscar contenders. Striving for high art is a noble effort, but there will always be a spot for crass humor and comic violence. *Saints Row* does a splendid job filling that role. It was at its best in *Saints Row 2*, with the ludicrous Insurance Fraud, FUZZ, Septic Avenger, and Trail Blazing activities. Whether you were spraying poop on an elderly couple in the park, chainsawing a man in half for littering, or driving a flaming ATV through a college campus, these wacky moments were impossible to play without a grin on your face. Here are some of the new activities you can look forward to in *Saints Row: The Third*.

### Professor Genki's Super Ethical Reality Climax

This warped activity mixes elements of the wackiest Japanese game show you've ever seen with the awesome 1987 Arnold Schwarzenegger vehicle *The Running Man*. Players compete with other sociopaths in a reality show sanctioned by the Syndicate featuring fire traps, weapon drops, mascots, and hyperactive Japanese announcers.



### Tank Mayhem

Fans of *Saints Row 2* are used to Mayhem missions, which equipped you with numerous weapons (usually with infinite ammo) and had you destroy as much property as possible. This was fun, but most attempts turned into long stretches of throwing grenades at fences. Tank Mayhem mixes things up by placing you into (surprise!) a tank and tasking you with destroying specific high-value targets. These sections put the game's technological improvements on display – cars warp and deform as your tank makes contact rather than simply exploding in a shower of metal. Health pickups should keep your tank rolling long enough for you to steamroll that valuable parade of strippers.

### Guardian Angel

Your buddy Angel wants to toughen you up, and this particular method is pulled straight out of *Talladega Nights*. It requires you to drive carefully around town as a tiger hangs out in the back seat. Bump into a lightpole or take a turn too sharp, and he'll start mauling you. If you're playing in co-op, your partner must assault the tiger to keep him out of your hair.

As opposed to the random nature of these activities in previous games, these hijinks are tied to the Syndicate war in *Saints Row: The Third*. "We want this cohesive experience where players walk away going 'I can't believe I'm seeing this. I can't believe I'm f---ing doing this,'" says senior producer Greg Donovan. Mayhem missions reward you for taking out Syndicate property, and the goofier ones like Insurance Fraud and Guardian Angel are billed as training exercises to strengthen your character so he can face the enemy without fear.



Cars will deform and crumple in a more realistic manner thanks to the new tech





## Nyteblayde

One of the most popular television characters in Steelport is Nyteblayde, a supernatural vampire hunter that becomes a vampire (and is subsequently hunted by his own organization). The show stirs up a media fervor à la *Twilight*, and the general public can't get enough of him. He's portrayed by Josh Birk, a narcissistic actor without an ounce of self awareness. This hack stretches his acting chops by taking a role in a movie based on the Saints, and embeds himself in the gang to study. A perpetual idiot, he's responsible for the gang going to jail in the first mission after accidentally setting off the silent alarm. You encounter him numerous times throughout the story, both in street clothes and in full Nyteblayde regalia. One mission even involves dressing up as Nyteblayde's arch-nemesis to lure the actor out of hiding.



## Never A Dull Moment

The first two Saints Row games crammed more activities per square foot than any other open-world game, and the third entry is no different. Driving just a few blocks gives you plenty of opportunities to start a story mission, customize your character, engage a flashpoint, surf on top of a car, or throw yourself into traffic for some good old-fashioned insurance fraud. Interactive darts and bowling minigames aren't nearly out-there enough for this series. The calling cards of this franchise are cartoonish action, a wicked sense of humor, and gratuitous violence.

"One of my favorite things I heard from a Saints Row 2 player was 'I was driving down the street with knee-cappers on my pickup truck, running over old grannies while my co-op partner skydived naked out of a plane and landed in the back of my pickup truck.' We want that s--- to happen all the time in Saints Row: The Third," Donovan says. With crazier weapons, more colorful gangs, and a new playground to contain it all, the game hardly has a shortage of mayhem.

Because of the series' outsized antics, many critics fail to mention the fantastic gameplay experience at its core. Gunplay feels great, vehicles are maneuverable and fun, diversions are sprinkled across virtually every block, combat encourages creativity, every mission objective feels fresh, and the action is relentless. One mission in Saints Row: The Third features an aerial battle that places you behind the controls of a falling tank, battling other airborne tanks as you both plummet toward the ground. Greg Donovan puts it best when he describes the Saints Row design mantra — "Embrace the crazy. Fun trumps all." ♦

Keep an eye on [gameinformer.com/saintsrow](http://gameinformer.com/saintsrow) throughout March for more Saints Row: The Third coverage

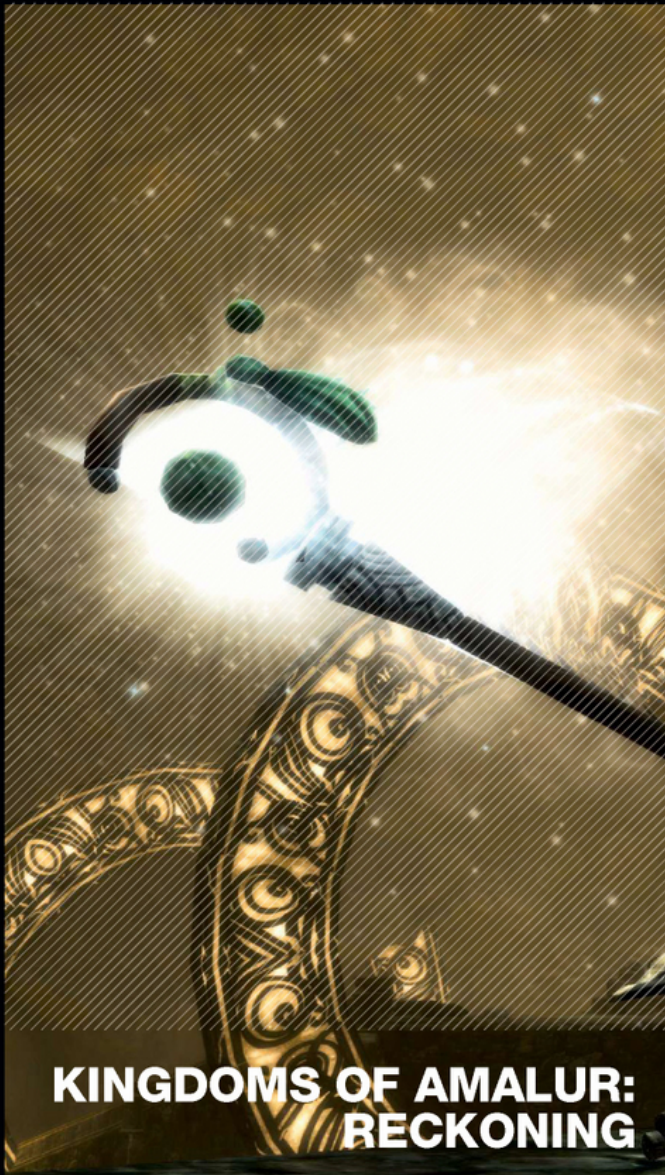

**KINGDOMS OF AMALUR:  
RECKONING**



» **Platform**

PlayStation 3  
Xbox 360 • PC

» **Style**

1-Player Role-Playing

» **Publisher**

Electronic Arts

» **Developer**

Big Huge Games/38 Studios

» **Release**

2012

## A FANTASY GAME DREAM TEAM CREATES THE NEXT GREAT RPG CONTENDER

**W**hen I first heard the story behind the development of *Kingdoms of Amalur: Reckoning*, I found it hard to believe. From the legendary talent involved to the way things have serendipitously fallen into place for a once-humble real-time strategy game developer, this tale perfectly fits the structure of an epic fantasy game in the same style as *Reckoning*. The story is real, though, and with help from Curt Schilling's 38 Studios and publishing partner EA, Big Huge Games could be the next name worth watching in the world of RPGs.

by Phil Kollar



Big Huge Games creative director Mark Nelson jokes that *Reckoning* has more impressive doors than any RPG to come before



## REBIRTH

When THQ purchased Big Huge Games in early 2008, the studio was in the midst of a huge transition. It had built its reputation with the *Rise of Nations* real-time strategy series for PC, but the studio had plans to expand into a new genre.

"We had a terrible challenge," recalls executive game creator Ken Rolston. "When I was brought on, they had been planning to shift from an RTS company to a role-playing game design company for about a year. They had people who were experienced in making RPGs but not in producing them. They wanted to make a pitch to THQ, so they brought me on."

Rolston used his experience working for Bethesda (see sidebar) to flesh out the world of the new project, which won them THQ funding. This, in turn, led to THQ purchasing the developer, but after two years of work, the publisher decided that it couldn't give the project as much money as it needed to succeed. Big Huge Games would be closed unless someone else offered to buy them from THQ.

With only days left until Big Huge Games was scheduled to lock its doors, 38 Studios acquired the developer and tasked it with working on a new RPG. Though the core concept and world created for the THQ project had to be abandoned, the team was allowed to keep the internal tools it had developed—dubbed the Big Huge Engine. This enabled the team to switch directions to *Reckoning* much faster. More importantly, Rolston says the experience with THQ trained the amateur RPG team in the difficulties of working in this new genre.

"The process of developing a role-playing game is the worst possible production challenge you can have," Rolston explains. "There are millions of different systems. They're all competing for the limelight. They're fighting for priority in assets and attention. It's just very hard to do....It was a very long and difficult process teaching them how to be an RPG developer. By the time we were acquired by 38 Studios, Big Huge had learned all the entry-level skills that we needed."

Rolston describes the new partnership with 38 Studios as "amazingly great dumb luck." Founded by baseball pitcher Curt Schilling in 2006, 38 is hard at work on its first entry into the competitive MMORPG market. To improve its chances at success, the studio wants to release a single-player RPG that introduces gamers to its universe. With a second lease on life for Big Huge Games, *Kingdoms of Amalur: Reckoning* was born.

## REVIVAL

Though Rolston and several other members of the team are best known for their work on the *Elder Scrolls* series, *Reckoning* begins with a plot device reminiscent of another classic RPG—*Planescape: Torment*. The protagonist—a male or female from one of four races—wakes up buried beneath a pile of corpses, struggling to his or her feet with the realization that he or she has been resurrected. The game's story revolves around discovering the main character's true identity.

The connection to *Planescape* is not coincidental. "A good game idea starts out with a good premise," Rolston says. "In fact, I had



just played Planescape, and that is actually the best starting premise I have ever seen in any game."

The idea of beginning Reckoning similarly first occurred to Rolston when he was presented with a timeline for the world of Amalur, a 10,000-year history crafted by beloved fantasy writer R.A. Salvatore, best known for his Forgotten Realms novels. Rolston and the team at Big Huge Games decided to set their title right in the middle of that timeline, during a period known as the Age of Arcana.

One of the unique aspects of the world of Amalur is a magical device known as the Well

of Souls – basically a method of explaining why players can die and respawn over and over in the upcoming Amalur MMO. This powerful machine is first created in the Age of Arcana, and the hero of Reckoning is the first person in the world to benefit from its regenerative powers.

"The Well of Souls gives us a premise for the character being totally involved in his or her personal mystery," Rolston points out. "That personal mystery is the mystery of the whole world." Rolston believes that tying together the character, world, and player is the key to creating a compelling video game narrative.

But unlike many RPGs, story is not the main attraction of Reckoning. What's most likely to grab the attention of gamers – what Big Huge Games is truly doing differently than most anyone else in the RPG field right now – is the combat. Lead combat designer Joe Quadara says that Reckoning's action has more in common with fighting games than other RPGs. "All the basic hardcore fighting game lingo applies to our game," he says.

"We've got frame advantage, different kinds of hit reacts, juggles, and combos. They're all valid and in there. They don't necessarily need to be used, but it's all there."

This focus on moment-to-moment combat is clear early in the demo. After waking up,

## INTRODUCING KEN ROLSTON

It's possible that you've never heard of him before, but if you love the Elder Scrolls series or RPGs in general, Ken Rolston is a name you should know. Reckoning creative director Mark Nelson describes Rolston as "the father of open-world RPG gaming," and he's got the history to back it up.

Rolston's game design career started in the '80s. Working at the time as an English teacher, he decided to take a chance and send some Dungeons & Dragons manuscripts in to publisher TSR. He quickly discovered that he "could not get anything rejected" and went on to work for various pen-and-paper projects, including Warhammer and Paranoia.

Rolston shifted into the world of video games in the '90s, but did not find immediate success. His first five projects were canceled, including an adventure game about dolphins in space titled Blue Star. "[The publisher] wanted a Star Trek thing where there's no conflict," Rolston explains. "It had not occurred to them that if they didn't have conflict, they were not going to be doing what computer games do particularly well."

After a layoff due to yet another cancellation, Rolston joined Bethesda. Unsurprisingly, his prowess with pen-and-paper RPGs impressed the company, particularly his work in the RuneQuest setting. "The lead designer at Bethesda loved RuneQuest," Rolston reminisces. "It essentially uses the Elder Scrolls system. You advance your character by using your skills."

Rolston finally found his footing at Bethesda and became the lead designer for Morrowind and Oblivion. Following Oblivion's completion, Rolston retired, only to be pulled into working for Big Huge Games four months later.

Though he's not yet sure what the future holds, Reckoning could be Rolston's final game, which is one of the reasons that he doesn't think he'll screw it up. "I want something that's new and worth having," Rolston says. "I wasn't going to come back and do another role-playing game unless it was better than anything I had done before. It's too much trouble, too many years out of my life, too many opportunities to fail to want to do that."



In addition to the main quest, Reckoning will feature faction quests and plenty of random dungeons to plunder



the character is ordered by a gnome to grab a sword from a nearby corpse. The character is soon approached by a group of faer gorta, Amalur's version of undead skeletal warriors.

The combat sequence that unfolds in this first encounter is fast and fluid. Characters can equip up to two weapons at once, with each assigned to a face button on the controller and a trigger devoted to the character's shield. That leaves a limited number of buttons to press, so combat in Reckoning is much more about timing and stance than memorizing long strings of combos.

For example, if you slash once with the sword, pause for a moment, then slash again, your character will launch the targeted enemy into the air. Move out of a block with your hammer, and your character will kick your opponent, putting distance between you and your foe.

You can switch between your two equipped weapons on the fly, and attacks are modified by other actions, such as whether you're moving from a run into an attack or whether you're attacking out of a dodge. Even with a relatively simple, three-button combat system, Big Huge Games has created depth.

Don't think that the fast-paced combat means that the RPG elements are completely lost, though. Creative director Mark Nelson says that Diablo-style loot collection is a major part of the game, alongside spending ability points and balancing stats. "This is really just a hardcore RPG at heart," he assures us. "It's got all those numbers, it's got all that backbone – all that crunchy stuff that RPG fans like."



## REINVENTION

Big Huge Games recognizes that its greatest challenge with Reckoning is standing out in a crowded RPG market. Its approach to this problem is creating a fantasy world informed by stereotypes of the genre but not a slave to them, beginning with its visuals. "We didn't want to be afraid of color," explains principal concept artist Sean Murray.

Mark Nelson says this idea was furthered by R.A. Salvatore's insistence on creating a world that is not entirely grim. "Players have to feel like they belong here and like this is a world worth defending," he says. "We always know that eventually you're going to end up saving the world. If you don't believe in that world, why bother trying to save it?"

With an exaggerated, cartoonish art style that's more comparable to World of Warcraft than Elder Scrolls, Reckoning also sets itself apart by offering unique twists on the monsters normally encountered in fantasy games. Each of Amalur's creatures has singular behaviors and tells for their large attacks that players must learn to survive.

For example, the large serpent creature showcased in the screen below – called a banshaen – looks and acts similarly to a medusa or the naga from Warcraft lore. She has several surprising moves, though, including one where she belches out a group

## THE AMALUR DREAM TEAM

While Elder Scrolls veteran Ken Rolston and his team at Big Huge Games are hard at work on Reckoning, the greater lore and look of the Amalur franchise is being shaped by a talented trio at 38 Studios. Here are the big names behind the creation of this new fantasy universe:

**Curt Schilling** – Former Major League Baseball pitcher Curt Schilling may not strike you as the most obvious choice for a game developer, but he's an avid MMO player and has been since the days of EverQuest. It's unclear how much Schilling is directly involved in the development process, but he founded 38 Studios.

**Todd McFarlane** – McFarlane is a visionary artist best known for founding Image Comics, creating Spawn, and starting his own high-end toy line. His visual style is informing the world of Reckoning. Big Huge Games concept artist Sean Murray says that McFarlane is constantly pushing the art team to try new and innovative things within the fantasy setting.

**R.A. Salvatore** – Salvatore has been writing hit fantasy and sci-fi novels since the '80s with enough success that he's had a whopping 22 books on the *New York Times* best-sellers list. As the creator of fan favorite Forgotten Realms hero Drizzt Do'Urden, you can expect him to bring a literary edge and depth to Reckoning's colorful fantasy.







of eggs that hatch smaller frog-like murghan. These minions cause trouble as you attempt to take out their source, stabbing you with tridents and performing a group attack where they summon lightning and shoot it like a turret. Advanced players will know to smash the eggs before the murghan hatch.

Another one of Salvatore's rules for Amalur? From gorgeous meadows to dilapidated ruins, everything must be there for a reason, including all of the approximately 120 dungeons in the game. "None of them are just an offshoot," promises world artist Jessica Hara. "They're all more or less fully fleshed out dungeons. There's something to explore or a quest involved."

Big Huge Games also wants to distance itself from the fantasy norm of sweeping, epic, but often generic soundtracks. "You can take the music from any of those games and shove it into another game, and it doesn't really matter," laments audio engineer Mark Cromer. Reckoning audio director Grant Kirkhope is an industry veteran best known for his energetic work on a bevy of Rare titles such as Goldeneye, Banjo-Kazooie, and Viva Piñata.

Kirkhope plans to set Reckoning apart by taking a lesson learned from legendary composer John Williams. "The term is leitmotif," Cromer explains. "It's an opera term that Wagner created. It's the concept of attaching

a melody or theme to a character, like every time you see Darth Vader." Older Japanese RPGs like Final Fantasy VI and Chrono Trigger were notorious for using leitmotifs to great effect, and though Reckoning's music is fully orchestrated, Kirkhope wants to revive that style of game soundtrack.

Part of the trick to keeping Reckoning's music interesting is that it does not play constantly. "Music is more effective when it goes away sometimes," Cromer says.

Rolston chimes in: "Without white space, everything is just noise."

Rolston isn't wrong about the "terrible challenge" that Big Huge Games is attempting to overcome. Even with big names like Spawn creator Todd McFarlane and R.A. Salvatore backing it up, the developer needs to prove that it can make a giant, open-world RPG while at the same time making more complex, fast-paced combat work in this type of game.

So can they pull it off? As I watch the demo a second time and witness a rogue cut through a group of kobolds in a way that looks stylish and satisfying, I can't help but feel a pang of disappointment at thinking about how real-time combat works in other RPGs. If Big Huge Games succeeds in this gamble, the Fables, Dragon Ages, and yes, even Elder Scrolls of the world may have some stiff competition. ♦

## AN RPG WITHOUT CLASS

Like the Elder Scrolls series that it has drawn so much talent from, Reckoning does not use a strict class-based system to lock players into a certain play style from the beginning. Instead, players can assign multiple ability points per level to one of three primary trees: might, sorcery, and finesse. As they progress in each tree, players unlock destinies — essentially class titles that confer bonuses for sticking to a certain path or mixing and matching in interesting ways.

In addition to mixing up the progression path, Big Huge challenges itself to make the mage and rogue classes as fun to take into battle as warriors. For magic users, this means introducing a brand new weapon type called chakram, circular blades that are probably best known for their use on *Xena: Warrior Princess*.

Reckoning's version of chakram allow for some awe-inspiring combos, including moves that shove enemies away and send the mage flying back, creating distance that allows them to sling spells. Get far enough away from enemies, and you can unleash a room-clearing spell like meteor. If you prefer to stay close, you can tag enemies with mark of flame, a damage-over-time fire spell that can be detonated, exploding multiple baddies at a time of your choosing.

The rogue character I saw looked more like a ninja than a traditional fantasy rogue. Creative director Mark Nelson said his goal with the class was to make daggers — a normally wimpy weapon type — more fun than they've been in any previous RPG. If you time dagger combos perfectly, the weapon will glow, allowing for a guaranteed critical hit.

Rogues also have access to some powerful abilities, such as smoke bomb, which stuns enemies and puts you into stealth. Once in stealth mode, you can sneak up on unsuspecting enemies and launch into instant-kill attacks.

The key to Reckoning's destiny system is keeping it flexible for players of all types. "We want the game to respond to how you're playing instead of forcing you to make a choice," Nelson says.



## L.A. Noire

Hands-on with Rockstar's detective epic

Since we gave the world its first look into the dark world of L.A. Noire with our March 2010 cover story, Rockstar has incrementally lifted the veil, each time revealing a bit more about this intriguing title. Recently, I got my first opportunity to play L.A. Noire.

Rockstar ran me through a brief interlude that showed protagonist Cole Phelps arriving at his new job at the detective desk of the LAPD (and a small sampling of a case entitled "The Red Lipstick Killer"). Phelps is introduced as the

replacement to retiring detective Floyd Rose (who seems to be "retiring" under shady circumstances), and placed with Rose's old partner, Rusty Galloway. Throughout our session, it's clear that Galloway is not pleased to be paired with this hotter-than-thou rookie.

After this introduction, I took the controller and began a new case, "The Silk Stocking Murder." Like many of the recent trailers for the game, this case is tied to Los Angeles' real-life Black Dahlia murders. We're called into action by Captain

Donnelly. A Hispanic woman has been found dead near city hall. The M.O. appears to be that of the Black Dahlia killer – or a copycat.

As we arrive, we're met by some sleazy reporters. "Another tramp, another message," says one. "Is the Werewolf back in business?" ("The Werewolf" is another period nickname for the Black Dahlia killer.) Phelps is not amused, rebuffing the wags by asking them if they have a mother or sister.

The crime scene is gruesome. The woman is naked and mutilated. Inspecting her body, I see that a ring has been removed from her finger, and cryptic messages – "B.D." and "Kiss the Blood" – have been scrawled on her torso.

I begin investigating the crime scene, which is one of the game's main play mechanics. Generally, you proceed just as you would in real life – something catches your eye, you bend down and pick it up. You can rotate items in your hand with the thumbstick, searching for a "sweet spot" that will initiate rumble and reveal a further clue in the item. For example, you might pick up an envelope and read the address on it, then open it up and check the contents inside. It works well, and if you get off track, your partner is there to spot things you miss. It's important to scour the location for every clue, as missing things limits your options in subsequent interrogations. This particular crime scene is strange; we're clearly being led on a path of blood stains to find objects like a library card, a ring, and other personal effects. This path takes us to a roof of a nearby building where we finally discern the identity and address of the victim: Ms. Antonia Maldonado.





From here, we head into investigation and interrogation. From Ms. Maldonado's landlord to her estranged husband, we track down each person of interest in the case, asking questions based on the evidence we acquired in our searches of her residence and the crime scene. I've always felt that *L.A. Noire's* success will ride on its ability to make these interrogations feel real and compelling. You must pay attention to each character's facial reactions – you can't afford to be glib, but pressing a witness too hard makes them shut down entirely.

If you accuse someone of lying, you better have a clue to back up your claim. This is made easy by your in-game notebook, which takes automatic notes of every relevant clue, address, person of interest, and fact. If the witness rebuffs your accusation, you simply have to select the clue that proves them wrong and call them on it. Usually, they'll give up the crucial information that takes you to your next destination. The

conversation mechanics are simple and effective. Three simple button presses (indicating whether you believe them, are skeptical of their answer, or think they are outright lying to you) dictate your response. Overall, it's similar to the system seen in *Mass Effect*, giving you a good sense of your reply without resorting to verbatim dialogue options.

The trail of the case takes many twists and turns – recently filed divorce papers seem to finger her husband, who has a flimsy alibi for the night she was murdered. However, further interrogation reveals that he's not the culprit. A lead that first appeared to go nowhere – her late night visit to a green grocer to call for a cab following a night of drinking – suddenly takes a turn when I uncover a bloody scalpel in the grocer's back room. After a quick car chase (which felt similar to the driving in *GTA*, making adjustments for the boaty physics of the period cars),

we apprehend the grocer.

However, I got the sense that this was not the full story. Our captain seemed eager to wrap up the case, deliver the suspect to the district attorney, and write it off as a copycat murder. If it was that simple, why the elaborate trail of clues at the crime scene and the messages scrawled on her body? Is the Black Dahlia killer still stalking the women of L.A.? Sadly, I didn't get a chance to allay these suspicions in my brief hands-on session. I have a hunch that the answers to these questions will play heavily into the larger story being told in *L.A. Noire* – one that is likely tied to the apparent corruption at the LAPD's highest levels. However, there is one thing I'm increasingly sure of – *L.A. Noire* is going to give gamers an experience unlike anything we've ever played before. Conversation trumps gunplay, and the real truth is buried under layers of subterfuge. I can't wait. — **Matt Helgeson**

- » **Platform**  
PlayStation 3  
Xbox 360
- » **Style**  
1-Player Action/  
Adventure
- » **Publisher**  
Rockstar Games
- » **Developer**  
Team Bondi
- » **Release**  
May 17



Like the films that inspired it, *L.A. Noire* features dramatic cinematography

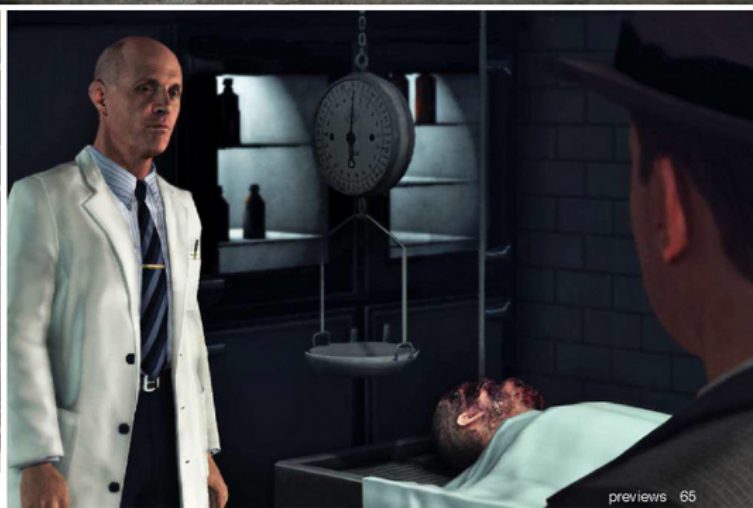



# Rage

Variety is the spice of life in id's potent wasteland

» **Platform**  
PlayStation 3  
Xbox 360 • PC • Mac

» **Style**  
1-Player Shooter  
(Online TBA)

» **Publisher**  
Bethesda

» **Developer**  
id Software

» **Release**  
September 13

In the six and a half years since id Software released *Doom 3*, the industry has had no shortage of genre-redefining first-person shooters. *Fallout 3* delivered one of the deepest role-playing experiences players have seen yet, *Borderlands* features a gun count numbering in the millions, and *Left 4 Dead* revolutionized co-op gameplay. What can *Rage* offer players who are already veterans of these post-apocalyptic wastelands? After getting some hands-on time with the game the answer became clear: a little bit of everything. We've broken down five different areas that separate *Rage* from the rest of the shooters.

## Open and Closed

Id describes *Rage* as an open-world FPS, but *Rage*'s world is defined as much by what's missing from it as what's included. The developer is taking a decidedly linear approach to creating an open-world game. That may sound like a disappointing contradiction, but you likely won't miss what the developer is cutting out: You won't find huge barren expanses that only exist to sell a sense of scale, and you won't tread through the same cookie cutter buildings that have been copied and pasted a dozen times over the landscape. Instead, each area serves a purpose and features unique geometry and textures. The larger wasteland connects gaming hubs, but

they are tightly packed together so you won't spend a lot of time traveling between action set pieces. The areas inhabited by enemies are further broken down into the kind of smartly designed levels for which id is known.

During our demo, we explored a city built out of a dilapidated subway station, blew up an enemy faction's explosives caches in the bowels of a dam facility, and glimpsed the mutant-infested streets of Dead City. Although the areas we saw shared a similar color palette (don't expect a lot of bright primary colors if you survive the apocalypse), id succeeds in making each location feel distinct thanks in part to unique NPCs and a healthy variety in enemy types. Each character we talked to in town had a unique name and character model, similar to *Fallout*. Id tells us the story is similarly concise: While you can travel to any area in the wasteland whenever you want, you are never without a clear objective pointing you to your next location.

## Lock and Load

No first-person shooter is complete without a satisfying arsenal, and as the creators of the FPS genre, the developers at id know what they're doing. Instead of giving players millions of guns to sift through like *Borderlands*, id is handcrafting each weapon to be indispensable to gameplay. The weapons we tried out are standard fare for a shooter – a pistol, shotgun, assault rifle, etc. – but different ammo types and a clever two-wheel quick select mechanic for changing loadouts drastically opened up the gunplay. After a few minutes of action, we were easily switching up our gun and ammo selection on an enemy-by-enemy basis.

While each gun packed a satisfying punch, we were more intrigued by *Rage*'s Quick Use items. At any time, players can equip a Quick Use item to the left shoulder button. Some of these items are traditional offerings, like grenades or health packs, but others inject variety into firefights. We tried out several deadly contraptions, including wingstick boomerangs that slice the limbs off of your foes before returning to you,

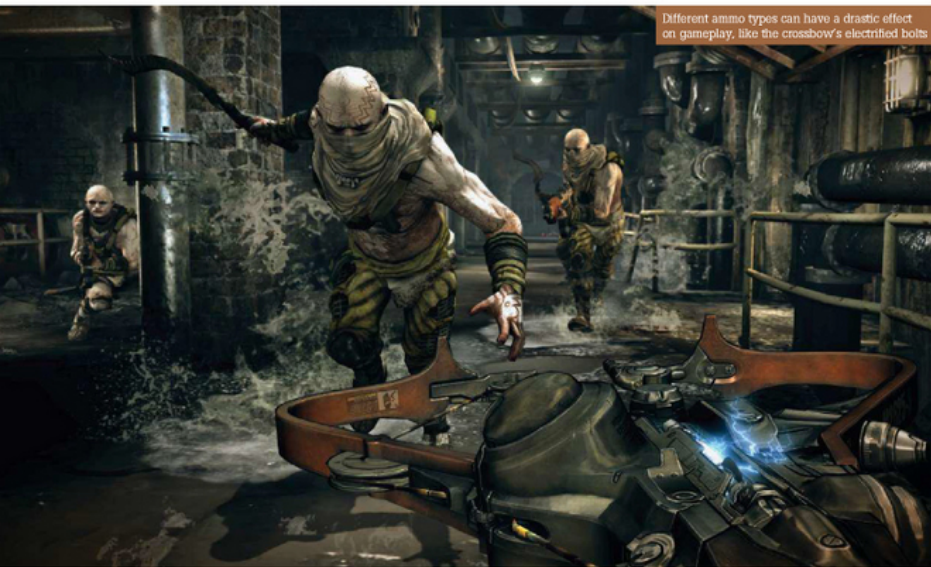

an autonomous spider turret that seeks out and engages enemies (allowing you plenty of flanking opportunities), and RC cars strapped with C4. Incorporating these deadly gadgets into the gunplay was effortless.

#### DIY Items

All of the Quick Use Items mentioned above can be built by the player using Rage's crafting mechanic. As you make your way through the wasteland, you'll find blueprints for new items that you can craft at any time. Lead designer Matt Hooper tells us there are at least a dozen blueprints for players to find, but, like your arsenal, id wants to make sure none of the Quick Use items feel superfluous. After finding a blueprint, players can build the new toy out of components they gather by looting bodies and other objects found within the environment. This provides a concrete reason to thoroughly explore each area. If you're too lazy to scavenge for parts, Rage also features a full-fledged economy, allowing you to buy pre-built items from merchants. Certain Quick Use items and weapons can also be upgraded. For example, the wing-stick's attacking power can be improved, allowing it to decapitate more than one enemy in a single throw.

#### Road Rage

Perhaps the biggest departure from id's standard gameplay formula is the incorporation of vehicles. Plenty of shooters offer isolated driving segments in their campaigns, but more often than not they feel like half-baked attempts to change up gameplay. id has made it a priority to get Rage's vehicles right, and both the ATV and dune buggy felt responsive thanks to a traditional racing control scheme (don't expect to steer via a reticle like Halo). Rage sports three unique classes of vehicles, each of which offers multiple upgrades to make them faster, stronger, and deadlier. After getting a feel for a souped-up dune buggy, we tried our hand at a few races on a desert canyon track. The combat race was by far our favorite event, even though it created a stark break from the game's tone; turbo boosts, force shields, and power-ups made the race feel more like Mario Kart than an id game—until we reduced our rival into a flaming pile of twisted steel.

#### Diversity Is King

If there's one thing we learned from our hands-on demo, it's that id is willing to add anything



Outdoor environments give players much-needed room to maneuver

to Rage's formula if it makes the game more fun. Although Rage's story may be linear, we saw plenty of distractions to keep players entertained. After trying out a few races, we blasted our fill of deformed monsters in Rage's Mutant Bash TV reality show, then picked up some extra cash by completing a dynamic secondary mission that had us running enemy dune buggies off of the wasteland's dusty roads. Players can also partake in a variety of minigames with locals in the human cities.

id assures us that none of these diversions interfere with the bread-and-butter gunplay. Not only was the action satisfyingly visceral and locked in at a fluid 60 frames per second, it also convinced us that the famed developer is more than capable of competing with modern shooters. The final segment of the demo culminated in

a fight against a God of War-sized boss mutant, who ripped chunks of concrete off of a nearby building and hurled them at the player as he frantically shot rockets back at the monster's face. The fight felt all the more epic thanks to the fact that it didn't have to rely on quick time events to sell the action.

Rage's multiplayer is still a mystery, although id co-founder and technical director John Carmack told us that development has taken roughly two years longer than they expected, in part due to extra time spent making the online component more fun. We'll have to wait a bit longer to see what multiplayer entails, but if id's pedigree is anything to go by, playing with friends should be at least as entertaining as heading into the wasteland by yourself. — **Jeff Marchiafava**



Dynamic slow motion shots make races even more cinematic



# Duke Nukem Forever

Duke delivers a shotgun blast of nostalgia

» **Platform**  
PlayStation 3  
Xbox 360 • PC

» **Style**  
1-Player Shooter

» **Publisher**  
2K Games

» **Developer**  
Gearbox/Triptych  
Games/3D Realms

» **Release**  
May 3

After 14 years of development purgatory, a presumed death, and his subsequent resurrection thanks to Gearbox Software's Randy Pitchford, Duke Nukem is ready to return to the spotlight. To see how the action hero has changed since his last ass-kicking escapade, we blasted our way through the first 90 minutes of the game.

Duke Nukem Forever begins with a familiar scenario that transports me immediately back to 1996—the action hero parked in front of a urinal unleashing his preternatural stream. Duke and a group of EDF soldiers are gathered in a stadium locker room with the commander in front of a dry erase board explaining the tactics for Operation C—Block, the plan for preventing the aliens from taking our ladies. When you have Duke on your side, the only plan you need is ammo. Moving through the stadium tunnels and onto the gridiron, I come face to face with a giant Cycloid

at midfield. A classic Duke Nukem boss battle ensues, and after taking down the massive alien, Duke kicks its cyclops eye through the uprights in celebration of his victory. All hail the king, baby.

The camera pans out from the football field, through a flat-screen television, and into a luxurious penthouse apartment on top of the Lady Killer casino in Las Vegas. Duke's holding a game controller while being pleased by the Holmsom Kids, two *Lolita*-locking pop stars whose parents obviously taught them the value of sharing. Opulence: Duke has it. The young ladies ask Duke if he thinks the video game is any good, to which he curtly replies, "Yeah, but after 12 f---ing years, it should be."

Dropping the game controller and grabbing the remote, Duke flips through channels and stumbles upon a commercial for the *Damn, It's Late Show*. Tonight's guest? The one and only Duke Nukem. Before heading down to the studio on a

lower level of the casino, I peruse Duke's impressive digs. With marble pillars, a wading pool, and vaulted ceilings in his living room, he's a perfect candidate for *MTV Cribs*. Walking into the lavish bathroom, I stare into the mirror and press the activate button. "You want to touch it, don't you," Duke egomaniacally growls. These classic Duke moments aren't just there for laughs; the first time you perform ego boosting actions like admiring his physique in the mirror or lifting an absurd amount of weights, Duke's maximum ego bar, which acts as a health meter, increases.

I make my way through Duke's gilded halls and down to the television studio, stopping in the green room just in time to catch a breaking news report. The aliens have returned to Earth, but the President is currently campaigning for peaceful talks aimed at strengthening ties. As I make my way backstage, a young fan approaches Duke asking for an autograph. I take

the copy of *Why I'm So Great - Duke In His Own Words* and a pen - it's up to me to fulfill the lad's dreams. Rather than try to master the clunky Etch-A-Sketch style controls well enough to write something legible, I draw a crude hand with an extended middle finger and give the book back to the kid.

Unfortunately, the show won't go on. When I walk out to the empty set, the host explains the Duke chat has been canceled so the network can focus on covering the latest alien outbreak. Duke heads to the Duke Cave to assess the situation. During a video conference, the president and an army general both urge Duke to avoid retaliation. The president wants to give peace a chance, and has a meeting scheduled with the alien's high leader.

When Duke leaves his war room, he knows it's already too late for diplomacy. Aliens have invaded his casino, drunk his beer, and kidnaped the hot chicks. During the following sequences I restore power to the casino, mount an oversized turret to take down an alien mothership while fending off incoming starcraft, and light up any invader who foolishly gets in my way as I move through the casino halls. All the while, Duke slings his signature one-liners with the bravado of Arnold Schwarzenegger, Bruce Willis, and Bruce Campbell combined. With no cover mechanics, limited AI, and random enemy spawns, the gunfights are classic Duke Nukem, but Gearbox balances these dated encounters with a series of environmental puzzles and a sequence that finds a shrunken Duke racing through the casino in an RC car.

If the fights get out of hand, Duke has a few boosts at his disposal to turn the tables. When



A few pigs drop in for a roast

Duke pops steroid pills, he trades firearms in favor of his god-given guns, dropping enemies with one punch. If you're feeling overwhelmed by gunfire and taking too much damage, Duke can channel his inner Frank the Tank by cracking open a beer to give himself increased damage resistance to damage. The bolstered defense comes at a cost; apparently Duke's lightweight, and pounding just one cold one gives him beer goggles. The blurred vision makes it tough to line up shots.

Once he's flushed the aliens from his casino, Duke runs into the general and some EDF forces on the Vegas strip. The general breaks down the situation - the aliens have commandeered the Hoover Dam and harnessed its generators to create a wormhole. Destroying the wormhole is obviously a primary objective, but Duke has other priorities, quipping, "Screw the dam, where are they taking our chicks?"

The demo concludes with Duke fighting through the Vegas streets until he encounters

a towering Battlelord. This boss battle plays out similarly to the first one, with Duke strafing around oncoming missiles while returning fire and collecting more ammo. When he finally gets the best of the beast, Duke humiliates it by using its family jewels as a speedbag.

As a fan who grew up with the series, playing Duke Nukem Forever feels like stepping into a time travel machine and returning to an era where *Beavis & Butt-head* was the most popular show in school and Tupac dominated the radio waves. Shooters have progressed a long way in 14 years, but Duke Nukem Forever stubbornly clings to aged design tenets for better and for worse. Though some may find the sophomoric humor, arena style boss battles, random enemy spawning, and environmental puzzles frustratingly dated, jumping back into Duke's oversized boots feels like uncovering a lost game in an archaeological dig. It's a missing piece of video gaming history that's been the butt of so many jokes and the focus of so much speculation that many may check the game out due to morbid curiosity. If Gearbox can sharpen up the noticeably dated graphics, cure the occasional hitching, and alter the pace with non-shooting sequences that keep the action from becoming monotonous, it could turn out better than anyone expected given the marathon development cycle that spanned multiple console generations. » **Matt Bertz**



Good, bad - Duke's the guy with the gun





# Infamous 2

What goes around comes around

» **Platform**  
PlayStation 3

» **Style**  
1-Player Action

» **Publisher**  
Sony Computer  
Entertainment

» **Developer**  
Sucker Punch  
Productions

» **Release**  
June 7

**B**lasting thugs with lightning bolts was a major aspect of the original *Infamous*, but underneath all of the electrical mayhem was the story of Cole MacGrath and how he chose to use his extraordinary powers. Players determined how Cole affected Empire City and its inhabitants, and the concept of karma is returning for *Infamous 2* with some notable improvements.

When video games implement moral choices, your actions are typically classified as good or evil. Developer Sucker Punch Productions is hoping to veer away from that tradition in *Infamous 2*. "I don't want to pass too much judgment on players," says producer Brian Fleming. "I think of it more as chaos and order. A more surgical and a more chaotic approach rather than good and evil."

Representing the extremes on the karma scale are two super-powered allies Cole encounters in the new city of New Marais. On the orderly side is a woman named Kuo who controls ice,

while Nix is the chaotic one who manipulates fire. These two ladies suggest different approaches to various situations, and it's up to Cole to choose one. Unsurprisingly, Kuo's suggestions are more careful and precise, while Nix emphasizes death and destruction.

Nix and Kuo aren't just voices Cole hears over the radio; they pitch their ideas to you in person. When you choose one, the other knows her plan got rejected. In that way, your choices are tied to building relationships with the two companions. "A lot of the karma decisions are really made when you're choosing between people and approaches rather than mechanical things like 'Should I do A or B?'" Fleming says. "It's more along the lines of two people with their own approach to a problem."

Once you side with Nix or Kuo, they won't just sit back and watch you do all of the work. In many cases, they will accompany you on the mission, using their own super powers to help execute their plan. During these sequences, Cole

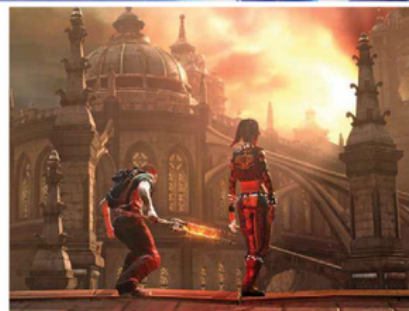

and his ally can combine certain powers to wear down the opposition. For instance, Kuo can create a fog of suspended ice particles around a group of militia, and when Cole charges the cloud with a lightning bolt, all of the soldiers inside are frozen solid.

If you find yourself coveting the ice- and fire-based powers of your companions, you'll be happy to learn that one of the major karma choices you'll make in *Infamous 2* involves obtaining a new suite of abilities for Cole. He's still an electricity-based hero, but after retrieving a piece of experimental technology called the transfer device, Cole can absorb a portion of Nix or Kuo's power, adding a handful of new (and upgradeable) abilities to your arsenal. This explains the mysterious ice-related tease at the end of the trailer shown at last year's E3.

One conspicuous outstanding question about karma is whether *Infamous 2* incorporates any decisions players made in the first game. Sony and Sucker Punch aren't revealing how (or if) that's going to happen, but even if it doesn't, we're excited to hear what other surprises the game has in store. "The whole philosophy for the game is to always be making everything better," Fleming says. "Karma is a big part of the game, so that's an area where—even if we liked what it was—we always have to be looking for ways to make it better." » **Joe Juba**

## Get Out of the Way!

Players who stuck to the good side of the spectrum in the first *Infamous* undoubtedly took a hit to their spotless reputations by accidentally smacking a pedestrian or two. Even if you were careful, sometimes they'd just wander into the fray. That shouldn't be a problem with *Infamous 2*, but you still want to be careful. "We've certainly spent a lot of time trying to get them to not run through the center of combat so you don't accidentally hurt people," says producer Brian Fleming. "But you can fire warning shots in the game now before you get into combat, and people will scatter. You've got to decide if that's the way you want to play."

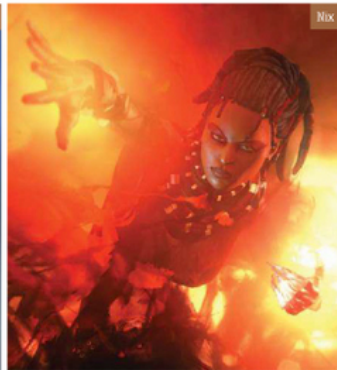



# The Last Guardian

New gameplay details emerge for Team Ico's colossal team-up

With a pedigree of heavy hitters like Ico and Shadow of the Colossus, expectations don't get loftier than those for The Last Guardian, the latest art house adventure from Team Ico. This month, I saw the first live play session demoed by legendary designer Fumito Ueda. While I can't speak to the overall experience of the game, I can already see elements that should please fans of Team Ico's PS2-era releases.

Outside of some visual similarities, the biggest thread that The Last Guardian shares with the previous games is the theme of partnership. Ueda explains that he becomes attached to AI characters and wants to continue exploring new ways of interacting with them in his games.

The Last Guardian offers surprising methods of working together with Trico, the giant cat-bird hybrid that serves as the protagonist's partner. Unlike Ico's Yorda or Agro, the horse from Shadow of the Colossus, Trico is the member of the duo with power. The unnamed main character relies on the creature constantly, whether to seek protection from heavily armored enemies stalking the desolate ruins, or as a makeshift ladder to reach higher levels of the environment.

Ueda says he wants the player's relationship with Trico to feel like the bond you would form with a pet. In other words, Trico doesn't always follow your orders. Often the boy needs to hunt down vases full of a mysterious liquid that Trico adores. In one early area, the boy tosses a vase onto a balcony he needs to access. Trico pulls itself up by its front paws to investigate the item, at which point the boy can climb up its feathers in a manner that looks very similar to how Wander scaled giants in Shadow of the Colossus.

At another point later in the demo, the boy needs Trico to join him on a small ledge. He calls over and over again, but like a haughty feline, the creature simply ignores him. "It seems like he's in a bad mood today," Ueda jokes. After a few more shouts, the beast finally leaps up and perches next to the boy on the ledge.

The occasional lack of cooperation is intentional, and the team wants Trico to feel like a real, living creature with a will of its own rather than the traditional "useful sidekick" that mindlessly follows orders. Ueda acknowledges that they need to walk a fine line by making the creature realistically follow its own whims without frustrat-



ing the player. As the game progresses, Ueda says the bond between Trico and the boy grows naturally, and this will be reflected in how well the creature follows orders.

In another portion of the demo, the boy separates from Trico to explore a passageway too tiny for the creature to squeeze through. On the other side, he discovers a guard, revealing another key element of The Last Guardian: The main character has no means of fighting.

The boy attempts to sneak past the lumbering guard, a shadowy creature reminiscent of the adversaries in Ico. The one advantage the boy has is agility; since the guard is decked out in bulky armor, the boy outruns him, clambering up a wall and out of the bad guy's reach. The boy may discover a weapon later in the game, but for the beginning, at least, he must rely on stealth and his feathery friend to do the fighting.

After witnessing the first 15 minutes of The Last Guardian, I still have plenty of burning questions. Team Ico's games are known for their sparse stories, but Ueda and company still haven't revealed even the most minor of details, such as who the boy is and how he met Trico. An unidentified narrator provides voiceover in Team Ico's traditional made-up language throughout the course of the game, but Ueda says this will be used more for guiding players rather than storytelling.

Whatever the origins of this surprising duo, The Last Guardian is shaping up to be an intriguing tale of friendship. Team Ico has mixed the platforming and environmental puzzle-solving of Ico with the majestic creature-climbing of Shadow of the Colossus while adding in some new mechanics to help set the formula apart. All that's left is to play the game for ourselves. **Phil Kollar**

- » **Platform**  
PlayStation 3
- » **Style**  
1-Player Action/Adventure
- » **Publisher**  
Sony Computer Entertainment
- » **Developer**  
Team Ico
- » **Release**  
2011



# Anarchy Reigns

Platinum brings brawlers into the online competitive realm

» **Platform**  
PlayStation 3  
Xbox 360

» **Style**  
1-Player Action  
(Multiplayer TBA)

» **Publisher**  
Sega

» **Developer**  
Platinum Games

» **Release**  
Fall

Sega and Platinum Games signed a four game deal in 2008 that resulted in Madworld, Infinite Space, Bayonetta, and Vanquish. Things went so well the companies are teaming up once again for new property Anarchy Reigns. Not everything about the game is brand new, however. Jack, the protagonist from Madworld, returns with his trademark Gator Tooth double chainsaw to hack challengers to bits. This time, it's in full color.

So why not call this Madworld 2? "There are characters that appeared in Madworld who will reappear in Anarchy Reigns," says producer Atsushi Inaba. "However, the story is not connected to Madworld." Inaba also says the gameplay is very different. "Madworld was a single player, third-person action game, whereas Anarchy Reigns is more of an online-focused multiplayer brawler," he clarifies.

Early trailers show named characters bashing the hell out of each other on city streets. Outside of Jack, Platinum has revealed a techno ninja called Zero (think Raiden from Metal Gear Solid 4), a blonde woman in a skintight nanosuit named Sasha, and a huge "cybrid" robotic bull man with the brain of a 31-year-old called Big Bull. This colorful cast of characters seems like the perfect place to reintroduce one of Platinum's



Sasha shows off her, uh, snow spikes

more popular characters, Bayonetta. Will she make a surprise appearance? "Unfortunately, I cannot answer that at this point. Sorry," Inaba apologizes. So you're saying there's a chance!

These characters duke it out with each other in what is described as the brawler equivalent of an

online multiplayer shooter. Inaba won't give us an exact number of players for multiplayer matches, but he promises more than four at once. Outside of standard deathmatches, confirmed modes include tag team and battle royal.

Anarchy Reigns is Platinum Games' first online multiplayer title, but it isn't solely focused on the competitive side. "We will definitely be including a story-based campaign mode," Inaba confirms. "Unlike the online battles, it will be something more serious for players to enjoy." Platinum didn't reveal whether you can tackle the campaign with every character, or if only a few have stories.

Details are vague at this point, but we're excited to find out more on Anarchy Reigns. Stay tuned for more updates over the coming months. » **Bryan Vore**

## Meet the Contestants

### Jack

Cybrid  
42  
Gator Tooth: Retractable double chainsaw attached to right arm.

### Zero

Human  
26  
Orimaru & Juzumaru: A pair of authentic Japanese katanas rumored to be part of the "Tenka Goken" blades of myth.

### Sasha

Human (Wears special nanomachine-equipped suit fitted with long range weaponry)  
24

Snow Spikes: Six long-range spikes are deployed from the back-mounted main unit and instantly form ice-coated blades.

### Big Bull

Cybrid (Brain is only remaining organic tissue)  
4 (Years since brain transfer. Biological age at transfer: 31)  
Jet Hammer: By releasing the safety locks restraining the Bull suit's propulsion system, the engine becomes a giant hammer.



Jack and his Gator Tooth return

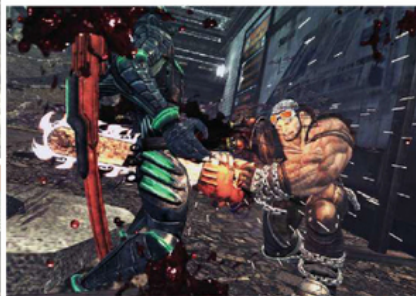



Cunning enemies like wraiths are less susceptible to tricky tactics

#### Owned!

A giant crab-like monster attacked Geralt at one point in the demo. This powerful enemy tore the poor witcher to shreds as he hacked ineffectually at its thick armor. CD Projekt has no problem putting creatures in the world that players likely aren't strong enough to defeat the first time they encounter them. On the plus side, nothing says you can't run away and fight it later after leveling up a bit – or perhaps getting clued into its weaknesses by asking around.

# The Witcher 2: Assassins of Kings

Hands-on with the new witching paradigm

Polish developer CD Projekt RED proved its ability to create complex, engaging, non-linear RPG worlds with 2007's *The Witcher*. The new combat system, which replaces the original's cumbersome quick time event-like battles, is *The Witcher 2*'s largest outstanding question mark. I jumped at the chance to play a small section of the game and see how it's coming along.

After taking a request from the local townstolk to look into a string of disappearances, I get a tip to investigate an old crypt a short walk beyond the walls. On my way through the countryside, a group of soldiers waylays me. With a minimum of fuss, I light one on fire with a magical sign, incapacitate the group with an alchemical flash-bomb, and disembowel one of them with a gory finishing move while he's reeling from the blast. With several foes still standing, though, things get dicier.

You can block, dodge, and string together quick and heavy attacks in *The Witcher 2*, but Geralt is no Kratos. The combat calls for a more strategic approach. Every action has a non-trivial animation to it, including being hit. It's easy to get interrupted trying to fling spells or grenades in the middle of a melee. By the same token, keeping

foes staggered is relatively simple if you have the luxury of focusing on them. In a one-on-many encounter like this, avoiding being swarmed is critical. I muddled my way through it by using rolling dodges to escape encircling enemies, but it was an inelegant solution – I picked up more than a few cuts and bruises as my attackers had no qualms about striking me in the middle of my frantic dodges.

Making my way to the crypt, I'm ambushed by wraiths coalescing out of the darkness. These intelligent foes declined to step in the magical traps I tried baiting them into, so Geralt's dazzling swordplay carried me through the battles. One minor issue arose during the exchanges with the wraiths, though: controlling Geralt's momentum during multi-target encounters can be tricky on a keyboard. Every time you want to change direction – say, to switch targets to an enemy winding up a big attack on your flank – Geralt realistically plants his foot and pauses before turning. This caused a fair amount of cursing, as I'm used to heroes in everything from *Devil May Cry* to *World of Warcraft* turning on a dime and executing commands the instant they are given. *The Witcher 2*'s combat is more deliberate, and the momentum issue is one more reason to think a step or two ahead and act accordingly. It does make it difficult to improvise on the fly, at least for my inexperienced fingers.

My investigations eventually lead me to the conclusion that a succubus is involved. After enlisting the reluctant aid of Geralt's friend Dandelion the bard, I head to its lair to draw it out. Taking control of Dandelion as he strums a lute and recites a poem declaring his devotion to demonic beauty, I'm faced with a choice when the jubbly creature appears: alert Geralt, who is waiting out of sight for a chance to confront the

goat-legged yet emphatically feminine demon, or follow her into her underground boudoir to explore unearthly pleasures.

"F---ing idiot actually went in," spits Geralt in disgust.

Back in control of the witcher, I determine that the succubus isn't the killer I'm looking for even if she has been (ahem) plying her trade in the area for some time. The demo ends with an oblivious Dandelion lying in her bed as Geralt makes his way back to town to continue the search.

The scenario I played was roughly an hour long, and comprises one half of one side quest. The fair-sized town it takes place in and around won't appear in all playthroughs of the game; the decisions you make earlier may not lead you there. The scale of non-linearity that this suggests is a bigger draw than the combat rework, the pretty graphics, or anything else. » **Adam Blessemer**

» **Platform**  
PC

» **Style**  
1-Player Role-Playing

» **Publisher**  
CD Projekt/Atari

» **Developer**  
CD Projekt RED

» **Release**

May 17

Even the weakest creature is a threat in sufficient numbers



# El Shaddai: Ascension of the Metatron

Hellish opponents, divine combat, and a little bit of platforming

» **Platform**  
PlayStation 3  
Xbox 360

» **Style**  
1-Player Action

» **Publisher**  
Ignition Entertainment

» **Developer**  
Ignition Entertainment

» **Release**  
Fall

I've been fascinated by the quirky, tongue-in-cheek style of *El Shaddai: Ascension of the Metatron* ever since its colorful debut at E3 2010. This month I had my first chance to play the game. After working through four chapters of the Biblical action game, I can confirm that this cult-hit-in-the-making is worth your attention.

After a brief outscene introducing heavenly scribe Enoch and his quest giver, the angel Lucifel, I took control of Enoch and began learning the basics of combat on "the Hand of Michael," a giant stone palm with seven fingers extending from it. Those digits will serve as prisons for seven angels that have rebelled against God. Enoch and Lucifel must hunt down the rogue group one by one.

Though some of its developers worked on the *Devil May Cry* games, combat in *El Shaddai* has a unique feel. Rather than focusing on the order that you string together button presses, Enoch's moves depend on timing. Repeatedly tap the attack button and he performs a series of quick slashes with his default weapon, the arch, a curved blade used like a traditional sword. Pause for a beat between attacks and flick the analog stick up, and Enoch launches enemies into the air. It takes getting used to, but when I found the combat flow, it almost felt musical. Adding in a Guitar Hero-style note scratch when you blow a combo wouldn't feel out of place.



In addition to the arch, Enoch gains access to a projectile called the gale and heavy gauntlets known as the veil. Enoch can only carry one weapon at a time, so if you want to switch you have to steal a new one from your opponent. This adds a layer of rock-paper-scissors strategy. For example, the lumbering power of the veil quickly takes out weaker opponents, but flying baddies are less of a nuisance if you're using the gale. You can survive with any weapon, but deciding which is the best for each situation will distinguish the best players.

Stealing weapons also becomes an important way of cleansing your armament of choice. The more hell-bound opponents you take out, the more corrupted your weapon becomes, making it weaker against future baddies. In order to power up, you need to cleanse it, which normally requires standing still and leaving yourself open to attack. However, if you disarm an opponent mid-battle, the weapon you steal is automatically cleansed, providing a quick way to strengthen your attacks during long combat sequences.

In between combat, Enoch navigates colorful levels, each of which is based on the ideal world of the fallen angel inhabiting it. The light 3D platforming breaks up the combat but isn't likely to be a highlight. However, the quality of

the brief 2D sidescrolling interludes may surprise some gamers.

In these cartoonish, kaleidoscopic segments, Enoch tackles dangerous platforming challenges. Your equipped weapon also has some effect here. For example, Enoch moves slower while wearing the veil, which can make longer jumps more difficult. The arch allows Enoch to modify his jump with a floating fall, slightly extending his jump length.

The 2D areas are populated with the bizarrely adorable nephilim, the warped offspring of humans and angels. These charming, child-like creatures serve as both allies and obstacles for Enoch, floating by in balloons, pushing beach balls, and occasionally trying to devour the heavenly adventurer.

All of these details don't even get into the element that turned me onto *El Shaddai* in the first place: the half-serious, half-tongue-in-cheek writing. Even in the few brief outscenes I watched, the tone feels unique. It's not as serious as most Western action games, but it's also not as off-the-wall as *Bayonetta* or *Devil May Cry*—not yet, at least. We'll find out if the game's sense of humor and gameplay hold up for the entire journey when *El Shaddai* releases later this year. » **Phil Kollar**

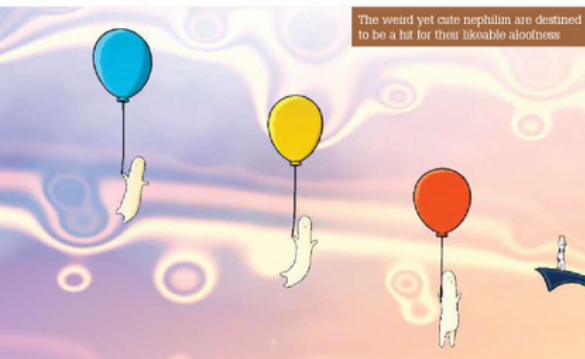

The weird yet cute nephilim are destined to be a hit for their likable aloofness

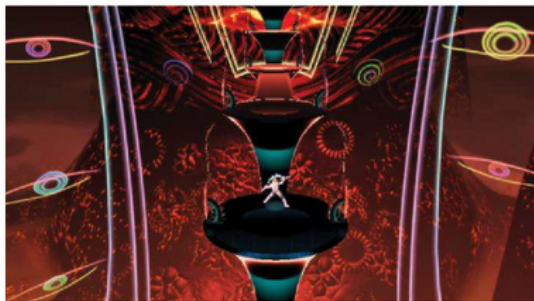

The dude with the weird giant eyeball is Sariel, one of the fallen angels Enoch is hunting. They'll show up to mock him before confrontations

# LESS VIRTUAL. MORE REALITY.

Merge the real world and the game world with augmented reality games included on the Nintendo 3DS system. Simply place the AR Card faceup and watch as the surface morphs and a 3D dragon leaps to life right before your eyes. Then fire away. Plus, explore a world of 3D entertainment with games, photos and more. No glasses required.

NINTENDO **3DS**

TAKE A LOOK INSIDE



[Nintendo3DS.com](http://Nintendo3DS.com)

Use Parental Controls to restrict 3D mode for children 6 and under.  
© 2011 Nintendo. Nintendo 3DS is a trademark of Nintendo. Simulated  
images of Nintendo 3DS system and augmented reality game. AR Cards  
included with Nintendo 3DS system.

# Transformers: Dark of the Moon

A Transformers game for every type of fan



» **Platform**  
PlayStation 3  
Xbox 360

» **Style**  
1-Player Action  
(10-Player Online)

» **Publisher**  
Activision

» **Developer**  
High Moon Studios

» **Release**  
Summer

**T**ransformers: Dark of the Moon aims to please every kind of Transformers fan. If you enjoyed last year's *War For Cybertron*, congratulations: The new game will be developed by High Moon Studios once again and maintains the core gameplay of that title. If you're more into the action figures, you're in luck also, as *Dark of the Moon* features a third transformation type borrowed from the upcoming *Transformers Stealth Force* toy line. If you enjoy Michael Bay's film adaptations, the game serves as a prequel leading into the third film, which hits theaters this summer.

With High Moon trying to appeal to so many different fans' desires, how can they pull it off? First off, they're not changing what worked in the last game. Despite taking place in a different timeline and setting, *Dark of the Moon* retains *War For Cybertron's* *Gears of War*-inspired run-and-gun gameplay. As with the last go-round, Transformers can switch between vehicle and robot mode at any time with the press of a button.

One unknown is how vehicles control in the new game. Since *High Moon's* last title was set on the Transformer home planet of Cybertron, car and tank transformations had a more sci-fi feel, hovering slightly above the ground and allowing players to easily strafe left or right while driving. Since *Dark of the Moon* takes place on Earth—at least the bits we've seen so far—the robots turn into more conventional vehicles, so it's unclear if the feel of driving will be affected.

We're also not sure what to expect from the new *Stealth Force* mode, a third transformation that is available to the robots in disguise. Despite using the word "stealth," this mode emphasizes heavier weaponry—a sort of middle ground between the speedier vehicle forms and the all-out assault of robot forms. This third transformation could add another layer of strategy onto the game, providing players with more tools for the situations they encounter—assuming it's not just a redundant form shoehorned in to help sell the new toy line.

Another benefit of *War For Cybertron's* other-

worldly setting was the opportunity to create sleek, clean, and robotic environments; they looked beautiful even when there wasn't much activity. All of the screens of *Dark of the Moon* we've seen so far feature Earth settings that look relatively detailed, but it's hard to tell if they'll hold up in motion. If nothing else, the new setting provides environmental variety; the Autobots and Decepticons will globetrot to a number of locations throughout the course of the game, including Siberia, South America, and, uh...Detroit. How excited!

Online multiplayer also returns, though *High Moon* is holding off on details. We expect to see popular game types like campaign co-op, the wave-based *Escalation* mode, and classic deathmatch and team deathmatch, but we won't know for sure until closer to the game's release, which is planned around the movie's July 1 arrival. Watch for further details, including hands-on impressions, in the coming months. » **Phil Kollar**



Ironhide

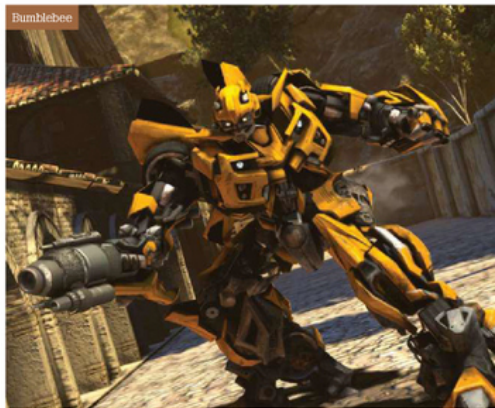

Bumblebee

# Dead Island

First-person melee set against a ruined paradise

Nearly four years ago, developer Techland announced that it was working on a zombie-themed game named Dead Island. Shortly after, the game went dark. I checked in with the studio periodically over the years and got a few e-mails of the "We're still working on it, that's all we can say" variety, but I cynically assumed that the game was either dead or dying. I should have known better, considering the subject matter.

Let's be blunt: Zombies aren't exactly as fresh a gameplay concept now as they were in 2007. By now, even some of the most die-hard fans of the undead may be suffering the effects of zombie fatigue. Fortunately for Techland and publisher Deep Silver Interactive, Dead Island is doing more than grabbing a dated concept and shoe-horning a few thousand ghouls into it.

Successful zombie stories are as much about the survivors coping with their new reality as they are about the undead who inhabit it. Circumstances such as a zombie apocalypse require people from all walks of life to set aside their differences and work together to survive—or die trying. Dead Island lets up to four players join up and test their fate in a doomed paradise off the fictional island of Banoi, set near Papua, New Guinea. Each player picks from four playable archetypes—tank, leader, jack of all trades, and assassin—and then the zombie slaying starts.

Dead Island merges first-person action with light RPG elements. Your character will level up as you gain experience in combat and by helping fellow survivors with missions. Players can then choose new abilities through the game's skill-tree system, which includes power-ups like the increased likelihood of scoring critical hits and more exotic skills such as Payback, which temporarily makes players perform more damaging attacks after getting hit themselves.

You start out at the Royal Palms Resort, which was a lush paradise before the mysterious infestation took hold. Now that the undead have taken over, players have to take advantage of their environments if they want to survive. While ordinary weapons are scattered around the world, they're appropriately scarce. Players instead must scour their surroundings for

improvised weapons such as iron pipes, broom handles, and paddles. Each varies in terms of range, strength, and durability, and their attack animations are different from one another as well.

The zombies are horrible-looking creatures, and it's clear the tropical climate has helped rush the decomposition process. They're pretty spiky, too, which gives players an incentive to aim melee attacks toward zombie limbs. Arms and legs can be broken and disabled, or parts and pieces can be completely sliced off if your weapon has a sharp enough blade. In addition to regular zombies, which include folks on vacation and resort staff, I saw a straightjacketed type from a nearby hospital. He didn't let his inability to use his arms get in the way, choosing instead to rush toward the player in a bullish charge.

Dead Island is still a ways from release, but I was impressed with what I saw. The focus on melee combat is an interesting idea, and it lends a sense of urgency and desperation to each encounter. Zombies have a tendency to swarm and overrun players, so you'll have to keep an eye out for an exit at all times. If Techland can balance that feeling of terror with game mechanics that don't feel cheap, Dead Island could very much be worth exploring. — Jeff Cork

- » **Platform**  
PlayStation 3  
Xbox 360 • PC
- » **Style**  
1-4 Player Action
- » **Publisher**  
Deep Silver
- » **Developer**  
Techland
- » **Release**  
Winter

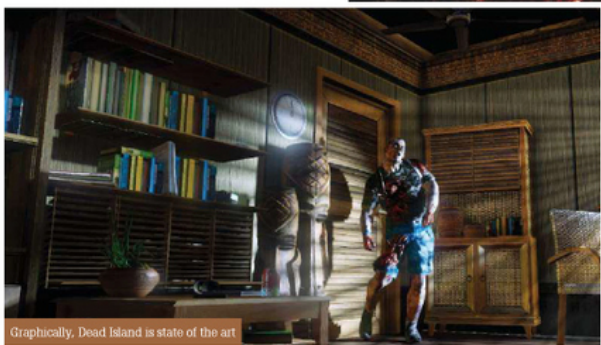

Graphically, Dead Island is state of the art

The calm before the storm



"I knew PriceLine.com sounded too good to be true."





# Resistance 3

Insomniac hands over the controls and sheds light on a new multiplayer approach

» **Platform**  
PlayStation 3

» **Style**  
1-Player Shooter  
[2-Player Co-op,  
16-Player Online]

» **Publisher**  
Sony Computer  
Entertainment

» **Developer**  
Insomniac Games

» **Release**  
September 6

Several months have passed since we first featured *Resistance 3* on our cover, and it's time to check in with Insomniac's shooter sequel. We finally got our hands on the game to experience the desperate struggle of Joe Capelli and the other survivors in a brutal world dominated by Chimera.

We join Capelli as a Chimera death squad assaults Haven, Oklahoma, the small town where our hero's family is scraping out an existence. Enemy dropships glow with unnatural yellow light as Hybrids leap to the ground. As we scroll through the revamped weapon wheel to select the trusty carbine, memories of *Resistance: Fall of Man*'s portable armory return.

Taking aim on the nearest Chimera's cooling pack, we fire and send the beast to the ground in a shower of sparks.

Not until rapid whirlwinds lift debris off the ground do we notice a huge, ominous needle stretching from sky to earth miles away. They call it a terraformer, a monstrous machination the Chimera are using to plow this newly conquered world. More pressing threats arrive as a dropship unloads a pack of Long Legs – a new breed of Chimera designed to leap through the air and rain death from above. We switch to the Bullseye and fire a tracking tag to ensure every round finds its way to our foe's putrid flesh. Upon firing the next tag, we notice it now splinters into numerous shards which stick to nearby enemies, allowing us to easily gun down the rest of the jumping freaks. "We want the game to be really action-oriented," explains creative director Marcus Smith. "We're going to reward you with the upgrade instantly while you're in the middle of battle so you can see the effects change instantly."

The earth begins to tremble before the last smoking Long Legs corpse hits the ground. Suddenly a gigantic, never-before-seen Chimera dubbed the Brawler bursts through a pile of wrecked cars, flinging them about like toys. Before we have a chance to react, the wretched, armored hulk flings us across the battlefield and into the side of a building. Deciding not to test our matador skills on the charging enemy, we climb to the structure's roof and use the healthpacks there. We then use the advanced Chimeran technology of the wall-piercing Auger to view vulnerable pieces of the Brawler's armor. The upgraded three-round burst makes short work of its defenses, but before we can deliver the kill shot the huge beast tracks down our elevated position and clambers onto the roof.

Switching to our reliable magnum, we empty all chambers into the beast's exposed flesh, ushering in the end of the Brawler and our time with the campaign.

After the demo, Insomniac also shed some light on *Resistance 3*'s revamped multiplayer. The studio ditched the gigantic, 60-player online wars of *Resistance 2* in favor of tight 16-player matches. So far Insomniac has only revealed team deathmatch mode, which takes place on more condensed maps inspired by the Subway and Bus Yard arenas from the first game. The only known multiplayer map as of now is a blood-soaked prison in the Republic of Chad, Africa. Insomniac wants battles to be more personal, and for players to feel the "lug of war" of battle with every death and kill.

Player progression is key in multiplayer. Insomniac offers combatants incentive for staying in the heat of battle, including unlockable support and tactical abilities. You can aid your allies with abeacon that replenishes ammo, a bubble shield to provide cover, and a radar beacon that shows player positions. Tactical abilities include a radar decoy to befuddle enemies, a lightning shield that zaps nearby foes, and a distracting doppelganger. A number of personal attributes can be earned as well, including the Visual Health Indicator, which makes health bars appear on players, and Leaper Corpse, which causes deadly critters to spring from your body upon death.

Our time with *Resistance 3* shows that Insomniac is trying hard to reclaim the phenomenal experience of *Resistance: Fall of Man* while improving upon the original formula. We couldn't be happier with how the game is progressing, and it's bound to get more interesting as Capelli nears Chimera-infested New York. » **Tim Turi**





# Final Fantasy Versus XIII

Checking in with the other XIII

Square announced Final Fantasy Versus XIII alongside Final Fantasy XIII at E3 2006. Nearly five years later, Versus XIII is still in development, while its counterpart already has a sequel nearing completion. It may be progressing at a slower pace, but based on the information and trailers Square Enix has released for Versus XIII, it is no less exciting than a traditional numbered Final Fantasy release.

Directed by Tetsuya Nomura, the mind behind the Kingdom Hearts series, Versus XIII takes a more action-oriented approach to combat. Instead of just entering commands like a turn-based RPG, players need skill and quick reflexes to adapt to the rapidly changing battlefield. An encounter might involve sending an enemy flying backwards with a lightning attack, then quickly switching to another character to hit the airborne foe with sword slashes, then switching again to deal the finishing blow with a ranged shot.

Players have a variety of different maneuvers at their disposal, including series staples like magic, items, and summons. Recent screens also display a command called "EX Arts," but Square Enix has not yet revealed how they function.

Stringing attacks together is a key element of the battle system, but the gameplay is more than just mashing buttons. Other factors can influence your combat strategy, like the day/night cycle that changes the enemies in the surrounding environments. You also come across unique sequences that offer completely different mechanics; in one trailer, we see the main character, Noctis, hop into a turret and mow down a wave of advancing soldiers. Later, Noctis also pilots a missile-equipped bipedal mech – so the odds of combat getting stale are low.

The world of Versus XIII is considerably more advanced than the one in Final Fantasy XIII. Noctis lives in a modern-looking city that resembles Tokyo, but a variety of futuristic and fantasy aspects still give it a slightly alien feel. For instance, even though Noctis drives around in cars and hangs out in skyscrapers, he also rides aboard airships and fights hulking behemoths in the middle of the highway. How exactly these elements weave together is unclear; Square Enix is guarding plot details very closely.

For the moment, Final Fantasy Versus XIII remains a PlayStation 3 exclusive, but rumors point toward the possibility of it going multiplatform. Square Enix has not yet committed to a release date, but key staff members have expressed doubt that the game will hit in 2011. Pencil this one in somewhere on your 2012 calendar. » **Joe Juba**

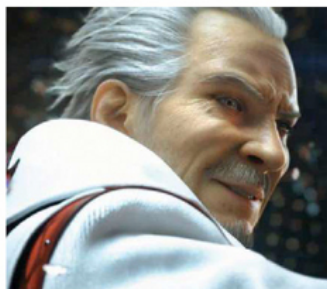

» **Platform**  
PlayStation 3

» **Style**  
1-Player Action/RPG

» **Publisher**  
Square Enix

» **Developer**  
Square Enix

» **Release**  
TBA

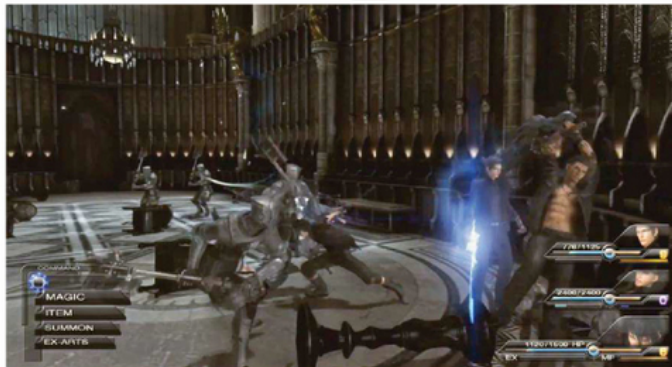

# SSX Deadly Descents

EA carves a mountainous experience

The character creator from SSX On Tour is gone. EA Canada wants to focus on developing SSX's stable of characters, all of whom will have their own abilities and equipment.

» **Platform**  
PlayStation 3  
Xbox 360

» **Style**  
1-player Action/Sports  
(Online TBA)

» **Publisher**  
Electronic Arts

» **Developer**  
EA Canada

» **Release**  
2012

When EA debuted its new SSX game at the Spike Video Game awards, fans feared that the series was straying from its roots in favor of a more realistic, darker edge.

From its perspective, developer EA Canada is taking everything that made the original SSX snowboarding titles great and shaping it into something relevant in today's market. SSX Deadly Descents (which is likely not the game's final title) features a global collection of around 70 mountains for players to race down, and boasts significant upgrades to the trick and upgrade systems. We talked with creative director Todd Batty, who melted many of the fears we had regarding the franchise's long-awaited new entry. — **Ben Reeves**



Go to [www.gameinformer.com/mag](http://www.gameinformer.com/mag) to read our full interview with creative director Todd Batty about SSX's exciting return.

**We know the game still features racing and trick events, but the Deadly Descent events are new. How do they work?**

In Deadly Descent the mountain is against you. It's more like an action game experience. If you look at past SSX games you had huge chasms that you could jump. We wanted to do more things like that, but ramp up the intensity. SSX 3 kind of had an avalanche, but we thought we could do that a thousand times better with the new systems. We have an amazing avalanche design. So we'll have more things like avalanches, rockslides, and falling stalactites. In Deadly Descent the challenge will be just making it to the bottom alive. The overarching goal of the game is to work your way up from a junior boarder and survive the Nine Deadly Descents. We're thinking of them like they were boss challenges.

**You guys are branching out and covering more mountain ranges than past titles. How big is this game going to be?**

We wanted to give people the amount of content that mega hits like Red Dead Redemption and Grand Theft Auto deliver. So in the early days we started sourcing topography data for the entire planet Earth. Our main menu is a 3D model of the planet with 18 different mountain ranges highlighted across the globe - Alaska, Antarctica, Siberia, the Calanques mountains, the Andes, the Alps, Kilimanjaro, and Mount Fuji. We're taking you all over the planet. We're a little challenged with how many levels we can put on the disc, honestly, but we're thinking it will be somewhere in the vicinity of 70 mountains. By comparison, SSX 3 had one. The hub works kind of like Google Earth. You can spin the globe around and pick a mountain range you like, then zoom in on that and pick a mountain you like from there. Then you get to race down the crazy arcade courses that we've built on top of real life mountains.

**The trailer showed off equipment like wing suits and pickaxes. Are tools like this part of a larger design system?**

Wing suits are really cool - it's probably the coolest new mechanic we've put in our game. In the past, players were able to trick out their characters with new gear, but aside from a board that might let you go a little bit faster, most of the gear that you put on your character was strictly aesthetic. We want to really invest in the gear, so you can earn a bunch of new gear that gives you new mechanics in the game. Ice axes let you do things like a wall vault move in Prince of Persia. Say you jump across a 150 foot chasm and you almost make it but you slide off the edge; instead of falling to your doom, you can smash those ice axes into the wall, vault yourself up, and keep going.

**Since SSX has been away for so long, have you found that you needed to make changes to the trick system?**

Well first off, we want players to be able to ride anywhere, at anytime, and vault into the air at ridiculous speeds and heights, and we want players to be able to flip and spin and roll on any axis to create an infinite amount of tricks. Then we layer in all the grabs, kick flips, and all the other over-the-top tricks that SSX is famous for. We've looked at games like Trials HD, which have a more fluid and natural system. What they did was a kind of two-dimensional physics, so you could flip and twist your bike around at any range or speed. We're taking that same feeling and bringing it into three dimensions.



EA Canada isn't willing to talk about it yet, but it did confirm the this new SSX would feature some kind of multiplayer component

gameformer  
**GAME OF THE MONTH**



**Total War: Shogun 2**

gameformer  
**GAME OF THE MONTH**

**84 Bulletstorm**

People Can Fly combines its sadistic tendencies with Epic Games' pristine polish to bring you an opus of gratuitous violence. Standard headshots mean nothing in the world of Bulletstorm, where you're rewarded for dispatching enemies in the most humiliating and creative ways. Forget what you know about cookie-cutter shooters, this is a callback to raw, unfiltered fun.

## THE SCORING SYSTEM

<b>10</b>	Outstanding. A truly elite title that is nearly perfect in every way. This score is given out rarely and indicates a game that cannot be missed.	<b>5</b>	Flawed. It may be obvious that the game has lots of potential, but its most engaging features could be undeniably flawed or not integrated into the experience.
<b>9</b>	Superb. Just shy of gaming nirvana, this score is a high recommendation because the game reviewed is head-and-shoulders above its competition.	<b>4</b>	Bad. While some things work as planned, the majority of this title either malfunctions or it is so dull that the game falls short as a whole.
<b>8</b>	Very Good. Innovative, but perhaps not the right choice for everyone. This score indicates that there are many good things to be had, but arguably so.	<b>3</b>	Painful. If there is anything that's redeeming in a game of this caliber, it's buried beneath agonizing gameplay and uneven execution in its features or theme.
<b>7</b>	Average. The game's features may work, but are nothing that even casual players haven't seen before. A decent game from beginning to end.	<b>2</b>	Broken. Basically unplayable. This game is so insufficient in execution that any value would be derived in extremely small quantities, if at all.
<b>6</b>	Limited Appeal. Although there may be fans of games receiving this score, many will be left yearning for a more rewarding game experience.	<b>1</b>	Spider-Man musical. Seriously, What the hell?

## AWARDS

gameformer <b>PLATINUM</b>	Awarded to games that score between 9.75 and 10
gameformer <b>GOLD</b>	Awarded to games that score between 9 and 9.5
gameformer <b>SILVER</b>	Awarded to games that score between 8.5 and 8.75
gameformer <b>GAME OF THE MONTH</b>	The award for the most outstanding game in the issue



Quinton "Rampage" Jackson  
Boost Mobile Athlete

# seek your unlimited

\$50 monthly unlimited with the samsung seek<sup>®</sup>

unlimited nationwide talk, text, web, 411, IM & email.  
no contracts. nationwide sprint<sup>®</sup> network.



For every 6 on-time payments Boost will lower your payment by \$5 per month to as low as \$35/month.

Int'l services extra. Customers must sign up for a plan with Shrinkage to become eligible for plan discounts. Shrinkage plan discounts awarded in \$5 increments after 6 timely and confirmed monthly payments made on customer's monthly payment date; total on-time confirmed monthly payments must exceed the total monthly payment amount for 6 months of Monthly Unlimited service to receive each \$5 incremental plan discount. Eligible plan discounts will not be restored upon reactivation if account is cancelled. Payment date will be the day of the month that you activate service on your phone or the last day of the month, as applicable. However, if your service is suspended or terminated, your payment date will change to the day of the month before the date you reactivate services (e.g., if you reactivate services on the 15th your payment date will be on the 14th) except reactivations made at the end or the first of the month (i.e., 30th, 31st or 1st) will result in varied payment dates contingent on the last calendar day of the month. Activation of service will occur when you have sufficient funds in your account to fulfill your monthly payment. Your payment must be made in full within 90 days of service interruption to resume service or your account & service will be cancelled. If your account is cancelled, you will lose all funds in your account balance & your telephone number. A \$10 reactivation fee will apply. Payments are made by adding funds to your account & your account balance must contain funds equal to or greater than the monthly payment amount no later than 11:59 PM the night of your monthly payment date or service may be interrupted due to non-payment. Account balance is decreased as monthly payments are due & services not included in the monthly plans are used. Payment amount does not include incidentals, including, but not limited to, int'l calls, wireless entertainment & downloads. Data speeds & voice experience vary by device selected & by network. Coverage is not available everywhere. Offers subject to change without notice & not available in all markets/retail locations or for all phones. Prohibited network use rules apply. See in-store materials or boostmobile.com specific prohibited use and add'l terms & details. ©2011 Zuffa, LLC. All rights reserved.

# Bulletstorm

The FPS genre gets a billion shots in the arm

9.25

PS3 • 360 • PC

## » Concept

Bulletstorm delivers a boot-full of variety and originality to the stagnating FPS genre

## Graphics

Masterful animations, stunning backdrops, and a vibrant color palette assault the senses

## Sound

Your ears will be treated to snappy dialogue, top-notch voiceovers, and blood-pumping metal riffs

## Playability

The game controls like a dream, allowing you to easily unleash nightmares upon your foes

## Entertainment

Perfect for fans of penis jokes, swearing, gore, and tight gameplay

## Replay Value

High



gamerformers  
GAME OF THE MONTH

gamerformers  
GOLD

Style 1-Player Shooter (4-Player Online) Publisher Electronic Arts  
Developer People Can Fly/Epic Games Release February 22 ESRB M

Do you remember the first time you shot an explosive barrel? That sharp blast not only heralded gamers' infatuation with reducing enemies to pulpy puddles, it also laid the foundation for interactive environments in shooters. Clever gunmen have trained their sights on red barrels and other hazards for decades, learning the language of creative carnage. All you know about killing with style using your surroundings has been a prelude to the bloody playground of Bulletstorm.

Going into a game called Bulletstorm I expected a paper-thin story as an excuse for nonstop murder. Instead, I was greeted with a humorous, potty-mouthed opening that fleshes out the dramatic crash-landing of ornery fugitive Grayson Hunt. His quest for revenge on corrupt military leader Sarrano is a gooly sci-fi romp that doesn't deserve to have its cutscenes skipped.

Bulletstorm offers a degree of character control I haven't experienced in an FPS since Mirror's Edge. Gray's kick, slide, and leash allow him to move through and interact with the environment

with fluidity. In other games, it would be unthinkable to pull a foe from across the map, strap him with explosives, kick him back into his buddies, and slide away while detonating the bloody mess. Amazing moments like this are easy to pull off in Bulletstorm. The slow-mo effect applied to enemies after being kicked or leashed offers the perfect window of opportunity to boot them towards electric wires or cacti, and the game has a predictive way of guiding the poor soul where you wish. There were only a few instances where I accidentally impaled some sad sack with rebar instead of feeding them to a carnivorous plant. Other than that, racking up points with creative skill shots is a reliably cathartic experience.

Skillshots are necessary to gain points to spend on weapon upgrades and ammo, but they're riotous fun in their own right. Working similarly to trophies and achievements, players earn hundreds of points by dispatching foes according to dozens of general and weapon-specific criteria. For example, the "French Revolution" skillshot is pulled off by decapitating multiple foes with a chain flail, and "Fan-tastic" is earned by launching a foe into the air and impaling him into the ceiling with a rotating spike, turning him into a human fan. The weapons themselves are some of the most creative and entertaining I've seen outside of an *Insomniac* title, including a quadruple-barreled shotgun that evaporates enemies like the playground scene from *Terminator 2*. Combine these weapon challenges with the general thrill of combat and you'll be hard-pressed to find a mundane encounter.

When you're not mowing through legions of foes, you're dropped into larger-than-life moments, like one that has Gray fleeing a tremendous runaway cog on a tram while you blast gas tanks to knock the wheel off course.

In another scenario Gray giddily guides a remote-controlled Mecha Godzilla lookalike through a miniature city, blasting apart buildings and enemies.

In addition to the single-player campaign, Bulletstorm offers Echoes and Anarchy modes. Echoes takes sections from single-player maps and lets friends compete with each other for the highest score. Knocking friends down the ladder is a nice distraction, but only score fiends will want to play this after beating the main game. Anarchy is a cooperative horde mode in which four players work together to earn skill points to progress through waves. Playing catch with foes using the leash and teaming up to kick a jerk into a gigantic dino's maw is a good time, but the higher level waves are impossible without constant communication. Hooking up four consoles in a room among good friends is your best bet, but even then the handful of maps start to feel repetitive after your tenth time attempting to get past wave 15.

Bulletstorm is an exceptional shooter brimming with personality and originality, but the concept is spread too thin in the later levels. New homicidal toys are constantly introduced in the first three-quarters of the game, which makes the final few hours a little stale. Mix in a ho-hum ending and the stellar experience goes out on a bit of a low note.

Small gripes aside, there's no denying Bulletstorm's blissful action. Epic Games/People Can Fly's sadistic opus arrives at a time when most shooters do little more than let you blast dudes in the head while things explode. Bulletstorm has those things, but also lets you shoot a man in the testicles and kick slide his head off. » **Tim Turi**

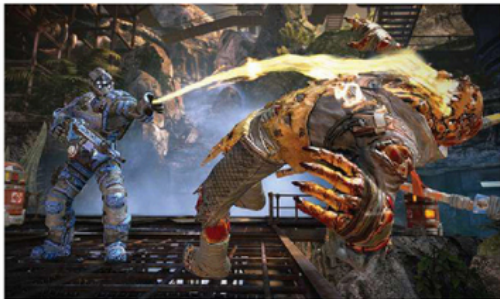

# Dragon Age II

Amid gameplay improvements, BioWare leaves story behind



Style 1-Player Action/RPG Publisher Electronic Arts Developer BioWare Release March 8 ESRB M

The console version of Dragon Age: Origins didn't have the same magic as its PC counterpart. The story, characters, and quests were all the same, but the thrill of battle was damaged during the transition. Addressing this problem is the greatest strength of Dragon Age II; by implementing a combat system tailored to console gameplay, BioWare's epic fantasy series takes a new shape. This changed vision for the franchise may disappoint hardcore fans of the original, but the sequel still delivers—though not in the ways you'd expect.

BioWare's template story structure involving an intro, four main quest hubs, and a finale is nowhere to be found in Dragon Age II. Unfortunately, no compelling story rises to take its place. Framing the story with another character's narration, Dragon Age II attempts to tell the tale of Hawke's rise to power in Kirkwall. In execution, this story amounts to little more than a bunch of sidequests lashed together. They are rarely connected to a central goal, and since the main plot has no arc, you get little sense of mounting tension or rising stakes until the climax is upon you.

Most of the missions are short, in-and-out affairs that involve traveling between Kirkwall's painfully limited number of locations. While the city is supposedly huge, you only bounce between about 10 areas and a handful of buildings and caves within them. By the fourth or fifth time I was sent down to Darktown to resolve shady business, I was pining for the vast forests of Ferelden. Speaking of Ferelden, you can import your save from Origins, but it just alters some dialogue and a few cameos so don't expect constant references to your previous exploits.

Your surroundings get old quickly, but most quests have a clever spark that keeps the entertainment value high. I hunted a serial killer, took a jaunt into the Fade, and watched an ally awkwardly blow a date with her ideal man. A few mundane missions fill in the gaps (prepare to kill a lot of slavers), but the inventive scenarios and excellent writing are among the highlights in Dragon Age II. The tasks you perform for your party members are particularly cool, aided by the fact that your companions are more interesting characters than those in Dragon Age: Origins.

The biggest change from the first game is the combat. No longer trying to straddle the fence between tactical and action-focused systems, Dragon Age II gives itself over entirely to fast-paced, responsive battles. This drastic departure from the original formula is bound to upset purists, but it suits the game well. Throwing down a non-stop barrage of spells and weapon techniques is empowering, and since you aren't just issuing commands and waiting for their execution, the action feels more immediate. Don't expect this sensation right away, though; you'll have to play for several hours before you have enough abilities to keep combat interesting. In the early stages, you'll burn through your meager skills and then mash the attack button while you wait for them to recharge. I promise, it gets better. By the time you're wiping out your opposition before they even hit your front lines, it all seems worth it.

Aside from combat, an array of smaller tweaks make this sequel better suited for console play than its predecessor. The Mass Effect-like conversation system gives Hawke a voice and keeps the dialogue flowing, though it also removes some of the moral ambiguity. BioWare has tuned

the combat difficulty to require minimal micro-management, but this comes at the expense of the pause-and-play approach (which is technically still possible, but totally useless). Inventory and equipment are easier to manage, and the new skill trees—while heavily simplified—help differentiate characters and give them unique roles in combat. I also encountered some technical issues like enemy pop-in and graphical hiccups, but they rarely hampered my enjoyment.

Part of me was disappointed with Dragon Age II. I hoped for an improvement on the original, but it ultimately feels like a step back. The new battle system is fun, but not nearly as satisfying or rewarding as Origins'. Since you don't even have a main antagonist until the final hours, the story pales in comparison to the original. If you put those complaints aside and remove Dragon Age II from the impressive shadow of its predecessor, you'll find an engaging action/RPG experience that still retains BioWare's trademark clever dialogue, cool characters, and detailed lore. » **Joe Juba**



## 8.25

PS3 • 360

» **Concept**  
Create a more action-packed, accessible Dragon Age

**Graphics**

Looks better than last time, but the environments still seem bland in spite of a new art style

**Sound**

Quality voice work and a suitable fantasy soundtrack

**Playability**

Responsive controls and a streamlined interface work well on consoles

**Entertainment**

The story and battle system are less satisfying than the original, but they still provide plenty of fun

**Replay Value**

Moderately High

### What About PC?

This review only pertains to the Xbox 360 and PS3 versions of Dragon Age II. This may seem strange since the original's definitive version was on PC, but that is not the case with this entry. Even on PC, Dragon Age II is essentially a sequel to the console version of Dragon Age: Origins. The PC version does not feature the zoomed-out isometric view of its predecessor, and combat still has the new action-centric design. The two versions have enough differences to merit separate reviews, but don't expect the PC entry to be head-and-shoulders above the competition this time. You can read the full review of the PC version online at [gameinformer.com/mag](http://gameinformer.com/mag).

# Knights Contract

A bewitching story hindered by a nagging gameplay

7

PS3 • 360

## » Concept

A witch and an immortal stir up trouble for demons and gamers alike

## Graphics

Vivid comic book colors and exotic creature designs blend to create a striking visual style. The cutscene animations are lifeless by comparison

## Sound

Heinrich reminds me too much of Frankenstein's monster, whereas the voice actor for Gretchen is a perfect fit. The soundtrack complements the mood nicely

## Playability

The combat mechanics are similar to fellow games in the genre, but with an added weight to Heinrich's attacks. Magic mixes up the combat chemistry nicely

## Entertainment

Too much babysitting is required, but when you are not fishing Gretchen out of a lava pit, the unique gameplay shines and the story delivers in a big way

## Replay Value

Low



Style 1-Player Action Publisher Namco Bandai Developer Game Republic Release February 22 ESRB M

Knights Contract's Heinrich is the antithesis of your typical video game protagonist. He's old, arthritic, and scarred from head-to-toe. He walks with a limp, and every word he utters carries the sorrow of a lifetime of depression. He's unlikable – intentionally so, perhaps – but the reasoning behind his state of mind and the means to cure it drives his story forward.

Heinrich once served as an executioner that specialized in beheading witches. Through periodic flashback sequences we see Heinrich carrying out the orders of Faust, a power-hungry dictator hell bent on purifying the land. One of the witches touched by Heinrich's scythe, named Gretchen, showed no fear. With her head resting gently on a wooden stump, she casts a curse on Heinrich before he can lop off her head. Heinrich became immortal. This may seem like a blessing, but when we meet Heinrich for the first time, he's lived enough.

When I stepped into his tattered garb, my first instinct was to gift him with the death he sought. I lowered my guard and let a pack of monsters tear the flesh off of his hulking frame. They left nothing but his two legs – cut off just below the knees. The disturbing spectacle didn't last long, however. By jamming on a button I reunited flesh with bone and brought him back to fighting form. Death cannot stop him.

His scythe strikes are slow and sloppy, an appropriate fit for his appearance. His foes, which range from armor-dad knights to skyscraper-sized snakes, could make short work of him (repeatedly), but he doesn't fight alone. Gretchen is resurrected, and as fate would have it, she is forced to work with her killer.

The duo works well together, each offering strengths where the other has weaknesses. Gretchen is a powerful witch who can entangle foes in a magical brier, summon meteor showers, and make razor-sharp blades appear from the earth. When she's had enough (as dictated by a power meter), she can grow to giant's size and crush a foe in her hands or between her thighs. The spells she casts are satisfying, violent, and just a hair shy from being as outrageous as those unleashed in Sega's beloved witch simulator, *Bayonetta*.

The player controls only Heinrich's physical movements, yet handles the attacks for both characters. Heinrich's abilities are mapped on the face buttons; holding down the right trigger transforms the buttons to Gretchen's attacks. The battles are fast paced, and even the smallest of encounters can be a heart-pounding challenge.

Heinrich's melee attacks don't deal nearly as much damage as Gretchen's magic, but he has a deep list of combo chains at his disposal – very much in line with other genre heavyweights like *God of War* and *Devil May Cry*. Performing well in combat rewards the duo with valuable experience points that can be used to upgrade all of the spells. Game Republic did a great job of balancing the upgrade progression, and each one feels like a significant boost.

No matter how powerful the duo becomes, the challenge revolves around keeping Gretchen alive thanks to her incompetent AI. She stands in fire, runs headlong into a boss's grip, and performs so many ill-advised actions I'm convinced she could never cross a street on her own. If she

perishes, it's game over.

With her bumbling motions taking center stage, the game devolves into a ten-hour long escort mission. The only way to heal her is for Heinrich to pick her up and weave through hostile forces like an NFL running back until her health regenerates. Coming to her aid isn't so easy, either. When Heinrich falls in battle, it takes time for him to reanimate; foes wisely use this lull to beat the snot out of the most defenseless witch to ever walk the Earth. Equipment found in the world can make her more durable, but nothing improves her poor judgment.

Clashes with demons also run the risk of ending abruptly due to archaic design, such as an instant game over if Heinrich is knocked off of a ledge. This happens all too often, especially during boss fights. Worse yet, players must deliver the final blow to bosses via quick-time events. If you don't nail all of the sequences correctly, the boss is rewarded one-third of its health back. Once depleted (again), you have to try the same quick time sequence over.

Heinrich and Gretchen's journey is tiresome, but when the game works the way it should – with Gretchen being far removed from harm's way, and Heinrich navigating ledge-free areas – the duo creates a wonderfully chaotic storm on the battlefield that empowers the player with the feeling of being unstoppable.

Even when the game seems to be working against me at every inopportune time, the drive to see the fate of Heinrich and Gretchen made me push forward. I'm glad I did. I didn't see the ending coming, and I love how the story concludes. **Andrew Reiner**



# Fight Night Champion

A dramatic finish in a fight to the top



Style 1 or 2-Player Sports (2-Player Online) Publisher EA Sports Developer EA Canada Release March 1 ESRB M

I suspect that although most people don't consider themselves boxing fans, the sport resonates with us because it's been delivered successfully via a story – whether that's *Rocky*, *Raging Bull*, or even Mike Tyson's *Punch-Out!*. Therefore, the Fight Night franchise is the perfect place to do something gamers have wanted for years – create more drama in sports games. Champion mode's tale of Andre Bishop and the characters that surround him is an excellent blend of gameplay and writing, with each one complementing the other to produce a step forward for the genre.

You can't win a fight with just one kind of punch, and Champion mode throws enough effective combos to be a formidable fighter. The voice actors convey the story well, and their characters are rendered with enough detail and subtlety to convey emotion and drama. For a video game to deliver on all these fronts is a minor miracle by itself, but part of what helps the mode work so well is that it's not just a string of regular matches bookended by cutscenes. EA Canada tweaks gameplay parameters of certain bouts in Champion mode to mix things up. Sometimes your goal is only to survive for a few rounds, or maybe you have to KO an opponent instead of winning by decision. The reasons behind these staged situations vary. Sometimes it's to teach you about the gameplay, but usually it's to serve the arc of the story – whose flashbacks, colorful characters, and occasional surprises work well because they are handled deftly enough to be believable within the story as well as the gameplay.

Fight Night Champion is almost two games in one, because the Champion mode doesn't take away anything from the core Legacy mode from past games. The revamped career mode features an updated training regime and pre-

fight scheduling. Like in the ring, survival and success is a matter of managing your stamina. Cash-generating sponsorship events, marketing opportunities for increasing your fighter's popularity, pre-fight training, and even injuries must be managed in the days and weeks leading up to your next fight. Pack your schedule with too many activities, and you might enter your next bout with the tank half-empty.

I liked the scheduling aspect of Legacy mode, but the training and subsequent XP allocation is confusing. Different training camps around the globe bump up your physical attributes in predetermined ways, but individual training minigames do not. While this means you don't have to do minigames you don't like, it also undercuts a reason for having different ones in the first place. Similarly, you can assign the XP you get throughout the mode to a range of specific offensive,

defensive, and health-related skills (like a left upper cut to the head), but you can't inflict certain damage states (critical stun, flash knockdown, etc.) until you reach appropriate skill thresholds. While I agree that you aren't going to be flash KO-ing opponents from the start, having to meet these minimum levels means that early on regular knockouts are hard to come by, which isn't very realistic.

With such impressive game modes, it's easy to overlook the improvements to the already great gameplay. EA streamlined the controls for punches, dodges, and blocks without compromising the

game's overall strategy – which now takes stamina into account better. Although your control inputs are often faithfully replicated onscreen, I am surprised how many times weaker miss-hits (where a boxer's arm wouldn't fully extend) register as powerful punches capable of knocking someone out. I can't figure out the rhyme or reason behind the flash knockout system either, but the excellent degenerative defensive system is a solid improvement.

With online gyms comprised of your friends, smart gameplay changes, and improvements to Legacy mode, Fight Night Champion is more than your usual collection of modest EA Sports improvements. Some areas shine brighter than others, but the developer's inspired Champion mode is the star feature that must be experienced. » **Matthew Kato**



Legacy mode's worldwide training gyms are also venues for special events like sparring matches which can boost your attributes and popularity

## 9

PS3 • 360

### » Concept

Introduce a new story mode as well as improvements in the controls and other areas

### Graphics

Nuances in the facial animations for the characters in Champion mode bring home the drama

### Sound

The voice work for Champion mode is well done, and the announcers do an awesome job conveying story points, strategy, and the suspense of the fight

### Playability

The simplified controls are awesome to work with and don't dumb down the game at all

### Entertainment

Fight Night Champion connects with its story mode, even if a few punches miss

### Replay Value

High

# de Blob 2

A super-saturated adventure

8

PS3 • 360 • Wii

#### Concept

De Blob spearheads a revolution against an oppressive regime to restore harmony to the urban paradise

#### Graphics

The HD editions are a visual feast of colors, shapes, and patterns. As expected, the Wii version's graphics are less impressive, but the art direction lends itself well to the console

#### Sound

While somewhat limited in scope, the pleasant jazz-inspired tunes swell as you rejuvenate the world, adding auditory feedback to player progression

#### Playability

Bonus challenges and completion rewards ensure entertainment for players of all skill levels, but boss battles and puzzles rarely test your skills. Platforming is formidable in later levels, and the occasional camera or targeting hiccup is frustrating

#### Entertainment

Blue Tongue's ambitious sequel presents a Pixar-like entertainment for all ages. The charming and sometimes juvenile capers of Blob are contrasted by surprisingly mature conflicts involving religious brainwashing, rigged elections, unlawful imprisonment, and martial law

#### Replay Value

Moderate



Each new location is a blank canvas waiting to be revived

Style 1 or 2-Player Action Publisher THQ Developer Blue Tongue Entertainment Release February 22 ESRB E10+

Comrade Black is back, and so is his wicked war on color. While we had a handful of critiques for Blue Tongue's Wii-exclusive release, *de Blob* was one of the better-received third-party titles on the console. Recognizing the potential to capture a broader audience, THQ is wisely going multiplatform with *de Blob 2*.

*De Blob 2*'s world is saturated with color and personality. As you bring Prisma City back to life by eliminating enemies, freeing prisoners, solving puzzles, and painting the environment in a color-by-numbers manner, propaganda disappears and trash vanishes. The hustle and bustle of daily life returns, erasing any signs of a once-monotone existence. *De Blob 2* literally runs on an economy of inspiration, awarding you light bulbs that can be spent to upgrade your silent—but thoroughly expressive—protagonist with more health, better defense, and increased paint capacity.

The action can feel repetitive at times, but it's rarely unfulfilling. Blue Tongue meticulously crafted the pacing, introducing new hazards, enemies, and power-ups just as the surprisingly lengthy game begins to teeter on monotony. The well-designed user interface also helps completionists track down that last bit of foliage that needs coloring or the final imprisoned citizen that needs freeing, which lets players avoid wandering the busy cityscape aimlessly.

The game plays virtually the same across all consoles, and doesn't force gesture controls on the primary player despite Wii and Move compatibility, which I appreciate considering the precision needed in later platforming levels. That being said, the occasional camera issue mars an otherwise enjoyable experience. The camera adjusts unexpectedly, and one time re-oriented *de Blob* off a cliff during one of the tougher platforming segments. The frustration is compounded by a somewhat sporadic checkpoint

system, which at times restarted me back in a nearly whitewashed level. These hiccups are the exceptions rather than the rule, as the bulk of *de Blob 2*'s mechanics are well developed.

Multiplayer challenges and a co-op mode position *de Blob 2* as an optimal shared experience for a parent and young child. The *Super Mario Galaxy*-esque co-op allows the second player to paint objects and foes as Blob's sidekick Pinky, which helps less-skilled gamers contribute to the experience in a meaningful manner without being overwhelmed by the difficulty of later levels.

Because of its lighthearted nature and presentation, *de Blob 2* may pass under the radar of "core" gamers, which would be a crime worthy of the INKT Corporation. Fun, innovative, and surprisingly deep, *de Blob 2* is bright spot in a sea of gray games and iterative sequels. **» Meagan Marie**

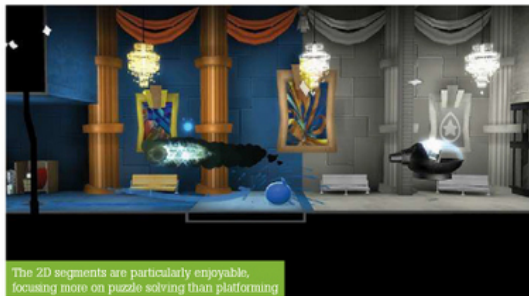

The 2D segments are particularly enjoyable, focusing more on puzzle solving than platforming



The targeting system is extremely intuitive and encourages chaining together attacks



## Yoostar 2

A fun, cinematic experience undermined by poor technical implementation

**Style** 1 or 2-Player Simulation **Publisher** Yoostar Entertainment Group  
**Developer** Blitz Games Studios **Release** March 8 **ESRB** T

Yoostar 2, like its PC predecessor, is a unique experience designed for movie buffs, aspiring stars, and everyday gamers alike. Its Kinect-enabled console debut uses the sensor bar's camera to place players in classic scenes to deliver lines with a karaoke-style interface. While the concept of turning everyday people into actors makes for an amusing time, technical issues stand in the way of making the latest Yoostar a blockbuster hit.

Yoostar 2 offers single- and multiplayer options, but the game is most enjoyable in a group setting. You can fly solo in the challenge mode and perform scenes like hitting the road to Chicago in *The Blues Brothers* or reporting a problem to Houston as Tom Hanks in *Apollo 13*. However, scenes where the default actor you replace only has a few lines become tedious. You get credit for patiently waiting your turn to speak, but the sensor occasionally picks up sounds other than your voice and docks points from your score, hindering your progress across the map to Hollywood. Sound recognition issues continue when a line is delivered as prompted, but is unrecognized by the

game. This becomes less of a problem in the quick play mode, where you're playing more for fun and less for high scores.

Quick play offers 50 movie scenes for you to perform alone or with friends. The selection is impressive, with a wide range of genres for film and TV fans of any generation. Sing "In The Air Tonight" while throwing down air drums and delivering a punch as Mike Tyson in *The Hangover*, shout "This is Sparta!" in *300*, or "make him an offer he can't refuse" in *The Godfather*. Watching yourself and a friend in these scenes and delivering lines is hilarious, and the ability to save the clips and upload them to social networking sites is a nice touch. However, even in the ideal Kinect play space you have to awkwardly position yourself to fit perfectly in the film frames, and the grainy picture quality mars your celluloid performances.

Despite its technical imperfections, Yoostar 2 can be enjoyable if you step out of your shell and be a total ham. Bring in some friends for a full cast, and you'll get some laughs during your acting debut. **» Annette Gonzalez**

## 6

360

### » Concept

With the Kinect sensor, movie buffs replace actors in classic scenes to perform memorable dialogue

### Graphics

Even in ideal lighting and space conditions, your appearance in full movie scenes looks grainy

### Sound

Lines by original actors are dubbed over by the sound of your own voice

### Playability

Menu navigation is sluggish, and fitting your body in suggested frames for scenes makes for awkward positioning

### Entertainment

For the optimal experience, Yoostar 2 is best served with a group of friends

### Replay Value

Moderate

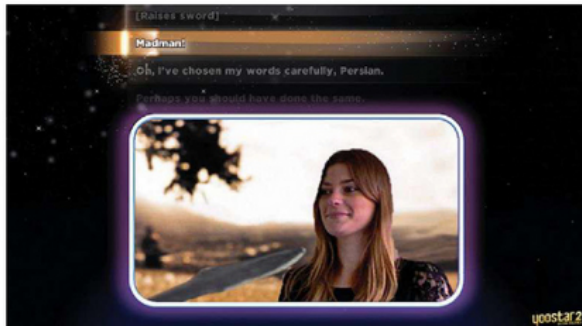

# geeked at birth



Please geek responsibly.

You may speak the language,  
but are you geeked?

Here's a chance to prove it.

**Yoostar**

ADVANCING COMPUTER SCIENCE

ARTIFICIAL LIFE PROGRAMMING

DIGITAL MEDIA

DIGITAL VIDEO

ENTERPRISE SOFTWARE DEVELOPMENT

GAME ART AND ANIMATION

GAME DESIGN

GAME PROGRAMMING

HUMAN-COMPUTER INTERACTION

NETWORK ENGINEERING

NETWORK SECURITY

OPEN SOURCE TECHNOLOGIES

ROBOTICS AND EMBEDDED SYSTEMS

SERIOUS GAMES AND SIMULATION

STRATEGIC TECHNOLOGY DEVELOPMENT

TECHNOLOGY FORENSICS

TECHNOLOGY PRODUCT DESIGN

TECHNOLOGY STUDIES

VIRTUAL MODELING AND DESIGN

WEB AND SOCIAL MEDIA TECHNOLOGIES

www.uat.edu > 877.UAT.GEEK

# MLB 11: The Show

The closest you can come to playing the sport without sustaining injury

9.25



Style 1 to 4-Player Sports (4-Player Online) Publisher Sony Computer Entertainment  
Developer Sony Computer Entertainment San Diego Release March 8 ESRB E

PS3

## » Concept

After delivering broadcast quality visuals last season, Sony puts the authenticity of the sport into the player's hands

## Graphics

Realistic enough to fool three Game Informer editors into thinking it was a live baseball broadcast

## Sound

The commentary team does a better job of following the action this year, but they repeat some of their lines far too often

## Playability

A whole new ballgame that now utilizes an analog control scheme. The pitching mechanic is hands-down the best yet. Making contact is a bit easy, however

## Entertainment

Not your typical yearly iteration. Sony made changes all across the diamond, and almost all of them are for the better

## Replay Value

High

My beloved Chicago Cubs are three outs away from forcing a divisional tie with the Cincinnati Reds. I've turned to Carlos Marmol and his filthy slider to shut down the Dodgers. Only two runs have crossed the plate all game, both coming off a mistake Jon Garland served up to Aramis Ramirez. The fans at Wrigley Field are losing their minds. The electric atmosphere screams of playoff baseball. My nerves are fried, the controller in my hands slick with sweat. The Cubs' season hangs on my ability to place my pitches.

The first batter I face is Casey Blake. His better years are behind him, and he's hitting a career low .235 for the season. My first pitch, a knee-high slider, snaps the corner for a strike. For the next pitch, Geovany Soto, the Cubs' reliable catcher, slides to the inside of the plate and calls for the heat. I agree with the call, and put a little extra mustard on it. My follow-through is just a hair off, and the ball catches too much plate. Blake jumps on the mistake and slaps a base hit to left field. Marmol is noticeably rattled. He wipes sweat away from his brow, and takes a few extra steps behind the mound to regain his composure.

I won't walk you through every pitch in this at bat, but creating realistic baseball moments like this is what MLB 11: The Show is all about. Most of this drama is driven by the game's new analog-based gameplay, and the studio's ability to make almost every little detail – whether it's the AI reacting logically to a good pitch, or an animation depicting convincing player emotions – true to the sport.

The new analog pitching is the most polished and challenging gameplay mechanic a baseball game has ever offered. It's all about finesse and finding a rhythm with different pitch types. To place pitches on the corners, you have to angle the analog stick in the direction of the desired location. The gesture must be fluid and gentle, the video game equivalent of threading a needle. Depending on where you are aiming, the



slightest error could result in a ball or worse – a pitch that hangs over the plate. The length of your motions is tied to your pitcher's delivery; the amount of time allotted is shorter when working from the stretch, making finesse pitching all that much more difficult. I felt stressed when batters would get on base. I even got so out of sync at times that I would get called for balks.

This new system not only offers a great challenge, it accurately simulates pitch counts. If just one pitch isn't working for you, expect to walk batters and reach deep counts. Most of my starters threw between 80 and 105 pitches in five to nine innings of work.

The new batting mechanic requires similarly exact motions, pulling the right analog stick back to plant the foot, then pushing it forward to swing. Unlike pitching, however, it's easy to grasp and master. Even on the higher difficulty settings, I didn't strike out very often. I didn't find the new contact swing modifier useful, as the power swing gave me the same results or better. My contact ratio was absurdly high, but my hits per nine ranged around a realistic 12 to 15, resulting in five to six runs. These totals were usually far lower when facing an ace.

Fielding uses analog-based controls as well, but the action isn't that much different than last season outside of the new option to take throws and lure players into rundowns. Rather, defense is most noticeably improved in the number of ways the fielders react. A distinct difference exists between outfielder and infielder motions, and players show a better awareness of their location on the field. They position themselves to play caroms and turf bounces, and will hit the dirt if they are in the way of one of their teammates' throws across the diamond.

Road to the Show remains one of the most addictive and satisfying modes in video game sports. This year, a slider system allows you to build the frame for the type of player you want

to be. Developing your ballplayer no longer relies on an arbitrary set of in-game goals; you now earn experience points for every at bat or batter faced. The amount of points you tally is determined by your performance for that situation. If you perform great all game long, you're going to be rolling in points, and your player's development takes the appropriate leap forward. New training minigames also give nice bumps to specific skills. I still want more interaction with my manager, not to mention a more comprehensive look at how I'm doing both within the organization and league-wide.

Acting as a coach manager, I simulated five seasons of Franchise mode. Trade logic is much smarter this year, but may be too persistent. In one season, the Braves proposed a trade for my Cubbies' stud shortstop Starlin Castro. Their first offer was a player-for-player deal. I turned it down. They came back two days later with a two-player deal. The day after that they came back with a three-man option. In total, they threw together seven different packages for Castro. I rejected them all. Outside of dealing with bully AI, Franchise's multi-roster player management is easy to comprehend, and I love that the game allows you to make difficult (and often questionable) decisions with injured players.

The Show won Game Informer's Sports Game of the Year honors last year, and the product Sony put on the field this season takes a dramatic step forward in many meaningful areas. Even after 50 to 60 games played, I was still seeing new animations on the field, and the commentators were telling different stories about my team. Although I wanted more challenge from the batting, the new analog pitching controls should be experienced by every baseball enthusiast. » **Anrew Reiner**

To read an extended review that goes into more detail about the game modes, visit [www.gameinformer.com/mag](http://www.gameinformer.com/mag)



MLB 11 supports 3D, and you can use the Move controller for the Home Run Derby competitions

# Killzone 3

The strongest entry in the franchise is also the best reason to own Move

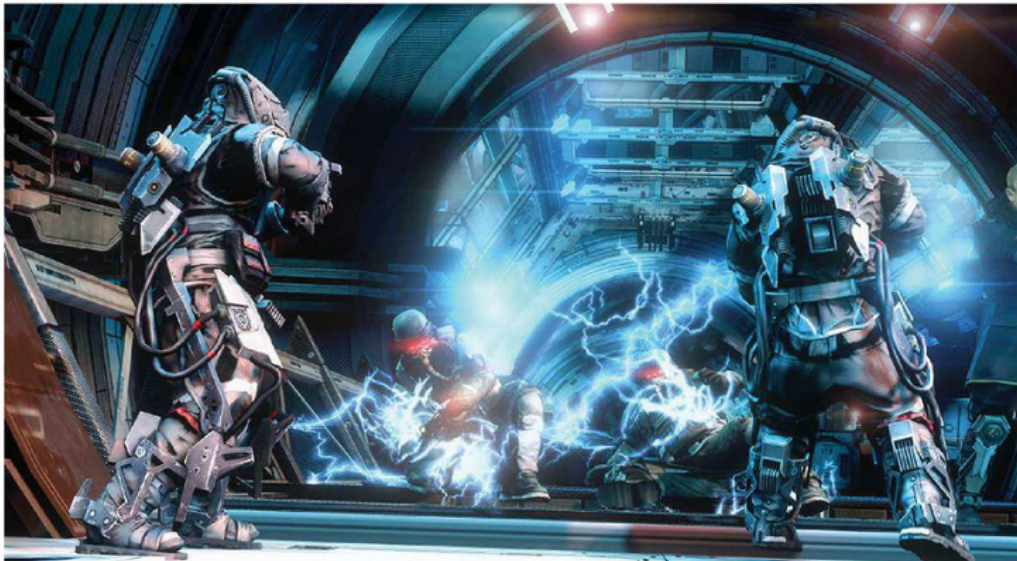

Style 1 or 2-Player Shooter (24-Player Online) **Publisher** Sony Computer Entertainment  
**Developer** Guerilla Games **Release** February 22 **ESRB** M

Like repeated shots of adrenaline, Killzone 3 juices you up and pushes you into chaos again and again. This newest installment fulfills the promise of the franchise through action-packed set piece encounters, electrifying gameplay, and surprising environments. While Guerilla Games still struggles to find a sense of pacing, and storytelling largely consists of people shouting incomprehensible things at each other, it's easy to ignore the paper-thin plotting given all the strapnel and gunfire zooming past your head.

The game picks up right after the finale of Killzone 2. Sev is standing by Rico despite his moronic decision to martyr the Helghast's supreme leader. Now, the ISA troops are caught behind enemy lines on the hostile planet. While the story follows a few meaningful threads, every emotion and moment is ratcheted up to such an extreme that it's hard to know what to care about. Some characters shout every single word of dialogue they speak, and that sense of constant insanity carries over into gameplay. Most of the game runs with the amp turned to eleven, so when the cool explosions, deaths, and plot reveals happen, they don't carry the impact they might otherwise have had. That said, as I mentioned in my review of Killzone 2, it's hard to complain too much about high-octane action in a sci-fi shooter.

The gameplay that accompanies this bombastic plotline is taut and thrilling. Gunplay exchanges are fast and merciless; it's hard to find a safe place to hide amid the crumbling walls and shattered vehicles of Helghan. Enemy

AI is brutal even on the default difficulty, and will happily shoot you to hell for a momentary lapse in positioning. The game rewards an aggressive approach to the battlefield; players that can clear the area quickly before the enemy digs in will win the day. At the same time, cover is essential as you hurry forward. A balanced game of offense and defense is a must. The great selection of weapons is a lot of fun, though most players may stick with the excellent ISA assault rifle for much of the game. My favorite addition is a high-power missile launcher with an alternate fire that calls down artillery strikes.

As you hop from one battlefield to the next, Guerilla does a great job of breaking up the action. From mech and other vehicle sections to some of the best aerial rail shooting sequences I've ever encountered, the plentiful short exchanges help keep things fresh. The jetpack in particular makes you feel powerful and dangerous without unbalancing the combat. One of the best parts of the game comes halfway in, when a brief stealth sequence is punctuated by frightening action moments any time you get spotted. A few more variations in tempo like that, and the broader pacing problem in the storytelling would be solved.

Technically, Killzone 3 reaches a new benchmark for which other games should strive. The graphical fidelity is high despite the overload of activity taking place onscreen at any one time. It's a visual smorgasbord of action and lights, filled with oversaturated colors that are likely a response to critiques that found the earlier games too drab. Stack on all the independently

moving characters and vehicles, and the game is a sight to behold.

The visual splendor and tight gameplay carry over into an excellent multiplayer component. The class and leveling mechanic offers customization options, but the real enjoyment comes from the objective-based game modes, which task teams with completing goals across vast battlefields. The best of these game types include interstitial cutscenes that move the mission forward, starring the best players from the group. Players more familiar with whittling away space marine energy shields will be in for a shock at how fast a duel can go down; if your preference is that momentary thrill of trigger finger against trigger finger, you should be pleased.

All the other ingredients are in place for a blockbuster shooter. The great controls are responsive and customizable, even with the new Move alternative (see sidebar). A bot mode lets players familiarize themselves with multiplayer maps before going online. Two-player local co-op lets you enjoy the campaign with a friend, though it disappointingly lacks online support. The game even packs impressive stereoscopic 3D if you happen to have the necessary display.

Killzone 3's shocking and abrupt campaign ending serves as a suitable wrap to Guerilla's extended war-themed trilogy. Even if it is a conclusion of sorts, Killzone 3 stands on its own. The franchise has always fallen just shy of greatness for me. This time, there's plenty for any action gamer to dig his or her teeth into. » **Matt Miller**

## 9

PS3

### » Concept

Survive behind enemy lines from one explosive first-person battle to the next

### Graphics

More action unfolds across the screen than any comparable game, and it all looks gorgeous in that "demolished by the ravages of war" sort of way

### Sound

A phenomenal soundtrack is buried beneath overly intrusive sound effects and shouting. Adjust your audio levels accordingly

### Playability

No matter your control scheme, Killzone 3 feels intuitive and responsive

### Entertainment

With its latest installment, the franchise gives the other big shooters a run for their money, and adds fantastic motion controls to the mix

### Replay Value

Moderate

### The Motion Factor

As the first true test of Sony's Move controller for dedicated gamers, Killzone 3 doesn't just pass the bar; it leaps far above it. Playing the game with the new peripheral feels natural and enjoyable, and at times offers an even better gaming experience than a traditional controller. Guerilla managed the task by designing with the Move in mind. Fun rail shooting sequences, well-designed static battlefields, smart button mapping, and excellent customization options all contribute to a fun all-around play experience. Tack on the excitement of feeling like you're actually aiming the gun and pulling the trigger, and Killzone 3 makes the best argument I've yet seen for the viability of motion controls in a high intensity game. A few pieces of advice: Don't be afraid to recalibrate when aiming gets wonky, beware arm fatigue during long sessions, and turn off the vibration functionality for the sake of your precision and sanity.

# Total War: Shogun 2

A focused approach to total warfare is a winner

9.5

gamerformers  
GAME OF THE MONTH

gamerformers  
GOLD

Style 1-Player Strategy (4-Player Online) Publisher Sega  
Developer The Creative Assembly Release March 15 ESRB T

PC

## » Concept

Take the long-running historical strategy series back to its roots with a tight focus on Sengoku-era Japan

## » Graphics

Each season has its own particular beauty. A solid gaming PC makes a huge difference, though, as improved shadow and lighting effects take the visuals to the next level

## » Sound

The minimalist score didn't get turned off 10 hours into the game. The only other time that has happened with me was with Civilization IV's Grammy-winning soundtrack

## » Playability

It is hard to heap too many superlatives onto the campaign interface. It's vastly improved over the previous games

## » Entertainment

I didn't expect to be pulled back into Total War after burning out on Empire and Napoleon. Shogun 2 made me a believer all over again

## » Replay Value

High

The Creative Assembly has always reached for the stars with Total War, pushing the boundaries of what we thought technically possible to create ambitious grand strategy titles that mix internal politics, diplomacy, intrigue, economic development, and warfare. This ambition has often come at the price of rough edges, from unit AI during real-time battle sequences failing to navigate terrain to imperfect balancing and problematic rival faction AI on the turn-based campaign map. Shogun 2 is a repudiation of this development philosophy. It brings the scale down from Empire: Total War's globe-spanning theaters to three of feudal Japan's islands. Instead of dozens of countries and ethnicities bringing radically different troops to the battlefield, Japanese clans fight with minor variations of sword, bow, and spear. This cuts away the fluff that got in the way of exploring Total War's gripping strategy.

Stripping away the bloat that has crept into Total War over the franchise's many iterations has allowed Creative Assembly to explore the design of the core gameplay itself. Dominance over Japan requires building a strong infrastructure, picking your friends and enemies carefully, and ultimately seizing victory on the battlefield itself. Unlike previous Total War titles, each of these elements is elegantly designed as part of the greater whole. For example, choosing what type of buildings to build in each province is a series of decisions that leaves space for developing strategies (Market or archery dojo? Monastery or stables?) without burying the player in trivialities. Every button you press has an immediate,



noticeable effect. Upgrading a castle doesn't just add a percentage modifier to unit replenishment; it opens up another slot for economic or military buildings, adds stronger walls and defensive emplacements, and allows faster troop training. Instead of choosing between boring percentile increases here and there, you're unlocking powerful new abilities like double-speed samurai training or tripling town growth.

This streamlining extends to all areas of the game. The agents that do your bidding outside the field of battle have been reworked into rock-paper-scissors triangle that has ninjas, monks, and metsuke (secret police) dancing all over Japan in a shadow war. This simple yet engaging mechanic is a massive improvement over the overly complicated agent designs of Empire, Napoleon, and even Medieval II. Similarly, differences on the battlefield are between samurai and ashigaru (armed peasant), cavalry and infantry, or spear and sword. As much as I enjoyed Napoleon's artillery duels, battles in Shogun 2 are more satisfying because they leave more room for tactical creativity. Sieges finally work properly, as units do what they're told and the AI is an enthusiastic third-grader instead of a brain-damaged pole.

The introduction of honor gives diplomacy a new twist. Interacting with major and minor rivals has always been core to Total War, and having to consider your daimyo's honor gives everything a new weight. Renege on an alliance when a friendly clan is attacked, and you haven't just pissed them off – your honor takes a hit, which impacts everything from future diplomatic relations to your generals' loyalty and your peoples' attitude toward your rule. Conversely, forgoing immediate advantage in order to gain respect can pay big dividends down the road. I spend as much time mapping networks of alliances and

planning my diplomatic moves as I do building infrastructure or moving armies in Shogun 2, which I can't say of any other game.

The Creative Assembly put a huge amount of work into an unusual persistent multiplayer framework, where players can join clans and fight one-off battles in a league structure. Frankly, multiplayer Total War battles have never grabbed me because the control is so clunky and unresponsive that managing combat in real time is unbearably frustrating. This continues in Shogun 2. I like the metagame implementation in theory, and persistent rewards are always great, but the lackluster core gameplay keeps me away.

I admire how many legacy issues have been addressed, but some remain. Tactical naval combat is still so terrible that I autoresolve every single one. The land-based tactical AI still has a few holes you can exploit (see sidebar). A few parts of the interface, like not being able to see the wider diplomatic situation when a rival comes to you with a proposal, consistently frustrate. I will never understand why the game doesn't follow the standard turn-based model where units prompt you to give orders before hitting the end turn button – I've wasted dozens of army, navy, and agent moves by not scouring every corner of my empire.

Less truly is more when it comes to Total War. Shogun 2, with a smaller scale and tighter focus, boasts the best gameplay and design of any entry in the franchise. I can't imagine a realistic way that The Creative Assembly could have made a better case to win back fans put off by Empire (of which I wasn't one, though I understand the complaints many Total War fans have of that entry). It has made the game more approachable to new players without sacrificing the franchise's soul. » Adam Blesener

## Technical Difficulties?

The Creative Assembly was raked over the Internet's hottest coals thanks to the bugs, instability, and many technical difficulties of Empire: Total War. Napoleon shored up that rickety foundation, and was solid even if the AI was still easily exploitable in combat. Shogun 2 is an incremental improvement over Napoleon. The AI for both enemy generals and your units is much better in sieges, to the point that massive battles over multi-level fortresses are interesting and fun instead of an exercise in figuring out how to exploit a broken AI. On the campaign map, I saw rival clans successfully invade over water, blockade trade ports, and reinforce besieged cities. The AI still recruits masses of crappy units instead of more effective mixes of cannon fodder and elite troops, and the combat AI has a few holes still like picking the wrong ground to fight over and running its troops too hard. Having recently played a fair amount of Empire and Napoleon, though, the improvements make a significant difference. That said, I had more crashes than I am comfortable with on several different machines while reviewing Shogun 2. I'd advise downloading the demo to make sure the game runs reliably on your system before committing the money.

# Magicka

Play this in co-op or don't play it at all

**Style 1** to 4-Player Action [4-Player Online]  
**Publisher** Paradox Interactive **Developer**  
Arrowhead Games **Release** January 25 **ESRB** T

The last time I had this much stupid fun blowing things up in a video game was years ago with Painkiller. My time with Magicka was cut short before I'd had my fill of its flexible combat system, though, and not because of any impending deadline. Single-player becomes unplayable due to horrid level design halfway through, and technical problems continue to mar online co-op.

The plot doesn't do anything more than make a few *Star Wars* and *300* jokes along the way to setting up a few thousand enemies between you and some kind of existential threat to the world, and the game lacks most common RPG elements. You have no mana bar, skill points, or potions. All that exists are the eight elements and the four ways to unleash them. Create volatile lightning walls, raise volcanic geysers, drop healing boulders from the sky - Magicka's combat system puts explosive creativity at your fingertips and rewards your experiments with enthusiastic animations of their deadly effects.

Investigative players will find discrete magicks with unusual effects, from Haste and Time Warp



to Rain and Blizzard. The best tactics tend to combine spells, magicks, and manual dodging. You can encase yourself in rock while Meteor Shower immolates everything on screen, conjure blocking boulders around you and call lightning from the sky, and more.

For the first half of the adventure, Magicka presents a well-paced, pleasant variety of combat situations that encourage you to explore the destructive potential of your wizard's staff. The level design inexplicably abandons single-player balance halfway through the game, turning this easy-breezy, enemy-exploding arcade game into a controller-smashing slog. Powering

through the worst bits is punishing with a few friends to help you out; only the most masochistic gamers will make it through in single-player.

The level design stupidity can't stop Magicka's brilliant core gameplay from shining through. At its best, tearing hordes of enemies limb from limb with a buddy flinging spells beside you feels like playing Double Dragon on a flaming helicopter flying through a tornado with a pilot on his 50th cup of coffee. That doesn't excuse the bits that are best compared to Battletoads' legendarily frustrating hoverbike sequence, but I'm not going to pretend like I didn't get my \$10 and more out of the game. » **Adam Biessener**

# 7.5

PC

#### » Concept

Mix eight elements into powerful, explosively hilarious spells that never discriminate between friend and foe

#### Graphics

The bright, inviting style suits the lighthearted gameplay well. It's technically competent enough not to be distracting

#### Sound

Swedish Chef-style gibberish voiceovers are a perfect match for the tongue-in-cheek story

#### Playability

A control scheme that forces you to manually enter each element in sequence to achieve the desired effect sounds dumb on paper, but it only adds to the engaging chaos in practice

#### Entertainment

If only single-player were playable past the halfway point, this would be one of the best \$10 games ever

#### Replay Value

Moderate

## FIFA INTERACTIVE WORLD CUP 2011

THE WORLD'S LARGEST FOOTBALL GAMING TOURNAMENT



EA SPORTS™ FIFA 11 ON PLAYSTATION®3

REPRESENT YOUR COUNTRY AND WIN A TRIP TO THE FIFA BALLON D'OR

COMPETE AGAINST THE BEST PLAYERS IN THE WORLD



# PLAY YOUR PART!

REGISTER IN-GAME NOW  
[WWW.FIFA.COM/FIWC](http://WWW.FIFA.COM/FIWC)



PS3  
PlayStation 3



© 2008 FIFA™

# Super Street Fighter IV 3D Edition

The same great game, only smaller

9

3DS

## » Concept

Bring Super Street Fighter IV to Nintendo's new handheld with a few 3D enhancements and a new accessible control scheme

## Graphics

Character models are big and detailed, and the 3D effect is slick. It's a shame about those backgrounds, though

## Sound

All the tunes from the console versions are here, and they sound great

## Playability

This is the most accessible Street Fighter in decades. The optional lite control scheme lets novices perform even the trickiest moves with ease

## Entertainment

It might be smaller, but as far as gameplay goes, this has everything that its big brothers have and more

## Replay Value

High



Style 1 or 2-Player Fighting (2-Player Online) Publisher: Capcom Developer: Capcom Release: March 27 ESRB: T

## Figure Battles?

Capcom took advantage of the 3DS' StreetPass functionality with a fun little diversion called Figure Battles. Here, players can trade in points earned through playing the game or by racking up steps on the system's pedometer and buy Street Fighter figurines. Those figures can then be battled against other players' collections, earning more points. Some strategy is involved in setting up rosters and tweaking three skill categories, but it's pretty shallow. Aside from bragging rights from collecting the 500 figurines, there's no real reason to pour too much time into the mode.

It's hard to believe, but it's been nearly two decades since a Street Fighter game has appeared on a Nintendo system. More astonishingly, Capcom decided to break that dry spell by releasing Super Street Fighter IV on a portable system. The result is no simple gimmick, either.

Capcom has shown a remarkable amount of restraint in using the hardware's 3D effects. Dynamic Mode presentation adds visual depth by moving the action closer and positioning the camera behind characters' shoulders, but the changes won't make Blanka's eyes pop out in disbelief. Purists can enter the options and shut off 3D entirely—a move that doubles the refresh rate from 30 to 60 blisteringly fast frames per second. I expect people to use Dynamic mode to show off the game to their friends for the first time, then to switch to the traditional side view.

Even if you haven't kept up with Street Fighter movesets, you can do more than watch thanks to a new "lite" control option. This scheme allows players to turn the touchscreen into a series of customizable one-button triggers, letting even the greenest fighter pull off hadoukens and ultra combos with a single tap. Even if you're not a complete novice, it's a great way to learn how to play unfamiliar characters. If you're concerned about people dominating online with their newfound expertise, you can filter out players using lite controls through matchmaking.

Pros might scoff at that kind of control

scheme, and they can choose to stick with Pro controls. The touchscreen is still used, but it's mapped for more mundane tasks such as three button-press combos and focus attacks. Even with the relatively limited number of buttons on the 3DS, I pulled off moves in pro mode without a hitch. The system's circle pad is a godsend for

rotation-based moves like Zangief's spinning pile-driver. The positioning of the d-pad makes it easy to swap between it and the circle pad depending on the circumstances.

A few things were lost in the transition to the portable space, most disappointingly in the game's stages. They're all there, but the charming background activities were scrapped entirely. The kids who used to scamper and cheer on the fighters in the underpass level are now rigid 2D facades, for instance. A few other minor graphical details are missing, too, but you have to squint to see them. Rufus' belly might not jiggle quite as enthusiastically, but other graphical flourishes, like Hakan's oil-soaked shimmer and the translucent sleeves in Chun-Li's alternate costume, are intact.

Unlike the iPhone version of Street Fighter IV, which was an admirable effort that ultimately felt like a proof of concept, Super Street Fighter IV 3D Edition is a complete game. Super Street Fighter IV is one of the best fighting games around, and players owe it to themselves to give it a shot. » **Jeff Cork**

*Editor's Note: Online multiplayer wasn't available at the time of this review. We'll evaluate online multiplayer when the game launches and revisit the review, if necessary on gameinformer.com. Otherwise, consider this review to be our final word on the game.*

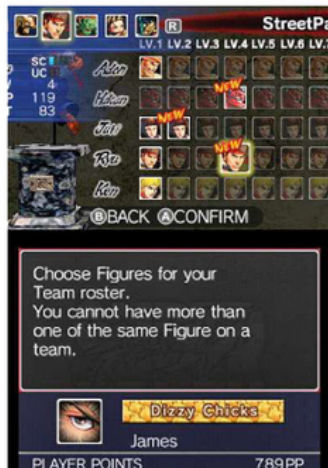





# Dissidia 012 Final Fantasy

Square Enix focuses on action instead of polish

**Style** 1-Player RPG/Fighting (2-Player Online)  
**Publisher** Square Enix **Developer** Square Enix  
**Release** March 22 ESRB T

7

The original Dissidia pitted an array of classic Final Fantasy characters against each other in fast-paced, haphazard combat. The transformation into a fighting game wasn't exactly a natural fit for an RPG series that has helped define video game storytelling for the last 20 years, but fans seemed to enjoy the opportunity to beat up their favorite villains and heroes. This sequel continues to serve those fans – and no one else.

The core concept isn't all that made the transition from the first game; the sloppy controls are back, too. Basic maneuvers like dashing and dodging are unreliable thanks to a button layout that you can't re-map (in a fighting game), and the awful camera is a more formidable foe than some opponents. Most battles are tuned so that you don't need to perform flawlessly, but a handful of boss fights made me absolutely furious by expecting a level of precision that the game cannot provide.

Most of the single-player mode isn't bad or frustrating; it's just dull. You repeatedly fight the same opponents, and the new overworld map is just more of a detour between grid-based levels similar to the last game. The thrill of leveling up, learning new abilities, and unlocking secrets is still here, but the surrounding gameplay is more mechanical than entertaining. The only time I felt the adrenaline pumping is when I was fighting a human opponent, which is easier this time around since multi-player is no longer local-only.

Despite its faults, the Final Fantasy fan in me had some great times with Dissidia 012. The new characters are solid additions to the roster; I particularly liked the twists that Yuna and Laguna bring to combat. The new assist system is good, too, adding an extra dimension that was missing the first time around. I also can't argue with the amount of content, since the story mode features three campaigns (though one is basically a re-hash of the original).

If you liked Dissidia, you will like Dissidia 012. Square Enix's minimal attempts to address the first game's issues won't win any new fans, but the company knows how to pander to an audience. That's one area where Dissidia 012 is firing on all cylinders. » **Joe Juba**



PSP

» **Concept**  
 More Final Fantasy characters enter the fray in this stylish sequel

**Graphics**  
 Character models and spell effects look cool, but the action can devolve into visual noise

**Sound**  
 An excellent voice cast, with almost everyone reprising their iconic roles

**Playability**  
 None of the control issues from last game were addressed, so expect some frustration

**Entertainment**  
 The action is impressive, and fans will love seeing their favorite characters battle, but the formula gets old quickly

**Replay Value**  
 Moderately High

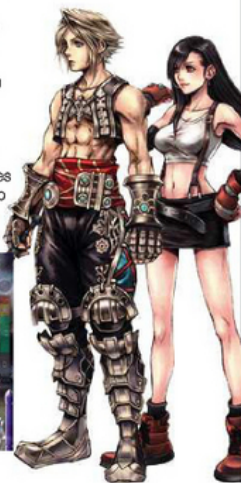

# Monster Tale

DreamRift delivers a unique monster mashup

**Style** 1-Player Action/Platforming **Publisher** Majesco  
**Entertainment Developer** DreamRift  
**Release** March 22 ESRB E

8

When a group of devious kids sneak into the Monster World and enslave its creatures, a young girl named Ellie comes to their rescue with the help of a rare monster named Chomp and a powerful bracelet. Monster Tale's cutesy demeanor and child-like themes may turn off some at first glance, but the genre-bending portable title offers a surprising amount of depth and gameplay variety.

Monster Tale provides light 2D platforming across five colorful locales, each with its own theme and enemy types (though you'll run into the occasional palette swap). To accomplish her goals, Ellie relies on her legendary bracelet, which doubles as a blaster weapon. Whether it's learning to roll under a row of spikes, or gaining the ability to perform a rapid-fire blast with a quick button combo, players must master and upgrade all of Ellie's skills to progress through the levels. Hand-eye coordination and reflexes are put to the test in later boss battles, which require successful execution of all skills acquired for a gratifying victory.

Chomp's role in Monster Tale adds a Pokémon-esque monster-raising element that makes excellent use of the handheld's dual screens. With a press of the X button, Chomp retreats to the "Pet Sanctuary" below to help Ellie activate puzzle switches, pick up items that provide experience for leveling, take down enemies that sneak below, and activate combat items like catapults and soccer balls to knock out enemies above. Being mindful of Chomp's activities on the lower screen while guiding Ellie through combat sequences above makes for fun, if occasionally chaotic, gameplay. Chomp can roam along with Ellie on the top screen as well to lend a hand with monsters for experience points. These unlock evolved forms of the creature, which are worth experimenting with during tougher skirmishes later in the game.

Monster Tale does a great job of leading you to your next objective on the map, but since the lower screen is primarily used as the Pet Sanctuary, I found myself regularly disrupting gameplay to check the map in the menu to ensure I was taking the most efficient route toward my goal. As you progress through the world, your next objective often requires tedious backtracking across several environments. Instead of giving the player new experiences, you're stuck revisiting familiar areas and fighting familiar enemies several times over.

Criticisms aside, Monster Tale is a polished platforming adventure with light RPG elements that make it more than just another pet simulator. It uses the aged DS hardware to full effect for a novel experience. » **Annette Gonzalez**

DS

» **Concept**  
 A young girl and her pet monster save enslaved critters from a group of evil children in a game that combines platforming, action/adventure, and light RPG elements

**Graphics**  
 Childhood-themed environments are colorful, detailed, and well designed

**Sound**  
 Each location has its own catchy tune

**Playability**  
 Skill progression moves along a steady curve. Abilities are put to the test during chaotic boss encounters

**Entertainment**  
 Despite its kid-friendly appearance, Monster Tale offers a surprising amount of engaging gameplay

**Replay Value**  
 Moderately Low

# reviews archive

## PLAYSTATION 3

Assassin's Creed: Brotherhood	9.25	Dec-10
Blade Kitten	6.5	Nov-10
Blood Drive	4.5	Jan-11
Call of Duty: Black Ops	9	Dec-10
Castlevania: Lords of Shadow	9	Nov-10
Comic Jumper: The Adventures of Captain Smiley	8	Oct-10
Costume Quest	6	Dec-10
Create	5	Jan-11
Dead Rising 2	9.5	Nov-10
Dead Space 2	9	Feb-11
DJ Hero 2	9.25	Dec-10
EA Sports MMA	8.5	Dec-10
Echochrome II	7.25	Feb-11
Enslaved: Odyssey to the West	7	Nov-10
F1 2010	8.5	Nov-10
Fallout: New Vegas	8.5	Dec-10
RFA 11	8.75	Nov-10
Fight: Lights Out, The	8.5	Jan-11
Front Mission Evolved	7.75	Oct-10
Gran Turismo 5	9	Feb-11
Guitar Hero: Warriors of Rock	8	Nov-10
Hard Corps: Uprising	9	Feb-11
Harry Potter and the Deathly Hallows: Part 1	5.5	Jan-11
HAWX 2	7.5	Oct-10
High Velocity Bowling	6	Oct-10
James Bond 007: Blood Stone	7.5	Dec-10
John Daly's ProStroke Golf	7.5	Nov-10
Kane & Lynch 2: Dog Days	6	Oct-10
Kung Fu Rider	3.5	Nov-10
Kung Fu Live	6.5	Feb-11
Lara Croft and the Guardian of Light	9	Sep-10
Legend of the Guardians: The Owls of Ga'Hoole	7.25	Nov-10

LittleBigPlanet 2	9.5	Feb-11
Madden NFL 11	8.75	Sep-10
Mafia II	9	Oct-10
Majin and the Forsaken Kingdom	8	Dec-10
Marvel Football	8.5	Jan-11
Marvel Super Hero Squad: The Infinity Gauntlet	6.75	Feb-11
Marvel vs. Capcom 3: Fate of Two Worlds	9.25	Mar-11
Mass Effect 2	8.5	Feb-11
Medal of Honor	7	Nov-10
Mindjack	5	Mar-11
Nai'd	8	Jan-11
NBA 2K11	8.75	Nov-10
Need for Speed Hot Pursuit	8.75	Dec-10
NHL 11	9	Oct-10
Pac-Man Championship Edition DX	9	Jan-11
R.U.S.E.	7.75	Oct-10
Racket Sports	5.5	Oct-10
Red Dead Redemption: Undead Nightmare	8	Dec-10
Rock Band 3	9.25	Nov-10
Rush'n Attack: Ex-Patriot	6	Mar-11
Saw II: Flash & Blood	4.5	Dec-10
Scott Pilgrim vs. The World	9	Oct-10
Sengoku Basara: Samurai Heroes	6.75	Dec-10
Shank	8	Oct-10
Shaun White Skateboarding	7.75	Dec-10
Shoot, The	6	Jan-11
Sims 3: The	9	Dec-10
Sonic the Hedgehog 4: Episode I	8	Nov-10
Spare Parts	6	Mar-11

## 9.25 | Marvel vs. Capcom 3: Fate of Two Worlds

Platform PS3 • 360 Release February 15 ESRB T Issue Mar '10

*Small gripes aside, you shouldn't pass on Marvel vs. Capcom 3 if you have even a passing interest in Capcom, Marvel, the fighting genre, or good games. This pugilistic prize has mimicked the polished, accessible reinvention of Street Fighter IV, forming another strong leg for the resurrected fighting genre to stand on. — Tim Turi*

Spider-Man: Shattered Dimensions	8.5	Oct-10
Spitterhouse	5	Feb-11
Sports Champion	7.75	Oct-10
Stacking	8.5	Mar-11
Star Wars: The Force Unleashed II	7.75	Nov-10
Start The Party	6	Oct-10
Test Drive Unlimited 2	8.5	Mar-11
Time Crisis: Razing Storm	6.75	Jan-11
Trinity: Souls of Zill Oll	6	Mar-11
Tron: Evolution	4.5	Jan-11
Tumble	8	Oct-10
Two Worlds II	7.75	Mar-11
Vanquish	7.75	Nov-10
WWE Smackdown vs. Raw 2011	8	Dec-10

You Don't Know Jack	8	Feb-11
---------------------	---	--------

## XBOX 360

A World Of Katlings	8.25	Jan-11
Arkania: Gothic 4	6.75	Dec-10
Assassin's Creed: Brotherhood	9.25	Dec-10
Biggest Loser: Ultimate Workout, The	8	Dec-10
Blade Kitten	6.5	Nov-10
Blood Drive	4.5	Jan-11
Body and Blain Connection	5	Mar-11
Call of Duty: Black Ops	9	Dec-10
Castlevania: Harmony of Despair	8.5	Sep-10
Castlevania: Lords of Shadow	9	Nov-10
Comic Jumper: The Adventures of Captain Smiley	8	Oct-10
Costume Quest	6	Dec-10

Create	5	Jan-11
Dance Central	8.75	Dec-10
DanceDanceDance	4	Jan-11
Dead Rising 2	9.5	Nov-10
Dead Rising 2: Case West	8	Feb-11
Dead Rising: Case Zero	8.75	Oct-10
Dead Space 2	9	Feb-11
DJ Hero 2	9.25	Dec-10
EA Sports MMA	8.5	Dec-10
Enslaved: Odyssey to the West	7	Nov-10
F1 2010	8.5	Nov-10
Fable III	9	Dec-10
Fairy: Legends of Avalon	6	Feb-11
Fallout: New Vegas	8.5	Dec-10
FIFA 11	8.75	Nov-10
Fighters Unleashed	4.5	Dec-10
Front Mission Evolved	7.75	Oct-10
Guitar Hero: Warriors of Rock	8	Nov-10
Halo: Reach	9.5	Oct-10
Hard Corps: Uprising	9	Feb-11
Harry Potter and the Deathly Hallows: Part 1	5.5	Jan-11
HAWX 2	7.5	Oct-10
Ironbik	8.5	Jan-11
James Bond 007: Blood Stone	7.5	Dec-10
John Daly's ProStroke Golf	7.5	Nov-10
Joy Ride	7	Jan-11
Kane & Lynch 2: Dog Days	6	Oct-10
Kinect Adventures	7.5	Jan-11
Kinect Sports	8	Jan-11
Kinectimals	8	Jan-11
Lara Croft and the Guardian of Light	9	Sep-10
Legend of the Guardians: The Owls of Ga'Hoole	7.25	Nov-10
Madden NFL 11	8.75	Sep-10
Mafia II	9	Oct-10

## the score

### 8.75 | Tales from Space: About a Blob

Platform PS3 Release February 8 ESRB E

*This is a polished and often challenging platformer. Nicely balanced between tricky jumping sequences, clever action puzzles, and the combat, About a Blob continues to unfold as you play on, layering on new mechanics and design tropes.*

— Matt Helgeson

### 7 | Dungeons

Platform PC Release February 10 ESRB M

*This unusual strategy title somehow manages to be less than the sum of its parts. I found myself scrambling around the map or hacking away at some one-off objective instead of carefully crafting my evil plans for optimum hero crushing.*

— Adam Biessener

### 9.25 | Beyond Good & Evil HD

Platform 360 Release March 2 ESRB T

*If you're among the majority of gamers who didn't play Beyond Good & Evil when it originally came out for PS2, Xbox, and GameCube, you have no excuse for passing up its new form.*

— Phil Kollar

### 7.25 | Swarm

Platform PS3 • 360 Release March 23 ESRB T

*Only a few light platforming and puzzle moments break up what is otherwise an orb-collecting march to the finish. The game fails to innovate on its early mechanics, and it can feel like a chore to master some of the later levels. It may be fun to watch these little guys die, but there were too many moments where I wanted to kill the power to my console.*

— Ben Reeves

### 7.25 | Bionic Commando Rearmed 2

Platform PS3 • 360 Release February 1 (PS3), February 2 (360) ESRB T

*I didn't like Rearmed 2 as much as the first game, but there's still plenty worth checking out. This isn't a play-instantly title, but it still ranks above Spencer's awful console reboot.*

— Bryan Vore

### 7.5 | Yar's Revenge

Platform PS3 • 360 • PC Release March 29 ESRB E10+

*The Atari classic re-launches as a fast-paced rail shooter on your downloadable platform of choice. Juggling different weapons and dodging enemy fire makes the gameplay feel frantic and exciting, but too little enemy and level design variation hold this competent shooter back from greatness.*

— Matt Miller

# TURN YOUR PASSION FOR GAMING INTO A CAREER

- Game Art**  
Bachelor's Degree Program  
Campus & Online
- Game Design**  
Master's Degree Program  
Campus
- Game Development**  
Bachelor's Degree Program  
Campus
- Game Design**  
Bachelor's Degree Program  
Online



- Campus Degrees**
  - Master's Entertainment Business Design
  - Bachelor's Computer Animation Digital Arts & Design Entertainment Business Film
  - Game Art
  - Game Development Music Business Recording Arts Show Production Web Design & Development
  - Associate's Graphic Design Recording Engineering
- Online Degrees**
  - Master's Creative Writing Education Media Design & Technology Entertainment Business Internet Marketing Media Design New Media Journalism
  - Bachelor's Computer Animation Creative Writing for Entertainment Digital Cinematography Entertainment Business
  - Game Art
  - Game Design Graphic Design Internet Marketing Mobile Development Music Business Music Production Sports Marketing & Media Web Design & Development



fullsail.edu

Winter Park, FL

800.226.7625 • 3300 University Boulevard

Financial aid available to those who qualify • Career development assistance  
Accredited University, ACCSC

Majin and the Forsaken Kingdom	8	Dec-10
Marvel Pinball	8.5	Jan-11
Marvel Super Hero Squad: The Infinity Gauntlet	6.75	Feb-11
Marvel vs. Capcom 3: Fate of Two Worlds	9.25	Mar-11
Medal of Honor	7	Nov-10
MinJack	5	Mar-11
Nai'd	8	Jan-11
NBA 2K11	6.75	Nov-10
NHL 11	9	Oct-10
Pac-Man Championship Edition DX	9	Jan-11
Pinball FX2	9	Jan-11
Plants vs. Zombies	9	Nov-10
R.U.S.E.	7.75	Oct-10
Red Dead Redemption: Undead Nightmare	8	Dec-10
Rock Band 3	9.25	Nov-10
Rush 'N' Attack Ex-Patriot	6	Mar-11
Saw II: Flash & Blood	4.5	Dec-10
Scott Pilgrim vs. The World	9	Oct-10
Shank	8	Oct-10
Shan White Skateboarding	7.75	Dec-10
Sims 3, The	9	Dec-10
Sonic Free Riders	5.75	Dec-10
Sonic the Hedgehog 4: Episode 1	6	Nov-10
Spare Parts	6	Mar-11
Spider-Man: Shattered Dimensions	8.5	Oct-10
Splinterhouse	5	Feb-11
Stacking	8.5	Mar-11
Star Wars: The Force Unleashed II	7.75	Nov-10
Super Meat Boy	9	Dec-10
Tast Drive Unlimited 2	8.5	Mar-11
Tron: Evolution	4.5	Jan-11
Two Worlds II	7.75	Mar-11
Vanquish	7.75	Nov-10
Venetica	5.5	Mar-11
WWE Smackdown vs. Raw 2011	8	Dec-10
You Don't Know Jack	8	Feb-11

<b>WII</b>		
Babysitting Mama	3	Jan-11
Batman: The Brave and the Bold	8.5	Oct-10
Create	5	Jan-11
DJ Hero 2	9.25	Dec-10
Donkey Kong Country Returns	9.5	Dec-10
Epic Mickey	7.75	Jan-11
Flip'n' Twisted World	3.5	Jan-11
Ghost Falcon	4.5	Jan-11
GoldenEye 007	6.5	Dec-10
Gully Party	8	Sep-10
Guitar Hero: Warriors of Rock	8	Nov-10
Kirby's Epic Yarn	9.5	Dec-10

<b>WII</b>		
Legend of the Guardians: The Owls of Ga'Hoole	7.25	Nov-10
Lord of the Rings: Aragorn's Quest, The	5.75	Nov-10
Lost In Shadow	7.5	Feb-11
Mario Sports Mix	4.5	Mar-11
Marvel Super Hero Squad: The Infinity Gauntlet	6.75	Feb-11
Metroid: Other M	6.25	Oct-10
Michael Jackson The Experience	6.5	Jan-11
NSA Jam	8.25	Nov-10
NHL 2K11	6	Oct-10
NHL Slapshot	7	Oct-10
Pac-Man Party	6.75	Dec-10
PaidPark: Pikachu's Adventure	4	Dec-10
Sengoku Basara: Samurai Heroes	6.75	Dec-10
Sonic Colors	7	Jan-11
Tron: Evolution Battle Grids	6	Jan-11
Wii Party	4.5	Nov-10
You Don't Know Jack	8	Feb-11

<b>PC</b>		
Amnesia: The Dark Descent	9.25	Nov-10
Arcania: Gothic 4	6.75	Dec-10
Biojeweled	9	Jan-11
Call of Duty: Black Ops	9	Dec-10
Civilization V	9.75	Nov-10
Create	5	Jan-11
Dead Space 2	9	Feb-11
Divinity II: Flames of Vengeance	7.75	Jan-11

Elemental: War of Magic	6.5	Nov-10
Fallout: New Vegas	8.5	Dec-10
Front Mission Evolved	7.75	Oct-10
James Bond 007: Blood Stone	7.5	Dec-10
John Daly's ProStroke Golf	7.5	Nov-10
Lara Croft and the Guardian of Light	9	Sep-10
Mafia II	9	Oct-10
Medal of Honor R.U.S.E.	7.75	Oct-10
StarCraft II: Wings of Liberty	10	Oct-10
Two Worlds II	7.75	Mar-11

<b>WII</b>		
Dragon Quest XI: Reaons of Revelation	6.5	Mar-11
Final Fantasy: 4 Heroes of Light	6	Nov-10
Ghost Trick: Phantom Detective	6	Feb-11
Kingdom Hearts Re:coded	6.75	Feb-11
Mario vs. Donkey Kong: Mini-Land Mayhem	8.25	Dec-10
Oceanhorn	8.25	Mar-11
Plants vs. Zombies: Garden of Eatin'	6.75	Feb-11
Pokemon Black/White	8.75	Mar-11
Pokemon Ranger: Guardian Signs	7	Oct-10
Professor Layton and the Unwound Future	8.25	Nov-10
Radiant Historia	8.75	Mar-11
Sonic Colors	8.5	Jan-11
Super Scribblenauts	8.75	Nov-10

<b>PSP</b>		
God of War: Ghost of Sparta	9.5	Dec-10
Invizimals	7	Dec-10
Kingdom Hearts: Birth by Sleep	8.5	Oct-10
Lord of Arcana	7	Mar-11
Tactics Ogre: Let Us Cling Together	9	Mar-11
Valkyria Chronicles II	6.5	Sep-10
Ys: The Oath in Fafnir	6.5	Jan-11

## gameinformer

Volume XX • Number 4 • Issue 216

### STAFF

- Publisher**  
Cathy Preston cathy@gameinformer.com
- Editor-in-Chief**  
Andy McManama andy@gameinformer.com
- Executive Editor**  
Andrew Reiner reiner@gameinformer.com
- Senior Editor**  
Matt Hodgson matt@gameinformer.com
- Senior Associate Editors**  
Matthew Kato kato@gameinformer.com  
Adam Biesenzer adam@gameinformer.com  
Joe Juba juba@gameinformer.com  
Matt Miller miller@gameinformer.com
- Content Manager**  
Matt Bertz mbertz@gameinformer.com
- Editor**  
Jeff Cork jeff@gameinformer.com
- Video Editor**  
Ben Hanson bhanson@gameinformer.com
- Associate Editors**  
Ben Reeves ben@gameinformer.com  
Bryan Vore bryan@gameinformer.com  
Meagan Marie meagan@gameinformer.com  
Jeff Marchisano jeffm@gameinformer.com  
Tim Turi tim@gameinformer.com  
Anselmo Gonzalez anselmo@gameinformer.com  
Philip Kollar phil@gameinformer.com  
Das Ryzkier dan@gameinformer.com

- Art Director**  
Thomas Bustin tom@gameinformer.com
- Creative Director**  
Jeff Abarick jeff@gameinformer.com
- Production Director**  
Curtis Feng curtis@gameinformer.com
- Software Engineer**  
Sean Lowery sean@gameinformer.com
- Circulation Services**  
Ted Katzung ted@gameinformer.com
- Information Systems Manager**  
Paul Hodgeth paul@gameinformer.com

### ADVERTISING SALES

- Associate Publisher**  
Rob Borm rob@gameinformer.com
- West Coast Advertising Sales Director**  
Damon Watson damon@gameinformer.com
- East Coast Advertising Sales Director**  
Suzanne Lang suzanne@gameinformer.com
- Advertising Coordinator and Online Sales**  
Amy Arnold amy@gameinformer.com
- West Coast Advertising Associate**  
Janey Stringer janey@gameinformer.com
- Marketing Coordinator**  
Rachel Himerforh rachel@gameinformer.com  
Mark Burger mark@gameinformer.com

### CUSTOMER SERVICE

For renewal, address change and Edge card details:  
Visit [www.gameinformer.com](http://www.gameinformer.com)  
Email [customerservice@gameinformer.com](mailto:customerservice@gameinformer.com)  
or send correspondence to:  
724 North First St., 3rd Floor  
Minneapolis, MN 55401 • Attn: CIS Dept

For subscription inquiry ONLY:  
1 (866) 844-GAME (4263)

Manufactured and printed in the United States of America. The Editor welcomes company product information for all video games. Such materials should be addressed to: Editor, Game Informer Magazine, 724 North First St., 4th Floor, Minneapolis, MN 55401. Unsolicited manuscripts cannot be returned or acknowledged. Entries contents copyright ©2011 Game Informer Magazine. All rights reserved. reproduction in whole or in part without permission is prohibited. Game Informer is a trademark of GameStop, Inc. Products named in these pages are trade names, or trademarks, of their respective companies. PUBLISHER LIABILITY FOR ERRORS The publisher shall not be liable for slight changes or typographical errors that do not lessen the value of an advertisement. The publisher's liability for other errors or omissions in connection with an advertisement is limited to republishing of the advertisement in any subsequent issue on the refund of any amount paid for the advertisement. INDUSTRY PRACTICES The advertiser and/or Advertising Agency agrees to defend and indemnify the publisher against any and all liability, loss, or expense arising from claims of libel, unfair competition, unfair trade practices, infringement of trademarks, copyrights, trade names, patents, or proprietary rights or violation of rights of privacy, resulting from the publication of the Advertiser's statement.



Member Audit Bureau of Circulations

In memory of Paul Anderson

## Celebrating an RPG Godfather's 30th Birthday

by Phil Kollar

**N**ihon Falcom Corporation is hardly one of the most popular or recognizable developers in the industry, but it has built a reputation for crafting beloved role-playing cult classics. I spoke with the company's current president, Toshihiro Kondo, to find out about Falcom's past and future.

Falcom was founded in March 1981 and quickly became known as the premiere PC game developer in Japan, working on titles ranging across multiple genres, such as Galactic Wars and Horror House. In 1984, they released the first game in a series and genre that would help define the company: *Dragon Slayer*.

This top-down action RPG was one of the first games to introduce elements that would become standard in RPGs of the future, such as loot collecting and puzzle-solving in-between combat.

"For everyone who's creating games right now, [the early *Dragon Slayer* games] are kind of like a textbook," Kondo says. "It's like the definition of an RPG. Everything that needs to be in a Japanese RPG is in [*Dragon Slayer*]. It was carefully created down to the smallest details, like the timing of treasure boxes appearing in the game."

Though the original *Dragon Slayer* never made it to the U.S., the 1985 sequel, subtitled *Xanadu*, received a North American side story on the NES. Titled *Faxanadu* and developed by Hudson Soft, this spin-off didn't stick very closely to *Dragon Slayer II*, but it still introduced many gamers to Falcom's first hit series even if they didn't realize it at the time. Later *Dragon Slayer* titles such as *Legacy of the Wizard* and *Sorcerian* made their way to North America in more authentic forms.

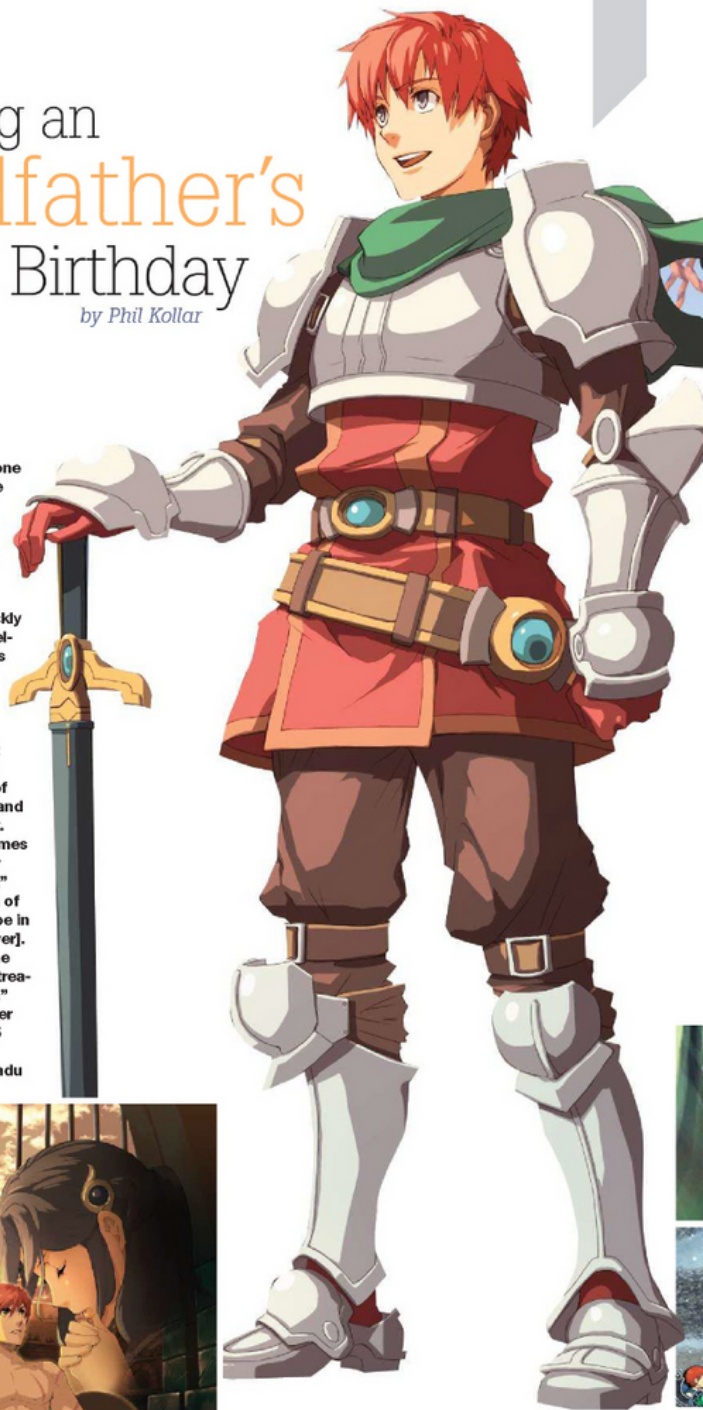

## The Legacy Of Ys Begins

In 1987 Falcom created a game that quickly became the company's biggest franchise: Ys (pronounced "Ees"). Another top-down game, Ys became one of the best-known action-RPG series in Japan. In North America, Ys was released for the Sega Master System, but its unique combat — which required protagonist Adol Christin to run headlong into enemies — did not catch on.

The first two Ys games told a single story but were separated by a year between releases. Until 2008, the second Ys title was not available in North America except as part of the 1990 compilation Ys Books I and II, which appeared on the relatively unpopular TurboGrafx-CD. A third stand-alone installment, subtitled Wanderers from Ys, followed in 1989.

Though Ys II made it to the U.S. for the TurboGrafx-CD, SNES, and Genesis, it was the last Ys title to reach our shores until 2005's Ys VI. It had a hard time gaining acceptance stateside, but the series developed a passionate following in Japan.

In 1989, Falcom started preparing the sixth game in the Dragon Slayer series. Subtitled "The Legend of Heroes," this game eventually spun off into its own long-running franchise that is still being worked on today. Until 2004's PSP remake of Legend of Heroes IV, the TurboGrafx-16 version of Dragon Slayer VI was the only Legend of Heroes game to be released in North America.

"Back then, Falcom was known for having beautiful graphics," Kondo recalls, "but the president thought that since everyone else was becoming better in that department, we needed something else to shine in the game, to give it its own identity. We decided to put our energy into the story. For a story, you just need one scenario writer, but you need a lot more people for better graphics."



Clockwise from upper left: The Legend of Heroes: Trails in the Sky, Ys Seven, Ys I & II Chronicles, and Ys: The Oath in Felghana

## Branching Out

While Dragon Slayer and Ys continued with new releases, Falcom celebrated their 10-year anniversary in 1991 by creating a fan-favorite side project: the top-down dungeon crawler Branchish.

"It was an innovative game," Kondo says. "You were able to play the game with only a mouse. A mouse was a rare product back then. The president of Koel loves this series, too. Back in the day, the vice-president of Koel came up to the president of Falcom because the president of Koel was too into the game and wouldn't get any work done. So we got complained about, but then Koel ended up releasing the Super Famicom

version of Branchish." That Super Famicom port also made its way to the SNES in North America.

As 1994 rolled around, Toshihiro Kondo was working through college, studying the Internet. In the midst of his schoolwork, he fell in love with The Legend of Heroes III: Prophecy of the Moonlight Witch.

"It's the game that made me interested in Falcom," Kondo remembers. "The game has a huge scenario. Usually when the scenario is too big, you don't want to read through it, but Falcom made a

story that players wanted to read." Sadly, when Prophecy of the Moonlight Witch finally made its way to North America via a Namco Bandai PSP port in 2006, fans who had eagerly awaited the game discovered a terrible translation that robbed it of the power that drew Kondo to the company.

Four years after the Legend of Heroes III's release, in 1998, Kondo had a chance meeting with the founder of Falcom. He spun this opportunity into a job working as a server technician.

"When I first joined the company, I was working on maintaining the servers, but by my second year with Falcom, I was mostly working on development," he recalls. "I started managing projects and getting involved in game design and maintaining schedules. By the end, I was involved in the whole process of development. From there, I started managing the whole company. Three years ago, I became the president of the company."

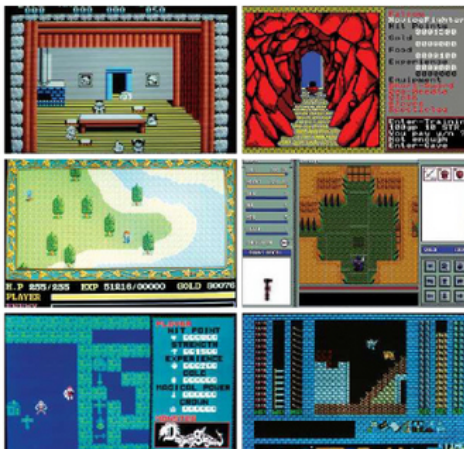

Clockwise from upper left: Dragon Slayer IV, Dragon Slayer II: Xanadu, Branchish, Dragon Slayer III, Dragon Slayer, and Ys I



## A Calculated Gamble

In 2006, just before Kondo took over as president, Falcom made a sudden and surprising development shift. Where they had previously created games almost exclusively for PC, they realized the market was starting to dry up and started looking toward other platforms.

"Back when I was still on the development staff, the founder of Falcom told us, 'Don't think it's going to be like this forever. We're not going to be able to keep releasing our games on PC forever,'" Kondo explains.

Despite skepticism from the staff, the president's warning proved true. A shrinking market for PC titles in Japan made it increasingly difficult for Falcom to break even on its games. Clearly, they had to make a change.

After analyzing all of the systems currently on the market, the PSP became the obvious choice. "It might be different in the West, but in Japan, handheld games are becoming a mainstream thing," Kondo says. "I feel that [hardcore] gamers have settled into the PSP market. More of a general market is playing Wii and DS. Of course, I'd like for the general market to play our games too, but I acknowledge that hardcore gamers like our style of games more. That's why we like the PSP market."

## Looking To The Future

With a sea change in the handheld market on the horizon with the Nintendo 3DS and Sony NPG, Kondo offered some thoughts on where the company is headed in the future.

"I feel like the NPG is a very firm innovation from the PSP," he says. "The touch panels and the gyroscopic sensors look very promising. We're planning to release a lot of titles on the NPG. I have hopes for this platform to set fire to the game market in Japan again."

Falcom also has plans to branch out. "We're already creating titles on a different platform," Kondo hints, "but I can't tell you which one at this point." Despite being coy, Kondo admits that Falcom is interested in working in the downloadable space, which is generally underserved in the RPG genre. Kondo feels that this format could offer new opportunities for how its games are structured.

"Our general way of thinking about RPG games is that we spend two years creating the game and then release it as a packaged title; that's the completion of the game. With NPG and Xbox Live Arcade and PlayStation Network, we've started to think that we might be able to release RPGs in a different way," Kondo reveals. "Maybe we could release one chapter at a time as downloadable content. We're considering it heavily right now." ♦

# Things You Didn't Know About...



**RANDY PITCHFORD**

After one of the longest development cycles in gaming history, the king is finally set to make his return to the limelight in Duke Nukem Forever, thanks in large part to Gearbox Software. Leading the cause is Gearbox president Randy Pitchford, who got his start at 3D Realms and says he owes Duke his career. Read on to learn more about one of the industry's biggest innovators, an ex-magician who always has a few tricks up his sleeve.

**+ Early career moves**

Before I decided to change my path and become a professional game maker, I was studying law at UCLA and working as a magician to pay my way through school. I worked at the Magic Castle in Hollywood. Entertainment's fun. I like entertaining people.

**+ Best trick**

I love close-up magic. I like using simple objects like coins and cards, and just doing stuff that's impossible right in front of people's eyes.

**+ Bringing magic to games**

It's a very similar craft. We're creating an illusion of something that isn't real, whether it's a virtual world or setting up a line of logic, and we use a lot of smoke and mirrors in games to get you immersed in something that doesn't exist. Being able to get into the mind of the audience and understand how they're parsing what's happening and leading them to that "aha!" moment, or that surprise or that challenge that feels gratifying to overcome, a lot of the same thinking and same skills apply it turns out.

**+ Best and worst projects**

It turns out my favorite game that I've worked on always tends to be one of our current projects in development. It's not announced yet, so I can't talk about it here. My least favorite was James Bond 007: Nightfire – not because I didn't enjoy contributing to the James Bond canon, but because the business deal taught me some things. We sort of got caught in a bait-and-switch there, and the game became a work-for-hire effort where Gearbox wasn't able to apply its value in the direction of the game as creative drivers. As a consequence, the best elements of the game are the multiplayer modes, and the later levels were where we were afforded the most creative freedom. It was a valuable lesson – don't get involved unless we have enough creative license to push for quality.

**+ Games he wants to pursue**

For some time I've believed that there is opportunity with a quality heist game. Awhile back I had licensed the film *Heat* to use for a video game, but other priorities prevented us from being able to give it the correct attention. I wish someone would make a great heist game someday – maybe it will be us.

**+ Games he thought of first**

A friend of mine and I designed Grand Theft Auto, name and all, in 1990. Our version was open world and story driven, but included a core mechanic that was closer to the theme that was about delivering the stolen cars to buyers or dismantling them in chop shops to sell the untraceable components. While I was creating games as an amateur at the time, it wasn't my sole focus. I wouldn't enter the industry for another several years and my focus became FPS games.

**+ Games he chooses to forget**

All games contain lessons, and the sum of every experience I've had gaming contributes to my understanding of what works and what doesn't. If I must be specific, back on the Atari 2600 there were piles and piles of shovelware that contributed to the video game industry crash in the '80s – we could've done without those games.

**+ Favorite pastimes**

Video games are my passion, my hobby, and my lifestyle. When I'm not at the studio creating games, I'm usually playing them. I do have other hobbies, including piano, guitar, painting and sculpture, film and television, dining and travel, but I tend to prioritize video games above all other forms of entertainment. Video games are one of the only forms of entertainment that exist to consume my time while amusing me, but also leave me with a feeling of accomplishment and gratification for the time I've given them. This property, I think, is why video games are such a compelling form of entertainment for such a large and growing number of people.

**+ Motivations**

I still haven't figured it out yet. I do not know why, and I've contemplated this a great deal, but there is something inside me that compels me to need to entertain people. When I was younger, I would do this more personally by being a clown. As I've matured, I've directed this toward the entertainment I create and enable, and by honing in on the metrics I use to judge myself as an entertainer. How many people can I reach and to what extent can I gratify those people with what I have offered them?

MORE  
OPTIONS

MORE  
REWARDS

# SUBSCRIBE TO gameinformer AND GO PRO WITH GameStop

## 12 ISSUES ONLY \$14<sup>99</sup>



DIGITAL

YOUR  
CHOICE

PRINT



**MORE OPTIONS** to experience the world's #1 video game magazine.

Digital Delivers Dimension

- ▶ Explore embedded video and interactive links.
- ▶ Immediately access up to a year's worth of back issues online.
- ▶ Key word search any single magazine issue or your personal Game Informer online library.
- ▶ Choose Digital and get your monthly issue straight to your email inbox.

**MORE REWARDS**

With GameStop® PowerUp Rewards Pro™, your subscription allows you to get more than ever before.

- ▶ 10% off pre-owned games and accessories
- ▶ 10% bonus trade-in credit
- ▶ 10% point bonus on all purchases
- ▶ Buy 2, Get 1 free welcome gift on pre-owned games
- ▶ 250-point Pro enrollment bonus
- ▶ Double Epic Reward Giveaway™ entries per purchase or trade\*
- ▶ Exclusive access to news, offers and events
- ▶ Points toward rewards with every dollar spent

\*Limited to one transaction per day.



▶ Go to GameStop ▶ Subscribe ▶ Go Pro with GameStop® PowerUp Rewards Pro™ and Get More



US \$5.99 | EUR €5.99 | UK £3.99



Issue 216 • April 2011

[www.gameinformer.com](http://www.gameinformer.com)