

APRIL 1983  
75p

# COMPUTER & VIDEO GAMES

Relive  
The Battle of  
Trafalgar

Could you be our  
1983 ARCADE  
CHAMP?

Games for the Vic  
Spectrum · Atari · Dragon · ZX81 and many more

# SPECTRAVISION™

## For the ATARI® Video Game System



**A NEW CHALLENGE** – To test your skills  
**MORE FUN** – For all the family

The Spectravision range of video games for the Atari Video Game System presents realistic sound effects, advanced colour graphics and more action at prices the whole family can afford.

**At your local video games stockist NOW!**

Please send me your fully illustrated games leaflet. C1

Name \_\_\_\_\_

Address \_\_\_\_\_

\_\_\_\_\_

\_\_\_\_\_

**VPD Limited (Video Games Division)**  
GEC Estate, East Lane, Wembley, Middlesex HA9 7FF.

## News & Reviews

- GAMES NEWS** 16  
Return to the land of Zork with a brand new adventure, and we check out games packs for the Sharp MZ-80K.
- VIDEO SCREENS** 20  
TV games centre that provides its own screen, discover the Vectrex. And Matel starts to support the Atari!
- ARCADE ACTION** 30  
Meet O'bert, the 'cute' character, that US video gamers took to their hearts. Plus tips on Tron.
- REVIEWS** 88  
Galaxians take flight on the Atari, and there's a host of horrors in the Spectrum 3D Tunnel. Find out how they fare.
- NEXT MONTH** 5  
Read all about our involvement in a brand new BBC TV series

## Listings

- TRAFALGAR** 32  
Relive the era when mastery of the seas meant mastery of the world. Opposing admirals of the fleet take to the high seas, trying to outwit one-another and the elements as they manoeuvre their ships into position. All hands to the ZX81.
- SKYSCRAPER** 35  
Finding a place to park your jet in a city of skyscrapers gets more difficult every day, the car parks are all full, there's double yellow lines everywhere, and those dreadful traffic wardens... oh, and there's all those buildings too. Come down to earth with a bang on your Dragon.
- STASTEROIDS** 40  
Out in deep space in deep trouble! Unless you can find your way through the dangerous meteoroid field to the refuelling station. Space-age action on your Spectrum.
- DRAGON RUN** 44  
Once upon a time in a land far away there was a dragon-hunter — and lots of dragons. Fiery-fun for Atari 400/800 owners with a taste for danger.
- ELECTION** 48  
So you think you'd make a great MP eh? Well, just try convincing the voters. All the action of a general election in this party political program on behalf of Pet owners.
- BLOCKBUSTER** 56  
Trapped in a deadly maze of giant blocks — can you blast your way out, or will you be doomed to roam the maze forever with only your Atom for company?
- PACMAN** 58  
Yes, it's that lovable little munchy-man again! This time you can enjoy a snack between meals on your BBC model A. But watch out for those ghosts!
- SIMON** 62  
Follow the leader in this version of that popular electronic game written especially for the Sharp MZ-80K. Can you beat the computer?
- LOGGER** 64  
I'm a lumberjack and I'm not OK... that pesky bird keeps on stealing my axe. Get those feathers flying on your stripped-pine Vic-20.

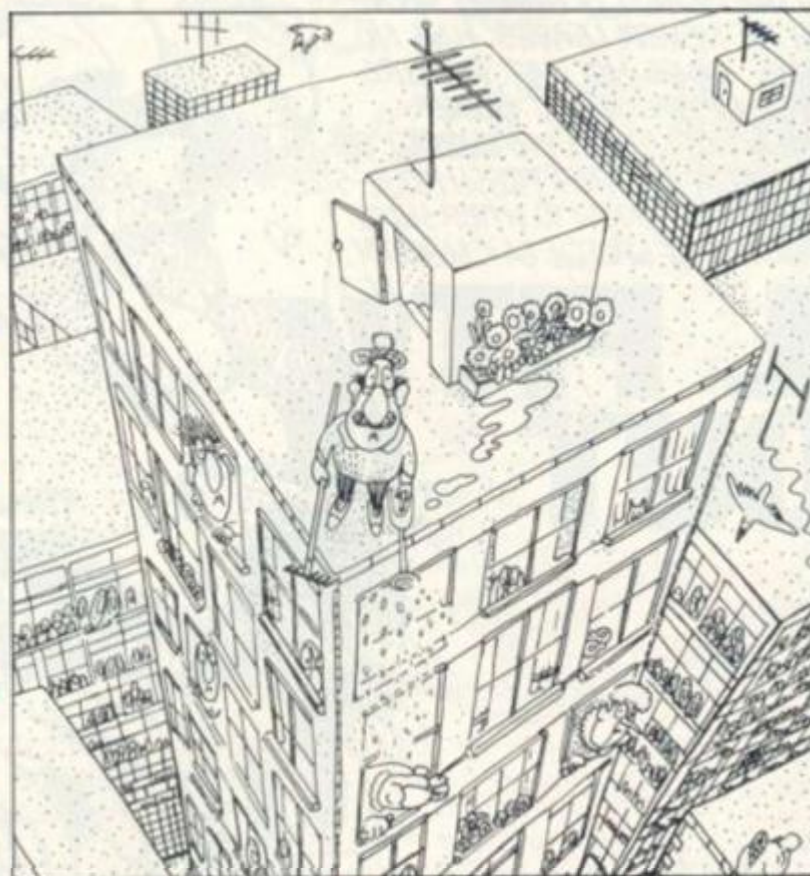

## Avast landlubbers!

Harken back to the days when Horatio Nelson ruled the Seven Seas with a rod of iron and 15lb of cannonball.

Our Trafalgar game reconstructs the thrills of the great sea battles when Men O'War clashed with countries and kingdoms teetering on the outcome.

Our ZX81 game gives two rival admirals fleets to command as they battle one another, plus the elements in this thrilling game of strategy.

Election transports you into Pet politics with the hard job of vote-winning to put your party into power at the next general election. And with the current state of politics it could be a test run for the real thing in a couple of month's time.

Logger offers a different look at the Donkey Kong game featuring a lumberjack and a far from helpful bird. It runs on the Vic-20 computer.

Then there's space drama, dragons and a deadly maze. The fun starts here!

## Features

- MAILBAG** 7  
The Seventh Empire strikes back. Plus more of your news, views and program tips.
- COMPETITION** 10  
Alcatraz — a pinball it could be difficult to get away from designed by our competition winner!
- CHESS** 25  
Knight v. Rook endings. Max Bramer makes every move a winner.
- BUGS** 28  
The Bugs' programmer buys a new micro. But what about the Bugs!
- SOFTWARE FORM** 68  
Helping you to help us produce better games.
- SEVENTH EMPIRE** 70  
Start building a score worthy of a Colecovision. How did you fare?
- GRAPHICS** 72  
Garry Marshall delves into 3D.
- MACHINE CODE** 74  
Ted Ball on comparison instructions.
- PROJECTS** 80  
Keith Mott's latest ideas.
- ADVENTURE** 83  
Keith Campbell goes on a quest.
- WARPATH** 84  
Ron Potkin is still on the trail of a wild west wargame.

Editor Terry Pratt, Staff Writer Eugene Lacey, Editorial/Publishing Asst. Susan Cameron, Art editor Linda Freeman, Production editor Tim Metcalfe,

Advertisement manager Rita Lewis, Advertising executives John Phillips, Louise Matthews Advertisement assistant Louise Flockhart, Publisher Tom Mooney,

Editorial and advertisement offices: Durrant House, 8 Herbal Hill, London EC1R 5JR; Telephone Editorial 01-278 6596, Advertising 01-278 6562

**COMPUTER AND VIDEO GAMES POSTAL SUBSCRIPTION SERVICE.** By using the special Postal Subscription Service, copies of COMPUTER AND VIDEO GAMES can be mailed direct from our offices each month to any address throughout the world. All subscription applications should be sent for processing to COMPUTER AND VIDEO GAMES (Subscription Department), Competition House, Farmdon Road, Market Harborough, Leicestershire. All orders should include the appropriate remittance made payable to COMPUTER AND VIDEO GAMES. Annual subscription rates (12 issues): UK and Eire £10.00 Overseas surface mail £12.00 Airmail Europe £20.00 Additional service information including individual overseas airmail rates available upon request. Circulation Department: EMAP National Publications. Published and distributed by EMAP National Publications Ltd. Printed by Eden Fisher (Southend) Limited.

© Computer & Video Games Limited ISSN 0261 3697.

Cover: J. M. W. Turner (The Tate Gallery) London. Next issue: April 1983

# Chromasonic Hall of Fame No.4

THE 'MACHINE CODE PROGRAMMER'. THIS SPECIES OF COMPUTER BUFF IS DIFFICULT TO SPOT, AS NORMAL HABITAT IS ILL-LIT GARRET ABOVE CHIPPY, WHICH HE NEVER LEAVES. HAS NO CONCEPT OF TIME. DOES NOT EAT. PICTURE SHOWS EXAMPLE OF SPECIES AT SLEEP. BODILY MOVEMENT CONFINED TO BELOW THE WRIST. OCCASIONALLY IGNITES FRESH KING-SIZE. THIS SPECIES HAS BEEN KNOWN TO UTTER SHORT MEANINGLESS PHRASES OF SPEECH. 64K MEMORY.

# WE'LL FIT YOU OUT



AT CHROMASONIC, WE HAVE EXPERIENCE IN GENTLY SUGGESTING THE RIGHT EQUIPMENT, AND TENDERLY ADVISING EVEN THE MOST FRAGILE OF BREEDS ON THE SYSTEM THAT WILL SUIT, SO IF THE LIGHT IS NOT TOO BRIGHT FOR YOUR DELICATE RETINA, PLEASE CALL ON US, WE CAN FIT YOU OUT, AND PUT YOU BACK ON THE RIGHT BUS HOME. AMONG STOCKED ITEMS WE HAVE.....

**VIC 20 NEW LOW PRICE £129**

**VIC PRINTER £212.00**

80 Characters per line. 30 Characters per sec... Tractor Feed Dot matrix printer.



**VIC SINGLE FLOPPY DISK OUR PRICE £286**

174K Byte Storage Direct interface to VIC Compatibility with



**VIC CASSETTE DECK £39.00**

Free cassette with 6 programs supplied

**DRAGON 32**

- \* 9 Colours
- \* 32K RAM memory as standard, expandable to 64K
- \* Extended Microsoft colour basic as standard
- \* Typewriter Keyboard
- \* 6809E CPU
- \* Advance sound feature
- \* 32 Columns x 16 Lines

OUR PRICE £189

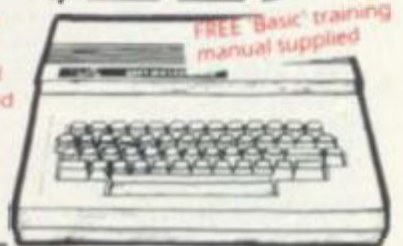

FREE 'Basic' training manual supplied

The 64 from

**commodore**

- 64K RAM
- 16-colour display
- music synthesiser
- 3-D effect

OUR PRICE **£343**

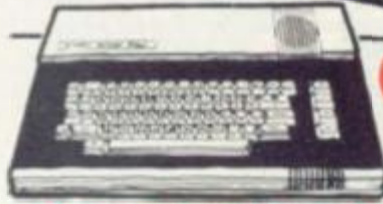

**COLOUR GENIE**

**EG 2000 PAL VERSION**

\* Typewriter Keyboard

- \* Serial and Parallel I/O Ports
- \* CPU: Z80A/2.2 MHz
- \* 3 Sound Channels
- \* 40 Columns x 24 Lines
- \* 8 colours
- \* Extended Microsoft colour basic standard
- \* 16K RAM standard expandable to 32K

OUR PRICE **£199**

**BBG MODEL A & B**



Authorised Dealer

Full Technical Support and After-Sales Service  
Large list of Software and Peripherals

- ACCESSORIES FOR YOUR VIC20**
- Super Expander High Resolution Cartridge **£31.00**
  - Programmers Aid Cartridge **£28.00**
  - Machine code Monitor Cartridge **£28.00**
  - 16K RAM Cartridge **£39.00**
  - 16K RAM Cartridge **£59.00**

TELEPHONE

**01-2639493/5**

Chromasonic Hall of Fame Album send 75p for your collector's Album. Send the cuttings out the cartoon on 4x6s or, one in a series of 50. We will send you the cartoon of your choice with every order, to help you build up this exclusive 1985 collection. Price for 1st full album presented to us!!

# CHROMASONIC PERSONAL COMPUTERS

48 JUNCTION RD, ARCHWAY, LONDON N19 5RD Telex 22568



I am interested in a home computer. Please send me further details

- VIC 20
- DRAGON 32
- COLOUR GENIE
- ADD-ONS
- SOFTWARE

TERMS OF BUSINESS: All prices incl. 15% VAT. Delivery charged at Cost. Prices valid for cover date of this mag. Access and Bartsyard orders welcome.



Please send me 'Hall of Fame Album'. I enclose 75p.

NAME: .....

ADDRESS: .....

CV4

## BEEB GETS THE GAMING BUG

Computer gaming is making its first impression on television this month in a Saturday morning programme which is taking over the Saturday Super Store slot.

Get Set (for Summer) will be featuring computer games throughout its 16 week series which runs up until the school summer holidays.

The programme aims to give practical ideas on new hobbies, sports and other activities to try out or take up during the summer holiday. And series producer Tony Harrison is a home computer owner keen to demonstrate the new world which a microcomputer can open up.

The first programme in the series goes out on April 2nd and features not only home computers but also TV games centres and arcade machines.

And the series is also unique in having a microcomputer-controlled system of "cue-ing" programme presenters Mark Curry and newcomer Deborah Appleby. This system runs on a BBC Microcomputer and was written by the producer's son Daniel.

The presenters will be able to look up during the programme to check on how much time is left on any particular interview or demonstration. Events during the programme can be reshuffled on the screen to change the order of programme features or fit in new items.

Computer & Video Games will be helping out during the series and the slot on Saturday April 16th will be of particular interest to all computer games programmers.

As home computing comes of age throughout Britain it is ironic to think that 1983 may go down as the Year of the Home Video Game.

Our Video Screens section has already been full of the rich promise of new games and new machines which should be with us before 1983 ends.

The Colecovision launch should (lawsuits permitting) provide the industry with some much-needed

# This here's my newsagent



Me 'n my newsagent are real close. His name's Bill or Fred or something... Anyway we got an arrangement. Every month, you know what he does? He looks out my copy of *Computer & Video Games* and keeps it, just for me.

So none of the other punks on the street can get hold of my copy. And that's important to me. Mebbe it's important to you too. So go n' see your newsagent with that coupon below all filled out. If he's like Harry here, you're gonna like him.

To my newsagent: Please deliver/reserve me a copy of *Computer and Video Games* every month. Price 75p.

Name .....

Address .....

compatibility when it adds the Atari and Intellivision expansion modules.

Intellivision's manufacturers, Mattel, are opening up the software market by bringing out their top games in Atari format, on the M Network series.

In our May issue, Eugene Lacey takes a look at the new way to cut the cost of home video gaming — by renting the cartridges rather than paying around £20 plus to find out you've tired of the game after the first couple of days.

Several companies have sprung up offering cartridges for hire and the latest move is for public libraries to open up a software section too.

Arcade games players will have another chance to enter our Best Arcade Player Championship and we'll be printing up some scores to aim at on different machines in our record breakers section.

But although the records give some idea of what is possible, re-

member that they still have to reproduce those scores and get them signed by the arcade owner in the next three months.

**NEXT MONTH** Mad Max is the most interesting listing we've had for some time. Our reviewer rates it as the best driving game he has ever come across on the Sharp and the course certainly looks to include some fascinating features. So rev up and get ready to drive off into the future with Mad Max in May.

Add a new dimension to gobbling games with the Ghost's Revenge by Gareth Jones. This is a novel two-player extravaganza for the Dragon 32 which could spell the end of Pacmen as we know them!

One player tries to munch his way out of trouble. the other takes control of the ghostly pursuers.

Then there's Tank Battle for the BBC B and an arcade-style attraction called Grow-Worm wriggling its way out of the Atari 400/800.

No.1 Best Sellers for Your Spectrum!\*

# HOBBIT

and

# PENETRATOR

"A  
Lot of Fun"  
Computing  
Today

STATE  
OF THE  
ART GAME

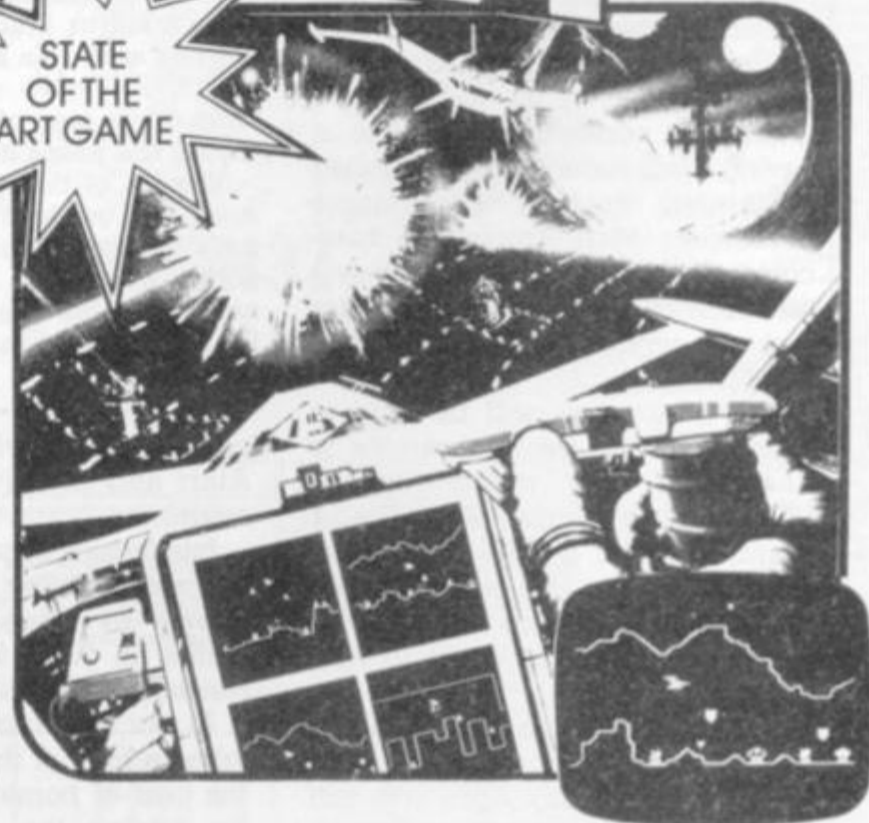

### VISIT MIDDLE EARTH

Experience the fantasy of J. R. Tolkien's "HOBBIT" on your 48K Spectrum. Danger, adventure and excitement are all part of it in words and graphics, but it is you who must solve the problems. Special features never seen before. THE HOBBIT is the program everyone is talking about. £14.95.

### CAN YOU SURVIVE PENETRATOR?

PENETRATOR is the most amazing and sophisticated arcade game yet devised for the 48K Spectrum. Features include training mode, unique customizing, superior graphics, excellent sound and more! £6.95.

**MELBOURNE HOUSE PUBLISHERS** Orders to: 131 Trafalgar Road, Greenwich, London SE10

Correspondence to: Glebe Cottage, Station Road, Cheddington, Leighton Buzzard, BEDS LU7 7NA. Trade enquiries welcome.

Please send me your free catalogue.

Please send me:

**SPECTRUM Books**  
 Understanding Your Spectrum £7.95  
 Spectrum Machine Language For The Absolute Beginner £6.95  
 Over The Spectrum £6.95  
 The Complete Spectrum ROM Disassembly £9.95  
 Spectrum Hardware Manual £5.95

**16K SPECTRUM Cassettes**  
 Over The Spectrum No. 1 £5.95  
 Over The Spectrum No. 2 £5.95  
 Over The Spectrum No. 3 £5.95  
 Programs from Spectrum Machine Language Book £5.95

**48K SPECTRUM**  
 Penetrator £6.95  
 The Hobbit £14.95

All Melbourne House cassette software is unconditionally guaranteed against malfunction. Access orders can be telephoned through on our 24-hour ansafone (01) 858 7397.

Please add 80p for post and pack £ .80

TOTAL £ \_\_\_\_\_

I enclose my cheque/money order for £ \_\_\_\_\_

Please debit my Access card No. \_\_\_\_\_ Expiry date \_\_\_\_\_ Signature \_\_\_\_\_

Name \_\_\_\_\_ Address \_\_\_\_\_

Postcode \_\_\_\_\_ **CVG4**

**MELBOURNE HOUSE PUBLISHERS**



\*No. 1 and 2 best selling Spectrum programs four weeks running in Personal Computing Weekly charts.



Please drop us a line at: Computer and Video Games, EMAP, Durrant House, 8 Herbal Hill, London EC1R 5JB.

## TRADE WITH ENEMIES

Dear Sir,  
If at the start of a turn in Seventh Empire you are in an empire at war with a neighbour can you Move to a neutral neighbour and then Trade with the previous enemy in your second movement phase?

Roy Rogers,  
Crockenhill,  
Kent.

**Editor's reply:** No. As you still are considered to belong to the empire whose star you began the turn at, such a Trade would be illegal. But keep trying Roy!

## PLUNDERING FOR PROFIT

Dear Sir,  
I have calculated my score to be just outside the Top 10 Seventh Empire commanders you published last issue and I'm kicking myself for not following Mr Tactico's example and Plundering rather than Cargo-ing.

My two Cargo moves were both robbed of profit by greedy pirates and I wonder if there's any profit to be had in ever travelling by Gateway except on a Plunder mission. Is this a valid flaw in Seventh Empire? Please comment.

Still, I can congratulate myself on some good trading and I am enjoying a marvellous sense of anticipation awaiting next month's results.

D. Andrews,  
Knightsfield,  
Welwyn Garden City.

**Editor's reply:** Seventh Empire tactics will evolve over the next few months Mr Andrews and players will change from Cargo to Plundering, as I suspect that you have done. And when so many people are Plundering Gateway routes,

there will be a reluctance to Cargo and the pirates profits will plummet.

In our first go, Cargo-shippers actually fared better than the Plunderers and many of our top 10 accumulated profits on a number of Cargoes.

Much of the excitement of The Seventh Empire will be in seeing how the winners have applied their tactical thinking to the number of players in the game. Very soon Attacks may prove a big profit booster as players learn to spot isolated star systems vulnerable to a large influx of Attackers.



## PROBLEMS IN THE EMPIRE

Dear Sir,  
Several problems have arisen with the Seventh Empire and I feel they can be best answered in writing.

In working out profit through Trade, do you use: the issue with the order sheet you send in, the following issue or both issues?

To work out Plunder and Cargo profit you need to know the number of fleets using this route.

How do you discover this?

How do you find out the Battle Bonus?

J. A. Howes,  
South Croft,  
St Johns,  
Worcester.

**Editor's reply:** Trade profit is worked out by comparing the trade index of each star in the issue following the one you sent your orders in for. So the March move is calculated by the figures on April's Galactic Map.

Plunder and Cargo is worked out by checking the Gateway Route Table. Find the star you moved from in the vertical column and move across until you reach the star you moved to horizontally. The figure there gives profits for either merchant or pirate. Battle Bonuses are given in the Battle Reports section.

## WHAT'S IN A PEEK?

Dear Sir,  
I am a beginner in the world of computers. I would like to know the equivalent of (PEEK 16398+PEEK 16399) on the BBC machine, it is in the Mole program (Jan 1982) for the ZX81).

What are graphic characters? Has the BBC machine any?

Mr S. Alg,  
Fulham,  
London.

**Editor's reply:** PEEK 16398+256\*PEEK 16399 in ZX81 Basic gives you the address of the PRINT position in the display file. This is not necessary on the BBC m/c as it has a memory mapped screen. So . . . it is not possible to easily translate this to BBC Basic.

The BBC has 32 user defined graphics characters. Again, read page 170 of the manual for a full explanation of how to use the VDU23 command. Needless to say, it is non-standard!

## STAR WARS HIT HOME

Dear Sir,  
If a Seventh Empire fleet Moves or Trades between two friendly stars on its first movement phase, can it Move or Trade with a star at war with the star it has arrived at in the second movement phase?

Ron Murch,  
Downs Barn,  
Milton Keynes.

**Editor's reply:** In neither movement phase is a fleet allowed to Trade or Move to a star at war with any star it has left or visited during that turn.

## DON'T QUIBBLE OVER BBC

Dear Sir,  
I write in reply to a letter by Alan McAuley which appeared in your December issue.

I would like to know to what application a ZX Spectrum can be put that a BBC machine cannot cope with.

I admit that the model A is expensive, but the BBC machine was designed with expansions in mind. This means that it has a very wide range of practical applications.

I personally have a BBC model B and although I haven't seen the Spectrum, I have seen the ZX81 which doesn't even come close.

In any case to say that Sinclair machines are the best micros on the market is ludicrous, they are the cheapest, and from what I have seen you get what you pay for.

This is not a quibble concerning the Spectrum and BBC machines. I know which is best and this is reflected in the machine I have bought.  
David Hetherington,  
London.

# ANIROG

## KRAZY KONG . . .



An expanded screen presentation with rolling barrels, hammer, fireballs, lifts, handbags and umbrellas as you try to rescue the Damsel Kong has abducted. Spectacular collapse of Kong's lair in fourth screen. Uses all 21K of your expanded Vic for this 100% m/c thriller. Complete with high score table. K.B./J.S. 16K £7.90

### XENO II

Gorf style 100% m/c space adventure with four action packed games. All games use expanded screens and large graphics. Fast moving Robotron. Ultra fast Space Invaders give you the most spectacular Vic 20 game yet. J.S. 16K £7.90

### ZOK'S KINGDOM

Dare you enter Zok's castle, a distant relative of Dracula. A multi-screen graphical adventure to test agility of mind and action. K.B. 16K £6.00

### PHARAOH'S TOMB

A multi screen graphical adventure to test your skills. Can you avoid the traps set by the Ancient Egyptians and enter the magic triangle. K.B. 16K £6.00

### DRACULA

Find Dracula before he rises and drive a stake through his heart in this multi-screen graphical adventure. K.B. 3K £6.00

## FOR THE UNEXPANDED VIC 20 . . . £6.00

### FROGRUN

All m/c game with brilliant graphics and sound effects with features like busy highway, snakes, crocodiles and lady frogs. K.B./J.S.

### CRAWLER

All m/c version of Centipede. Homing spider, mushroom laying flea and multi-direction travel makes this game fast and furious. J.S.

### CAVERN FIGHTER

100% m/c version of Scramble. Four sectors with missile launchers, ramming ships, fuel dumps and fireballs. K.B./J.S.

### SEVEN PROGS (Vol 1)

Hi-res games for the whole family. Othello, Bomber, Slalom, Bounce Out, Lunar Docker, Memory and Snake. K.B.

### SEVEN PROGS (Vol 2)

Dare Devil, Goblin's Gold, Ghosts, Grand Prix, Breakout, Cobra and Minefield. K.B.

### TINY TOTS SEVEN

Super Snap, Simon, O's and X's, Bomber, Word Jumble, Duch Shoot and Mad Drivers. K.B.

## DEALER ENQUIRIES WELCOME. GENEROUS DISCOUNTS

**SOFTWARE WRITERS.** We are looking for top class writers to join our growing software team. If you have written a quality game for Vic 20, Spectrum, Dragon 32, Oric 1 or Commodore 64, then contact us. We pay top royalties for accepted programmes.

## SPECTRUM — VIC 20 — ZX81 — DRAGON 32

Huge selection of software. Nearly all the software advertised here available post free. Pick and mix facility. Order for yourself and friends and get huge discounts. Send S.A.E. for catalogue. 5 tapes 10%. 10 tapes 15%. 20 tapes or more 20%.

Payment by cheque, P.O., Access/Visa.

**ANIROG COMPUTERS,  
26 BALCOMBE GARDENS,  
HORLEY, SURREY.**



**24 HR. Credit Card Sales.**

Horley (02934) 6083

ENQUIRIES Horley (02934) 2007/6083





# MAILBAG



## IMPERIAL LOSERS . . .

Dear Sir,  
If, in the Seventh Empire, a person making negative profit ends his turn on the same star as an Imperial Ship, will he lose twice as much or half as much? And how do I control an Imperial Ship?

*Stephen Loughran,  
Agamemnon Road,  
London,  
NW6*

**Editor's reply:** He loses twice as much. Stephen, which means that Imperial Ships can be used to inflict hard times on rivals, as well as boosting your own profits.

It makes these ships a double-edged weapon.

A ship can be controlled by putting all your ships into stars belonging to one empire and gambling that you will be the richest player to have tried to wrest control of that empire's ship.

## SKILL AND THE DRAGON

Dear Sir,  
Your correspondent in the February issue may be interested to know that I have tried the Tandy game Project Nebula and Chess on my Dragon 32.

The first works perfectly and the second only runs in skill level eight, the most difficult.

This is because the Dragon does not respond to the "L" command which is supposed to select the skill level. Has any reader managed to solve this problem?

*C. A. Sanders,  
Guisley,  
Leeds.*

## DEBUGGING A SPACE LASER

Dear Sir,  
In the November issue of *Computer and Video Games* you featured a game for the T.I. Space Laser.

Who did it this time? Mal Function, T-Hitch, Snag Jnr or Screaming Foul Up?

The bugs I found and debugged lines are:-  
420 CALL CHAR (112, "0000163066301800")  
1100 PRINT "GAME OVER"  
1170 PRINT "YOUR SCORE IS"&STR\$(SC)  
1260 GOTO 620  
Line 1470 should be deleted.  
1510 CALL HCHAR (24, 2, 32, 32)

There were bugs in lines 1530, 1570, and 1880. If there are any other bugs could you print the solution to them.

Also could you print a Defender type program. I am hoping to make a contribution to your pages. PS. Hungarian Hex was a real mind bender!  
*A. Howarth,  
Wigan,  
Lancashire.*

## COMPUTER IS VERY RUDE!

Dear sir,  
I have managed to use a telescope properly and the reward was a terrific view of what looks like a snake in the grass but I can't use anything else that the Pi-man gives me. And my computer is rude to me for trying. Help!  
*Gareth Mulgrave,  
Nottingham.*

**Editor's reply:** Do not ignore a single word of the text or any of the music.

The uses of the Pi-man's gifts are quite logical.

If you do silly things like trying to use your Deaf Aid in the Waste Disposal Unit, or use your Hang-glider in the Canal, then we are not surprised that your computer is losing patience!



## COMMANDING THOSE STICKS

Dear Sir,  
Your February issue of *Computer and Video Games* included a Missile Command game for the Dragon which I have amended for joysticks.

First delete lines 340 and 360 and change lines 330, 360, 370, 380, 430, 440 and 500 to:  
330 Z=JOYSTK(0):ZZ=JOYSTK(1):IF Z>10 AND Z<50 and ZZ>10 and ZZ<50 THEN 360  
360 IF Z>50 THEN  
A=A+5:IF A>255 THEN  
A=255  
370 IF Z<10 THEN  
A=A-5:IF A<0 THEN  
A=0  
380 IF ZZ>50 THEN B=B+5:  
IF B>170 THEN B=170  
430 IF ZZ<10 THEN B=B15:  
IF B<10 THEN B=10  
440 F=PEEK(65280):IF F =  
126 OR F=254 THEN F =  
=RND(3):GOTO 500  
500 U=F:IF M(U)=0 THEN  
450

The game now uses the right joystick. With the above amendments I have found the game easier to play and, to date, my highest score is 10,350.

*Richard White,  
Rotherham,  
S. Yorkshire*

## IS THIS A RECORD?

Dear Sir,  
We have currently solved/got maximum points in the following adventures for the Video Genie/TRS-80: Adventureland, Pyramid 2000, Pirate's Cove, Raaka-Tu, Mission Impossible, Lords of Karma, Voodoo Castle, Dog Star, The Count, Moonbase Gamma, Strange Odyssey, Lord's Keep, Mystery Fun House, Asylum, Curse of Crowley Manor, Asylum II, Golden Baton, and we are currently working on Pyramid of Doom.

Is this a record?

P.S. If you think Asylum is difficult, just try Asylum II!

P.P.S. If C&VG wants hints, we might consider payment — not a year's subscription, please!

P.P.P.S. If you ever consider replacing your

Adventureland columnist, please let us know!  
*Simon French and  
Craig Heath,  
Warwick.*

**Keith Campbell replies:** The Editor rolled about the floor with uncontrollable mirth when he read your letter! The thought of getting rid of me tickled him no end. Then Sue mentioned the bit about payment, and he quickly recovered and brewed himself a cup of strong coffee!

I pointed out I had solved Savage Island!! He said "Part 2?" and there was a deathly hush.

P.S. I might be mad, but I'm not stupid!

P.P.S. You'd be better off with the year's subscription!

P.P.P.S. I've a wife, three kids, a micro and a Tax Inspector to support — so hands off!!

## MISSING LINX . . .

Dear Sir,  
I have been buying your magazine regularly but so far I have not come across any games or educational programs for my new computer which is the Lynx. Has anyone out there got any programs for the Lynx? If so I'd love to see them!  
*John Noden,  
Truro,  
Cornwall.*

## GENIE BEATS THE GLUTTON

Dear Sir,  
I write to thank you for your note about the Glutton program and hasten to let you know I have stumbled across the trouble!

The Genie I has a ROM which is enabled by a SYSTEM call which amongst other things cures the keyboard bounce, provides a M/C monitor etc.

By NOT enabling this: ROM the program RUNS ok and indeed two other programs I have had trouble with also run properly.

There is nothing in the Genie manual about this so I hope this will help other Genie users who have encountered the problem.

*Lionel R. Howe,  
Burton-on-Trent.*

## CALLING ALL ARCADE CHAMPIONS

Have you ever been beyond the Scramble maze? Or seen the treasures of Tutankahmun? Perhaps you're a regular destroyer of the Zaxxon robot or a veteran of the fourth Donkey Kong screen.

If you're one of those intrepid few, for whom the arcade denizens hold no terror, then you should put your talents on show at our Best Arcade Player finals.

The championships start right here at the bottom of this page with a form to fill in your top score achieved on three machines.

These forms will be appearing in Computer & Video Games for the next two months and by June we should have some idea of who are the best arcade players around.

Taitel Electronics, who have brought many of the current arcade favourites into the UK are helping us to organise a grand finals day with a

OK so your name features all over the high score charts in the local arcade.

Well this form could take you into the big league with a crack at the Best Arcade Player title for 1983.

Simply cut it out and take it along to the local pub or arcade where your favourite machine lurks, put on the best score you can and ask the arcade manager or pub owner to witness the score on this form.

We'll need the name of the game, your score, where you achieved it and a date — plus your name and address of course.

But don't put all your eggs in one basket. If there's another machine you fancy your chances on, use the

top personality who also enjoys tackling electronic adversaries.

Then we will invite all the top scorers on the most popular machines — which will be judged purely on your response — along to show us what they can do and the best of these will be crowned the Best Arcade Player.

A table-top arcade game is the prize for the winner and all the

next category to fill in your best score on that too.

And there's a place for a third machine too. Your chances of reaching the final may increase with the number of different games you enter on. Should you produce a bad score, just try again.

You may also find the leaflets on display in your local arcade. If you notch up a good score after forgetting to bring the leaflet out, ask the arcade manager whether he's got some you could use.

The entries must be back with us by June 13th and should be sent to: Best Arcade Player, Computer & Video Games, Durrant House, 8 Herbal Hill, London EC1R 5JB.

finalists will get an expenses-paid trip down to London to take part and probably see some of the latest arcade games around too.

Last year the finalists were joined by the national press and Steve Davis, the top snooker star who also proved himself a dab hand at arcade games by taking on our champ Peter Edmonds at the game of Qix and beating him.

## Please enter the following scores in your 1983 Video Games Championships

My high score is:

.....

It was scored on a:

..... machine

Date:

The manager of the pub/  
arcade who witnessed my  
score is:

.....

His signature:

Name & address of pub/  
arcade:

.....

My name is:

Address:

.....

My high score is:

.....

It was scored on a:

..... machine

Date:

The manager of the pub/  
arcade who witnessed my  
score is:

.....

His signature:

Name & address of pub/  
arcade:

.....

My high score is:

.....

It was scored on a:

..... machine

Date:

The manager of the pub/  
arcade who witnessed my  
score is:

.....

His signature:

Name & address of pub/  
arcade:

.....

Tel:





Andrew Muir receives his prize at Bally U.K.'s headquarters

## MEET OUR PINBALL WINNER!

Bally's American team of top pinball designers are currently working out whether Alcatraz is likely to escape from their workshops.

Alcatraz is the brainchild of Andrew Muir of Grove Road, Norwich, who won the Bally Pinball design competition we featured in our September issue.

Andrew put the emphasis on skill with a barrier of drop targets which have to be knocked down to begin your escape path in an upper playfield.

Players are also given the chance to spell out "A-L-C-A-T-R-A-Z" in the lower playfield. His game also featured a captured ball and trying to get a ball through a moving hole.

The Bally judges were particularly impressed with the care and pinball knowledge Andrew displayed in his design.

Bally's US marketing vice-president Tom Nieman, was so impressed with the high standard of the entry he split the competition into two and awarded a second prize in

## RED, WHITE AND BLUE POSER

Could you help Farmer Nure with his blooming problem from our March issue?

If you worked out the plant's next bloom then you may find a Hungarian Ring Puzzle, destined to cause you further sleepless nights, on its way to you.

If not, this is the way to work out the plant's next blossom.

Each petal has "neighbours" with

the video game category to Ian Bofin of Lych Way, Woking, for his Jaws game.

Dave Adams of Bally UK entertained both winners at his Wembley HQ last month and presented Ian with his Intellivision games centre and Andrew with a super Vector pinball to set up in his home in Norwich.

An additional bonus for Andrew came in the shape of The Pinball Owners' Association granting him free membership. And it turns out that our winner will be member number 1,000!

Runners-up in the Pinball design class: Alexander Martin of Hamilton Crescent, Brentwood and David Payne, of Seaton Gardens, Ruislip.

In the video games design class Ian Farrelly of Quarry Road, Portishead came second and third equal were Peter King, of Church Lane, Walthamstow and Ian Rainford of Peel Hall, Wythenshawe. Free subscriptions to *C&VG* are on their way to this lucky few.

which it shares an edge line in our drawing.

For any petal, if an even number of neighbours also have its own colour then it keeps that colour in the next generation (yes, 0 is even!).

If an odd number of neighbours have its colour then it changes in the next generation in the sequence Blue to Red to White to Blue . . .

## CONFESSIONS OF A BUG

We may currently be micro-less but we're far from powerless. I personally claim responsibility for kidnapping the P9(J) from the end of line 2630 of the Book of Games' World Cup Manager program.

Nibblers fans with a Vic-20 can have their listing (January) improved by changing a few PEEKs and POKEs. A letter or a call to the *C&VG* offices will result in a copy of the necessary changes being put in the post.

Defuse gave Texas owners a difficult time after Screaming Foul-up ran riot in it. The following lines should be added or changed:

```
1110 R=RT
1120 C=CT
1130 CALL HCHAR(R,C,96)
700 C=RAN(28)+2
2590 CALL HCHAR(R,C+I,ASC(SEG$,1+1,1))
```

An anonymous fleet transmission was intercepted this month from the 15 players still wrapped up in the *C&VG* special Starweb game. Obviously a Berserker, keen not to give away his identity. Still we published it as it serves as a timely reflection on the poverty which still exists in points terms in some sectors of the galaxy.

Since I started my struggle for galactic domination it has got ever more complicated.

No longer is there an abundance of undiscovered worlds, easily captured or destroyed by my rampaging fleets. Not every planet is hard won by diplomacy or battle.

As a Berserker, I'm inclined to blow up planets, decimate populations and fill the universe with my robotic hordes. However, I've done very little of this concentrating upon creating an empire. Now that further expansion is difficult, I can just kill all my people and gain points quickly.

Doing this, I don't need any outside interference so I have tried to stay at peace with everyone. I am trading with a merchant and an artifact collector and so far, have met only two hostile players.

One of these, an apostle, refuses to answer any of my messages while an extremely insolent space pirate has recently captured one of my fleets. Unless he returns it, I will start a holy war, hoping my many allies will join in to destroy him.

Still the main problem is my unbelievably low galactic takeover rating. Just creeping over 100 points while other people have a thousand.

# SPECTRUM

## NEWS

from SPECTRUM

### ATARI 800

This proven and tested micro is now **UPGRADED** to 48K RAM and there's no increase in price either which must make it about the best value around. See our ad. for further details.

### ATARI 400

Now **REDUCED** by a MASSIVE £39 to an incredible price of only £159.95 from Spectrum.

### SINCLAIR ZX SPECTRUM

We have now added the super **SINCLAIR ZX SPECTRUM 16K** and 48K Models to our range - check our ad. for further details.

### NEW SPECTRUM MEMBERS

Check our address page! - there are many new SPECTRUM dealers throughout the UK so there's a good chance there'll be a SPECTRUM centre very near you.

### STOCKS

The general stock situation has now improved and you'll find that most SPECTRUM centres will be able to supply you immediately and at super LOW prices too!

### INTRODUCING SPECTRUM FACTS!

Next to many of our offers, you'll find a few lines tagged SPECTRUM FACTS. We pride ourselves on providing you, the customer, with a genuine service as well as super LOW prices, and we want you to know that when you buy from a SPECTRUM dealer, you'll get exactly the right Micro for your needs. **SO LOOK OUT FOR YOUR SPECTRUM FACTS!**

### After Sales care

SPECTRUM service centres will ensure that should your machine 'go-down' we will get it running again as quickly as possible. We also offer extended warranties at reasonable prices too! - ask your SPECTRUM HOME COMPUTER CENTRE for full details.

### COMPUTER DEALERS!

(or prospective Computer Dealers!) If you would like to know more about becoming a SPECTRUM APPOINTED DEALER on an exclusive area basis, please write to MIKE STERN, Spectrum (U.K.) Ltd., Burrowfield, Welwyn Garden City, Herts.

## COLOUR GENIE

A truly reliable micro and highly recommended by Spectrum.



The new COLOUR GENIE features powerful and sophisticated COLOUR GRAPHICS, allowing you to create full 8-colour Games, Diagrams and Charts quickly and simply.

At its low SPECTRUM price, the Colour Genie is amazingly versatile - its Powerful 16K RAM memory (expandable internally to 32K) means FULL COLOUR video games and POWERFUL COMPUTING with a full range of inexpensive accessories: 16K RAM pack, Joysticks for TV games, Light Pen, Disk Drive and a Printer.

But that's not all - the Colour Genie also features a 16K ROM Memory with 128 Upper and Lower case Colour Graphics Characters already stored, plus sound, a professional typewriter keyboard. In use, it's as straightforward as any, thanks to the use of BASIC language and direct keyboard accessed colour commands.

The superb Colour Genie is at SPECTRUM now - check it out and see the Genius at work!

Spectrum **LOW Price**  
**£224.48**  
Inc. VAT

#### COLOUR GENIE ACCESSORIES

Joysticks.....	£49.49
16K RAM.....	£38.50
Printer Interface.....	£39.95
VISCOUNT Teach yourself Colour Genie BASIC.....	£6.95

#### SPECTRUM FACTS

Maximum user RAM.....	14,200 Bytes (approx)
Text Screen.....	24 x 40
High Resolution.....	160 x 96
Cassette Lead.....	Included

## LYNX

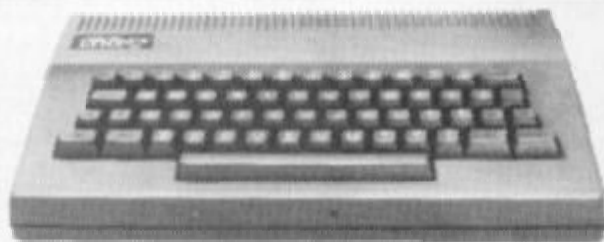

Just look at this super new LYNX Micro - an incredible 16K + 32K video ram and that's expandable up to or beyond 96K. For just £225.00 INCLUDING VAT the LYNX is exceptionally versatile. All LYNX's 'add-on' connections are standard types. The high definition colour graphics make it a top-value choice for the home or office (with expansion, the LYNX can become an 80 characters-per-line word processor!) Take a look at the LYNX - a memorable bargain from SPECTRUM. But please phone to check stock position before making a journey as this new machine is bound to be in great demand.

Spectrum **LOW Price** **£225.00**

VISCOUNT - Teach yourself LYNX BASIC £6.95

#### SPECTRUM FACTS

Maximum user RAM.....	13,700 Bytes (approx)
Text Screen.....	24 x 40
High Resolution.....	265 x 248
Cassette Lead.....	Included

## ORIC-1

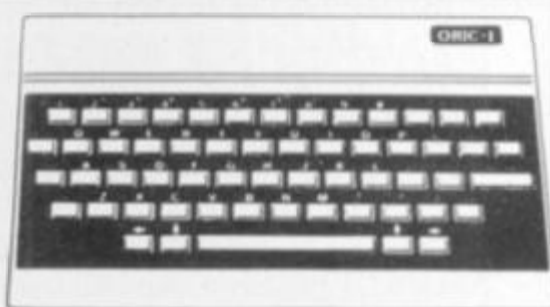

A superbly designed and engineered micro and great value-for-money from SPECTRUM. Offering 48K RAM Colour - (8 foreground and 8 background can be displayed at same time) High resolution graphics User definable Graphics. Full sound (5 octaves of controllable sound.) Easy to use keyboard with moving keys. Standard Centronics parallel interface allows easy connection to a wide range of printers etc.

Spectrum **LOW Price** **£169.95**  
Inc. VAT

#### SPECTRUM FACTS

Maximum user RAM.....	47,870 Bytes
Text Screen.....	28 x 40
High Resolution.....	240 x 200
Cassette Lead.....	Included



## JUPITER ACE

Outstanding value-for-money! The JUPITER ACE uses easy to understand FORTH language. Connects to your own TV. 3K RAM expandable to 19K. Full moving keyboard with auto repeat and caps lock. Full sound and chunky graphics. If you've wanted to learn an impressive Language then this is the machine for you.

Spectrum **LOW price** **£89.95** Inc VAT  
£76.22 ex vat

SPECTRUM FACTS  
Maximum user RAM 1,000 Bytes approx.

# HURRY! Limited stocks only- DRAGON



Unbelievable value at only £199.95 from SPECTRUM! British built and designed it's one of the most impressive micros to appear for quite some time. Extensive facilities include highly advanced colour graphics. Just look at this top specification: Powerful standard 32K RAM (expandable to 64K Bytes) ■ 9 Colour, 5 resolution Display. ■ Extended Microsoft colour BASIC (as standard) ■ Advanced sound with 5 octaves - 255 tones. ■ Professional style editing, e.g. extract line, auto find reinsert. ■ Professional quality keyboard. ■ Centronics Paralleled printer interface. ■ Serious programmer/user - the BASIC on this machine is similar to that found on machines costing 3 times the price! ■ Uses almost any cassette recorder. ■ Standard file handling ON TAPE.

**Spectrum LOW price** **£199.95** INC. VAT

## SPECTRUM FACTS

Maximum user RAM ..... 29,679 Bytes  
Text Screen ..... 16 x 32  
High Resolution ..... 256 x 192  
Cassette Lead ..... Included

	EX VAT	INC VAT		EX VAT	INC VAT
<b>ACCESSORIES</b>					
Joysticks (pair)	£17.35	£19.95	Madness and the Minotaur	£6.91	£7.95
Cassette Lead	£2.35	£2.70	<b>Examples from</b>		
<b>CARTRIDGES</b>					
Beserk	£17.35	£19.95	Dragon Manual	£6.91	£7.95
Cosmic Invaders	£17.35	£19.95	Personal Finance	£6.91	£7.95
Meteoroids	£17.35	£19.95	Dragon Mountain	£6.91	£7.95
Ghost Attack	£21.70	£24.95	Typing Tutor	£6.91	£7.95
Cave Hunter	£17.35	£19.95	Black Sanctum	£6.91	£7.95
<b>Starship</b>					
Chameleon	£17.35	£19.95	<b>VISCOUNT Software for DRAGON</b>		
<b>CASSETTES</b>					
Calico Island	£6.91	£7.95	Teach yourself Dragon Basic	£6.95	
Graphic Animator	£6.91	£7.95			
Quest	£6.91	£7.95			



# ATARI 800

Now this proven and tested machine has been upgraded to a massive 48K RAM and it's still at the amazing LOW price of £399.99 from SPECTRUM. It's an ideal Home Micro for graphics, educational and personal finance etc. use and it will take you from learning up to small business use. You can add printers, program recorders, disk drives and more, to expand your micro as and when you want, to suit your needs. So if you're looking for a top-of-the-line micro you must see the ATARI 800 with 48K at SPECTRUM - NOW!

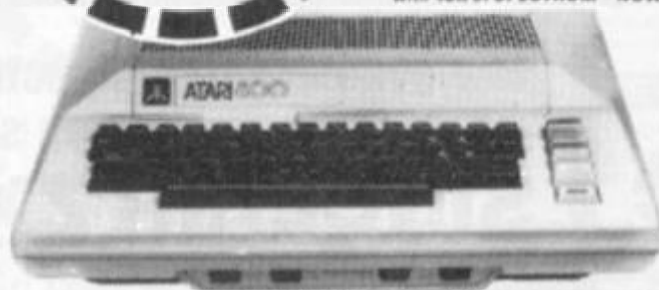

Spectrum LOW Price

**£399.99** INC. V.A.T.

**SPECTRUM FACTS** Maximum user RAM ..... 37,899 Bytes  
Text Screen ..... 24 x 40  
High Resolution ..... 320 x 192  
Cassette Lead ..... Needs own Recorder

## ATARI 400

16K RAM



**NOW ONLY**  
**£159.95** INC. VAT

BASIC cartridge extra  
**£39.99 inc. VAT**  
(£34.77 ex. VAT)

## SPECTRUM FACTS

Maximum user RAM ..... 13,323 Bytes (with basic Cartridge)  
Text Screen ..... 24 x 40  
High Resolution ..... 320 x 192  
Cassette Lead ..... Needs own Recorder

**ATARI DISK DRIVE**  
**£299.00** INC. VAT

## ACCESSORIES, BOOK & GAMES for ATARI

Accessories	INC VAT	European Countries & Caps	INC VAT
Thermal Printer	£198.95	Hangman	£14.99
16K RAM Pack	£65.00	Kingdom	£14.99
400 Keyboard	£59.95	States & Capitals	£14.99
32K RAM board (400/800)	£75.00	Touch Typing	£19.99
48K RAM board (400/800)	£99.00	Music Composer (Cartridge)	£35.99
Paddles (Pair)	£13.99	<b>Home Entertainment (Cartridge except where stated)</b>	
Joysticks (Pair)	£13.99	Galaxian	£29.99
I/O Cable	£12.99	Defender	£29.99
Printer Cable	£28.50	Asteroids	£29.99
Monitor Cable	£25.00	Basketball	£24.99
Thermal Paper	£4.00	Blackjack (Cassette)	£14.99
Pointmaster Joysticks	£14.95	Caverns of Maia (Disk)	£29.99
Quickshot Joysticks	£14.95	Centipede	£29.99
Keyboard for Atari 400	£80.00	Computer Chess	£24.99
<b>Books &amp; Manuals</b>		Missile Command	£29.99
Wiley Manual	No VAT	PAC Man	£29.99
Basic Reference Manual	No VAT	Space Invaders	£29.99
DOS. 2 Manual	No VAT	Star Raiders	£29.99
Operating System Listing	No VAT	Cribbage & Domino	£19.95
DOS. Utilities Listing	No VAT	European Scenic Jig-saw	£19.99
<b>Home Computer Programs - Home/Office</b>		<b>Programming Languages &amp; Aids</b>	
Word Processor (Disk)	£99.99	Assembler Editor	£39.99
Mortgage & Loan	£14.99	Atari Basic Cartridge	£39.99
Microsoft Basic (Diskette)	£59.99	Macro Assembler (Disk)	£59.99
<b>Home Study (Cassette except where stated)</b>		Pilot (Consumer)	£59.99
INV. to programming 1	£19.99	Pilot (Educator)	£89.99
INV. to programming 2	£22.99	Entertainer Kit (Star Raiders Missile Command & Pair Joysticks)	£69.99
INV. to programming 3	£22.99	Programmer Kit (Basic Cartridge & Manuals)	£39.99
Conversational French	£39.99		
Conversational German	£39.99		
Conversational Italian	£39.99		
Conversational Spanish	£39.99		

# Commodore VIC-20



Now a top quality home/business micro for the price of a games machine.

■ Memory expandable to 32K ■ High resolution (full PET type) graphics ■ 16 Screen colours and 8 border colours ■ Plugs in to your TV, or monitor ■ Add Disk Drive & Printer for impressive 170K Byte system ■ Can act as an intelligent terminal for a larger computer.

**£129.90** INCLUDING VAT

## SPECTRUM FACTS

Maximum user RAM ..... 3,853  
Text Screen ..... 22 x 23  
High Resolution ..... 178 x 158  
Cassette Lead ..... Needs own Recorder

## COMMODORE 64

Very limited supplies of this new micro now available - please check with your local SPECTRUM dealer before making a journey.

**Spectrum LOW Price** **£345.00**

# TEXAS TI99/4A

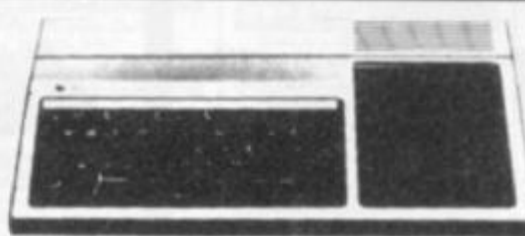

■ 16K RAM (expandable to 48K) ■ Built-in 14K Byte BASIC interpreter ■ 16 Bit Micro-processor ■ 16 Colour High Resolution graphics ■ Extensive range of solid state software command modules available from games to architectural aids.

**Spectrum LOW Price** **£154.95** INC VAT (£134.74 ex. VAT)

## SPECTRUM FACTS

Maximum user RAM ..... 14,500 Bytes (approx.)  
Text Screen High Resolution ..... 256 x 192  
Cassette Lead ..... Extra £10.95

TEXAS PERIPHERALS	EX VAT	INC. VAT	Parsel <th>EX VAT</th> <th>INC. VAT</th>	EX VAT	INC. VAT
Speech Synthesizer	£40.50	£46.58	Car Wars	£23.43	£26.95
Peripheral Exp. System	£122.00	£14.30	Munchman	£23.43	£26.95
Disc Cont. Card	£124.30	£142.95	Adventure & Pirate	£31.26	£35.95
Disc. Drive	£234.74	£269.95	<b>Education</b>		
RAM Exp. Card	£179.57	£206.50	Number Magic	£12.13	£13.95
Matrix printer	£347.78	£399.95	Addition/Subt. 1	£23.43	£26.95
<b>Software Entertainment</b>			<b>Teach yourself beginners</b>		
Ti Invaders	£16.48	£18.95	BASIC	£8.26	£9.50
Tombstone City	£19.96	£22.95	Home Budget Management	£19.96	£22.95
Attack	£19.96	£22.95	and many more		

## VISCOUNT SUPER X2 64K DYNAMIC RAM PACK for VIC-20 EXCLUSIVE TO SPECTRUM!

Unbelievable-but-true, now you can upgrade your VIC-20 from 3.5K to a massive 67K RAM. Enables you to load up to 8 games or programs at a time & still select which one you wish to use. Can be used in conjunction with other expansions to increase total memory up to 152K-using the VIC memory expansion board. The SUPER X-2 will make your VIC-20 the biggest little micro in town!

**Spectrum LOW price** **£114.94** INC. VAT

**MORE SPECTRUM LOW PRICES**

# SPECTRUM

A few examples from our  
**Software SELECTION**  
 from independent software houses

## THORN EMI

Software for Atari	Inc. VAT
Submarine Commander	£34.44
Jumbo Jet Pilot	£34.44
Soccer	£28.84
Kickback	£29.84
Home Financial Management	£19.49
Darts	£19.49
Snooker & Billiards	£19.49
Pool	£19.49
Cribbage & Dominoes	£14.89
Cupute 4 & Reversi	£14.89
Mutant Herd	£24.25
Software for Commodore	
River Rescue	£25.24
Vic Music Composer	£25.24

## GEM

Software for ZX81, Dragon and Spectrum	Inc. VAT
Monster Mine (for ZX 81)	£4.95
Monster Mine (for Spectrum)	£4.95
Monster Mine (for Dragon)	£7.95
Space Mission (for ZX 81)	£4.95
Space Mission (for Spectrum)	£4.95
Space Mission (for Dragon)	£7.95
Dragon Golf	£7.95
Dragon Character Generator	£9.95

## SALAMANDER

Games for Dragon 32	Inc. VAT
Dragon Trek	£9.95
Wizard War	£7.95
Vulcan GI+	£7.95
Games Compendium DI	£7.95
Golf	£7.95

## RABBIT

Software for Commodore VIC20	Inc. VAT
Space Storm	£6.49
Ski Run	£4.49
Dune Buggy	£4.49
Super Worm	£4.49

## ACCESSORIES



**SANYO Colour Monitor CDD3125N ONLY**  
**£228.85 inc. VAT**  
 (£199.00 ex. VAT)

SANYO 12" green monitor	Inc. VAT	£80.50
Slim 3G Cassette Recorder	£29.95	
CTP 3131 14" Colour TV Set	£229.95	
C12 Cassettes	£0.50	
Single sided, single density disks	£1.95	
Double sided, double density disks	£3.38	
Disk head cleaner	£16.10	

Single part 11" x 9 1/2" printer paper, box of 2,000 sheets	£13.05
VIC-20 Accessories from Viscount	
Motherboard without Buffer	£24.95
Motherboard with Buffer	£29.90
16K RAM Pack	£43.95
32k RAM Pack	£66.95
64K RAM Pack	£114.94
Currah Chatterbox Voice Synthesiser	£57.45

Now available from Spectrum Computer Centres—the top selling:-  
**SINCLAIR ZX-SPECTRUM**



Yes, this top selling micro is now available from your local SPECTRUM COMPUTER CENTER in both 16K and 48K RAM. So now there's no need to send by mail order, just call into your local SPECTRUM dealer and pick one up. But just one word of warning, with this added availability advantage stocks are bound to sell fast - so make it soon!

**SINCLAIR ZX SPECTRUM 16K - £125.00**  
**SINCLAIR ZX SPECTRUM 48K - £175.00**  
 Spectrum Computer Centres have no connection whatsoever with the ZX-Spectrum Computer manufactured by Sinclair Research Ltd.

## SINCLAIR ZX-81

**SINCLAIR ZX . . . £49.95**  
**16K RAM pack . . . £29.95**  
**ZX Printer . . . £59.95**

Computer Bookshop Software for Sinclair Computers	INC. VAT	
Bumper 7 1K ZX81	£5.95	
1K Super Trio ZX81	£7.95	
Labyrinth 16K ZX81	£5.95	
Nightmare Park/Music 16K ZX81	£6.95	
Computacalc 16K ZX81	£7.95	
Personal Banking System 16K ZX81	£11.44	
Space Invaders/Rescue 16K ZX81	£6.95	
Breakout 16K ZX81	£5.95	
Mugsy 16K ZX81	£5.95	
Mergatroyds 16K ZX81	£5.95	
Pogmorge 16K ZX81	£5.95	
Football Manager 16K ZX81	£7.95	
Cassettes for ZX81 Type-10	£3.95	
6 Games	£3.95	
Junior Education	£3.95	
Business & Household	£3.95	
Skill & Judgement Games	£3.95	
Junior Education	£3.95	
Family Quiz	£3.95	
Type-20		
Fantasy Games	£4.75	
Space Raiders & Bombers	£4.75	
Type-30		
Super Programs Nos. 1-8	£4.95	
Type-40		
Backgammon	£5.95	
Fight Simulation	£5.95	
Type-50		
English Literature 1	£6.95	
English Literature 2	£6.95	
Geography	£6.95	
History 1	£6.95	
Maths. 1	£6.95	



Give your ZX81 the power of a big micro!  
**CHEETAH 64K RAM PACK ONLY £54.95**

## Quality PRINTERS at super LOW prices from Spectrum

### EPSON

Model MX80-T3 . . . £378.35  
 MX80 F/T Type III . . . £424.35  
 MX100 Type III . . . £539.35  
 Please see your SPECTRUM dealer for prices of INTERFACE/CABLE options.

### SEIKOSHA

GP-100A  
 Now a top quality graphic printer at a price you can afford. Centronics interface connects easily with most micros.  
**Spectrum LOW price £229.94 inc. VAT**  
 Cables & Interfaces available for most micros.

### SMITH CORONA

Model TP-1  
 Microprocessor controlled, high quality daisy wheel printer at a LOW cost from SPECTRUM. Serial, Parallel or IEEE Interface.  
**Spectrum LOW price £557.75 inc. VAT**

INC. VAT

LOW price

LOW price



## BOOKS

SELECTION FROM THE COMPUTER BOOKSHOP	
30 Hour Basic for the B.B.C. Micro	£5.95
Let your B.B.C. Micro Teach You To Programme	£6.45
B.B.C. Micro Revealed	£7.95
Over The Spectrum	£6.95
80 Games and Applications for the Zx Spectrum	£4.95
Programming The 6502	£9.95
Programming Your Zx Spectrum	£6.95
ZAP Pow Boom for the Vic 20	£7.95
The ZX Spectrum Explored	£5.95
Vic Innovative Computing	£6.95
Mastering Machine Code on Your Zx81	£7.50
The Zx Spectrum and how to get the most from it	£5.95
Easy Programming for the ZX Spectrum	£5.95
30 Programmes for the B.B.C. Micro	£4.95
CPM Handbook	£11.50
Programming the Z80	£11.95
20 Best Programmes for the ZX Spectrum	£5.95
Getting Acquainted with your Vic 20	£6.95
Machine Code and Better Basic	£7.50
The Cambridge Colour Collection (Spectrum)	£6.95
Vic Revealed	£10.00
De RE Atari	£17.00
ATARI Operating system listing	£10.43



# NEW PRODUCTS NEW PRODUCTS NEW PRODUCTS NEW PRODUCTS

# GAMES NEWS

## TEDDY TAKES ON THE TROOPS

### AH, DIDDUMS!

New from Imagine this month is cute novelty game called Ah Diddums. There is more than a touch of Mary Poppins in this game where the goodies of the toy box team up against the baddies.

You control a small teddy bear armed with a pea-shooter and a supply of wellington boots which can be flung at the tin soldiers, a nasty train set, and various ugly shapes of plasticine — all of which are out to get poor Edward Bear.

You have to fight off these nursery nasties before they knock the stuffing out of Teddy!

Ah Diddums runs on the Sinclair Spectrum in 16 or 48K.

The game is available by mail order from Imagine Software of Liverpool and at some larger branches of W. H. Smiths at £5.50.

## ADVENTURE AND ACTION FOR ORIC

### ORIC

Bug Byte, Psion, Salamander and Quicksilva are some of the established software houses that have been signed up to write games for the new Oric computer which has just gone on sale.

The £100 machine which will compete directly with the Spectrum and will also have a range of games under Oric's own label. These will include Chess, Go, Adventure and Invaders.

Bug Byte will supply a text only adventure called The Castle, Salamander will produce Backgammon, 3D Maze, a Star Trek-type game and an adventure, and Quicksilva are working on an original arcade style game.

Other games listings will be published in the Oric owners magazine which is to be published every two months.

Computer and Video Games will also be publishing a professionally written game for the Oric in our June issue.



## GET DUG IN TO BEAT THE MONSTERS

### APPLE PANIC

Creative Software titles coming into the UK from America include Apple Panic, a game in which you must dig holes to trap the Apple monsters that are pursuing your little man.

Serpentine introduces snakes and frogs into the maze chase style game. In order to survive you have to avoid or devour the hostile red serpents. If you do, you can lay eggs and hatch baby snakes.

The games are sold in the UK by Audiogenic of Berkshire and are in the shops now at £24.95.

## WATCH THE BIRDIE ON A DRAGON!

### DRAGON GOLF

If it's too wet for your Saturday morning round of golf and you can't face the weekend without it then relax as you may still be able to get a hole in one with this latest golf simulation for the Dragon.

Dragon Golf is a nine hole golf course incorporating many features of the real game.

Each hole is displayed as played including all bunkers, water

hazards and greens. In addition, wind strengths and directions play an important part in the match as well as ensuring that each hole plays differently, even if the same clubs are selected by each player.

You can select from a full range of clubs including woods, irons, and putters and can choose the angle of shot and the strength of stroke as you aim for a hole in one.

Dragon Golf is available from Reading-based Audiogenic on tape at £5.00.

## ESCAPE FROM THE PLANET OF DANGER

### ORION

Escape from Orion is a new BBC space game incorporating some of the features of the popular arcade game Donkey Kong.

Your flying saucer is moved backwards and forwards with the joystick and hops by depressing the fire button.

Four screens of progressive difficulty must be negotiated with a bonus score for each screen successfully completed.

As you proceed your ship must hop up to collect resources you need for the voyage: fuel rods, tools, water, oxygen.

Escape from Orion runs on the BBC model B and is available at £6.75 inclusive from Hopesoft of Berkshire.

## WATCH OUT THERE'S A MINE ABOUT!

### MINED OUT

You'll have to watch where you are treading in Quicksilva's latest game.

Mined Out challenges you to get safely across a field which is riddled with enemy mines. Put one foot in the wrong place and you'll be blown to bits.

To aid you in this perilous jaunt you are given a mine detector and some safe areas around the edges of the mine field where you can walk unharmed.

To add interest the fields are inhabited by a couple of hostile creatures: bugs and mine spreaders. Watch your step!

Mined Out is for the 48K Spectrum only and is in the shops now at £4.95.

ZX81 owners have also been included in this month's new releases from Quicksilva with three 16K games based on well known arcade money spinners.

Kroka Crawla is a version of Frogger, Munchies is a maze gobbling game similar to Pac-man, and there is also a Galaxians with an extra bonus game on the same tape called Gloops. Kroka Crawla and Munchies will sell for £3.95 and Galaxians is a little dearer at £4.95.





# NEW PRODUCTS NEW PRODUCTS NEW PRODUCTS NEW PRODUCTS NEW PRODUCTS

# GAMES NEWS

## SEARCH FOR PRICELESS GOLD FLEECE

### ARGONAUTS

Dragon owners may encounter a few dragons of the fire-breathing variety when they team up with Joseph and the Argonauts in the search for the golden fleece.

This priceless treasure is hidden on one of the numerous islands which are scattered throughout the seemingly endless seas which your battered ship must navigate.

As well as dangerous encounters with sea serpents, storms, yellow fever and the plague, you are constantly dogged by a thick mist which can cause you to go wildly off course.

You have a limited amount of fuel and food to last the voyage. This is randomly decided by the computer each time you play.

Joseph and the Argonauts is a part text and part graphics adventure. The game is the latest addition to the range of games from Item Limited for the Dragon home computer. It is available from the Berkshire-based firm at £4.95 inclusive.

## SUPERSTORE NEEDS A SUPER 'TEC

### SNATCHER

If you have ever wondered exactly what your boss thinks of you then you will be left in no doubt when you play Catch a Snatcher on the unexpanded Vic.

Your popularity rating with the boss is displayed as a constantly changing percentage, depending on your performance.

You are a store detective patrolling a large department store. Shoplifters, lost children, lost property, lost dogs, and even a terrorist bomb must all be dealt with by you - the diligent security officer.

Escort a stray dog out of the food hall and your popularity rating goes up but let a thief get away with a portable telly and it falls straight back down again.



Your rating begins at fifty per cent and, if you go above the ninety nine percent mark, you progress on to a new but more difficult floor. The game is available by mail order from Imagine Software of Liverpool and larger branches of W. H. Smith at £5.50.

## SCRAMBLING WITH THE INVADERS . . .

### ARCADIA

Two hit arcade games on one tape is the latest offering from the well established Sinclair software house - J. K. Grey.

Scramble and Invaders are the titles from the arcades with another two giveaway games thrown in for good measure.

Arcadia is the name of the games pack and it runs on the Sinclair Spectrum in 16 and 48K. It is available at £4.95 from the Bath-based firm.

## RETURN TO THE WORLD OF ZORK

### ZORK III

Adventure fans will need no introduction to the Zork tales which are becoming as popular in the U.S. as the classic Scott Adams adventures.

If you managed to get to the Stone Barrow in Zork, and became Master of the Domain, having defeated the senile Wizard of Frobozz in Zork II, then you will be anxious to enjoy the action of

the final and concluding tale.

Zork III starts with you placed at the bottom of a long staircase.

At the end of the staircase is the Treasure Room filled with all the treasures of Zork.

The conclusion has an unusual twist, although you will need to use an equally unusual approach to get that far.

Zork I, II, and III are available, on disc only, for the Apple and Atari computers.

The Atari versions are available from Calisto Computers of Birmingham at £30 each and the Apple versions from Pete and Pam Computers of Rossendale, Lancashire at £25.95.

## MONKEY BUSINESS WITH KONG!

### KRAZY KONG

What do you get if you take a gorilla, a blond starlet, and a mad carpenter called Mario. Correct - you got it in one, it's Donkey Kong! More accurately, it's Krazy Kong, in this new version of the hit arcade game for the 16K ZX81.

The game has three screen presentations with tumbling barrels, money bags and lifts. It is available from Personal Software Services of Coventry at £3.95, including postage and packing.

Spectrum owners have also been included in the new releases from PSS with a scrolling maze game. The idea of Maze Death Race is to escape from an enormous maze before the evil cars run you down. Maze Death Race is available at £4.95.

## I'VE GOT YOU UNDER MY SKIN!

### MANGROVE

Beneath the surface of your skin a major battle is being fought!

On one side are the massed ranks of cells that cluster together in groups of four, in defensive formation to withstand the onslaught from the attacking microbes.

Until recently you would have needed an extremely powerful microscope to witness this fantastic battle. But now you can not only see the action on your screen but you can actually take part yourself fighting the good fight against the disease bringing microbes, in Mangrove, an original game from Supersoft.

Move around the screen using the joystick depositing cells as you travel. Only cells in groups of four can survive.

To beat off the microbes you are armed with three smart bombs which will kill off all the microbes on the screen.

Points are awarded for each cell deposited and these are counted up on the sixth beat of the heart which pumps continuously throughout the game.

Every five thousand points there is a microbe storm so you had better keep a smart bomb or two in reserve.

Mangrove runs on a Commodore Pet and is available at £8 from Supersoft of Harrow with Vic-20 and Commodore 64 versions in the pipeline from Audiogenic Ltd of Reading.

# NEW PRODUCTS NEW PRODUCTS NEW PRODUCT GAMES NEWS

## SPLICE THE MAINBRACE, LANDLUBBERS

### SAILING

If you're keen on simulations but think flying is for the birds a Dublin software company suggests you try your hand at sailing.

With Sailing Simulator you are in charge of a 50 foot sailing yacht with a screen split into two halves. The top half devoted to an instrument display and the bottom half showing a map.

The display gives the level of heel of the boat, or whether you are likely to ship water. There is a profile of the ship showing the amount of sail, a control for the anchor, a picture of the boat from above which shows where the wind is coming from and a compass heading.

Your five controls feature port and starboard, increasing and reducing sail and finally the anchor. While a text display gives the weather forecast.

Your job is to navigate into three imaginary ports which vary in difficulty. When approaching land the map changes to show the coastal charts and you must take care not to run aground. The weather is also a product of the programmer's imagination but mainly moderate - although you may find yourself up against a hurricane or a high swell.

The game runs on a 48K Spectrum and costs about £5 from Soft Options of Castle Nock, Co. Dublin.

## DON'T DRINK AND JUMP THE ROAD!

### DARE-DEVIL

Sharp MZ-80K owners are in for a bumper choice of games from a new range just on sale.

Dare-Devil is based on the popular arcade game Frogger - though instead of getting a frog safely to the spawning grounds you are charged with the far more important task of getting the dare-devils across the road



to the pub. Could be thirsty work! Encounter challenges you to stop a Martian spaceship landing on planet earth.

The third original game on Games Pack Four is Railroad where you control several trains on a network railway. Switch the points quickly to stop them crashing. Pontoon and Pinball are also included.

Three simulations are the main attractions on Games Pack Five which enable you to drive a car, fly a plane, and command a fleet in the mid-Atlantic sea battles of World War Two. Noughts and Crosses and a maze chase game are also featured.

Games Pack Six offers a 23K adventure called Lost in the Jungle which challenges you to find your way back to civilisation and overcome attacks from wild beasts you will encounter on your way. This is a part text and part graphics adventure.

If you fancy becoming a Wizard and attempting to cast a spell on an unruly dragon then Games Pack Seven may be more your cup of tea. This cassette also features Air Attack - an air sea battle in which you command a warship, Take Away which is a version of Solitaire, and two original games called Plonker and Trap.

The Games Pack range are all available from Remus Software of Manchester, at £6 each.

## WHO WANTS TO BE A MILLIONAIRE? MONOPOLE

Monopoly - that famous Waddingtons board game has been converted for play on your home computer.

This should enable you to avoid having to use a thimble or twenty pence piece when your favourite boot or top hat has been lost and the 500 pound notes and title deeds to Mayfair and Park Lane have been chewed up by the cat.

No harm can come to the pieces in computer Monopoly as everything you need to play is safely stored away on cassette.

Monopole - with an 'e' not a 'y' presumably to avoid copyright problems - runs on the Commodore 64 and costs £9.99 from Rabbit Software of Harrow.

Commodore 64 owners can also look forward to a range of adventure games to play.

The first three games on Adventure Pack 1 are Moonbase Alpha, Big Bad Wolf, and Computer Adventure. Adventure Pack 2 will follow shortly with a graphic Adventure called Grave Robbers.

These will also be available at £9.99.

## THIS GREAT LITTLE MOVER!

### PHANTOM CHESS

The Phantom Computer Chess machine is a great little mover. Not only does it play to a good standard but it needs no manual help in advancing pawns, leaping knights are castling. It's all done by magnets.

It will quite happily play itself while you watch from a distance. And then set out the pieces again for another game.

It has 12 game levels and comes with a booklet showing the rudiments of chess for a complete beginner. It further helps beginners by analysing their next move for them.

The game is marketed by Milton Bradley and sells for around £300. It is set in a large black square of moulded plastic.

The knight is moved by clearing a path past the intervening pawns and taken pieces are moved off-board onto two strips with the appropriate symbols.

If a human player hopes to take on the machine it responds as a sensory board and also plays a good range of openings.

## BLAST THOSE TOUGH LITTLE INVADERS

### SCRAMBLE

Two new shoot 'em up games are on offer from Mikro-Gen.

Scramble is a version of the now famous scrolling arcade game where you have to fly over an uneven landscape, bombing fuel dumps and shooting down aliens, whilst dodging fireballs and ground to air missiles.

Cosmic Raiders is a version of Defender, the toughest of all arcade games. You fly a ship over a planet's uneven terrain, protecting humanoids from the Landers and the Grabbers.

Scramble and Cosmic Raiders run on the Spectrum in 16 or 48K and are available from the Bracknell firm at £5.50 plus 40p postage and packing.

# 100 FREE PROGRAMS

FROM SILICA SHOP — WITH EVERY PURCHASE OF AN

# ATARI 400

# 800



## REDUCED PRICES

We at Silica Shop are pleased to announce some fantastic reductions in the prices of the Atari 400/800 personal computers. We believe that the Atari at its new price will become the U.K.'s most popular personal computer and have therefore set up the Silica Atari Users Club. This club already has a library of over 500 programs and with your purchase of a 400 or 800 computer we will give you the first 100 free of charge. There are also over 350 professionally written games and utility programs, some are listed below. Complete the reply coupon and we'll send you full details. Alternatively give us a ring on 01-301 1111 or 01-309 1111.

ATARI 400 with 16K	<b>£159</b>
ATARI 400 with 48K	<b>£228</b>
ATARI 800 with 48K	<b>£349</b>

## 400/800 SOFTWARE & PERIPHERALS

Don't buy a T.V. game! Buy an Atari 400 personal computer and a game cartridge and that's all you'll need. Later on you can buy the Basic Programming cartridge (£35) and try your hand at programming using the easy to learn BASIC language. Or if you are interested in business applications, you can buy the Atari 800 + Disk Drive + Printer together with a selection of business packages.

Silica Shop have put together a full catalogue and price list giving details of all the peripherals as well as the extensive range of software that is now available for the Atari 400/800. The Atari is now one of the best supported personal computers. Send NOW for Silica Shop's catalogue and price list as well as details on our users club.

THE FOLLOWING IS JUST A SMALL SELECTION FROM THE RANGE OF ITEMS AVAILABLE:

<b>ACCESSORIES</b> Cabin Cassettes Diskettes Joysticks Le Stick - Joystick Misc Supplies Paddles	Mountain Shoot Rearguard Star Flite Sunday Golf	<b>BUSINESS</b> Calculator Database Manager Decision Maker Graph-It Invoicing Librarian Mort & Loan Anal Nominal Ledger Payroll Personal Finl Mgmt Purchase Ledger Sales Ledger Statistics 1 Stock Control Telexlink 1 Visicalc Weekly Planner Word Processor	<b>DYNACOMP</b> Alpha Fighter Chompelo Crystals Forest Fire Intruder Alert Monarch Moonprobe Moving Maze Nominos Jigsaw Rings of The Emp Space Tilt Space Trap Stud Poker Triple Blockade	Maths-Tac-Toe Metric & Prob Solvg Mugwump Music Terms/Notatn Musical Computer My First Alphabet Number Blast Polycalc Presidents Of U.S. Quiz Master Starware Stereo 3D Graphics Three R Math Sys Video Math Flash Wordmaker	Scream States & Capitals Touch Typing	<b>EMLSOFTWARE</b> British Heritage Cribbage/Dominos Darts European Scene Jig Humpty Dumpty Jumbo Jet Lander Snooker & Billiards Submarine Commdr Super Cubes & Tilt Tournament Pool	Castle Centurion Checker King Chinese Puzzle Codecracker Comedy Diskette Dice Poker Dog Date Domination Downhill Eastern Front Galalah & Holy Grl Graphics/Sound Jax-O Jukebox Lookahead Memory Match Midas Touch Minotaur Outlaw/Howitzer Preschool Games Pro Bowling Pushover Rabbitz Rivers II Salmon Run 747 Landing Simul Seven Card Stud	Sleazy Adventure Solitaire Space Chess Space Trek Sultans Palace Tact Trek Terry Wizards Gold Wizards Revenge	Jawbreaker Mission Asteroid Mouskattack Threshold Ulysses/Golden Fl Wizard & Princess	<b>PERIPHERALS</b> Centronics Printers Disk Drive Epson Printers Program Recorder RS232 Interface Thermal Printer 16K Memory RAM 32K Memory RAM	<b>PROGRAMMING</b> AIDS from Atari Assembler Editor Dembler (APX) Microsoft Basic Pascal (APX) Pilot (Consumer) Pilot (Educator) Programming Kit
<b>ADVENTURE INT</b> Scott Adams Adv No 1 Adventureland No 2 Pirate Adv No 3 Mission Imp No 4 Voodoo Cast No 5 The Count No 6 Strange City No 7 Mystery Fun No 8 Pyramid of D No 9 Ghost Town No 10 Saw Island 1 No 11 Saw Island 2 No 12 Golden Voy Angle Worms Deflections Galactic Empire Galactic Trader Lunar Lander	<b>AUTOMATED SIMULATIONS</b> Crash Crumble Cmp Datesones of Ryn Dragons Eye Invasion Orion Rescue at Riget Ricochet Star Warrior Temple of Apsah Upper Reaches Aps	<b>BOOKS</b> Basic Ref Manual Computs Atari DOS Computs Bk Atari Computs Magazine De Re Atari DOS Utilities List DOS2 Manual Misc Atari Books Op System Listing Wiley Manual	<b>EDUCATION</b> from APX Conv French Conv German Conv Italian Conv Spanish Energy Car European C & Caps Hangman Invt To Prog 1/2/3 Kingdom Music Composer	<b>EDUCATION</b> from ATARI Conv French Conv German Conv Italian Conv Spanish Energy Car European C & Caps Hangman Invt To Prog 1/2/3 Kingdom Music Composer	<b>ENTERTAINMENT</b> from APX Alien Egg Anhill Attack Avalanche Babel Blackjack Casino Block Buster Block 'Em Bumper Pool	<b>ENTERTAINMENT</b> from ATARI Asteroids Basketball Blackjack Centipede Chess Entertainment Kit Missile Command Pac Man Space Invaders Star Raiders Super Breakout Video Easy!	<b>ON LINE SYSTEMS</b> Crossfire Frogger	<b>PERSONAL INT</b> from APX Adv Music System Banner Generator Blackjack Tutor Going To The Dogs Keyboard Organ Morse Code Tutor Personal Fitness Prg Player Piano Sketchpad	<b>SANTA CRUZ</b> Basics of Animation Bots Business Display Lists Graphics Machine Kids 1 & 2 Horizontal Scrolling Master Memory Map Mini Word Processor Page Flipping Player Missile Gr Player Piano Sounds Vertical Scrolling	<b>SILICA CLUB</b> Over 500 programs write for details	

# FOR FREE BROCHURES - TEL: 01-301 1111

To free brochures and reviews on our range of electronic products, please telephone 01-301 1111. To order by telephone, just quote your name, address, credit card number, and order requirements and leave the rest to us. Post and packing is FREE OF CHARGE in the UK. Express 24-hour delivery available at an additional charge.

- SHOP DEMONSTRATION FACILITIES** — we provide full facilities at our shop in Sidcup, Monday to Saturday 10am to 5.30pm (closing Thursday 1pm, Friday 5pm)
- MAIL ORDER** — we are a specialist mail order company and are able to supply goods direct to your door.
- MONEY BACK GUARANTEE** — if you are totally unsatisfied with your purchase, you may return it to us within 15 days. On receipt of the goods in satisfactory condition we will give you a full refund.
- PART EXCHANGE/SECOND HAND MACHINES** — we offer a part exchange scheme to trade in many makes of TV games for personal computers.
- COMPETITIVE PRICES** — our prices, offers and service are very competitive. We are never knowingly undercut, and will normally match any lower price quoted by our competitors.
- HELPFUL ADVICE** — available on the suitability of various computers.
- AFTER SALES SERVICE** — available on all computers out of guarantee.
- VAT** — all prices quoted above include VAT at 7%.
- CREDIT FACILITIES** — we offer credit over 12, 24 or 36 months, please ask for details.

### SILICA SHOP LIMITED

Dept. CSVG 0483, 1-4 The Mews, Hatherly Road, Sidcup, Kent DA14 4DX.  
Telephone 01-301 1111 or 01-309 1111.

# SILICA SHOP

### FREE LITERATURE

I am interested in purchasing an Atari 400/800 computer and would like to receive copies of your brochures and test reports as well as your price list covering all of the available Hardware and Software:

Name

Address

Postcode

ICVG 0483 Computer & Video Games April 1983

## IMAGIC DEMON FACES NEW ONSLAUGHT

### LEGAL ATTACK

Established top seller Demon Attack is coming under fire in the US courts for being too similar to a cartridge Atari have still to bring out.

Atari-compatible cartridge producers, Imagic launched their range with the space game, Demon Attack. It is a top seller, both here and in the U.S. and recently became 1982 home video game of the year.

Atari claims that the cartridge is a copy of Phoenix which they are planning to release in home video form under licence from Centuri.

The notion of post-dated copyright is explained by Atari chairman Ray Kassar in the U.S. trade magazine Play Meter: "The relative success of Demon Attack in the market confirms to us the number of avid Phoenix fans who are buying Demon Attack to play Phoenix."

"With Atari's introduction of the authentic game, the presence of Demon Attack in the marketplace is confusing to the consumer."

Atari hopes to win an injunction against further sales of the game. The U.S. giant is also seeking an injunction against Colecovision Atari Expansion Module, which will allow Colecovision owners to play Atari software on their machine.



## CHEF IS IN A PICKLE!

### M NETWORK

Peckish? Then lick your lips because its Burger Time.

A nice thick 'n' juicy quarter pounder with all the trimmings is enough to satisfy the largest of appetites and also provide hours of scrumptious entertainment on your Atari VCS.

It's based on the hit arcade game and you play the harassed chef running through the multi storey maze trying to assemble the ingredients for your super-burger.

The good guys in this culinary caper are the seeded buns, the

meat patties, the lettuce leaves and the pepper — but watch out for the menacing sausages who have legs and are out to get your little chef, the pickles too can spoil your burger.

The way to deal with these unwanted morsels is to crush them by dropping burgers on them or stun them with a quick shake of the pepper pot. When you have assembled your burger you can go on to the next wave.

Burger Time is one of the new M Network of games from Mattel, the makers of the Intellivision machine, for the Atari VCS.

The games are due to go on

sale in the 'late spring' or 'early summer' although delivery dates are notoriously flexible in the video games business.

If we are not too certain about the "when" of these games we at least know a little bit more about the "how much" and there is some good news to report here.

Mattel are set to raise the competition's eyebrows with prices starting as low as £10.95 and going up to £19.95.

Other highlights of the M Network include versions of the hit Intellivision games Lock n' Chase, Tron Deadly Discs, Advanced Dungeons and Dragons and Star Strike.

Competition for Atari's Soccer cartridge is provided by International Soccer with a pitch which scrolls up and down the screen. Two space shoot outs are featured in the shape of Space Attack and Astroblast.

Loco-Motion challenges you to frenziedly build a rail system before the train arrives and crashes killing the passengers.

Six original games written just for the M Network include Dark Cavern, a Berzerk type game, the Adventures of Tron, a classic adventure game called In Search of the Golden Skull, a tank attack



game for two players called Armor Ambush, Frogs and Flies — similar to the Intellivision game Frog Bog, Air Raiders and Computer Revenge, in which you defend Earth from a barrage of alien missiles.

Intellivision owners will also be able to play Burger Time as Mattel are producing a version of the game for their own machine which will go on sale in the U.S. later this year.

This will also eventually be available in the UK though probably not until the end of the year.

## PICK-AXE PETE HUNTS FOR GOLD

### PHILIPS 6700 VIDEOPACS

Philips 6700 owners can look forward to two new Videopacs this month introducing Pick Axe Pete and a new chess challenge.

Pick Axe Pete hopes to strike it rich in the Misty Mountains. There's gold in them thar hills and Pete intends to be the man to find it.

You can join him on his adventure as he seeks the gold — leaping over bouncing boulders, finding hidden keys to get through locked doors, and climbing up ladders which have the

dangerous habit of disappearing from time to time.

Chess fans have also been included in this month's releases with six skill level chess challenge.

One of the six levels is a simulation of tournament chess. The computer imposes a time limit for its moves. An interesting feature is that you can follow the thinking process of the computer on your screen. You play by keying in the co-ordinates of your moves.

Videopac Chess complies with all the major rules of chess, including castling, promotion, capturing *en passant* etc. If you make an illegal move, the computer will refuse to execute it.

Other good news for Philips games fans is that the big American manufacturer Imagic are about to launch two of their best selling titles — Demon Attack and Atlantis for the G7000.

Prices have yet to be confirmed, the games will be in the shops before the end of April.

# SCENTRES TV GAMES CENTRES TV GAMES CENTRES VIDEO SCREEN

## VIDEO REVOLUTIONARY

### VECTREX

The first "all in one" video games system is about to go on sale the UK. Called the Vectrex it is manufactured by giant U.S. toy firm Milton Bradley, the people who brought you Dark Tower and Big-Trak.

The machine's main selling point is the TV style monitor which comes with the more usual games consol — so you don't need a TV to play.

The monitor is small and nicely designed, with a nine inch screen. Compact, with an absence of wires and leads, the Vectrex takes its name from the Vectre graphics screen, a hi-res display system incorporated in some arcade games like Asteroids and Tempest.

This graphics system represents all shapes as geometrical line drawings which shine out of the screen very brightly.

This means the Vectrex version of Asteroids — which is called Mine Storm — is a most accurate simulation of the arcade original.

Although this is fine for Asteroids fans like myself the graphics system is very limited when it comes to representing other types of games.

Hyper-chase for example, which is a scrolling screen car chase game, had very unconvincing graphics compared with similar games on the Intellivision and Colecovision.

Again on the minus side, the Vectrex only has black and white screen displays although transparent screen-overlays are supplied with each game to simulate colour — none too effectively in my opinion.

Although some of the games had disappointing graphics they still played well. Vectrex Scramble recreates all the addictiveness of this popular arcade game with authentic sound effects.

Rip-Off is a gem of a game incorporating some elements of Defender. You patrol a hexagon shaped space sector containing several diamond-shaped ships which the aliens attempt to dash in and steal. I played this one for over an hour!

A very neat arcade style controller is a strong point of the Vectrex. A responsive, if a little bit small, the joystick is mounted on a plinth with four buttons for



This is the Vectrex, the first "all-in-one" video games system.

other movement and, of course, fire commands.

The Vectrex will go on sale in May at around the £140 mark. You get the Mine Storm game as an added bonus.

The company is currently negotiating with high street shops Dixons and Greens so you won't have to travel far to buy one! Twelve games will be available at £19.95 each.

About 30 cartridges will be

available for the Vectrex by the end of 1983.

As well as new games these releases will also include some educational cartridges although no information is available about these as yet.

The news is not quite so good on the independent software front as people like Imagic and Activision have not announced plans to support the Vectrex as yet.



## MORE ON THE STICKS

### POINTMASTER

The Discwasher Pointmaster is the latest addition to the bewildering range of gourmet joy sticks now coming into the U.K.

I was slightly put off by the flimsy plastic construction of the stick. I couldn't imagine it standing up to my bad tempered style of play — being thrust down in anger when I lose my last Pacman ten points away from my high score.

However, for responsiveness the stick scored as highly as

either of the Wico sticks featured in last month's C&VG tests.

The fire button was sharp but a little heavy, clicking unnecessarily every time you released a missile.

Pricewise the Pointmaster is a good buy, retailing at £14.95 — a good ten pounds cheaper than the Wico sticks.

New products in the pipeline from Discwasher include a rapid fire button, an up graded Pointmaster, a software disc-drive and cassette recorder cleaning kit.

1 Pacman	Atari VCS	Atari
2 Defender	Atari VCS	Atari
3 Space Invaders	Atari VCS	Atari
4 Starmaster	Atari VCS	Activision
5 Frogger	Atari VCS	Parker Brothers
6 Demon Attack	Atari VCS	Imagic
7 Star Raiders	Atari VCS	Atari
8 Empire Strikes Back	Atari VCS	Parker Brothers
9 Berzerk	Atari VCS	Atari
10 Pitfall	Atari VCS	Activision

# For the best hardware, the best software.

The BBC Microcomputer system is generally regarded to be the best micro in its price range you can lay your hands on. So, if you're thinking of buying one or already own one, you'll want to know about the software that's been specially designed for it.

Not surprisingly, it's made by Acornsoft, the software division of Acorn Computers Ltd., who designed and built the BBC Microcomputer. So naturally you can expect the highest quality software with the built-in ingenuity to fully exploit the BBC Micro's potential.

## Further education for everyone.

Tree of Knowledge (£9.95) is an interactive program for children of all ages teaching categorisation. It illustrates some of the more practical aspects of computing in that the pupil first educates the computer, building up a database by answering the computer's questions, and the database is then used to play games of deduction and logic.

Word Hunt (£11.90) is a set of four programs, each containing a list of nine words. The object of the exercise is to select one word and then try to create as many smaller words as

possible from the selected word.

## Increase your business acumen.

Graphs and Charts (price £17.45) which includes the book 'Graphs and Charts on the BBC Microcomputer' contains a set of programs

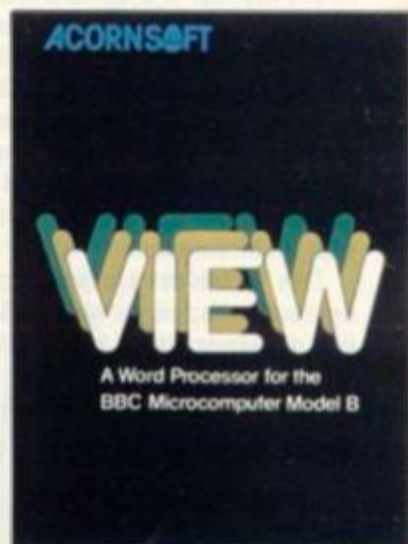
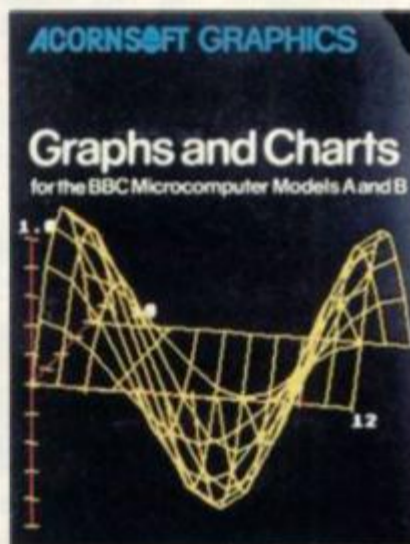

to present data graphically in a wide range of applications. The graphs include automatic scaling, labelling of axes and use of colours.

And VIEW (price £59.80) a program that enables your machine, together with a printer, to operate as a fully operational word processor. For convenience the program is in ROM so that it can become a permanent feature of your machine. (It can easily be fitted by your local dealer). You'll find out more by going to your dealer or by sending for the free catalogue.

## Mind-boggling games.

Castle of Riddles (price £9.95) is a magical adventure, with wizardry and hocus pocus of all kinds; booby traps and fiendish riddles to be unravelled along the tortuous route to the Magic Ring of Power. Your reward is to keep the

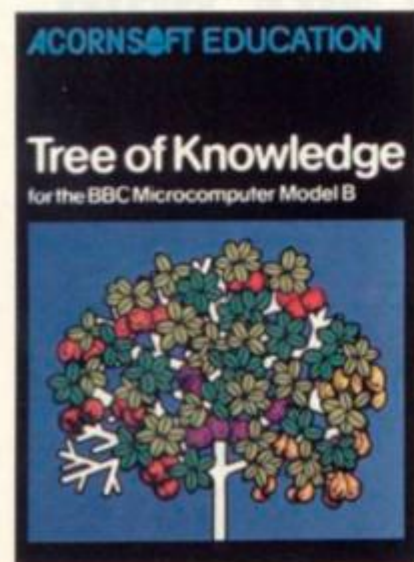

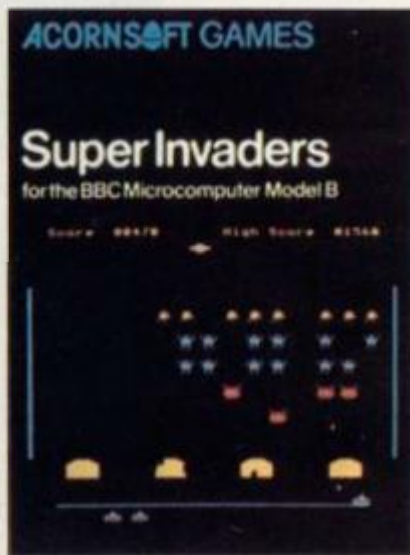
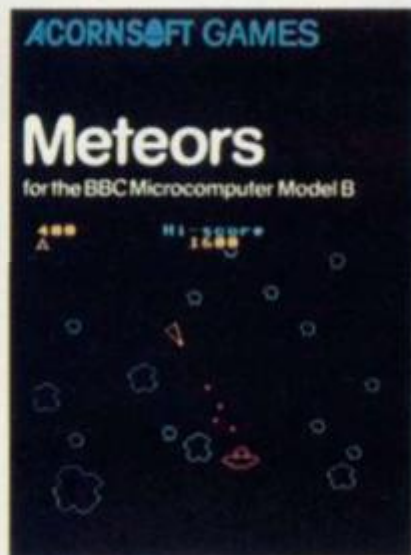
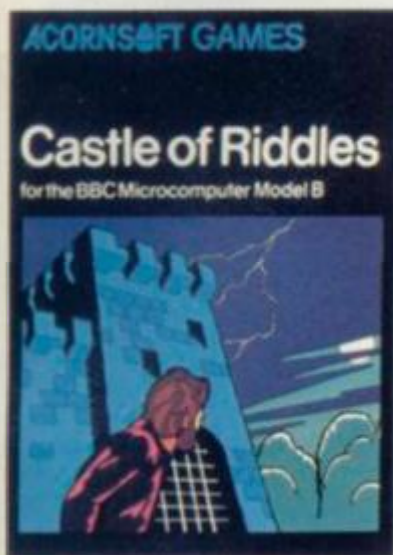

### How to get Acornsoft programs.

If you're a credit card holder and would like to buy cassettes of the programs shown in this advertisement, or if you would like to know the address of your nearest stockist, just phone 01-200 0200.

Alternatively, you

treasure you find along the way.

Meteors (price £9.95) is a game where you have to manoeuvre your laser-ship through a hail of meteors, smashing them with your laser bolts as they hurtle towards you on all sides. Complete with sound effects and table of Hi-Scores.

Super Invaders (price £9.95) is a fight against invading aliens. The only way to resist and avoid subsequent annihilation is to destroy the aliens before they land. You have three mobile launchers whose hyper-velocity missiles will instantly vaporise their target on impact. This game includes high-score, and is fully compatible with either keyboard or joysticks.

### Understanding computers.

Peeko-Computer (price £9.95) simulates the operation of a simplified microcomputer in order to teach the fundamentals of machine-code programming. It comes complete with a 16 page instruction manual including exercises and examples, and the cassette features five demonstration Peeko-Computer programs.

can buy the cassettes directly by sending off the order form below to: Acornsoft, c/o Vector Marketing, Denington Estate, Wellingborough, Northants NN8 2RL.

Also use this form if you would like to receive the current free Acornsoft catalogue.

Please allow 28 days for delivery.

 Credit Card Holders. Telephone 01-200 0200.

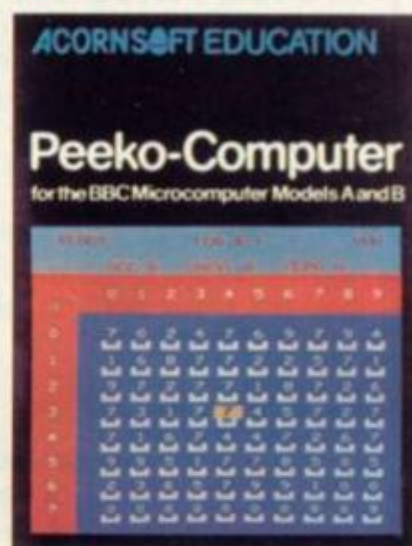

To: Acornsoft, c/o Vector Marketing, Denington Estate, Wellingborough, Northants NN8 2RL.

Please send me the following:-

PROGRAM	PRICE	QUANTITY	TOTAL	(Code Acornsoft use only)
Tree of Knowledge	£9.95			SBE04
Word Hunt	£11.90			SBE05
Graphs & Charts	£17.45			SBX02/SBD002
Castle of Riddles	£9.95			SBC17
Meteors	£9.95			SBC13
Super Invaders	£9.95			SBC16
Peeko-Computer	£9.95			SBE02

TOTAL

I enclose PO/cheque payable to Acornsoft Ltd. Or charge my credit card.

Card Number \_\_\_\_\_

(Amex/Diners/Visa/Access/Delete)

Please send me the Acornsoft brochure

Please send me the VIEW catalogue

Name \_\_\_\_\_

Address \_\_\_\_\_

Postcode \_\_\_\_\_

Signature \_\_\_\_\_

CVG4

Registered No. 1524763

VAT No. 215 8123 85

# ACORNSOFT



## Dragon's Lair

I thought it would be easy... explore the Dragon's Lair and find the Crystal of Power with which to destroy him. But I didn't count on the dangers that confronted me. There were others in that mind boggling maze too! The ultimate 3D Maze Adventure for the 48k ZX Spectrum.

## Joust

It's taken America by storm — now its available for your ZX Spectrum! In this amazing new arcade game you Joust with the Dark Lords in an other worldly setting. Quite amazing animation as you fly your Ostrich by controlling the flap of its wings!

## MONSTERS IN HELL

It was like a nightmare. Trapped in Hell, the all consuming flames below me, running from the Vampire monsters through a maze of platforms and ladders. I had Holy Power on my side, though, and could survive if I replenished it frequently. And the only way to kill them was to make them fall through holes I created with my hammer. But then the Mad Monk sent his ghouls after me... Any ZX Spectrum.

## MILLIPEDE

Milli the Millipede seemed indestructable; no matter how much of her body I shot away she kept coming! But then Sid the Spider appeared from nowhere, and Scorpi zoomed across dropping her indestructable fleas on me! A quite astounding version of the arcade favourite. £5.95.

## COSMIC SWARM

OK, I accept I'm to blame. I disregarded orders and entered the Altair sector. Eggs, eggs everywhere — I shoot, two fantastical alien types appear whose touch is deadly! They join, seemingly by chance, into a mutant which chases me! Probably the most original new space 'shoot-em-up' game to appear. Any ZX Spectrum.

## FIREBIRDS

They swoop, they dodge, they loop figures of eight! Can you survive the Firebirds' attack? Amazing hi-res machine code action from the masters. Any ZX Spectrum.

## ALSO AVAILABLE

And you can still obtain our outstanding Meteoroids, still the best available, or our Zolan Adventure, still the only truly, playable 16K Adventure!

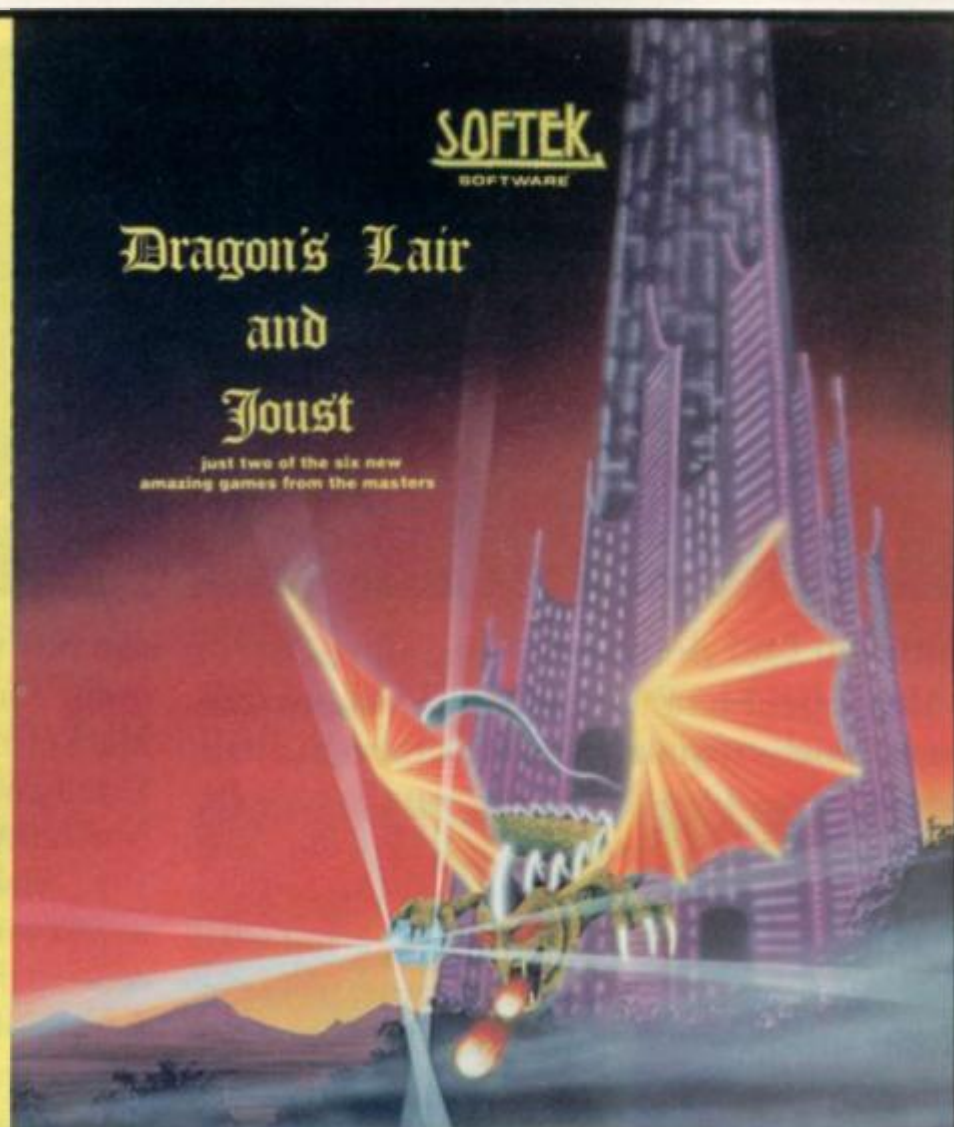

**EACH GAME JUST £5.95**

including VAT, postage and unconditional guarantee. All games in 100% machine code. Available from all good shops, or if they are out of stock, direct from us by return of post — please make out your cheque/P.O. to Softek.

# SOFTEK

SOFTWARE

**SOFTEK SOFTWARE,  
329 CROXTED ROAD,  
LONDON SE24**

## ZX SPECTRUM SOFTWARE



# CHESS



Artificial Intelligence research is closely linked to chess programming in trying to help computers think like we do.

Researchers at Edinburgh University have subjected the King and Rook against King and Knight ending to detailed analysis to try and come up with a database giving the result and best move in every legal position.

Grandmasters usually believe the ending to be a draw but it is so complicated to play that in practice this is seldom the case.

King and Rook versus King and Knight endings (KRKN) would seem to be impossible task for the programmer trying to give his computer the best option every time.

At first sight, generating such a database is a hopeless task. Assuming that each player has an average of 10 moves in every position, there would be over 10 to the power 50 different variations to consider (up to the end of the game) before deciding on the best move in some positions.

However, the amount of computation involved can be hugely reduced by a well-established trick. This involves generating all the positions which are won for White (the side with the Rook) by working backwards from *terminal wins* — checkmates. All positions not generated by this process are drawn, except for a few positions where the Knight gives checkmate for Black!

As an example, figure 1 shows Black to move, checkmated or, in the jargon, *lost at depth zero*.

Incidentally, it is helpful fiction to consider positions where White has just taken Black's Knight without leaving the Rook *en prise* or giving stalemate as "checkmates". Any position from which White to move can legally play figure 1 must be a win in one move (i.e. at depth one).

Figure 2 is such a position with White to move, since White can now choose to play R-QR2 mate. Generating all checkmate positions (Black to move) is reasonable straightforward. Retracting every (legal) White move from each of those gives all *win at one ply* positions (White to move). There are between two and three million of these altogether, including figure 2.

Now consider reversing every possible last Black move in figure 2. Supposing Black last played his Knight from KN5 to KN3, then the previous position was figure 3.

Checking every legal Black move from this position reveals that each one plays to a *lost in one ply* position (such as figure 2 or figure 4).

Hence, figure 3 can be classified as

lost in two ply with Black to move. Working backwards a further step shows that figure 5 (with White to move) is a win for White in three ply, since White can choose to play R-QNZ giving figure 3.

Continuing in this way (with a few embellishments) eventually produced the desired list of all won positions, together with the depth of the longest winning variation and the best move for the side to move.

What makes the algorithm almost unworkable in practice is the huge number of possible positions even with only four pieces on the board.

Fortunately, the number can be greatly reduced making use of symmetry. For example, figure 6 is the same as figure 5 symmetrically, if the latter is imagined reflected about a vertical line between the two middle files of the board.

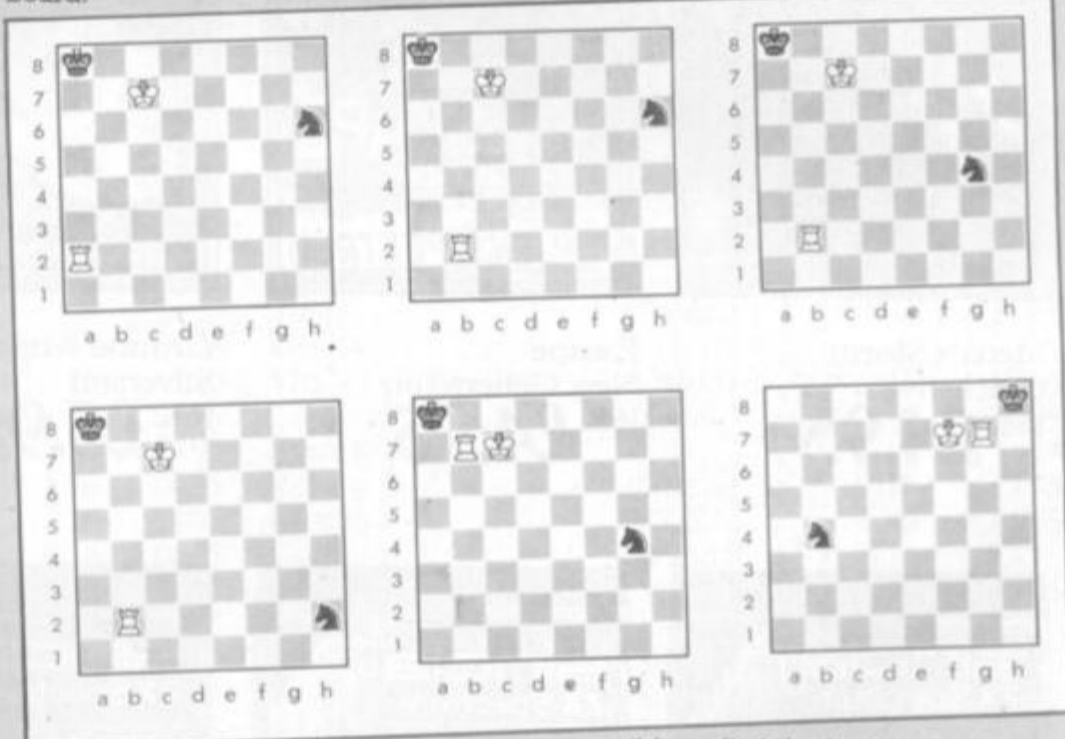

Hence, figure 6 must also be a win for White in three ply.

It turns out that it is only necessary to consider positions with the Black King on one of a set of 10 squares, such as QR1, QN1, QB1, Q1, QN2, QB2, Q2, QB3, Q3, Q4.

Moreover, there are only 462 legal King configurations with the Black King restricted to this triangle of squares (deleting cases where the two Kings are adjacent or on top of one another).

This allows the number of positions it is necessary to consider to be reduced to  $462 \times 64 \times 64 = 1,892,352$  with each side to move, many of which are illegal because of the position of the Rook or Knight. All other positions are equivalent to these by symmetry.

This is still a large number of course but manageable with a large computer.

Working at Bell Laboratories, Ken Thompson (the inventor of BELLE) has produced a database giving the necessary information for the 651,492 of these positions which are wins with White to move.

Thompson has also produced a table showing the number of won positions for White (to move) where it takes 1, 2, 3 ... moves to give checkmate (or safely take the Knight).

There are 378,518 essentially different mates in one, allowing for symmetry, 95,450 mates in two and so on down to the deepest wins of all: two positions where White moves in 27 moves (53 ply).

For the record, these two positions are: a) WK on QR6, WR on KR3, BK on QBL, BN on QN5, and b) WK on Q8, WR on KR8, BK on QN1, BN on KN4.

By using Thompson's database, it is

possible to find the best move in every winnable KRKN position — a remarkable achievement, yet profoundly dissatisfying.

The problem is solved but in a form which no human could possibly remember or understand.

The natural question to ask is whether the content of this huge database could be simplified down to a relatively few rules of play of the kind usually found in textbooks.

If it could, the resulting rules would have the merits of high precision (rather than the general advice, such as "try to separate the King and Knight" given in books) and guaranteed reliability.

Recent research has concentrated on synthesising just such rules, in a form which human chess players find is meaningful. I will return to this topic in a future article.

BY MAX BRAMER

# You know that Spectrum software is easily affordable.

## Now W.H.Smith make it easily available.



Meteor Storm  
Quicksilva  
16K **£4.95**

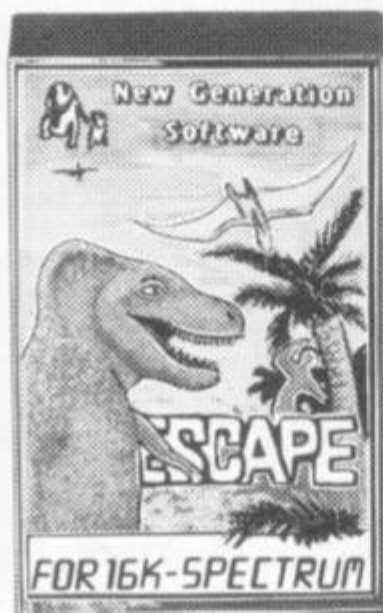

Escape  
New Generation  
16K **£4.95**



Ground Attack  
Silversoft  
16K **£5.95**

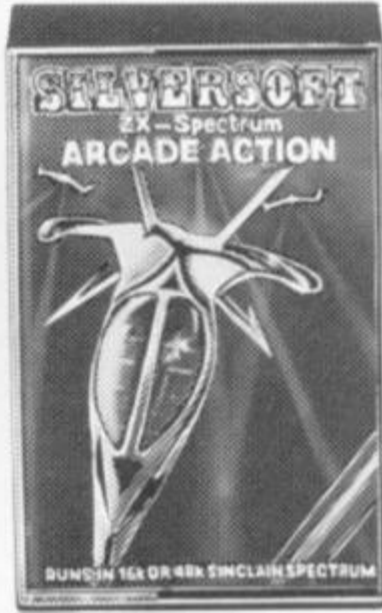

Orbiter  
Silversoft  
16K **£5.95**



Space Raiders  
Sinclair  
16K **£4.95**



Flight Simulation  
Sinclair  
48K **£7.95**



Horace Goes Skiing  
Sinclair  
16K **£5.95**



Battle of Britain  
Microgame  
48K **£5.95**

When it comes to software for the Sinclair Spectrum, there's no question who's right up your street. W. H. Smith.

Our range already covers some 65 programs. And it's growing fast.

So fast that every month we select and illustrate a Top Ten to

### W. H. Smith Spectrum Software Library

(all 16K programs will run on 48K machines)

Title	Producer	K RAM	Price
<b>Arcade Games</b>			
Space Intruders	Quicksilva	16	£4.95
Time Gate	Quicksilva	48	£6.95
Mined Out	Quicksilva	48	£4.95
Gulpman	Campbell	16	£4.95
Spectral Invaders	Bug-Byte	16	£5.00
Avenger	Abacus	16	£4.95
Meteoroids	Softtek	16	£4.95
Planetoids	Sinclair	16	£4.95
Hungry Horace	Sinclair	16	£5.95
Mazeman	Abersoft	16	£4.95
Nightflight	Hewson	48	£5.95
Ground Force Zero	Titan	16	£5.00
Caterpillar	CDS	16	£5.95
Leapfrog	CDS	16	£5.95
Gobble-A-Ghost	CDS	16	£5.95
Centi-Bug	DK Tronics	16	£4.95
3D-Tanx	DK Tronics	16	£4.95
Penetrator	Melbourne Hse	48	£6.95
Cruising	Sunshine	16	£4.95
Arcadia	Imagine	16	£5.50
Derby Day	Computer Rentals	16	£5.95
Jackpot	Computer Rentals	16	£4.95
3D-Tunnel	New Generation	16	£4.95
Gobbleman	Artic	16	£4.95
Galaxians	Artic	16	£4.95
Sentinal	Abacus	16	£4.95
Cyber Rats	Silversoft	16	£5.95
<b>Strategy Games</b>			
Novotnik Puzzle	Phipps	16	£4.95
Chess	Artic	48	£9.45
Voice Chess	Artic	48	£9.95
Football Manager	Addictive	48	£6.95
Chess-The Turk	Oxford	48	£8.95
<b>Adventure</b>			
Labyrinth	Axis	16	£5.95
Planet of Death	Sinclair	48	£6.95
Inca Curse	Sinclair	48	£6.95
Ship of Doom	Artic	48	£6.95
Espionage Island	Artic	48	£6.95
The Orb	Computer Rentals	48	£5.95

keep you informed of the programs which are proving to be the most popular.

If on the other hand you've already got the Top Ten then why not come in and browse through the rest of our range.



Chess  
Sinclair 48K  
**£7.95**

The Hobbit  
Sinclair 48K  
**£14.95** Double Tape plus book

Title	Producer	K RAM	Price
<b>Utility</b>			
M/C Code Test Tool	Oxford	16	£9.95
Compiler	Softtek	16	£14.95
<b>Family Games</b>			
Reversi	Sinclair	16	£7.95
Othello	CDS	16	£5.95
Golf	R and R	16	£3.75
Conflict	Martech	48	£11.95
<b>Practical</b>			
Vu-Calc	Sinclair	16	£8.95
Vu-File	Sinclair	16	£8.95
Vu-3D	Sinclair	48	£9.95
Collectors Pack	Sinclair	48	£9.95
Club Record Controller	Sinclair	48	£9.95
Address Manager	Oxford	16	£8.95
Dietron	Custom Data	16	£4.75
<b>Program Collections</b>			
Shiva Special 1	Shiva	16	£5.95
Over The Spectrum 1	Melbourne Hse	16	£5.95
Over The Spectrum 2	Melbourne Hse	16	£5.95
Over The Spectrum 3	Melbourne Hse	16	£5.95

# WHSMITH



Prices correct at time of going to press. Subject to availability. At selected branches only.

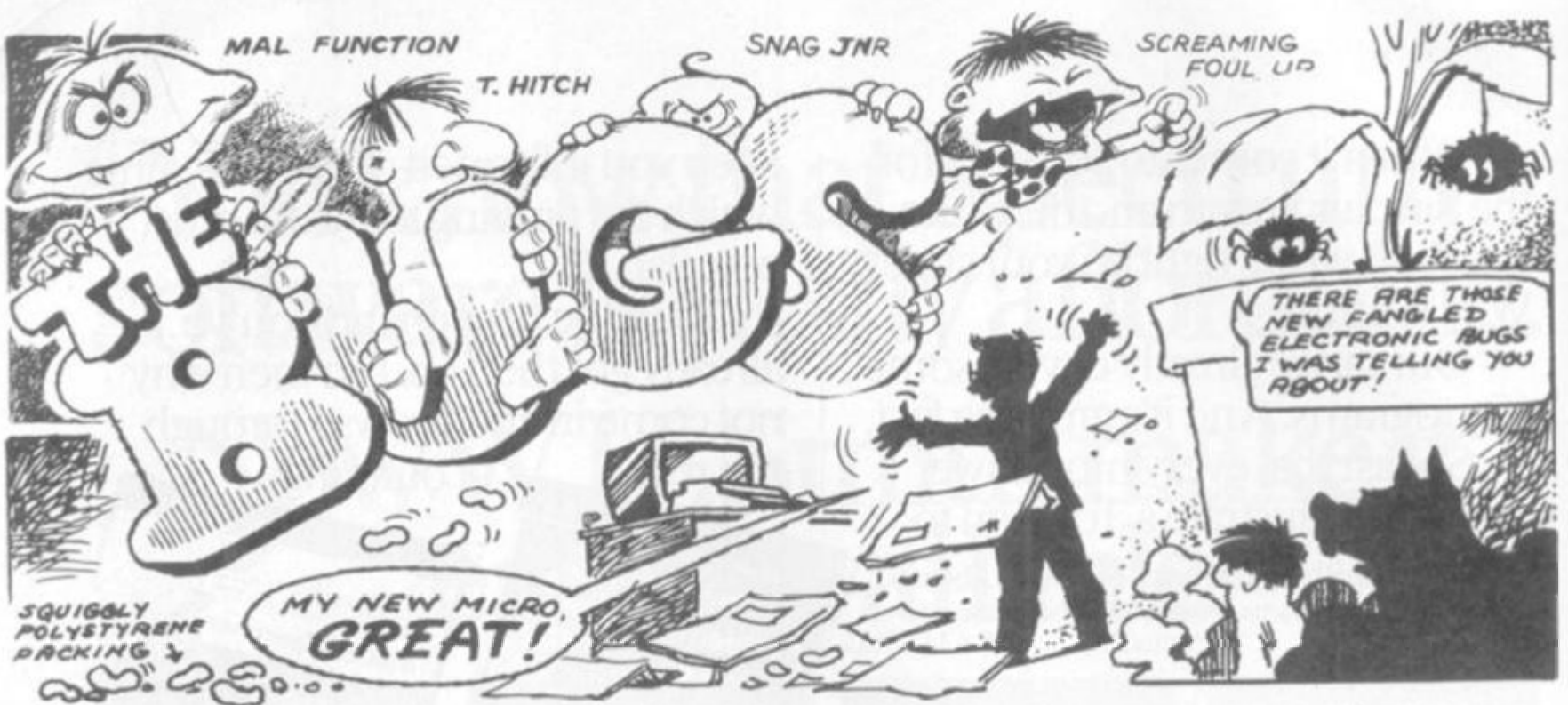

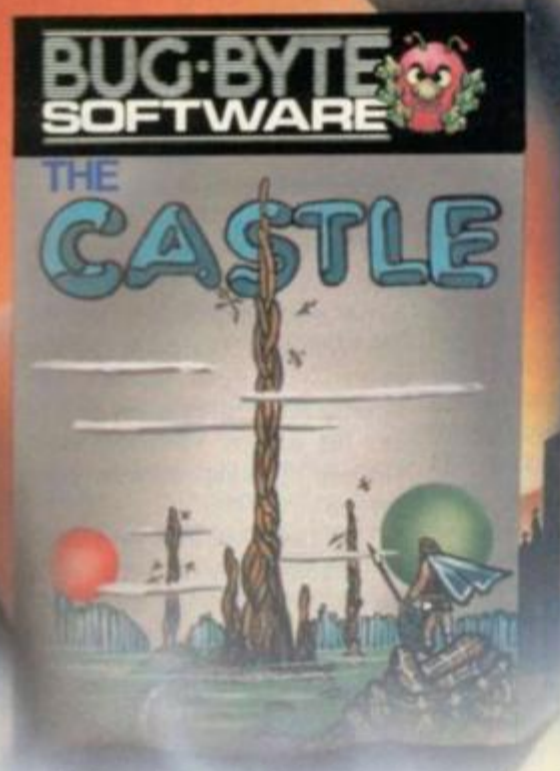

## BUG-BYTE SOFTWARE, MORE THAN A GAME ...IT'S A DOOR TO ANOTHER DIMENSION!

All about me was darkness. Tens of thousands of screens stared blankly into space. Minds drifted aimlessly, dulled by lack of stimulation. The world was grey, drab, lacking...

Then suddenly it happened. First one, then another, then tens, hundreds, thousands of tired screens felt a surge of power and flickered back into life. They were much as I had seen on my own planet's microcomputers - the ZX 81, ZX Spectrum, Vic 20, BBC Micro and ORIC-1.

The minds paused to take stock. They clustered round the screens, their nimble fingers excitedly flicking the controls back and forth. At last they had found a challenge... action

and adventure with cunning tests of dexterity and reaction. Everywhere, conversation was of Asteroids, Mazogs, Panic, Another Vic in the Wall.

Unable to resist, I too had a closer look. There before me was vivid colour, high resolution graphics. I could practically feel the spine-tingling sound effects as whole battle fleets of Cosmiads swarmed out of nowhere and attacked. I should have known. As my fingers raced over the controls, and I prepared to stand and fight with only a single laser bolt for protection, I realised I was trapped!

Too late now, I remembered this was no

ordinary software. I'd been warned, as I now warn anyone buying from Laskys, W.H Smith, Currys Micro C, Spectrum and larger branches of Boots, and a nationwide network of dealers stocking Bug-Byte. Because Bug-Byte is more than a game, it's a door to another dimension. One that I had opened.

**BUG-BYTE SOFTWARE** 

100 The Albany, Old Hall Street, Liverpool L3 3AB



# PINBALL

Baby Pac-Man leads you where no other video game or pinball has gone before!

So says the publicity material from Bally about their latest baby — an out and out arcade mutant!

At first glance this latest addition to the Pac-Family looks like an upright video cabinet — then you notice that there's a pinball playfield grafted on to the bottom. You get two flipper buttons — either on top or on the cabinet sides, just like a regular pin, plus a joystick controller for the video-maze.

Game action starts off in the Pacman maze with Pac-Baby munching his way around controlled by the stick. But there are no energisers to help fight the deadly ghosts. You must escape through the out-tunnels which lead to the pinball playfield. Here you earn the energisers and valuable fruits to enable you to score in the video-maze.

Spelling PACMAN by hitting drop targets earns you one energiser. Hitting the Hoop Loop ball spots earns you more. Spell FRUITS by hitting more targets and you get one of eight fruits. Spell TUNNEL and you'll increase your Pac-speed through the maze.

You get back into the maze by dropping your ball into one of the playfield's two saucers or when your ball drains away. Hitting the saucer will allow you an escape route to the playfield — but the "drain" closes the escapes and you'll have to beat the maze or be eaten to gain freedom of the machine once more.

You can earn an extra Baby by lighting up the centre arrows on the pinball playfield. The game begins and ends in the video-maze and you get three lives to play with.

It's yet another interesting innovation from Bally, and has been going down well in the U.S. and at trade fairs in this country. Watch out for it!

# FOUR GAMES IN ONE

## TIPS ON TRON

With a whole Walt Disney movie to work on, the designers of Tron — the video game were spoilt for choice in deciding what action to feature.

They got around the problem by offering four games in one. Each wave of Tron offers a challenge on every game. Two of these test reaction and co-ordination and two pattern-learning and recognition.

You can tackle the four games in any order but must go through all of them before starting a second wave.

A beginner should start with the easiest screen — which also offers the most points — Grid Bugs. These computerised spiders are to be blasted by Tron so he can reach the transporter, which will take him on to the

MCP's next testing challenge.

There is a time limit on this but use it all until the warning note sounds and you should net a nice total at 50 points a bug.

On wave one immediately blast your way to gain a position in front of a side entrance. On wave two, kill bugs directly above you before moving to the side entrance.

Wave three should be dealt with by moving to one side of the transporter and firing down on the bugs. Wave four comes in a figure "2" and Tron should escape right and up diagonally and blast through to the transporter's right entrance.

Wave five surrounds Tron with bugs. Fire to right as soon as they appear and escape in that direction.

The MCP Cone has to be blasted through while it descends upon you. Rise up through the cone firing continuously and escape into the upper part of the

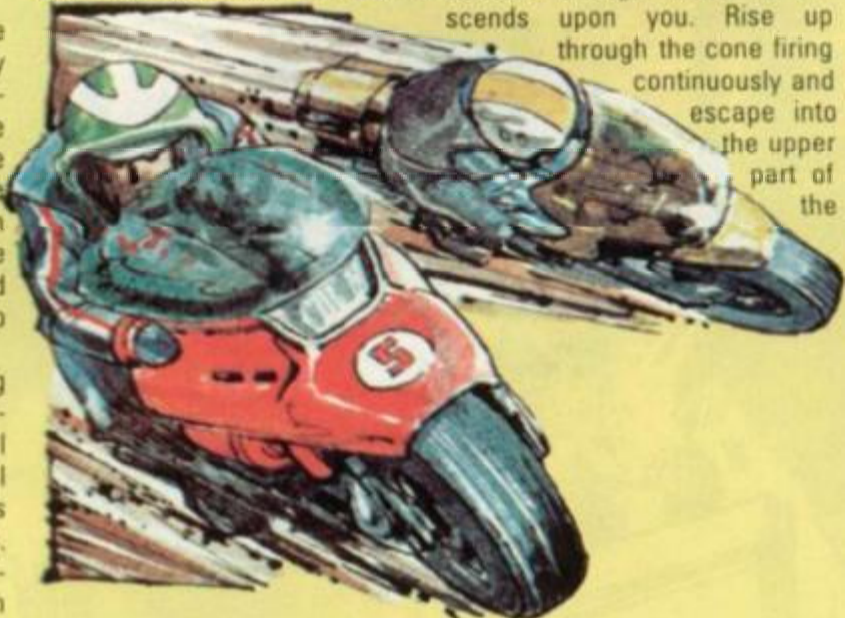

# EVIL EMPIRE ATTACKED!

## TAC-SCAN

A whole squadron is yours to command in Tac-Scan and a deadly evil galactic empire is the target.

Seven ships must be manoeuvred in the battles with the empire's own Annihilators and Stinger craft as laser beams flash across space.

A space warp tunnel will fling you into new areas of the galaxy and marvellous blue graphics on a black background, plus a real feel for perspective make this game more than just another space conflict.

Annihilators attack with rocket fire, Stingers aim lethal lasers while your Tac-Scan fighters can

be reinforced by new craft as the squadron is depleted. This is achieved by pushing the Add Ship button or docking with additional ships which occasionally appear on the screen.

Manufacturers Sega claim, "More than 1,300 realistic space sound variations" and "unique spiralling, twirling perspective views".

It's certainly light years from the sort of space conflict, the invaders offered and controlling a squadron, as opposed to just one craft offers new scope, problems and challenges.

cone. If any part of it or its blocks touch you, you will be de-rezzed.

You score 1,000 points for entering the cone without touching the blocks and a further thousand is available for clearing all blocks.

Advanced cone waves are made more difficult as the speed of rotation and speed of descent increases.

Light cycle screens are really a question of experimentation to get the right pattern to survive while the yellow light cycles destroy themselves.

This is similar to the popular computer game of Surround, except that you control your speed. Use a fast burst on the trigger early on to set up your pattern and then slow down to avoid destruction while the enemy cycles crash.

Remember that the enemy cycles react to your movement, so a pattern, once memorised by you will give the same results every time. Push joystick and throttle forward as soon as you see the screen. Then you know you are the right route for each screen.

The tanks screen is difficult with each enemy tank needing to be hit three times to destroy it. Your advantages lie in rapid fire and rebounding shots off the walls of the maze — plus a chance to learn from your mistakes.

Again get in the habit of pushing off full throttle as soon as the screen starts and memorise patterns. All patterns once learnt and practised can be repeated successfully.





## MEETING A STICKY END

### ANTEATER

The anteater collects termites by probing through their tunnels with his long sticky tongue. Most of these odd animals seem to thrive on this method of dining out — but there are hidden dangers below the surface which wary anteaters should watch out for.

This particular breed of ants are swallowed easily enough when approached in the right manner — but should they happen upon anything other than the end of the anteater's tongue they will just chomp their way through it.

You play the anteater in this game using a joystick for controlling your direction and a retract button for rushing back to defend against danger nearer your snout.

Your animal stands by an ant-

hole and sends his tongue down through a network of passages.

Other worries which live in these tunnels are worm which inch their way along carrying a noxious substance on their heads. These can only be eaten from behind.

Right at the bottom of the screen are the queen ants. These must be gobbled to kill all ants in the passageways. While you are busy gobbling, watch out for ants approaching along side passages and keep a wary eye out for worms. And beware, daylight is fading and the dreaded spiders will soon be out!

These will travel down your tongue on finding it and prevent retraction. When a spider is on your tongue, it's hell-for-leather down to the queen ants to try and save yourself.

## BOARD WITH ARCADES?

### BOARD GAMES

Just when we were used to seeing our arcade heroes turning up in TV games centres, game-watches, even movies, they have been launched in a new medium.

Now you can play Pacman — the board game. A range of six arcade board games has been launched by Milton Bradley and the first three out are: Pacman, Frogger and Donkey Kong.

A large board covered in beads is inhabited by four colourful plastic gobblers whose jaw mechanism allows them to swallow every bead they land on. Two ghosts also wander the board, trying to catch the Pacmen and retrieve the beads.

Going over an energiser bead

allows you to catch and eat the ghosts, sending them back to their home at the centre of the board.

When all the beads have been eaten, the Pacman with most in his tray is the winner. Energiser beads, four tunnels and of course, dice also feature in this simple recreation of arcade glut-tony — but I couldn't see any fruit!

Donkey Kong is also for four players, while Frogger challenges two players to be first across the road and river.

The games retail at around £9 and the series will be added to soon by Berserk, Defender and the 3D thrills of Zaxxon.

## DRIVE FOR REALISM

### POLE POSITION

Pole Position is simply the most exhilarating driving simulation game on the market.

Turbo featured better landscapes in its driving action but it can't match the speed, thrills and skill behind this new race game.

Your car is shown in front of you on the racetrack as you begin a qualifying lap. The countdown starts as soon as the lights flash, and away you go in first gear to try and beat the clock.

There are a few other drivers out to qualify as well and these may have to be overtaken at the end.

Cars turning corners are shown in every graphic detail of the manoeuvre. You must avoid them and the road signs or crash. Taking corners too quickly

will result in you losing control of the car. Skidding off the track, crashing or hitting oil puddles slow you down.

A time below 73 seconds will put your car into the race proper and your starting grid position depends on that time.

Jostling with the other cars in the race, you must also take on the clock to notch a top time on the machine.

An accelerator pedal, two gears and a steering wheel are your controls in this game which comes in stand-up cabinet and cockpit design.

Time, score, lap and speed are shown on screen. No unnecessary frills but the plain graphics are sophisticated and believable and trying to hold a screaming curve or overtake, offers thrills to compare with the real racetrack.

## "Q" UP FOR THIS ONE

### Q\*BERT

The lovable Q\*bert begins to play on top of a 3D pyramid of brightly coloured blocks and he has also topped America's video games charts.

The game theme is obvious and its simplicity makes it all the more infuriating when Q\*bert's mission ends abruptly.

With big eyes, a hollow-tube of a nose and not much else, Q\*bert hops down his pyramid changing the colour of every block he lands on. When every

block has been changed, the little creature hops off to start a new screen with a new pyramid.

The task is made more complicated by a series of bouncing characters who follow Q\*bert down the pyramid dislodging him if they meet. There is also a deadly snake called Coily who will follow our hero back up the screen and try to squash or bite him.

Coily comes down screen as a grape shape, pauses and sets off on Q\*bert's trail. To escape Coily, Q\*bert must make use of two flying discs beside the pyramid. A well-timed leap onto one of these will return Q\*bert to the pyramid top while sending Coily leaping off into space and instant death.

Subsequent levels require Q\*bert to change the grid to first one intermediate colour and then the object colour, by two leaps on every cube.

There are nine levels in all and the diagonal leaps are achieved by a four-way joystick.

It can be played by one or two people. Q\*bert seems to be an appealing creature, despite his habit of swearing a good deal, the graphics and colours are bright and extra Q\*berts can be won for scores ranging from 6,000 to 11,000. The machine operator sets the level.



**A** VAST landlubbers! This here's a tale of high adventure on the high seas in the time of Lord Nelson and his famous fleet. Splice the mainbrace and set sail for an encounter of the salty kind with the scurvy seadogs of the Spanish navy.

Battle commences when the English ships of the line meet the Spaniards. English ships are shown on the right of the screen as inverse W, X, Y, and Z. The Spaniards are represented by inverse A, B, C and D.

The border around the playing area is marked out by x's which represent rocks and the graphic '+' represents wrecks. If you hit the border or a wreck then your ship will sink.

When a ship is hit by gunfire it gets a damage rating. Any ship sustaining a damage factor of more than seven can only move one space at a time in the direction required. When a ship's damage factor reaches more than nine it will sink.

The wind direction — which governs the move-



ment of ships — can change at random. A ship cannot move against the wind and will travel further with the wind than at a tangent to it.

Some instructions and

input prompts are displayed at the bottom of the screen during play. For example: what ship to move, damage factor for a ship etc.

Cannons are fired by

using key '9'. Each ship in turn can fire before moving. Fire is always at ninety-degrees to the direction of travel. If an enemy ship is hit it will fire back automatically.

# TRAFALGAR

BY PAT NORRIS

RUNS ON A ZX81 IN 16K

```

3 LET P=PEEK (16396) + 256 * PEEK
(16397)
4 LET AC=1
5 LET EEF=4
6 LET SSF=4
9 FOR G=1 TO 32
10 PRINT "X";
15 NEXT G
20 FOR H=1 TO 14
25 PRINT "X
X"
30 NEXT H
35 FOR I=1 TO 32
40 PRINT "X";
45 NEXT I
50 PRINT "WIND=
1
55 PRINT "SHIP= COURSE= DAMA
GE= 0 2
60 PRINT TAB 25;"7 X 3"
65 PRINT "INPUT COURSE(0 TO 7)
OR 6 4"
67 PRINT "9 TO ATTACK";
68 PRINT TAB 27;"5"
76 POKE P+115,21
80 POKE P+207,21
82 POKE P+287,21
84 POKE P+379,21
90 DIM Q(8)
95 DIM S(8)
100 DIM L(8)
105 DIM C(8)
110 LET A=166

```

```

120 LET D=135
125 LET E=1
130 LET S(E)=A
135 LET L(E)=D
140 LET C(E)=3
142 IF E>4 THEN LET C(E)=7
145 LET Q(E)=0
150 POKE P+L(E),S(E)
160 LET E=E+1
165 IF E>8 THEN GOTO 205
170 IF E=5 THEN GOTO 190
175 LET A=A+1
180 LET D=D+66
185 GOTO 130
190 LET A=A+19
195 LET D=D-171
200 GOTO 130
205 LET W1=1
210 LET F=1
215 LET W=INT (RND*8)
217 IF F>8 THEN LET F=1
219 IF Q(F)>9 THEN GOSUB 2000
220 IF Q(F)>9 THEN LET S(F)=0
221 IF S(F)=0 THEN LET F=F+1
223 IF F>8 THEN GOTO 217
224 IF S(F)=0 THEN GOTO 217
225 IF AC>1 THEN GOTO 228
227 LET AC=1
228 GOSUB 500
230 GOSUB 920
231 IF M=9 AND AC=1 THEN LET XX
= F
232 IF M=9 AND AC=1 THEN

```



```

GOTO 600
233 IF M=9 AND AC>1 THEN GOTO 2
30
235 IF M=0 AND C(F)=6 THEN GOTO
250
236 IF M=6 AND C(F)=0 THEN GOTO
250
237 IF (M=1 OR M=0) AND C(F)=7
THEN GOTO 250
238 IF (C(F)=0 OR C(F)=1) AND M
=7 THEN GOTO 250
245 IF ABS (M-C(F))>2 THEN GOTO
230
250 LET R=3
252 LET AC=1
254 IF ABS (M-U)=3 THEN LET R=4
256 IF ABS (M-U)=5 THEN LET R=4
258 IF ABS (M-U)=4 THEN LET R=5
260 IF Q(F)>6 THEN LET R=2
262 IF Q(F)>7 AND Q(F)<10 THEN
LET R=1
264 IF M=U THEN LET R=0
269 IF R=0 THEN GOTO 405
270 POKE P+L(F),0
277 LET C(F)=M
280 LET MU=0
282 LET X=0
284 IF M<3 THEN LET MU=MU-(34-M)
)
286 IF M=4 OR M=5 OR M=6 THEN L
ET MU=MU+(38-M)
288 IF M=3 THEN LET MU=MU+1
290 IF M=7 THEN LET MU=MU-1
295 LET SX=1
300 LET X=PEEK (P+L(F)+(MU*SX))
315 IF X=21 OR X=61 THEN GOTO 3
31
320 IF X>165 THEN GOTO 350
321 IF SX=R THEN GOTO 385
322 POKE P+L(F)+(MU*SX),S(F)
325 POKE P+L(F)+(MU*SX),0
328 LET SX=SX+1
330 GOTO 300
331 LET L(F)=L(F)+(MU*SX)
333 POKE P+L(F),21
335 GOSUB 2000
336 LET S(F)=0
340 LET Q(F)=10
347 GOTO 217
350 LET T=0
352 IF X>165 AND X<170 THEN LET
T=T+(X-165)
355 IF X>187 THEN LET T=T+(X-18
3)
356 LET L(F)=L(F)+(MU*SX)
360 POKE P+L(F),S(F)
361 IF S(T)>165 AND S(T)<170 TH
EN LET SSF=SSF-1
362 IF SSF=0 THEN GOTO 1000
363 IF S(T)>187 AND S(T)<192 TH
EN LET EEF=EEF-1
364 IF EEF=0 THEN GOTO 1050
365 LET S(T)=0
370 LET Q(F)=Q(F)+INT (RND*7)+1
375 IF Q(F)>9 THEN GOTO 332
380 GOTO 405
385 LET L(F)=L(F)+(MU*SX)
387 GOTO 400
400 POKE P+L(F),S(F)
405 LET F=F+1
410 LET U1=U1+1
420 IF U1>8 THEN GOTO 430
425 GOTO 217
430 LET U1=1
435 GOTO 215
500 POKE P+567,S(F)
510 POKE P+576,C(F)+26
515 POKE P+585,Q(F)+28
520 POKE P+534,U+28
525 RETURN
600 LET K=L(F)
601 LET J=0
602 LET Y=0
603 LET AB=0
605 IF C(F)=0 OR C(F)=4 THEN LE
T J=32
610 IF C(F)=2 OR C(F)=6 THEN LE
T J=34
615 IF C(F)=3 OR C(F)=7 THEN LE
T J=33
620 IF C(F)=1 OR C(F)=5 THEN LE
T J=1
621 LET AB=J
623 LET U=0
625 LET N=1
630 LET V=1
632 LET U1=1

```

```

635 LET U=PEEK (P+K+(J*U1))
645 IF U=0 THEN GOTO 661
648 IF U=21 THEN GOTO 677
650 IF (U=61 OR ABS (S(F)-U)<5)
AND N=1 THEN LET V=5
655 IF (U=61 OR ABS (S(F)-U)<5)
AND N=2 THEN LET V=10
657 IF V=5 OR U=10 THEN GOTO 66
1
660 GOTO 700
661 IF V=5 THEN GOTO 687
663 IF V=10 THEN GOTO 900
665 POKE P+K+(J*U1),27
670 POKE P+K+(J*U1),0
677 LET V=V+1
679 LET U1=U1+1
680 GOTO 635
687 LET U1=1
688 LET V=V+1
690 LET N=2
691 LET J=-AB
696 GOTO 635
700 IF U>165 AND U<170 THEN LET
Y=Y+(U-165)
705 IF U>187 AND U<192 THEN LET
Y=Y+(U-183)
707 LET F=Y
710 IF V=1 OR U=6 THEN LET Q(Y)
=Q(Y)+INT (RND*7)+4
715 IF V=2 OR U=7 THEN LET Q(Y)
=Q(Y)+INT (RND*6)+3
720 IF V=3 OR U=8 THEN LET Q(Y)
=Q(Y)+INT (RND*5)+2
722 IF V=4 OR U=9 THEN LET Q(Y)
=Q(Y)+INT (RND*4)+1
724 IF V=5 OR U=10 THEN LET Q(Y)
=Q(Y)+INT (RND*3)+1
730 IF Q(Y)>9 THEN GOTO 740
732 IF AC=2 THEN LET F=XX
733 IF AC=2 THEN GOTO 227
735 IF AC=1 THEN GOTO 760
740 POKE P+L(Y),21
742 IF U>165 AND U<170 THEN LET
SSF=SSF-1
743 IF SSF=0 THEN GOTO 1000
744 IF U>187 AND U<192 THEN LET
EEF=EEF-1
745 IF EEF=0 THEN GOTO 1050
746 POKE P+L(Y),21
750 LET S(Y)=0
755 GOTO 900
760 LET AC=2
761 GOTO 600
762 LET K=L(Y)
765 IF N=1 THEN GOTO 769
766 LET N=1
767 GOTO 775
769 LET N=2
775 IF N=1 THEN LET V=1
780 IF N=2 THEN LET V=5
782 LET U1=1
783 LET J=-J
785 GOTO 680
790 LET F=F+1
795 GOTO 217
900 LET F=XX
905 LET AC=2
910 GOTO 217
920 INPUT M$
930 IF LEN M$<>1 OR CODE M$<28
OR CODE M$>37 THEN GOTO 920
935 IF CODE M$=36 THEN GOTO 920
940 LET M=VAL M$
950 RETURN
1000 CLS
1005 PRINT " AN ENGLISH WIN"
1010 PRINT
1020 PRINT "ANOTHER GAME?"
1025 INPUT O$
1026 IF LEN O$=0 THEN GOTO 1025
1027 IF O$(1)="Y" THEN GOTO 1032
1030 IF O$(1)="N" THEN NEW
1031 GOTO 1025
1032 CLS
1035 RUN 5
1050 CLS
1055 PRINT " A SPANISH WIN"
1060 GOTO 1010
2000 IF S(F)>165 AND S(F)<170 TH
EN LET SSF=SSF-1
2010 IF SSF=0 THEN GOTO 1000
2015 IF S(F)>187 AND S(F)<192 TH
EN LET EEF=EEF-1
2020 IF EEF=0 THEN GOTO 1050
2030 RETURN
2050 SAVE "TRAFALGA"
2055 GOTO 1

```

**DON'T MISS THIS  
INCREDIBLE OFFER!  
50 GAMES**



**YES, 50 GAMES!** on cassette for all the following:

- |                   |                   |                 |
|-------------------|-------------------|-----------------|
| GALACTIC ATTACK   | WAZE EATER        | SUBMARINES      |
| SPACE MISSION     | GREYTER           | ROCKET LAUNCH   |
| LUNAR LADDER      | WOTOMBY           | PLANETS         |
| PLASMA BOLT       | FORCE FIELD       | BLACK HOLE      |
| ESMETER           | SUM               | DYNAMITE        |
| RADAR LANDING     | TUNNEL ESCAPE     | GO YOUR OWN WAY |
| ATTACKER          | BARREL JUMP       | DERBY DASH      |
| GALACTIC BOGFIGHT | CANNONBALL BATTLE | SPACE SEARCH    |
| ZION ATTACK       | OVERTAKE          | UNIVERSE        |
| TV ADVICE ACTION  | BITTING TARGET    | SAITS           |
| Q&A               | SMASH THE WINDOWS | TANKER          |
| BOGGLES           | SPACE SHIP        | PARACHUTE       |
| PINTOON           | JET F LIGHT       | JETMOBILE       |
| SKI JUMP          | PHASER            | HIGH RISE       |
| HANGMAN           | INTRUDER          | THE FORCE       |
| OLD BONES         | REWARD            | EXCHANGE        |
| THIN ICE          | GHOSTS            |                 |

- sinclair SPECTRUM**  
**apple** (ON DISC & CASSETTE)  
**ACORN-ATOM**  
**BBQ**  
**DRAGON**  
**ATARI VIC 20**  
**SHARP ORIC-1**  
**NEW BRAIN ZX81 LYNX**

POSTAGE FREE TO U.K. ORDER DIRECT TO:  
 U.S. P.O. Box 96  
 HARROGATE NORTH YORKSHIRE HG3 2UZ

PLEASE SEND ME \_\_\_\_\_  
 CHEQUE ENCLOSED, VALUE \_\_\_\_\_  
 NAME \_\_\_\_\_  
 ADDRESS \_\_\_\_\_  
 POSTCODE \_\_\_\_\_ G/223

**cut & post now**

**SOUND with SINCLAIR**

**MAKE AMAZING SOUND EFFECTS WITH YOUR ZX 81, TIMEX Sinclair 1000 or SPECTRUM**



**THE ZON X 81**  
**£25.95**  
 incl p&p & VAT

- The ZON SOUND UNIT is completely self-contained and especially designed for use with the ZX 81, TIMEX Sinclair 1000 and Spectrum Computers. It just plugs in — no dismantling or soldering.
  - No power pack, batteries, leads or other extras.
  - Manual Volume Control on panel — ample volume from built-in loudspeaker.
  - Standard Sinclair — 16K Rampack or printer can be plugged into ZONX Sound Unit without affecting normal computer operation.
  - Huge range of possible sounds for Games, Music, Helicopters, Sci-Fi, Space Invaders, Explosions, Gun-shots, Drums, Planes, Lasers, Organs, Bells, Tunes, Chords, etc. or whatever you devise!
  - 8 full octaves. Uses 3-Channel sound chip giving programme control of pitch, volume of tones and noise, all with envelope control.
  - Easily added to existing games or programs using a few simple "BASIC" lines or machine code.
  - No memory addresses used — I/O mapped.
- FULL instructions with many examples of how to obtain effects and the programmes, supplied. Fully guaranteed. British Made.**
- \*Except with Spectrum, you need the Spectrum Extension Board Order No. SE1 - PRICE £6.80 inc. VAT.*
- Payment may be made by Cheque, P.O. Giro No. 388 7006, Postal Order or Credit Card.
- Export orders:- Bank Cheque, International Money Order, U.S. or £ Sterling.

**BI-PAK** Dept CG4, P.O. Box 6, 63A, High Street, Ware, Herts.

Access & VISA accepted Ring 0920 3182 for immediate despatch.



**ALLRIAN DATA SERVICES**  
 1000a, Uxbridge Rd, Hayes, Middx.  
 UB4 0RL

**Beta Fighter** cass 15.50 disk 18.95  
 16k - thwart the aliens - fought against a 3D Martian landscape - for 1 or 2 players.

**Pilot** cass 15.50 disk 18.95  
 16k - real time - you are in the cockpit of a light aircraft - now land it!

**Strip Poker** disc 27.50  
 40k - ultra hi-res graphics - too realistic to illustrate! What mother never told you about video games!!!!

**Remember!** we MAKE 'em - never out of STOCK - prompt despatch.



ALL PRICES INCL. VAT - P&P FREE.

Manufactured in the UK for  
**Artwax**

**GAMER**



**ATARI 400 & 800**

400 (exc. basic) £149.50  
 800 (inc. basic) £375.00

**PACKAGE DEALS**

- 400 (16k) + basic + recorder + joystick + 5 blank cassettes + demos/games **£239**
- 400 (48k) + all above items **£324**
- 800 (48k) + all above items **£485**
- 800 (48k) + basic + disk drive + joystick + 3 blank disks + demo disk **£720**

Dragon 32	£199	Spectrum (48k)	£175
Epson HX20	£462	Oric (48k)	£169
Vic 20	£129	Sord M5	£189
Commodore 64	£339	Sharp MZ80A	£449
ZX 81	£49.95	Sharp MZ80B	£899.00
ACE	£89.95		

ALL PRICES INCLUDE VAT

**24 GLOUCESTER ROAD  
 BRIGHTON 698424**

You are a pilot on a life or death mission. Can you bomb a clear pathway through the city of skyscrapers wide enough for your aircraft to land?

The silhouette of a skyscraper city is drawn on the screen; and at the top is a plane, which traverses from left to right, its altitude reducing on each traverse. If it hits a skyscraper the game ends.

Bombs may be dropped by pressing the space bar.

If a bomb hits a building it reduces it in height by one story.

The plane may be raised one line on the screen five times only, by pressing the 'UP' arrow.

A variable difficulty level is provided in the speed of the plane, which may be 1-5. At speed 1 (fast) each hit scores five points, and at speed 5 (slow) each hit scores one point, etc.

A high-score feature is available, and retains the current highest score whilst the machine is switched on and the game loaded, provided it is not re-RUN.

#### VARIABLES

I,J,K: Loop counters  
 PLS: Plane graphic  
 NPS: Blank, same size as plane  
 BOS: Bomb graphic  
 PO: Current 'PRINT@' position of plane  
 BD: 0 if no bomb in flight, else = 1  
 SP: The start position (PRINT@) of a bomb  
 RA: The current no of raises left  
 A: The points value of each bomb hit  
 GS: A delay factor affecting plane speed  
 CT: The counter which uses the delay factor  
 HS: The current high-score  
 SC: The player's current score

#### Notes on Peeks and Pokes

To help convert to other machines, it is necessary to explain the PEEKS and POKES. First, be aware that the Dragon screen is 32 characters wide and 16 high. Print positions start at 0 (top left) and end at 511 (bottom right).

Video memory starts at decimal RAM address of 1024. Thus RAM address 1025 = PRINT@ position 1. All PEEKS and POKES in the listing are directed at the screen.

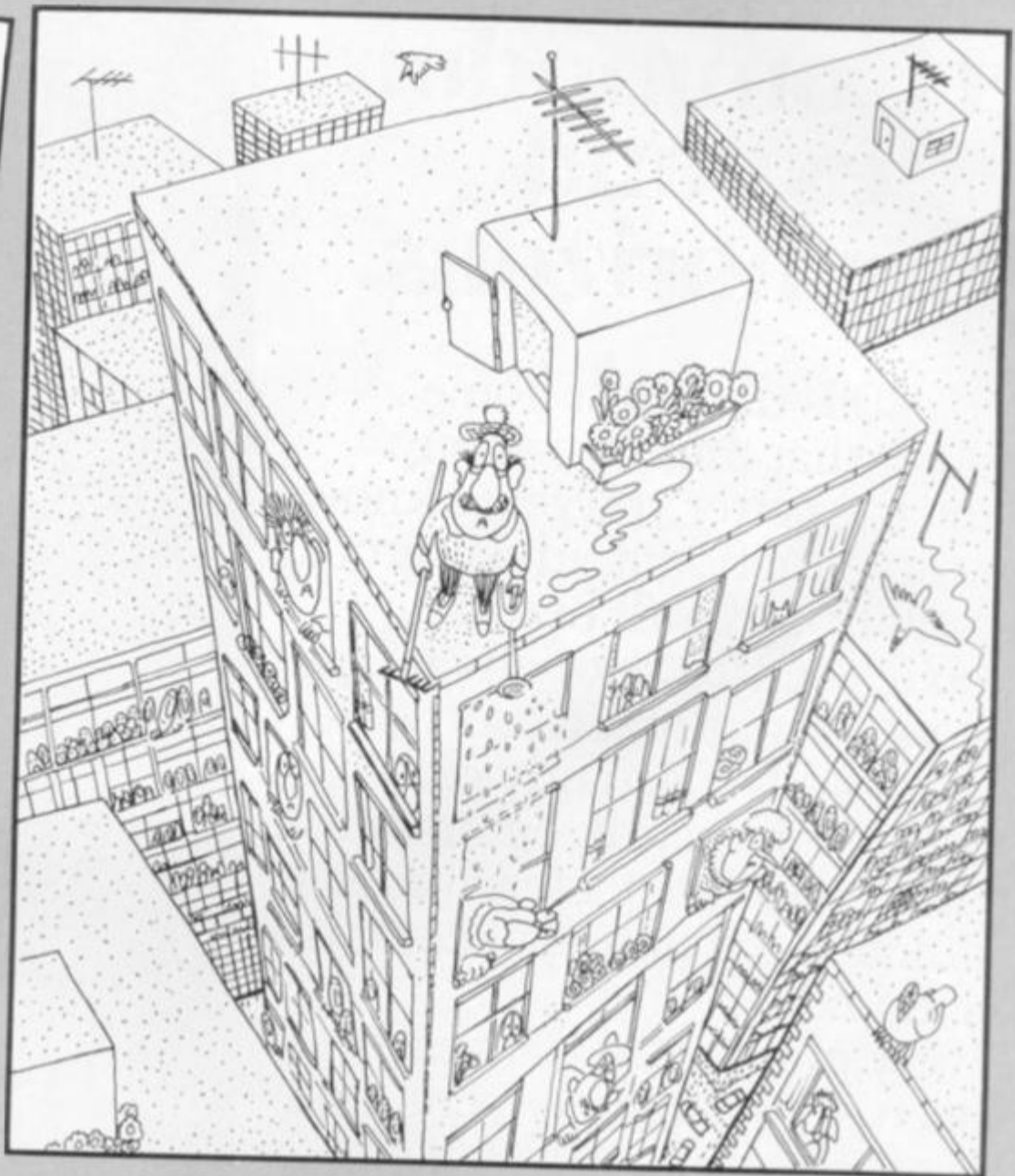

# SKYSCRAPER

BY KEITH CAMPBELL

RUNS ON A DRAGON 32 IN 32K

```

1 CLS:PRINT@35,"SKYSCRAPER !":FO
RI=0T01000:NEXT
2 CLS:PRINT"YOU ARE THE PILOT OF
A BOMBER. YOUR PLANE IS CRIPPL
ED AND YOU CAN ONLY CIRCLE THE
CITY OVER WHICH YOU FIND YOURS
ELF"
3 PRINT"YOU ARE RUNNING OUT OF F
UEL, ANDTHE ONLY WAY YOU CAN LAN
D IS TO FLATTEN THE CITY BY BOMB
ING IT. YOU CAN RAISE YOUR PLANE
5 TIMESONLY BY PRESSING THE UP
ARROW"
4 PRINT"YOU CAN DROP A BOMB BY P
RESSING THE SPACE BAR.":PRINT:PR
INT"PRESS ENTER TO COMMENCE":IN
PUTA$
5 CLS:PRINT"ENTER YOUR PLANE SPE
ED.":PRINT:PRINT"1 IS FAST":PRIN
T"5 IS SLOW":INPUTS$
6 S=INT(ABS(VAL(S$))):IFS<10RS>5
THENELSEGS=S:A=6-5
10 FORI=1024T01535:POKEI,128:NEX

```

```

T
20 FORI=1504T01535:J=I
30 FORK=0TORND(12):POKEJ-K*32,14
3:NEXT:NEXT
40 PL$=CHR$(142)+CHR$(139)+CHR$(
130)
50 NP$=STRING$(3,CHR$(128)):PO=3
2:BO$=CHR$(129):RA=5:SC=0
55 PRINT@0,"SCORE!":PRINT@17,"H
I-SCORE!":HS:
60 PRINT@PO,PL$:PRINT@PO-1,CHR$
(128):
65 CT=0:IFPO>473THEN2000
70 Z$=INKEY$:IFBD=1ANDZ$=" "THEN
100ELSEIFZ$="C"ANDRA>0THENIFFPO>6
4THENPRINT@PO,NP$:PO=PO-32:RA=R
A-1
75 CT=CT+1:IFCT < GS THEN70ELSEP
O=PO+1
80 IFPEEK(PO+1026)=143THENCLS:PR
INT@150,"SPLAT!":PRINT:PRINT"YOU
CRASHED INTO A SKYSCRAPER!":PRI
NT"YOUR SCORE WAS:-":SC:GOSUB250

```

```

0:PRINT"DO YOU WANT ANOTHER GO":
INPUTU$:IFLEFT$(U$,1)="Y"THENSE
LSEEND
90 IFBD=1THENGOSUB1000:GOTO60ELS
EGOTO60
100 IFBD=1THEN110ELSEBD=1:SP=PO:
GOSUB1000:GOTO60
110 GOSUB1000:GOTO60
1000 IFSP+32>479THEN80=0:POKESP+
1024,128:RETURNELSEIFPEEK(SP+32+
1024)=143THENPOKESP+32+1024,128:
SOUND50,2:BD=0:SC=SC+A:PRINT@6,S
C:PRINT@SP,CHR$(128):RETURNELS
EPRINT@SP+32,BO$:PRINT@SP,CHR$(
128):SP=SP+32:RETURN
2000 CLS:PRINT"FANTASTIC!":PRINT
"YOU HAVE RAZED THE CITY TO THE
GROUND!":PRINT:PRINT"YOUR SCOR
E WAS!":SC:GOSUB2500
2010 INPUT"ANOTHER GAME":A$:IFLE
FT$(A$,1)="Y"THENSELSEEND
2500 IF HS < SC THENLETHS=SC
2510 RETURN

```

# Let Commodore expand your horizons.

VIC 20 is the finest home computer that money can buy.

And the better you get to know it, the more confident, adventurous and ambitious you'll become.

You'll want to take advantage of the vast range of VIC software: a superb and constantly-growing selection of programs, embracing business systems, entertainment, education and many applications in the home.

Every program in the series has been designed by experts, and chosen for its quality and value for money.

VIC business software covers a wide range of applications, including spread-sheet analysis, stock control, information handling and word-processing.

A mind-blowing range of games including Scott Adams' world-famous 'Adventure' series.

Advanced space games, including the sophisticated 'Omega Race'.

Learn subjects as diverse as English Language, programming, and biology.

And 'home' software ranges from IQ tests to Robert Carrier menus.

In addition, there is a range of VIC software, like programmers' aids and graphics packages—

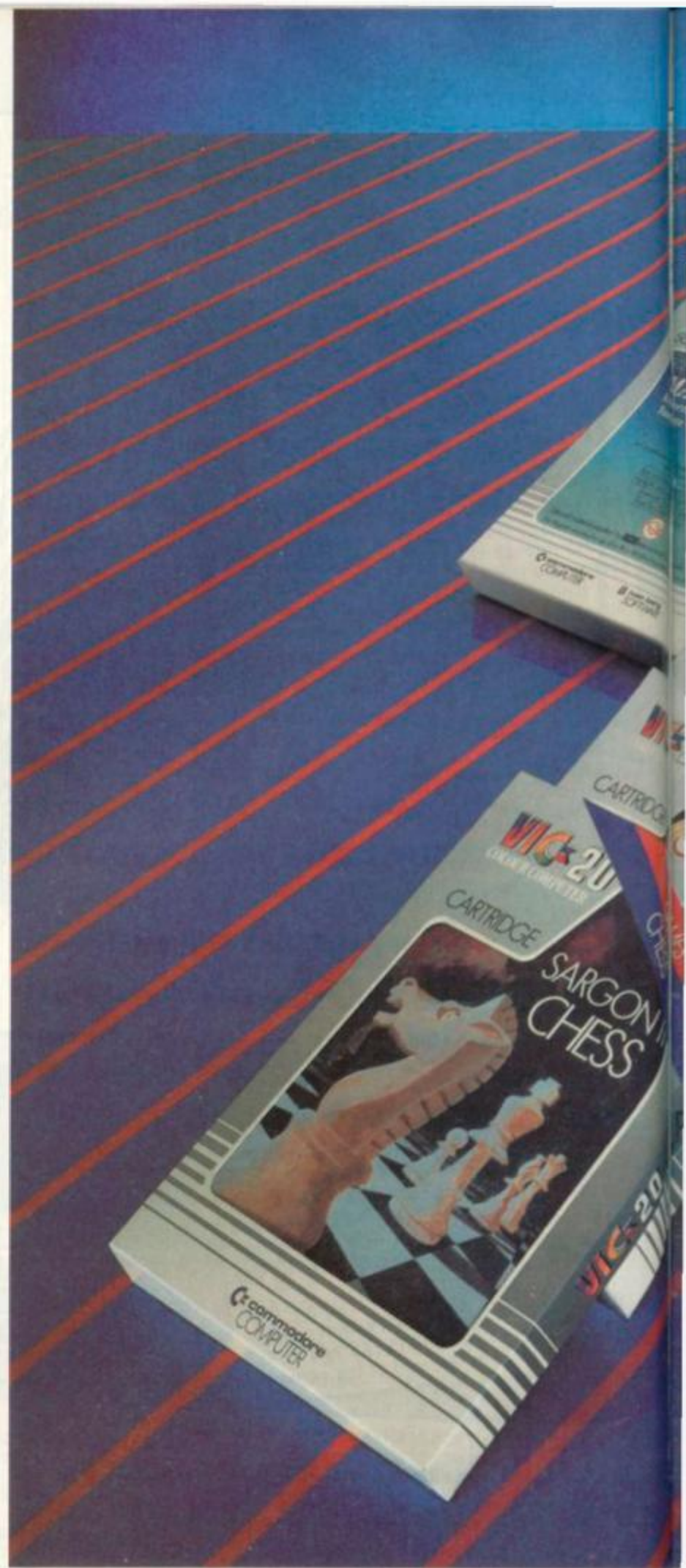

to add to your understanding and enjoyment of computers and computing.

There's even a special 'VicSoft' Club for VIC 20 enthusiasts, with many advantages including special offers to club members.



VIC software will expand your horizons. And your mind.

PRICES RANGE FROM £4.99 to £24.95 INC. VAT.

**commodore**  
**VIC 20**



For more information, a catalogue of VIC software and details of your local retailers or dealers please phone or complete the coupon and send to:  
The Commodore Information Centre,  
675 Ajax Avenue, Slough, Berkshire SL1 4BG.  
Telephone: Slough (0753) 79292.

Name \_\_\_\_\_  
(MR./MRS./MISS)  
Address \_\_\_\_\_  
\_\_\_\_\_  
Postcode \_\_\_\_\_

# OUT OF THIS WORLD SOFTWARE...



PLEASE SEND ME ..... @ £ .....

PLEASE SEND ME ..... @ £ .....

PLEASE SEND ME ..... @ £ .....

PLEASE ADD ON 50p for P&P  
I enclose cheque/P.O. payable to

DK Tronics total ..... or debit my

Access/Barclaycard

NAME ..... ADDRESS .....

SIGNATURE .....

**CREDIT CARD SALES LINE**  
**(0493) 602453 (24 hrs)**

**Quoting your Access or Barclaycard number  
DK Tronics software is also available from all  
good software outlets.**

**3D TANX**—Pit your wits against the enemy Tanx. This is a full feature game with fantastic 3D ballistics. **ONLY £4.95**

**3D SPAWN OF EVIL**—Eliminate the spawn before it matures to full attack potential. The most spectacular 3D space game ever written for this 16K Spectrum. **ONLY £4.95**

**CENTIPEDE**—Shoot down the ever menacing Centipede before it shoots you. One of the most addictive games for the Spectrum **ONLY £4.95**

For more information send S.A.E. for our full colour brochure.



**DICTATOR**—Can you survive as Dictator? A complex and entertaining simulation adventure featuring easy operation and excellent use of graphics **ONLY £4.95**

**METEORIDS**—The best Spectrum version of this popular arcade game **ONLY £4.95**

**SOUND FX**—Even the beginner can use this fantastic program to create and infinitely variable amount of machine code sounds **ONLY £4.95**

**DISASSEMBLER**—A fast machine code disassembler for use on the 48K and 16K Spectrum giving full colour output to the screen **ONLY £4.95**

**ZXED (Toolkit)**—A powerful editor for use on the 16K and 48K Spectrum. It creates several useful and time saving features **ONLY £6.95**

...from

**ORBITRONICS**

23 Sussex Road, Gorleston, Gt. Yarmouth, Norfolk.



Space, as you well know, is a dangerous place. And we at *Computer and Video Games* are here to bring you all the dangers we can find! This is a subtle new twist to an old favourite.

You are the pilot of a space craft on route to a refuelling station. Blocking your way is a field of stationary aster-

oids. You must dock with the refuelling station — otherwise you will not be able to continue your journey across the universe. Can you navigate the maze of rocks and reach safety? Once you have traversed a Stasteroid field and reached the refuelling zone another is set up by the computer.

There are some flashing sequences in the program that some people may find disturbing. To remove these sequences simply omit the following lines or statements. Line 2520: omit LET l=USR scr. Line 3020: omit both LET l=USR scr. Delete lines 3550 to 3570, 4020, 4320, 4110 to 4140, 4220 to 4250.

# STAR

BY M. J. LEVER

```

100 REM ***** ROUTINE *****
110 CLEAR 64999: REM For m/c
120 GO SUB 9000: REM Instr
130 GO SUB 8000: REM Skill
140 GO SUB 7000: REM Vars
150 GO SUB 6000: REM Screen
160 GO SUB 5000: REM Intro
170 GO TO 1000: REM Start

1000 REM ***** SCREEN *****
1010 FOR a=1 TO 28
1020 PRINT AT od,a-1;" ": LET
c$=SCREEN$(d,a+1)+SCREEN$(d,a+
2): IF c$="" THEN GO TO 3000
1030 PRINT AT d,a,b$(r+1): BEEP
.001,d+20: BEEP .001,40: LET od=
d: LET i$=INKEY$: LET d=d+(i$="Z
" AND d<21)-(i$="1" AND d>1)
1040 LET fuel=fuel-1: LET sc=sc+
1: LET r=NOT r: PRINT AT 0,10-LE
N STR$ sc;sc;AT 0,16;"00": TO 3-
LEN STR$ fuel): fuel: IF NOT fuel
THEN GO TO 2500
1050 NEXT a

2000 REM ***** FUEL *****
2010 PRINT AT od,a-1;" ": FOR x=
1 TO 5: BEEP .05,0: BEEP .05,1:
NEXT x: IF od<>p THEN GO TO 2100
2020 FOR x=1 TO 28+INT (RAND*(lev
+1))
2030 PRINT AT p,29: INK 2;"X";
INK 6;"0": BEEP .02,x+5: LET fue
l=fuel+1
2040 PRINT AT p,29;b$(1,4 TO );
INK 2;"0": BEEP .02,30-x: PRINT
AT 0,19-LEN STR$ fuel;fuel: NEXT
x
2100 LET sect=sect+1: IF sect=11
THEN GO SUB 3500
2110 GO SUB 7200: GO SUB 6020: G
O TO 160

2500 REM ***** FUEL *****

```

```

2510 PRINT AT 0,16: INK 6: FLASH
1;"000"
2520 INK 6: PAPER 8: FOR x=od+1
TO 21: POKE attr,64+INT (RAND*8)+
8: LET l=USR scr: PRINT AT x-1,8
:" " AT x,a+1;"X": BEEP .01,5
0-x: BEEP .01,51-x: NEXT x: POKE
attr,72: LET l=USR scr
2530 POKE 23693,71: FOR x=1 TO 5
: PRINT AT 21,a+1: INK 5;"X": B
EEP .01,20: PRINT AT 21,a+1;" "
: BEEP .02,20: NEXT x
2540 POKE attr,71: LET l=USR scr
: FOR x=1 TO 10: PRINT AT 21,a+1
:"X": BEEP .01,x+5: NEXT x
2550 PRINT AT 21,a+1;" "
2560 POKE 23693,71: FOR x=1 TO 2
00: NEXT x
2570 GO TO 4000

```

```

3000 REM ***** LIVES *****
3010 FOR x=1 TO 20: PRINT AT d,a
+1: INK 6;"X": BEEP .01,25: PRI
NT AT d,a+1: INK 1;"X": BEEP .0
1,26: NEXT x
3020 FOR x=20 TO 10 STEP -1: POK
E attr,80: LET l=USR scr: PRINT
AT d,a+1:"X": BEEP .02,x: POKE
attr,104: LET l=USR scr: PRINT A
T d,a+1;" " NEXT x
3030 POKE attr,71: LET l=USR scr
: LET lives=lives-1
3040 GO SUB 6100: IF NOT lives T
HEN GO TO 4000
3050 LET fuel=150: GO TO 2110
3500 REM ***** SECTOR *****

```

```

3510 PRINT AT 8,0;" ENTERI
NG NEW SECTOR" "PREPARE FOR JU
MP TO LIGHT SPEED"
3520 FOR x=0 TO 60 STEP 5: BEEP
.01,x: NEXT x
3530 IF sk<.9 THEN LET sk=sk+.1
3540 GO SUB 7010
3550 FOR x=0 TO 7: POKE attr,x+8
+64+7-x: LET l=USR scr: BEEP .01
,x+20: POKE attr,8*(7-x)+64+x: L
ET l=USR scr: BEEP .01,20-x: NEX

```



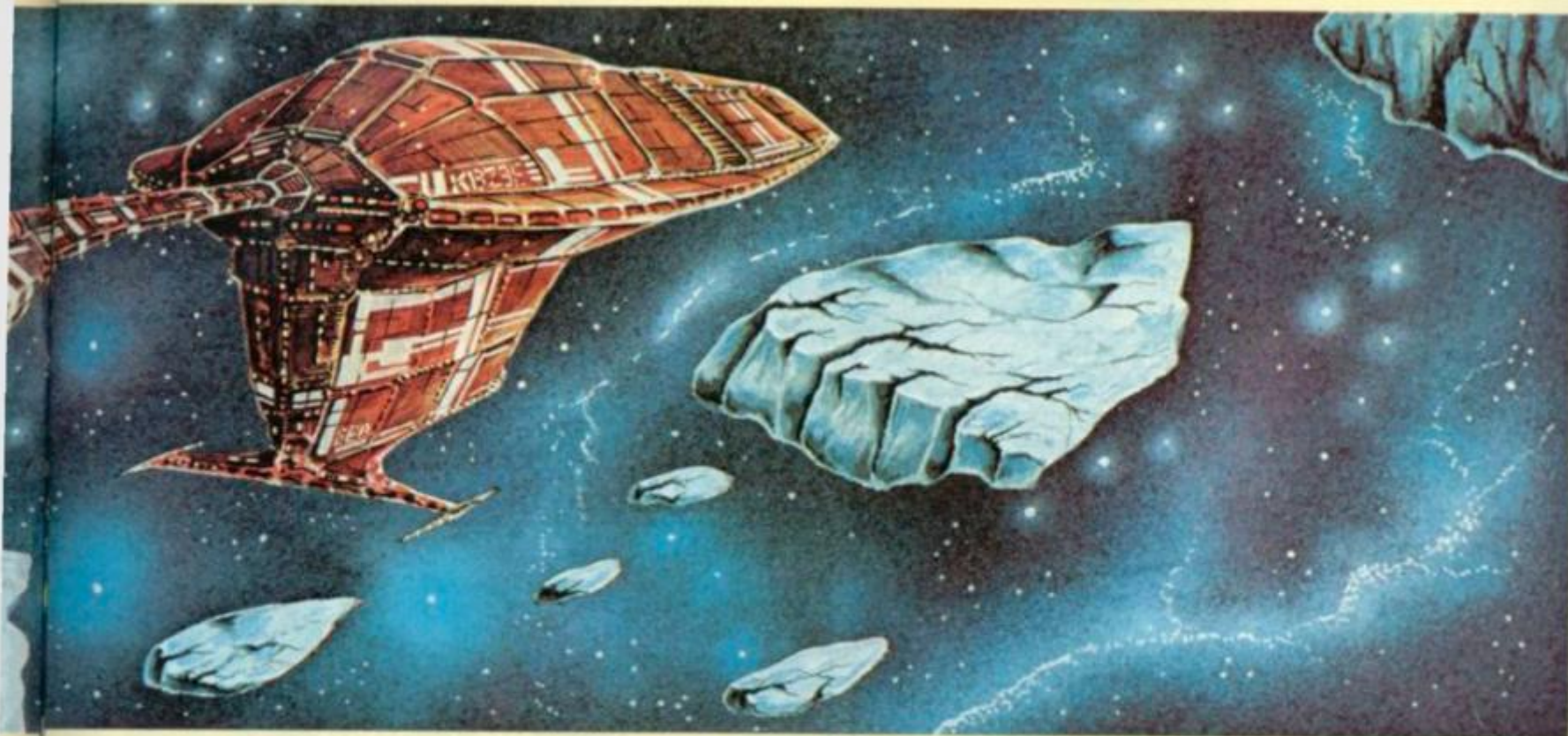

# ASTEROIDS

RUNS ON A SPECTRUM IN 48K

```

T x
3560 FOR x=1 TO 10: POKE attr,92
: LET l=USR scr: PAUSE 2: POKE a
ttr,73: LET l=USR scr: BEEP .02,
10: NEXT x
3570 PRINT PAPER 8; INK 8; AT 9,0
,,,,,: POKE attr,71: LET l=USR
scr
3580 LET fuel=fuel+50: LET sect=
1: RETURN
4000 REM SETS UP
4010 PRINT AT 7,0,"
AME OVER",,,, PAUSE 50
4020 FOR x=0 TO 255 STEP 3: OUT
254,x: POKE attr,x: BEEP .005,x/
4: LET l=USR scr: NEXT x
4030 POKE attr,71: LET l=USR scr
4040 FOR x=1 TO 100: NEXT x
4050 FOR x=1 TO 24: LET l=USR 35
62: PAUSE 1: NEXT x
4060 CLS
4070 IF sc<=s(lev) THEN FOR x=1
TO 100: NEXT x: GO TO 4200
4080 PRINT "
CONGRATULATIONS
!! YOU HAVE"
QUALIFIED FOR T
HE STASTEROIDS"
HALL OF FA
ME AT LEVEL 0":lev
4090 FOR x=1 TO 5: FOR y=10 TO 6
0 STEP 5: BEEP .01,y: NEXT y: NE
XT x: PRINT "
PLEASE ENTER YO
UR NAME BELOW"
(MAXIMUM OF
12 CHARACTERS)"
4100 INPUT LINE z$: IF z$="" OR
LEN z$>12 THEN BEEP .2,-20: BEEP
.3,-30: GO TO 4100
4110 LET s$(lev)=z$: LET s(lev)=
sc
4200 CLS
4210 PRINT INK 6;"
H A L L
OF F A M E" INK 5;"
4220 PRINT INK 6;" LEVEL
NAME SCORE" INK 5;"
4230 PRINT
4240 FOR x=1 TO 9: PRINT TAB 3;x

```

```

;TAB 10;s$(x);TAB 27;s(x): NEXT
x
4250 PRINT INK 5;"
4260 PRINT "
INK 5;" PRESS ENT
ER FOR ANOTHER GAME"
4270 LET i$=INKEY$: IF i$="" THE
N BEEP .1,-PEEK 23672/5: GO TO 4
270
4275 IF i$<>CHR$ 13 THEN GO TO 4
290
4280 FOR x=10 TO 20: BEEP .1,x:
NEXT x: GO SUB 4800
4285 IF i$="n" THEN GO TO 130
4286 LET fuel=150: LET sc=0: LET
sect=1: LET lives=3: GO SUB 720
0: GO TO 150
4290 CLS
4310 PRINT AT 8,0;"
= END THE
4320 POKE 65003,0: POKE 65006,24
: FOR x=0 TO 7: FOR y=0 TO 7: PO
KE attr,x+8+y: LET l=USR scr: BO
RDER y: BEEP .05,y+x: NEXT y: NE
XT x
4330 BORDER 0: POKE attr,71: LET
l=USR scr: PAUSE 50: FOR x=1 TO
11: LET l=USR 3582: PAUSE 1: NE
XT x
4340 INK 0: CLS
4345 FOR x=29 TO 32: CIRCLE 130,
109,x: NEXT x: CIRCLE 125,104,30
4350 PRINT AT 6,12;"COMPUTER":AT
8,13;"& VIDEO":AT 10,14;"GAMES"
4360 PLOT 93,101: DRAW 64,0: DRA
W 13,13: DRAW -64,0: DRAW -13,-1
3
4380 FOR x=1 TO 7: POKE attr,x:
LET l=USR scr: PAUSE 4: NEXT x:
GO TO 4380
4800 PRINT "WOULD YOU LIKE THE
SAME SECTOR?"
4810 LET i$=INKEY$: IF i$<>"y" A
ND i$<>"n" THEN GO TO 4810
4820 RETURN
5000 REM SETS UP

```



# Calisto Computers Ltd.

119 JOHN BRIGHT STREET  
BIRMINGHAM

021-632 6458



<b>ATARI 400</b> with Basic language £199.98 without Basic language £159.99	<b>ATARI 800</b> with Basic language 48K £399.99	<b>ATARI 410</b> Cassette Recorder £49.99	<b>ATARI 810</b> Disc Drive with DOS II £299.95
<b>ATARI 400 48K</b> INC BASIC £299.99	<b>ATARI Programmers</b> Kit £39.99	Large range of <b>JOYSTICKS</b> from £7.00	<b>UPGRADES</b> for ATARI 400 32K £75.00 48K £99.95



## PREPPIE

Tee off on this crazy green. Cross the alligator filled river to recover wayward golf balls. In this game danger lurks everywhere. With 28 Atari colours and super graphics, this game will delight and thrill the gamer.

Cassette £21.99 Disc £21.99

## ELIMINATOR

Fans of this game — now it's available for the Atari 400 and 800. Pilot your Eliminator Craft over alien terrain and fight the hordes of marauding enemy ships. Superlative graphics and realistic sounds make this arcade style game exciting to the end.

Cassette £17.99 Disc £17.99



## SEA DRAGON

Prepare to dive in your nuclear armed sub. Guide your submarine through a labyrinth of passages and past underwater mountains. Try to avoid webs of explosive mines that rise from the sea bottom. With mine dropping ships above, deadly lasers and stalactites, try to reach your goal — destruction of the nuclear reactor. Will you succeed in this creative game?

Cassette £25.49 Disc £25.49

## STRATOS

This is a kaleidoscope explosion of awesome graphics and other-worldly sounds beyond all arcade style games. Above futuristic Megopolis sweep a wave of alien craft releasing awesome weaponry — the terrifying matter ravagers! With your joystick control of the Armageddon wave can you destroy them in time?

Cassette £25.49 Disc £25.49



## FLOYD OF THE JUNGLE

This is a fun game you can play with the family. Guide Floyd through the perilous jungle to save the lovely Janice. Fully animated with music and sound effects.

Cassette £29.95 Disc £29.95

## CHOPPER RESCUE

Immerse yourself in non-stop excitement in your sleek assault chopper. Features 3 scenarios, multiple skill levels and competition in solo or team configurations of 1-4 players.

Cassette £29.95 Disc £29.95



## HELLCAT ACE

Air to Air Combat in the Pacific. A full range of high-performance aerobatics inc. loops, stalls, rolls, Immelman turns and spins. Full 3 dimensional airspace. Fifteen well documented scenarios.

Cassette £29.95 Disc £29.95

## MINER 20/49ER

This is the story of Bounty Bob and his intrepid attempt to capture Yukon Yohan in the abandoned uranium mine. Duck and dodge your way to a high score, but beware of the deadly mutant organisms.

ROM £29.99



## ZAXXON

This sensational arcade game of 1982 is now available for use on your home computer system. Fly through a three dimensional like playfield to attack the fortress and its deadly armoured Robot. Survive this battle and earn the ultimate challenge!

Cassette £29.99 Disc £29.99

## ASTRO CHASE

Here is the ultimate challenge. Defend the Earth from an awesome attack by aliens. There is no escape from their force field set around our galaxy! They launch their attack vessels and the chase begins — avoid deadly lasers, destroy space mines — save the Earth from inevitable doom.

Cassette £26.50 Disc £26.50

To: CALISTO COMPUTERS LTD, 119 JOHN BRIGHT STREET, BIRMINGHAM.  
PLEASE ACCEPT MY ORDER FOR THE FOLLOWING PROGRAMS:-

- .....
- .....
- .....
- .....
- .....

Cheque No. .... for £ ..... enclosed.

Please debit my credit card ACCESS/VISA No. ....

Phone orders welcome on 021-632 6458. Signed .....

## Calisto Computers Ltd.

Despatch to: .....

Name: .....

Address: .....

SPECIALISTS IN MICROCOMPUTERS AND SOFTWARE  
119 JOHN BRIGHT STREET, BIRMINGHAM B1 1BE  
Telephone: 021-632 6458

```
5010 FOR x=0 TO 10: BEEP .05,x:
BEEP .05,x+1: BEEP .05,10-x: NEX
T x
5020 BEEP .2,0
5030 FOR x=1 TO 100: NEXT x
5900 RETURN
```

```
6000 REM SET UP VARIABLES
```

```
6010 POKE 23693,71: BORDER 0: CL
S
6020 PRINT AT 0,0:"SCORE:0000 FU
EL:000 SUBSECTOR:00": AT 0,10-LEN
STR$ sc:sc: AT 0,19-LEN STR$ fue
l:fuel: AT 0,32-LEN STR$ sect:sec
t: OVER 1: PRINT INK 6: AT 0,0:"
": AT 0,11:"": AT 0,20:"
": OVER 3
6030 PRINT AT 1,0: INK 7: FOR x
=1 TO 21: PRINT a$(sect,x): NEXT
x
6040 LET p=INT (RAND*19)+2: PRINT
AT p-1,29:"": AT p,29: INK IN
T (RAND*3)+3:" @": AT p+1,29:"
": AT 11,0:b$(1,4 TO )
6100 INPUT "": PRINT #0:" SHIPS:
": FOR x=1 TO lives: PRINT #0:
INK INT (RAND*3)+4:"@": NEXT
x
6900 RETURN
```

```
7000 REM SET UP VARIABLES
```

```
7005 LET sc=0: LET lives=3: LET
fuel=150: LET sect=1
7010 DIM a$(10,21,32): LET na=sk
+90: LET inc=1
7020 FOR x=1 TO 10
7030 FOR y=1 TO na
7040 LET d=INT (RAND*21)+1: LET a
=INT (RAND*32)+1: IF a$(x,d,a) <>
" THEN GO TO 7040
7050 LET a$(x,d,a)="0"
7060 NEXT y
7070 IF x=6 THEN LET inc=-inc
7075 LET na=na+inc+INT (RAND*(sk+
.6)+19+5)
7080 IF na<=0 THEN LET na=10
7090 FOR z=10 TO 12: LET a$(x,z,
TO 5)="": NEXT z
7100 NEXT x
7200 LET d=11: LET a=0: LET od=d
: LET oa=a
7210 LET r=0
7900 RETURN
```

```
8000 REM LEVEL SELECTION
```

```
8010 POKE 23693,58: BORDER 7: CL
S
8020 PRINT AT 7,0:" SELEC
T A LEVEL "
8030 PRINT " (1 - EASIEST, 9
- HARDEST)"
8040 POKE attr,56+INT (RAND*5): L
ET l=USR scr: LET i$=INKEY$: IF
i$<"1" OR i$>"9" THEN BEEP .01,R
ND*20: GO TO 8040
8050 LET sk=VAL i$/10
8200 POKE 23693,23: BORDER 0: CL
S
8220 PRINT AT 5,0: PAPER 0 " F
'LEASE WAIT "
8230 LET lev=VAL i$
8900 RETURN
```

```
9000 REM THE MAIN GAME - LET CHIT 3
```

```
9010 POKE 23693,71: BORDER 0: CL
S
9020 POKE 23658,0: RANDOMIZE : R
ESTORE
9030 FOR x=USR "a" TO USR "g"+7
9040 READ a: POKE x,a
9050 NEXT x
9060 FOR x=1 TO 10
9070 READ a: POKE x+64999,a
9080 NEXT x
9090 LET a$=""
40105STASTE
9100 LET scr=65000: LET attr=scr
+1
9110 FOR x=7 TO 0 STEP -1
```

```
9120 POKE attr,x*8+x+64
9130 LET l=USR scr: BORDER x: B
EEP .3,-x-20
9140 NEXT x
9150 FOR x=1 TO 50: PLOT RND*255
,0: IF x=38 THEN PRINT AT 21,0;a
$( TO 32)
9160 IF x=39 THEN PRINT AT 21,0:
a$(33 TO 64)
9170 IF x=40 THEN PRINT AT 21,0:
a$(65 TO )
9180 LET l=USR 3582: NEXT x
9220 LET z=5: LET n=-20: LET a=.
1: FOR p=1 TO 7: FOR x=1 TO z
9230 POKE attr,p*8+64: LET l=US
R scr: BEEP a,n
9240 POKE attr,71: LET l=USR sc
r: BEEP a,n-5
9250 LET n=n+.5: NEXT x: LET z=z
+3: LET a=a-.01: NEXT p
9260 PRINT AT 12,0:" Copyright
1983 M. J. Levers": FOR n=40 TO
0 STEP -1: BEEP .01,n: NEXT n
9270 PAUSE 100: INK 7: PAPER 0:
POKE 23692,-1: PRINT AT 21,0:
9280 PRINT PAPER 2:" STASTEROIDS
© 1983 M.J. LEVERS "
9290 PRINT " The idea of this g
ame is to pilot a space craft
through a sector of galaxy. T
his may soundsimple but each sec
tor is divi- ded into ten sub-se
ctors. Each of these sub-secto
rs are filled with STASTEROIDS (S
Tationary ASTEROIDS). At the
end of each sub-sector is a ref
uelling stat- ion which you must
try to dock with to replenish y
our fuel. You"
9300 PRINT "start with 150 units
of fuel. Ifit runs out or you c
rash three ships the game ends.
Your score is the distance you
manage to travel."
9305 PRINT " If you reach the en
d of a sector another is ge
nerated."
9310 PRINT "KEYS: 1 - UP, Z -
down"
9320 PRINT #0: PAPER 1:" PLEASE
PRESS ENTER TO CONTINUE "
9330 DIM s$(9,12): DIM s(9): FOR
x=1 TO 9: LET s$(x)="ZX SPECTRU
M": NEXT x
9340 POKE 65003,32: POKE 65006,2
1
9350 DIM b$(2,7): LET b$(1)=CHR$
16+CHR$ 3+"<" +CHR$ 16+CHR$ 6+">"
+CHR$ 16+CHR$ 4+"<"
+b$(1,4 TO )
9360 IF INKEY$<>CHR$ 13 THEN GO
TO 9360
9400 RETURN
```

```
9500 REM DATA FOR THE GAME
```

```
9510 DATA 135,223,50,254,50,223,
135,0
9520 DATA 192,112,204,255,204,11
2,192,0
9530 DATA 68,16,130,40,126,16,12
6,36
9540 DATA 29,21,119,215,119,21,2
9,0
9550 DATA 36,90,129,130,65,129,1
06,20
9560 DATA 0,6,24,98,24,6,0,a
9570 DATA 0,a,6,24,6,0,a,a
```

```
9600 REM DATA FOR THE GAME
```

```
9610 DATA 52,0,17,0,68,6,24,197,
6,32,18,19,16,252,193,16,246,201
```

```
9900 REM The following user
graphics are used:-
A = X B = P C = S D = @
E = O F = < G = *
```

```
9998 REM CAUTION
9999 REM SOME PEOPLE MAY FIND
THIS STROBE EFFECT IN
THE INTRODUCTION
DISRUPTING
```

```

1 REM DRAGON RUN.....BY PETER AND MARK WRIGHT.....JUNE 1982
3 GOSUB 2000
5 DIM N$(50),S$(50),A$(1),Z$(1):POKE 752,1
7 GRAPHICS 0:SETCOLOR 2,14,4:SETCOLOR 4,1,2:N$="SIR "
10 ? "THE SPORT OF DRAGON RUNNING.":? :? "ragon running was an ancient sport"
12 ? " in medievell England.":? :? "The Dragon Runner was taken through"
14 ? "the dragon's forest unarmed. By using":? "skill and cunning alone he had t
o"
16 ? "return to the castle.":? :? "If he succeeded, the Castle Baron":? "would r
eward him with a purse of 100"
18 ? "gold pieces, if he failed.....":? :? "The sport died out as one by one th
e"
20 ? "wandering runners were eaten.":? :? "See how many runs you can make ere "
22 ? "you become a dragon's dinner.":? :? "If you wish to play, please enter":?
"your name and press RETURN"
30 INPUT S$:N$(LEN(N$)+1)=S$
36 GRAPHICS 0:SETCOLOR 2,14,4:SETCOLOR 4,1,2
40 ? :? N$:? :? "YOU ARE NOW A FULLY FLEDGED DRAGON":? "RUNNER IN PERSONA (D.R.I
.P.)"
45 ? :? "YOU ARE CHARGED THAT USING ONLY THE"
50 ? "ATARI JOYSTICK (in the left hand":? "socket) YOU WILL AVOID THE GREEN"
55 ? "DRAGON.":? :? "IF YOU REACH THE CASTLE GATE SAFELY":? "YOUR FORTUNE WILL B
E INCREASED BY"
60 ? "100 GOLD PIECES AND YOU WILL OFFERED":? "A FURTHER RUN.":? :? "WHEN YOU HA
VE 1000 GOLD PIECES LIFE"
65 ? "WILL BECOME MORE DIFFICULT!!!!":? :? "PRESS RETURN WHEN YOU ARE READY FOR
"
70 ? "YOUR CHALLENGE.GOOD LUCK!!!!!!!!":INPUT A$
90 GP=0
100 GRAPHICS 5:SETCOLOR 0,12,6:SETCOLOR 1,3,4:SETCOLOR 2,0,8:SETCOLOR 4,12,2:POK
E 752,1
105 COLOR 3
110 I=15:PLOT I,0:PLOT I+2,0:PLOT I+6,0:PLOT I+8,0:PLOT I,1:DRAWTO I+2,1:PLOT I+
6,1:DRAWTO I+8,1:PLOT I+4,1
120 PLOT I,2:DRAWTO I+8,2:FOR N=3 TO 4:PLOT I,N:DRAWTO I+2,N:PLOT I+6,N:DRAWTO I
+8,N:NEXT N
130 FOR I=1 TO 25:X=INT(76*RND(1)+2):Y=INT(35*RND(1)+3):COLOR 1
140 PLOT X,Y:DRAWTO X+2,Y:PLOT X+1,Y-1:COLOR 2:PLOT X+1,Y+1:NEXT I
145 COLOR 0:I=18:FOR N=3 TO 5:PLOT I,N:DRAWTO I+2,N:NEXT N
149 ? "THE DRAGON HAS SEEN YOU":? "RUN FOR YOUR LIFE!"
150 GOSUB 1500
155 ? "YOUR FORTUNE IS ";GP;" GOLD PIECES":? :?
160 M=X:E=39:D=Y:R=INT(7*RND(1)+30):D1=X:R1=3
170 COLOR 3:PLOT M,E:SOUND 0,0,0,0:IF (M=19) AND (E=4) THEN 1000
180 Z=STICK(0):IF Z=15 THEN 180
181 SOUND 0,0,5,15
182 IF Z=7 THEN 190
183 IF Z=11 THEN 220
184 IF Z=13 THEN 250
185 IF Z=14 THEN 280
186 IF Z=10 THEN 280
187 IF Z=6 THEN 280
188 IF Z=9 THEN 250
189 IF Z=5 THEN 250
190 LOCATE M+1,E,XX:IF XX<>0 THEN 300
200 COLOR 0:PLOT M,E:M=M+1:IF M>78 THEN M=78
205 GOSUB 500
210 GOTO 170
220 LOCATE M-1,E,XX:IF XX<>0 THEN 300
230 COLOR 0:PLOT M,E:M=M-1:IF M<1 THEN M=1
235 GOSUB 500
240 GOTO 170
250 LOCATE M,E+1,XX:IF XX<>0 THEN 300
260 COLOR 0:PLOT M,E:E=E+1:IF E>39 THEN E=39
265 GOSUB 500
267 IF Z=9 THEN 220
268 IF Z=5 THEN 190
270 GOTO 170
280 LOCATE M,E-1,XX:IF XX<>0 THEN 300
290 COLOR 0:PLOT M,E:E=E-1:IF E<1 THEN E=1
293 GOSUB 500
294 IF Z=10 THEN 220
296 IF Z=6 THEN 190
298 GOTO 170

```

## VARIABLES

N\$ and S\$: These strings are concatenated to form players name and give him a title.

Z\$: Replay response (Y or N).

G.P.: Gold pieces.

M,E: Players position.

D,R: Dragon's position.

D1,R1: Second dragons position.

A,B: Dragon movement amendment to D,R.

F,C: Second dragon movement amendment to D1,R1.

Program notes

Line 181: The odd number in the distortion position (SOUND 0,0,5,15) gives a click when the sound is turned on, and a click when turned off. This is used for footsteps.

Line 500: Makes A and B either 1 or -1. These values are used later to modify the dragon's position.

Line 520: Looks to see if there is a tree in the way. If there isn't D and R are modified in line 530. If there is the dragon stays put.

Line 1250: POP is the command to clear the return address as the program has jumped from a subroutine to this line.

The authors say that it should not be too difficult to adapt the program to a one or two player format. One using a joystick to control the dragon — the other controlling the man.

Beware the fire breathing dragon my dears. He'll singe your eyebrows with just a single glance! He's a ravenous beast and will gobble you down as soon as look at you if you let him get near enough.

Once there was a great and brave dragon hunter in these parts who tracked down dragons for gold. Even he couldn't defeat this scaled serpent. He's never

given up and keeps on trying to beat the dragon. But the monster keeps chasing him back to the castle.

The object of this game is to get from the bottom of the screen to the castle at the top using the joystick controller. You are chased by a computer controlled dragon — and if you manage to escape his fiery breath and reach the castle you earn 100

gold coins by way of reward.

The secret of the game lies in the glades and copses of the Dark Forest which bars your way to the castle. Neither you or the dragon can pass through the forest — but if you are tricky enough you can trap the dragon within the trees and race to the castle before it escapes.

If you manage to complete 10 runs and collect 1,000 gold coins

the dragon calls up its mate and you have to deal with two deadly monsters.

You are represented on screen by a white square, the dragon by a green square. The dragon does not appear until you start moving. To slam the castle door you must be positioned exactly in the centre of the castle gateway. And remember you are not safe until that door is shut.

**RUNS ON AN ATARI 400/800 IN 8K**

**BY PETER AND MARK WRIGHT**

# DRAGON RUN



```

300 COLOR 0:PLOT M,E:GOTO 170
500 A=(D<=M)-(D>=M):B=(R<=E)-(R>=E)
510 COLOR 0:PLOT D,R:IF GP>=1000 THEN GOSUB 750
520 LOCATE D+A,R+B,YY:IF (YY=1) OR (YY=2) THEN 540
530 D=D+A:R=R+B
540 COLOR 1:PLOT D,R:IF (D=M) AND (R=E) THEN 1250
550 RETURN
750 COLOR 0:PLOT D1,R1:C=(D1<=M)-(D1>=M):F=(R1<=E)-(R1>=E)
760 LOCATE D1+C,R1+F,ZZ:IF (ZZ=1) OR (ZZ=2) THEN 780
770 D1=D1+C:R1=R1+F
780 COLOR 1:PLOT D1,R1:IF (D1=M) AND (R1=E) THEN 1250
790 RETURN
1000 FOR I=3 TO 4:COLOR 2:PLOT 18,I:DRAWTO 20,I:NEXT I
1005 FOR I=1 TO 5:SOUND 0,255,2,15:NEXT I
1006 FOR I=15 TO 0 STEP -1:SOUND 0,255,2,1:NEXT I:SOUND 0,0,0,0
1010 GP=GP+100:POKE 656,0:? "YOUR FORTUNE IS ";GP;" GOLD PIECES"
1020 FOR I=1 TO 500:NEXT I:GOTO 100
1250 POP
1255 GOSUB 1500
1260 ? "SORRY ";N$;",";":? "YOU'VE JUST BECOME A SQUARE MEAL.
":? "BUT YOU HAD ";G
P;" GOLD PIECES."
1270 ? "ANOTHER GAME (Y or N)";
1274 CLOSE #1
1275 OPEN #1,4,0,"K:":GET #1,A
1276 IF A=89 THEN 90
1290 ? :? :? "THANKS FOR THE GAME ";N$
1300 GOTO 1300

```

```

1500 FOR I=0 TO 15 STEP 1.5:SOUND 0,243,8,I:SOUND 2,INT(15*RND(1)+240),12,I
1510 NEXT I:FOR Z=1 TO 100:NEXT Z:FOR I=15 TO 0 STEP -0.2:SOUND 0,243,8,I:SOUND
2,INT(15*RND(1)+240),12,I:NEXT I
1520 RETURN
2000 GRAPHICS 2+16:SETCOLOR 0,0,15:SETCOLOR 4,15,0
2010 POSITION 5,3:? #6;"D R A G O N":POSITION 5,4:? #6;"-----":POSITION 8,
7:? #6;"R U N":POSITION 8,8:? #6;"-----"
2020 SOUND 1,243,10,1
2050 FOR I=1 TO 4:READ H,K:SETCOLOR 4,15,K:SOUND 0,H,10,15:FOR N=15 TO 0 STEP -0
.2:SOUND 0,H,10,N
2055 NEXT N:NEXT I:SOUND 1,0,0,0
2060 DATA 162,0,162,2,162,4,193,2
2100 RETURN

```

# At last. A range of software that's as well designed as the Dragon 32.

Six months ago, most computer users thought a Dragon was something out of an adventure game.

How times change. Nowadays, it's almost impossible to pick up a computer magazine without reading some new tribute to the Dragon 32.

## THE FIRST FAMILY COMPUTER

We called it the first family computer. And we believe that much of its success derives from the fact that it has been superbly designed for the job it has to do.

Design that incorporates 32K RAM of memory at a real value-for-money price level.

Design that utilises the advanced 6809E microprocessor.

Plus a range of features that help make the world of computers accessible to first-time users. Like colour drawings. 5 octaves of music.

And plenty of power and versatility to keep up the interest as your experience increases.

## SOFTWARE TO MATCH

Designing a range of software that does justice to the Dragon was a task we approached with as much care as designing the computer itself.

The results are now available - games, educational programs, hints on programming - conceived by some of the best software houses in the world, to help users get even more out of their machines.



\*TV not included in price.



Graphic Animator. A cassette that makes use of the Dragon's ability to draw on the screen. It shows you how to create simple cartoons - then bring them to life.



Personal Finance. This cassette allows you to keep track of all the family's finances, from bills to bank statements.



Ghost Attack. On cartridge. You're in a maze, and you must find your way out. But you're not alone - you're pursued by ghosts!



Chess. A great partner to play against again and again - with one major drawback. It's very hard to beat. Test yourself against nine different levels. On cartridge.



Typing Tutor. Only a keyboard as sophisticated as the Dragon's could allow you a program like this. You use the Dragon's own keyboard to learn to type. On cassette.



Cave Hunter. Finding the hidden gold is hard. But surviving the attacks of malevolent creatures may well prove to be impossible. Cave Hunter is on cartridge.



Dragon Selection. A cassette of utility programs, allowing you to create your own database. Write your own tunes - or learn other language vocabularies.



Starship Chameleon. A cartridge game. You find yourself under attack by the dreaded Gabolators! Their task is to take your planet - yours is to protect it.



Computavoice. This cassette actually enables your Dragon to speak to you. These are just some of our titles, and every month, we'll be adding more and more.

What you get out of a computer depends on what you put in. And with a Dragon 32 and Dragon software, there's enough challenge and satisfaction for anyone. But then, that's what it's designed for.

**DRAGON 32**  
The first family computer.



So you think you could be a great Member of Parliament, solving all the problems of the country overnight. Well, try and convince the voters!

This game is played on a board drawn by your computer and can be played by up to five people. The object is to collect as many votes as possible from your constituency. To win you must enter the House of Commons with more than 25,000 votes.

You have to face all the ups and downs of political life and be well prepared for a general election when it is called. There are upsets around every corner — but you could also be surprised by a bit of good fortune which sends your popularity soaring.

So look out your best suit and switch on that winning smile. Who knows, you could become the next Prime Minister!

**BY M. J. COATES**

**RUNS ON A 40 COLUMN PET IN 8K**

# ELECTION







# LEAP INTO THE COMPUTERISED AGE

VISIT OUR BRANCHES AT ROCHFORD AND HORNCHURCH AND SEE THE LARGEST SELECTION OF HOME COMPUTER SOFTWARE AND HARDWARE IN SOUTH ESSEX

**JOIN OUR SOFTWARE CLUB** and save £s. Lifetime membership £20. Your membership fee includes your choice of software to value of £18. You will receive order by return with membership card and your own personal club no. **PLUS 10%** reduction on ALL future orders. We pay all postage and handling costs. For instant membership you may telephone your Access/Barclay/VISA card no.

Agents for Atari, Vic, Dragon, Rabbit, Romik, Bug Byte, Sharp, Texas, Kuma, Nascom, Micro Power, etc.



THE AMAZING ATARI COMPUTERS

## NEW LOW PRICES

**ATARI 400 16K** £195.50

**ATARI 400 48K + BASIC + MANUALS** £319.00

**ATARI 800 48K + BASIC + MANUALS** £495.95

**ATARI 800 16K + BASIC + MANUALS** £395.95

### Learn Programming

Invitation to Programming 1	£15.95
Invitation to Programming 2	£22.95
Invitation to Programming 3	£22.95
Basics of Animation	£11.95
Player Missile Graphics	£18.95
Display Lists	£11.95
Horiz/Vert Scrolling	£11.95
Page Flipping	£11.95
Sounds & Music	£11.95
Tricky Tutorials	£59.95

### Business Programs

Atari Word Processor	£99.95
Mini Word Processor	£11.95
Graph-It	£13.95

Statistics	£13.95	Datestones of Ryn	£14.95	The Count	£14.95
Mortgage & Loan Analysis	£13.95	Star Warrior	£28.95	Strange Odyssey	£14.95
Bob's Business	£9.95	Invasion Orion	£18.95	Mystery Fun House	£14.95
<b>Utilities</b>		Star Trek 3.5	£14.95	Pyramid of Doom	£14.95
Programming Ads Package 1	£9.95	Crush, Crumble & Chomp	£22.45	Ghost Town	£14.95
6502 Disassembler	£9.95	Temple of Apschai (Part 1)	£28.95	Savage Island I	£14.95
3D Supergraphics	£29.95	Upper Reaches of Apschai (Part 2)	£14.95	Savage Island II	£14.95
Telelink	£21.50	Curse of Ra (Part 3)	£14.95	Golden Voyage	£14.95
<b>Adventure Games</b>		Adventure Land	£14.95	The Battle of Shiloh	£29.95
Galactic Empire	£14.95	Pirates Adventure	£14.95	Energy Czar	£9.95
Rescue at Rigel	£22.45	Mission Impossible	£14.95	Kingdom	£9.95
		Voodoo Castle	£14.95	Plus! Arcade Games, Home Game Programs, Music Programs, etc. etc.	

## VIC 20 £139.95



### Hardware

VIC 20 Console	£169.99
C2N Cassette Unit	£44.95
VIC Printer	£230.00
VIC Disk Drive	£396.00
3K RAM Cartridge	£29.95
8K RAM Cartridge	£44.95
16K RAM Cartridge	£74.95

### Joysticks and Paddles

Single Joystick	£7.50
Pair of Joysticks	£13.95
Le Stick	£24.95
Pair of Paddles	£13.95

### Programming Aid Cartridge

Super Expander 3K RAM and Hi res graphics	£34.95
Programming Aid Additional commands, function key programming etc.	£34.95
Machine Code Monitor	£34.95

### Software (all 3K unless stated)

Introduction to BASIC Cassettes	
Part 1	£14.95
Part 2	£14.95

### Game Programs

Avenger Cartridge	£19.95
Star Battle Cartridge	£19.95
Super Slot Cartridge	£19.95
Jelly Monsters Cartridge	£19.95
Alien Cartridge	£19.95
Super Lander Cartridge	£19.95
Road Race Cartridge	£19.95
Rat Race Cartridge	£19.95
Blitz Cassette	£4.99
Mole Attack Cartridge	£24.95
Adventureland Cartridge	£24.95
Pirate Cove Cartridge	£24.95
Mission Impossible Cartridge	£24.95
Voodoo Castle Cartridge	£24.95
The Count Cartridge	£24.95
Sargon 2 Chess Cartridge	£24.95
Golf Cartridge	£24.95
Omega Race Cartridge	£24.95
Another VIC in The Wall Cassette	£7.00
VIC Panic Cassette	£7.00
Cosmiads Cassette	£7.00
Backgammon Cassette (+3K)	£7.00
VIC Men Cassette	£7.00
VIC Asteroids Cassette	£7.00

### Business Programs

Simplicalc Disk (+16K)	£24.95
Simplicalc Cassette (+16K)	£19.95

VIC Stock Control Cassette (+8K)	£19.95
VIC File Disk (+16K)	£24.95
VIC Writer Disk (+8K)	£24.95
VIC Writer Cassette (+8K)	£19.95

### Education (CSE & GCE O Level Revision)

All cassette based and require at least 8K expansion memory	
English Language	£9.99
Mathematics 1	£9.99
Mathematics 2	£9.99
Biology	£9.99
Chemistry	£9.99
Physics	£9.99
Computer Studies	£9.99
Geography	£9.99
History	£9.99
Arithmetic for 9 to 11 year olds	£9.99
Reading for 9 to 11 year olds	£9.99
General Knowledge for 9 to 11 year olds	£9.99
Spelling for 9 to 11 year olds	£9.99

### Home Programs

All cassette based and require at least 8K expansion memory	
Quizmaster	£9.99
Know Your Own IQ	£9.99
Junior IQ	£9.99

Know Your Own Personality	£9.99
The Robert Carter Family Menu Planner	£9.99



### SPECTRUM COMPUTER GROUP MEMBER

(MAIL ORDER)  
174 HIGH STREET,  
HORNCHURCH,  
ESSEX, 04024 75613

17 GOLDEN CROSS PARADE,  
(MANSTON GARDENS),  
ASHINGDON ROAD,  
ROCHFORD, 0702 540455



```

70 PRINTC$;N$(P);", YOUR GO";
C$;"PRESS SPACE"
71 GETA$:IFA$("<" THEN71
72 GOSUB50:GOSUB126
73 Z=P(P)+D:IFZ>22THENZ=Z-22
74 GOSUB127
75 PRINTD$(0):PRINTC$;"||";S$(Z)
76 V=Q(Z)
77 IFV=9THENV(P)=INT(V(P)/2):V=0
78 IFV=99THENGOSUB91:V=0
79 IFV=5THENGOSUB99:V=0
80 IFV=66THENGOSUB114:V=0
81 IFV=77THENS(P)=INT(S(P)*1.2):V=0
82 IFV=88THENM(P)=M(P)+S(P):V=0
83 V(P)=V(P)+V:M(P)=M(P)+M1(Z)
84 IFV(P)<0THENV(P)=0
85 IFM(P)<0THENGOSUB154
86 GOSUB132
87 GOSUB149
88 GOSUB50
89 NEXTP:GOTO68
90 GOSUB153:GOTO72
91 IFV(P)<25000THENRETURN
92 PRINTC$;"YOU HAVE OVER 25000 VOTES"
93 GOSUB152:GOSUB152
94 PRINTC$;"THAT MEANS YOU ARE ELECTED"
95 GOSUB152:GOSUB152
96 PRINTC$;"
97 PRINTC$;"WELL DONE ";N$(P)
98 PRINTC$;"AND HARD LUCK THE REST":END
99 D$="SOUTHENDLEIGH CANVEY BENFLEETBASILDONPITSEA GRAYS OCKENDON"
100 GOSUB152
101 E$=MID$(D$,(INT(RND(1)*8)*8+1),8)
102 PRINT"BY ELECTION AT "E$
103 FORBE=1TO5:PRINT"":FOREB=BETO1STEP-1:PRINT" ";
104 NEXT:PRINTN$(BE);TAB(10);P$(BE):NEXT
105 GOSUB153
106 FORBE=1TO5:PRINT"":FOREB=BETO1STEP-1:PRINT" ";:NEXT
107 V2(BE)=INT(1000+RND(1)*500+RND(1)*500):PRINTTAB(15);V2(BE)
108 V(BE)=V(BE)+V2(BE):NEXT
109 PRINT"PRESS SPACE TO CONTINUE"
110 GETA$:IFA$("<" THEN110
111 GOSUB51:GOSUB149
112 FORI=1TO5:POKEA(P(I))+D(I),N(I):NEXT
113 GOTO132
114 GOSUB152
115 IFP>NTHEN135
116 PRINTC$;"|| HOW MUCH DO YOU WISH TO PAYFOR THEIR SERVICE";
117 INPUTPA$:PA=VAL(PA$):IFPA=0THENRETURN

```



```

118 IFPA>M(P)THEN123
119 V2=0:V=INT(PA/10):FORV1=1TOV:V2=V2+INT(RND(1)*100+1):NEXT
120 GOSUB50
121 PRINTC$;"YOU GAIN";V2;"VOTES":V(P)=V(P)+V2:M(P)=M(P)-PA
122 GOTO152
123 GOSUB50:PRINTC$"YOU CAN ONLY AFFORD";M(P)
124 PRINTC$;"IF YOU DO NOT WANT A P.R FIRM"*****"THEN ANSWER 0"
125 GOTO114
126 FORK=1TO30:D=INT(RND(1)*6+1):PRINTD$(0):PRINTD$(D):NEXT:RETURN
127 IFZ<P(P)THENM(P)=M(P)+S(P):GOTO130
128 FORM=P(P)TO2:POKEA(M)+D(P),N(P):G=M-1:IFM=1THENG=22
129 POKEA(G)+D(P),32:GOSUB153:NEXT:P(P)=Z:RETURN
130 FORM=P(P)TO22:POKEA(M)+D(P),N(P):POKEA(M-1)+D(P),32
131 GOSUB153:NEXT:P(P)=1:GOTO128
132 FORI=0TO29:X=PEEK(33053+P*40+I)
133 X=X+128+(X>127)*256
134 POKE33053+P*40+I,X:NEXT:RETURN
135 PA=INT(RND(1)*M(P)):PRINTC$;"I WILL PAY $";PA
136 FORI=1TO500:NEXT:GOTO119
137 POKE59468,14
138 PRINT"J"
139 PRINT"THIS IS THE GAME OF 'L-1,7//. THE"
140 PRINT"OBJECT OF THE GAME IS TO COLLECT VOTES FROM YOUR CONSTITUENCY.
141 PRINT"TO WIN , YOU MUST ENTER THE HOUSE OF COMMONS WITH MORE THAN";
142 PRINT" 25000 VOTES.
143 PRINT"IF YOU LAND ON AN 'L-1,7// SQUARE THEN
144 PRINT"AN ELECTION WILL BE HELD.
145 PRINT"UP TO 5 PEOPLE CAN PLAY , WITH ME ACTINGAS ANY EXTRAS REQUIRED.
146 PRINT"***";TAB(7);"L-1,7// 1/1'11F -T/1,7// "
147 GETA$:IFA$=""THEN147
148 PRINT"J":RETURN
149 FORI=1TO5:PRINTM$(I);"
150 PRINTM$(I);N$(I);M$(I);M$;P$(I);M$(I);M1$;M(I)
151 PRINTM$(I);M1$;"$";M$(I);M2$;V(I):NEXT:RETURN
152 FORI=1TO1E3:NEXT:RETURN
153 FORI=1TO500:NEXT:RETURN
154 GOSUB152:GOSUB50
155 PRINTC$;"BANKRUPT...BACK TO BEGINNING":M(P)=0:V(P)=0:POKEA(P(P))+D(P),32
156 P(P)=1:POKEA(1)+D(P),N(P):GOTO152

```



# MYSTERIOUS ADVENTURES



FOR BBC MICROCOMPUTER MODELS A & B\*

Join the growing band of Adventurers who are enjoying these absorbing and stimulating programs. Step into another world of Fantasy, Magic, Mystery and Sorcery. Only your wits and cunning can ensure success in these scenarios!



- WRITTEN IN ULTRA-FAST MACHINE CODE.
- SAVE GAME FEATURE.
- SPLIT SCREEN DISPLAY.

1. THE GOLDEN BATON — Venture into a strange province of Sorcery and Evil Magic to recover the Golden Baton, a priceless artifact whose powers are said to bring great Health and Prosperity to the Land.
2. THE TIME MACHINE — As a Newspaper reporter you are sent to investigate the eccentric professor who lives in the old house on the Moors. What is his secret and why is his house now deserted?
3. ARROW OF DEATH (Pt. 1) — A blight has fallen on your homelands, the Baton has become tarnished and now radiates a malevolent aura of Evil. Your mission is clear — trace the source of this Evil and destroy... or be destroyed. This is the first part of an Epic Adventure although each part can be played as a stand alone scenario.
4. ARROW OF DEATH (Pt. 2) — You now have the means to destroy your enemy... but you are far from home and this land is strange to you. Can you cope with the deadly perils which approach you and have you the strength to see your mission through to the final conflict?
5. ESCAPE FROM PULSAR 7 — Alone on a gigantic Space-Freighter... The rest of your crew have died horribly at the hands of a mutated Zoo-Specimen. Your only chance of escape is to reach the Frail Shuttlecraft. But the lurking Monster is hungry and you are the only food it has left...
6. CIRCUS — Your Car has run out of Petrol on a lonely road miles from habitation. As you trudge reluctantly down the road in search of help you are suddenly confronted by an amazing sight... in a nearby field is a Huge Circus tent! But this is no ordinary Circus as you will soon discover...
7. FEASIBILITY EXPERIMENT — Far across the gulfs of time and space, a dying race of super-intelligent beings search the Universe for a Hero to save their existence... At length their thoughts turn to planet Earth. You are chosen to be their saviour in a bizarre scenario where death is a mere thought away...
8. THE WIZARD OF AKYRZ — You are in the Royal Palace. The King beseeches you to rescue his daughter from the evil wizard. If you succeed your reward will be priceless... failure will bring certain death.
9. PERSEUS AND ANDROMEDA — Travel into the realms of ancient mythology. Battle with grotesque monsters and supernatural powers as you search for the hidden secrets of myth and legend.
10. TEN LITTLE INDIANS — This mystery begins with a train journey into a strange country. What secrets are held by the strange country mansion? What meaning is attached to the strange idols? Maybe you will find out if you live long enough...

\* Adventures 5, 6 and 7 require 32K RAM

Each adventure comes attractively packaged for just £8.95 inc.

Now in stock for ATARI 400/800 £12.50

Available soon for ZX SPECTRUM, ZX81 (16K), APPLE II.



SEND CHEQUE OR P.O. TO:

**DIGITAL  
FANTASIA** DEPT DWL,  
24 NORBRECK ROAD, NORBRECK, BLACKPOOL, LANCASHIRE.  
Tel: (0253) 591402

# All the best sellers...

For all home micro-users who don't live near one of the larger city branches of Boots or W. H. Smith, and who find difficulty in purchasing the very latest, best-selling software - here is the answer!

Software Express is the new, mail-order arm of a £12 million group of companies. We have just signed an agreement with Bug-Byte, Britain's most successful software house, to supply their exciting products direct to you, the user. New and original games for the ZX81, Spectrum, BBC Micro, VIC 20 and Oric 1 can be delivered to your door AT SHOP PRICES. That's right, positively no extra charges - we even pay the postage both ways!

All you have to do is make your selection from the items listed on this page, complete the easy reply coupon, and send it to our FREEPOST address (no stamp required), enclosing your cheque, postal order, or credit card number for the appropriate amount. Alternatively, you may place your order on our 24 hour Ansaphone by phoning in your Access/Barclaycard number with your name, address and details of your order.

The cassettes of your choice will be mailed to you quickly and efficiently. No cheques will be cashed prior to despatch of your order, and if for any reason you are not satisfied with your purchase, we will give you a full refund just as quickly.

It's so simple! The best quality software, promptly and conveniently at no extra cost from Software Express. Try us and see for yourself - we go out of our way especially for you.

**BEST SELLER**

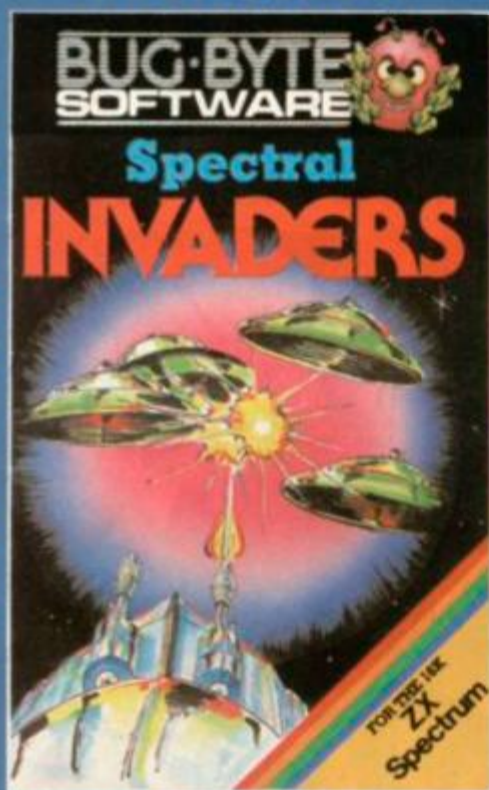

**PRICE £5**

FOR THE ZX SPECTRUM

FOR THE ZX SPECTRUM

**BEST SELLER**



**PRICE £8**

FOR THE ZX SPECTRUM

FOR THE ZX SPECTRUM

**NEW IMPROVED VERSION**

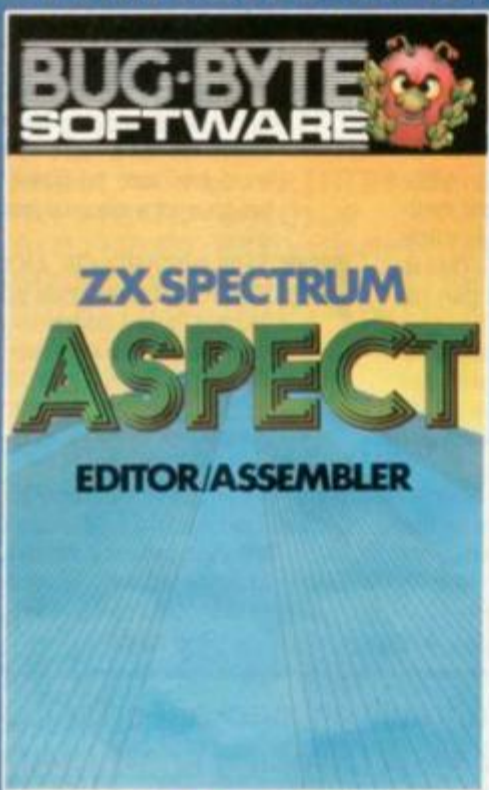

**PRICE £9**

FOR THE ZX SPECTRUM

FOR THE ZX SPECTRUM

**BRAND NEW PROGRAM**

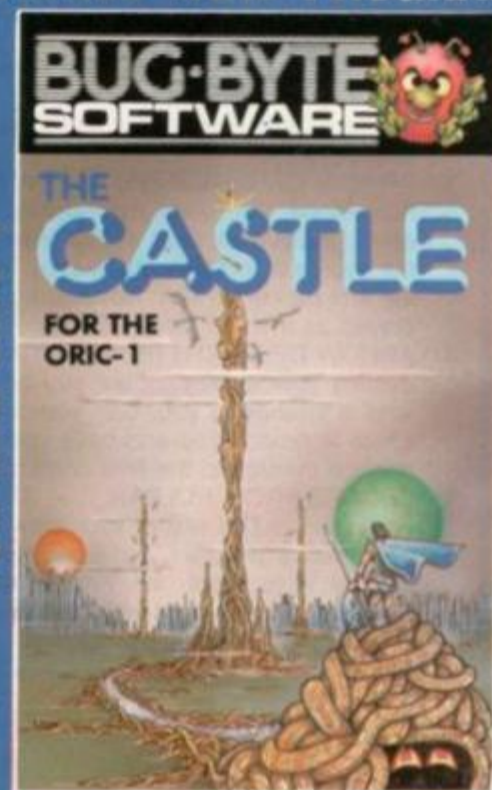

**PRICE £8**

FOR THE ORIC 1

FOR THE ORIC 1

**OTHER TITLES AVAILABLE FROM SOFTWARE EXPRESS...**

**FOR THE VIC 20...**

VIC Chess - £7. VIC Asteroids - £7. VIC Panic - £7.  
VIC Cosmiads - £7. Another VIC in the Wall - £7.  
VIC Backgammon - £7. VIC Scramble - £7.  
All programs are for the unexpanded VIC 20,  
with the exception of Chess (16K) and  
Backgammon (min. 3K expansion).

**FOR THE ZX81...**

Mazogs - £10. Dictator - £9. Invaders - £4.  
ZXAS (Z80 Assembler) - £5.  
ZXDB (Z80 Debugger) - £6.50.  
ZXTK (Z80 Toolkit) - £6.  
(all programs are for the 16K - ZX81).

Only programs listed on this advertisement are available from Software Express. For other items in the Bug-Byte Catalogue see your nearest dealer.

All dealer enquiries to: Bug-Byte Software, 100 The Albany, Old Hall Street, Liverpool L3 9EP.

# ...direct to your door!

ALL TIME FAVOURITE



FOR THE BBC MICRO

FOR THE BBC MICRO

PRICE £7.50

NEW PROGRAM

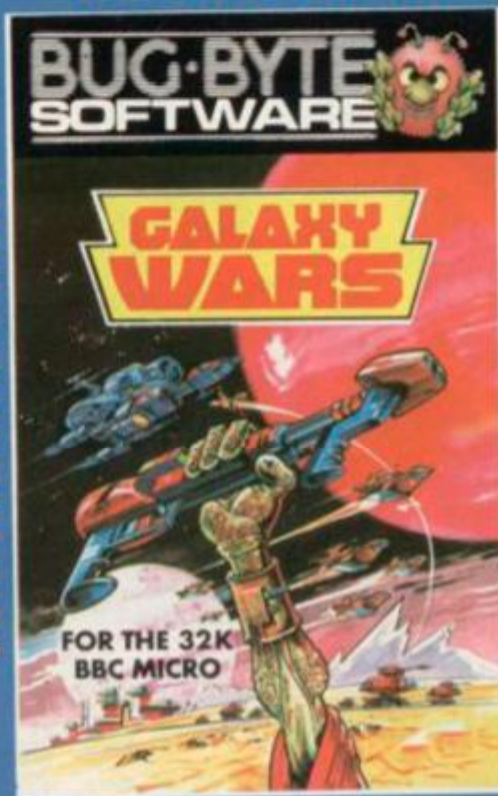

FOR THE BBC MICRO

FOR THE BBC MICRO

PRICE £7.50

NEW PROGRAM

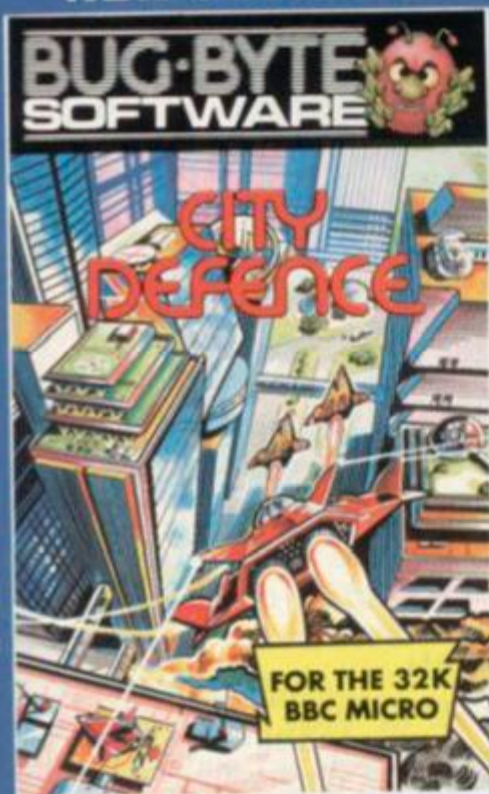

FOR THE BBC MICRO

FOR THE BBC MICRO

PRICE £7.50

NEW PROGRAM



FOR THE BBC MICRO

FOR THE BBC MICRO

PRICE £9.50

## THE SOFTWARE EXPRESS EASY-REPLY COUPON

Please mail me the following Software Cassettes.  
(All prices include VAT and postage).

PROGRAM	PRICE	INSERT QUANTITY
SPECTRAL INVADERS	£5	
SPECTRES	£8	
ASPECT	£9	
THE CASTLE	£8	
SPACE INVADERS	£7.50	
GALAXY WARS	£7.50	
CITY DEFENCE	£7.50	
MUSIC SYNTHESIZER + AUTO COMPOSER	£9.50	
OTHER ITEMS		

TOTAL PRICE £

I enclose cheque/P.O. for \_\_\_\_\_

Or please charge my Credit Card No. \_\_\_\_\_



Access/ Barclaycard only please.



24 HOUR ANSAPHONE FOR CREDIT CARD ORDERS:

051-548 2020

Mail to:

SOFTWARE EXPRESS  
FREEPOST  
(No Stamp Required)  
Gores Road,  
Kirkby Industrial Estate,  
Kirkby, Liverpool  
L33 7UA.

# SOFTWARE EXPRESS

FREEPOST (No Stamp Required). Gores Road, Kirkby Industrial Estate, Kirkby, Liverpool L33 7UA.  
Software Express is a trading name of DAMS Office Equipment Liverpool.

Illustration: Terry Rogers

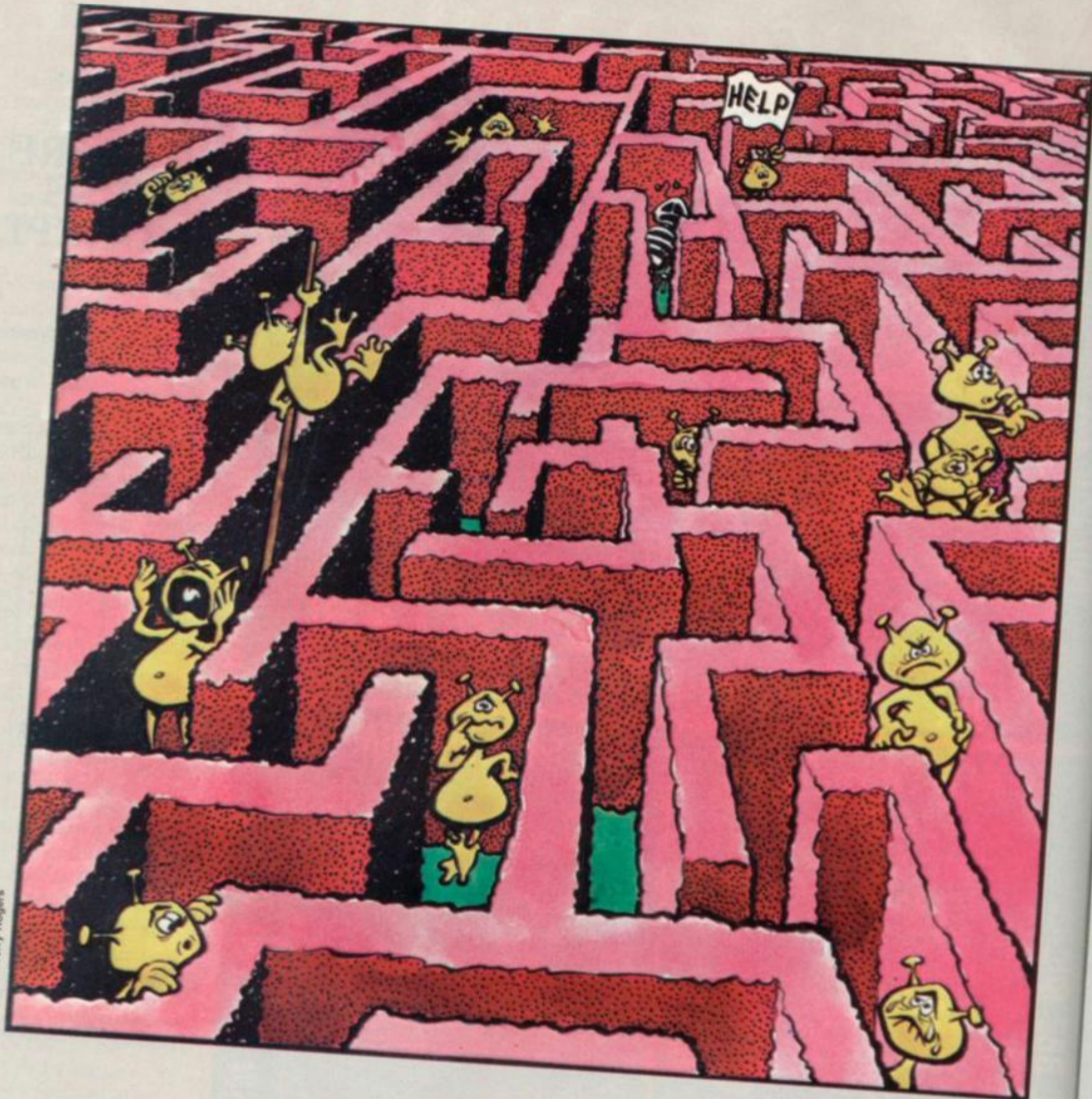

#### PROGRAM NOTES

##### LINE NUMBER DESCRIPTION

10-50 Set up variables and arrays.  
60 Start of main program loop.  
70 Input skill level.  
80-190 Set up screen and start game.  
200 Print out high score. N.B. LI.F FE22 blanks current line. ?E EO=21 sets cursor to 21st column in the line.  
210 Set initial direction.  
220 Start of game playing loop.  
230-260 Scan keyboard.

##### LINE NUMBER DESCRIPTION

270-330 Calculate new position.  
340-390 Test new position and act accordingly.  
400 Delay depending upon skill level.  
410-440 End game and adjust high score.  
450 End of main loop.  
460 Question mark hunting subroutine.  
470-560 Kill subroutine instructions.  
570-630 Assemble machine code sound generator.  
640-710



```

10 X=#7F;Q=#BF
20 S=#0000;B=#0000;H=0;Z=#00
30 DIM C3,SS2,P-1
40 GOS.1
50 C70=32;C71=X;C72=Q;C73=#FF
60 DO P,#12
70 DO IN."SKILL LEVEL (1-5)"W;U.W>0 AND W<6
80 N=0;T=0;@=0;A=3
90 CLEAR0;MOVE 0,43;DRAW 63,43
100 ?#E1=0
110 F,J=64 TO 511
120 R=R.R.%4
130 N=N+(R=1 OR R=2)
140 S7J=C7R
150 N.J
160 P=272;S7P=171
170 P.#30" Press"#128"any"#128"key"#128"to"#128"start"
180 LI.#FFE3
190 Y=10;F,J=100 TO 1 S.-1;?Z=J;LI.SS0;N.J
200 P.#30;LI.#FE22;?#E0=21;P."HIGH: ",H
210 F=1
220 DO D=0
230 ?B=2;IF B71=254;D=32
240 ?B=3;IF B71=254;D=-32
250 ?B=1;D=D-(B71=251)
260 ?B=9;D=D+(B71=247)
270 IF D=0;D=F
280 F=D
290 L=P;P=P+D
300 IF P%32=0 AND L%32=31;P=P-32
310 IF P%32=31 AND L%32=0;P=P+32
320 IF P<64;P=P+448
330 IF P>511;P=P-448
340 WAIT;V=S7P
350 IF V=Q;GOS.1
360 IF V=X;T=T+5+2*W;N=N-1;?Z=40;Y=40;LI.SS0

```

```

370 IF V=#FF;GOS.k
380 WAIT;S7L=32;WAIT;S7P=171
390 P.#30"SCORE: "T," LIVES: "R
400 F,J=1 TO 15-W*3;WAIT;N.
410 U.N=0 OR A=0
420 Y=10;F,J=1 TO 100;?Z=J;LI.SS0;N.J
430 ?B=0
440 IF T>H;H=T
450 LI.#FFE3;U.0
460 IF A.R.%5;T=T+10+4*W;N=N-1;?Z=30;Y=40;LI.SS0;R.
470 R=A-1
480 WAIT;S7L=32
490 ?Z=0;Y=150;LI.SS0
500 F,J=1 TO 4
510 WAIT;S7P=V
520 F,K=1 TO 150;N.K
530 WAIT;S7P=171
540 F,K=1 TO 150;N.K
550 N.J
560 F,J=1 TO 150;N.J;R.
570 P.#12" blockbuster""
580 P.#FF"....SINGLE SCORE""
590 P.#9F"....DOUBLE SCORE, 20% RISK""
600 P.#DF"....AVOID AT ALL COSTS!""
610 P."CONTROLS: ""
620 P."CURSOR KEYS...UP & DOWN""
630 P." < >...LEFT & RIGHT""
640 SS0=-1;SS1=-1;SS2=-1
650 P.#21
660 L
670 SS0 LDA B+2
680 SS1 LDX Z
690 SS2 DEX;NOP;NOP;BNE SS2;EOR @4; STA B+2;DEY;BNE SS1;RTS
700 J
710 P.#6;LI.#FFE3;R.

```

RUNS ON AN ATOM IN 4K

# BLOCKBUSTER

BY CHRIS CYTERA

Trapped within a vast maze built with solid blocks of some strange alien substance on a weird and wonderful planet, you must navigate your way to freedom or else be doomed to wander the labyrinth forever!

That's the challenge of Blockbuster, an original little diversion with some interesting twists — and turns!

In this fast moving game you control an inverted cross — that just can't keep

still. So to keep up with the action you need a fast mind and dancing fingers!

You can smash the white blocks with a well aimed swipe, but avoid the grey blocks at all costs — contact with one of these will end one of your three lives. You can take a chance with the blocks branded with an inverted question mark — if you manage to smash one you'll get double points, but there's a calculated risk that it could wipe you out.

The bouncing cross can

be controlled by using the cursor control keys for up-down movements and the inequality keys (<>) for right and left. Holding down a horizontal and vertical direction key at the same time enables you to move diagonally.

Your current score, lives remaining and the high-score are displayed at the top of the screen.

If your Atom has a colour card there is an additional bonus — the blocks come in different colours.

Chomp, munch, slurp... burp! Oh, excuse me! I can't stop long because I've got a dinner date with these two tasty looking ghosts I met down at the Programmers Arms last night.

They invited me up to their maze to see their dot collection. Why not, I thought...

This version of the arcade classic follows the regular theme. The happy eater munches his way around a maze — avoiding the hungry ghosts.

These ghosts are randomly guided and are not particularly energetic, tending to frequent one particular part of the maze. However, they are capable of a quick sprint

down the corridors when you least expect it!

The best tactic is to munch your way around as close to the ghosts as possible at the start of each new maze, as the ghosts are as hungry for dots as you are.

You score one point for each dot consumed, and once you've cleared one maze a new one is provided. The ghosts start each new maze at a random position and you continue where you left off.

There are two skill levels and if you manage to, munch your way through seven mazes at level one you automatically move up to level two. Control keys are the 'W', 'X', 'A' and 'O' keys.



# PACMAN

RUNS ON A BBC MODEL A IN 16K

BY MARK CLEWETT

```

10REM***PACMAN***
20REM***BY MARK CLEWETT***
30REM***11/10/82***
40MODE7
50PROCintro
60MODE 7
70PROCinit
80PROCinit2
90PROCmaze
100PROCdots
110PROCghosts
120PROCpacmove
130END
140REM#ONE DATA LINE = ONE TEXT LINE#
150REM#EACH NO. IS ONE VDU CHAR.#
160DATADX,188,172,172,172,172,172,172,172,172,172,172,
172,172,172,172,172,172,172,172,172,172,172,172,172,
172,172,172,172,172,172,172,172,172,172,236
170DATADX,181,160,160,160,160,160,160,160,160,160,160,
160,160,160,160,160,160,160,160,160,160,160,160,160,
160,160,160,160,160,160,160,160,160,160,234
180DATADX,181,160,188,172,180,160,188,172,172,180,160,
188,172,172,172,180,160,232,180,160,188,172,172,180,
160,188,172,172,172,180,160,188,172,180,160,234
190DATADX,181,160,181,188,165,160,173,172,252,188,165,160,
173,172,172,236,181,160,234,181,160,253,188,172,172,165,
160,173,252,188,172,165,160,173,180,181,160,234
200DATADX,181,160,173,165,160,160,160,160,175,165,160,160,

```

```

160,160,160,170,165,160,170,165,160,175,165,160,160,160,
160,160,175,165,160,160,160,160,173,165,160,234
210DATADX,181,160,160,160,160,160,180,160,160,160,160,188,
172,180,160,160,160,160,160,160,160,160,160,188,172,
180,160,160,160,160,160,180,160,160,160,160,234
220DATADX,181,160,180,160,188,173,180,160,188,172,172,165,
160,181,160,188,172,172,172,172,172,180,160,181,160,
173,172,172,180,160,188,173,180,160,188,172,172,165,
230DATADX,181,160,165,160,173,172,165,160,173,172,172,
172,165,160,181,160,160,160,160,160,160,181,160,173,172,
172,172,172,165,160,173,172,165,160,165,160,234
240DATADX,181,160,160,160,160,160,160,160,160,160,160,160,
160,160,160,181,160,160,160,160,160,160,181,160,160,160,
160,160,160,160,160,160,160,160,160,160,160,234
250DATADX,181,160,160,160,160,160,160,160,160,160,160,234
172,180,160,181,160,160,160,160,160,160,181,160,188,172,
172,172,172,180,160,188,172,180,160,160,160,160,160,172,
260DATADX,181,160,181,160,173,188,165,160,173,172,172,236,
160,181,160,173,172,172,172,172,165,160,181,160,234
188,172,172,165,160,173,188,165,160,181,160,234
270DATADX,181,160,160,160,160,160,160,160,160,160,160,160,
172,165,160,160,160,160,160,160,160,160,160,160,160,170,
165,160,160,160,160,160,160,160,160,160,252,180,160,160,
280DATADX,181,160,188,180,160,160,160,160,160,160,160,160,
160,160,160,232,180,160,252,180,160,160,160,160,
160,160,252,180,160,160,160,188,180,160,234

```

Illustrations: Terry Rogers

```

290DATADZ,181,160,181,173,180,160,188,172,175,173,180,160,
188,172,172,174,181,160,234,181,160,191,173,172,172,180,
160,188,175,173,172,180,160,188,165,181,160,234
300DATADZ,181,160,173,172,165,160,173,172,172,172,165,160,
173,172,172,172,165,160,170,165,160,173,172,172,172,165,
160,173,172,172,172,165,160,173,172,165,160,234
310DATADZ,181,160,160,160,160,160,160,160,160,160,160,160,
160,160,160,160,160,160,160,160,160,160,160,160,160,160,
160,160,160,160,160,160,160,160,160,160,234
320DATADZ,173,172,172,172,172,172,172,172,172,172,172,172,
172,172,172,172,172,172,172,172,172,172,172,172,172,172,
172,172,172,172,172,172,172,172,172,172,174
330DEFPROCinit
340DIMK(39):HSC=0:AZ=160:BZ=320:CZ=10
350PX=251
360ENDPROC
370DEFPROCinit2
380VDU 23;B202;0;0;0
390XZ=20:YZ=14:DZ=144:SC=0:BSC=0:SHEET=1
400FX11,8
410FX12,8
420ENDPROC
430DEFPROCdots
440FORI=2 TO 37
450FORJ=4 TO 18
460IFSX=13 AND TX=9 THEN 520
470IFSX=26 AND TX=13 THEN 520
480IFSX=13 AND TX=13 THEN 520
490IFSX=26 AND TX=9 THEN 520
500IFSX>16 AND SX<23 AND TX>9 AND TX<13 THEN 520
510IF?(HIMEM+SZ+TX*40)=160 THEN PRINTTAB(SZ, TX);CHR$(164)
520NEXT
530NEXT
540ENDPROC
550DEFPROCmaze
555IF SHEET>7 THEN SKILL=2
560DZ=DZ+1
570IF DZ=152 THEN DZ=145
580PRINT
590NZ=3
600FORIZ=AZ TO BZ STEP CZ
610RESTORE IZ
620FORJZ=0T03B:READK(JZ):NEXT
630FORJZ=0T03B:MZ=K(JZ)
640PRINTTAB(JZ,NZ);CHR$(MZ)
650NEXT
660NZ=NZ+1
670NEXT
680ENDPROC
690DEFPROCscore
700PRINTTAB(0,20);CHR$(141)"SCORE ";SC
710PRINTTAB(0,21);CHR$(141)"SCORE ";SC
720PRINTTAB(20,20);CHR$(141)"HI-SCORE ";HSC
730PRINTTAB(20,21);CHR$(141)"HI-SCORE ";HSC
740ENDPROC
750DEFPROCpacmove
760PRINTTAB(XZ,YZ);CHR$(PX)
770PROCscore
780PROCghostmove
790IF SKILL=2 THEN PROCghostmove
800A$=INKEY$(0)
810FX15,1

```



```

820X1=XZ:Y1=YZ
830IFA$="W" YZ=YZ-1:GOTO880
840IFA$="X" YZ=YZ+1:GOTO880
850IFA$="A" XZ=XZ-1:PX=251:GOTO880
860IFA$="D" XZ=XZ+1:PX=247:GOTO880
870GOTO920
880IF?(HIMEM+XZ+YZ*40)=223 OR ?(HIMEM+XZ+YZ*40)=192 THEN PROCdead
890IF?(HIMEM+XZ+YZ*40)<>160 THEN 900 ELSE GOTO910
900IF?(HIMEM+XZ+YZ*40)=164 THEN SC=SC+1: SOUND 0,-15,2,2 ELSE XZ=X1:
YZ=Y1:GOTO920
910PRINTTAB(X1,Y1);CHR$(160)
920IF (SC+BSC)/SHEET=263 THEN SHEET=SHEET+1:CLS:GOTO90ELSE GOTO 760
930ENDPROC
940DEFPROCend
950PRINTTAB(0,20);CHR$(141);CHR$(134);CHR$(136);"SCORE ";SC
960PRINTTAB(0,21);CHR$(141);CHR$(134);CHR$(136);"SCORE ";SC
970IF SC>HSC THEN HSC=SC
980PRINTTAB(20,20);CHR$(141);CHR$(134);CHR$(136);"HI-SCORE ";HSC
990PRINTTAB(20,21);CHR$(141);CHR$(134);CHR$(136);"HI-SCORE ";HSC
1000PRINTTAB(XZ,YZ);CHR$(PX);TAB(0,23)
1010FX12,0
1020ENDPROC
1030DEFPROCghosts
1040U1=RND(35)+2:V1=RND(15)+3:IF U1>17AND U1<22 OR V1>9 AND V1<11
OR U1=13 AND V1=9 THEN GOTO1040
1050IF?(HIMEM+U1+V1*40)<>164GOTO1040
1060U2=RND(35)+2:V2=RND(15)+3:IF U2>17AND U2<22 OR V2>9 AND V2<11
OR U2=13 AND V2=9 THEN GOTO1060
1070IF?(HIMEM+U2+V2*40)<>164 THEN GOTO1060
1080PRINTTAB(U1,V1);CHR$(223);TAB(U2,V2);CHR$(192)

```

# ROMIK SOFTWARE

24 Church Street, Slough SL1 1PT. Telephone: Slough (STD 0753) 71535



ROMIK PROMISE  
A MINIMUM OF  
ONE NEW GAME  
EVERY MONTH

## STRATEGIC COMMAND

by Alan J. Owens

For the Dragon Computer.

As the name suggests Strategic Command is a game of strategy for two players, the object of which is to overrun the opponents capital. Each player has a capital that contains: 2 battleships, 3 destroyers, 1 aircraft carrier, 2 cruisers, 1 heavy artillery gun, 2 light tanks, 2 main battle tanks, 1 mechanised infantry unit. Each player also has a naval base with: 1 battleship, 2 destroyers, 1 aircraft carrier, 1 mine layer, 2 mine sweepers, 2 submarines, 3 patrol boats, 3 cruisers.

Each player also has an army base with: 1 mine layer, 2 light artillery guns, 2 mine sweepers, 1 main battle tank, 3 mechanised infantry units, 2 light tanks, 1 heavy artillery gun, 3 reconnaissance units. Each player can create up to ten task forces, of up to three units at any one time, mine fields can be laid, and swept, naval forces can engage, or be engaged by land forces if they come close enough, and up to three task forces from each side can engage each other in battle. There is also an air reconnaissance facility.

The game takes a few minutes to learn, but can take anything from a few minutes, to several hours to play, depending on the skill of the players.

## MULTISOUND SYNTHESISER

by Darren Hall

For the unexpanded VIC 20 (in machine code of course) the synthesiser is split into four main sections. 1, normal; 2, normal with drum; 3, programmable background music; 4, white noise. Each section is accessed by pressing one of the four function keys.

Music can be played like a normal organ or synthesiser by using the 2 rows of keys "Q" to "Z" & "A" to "P". By pressing certain keys, different harmonics and sound effects may be created. Up to 4 tunes of up to 255 notes each can be created as background music, and can be saved to tape for reloading at a later date. A background tune plus the drum beat (choice of 6) can be played together, and at the same time you can play another tune over the top, the rhythm can be speeded up or slowed down, etc., etc., etc.

## SPACE ATTACK

by Cliff Ramshaw

For the unexpanded VIC 20.

Space Attack is a machine code arcade quality game with extremely good graphics, and 3 starting skill levels.

There are four different waves of different alien space ships, which attack you (as the pilot of an inter galactic battleship) with increasing speed and ferocity, each wave coming faster than the last, and shoot in up to three different directions as they attack, making dodging them extremely difficult, you more or less have to keep firing and moving all the time.

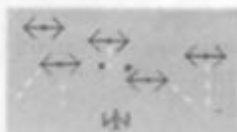

## SPACE FORTRESS

by Darren Hall

For the unexpanded VIC 20, available early February. Space Fortress is a machine code arcade quality game with brilliant action and clean very attractive graphics, and absolutely amazing sound effects and probably the best game for the VIC 20 from any manufacturer to date. There are 20 skill levels, but you always start at skill level one, first of all you are attacked by 3 waves of the suicide squad, then 3 waves of sidewinders then 3 waves of sistorian swoopers. Finally you are attacked by the purple avengers. All these different deadly defence forces attack you using different methods of attack. After you have destroyed the last wave of purple avengers, the Space Fortress appears, this you have to shoot down before it puts up its defence shields and disappears into hyperspace. If you shoot it down you advance to the next skill level. If you fail, you go back to the skill level that you were on. Each time you destroy the fortress you gain an additional life (you start with 5).

## SUPER NINE

by Ian Morrison and David Anderson

for the unexpanded ZX81

Altogether there are nine machine code games, all on the one tape. CANYON: you have to guide your space ship along a canyon which gets progressively narrower. 50 skill levels and 50 speed levels.

ASTEROIDS. You have to guide your ship across the screen, avoiding the asteroids. 10 skill levels. 50 speed levels.

ASTRO BLASTER. The object of the game is to shoot down the fireballs, asteroids, and enemy craft.

DEFENDER. The object of the game is to shoot down the enemy craft and save the humanoids.

SQUASH. A two player game of squash, both players being able to move simultaneously, the loser being the first one to miss the ball 3 times.

SCRAMBLE. You have to avoid the mountainous landscape, shoot down the rockets and blast the ammunition dumps.

SKETCH. Create your own pictures on your TV screen, with rub out facility, also you can copy your artwork to the ZX printer.

COSMIC RAIDER. You must shoot down the aliens whilst avoiding the clouds and mountains.

FOUR THOUGHT. A two player game, the object of which is to get four counters of your own in a row, horizontally, vertically, or diagonally.

## MARTIAN RAIDER

by Cliff Ramshaw

Our top selling game for the unexpanded VIC 20, Martian Raider is a machine code, arcade quality game. You are the pilot of an intergalactic battle ship, your mission is to bomb the cities, ammunition dumps, and ground to air missiles of the evil Martian overlords. Attacking you are the U.F.O.s, meteorite storms, and the ground to air missiles. All of which (if you are quick enough), you can shoot down. You have a limited time to complete your mission. But this time is extended each time you hit an ammunition dump. If you lose one of your three lives (a bonus life is awarded at 10,000 points) you will get additional time with the new life. There are several different screens which advance automatically during play, superb graphics and action. Uses joystick, or easy to use keyboard controls.



## MOONS OF JUPITER

by Dave Byrden

For the expanded VIC 20. Will run in 3K and/or 8K and/or 16K.

Moons of Jupiter is a machine code arcade quality game with absolutely brilliant actions and graphics, with 3 skill levels. The game is similar in concept to asteroids, but with better action and graphics; you have to shoot the moons which then break up into smaller fragments, which you also have to shoot and yet again they will break up, all the time coming at you from different directions and at different speeds. Watch out for the U.F.O.s, but even more deadly are the Gologs, these you cannot shoot, you have to lure them into the moons to destroy them. You start with 5 lives and gain one additional life each time you clear the screen. Uses joystick or easy to use keyboard controls.

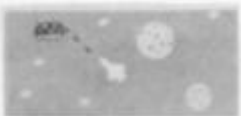

## SHARK ATTACK

by Cliff Ramshaw

For the unexpanded VIC 20. Shark Attack is a machine code, arcade quality game. You have only three lives.

You are in shark infested waters after being thrown overboard from a pirate ship. Your only protection being an atomic net which you trail behind you. Trying to trap the sharks (hopefully all together) and proceed to fill the screen with the net. If you stop, or cover your tracks for too long the sharks will escape and come after you. Each time you fill the screen with your net. The screen will clear, two octopuses will appear, and the sharks will increase their ferocity of attack. Each additional time that you fill the screen, two extra octopuses will appear, and the sharks will grow more ferocious. Uses joystick, or easy keyboard controls.



## SEA INVASION

by Cliff Ramshaw

Sea Invasion is a machine code, arcade quality game, similar in concept to "Space Invaders" but much better in many respects. There are five skill levels; 1, beginner; 2, trainee; 3, semi-professional; 4, professional; 5, ace; so no matter how fast or slow your reflexes are, there is a speed to match your skill. Unlike Space Invaders, the creatures do not move left then right, etc., but move off the right of the screen, and come back from the left, so there is no safe place to hide. Uses joystick, or easy keyboard controls.



## NEWGAMES... AVAILABLE EARLY MARCH...

Vic 20... Power Blaster (unexpanded)... The year is 2201, the Universe has been ravaged by many wars. You are the commander of a Venusian defence force patrol ship, your mission is to blast away the remote control high power bombs which are being planted by the Martian overlord's personal attack force...  
Vic 20... Time Destroyers (expanded)... +3K, or +8K, or +16K... You are the commander of a fleet of destroyers, your mission is to save the Universe from being disintegrated by the Vorteniens, a race of aliens from a distant galaxy, who have found a way of destroying the space/time continuum, without affecting their own galaxy...

## OUR GAMES ARE AVAILABLE FROM ALL GOOD HOME COMPUTER SHOPS, INCLUDING:

Micro C inside Currys at: Birmingham (233 1105), Leeds (46601), Luton (425079), Nottingham (412455), Southampton (29676), Inside Bridgers at: Bristol (650501), New Malden (01-949 2091), and at: Leicester (546224), London (01-387 9275), Manchester (834 0144)... Chromasonic Electronics, 48 Junction Road, Archway, London N19 (01-263 9493/9495), Maplin Electronic Supplies Ltd., P.O. Box 3, Rayleigh, Essex (0702 552911/554155), Gemini Electronics, 50 Newton Street, off Piccadilly, Manchester (236 3083), Gamer, 24 Gloucester Road, Brighton... Dixons, Queensmere, Slough (23211)... Channel One, 174 High Street, Hornchurch, Essex (75613) and Golden Cross Parade, Rochford, Essex (540455), Twill Star Computer, 17 Regina Road, Southall... Data Asstette, 44 Shroton Street, London NW1... Graham & Son, 51 Gortin Road, Omagh, N. Ireland... Ram Electronics, 88 Fleet Road, Fleet, Hants. (5858)... Eccleston Electronics, Legge Lane, Birmingham... The Computer Centre, 14 Hemmels, Laindon, Essex (0268 416155)... Microspot, 15 Moorfields, Liverpool... R. Seedle, 47 Woodlands Road, Ansdell, Lytham St. Annes... Cambridge Computer Centre, 1 Emmanuel street, Cambridge... Karlinda & Co., Elliott Road, Seely Oak, Birmingham... The Sharp Computer Shop, Melville Street, Lincoln... Milequip, 7A Hare Lane, Gloucester (411010)... North West Business Machines, Curate Street, Great Harwood, Lancs... Instep Footwear, 23 King Street, Great Yarmouth... J.A.D., 21 Market Avenue, Plymouth (669462)... Metyclean, 92 Victoria Street, London SW1 (01-828 2511)... Metyclean, 137 The Strand, London WC2 (01-240 2321)... Metyclean, 177 London Road, Croydon (01-686 8626)... All branches of Laskeys, Vic Centre, 154 Victoria Road, Acton W3 (01-992 9904)... A. C. Systems, Exeter... Microtrading, Birmingham... Supersoft, Harrow... Anirog Computers, Horley, Surrey (346083)... Ozwise Computers, Harrow (429 1060)... Cavendish Data Systems, South Norwood (656 8941)... Software Master, 30 Lincoln Road, Birmingham... Tomorrow's World, Dublin... Algray Software, Barnsley (83199)... Computer & Business Systems, Nelson, Lancs. (0282) 601191... Dyad Developments, Oxon. (08446 729)... Leisurronics/Blackpool Computer Stores (0253 27091)... Carlou Radio Ltd., Bedford (60447)... Byte Shop Computerland, Glasgow (221 7409); Nottingham (40576); Manchester (236 4737)... First Byte Computers, Main Centre, Derby (365280)... Simmons Magee Computers Ltd., Twickenham (891 4477)... Capital Computer Systems, Ifford (553 3026)... A.O.M. Business Systems, L.V.E. Building, Leicester (548923)... Jutea Ltd., Bridge, Near Canterbury, Kent (0227 830083)... Twickenham Computer Centre (01-892 7896)... Kent Microcomputers, Maidstone (0622 52784)... J.S. Simnett Computers Ltd., The Computer Shop, Kingston (01-546 3793)... Chris Denning Ltd., Poole (0202 761859)... Yorkshire Micro Computers, Scarborough, Yorks. (0723 78136)... Taylor Wilson Systems, Oakfield House, Station Road, Dorridge.

```

1090ENDPROC
1100DEFPROCghostmove
1110EX=RND(4)
1120U3=U1:V3=V1:U4=U2:V4=V2
1130GN EX GOTO 1140,1150,1160,1170
1140U1=U1-1:GOTO1180
1150U1=U1+1:GOTO1180
1160V1=V1-1:GOTO1180
1170V1=V1+1
1180FZ=RND(4)
1190GNFZ GOTO 1200,1210,1220,1230
1200U2=U2-1:GOTO1250
1210U2=U2+1:GOTO1250
1220V2=V2-1:GOTO1250
1230V2=V2+1
1240IF?(HIMEM+U2+V2*40)=251 OR ?(HIMEM+U2+V2*40)=247THEN PROCdead
1250IF?(HIMEM+U2+V2*40)=160 THEN GOTO1270
1260IF?(HIMEM+U2+V2*40)=164 THEN GSC=GSC+1 ELSE U2=U4:V2=V4:GOTO1280
1270PRINTTAB(U4,V4);CHR$(160)
1280IF?(HIMEM+U1+V1*40)=160 THEN GOTO1310
1290IF?(HIMEM+U1+V1*40)=251 OR ?(HIMEM+U1+V1*40)=247THEN PROCdead
1300IF?(HIMEM+U1+V1*40)=164 THEN GSC=GSC+1 ELSE U1=U3:V1=V3:GOTO1320
1310PRINTTAB(U3,V3);CHR$(160)
1320PRINTTAB(U1,V1);CHR$(223);TAB(U2,V2);CHR$(192)
1330ENDPROC
1340DEFPROCdead
1350SOUND 0,-15,5,10
1360PROCend
1370PRINTTAB(7,22);CHR$(141);CHR$(129);"YOU'VE BEEN EATEN!:"
1380PRINTTAB(7,23);CHR$(141);CHR$(129);"YOU'VE BEEN EATEN!:"
1390PRINTTAB(X1,Y1);" ";TAB(X2,Y2);" "
1400PRINTTAB(0,1);CHR$(141);"ANOTHER GAME?"
1410PRINTTAB(0,2);CHR$(141);"ANOTHER GAME?"
1420B$=GET$
1430IFB$="Y" THEN 1460
1440IFB$("<"N" THEN 1420
1450GOTO 1540
1460PRINTTAB(17,1);CHR$(141);CHR$(130);" SKILL LEVEL?"
1470PRINTTAB(17,2);CHR$(141);CHR$(130);" SKILL LEVEL?"
1480A$=GET$
1490A=VAL(A$)
1500IF A<1 OR A>2 THEN 1480
1510SKILL=A
1520CLS
1530GOTO 80
1540CLS
1550FX12,0
1560END
1570ENDPROC
1580DEFPROCintro
1590 PRINTTAB(15,5);CHR$(141);CHR$(131);"PACMAN"
1600 PRINTTAB(15,6);CHR$(141);CHR$(131);"PACMAN"
1610PRINTTAB(10,10);CHR$(130);"CONTRDLS"
1620PRINTTAB(10,12);"W" - UP";TAB(10,13);"X" - DOWN";TAB(10);
"A" - LEFT";TAB(10);"D" - RIGHT"
1630PRINTTAB(12,18);CHR$(129);"SKILL LEVEL(1 OR 2)?"
1640A$=GET$
1650A=VAL(A$)
1660IF A<1 OR A>2 THEN 1640
1670SKILL=A
1680PRINTTAB(10,23);CHR$(131);"HIT ANY KEY TO CONTINUE"
1690A$=GET$
1700ENDPROC

```

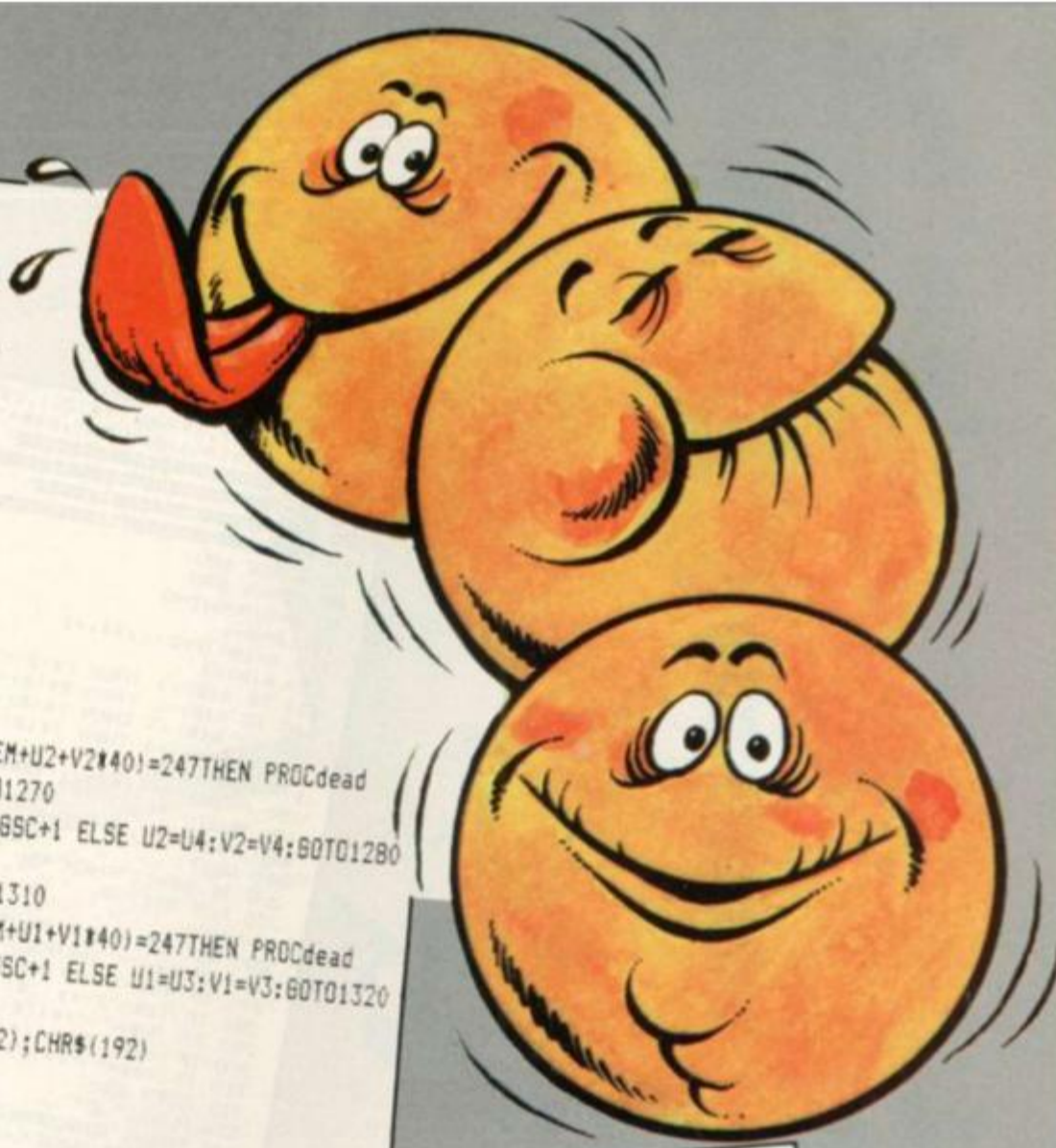

- VARIABLES FOR PACMAN
- A - VALUE OF A\$ FOR SKILL INPUT
  - A\$- UTILITY VAR. FOR KEYBOARD INPUT
  - AZ- 1ST DATA LINE NO.
  - BZ- LAST DATA LINE NO.
  - CZ- STEP SIZE FOR DATA
  - DZ- MAZE COLOUR
  - EX- RANDOM VAR. FOR 1ST GHOST MOVE
  - FZ- RANDOM VAR. FOR 2ND GHOST MOVE
  - IZ- COUNT VAR. FOR DATA
  - JZ- COUNT VAR. TO READ DATA INTO 'K'
  - K - ARRAY FOR STORE OF DATA
  - MX- VAR. FOR MAZE SET-UP
  - NZ- VPOS FOR MAZE SET-UP
  - PZ- VAR. FOR PACMAN CHAR. NO.
  - SZ- HORIZONTAL VAR. FOR DOTS
  - SC- YOUR SCORE
  - GSC-NO. OF DOTS EATEN BY GHOSTS
  - HSC-HIGH SCORE
  - SHEET-PRESENT SHEET NO.
  - SKILL-SKILL LEVEL
  - TZ- VERTICAL VAR. FOR DOTS
  - U1- HORIZONTAL POS. OF 1ST GHOST
  - U2- HORIZONTAL POS. OF 2ND GHOST
  - U3- STORE OF OLD U1 FOR SCREEN CHECK
  - U4- STORE OF OLD U2 FOR SCREEN CHECK
  - V1- VERTICAL POS. OF 1ST GHOST
  - V2- VERTICAL POS. OF 2ND GHOST
  - V3- STORE OF OLD V1 FOR SCREEN CHECK
  - V4- STORE OF OLD V2 FOR SCREEN CHECK
  - XZ- HORIZONTAL POS. OF PACMAN
  - X1- STORE OF OLD XZ FOR SCREEN CHECK
  - YZ- VERTICAL POS. OF PACMAN
  - Y1- STORE OF OLD YZ FOR SCREEN CHECK

# SIMON

RUNS ON A SHARP MZ-80K IN 4K

```

10 DIM A(20),Z$(20),X$(20),U$(20),U1$(20)
20 J=0:K=0:L=0:AA$="":BB$="":CC$="":DD$="":EE$="":FF$="":GG$="":HH$="":II$="":JJ$="":KK$="":LL$="":MM$="":NN$="":OO$="":PP$="":QQ$="":RR$="":SS$="":TT$="":UU$="":VV$="":WW$="":XX$="":YY$="":ZZ$="":
30 U$="#####"
40 I$="#####"
50 O$="#####"
60 P$="#####"
70 GOSUB 680
80 GOSUB 830
90 B=0:N=0:M=0
100 B=B+1
110 X=INT(RND(1)*4)+1
120 A(B)=X
130 IF A(B)=1 THEN Z$(B)="A":X$(B)=U$
140 IF A(B)=2 THEN Z$(B)="_A":X$(B)=I$
150 IF A(B)=3 THEN Z$(B)="B":X$(B)=O$
160 IF A(B)=4 THEN Z$(B)="_B":X$(B)=P$
170 FOR I=1TOB
180 PRINT"0":X$(I):"#####"
190 MUSIC Z$(I)
200 PRINT"0":X$(I):" 0000 "
210 NEXTI
220 IF A$="Z" THEN 450
230 FOR I=1TOB
240 M=0
250 GET V$:M=M+1:IF M=100 THEN 330
260 IF V$="" THEN 250
270 IF (V$="P")*(Z$(I)="A") THEN 550
280 IF (V$="F")*(Z$(I)="_A") THEN 550
290 IF (V$="-")*(Z$(I)="B") THEN 550
300 IF (V$="_")*(Z$(I)="_B") THEN 550
310 IF (V$="Y")+(V$="P")+(V$="-")+(V$="_") THEN 330
320 GOTO 250
330 MUSIC"_"
340 PRINT"INCORRECT"
350 IF B>J THEN L=K:K=J:J=B-1:CC$=BB$:BB$=AA$:AA$=PP$:GOSUB 560:GOTO 380
360 IF B>K THEN L=K:K=B-1:CC$=BB$:BB$=PP$:GOTO 380
370 IF B>L THEN L=B-1:CC$=PP$
380 PRINT"000":TAB(20):"Top three scores:"
390 PRINT"00":TAB(30):"1":J:TAB(35):AA$
400 PRINT TAB(30):"2":K:TAB(35):BB$
410 PRINT TAB(30):"3":L:TAB(35):CC$
420 PRINT"#####Do you want a replay of last run? (PRESS Z)"
430 PRINT"Do you want a replay of longest run? (PRESS X)"
440 PRINT"#####ANOTHER GAME?#####"
450 GET A$:IF A$="" THEN 450
460 IF A$="Z" THEN 170
470 IF A$="X" THEN 610
480 IF A$="N" THEN 670
490 IF A$="Y" THEN 800
500 GOTO 450

```

Meet our not so simple Simon. He'll challenge you to crack his mind boggling code which consists of a series of musical notes and lights. All you have to do is keep up with him!

This game is based on the electronic toy of the same name. The aim is to repeat a sequence of randomly produced notes and lights correctly. Each time you complete a round the computer adds an extra note/light to the

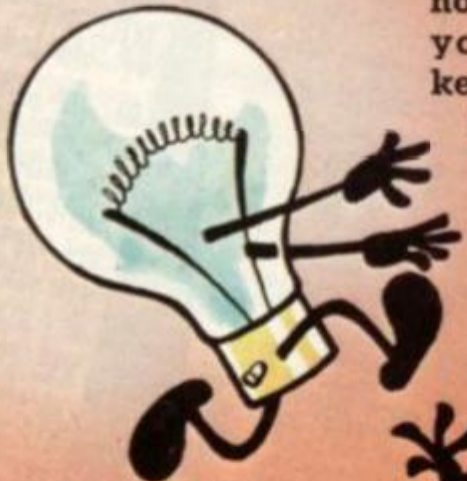

Illustration: Terry Rogers

BY J. D. WILLEY

```
510 NEXT I
520 N=N+1
530 FOR I=1 TO 50:PRINT "CORRECT MOVE No.":N:
NEXT I:PRINT "0"
540 GOTO 100
550 PRINT "0";X$(I);"#####";MUSICZ$(I);PRINT "0";X$(I);
"##### ";GOTO 510
560 U=B
570 FOR I=1 TO U
580 U$(I)=X$(I):U1$(I)=Z$(I)
590 NEXT I
600 RETURN
610 FOR I=1 TO U
620 PRINT "0";U$(I);"#####";
630 MUSIC U1$(I)
640 PRINT "0";U$(I);"##### "
650 NEXT I
660 GOTO 450
670 PRINT "0":END
680 PRINT "0";TAB(30);"SIMON"
```

```
690 PRINT "##### The aim of 'SIMON' is to repeat a sequence of ";
700 PRINT "randomly produced notes and lights correctly.";
710 PRINT "Each time you complete a round, the computer will put one more";
720 PRINT "note onto the sequence, until it is impossible to beat."
730 PRINT "##### Use the four blue keys marked:"
740 PRINT "##### (b, -, P, .); As shown: - . . b. ."
750 PRINT TAB(30);". . . . ."
760 PRINT TAB(30);"- . . . ."
770 PRINT TAB(30);". . . . ."
780 PRINT TAB(30);". . . . ."
790 PRINT "##### PRESS ANY KEY"
800 GET A$:IF A$="" THEN 800
810 USR(62)
820 RETURN
830 INPUT "Please can I have your initials? ";P$:USR(62)
840 PRINT "##### PRESS ANY KEY TO START"
850 GET A$:IF A$="" THEN 850
860 PRINT "0";TAB(30);"SIMON";"#####";
870 PRINT "#####";
880 PRINT "#####";
890 PRINT "#####";
900 PRINT "#####";
910 PRINT "#####";
920 PRINT "#####";
930 PRINT "#####";
940 PRINT "#####";
950 PRINT "#####";
960 PRINT "#####";
970 PRINT "#####";
980 FOR I=1 TO 1000:NEXT I
990 RETURN
1000 REM "SIMON" PRODUCED BY J.D.WILLEY NORWICH 1982;FOR THE MZ-80K.
```

sequence — until it is impossible to beat!

The four lights are controlled by four of the Sharp's blue graphics keys. You cannot afford to think about your move for too long as there is a time limit.

At the end of the game the top three highest scores are given, complete with the players' initials, and you are given the option of a replay of the last run, a replay of the longest run, or another game.

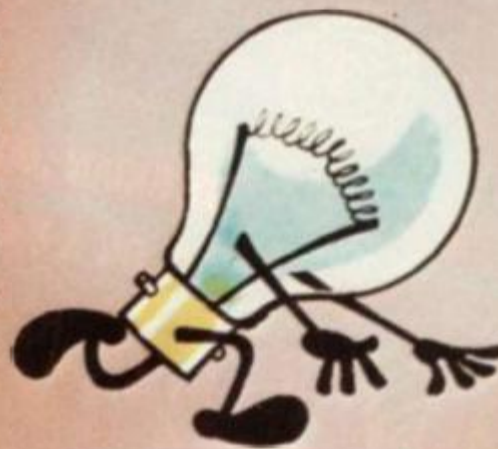



BY BRIAN JAIKENS

RUNS ON A VIC-20 IN 3.5K

# LOGGER

Squaaaaaarrrrkk! There goes that pesky bird, flying off with my axe agin! Ah tell you, I ain't goin' to stand for it much longer. That feathered varmit keeps on swoopin' down on me and stealing my axe.

How can a lumberjack work without his axe? He can't that's the answer! But don't worry I'll get even with that bird if it's the last thing I do . . .

You take the part of this pestered lumberjack and help get his axe back from the feathered fiend. To do this you have to guide your man through a maze of logs and ladders. You climb up the ladders and leap over the logs on your way to catch the bird. The game is similar to that arcade game with the crazy gorilla — as you've probably guessed.

Control keys are: 'D' to climb; 'Z' and 'C' left and right; space bar to jump.

The game is split into two parts. The first lists the instructions and makes the characters. The second is the game and needs the 3K expander.

Brian the author reckons that the game has enough memory to enable Vic owners with moderate programming skills to work out their own screens of platforms and ladders once they get bored with the existing one. So pick up your axe and head for the trees and keeping an eye out for that pesky bird.



```

5 POKE51,0:POKE52,28:POKE55,0:POKE56,28:POKE36869,255:POKE36879,25
10 PRINT "VIC          LOGGER"
11 PRINT "          BY BRIAN JAIKENS"
12 PRINT "YOU ARE A LUMBERJACK WHO HAS JUST HAD HIS AXE STOLEN BY A BIRD"
13 PRINT ">* YOU MUST GET TOM +, THE BIRD BY USING -, LADDERS AND"
14 PRINT "JUMPING LOGS"
15 PRINT "ON YOUR WAY YOU CAN GET BONUS POINTS AND AN EXTRA MAN EVERY"
16 PRINT "8000 POINTS"
17 PRINT "THE CONTROLS ARE"
18 PRINT "D CLIMB"
19 PRINT "Z C LEFT RIGHT"
20 PRINT "SPACE BAR TO JUMP"
21 PRINT "BY SHAILSOFT"
65 FOR I=7168 TO 7679:READ C:POKE I,C:NEXT
70 DATA 60,66,153,165,165,153,66,60
71 DATA 60,102,102,126,102,102,102,0
72 DATA 124,102,102,124,102,102,124,0
73 DATA 60,102,96,96,96,102,60,0
74 DATA 124,102,102,102,102,102,124,0
75 DATA 124,96,96,120,96,96,124,0
76 DATA 124,96,96,120,96,96,96,0
77 DATA 60,102,96,110,102,102,60,0
78 DATA 102,102,102,126,102,102,102,0
79 DATA 24,24,24,24,24,24,24,0
80 DATA 12,12,12,12,12,100,56,0
81 DATA 102,100,120,112,120,100,102,0
82 DATA 96,96,96,96,96,96,124,0
83 DATA 66,102,126,126,102,102,102,0
84 DATA 70,102,118,126,110,102,102,0
85 DATA 60,102,102,102,102,102,60,0
86 DATA 124,102,102,124,96,96,96,0
87 DATA 60,102,102,102,110,102,62,1
88 DATA 124,102,102,124,120,100,102,0
89 DATA 60,102,96,60,6,102,60,0
90 DATA 126,24,24,24,24,24,24,0
91 DATA 102,102,102,102,102,102,60,0
92 DATA 102,102,102,60,60,24,24,0
93 DATA 102,102,102,126,126,102,66,0
94 DATA 102,102,60,24,60,102,102,0
95 DATA 102,102,102,60,24,24,24,0
96 DATA 126,6,12,24,40,96,126,0
97 DATA 56,124,127,244,236,194,68,56
98 DATA 122,127,126,56,56,48,48,56
99 DATA 28,62,254,47,55,67,34,28
100 DATA 94,254,126,28,12,12,12,28
101 DATA 126,66,126,66,126,66,126,66
102 DATA 0,0,0,0,0,0,0,0
103 DATA 28,62,62,127,127,62,28
105 DATA 62,127,127,127,54,54,118,7
106 DATA 62,127,127,127,54,54,55,112
107 DATA 50,254,254,50,48,48,48,48
108 DATA 38,52,8,62,125,125,123,62
109 DATA 48,56,36,38,111,253,214,96
110 DATA 135,133,165,165,245,37,39,0
111 DATA 103,149,149,101,149,149,103,0
112 DATA 7,9,29,31,27,12,100,254
113 DATA 192,32,112,240,176,96,76,254
114 DATA 255,248,242,240,225,104,98,96
115 DATA 254,62,30,94,14,44,12,76
116 DATA 100,48,26,15,4,4,28,62
117 DATA 44,152,48,224,64,64,112,248
118 DATA 255,194,127,194,255,66,126,66
119 DATA 60,102,110,126,118,102,60,0
120 DATA 8,24,56,24,24,24,60,0
121 DATA 60,102,6,60,96,96,126,0
122 DATA 60,102,6,28,6,102,60,0
123 DATA 12,28,60,108,126,12,12,0
124 DATA 126,96,124,6,6,102,60,0
125 DATA 60,102,96,124,102,102,60,0
126 DATA 126,102,12,24,24,24,24,0
127 DATA 60,102,102,60,102,102,60,0
128 DATA 60,102,102,62,6,102,60,0
129 DATA 255,170,85,170,255,0,0,0
130 DATA 96,255,255,7,3,0,0,0
131 DATA 3,4,9,10,10,9,4,3
132 DATA 192,32,144,80,80,144,32,192
133 DATA 0,0,0,7,143,255,255,199
134 DATA 4,20,62,239,231,223,254,50
140 PRINT "PRESS A KEY"
145 GET A$:IFA$="" THEN 145
150 PRINT "XXXXXXXXX NOW LOAD VIC LOGGER"
152 PRINT "HOLD DOWN THE SHIFT KEY AND TAP THE RUN STOP KEY NOW"

```

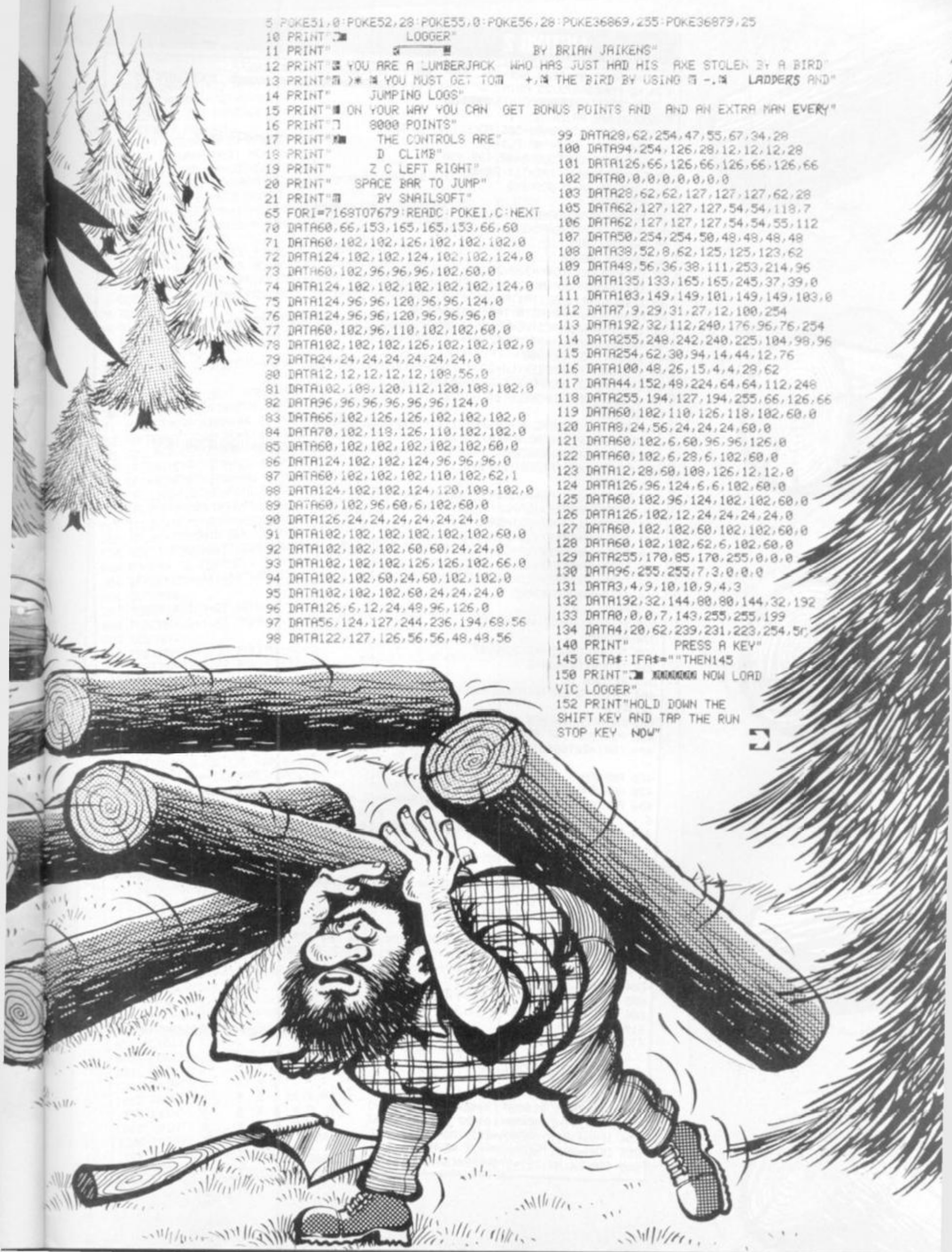



```

658 IFK=32THENGOSUB700
660 GOSUB60
662 IFH=29ANDPEEK(MN-21)=31THENPOKEMN+1,31:POKEMN+23,31
664 IFH=27ANDPEEK(MN-23)=31THENPOKEMN-1,31:POKEMN+21,31
667 IFPEEK(MN+44)=59THENGOSUB100
668 IFPEEK(MN+44)=32THEN000
669 POKE36877,203:POKE36877,0
675 POKE198,0:RETURN
700 IFH=29THENMN=MN-23:MC=MC-23
701 IFH=27THENMN=MN-21:MC=MC-21
702 GOSUB60:IFMN+44=L0THEN00SUB730
703 IFPEEK(MN+66)=59THENPOKEMN+66,32:POKEMC+66,2:GOSUB730
704 IFPEEK(MN-22)=47THENJM=1
705 IFH=29ANDPEEK(MN+1)=31THENPOKEMN+23,31:POKEMN+45,31:GOSUB300:GOSUB70:GOTO709
706 IFH=27ANDPEEK(MN-1)=31THENPOKEMN+21,31:POKEMN+43,31:GOSUB300:GOSUB70:GOTO710
708 GOSUB300:GOSUB70
709 IFH=29THENMN=MN+21:MC=MC+21:IFJM=1THENPOKEMN-21,31:POKEMN+1,31:JM=0
710 IFH=27THENMN=MN+23:MC=MC+23:IFJM=1THENPOKEMN-23,31:POKEMN-1,31:JM=0
713 IFPEEK(MN+22)=37ORPEEK(MN+22)=30THENGOSUB740
719 GOSUB60:IFMN=0097ORMN=0096THENGOSUB70:MN=MN+22:MC=MC+22
720 RETURN
730 SC=SC+40:POKEMN+00,39:POKEMC+00,0:FORS=140T0200:POKE36874,S:NEXT:POKE36874,0
731 POKEMN+00,32:IFPEEK(MN+66)=47THENPOKEMN+00,31:POKEMC+00,2
733 RETURN
740 POKEMN+66,40:POKEMC+66,0:SC=SC+00:POKE36874,225:FORD=1T0100:NEXT:POKE36874,2
35
741 FORD=1T0100:NEXT:POKE36874,0:POKEMN+66,32:POKEMC+66,2:RETURN
750 H=33:B=34:FORI=1T04:MN=MN-22:MC=MC-22
751 IFI=1THENPOKEMN+44,31:POKEMC+44,2
752 POKE36877,220:POKE36877,215:POKE36877,0
753 GOSUB60:GOSUB300:POKEMN+22,35
754 IFI<4THENPOKEMN+22,31:POKEMC+22,2
755 IFI=4THENPOKEMN+44,47:POKEMC+44,2
756 IFLG>MN+35THENPOKEL0,32:LG=7775:DR=2
757 IFLG>MN+35ANDPEEK(LG-22)=31THENPOKEL0,31:LG=7775:DR=2
767 IFLG<=7775THENPOKEL0,32:LG=7775:DR=2
768 IFLG<=7775ANDPEEK(LG-22)=31THENPOKEL0,31:LG=7775:DR=2
770 NEXTI:POKE36877,220:POKE36877,215:POKE36877,0:RETURN
800 POKEMN,32:POKEMC,2:MN=MN+22:MC=MC+22
804 IFPEEK(MN+44)=58THEN007
806 GOTO000
807 GOSUB70:IFH=27THEN013
808 POKEMN+22+1,63:POKEMC+22+1,0:POKEMN+22,62:POKEMC+22,0:POKEMN,32
809 GOSUB021
810 POKEMN+22+1,32:POKEMC+22+1,2:POKEMN+22,32:POKEMC+22,2:POKEMC,2:GOTO019
813 POKEMN+22-1,62:POKEMC+22-1,0:POKEMN+22,63:POKEMC+22,0:POKEMN,32
814 GOSUB021
815 POKEMN+22-1,32:POKEMC+22-1,2:POKEMN+22,32:POKEMC+22,2:POKEMC,2
819 NM=NM-1:GOSUB605:IFNM=0THEN3
820 POKEL0,32:H=29:B=30:POKEL0+30720,2:POKE198,0:GOTO14
821 DATA195,000,0,00,195,600,0,00,195,200,195,000,0,00,203,500,201,200,0,00,201,
600,195
824 DATA200,0,00,195,600,0,00,195,200,0,00,195,1000,-1
825 READP:IFP=-1THENRESTORE:FORD=1T01500:NEXT:RETURN
826 READD:POKE36875,P:FORN=1T0D:NEXT:POKE36875,0:FORN=1T020:NEXT:GOTO025
900 FORI=4T01STEP-1
903 IFI>2THENPRINTLEFT$(P0$,I)TAB(4)BR$
905 IFI=2THENPRINTLEFT$(P0$,I)TAB(4)LEFT$(BR$,0)
906 IFI=1THENPRINTLEFT$(P0$,I)TAB(4)LEFT$(BR$,3)
907 IFI<5THENPRINTLEFT$(P0$,I+1)TAB(4)" "
908 FORD=1T0500:NEXTD,I
910 PRINT" "TAB(4)" " :FORD=1T01000:NEXT
915 IFPB<=0THEN940
917 FORL=1T08:PRINT" "TAB(15)" " :FORD=1T0200:NEXT
918 PRINT" "TAB(15)"BONUS":FORM=100T0235STEP2:POKE36876,M:POKE36876,0:NEXTM,L
921 FORJ=1TOPBSTEP10:SC=SC+10:PB=PB-10:POKE36875,235
922 PRINTSC#9C:PRINT" "TAB(15)BP#PB" " ;
923 IFSC=>3MANDNM<5THENNM=NM+1:BM=BM+0000:GOSUB605:GOSUB612
924 POKE36875,0:NEXTJ
940 BP=BP+500:FORD=1T01500:NEXT:GOSUB70:POKEL0,32
941 IFBP=4000THENBP=1000
942 PF=PF+1:IFPF>2THENPF=1
950 GOTO14
1000 POKE198,0:PRINTCHR$(0)" "00 00 00"
1001 PRINT" @ @ @ @ @ @ @ " 1009 PRINTTAB(6)"@ @ @ "
1002 PRINT" @ @ @ @ @ " 1010 PRINT" @ @ @ @ @ @ @ @ @ "
1003 PRINT" @ @ @ @ @ @ @ @ " 1011 PRINTTAB(6)"@ @ @ "
1004 PRINT" @ @ @ @ @ @ @ " 1012 PRINTTAB(6)"@ @ @ "
1005 PRINT" @ @ @ @ @ @ @ " 1013 PRINTTAB(6)"@ @ @ @ @ @ "
1006 PRINT" @ @ @ @ @ @ @ @ " 1014 PRINTTAB(5)"PRESS A KEY":POKE198,0
1007 PRINTTAB(6)"@ @ @ @ @ @ @ " 1015 GETA$:IFA#=""THEN1015
1008 PRINTTAB(6)"@ @ @ " 1040 POKE36879,191:RETURN

```

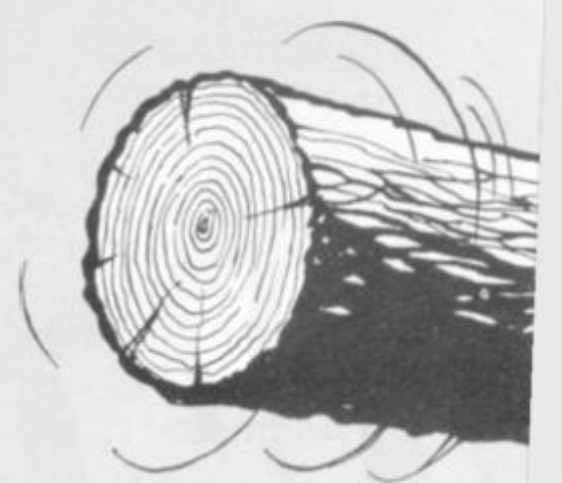
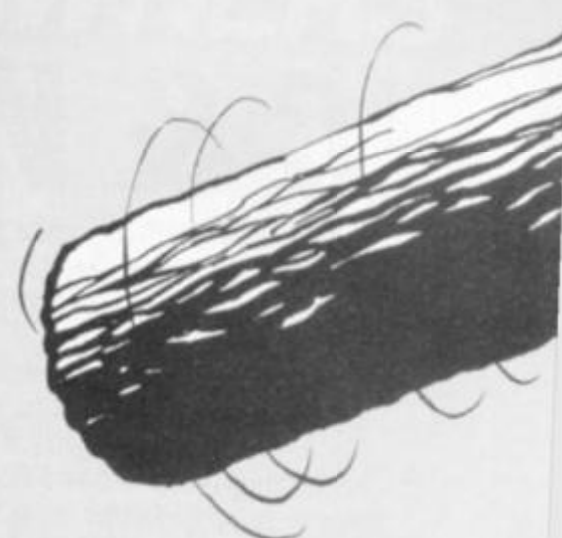

# C & VG SOFTWARE FORM

Have you written a games program which you feel is just right for C&VG? If so we have come up with a form to ensure that we can test it out and give you our views on it, as quickly as possible.

We would prefer a tape and listing but can work from just a tape and will return it to you if it doesn't find its way into the magazine. We will also need an additional sheet explaining the game and its theme. And any documentation like lists of variables or how certain routines are working, would be of great help to beginners.

This form will merely help us to keep a check on your game as it goes through our testing process and make sure we have all the information we need to present it properly in the magazine.

If you don't want to cut up the magazine, we will accept photocopies or close copies of this page. This form will be appearing regularly in C&VG issues from now on.

Remember we pay £10 for each listing published and you could win our Programmer of the Year Contest where we will try to turn the winner into a best-selling games author.

Program name: .....

Machine make: ..... Model .....

Other models it should run on: ..... Number of K needed to run it: .....

Other equipment (joysticks, Extended Basic, add ons, etc.) needed to run it: .....

Author's Christian name: ..... Sur-name: .....

Address: .....

Tel: ..... Date: .....

Type of game: (If original please say so) .....

Loading instructions: .....

Game instructions: (If not included in the listing) .....

Office use only	
Date received: .....	Evaluator's comments
Acknowledgement sent: <input type="checkbox"/>	Good enough to publish <input type="checkbox"/>
Name of evaluator: .....	Needs some tidying up <input type="checkbox"/>
Date sent out: .....	Not worth publishing <input type="checkbox"/>
Date due back: .....	Same game already published on this micro <input type="checkbox"/>
Needs to be returned to author for alterations: <input type="checkbox"/>	Wouldn't load <input type="checkbox"/>
Date sent: .....	
Due to be published in issue of magazine: .....	

# DRAGON OWNERS

## BARRELS OF FUN IN THE NEW

ANOTHER GREAT GAME FROM MICRODEAL - GUARANTEED TO KEEP YOU PLAYING FOR HOURS TRYING TO SAVE THE BEAUTY FROM THE BEAST. ROLLING BARRELS! KILLER FLAMES! LADDERS AND RAMPS TO NEGOTIATE IN THE BEST GAME EVER FOR THE DRAGON 32 HOME COMPUTER.



# DONKEY KING

FROM TOM MIX



All Cassettes £8 each (including VAT & Postage)

AVAILABLE FROM DRAGON 32 DEALERS NATIONWIDE OR ORDER DIRECT FROM:

# MICRODEAL

41 TRURO ROAD, ST. AUSTELL, CORNWALL PL25 5JE TEL 0726-67676

Send 1st Class Stamp for FREE Software Lists for Dragon and Tandy range of Computers.

AVAILABLE FROM SELECTED  
**Boots** & **John Menzies**  
STORES





# WITH EMPIRE

## BATTLE REPORTS

Some 63 star systems were disrupted by the clamour of battle in turn No. 2 with the defenders holding out each time.

Once again the closest battle came at Olex which barely held onto Sun citizenship against a vast Pirate army from the neighbouring three systems.

The conflict inflicted heavy losses on the defenders who all took a -4 knock to their fleet's total. But in the light of this latest conflict, the two empires have declared a peace treaty for turn three.

The following system defenders suffered losses as a result of their valiant defences: **Hazan**, bonus -4; **Rurus**, bonus -3; **Olex**, bonus -5; **Sidal**, bonus -2; **Hakub**, bonus -4; **Apel**, bonus -4; **Rolek**, bonus -4; **Opod**, bonus -1; **Tubox**, bonus -3.

Three systems' defenders managed to salvage a profit from defeating wealthy attacking ships: **Xokeg**, bonus 2; **Meden**, bonus 3; **Otan**, bonus 2.

A few changes to the Diplomatic Diagram this turn. As already noted, a peace treaty has been negotiated between the Pirates and the Sun Empire. The Amethyst Empire has also declared peace with D'Taan's Empire.

The D'Taan's Empire has declared war on the Water Empire and the Pirate Empire. The Diplomatic Diagram below shows the changes. When a line connects two empires they are at war during turn three.

Looking ahead for likely trouble spots this turn, D'Taan's Empire's new foes may give it's Cazur system problems.

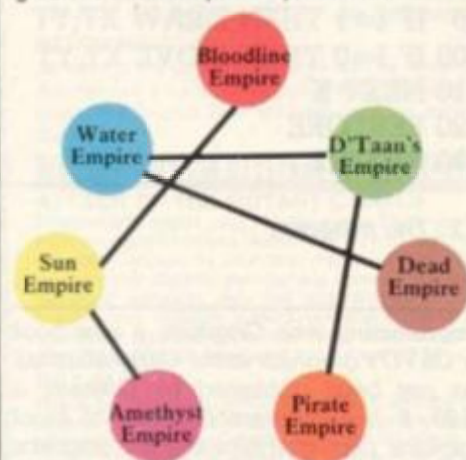

The Diplomatic Diagram

FOZUZ ○	LARUB ◆	YIBET ◆	XOLIP ♥	ITIL ♥	FUNUS ♥	LULIP ◆	YANOK ♥	XOKEG ◆	ISOX ○	
295 11 190 731 207 54 187 533 154 133 173 600 203 37 200 263 210 150 754 87	VIZAX ○	QIRUS ♥	HAZAN ◆	ABOB ○	SONER *	VEPOZ ♥	QATOT ○	HEZOD *	ASOL *	SUXEK ♥
210 69 270 348 181 168 153 214 414 94 195 190 186 204 423 96 259 34 259 352	BAROV *	WIDAN *	RURUS ○	MUPIP *	NAXIG ○	BETID ◆	WAVAB ○	RIVEV *	MEGUD ○	NABOK ○
333 75 287 102 244 29 532 47 227 29 162 253 161 115 365 47 228 211 217 37	DALIX ♥	OLEX ♥	TASAT ♥	CAZUV *	GOVAX ♥	DITUG ◆	OKAP ♥	TOXAZ ◆	CIXAN ◆	GOTEG ♥
144 200 236 400 201 335 329 108 220 300 211 290 255 363 278 15 197 111 156 331	ERAK *	KOVEP ◆	USUG *	PEBOB ♥	JADEG ◆	ENAK ○	KEPAR ♥	UGON ◆	POROV ◆	JINIS *
299 44 184 148 395 71 183 323 200 146 212 66 205 248 237 216 156 295 367 40	FADIS *	LOKIK ♥	YUSES *	XAPUS ○	IXIP *	FAGIL ♥	LIZAG *	YODAZ ◆	XUGOD *	IBED ♥
407 6 254 238 299 95 246 26 502 91 215 232 274 60 183 90 63 63 192 381	VASUX *	QUXIN ○	HIPEB ◆	ASOR ○	SIDAL ♥	VIZET ◆	QAVUV *	HAKUB ○	APEL ◆	SABAG ♥
289 65 175 71 204 296 194 155 217 265 195 73 366 41 164 132 330 24 171 266	BUREP ♥	WAGAP ♥	ROLEK ♥	MINEP ○	NUVEX ♥	BAZIX ○	WUPIV ♥	RORUL ♥	MEDEN ◆	NUZET *
168 452 195 253 252 171 185 43 195 328 172 183 154 486 203 595 174 98 299 75	DUSUP *	OPOD *	TUBOX *	CIGER ○	GAZOR *	DABAG ♥	OTAN ◆	TUXUX ○	CESER ♥	GIRIX ◆
259 38 272 81 333 67 132 58 541 77 212 304 183 194 221 60 272 262 213 47	ELAR ○	KERUP ◆	ULEB ♥	PIRAD ♥	JAXEL ○	EDIB ◆	KOLOL *	UKOP ○	PULUD *	JUVAK ◆
134 43 172 20 171 411 191 324 160 251 183 44 305 58 130 300 327 68 155 320										

The Galactic Map

Orders in Block Caps please

Name: .....

Code No: ..... Telephone No: .....

	AT	1st Movement phase		2nd Movement phase	
		ACTION	STAR	ACTION	STAR
FLEET 1					
FLEET 2					
FLEET 3					
FLEET 4					
FLEET 5					
FLEET 6					
FLEET 7					

I wish to move the ..... Empire's Imperial Ship from ..... to .....

Please notify us separately of any change of address.

# GRAPHICS

By Garry Marshall

## ESSENTIALS OF VIDEO GAMES

To be able to reproduce the movements of three-dimensional objects in a realistic fashion is essential to the success of many video games.

There are two essential parts to any program for doing this. They are, first, the production of a perspective view of the object and, second, the application of the rules for movement.

A solid object with straight edges can be described by giving points on its surface and the ways in which they are to be joined to form the edges of the object.

Once an object is described in this way, a perspective view of it can be drawn by applying the perspective transformation to each point that is used in the description and then joining the transformed points

The current position can be given in terms of the initial position by any set of equations with this form as long as when  $T=0$  the equations become:

$$XC = X$$

$$YC = Y$$

$$ZC = Z$$

The form of a program for producing movement of three-dimensional objects can now be given. If the object itself is described by a number of groups of four items of data,  $X, Y, Z$  and  $I$ , in which  $X, Y$  and  $Z$  give the co-ordinates of a point and  $I$  indicates whether the point is joined to the previous one by an edge.

The indicator,  $I$ , takes the value 1 if there is an edge and is 0 if there is not. The form of the program is:

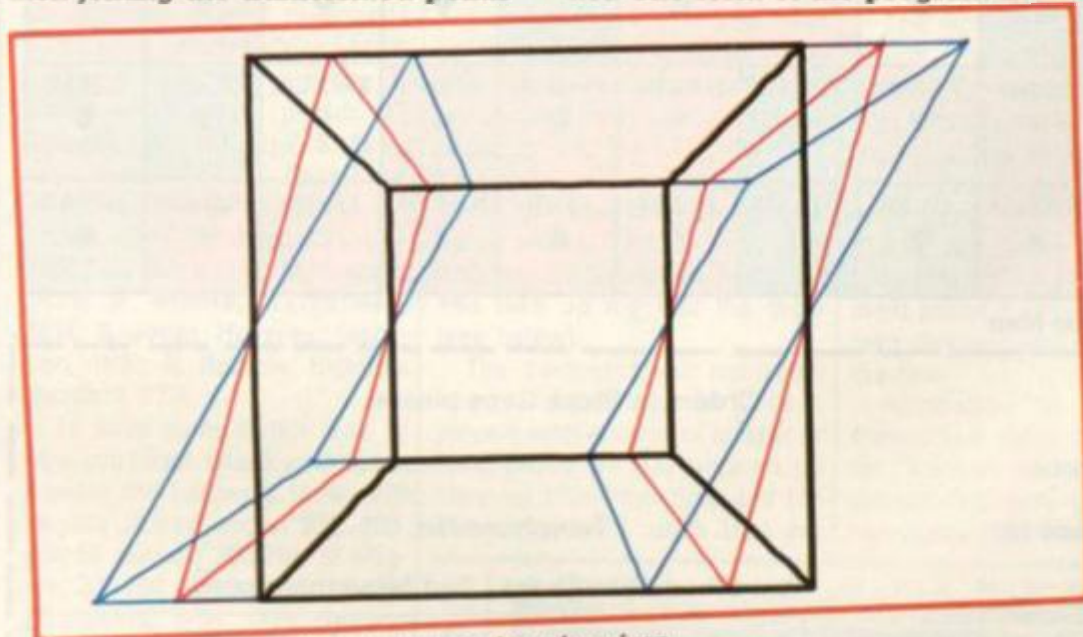

Fig 1: Here a cube is distorted using the rules given.

in the same way as the actual points are joined.

The rules for the movement of the points on the object can be expressed by giving the position of the point at any time,  $T$ , in terms of its initial position at  $T=0$ .

If the co-ordinates of the initial position are denoted by  $(X, Y, Z)$  and those of the current position by  $(XC, YC, ZC)$  then the rules for movement can be written, for example, as:

$$XC = X + T \cdot Y$$

$$YC = Y$$

$$ZC = Z$$

For each group of data items:

Read  $X, Y, Z$  and  $I$

Apply movement rules to give  $XC, YC, ZC$

Find transformed point corresponding to  $(XC, YC, ZC)$

If  $I=1$  then draw a line to this point

If  $I=0$  then move to this point

A program based on this scheme which deals with an object described by  $N$  groups of data which is viewed from a distance  $D$  is shown in Fig 2.

The results that can be produced with this program when  $N$  and  $D$  are initialised and data are added are illustrated in Fig 1.

Once three-dimensional shapes can be created and put into movement, the ways in which they can be used in video games are almost endless.

Imagine a three-dimensional Pacman gobbling up everything around him. In a video game, this is nothing more than a shape that is showing a simple pattern of movements.

In the same way, three-dimensional Space Invaders can be created that can distort themselves so as to avoid missiles fired at them in ways other than moving bodily in one direction or another.

There is no reason why the shapes that are created should be confined to artificial ones such as those of a Pacman or a Space Invader.

Given the high resolutions that are available with most microcomputers, there is no reason why realistic three-dimensional human figures, for example, should not be created and made to move.

These could be superior to the figures that are seen in basketball and football video games at present.

A good deal of data is needed for the creation of such an image. However, once the data is assembled and stored the bulk of the work is done.

The data can be placed in data statements, but it is much simpler to share it between other programs if it is stored in a file.

When it is stored in this way many number of programs can be created and manipulate the shapes thus spreading the work needed initially to create the file.

```
10 FOR T=0 TO 2
20 FOR K=1 TO N
30 READ X,Y,Z,I
40 XC=X + T*Y
50 YC=Y
60 ZC=Z
70 XT=XC/(1 + ZC/D)
80 YT=YC/(1 + ZC/D)
90 IF I=1 THEN DRAW XT,YT
100 IF I=0 THEN MOVE XT,YT
110 NEXT K
120 RESTORE
130 NEXT T
```

Fig 2: The program

*Programming with Graphics, a new book by C&VG's graphics writer Garry Marshall, has just been published by Granada at £5.95. It has chapters on each of block graphics, pixel graphics and line graphics, which explain the basic programming techniques and gives many programming examples.*



NEW FROM THE DESIGNER OF GRIDRUNNER

SO GOOD IT WILL BLOW YOUR MIND!!

SO FAST IT WILL BLOW YOU AWAY!!

The BIGGEST ADVANCE in Video Games design since Defender hit the Arcades!

Experience Laser Zone-an utterly NEW, TOTALLY ORIGINAL MASTER-PIECE of Video Games Design!!

Learn to control two spaceships at once. FEEL THE EXHILARATION as, after long hours of practise, you control the two ships so that they function as a SMOOTH, CO-OPERATIVE TEAM!!

LASER ZONE. Quite simply the BEST VIC-20 Game in existence!!



Feel the RAW POWER as you lunge for the Electro Button and BLAST your enemies into expanding clouds of SPACE JUNK!!

Laser Zone requires a Joystick, 8 or 16k, and DEDICATION!!

FEEL THE HUMILIATION as a carelessly -aimed BLAST SLAMS into the side of your last remaining ship!!

Designed and Programmed by Jeff Minter for the VIC-20 with 8 or 16k Ram Pack. If you don't yet have the memory, LASER ZONE IS THE ONLY EXCUSE YOU NEED TO BUY IT!

£6.00

A COMMODORE 64 version will be available soon.

Super Quality Software from \* LLAMASOFT \*

J = JOYSTICK CONTROL

VIC 20

ABDUCTOR

A classic new space game! ZAP the swirling alien hordes before they ram you — and abduct your humanoids! Survive the assault for long enough and you'll get an extra stage on your spaceship-with double firepower! Awesome unexpanded Vic Action. £6.00 + 50p P&P.

GRIDRUNNER

Finally, true arcade quality on the unexpanded VIC! Shoot down the segmented DROIDS invading the grid. Beware of the pods and zappers! The awesome speed, sound and graphics gives you the best blast available for unexpanded Vic. £6.00 + 50p P&P.

ANDES ATTACK (8K)

Your spacecraft must attack the descending aliens and frustrate their evil intent. Fly your Ramjet fighter over the Andes mountain range and protect your llamas from kidnap by hostile UFOS. Features 5 kinds of UFO, controls include up, down, reverse, fire, thrust and smart bomb. Entirely in machine code. Requires 8K expansion and joystick. £8.00 + 50p P&P.

TRAXX M/C (8K + EXPANSION)

This is VIC 20 cross breed between the now famed 'Pacman' and the game 'Quix'. All in machine code, fast and fun with joystick controls, uses Hi-Res colour graphics. 8K or larger expansion needed. Only £6.00 + 50p P&P complete with instructions.

BLITZKRIEG

As seen at the Commodore show and reviewed by the Daily Telegraph. Fly your Vulcan Bomber over the enemy city and destroy the buildings. 25 levels of play, uses Hi-Res colour graphics and plays Rule Britannia between waves. Only £4.95 complete with instructions.

THE VERY FIRST COMMODORE 64 GAMES

ATTACK OF THE MUTANT CAMELS

Planet earth needs you! Hostile aliens have used genetic engineering to mutate camels from normally harmless beasts into 90 foot high, neutronium shielded, laser-spitting death camels! Can you fly your tiny, manoeuvrable fighter over the mountainous landscape to weaken and destroy the camels before they invade the human stronghold! You must withstand withering laser fire and alien UFOS. Game action stretches over 10 screen lengths and features superb scrolling, scanner, 1/2 player actions and unbelievable animation! Play this game and you'll never be able to visit a zoo again without getting an itchy trigger finger! Awesome m/c action! £8.50 + 50p P&P.

ROX-64

Rox is a challenging game involving the defence of your lunar base from a deadly meteor shower. Rox-64 includes amazing sprite graphics displays and spacy sound effects, and an awesome 'mothership' display if you win the game. Top 10 scores are tabled along with their names. This program shows just what can be achieved using only Commodore-64 basic. Study the listing and learn how to use sprites and sound on this outstanding machine. £4.95 + 50p P&P.

GRIDRUNNER 64

The No. 1 best game for the Vic has been improved for your COMMODORE 64! Gridrunner

is a smash hit in the USA. Now experience the lightning-fast challenge of the grid on the 64. Features 31 skill levels and excellent sound and graphics. Sore trigger finger free with every game! £8.50 + 50p P&P.

SPECTRUM

GRAPHICS CREATOR (16K)

Not just another character editor! Allows you to define not only the 21 user definable characters. Also allows you to change the entire 96 character ASCII set. Creates BYTES files ready for you to load into your own programs. Includes advanced Reflect, Invert, Field commands etc. Complete with full documentation, Bin the BIN statement and use Graphics Creator with its easy on-screen cursor editing. £2.95 + 50p P&P.

BOMBER (16K)

Yes, a full feature version of the popular game 'Blitz', supplied for the 16K or 48K Spectrum. For only £2.95 + 50p P&P.

HEADBANGER (48K)

Colourful new game starring Chico the headbanger who you must guide to riches through an increasing shower of heavy metal. Gain bonuses for headbanging but be sure to take an aspirin when the pain gets too much! Basic + m/c to speed up action. Great graphics, nice animation. Will even drive William Stuart system's voice synthesiser to produce speech output. Can you attain the grade of 'Rocker Class One' or will you be 'Barry Manilow Class 5'? Start headbanging to-day and find out. £4.95.

SUPERDEFLEX (48K)

Bounce 'Sid', the space invader, around the screen into the power pods, keeping away of course from the devil who chases you around the screen. Steer with your Deflex shields, but beware the mines or you may be buried alive! Superb graphics and fantastic sound on the 48K Spectrum only. Only £4.95 on cassette + 50p P&P.

ATARI 400-800

TURBOFLEX

Superb ultra-fast and totally new ball game. Uses ATARI's unique features to the full. Incorporates superb colour/sound effects and uses Player/Missile graphics. Tables top 10 scores along with Scorer's name. £6.00 + 50p P&P.

GRIDRUNNER

100% machine code version of the best selling VIC/COMMODORE 64 game. Runs on any ATARI (16-48K). Blinding speed and superb graphics. Experience ATARI quality without paying ATARI prices — GRIDRUNNER for ATARI is just £8.50. Supplied on autoboot cassette. Discover the fastest and most exhilarating blast-em-up game ever devised. Only £8.50 + 50p P&P.

ZX81

CENTIPEDE (16K)

the ORIGINAL game from the ORIGINAL author. This is the identical program to that being sold by other companies for three times our price. The game has received ecstatic reviews in the computing press. Program has 30 speed levels and ever increasing Centipede hordes. Tables top 10 scores and names. Why wait to pay more? Only £1.95 + 50p P&P.

LLAMASOFT SOFTWARE



Dept CV8, 49 Mount Pleasant, Tadley, Hants RG26 6BN. Tel: 07356-4478. Trade enquiries welcome.

Please add 50p P&P with all orders

# MACHINE CODE

## YET MORE INSTRUCTIONS

We have already looked at *conditional jump instructions*, and now we turn to another set of instructions, which are often used in conjunction with these — called *comparison instructions*.

These comparison instructions subtract an operand from a register specified in the instruction. Only the flags are affected, the sign, zero, carry and overflow flags being changed according to the result of the subtraction.

On the Z80 the comparison instructions all work with the accumulator. The opcode mnemonic is CP, and the

CMPB, CMPD, CMPS, CMPU, CMPX, CMPY, for compare with A, B, D, S, U, X, Y registers.

The operand must be of the same length as the register specified in the mnemonic, so CMPA and CMPB take an 8-bit operand and the others take a 16-bit operand.

These compare instructions are available in immediate, extended, and other addressing modes. For example, we may have:

CMPA data: Compare A with the 8-bit data provided in the instruction

CMPX data: Compare X with the 16-bit data provided in the instruction

CMPB address: Compare B with 8-bit contents of address

CMPS address: Compare S with 16-bit contents of address and address+1



addressing modes we can use with this mnemonic include:

CP data: Compare the accumulator with the 8-bit data provided in the instruction.

CP register: Compare the accumulator with one of the registers A, B, C, D, E, H, L.

CP (HL): Compare the accumulator with the contents of the memory location whose address is in the register pair HL.

The 6502 and 6809 allow comparison with other registers as well as with the accumulator.

On the 6502 we have the mnemonics CMP for compare with accumulator, CPX for compare with X register, and CPY for compare with Y register. The addressing modes we can use with these mnemonics include:

CMP data: Compare the accumulator with the 8 bit data provided in the instruction.

CMP address: Compare the accumulator with the 8-bit contents of the 16-bit or 8-bit Zero Page address.

Similarly we have CPX data, CPX address, CPY data, and CPY address.

The 6809 has the mnemonics CMPA,

## TRUE AND FALSE FLAGS

The effect of a comparison instruction on the zero flag is quite straightforward: the zero flag will become 1 (meaning true) if the numbers being compared are the same, and 0 (meaning false) if the numbers are different.

The effect on the other flags is more complicated, and to understand what happens we have to look at the details of twos complement arithmetic.

You will remember that the Z80, 6502 and 6809 treat binary numbers with a 1 in the leftmost position (bit 7 of an 8-bit number or bit 15 of a 16-bit number, starting the count from bit 0 on the right) as being negative.

We can negate a number by first calculating the ones complement (by changing 0s to 1s and 1s to 0s) and then adding 1 to get the twos complement.

For example, if we start with the binary number 00001010 (equal to decimal 10) the ones complement is

11110101 and the twos complement is 11110110.

If you perform the same process starting with 11110110 you will get 00001010 and if you add 00001010 and 11110110 you will get 00000000 (and a carry of 1), so it does make sense to regard the twos complement of a number as its negative.

The easiest way to perform a subtraction in binary (for people, if not for microprocessors) is to add the twos complement of the number to be subtracted.

For example, to calculate 00001000 — 00000111 (decimal 8 — 7) we first calculate the twos complement of 00000111, which is 11111001, and then calculate 00001000+11111001, which gives 00000001 (and a carry of 1).

The 6502 actually uses this method of subtraction internally, so the program fragments

```
SEC
LDA 8
SBC 7
and
LDA 8
CMP 7
```

would leave 1 in the carry flag.

## PERFORMING SUBTRACTION

The Z80 and 6809, however, perform direct subtraction with borrow, giving a carry which is the opposite of the carry resulting from the twos complement and addition method. Thus the fragments

```
Z80
LD A,8
SUB 7
and
LD A,8
CP 7
6809
LDA 8
SUBA 7
and
LDA 8
CMPA 7
```

would leave 0 in the carry flag.

Subtraction of binary numbers using borrows (corresponding to the way we perform subtraction of decimal numbers) is complicated because of the difficulty of keeping track of the borrows, which may extend over several places.

It is much easier to perform a twos complement and addition, and if you are using a Z80 or 6809 remember to complement the resulting carry.

After an addition, subtraction, or comparison instruction, the sign flag will be the same as the leftmost bit of the result (bit 7 in an 8-bit operation, bit

BY TED BALL

15 in a 16 bit operation), 0 meaning positive and 1 meaning negative.

Thus, in the preceding example (8-7) the sign flag would become 0, while 7-8 would leave 1 in the sign flag.

Our microprocessors use a fixed number of bits in their calculations, but the results may require more bits than are available.

## CARRYING THE FLAG

The carry flag is used to record the carry from the leftmost bit, and this is all we need in unsigned binary arithmetic (where we regard the 8-bits as representing numbers from 0 to 255 decimal).

However, in signed binary arithmetic the sign and carry flags are not enough to tell us whether or not the result has the correct sign. Consider the calculation of decimal 70+80 in signed binary:

```

70      01000110
+ 80    +01010000
-----
150    (0)10010110 = -106 decimal
    
```

Adding two positive numbers has given a negative answer, because the carry from bit 6 has gone into the sign bit.

We get a similar result from (-70)+(-80)

```

-70     10111010
+-80    +10110000
-----
-150   (1)01101010 = +106 decimal
    
```

In this case adding two negative numbers have given a positive answer.

The same kind of thing can happen with subtraction, for example -70-80 (should be -150), and 80-(-70) (should be +150)

```

-70     10111010
+twos complement
of 80    +10110000
-----
-150   (1)01101010 = +106 decimal
    
```

```

80      01010000
+twos complement
of -70   01000110
-----
-150   (0)10010110 = -106 decimal
    
```

## THE WRONG INDICATIONS

The overflow flag is used to indicate when the result of a signed binary calculation has the wrong sign because 8 or 16-bits is not enough to record the correct signed binary answer.

The overflow flag will become 1 when the result of an 8-bit addition, subtraction, or comparison is more than +127 decimal or less than -128 decimal, and 0 otherwise.

Similarly, a 16-bit operation will give an overflow of 1 if the result is more than +32767 or less than -32768, and an overflow of 0 otherwise.

The value of the overflow flag can be calculated from the carries from bits 6 and 7 in an 8-bit operation, or bits 14 and 15 in a 16-bit operation. The overflow will be 1 if the two carries are different and 0 if the two carries are the same.

We can now return to the use of the comparison and conditional jump instructions. In Basic the simplest conditional jumps have the form IF *condition* THEN GOTO *line number*, where *condition* is one of the relations M=N, M<>N, M<N, M>N, M<=N, M>=N.

## TRANSLATING LANGUAGE

Now that we know how to work out what the flags will be for the various cases =, <, >, <=, >=, we can translate these IF... THEN... statements into assembly language (but needing several lines to replace the single line of Basic)

There is no difficulty in testing for = and :

Z80	LD A,M CP N JR Z,SAME ...	: Code to handle <>-case
	...	: Code to handle <>-case
SAME	...	: Code to handle = case
	LD A,M CP N JR NZ,DIFF ...	: Code to handle - case
DIFF	...	: Code to handle <>-case
	...	
6502	LDA M CMP N BEQ SAME ...	: Code to handle <>-case
	...	: Code to handle = case
	LD A,M CMP N BNE DIFF ...	: Code to handle - case
DIFF	...	: Code to handle <>-case
	...	
6809	LDA M CMPA N BEQ SAME ...	: Code to handle <>-case
	...	: Code to handle = case
	LD A,M CMPA N ...	: Code to handle - case
DIFF	...	: Code to handle <>-case
	...	



## SIMPLE TESTS FOR RELATIONS

The 6809 has an extensive set of conditional branch instructions, allowing us to make simple tests for all of the relations =, <, >, <=, >=.

We have BEQ for =, BNE for <>, BLO or BCS for unsigned <, BLT for signed <, BHI for unsigned >, BGT for signed >, BLS for unsigned <=, BLE for signed <=, BHS or BCC for unsigned >=, BGE for signed >=.

With the more restricted conditional branches or jumps on the 6502 and Z80 some relations are difficult to test, but they can all be worked out if you understand the principles of binary arithmetic.

For example, consider the problem of testing for signed <.

If M<N we will get M-N<0 (sign flag 1) when there is no overflow (overflow flag 0), and M-N>0 (sign flag 0) when there is overflow (overflow flag 1).

For this test we will therefore need to do something like:

6502	LDA M CMP N BVC L1 BPL LESS ...	
	NOTLESS	...
L1	BPL NOTLESS LESS	...
	...	
Z80	LD A,M CP N JP PE, L1 JP P, LESS ...	
	NOTLESS	...
	...	
L1	JP P, NOTLESS LESS	...
	...	

# THE INVASION HAS BEGUN

The assault on your senses has begun with a great choice of games that have been created to give you a real challenge!

ARCADIA

SCHIZOID

the name of the game especially created to be the most addictive shoot 'em up you've ever desired. With loathsome and devious billow hypnotically fighter with dev... But then you... on Ion Thr...

..the name of the game

the fastest movement  
 em up, come  
 d. Wo  
 dead  
 nically  
 at de  
 in Th  
 you h  
 Thru  
 100% machine code with 12 different alien types,  
 smooth hi-res multicolour graphics and animation, narrow  
 keyboard or joystick.  
 Game design and software by D. H. Lawson.

**ZX SPECTRUM (16K or 48K)**  
**VIC-20 (any memory size)**

100% machine code with 12 different alien types,  
 smooth hi-res multicolour graphics and animation, narrow  
 keyboard or joystick.  
 Game design and software by D. H. Lawson.

**for any ZX SPECTRUM.**  
 It's my own fault, I even volunteered.  
 I thought that with the space-dozzer and its shovel and skyhook  
 it would be easy shifting the galaxy's rubbish.  
 But they didn't say I'd have to stop and control not just one but two  
 the troy's, the rods, and all the rest.  
 Panic, and so lonely, so empty.  
 spinning and turning, always turning, towards me, against  
 me, at me. And I'm alone.  
 No way out, nowhere to hide, on my own, my own... own...  
**SCHIZOIDS: NOT JUST A GAME, BUT A STATE OF MIND.**  
 breathtaking visual experience, plus sound and all those arcade  
 features you'd expect from IMAGINE.  
 Game design and Software by Peter Paranoid and  
 the Yid Kids. (D.H.L.)

the wildest, zaniest way of earning a  
 fast buck. With crazy guests screaming for  
 service you're gonna have to be  
 quick to pick up the tips, don't slop the drinks,  
 as you dodge the drunks, don't slop the drinks,  
 dart from elevator to elevator, coz if the Boss  
 man spots you, your gonna be  
 out on your but. 100% machine code,  
 incredible animation, super smooth hi-res  
 multicolour graphics, authentic  
 sound effects and special joystick control.  
 Yet another high performance  
 Arcade quality experience  
**for any Commodore**  
 Game design and  
 software by  
 Eugene Evans.



**WACKY  
 WAITERS**

# WATCH OUT FOR THEM...

## catcha Snatcha



Barney  
bootface  
had never had  
it so bad, demoted  
from ace detective of  
the aristocracy to the  
level of a mere store  
detective he wanders his  
now well worn beat around the  
jewellery and watch counters  
considering his predicament  
life for the hardened criminal  
he has to look after the most  
valuable umbrella in the city  
lost property office and  
expect the cops to find it  
excitement  
CA+ 1A  
T-1-1-1

Any of these games for just

**£5.50**  
EACH

including first class post,  
packing, VAT and an  
**UNCONDITIONAL  
LIFETIME GUARANTEE**

When you buy Imagine Software you buy it for life. If an Imagine Software product EVER fails to load first time simply return it to Imagine for an instant free replacement.  
**All orders despatched by first class post within 24 hours of receipt.**

Why not put a first class stamp on your envelope and you will receive your order within 3 days of posting.  
Available from all good software outlets.

dealership enquiries contact: Mark Butler



**..the name  
of the game**

Imagine Software, Masons Buildings, Exchange Street East, Liverpool

and the  
enters  
comen vs a hectic  
ed crim fighter when  
ter lo children and return  
ty off. Of course to the  
ne occasional handbags to the  
plants. Of course one can  
bomb to add to the fun and

**CATCHA SNATCHA** brings to your screen the mad, mad world of the exotic super store ever built with hordes of harassed housewives doing their weekly shopping. And you just wait till the late-night shopping starts.

**CATCHA SNATCHA** features smooth Hi-Res multicoloured graphics, sound, 100% machine code. Keyboard or joystick.

Game design and software by Eugenie Evans.  
for any Commodore Vic-20.

**for any ZX SPECTRUM.**  
Are you just the average teddy. Are you teddy enough to take on the terrors of the true role in life - to reach and comfort your crying baby? To boldly go where no teddy has gone before. To overcome incredible odds, to take on and fight the clockwork soldiers, the mammah dolls, the train set, the play people, and the murderous plastercine.

With only the bear essentials - your wellington boot, your beachball and faithful old peashooter - for your defence and your only ally the Jack in the Box, you will need to build stairways from the play bricks around you to reach your baby without getting the stuffing knocked out of you.

**AH DIDDUMS** features multiple toyboxes with progressive difficulty levels, super cute - super detailed animation, sound and those fast smooth graphics that only IMAGINE can produce.

100% machine code.  
Game design and software by D. H. Lawson.



Post coupon now to Imagine Software, Masons Buildings, Exchange Street East, Liverpool, Merseyside L2 3PN.

Please rush me copies of (tick box)

Arcadia  Schizoids  Arcadia  Wacky Waiters

Ah Diddums  Catcha Snatcha

(for any ZX Spectrum) (for any Commodore VIC-20)

Please debit my Access/Barclaycard (delete as necessary)

Card Number

I enclose Cheque/PO for £

Name

Address

CVG4

**SUPERFAST CREDIT CARD SALES LINE:**

**051 236 6849 (24hrs)**

ACCESS BARCLAYCARD VISA

# Projects

## LOGIC CHIPS, PHASE CLOCKS

One of the main problems associated with some of the newer microprocessors is that they seldom have a phase 2 clock.

This is really of no problem to kit builders as it is a simple inversion of phase 1. It is quite possible that you will have in your system, either a line which is phase 2 or a spare gate on a logic chip.

It would be easy to suppose that this was a hex inverter but I will not assume that here.

In figure 1 I have indicated the way in which two popular logic chips can be used as an inverter.

If you are unfortunate enough not to have a spare gate on any of your logic chips I would recommend using a two-input nand gate, say a 7400 or similar, as this is one of the most useful chips available.

### SMALL SYSTEMS

For those with small systems it will come as a surprise that it will be easier for you to install this timer. Of course, the chip must be accessed using the address lines.

If you already have 64k bytes of memory installed the question becomes, where do you put the timer? There is no simple answer to this.

The easiest way of course is to remove a 1k-byte of memory somewhere. That used to be an easy job, but since the coming of 16k-by-1 and 64k-by-1 chips this is not so.

I would therefore risk dual addressing of memory and timer at the same time. The problem comes, of course, when you come to read information from the timer.

Fortunately, these days systems are built with several user ports available. Some of these will already be used by PIA's, ACIA's and other system-defined I/O's. (If you do not already use the PIA, if you have one, try the onboard clock facility.)

There is no real problem in connecting up the address lines. Find out in hex notation where the port lies, or better in binary, and tie CS1 to this line. CS0 will be the line below.

For example, say the port is at 8010 hex, or 1 followed by 15 zeros in binary. Therefore you would put CS1 to line 15 and CS0 to line 14.

This ties in with what I said last month, that to address the chip CS0 must be at zero and CS1 must be at one.

The register select lines could then go on any of the first ten address lines. If, for example they were put on lines 0-2 the addresses in hex would be from 8010 to 8017 or in decimal 32,784 to 32,791.

Now, with the data, address and clock lines connected you are almost ready to start timing. It is not necessary at this point to connect either the IRQ or reset line.

The only necessary one left is the read/write line, again, this interfaces directly with the microprocessor.

Once this is done you must decide on the frequency of your timer clocks. The most convenient method of deriving a lower frequency that I have found is to use a divider chip.

The CMOS 4040 is quite useful, allowing up to 12 different frequencies to be selected. Unfortunately, this is a binary counter and therefore divides in powers of 2.

Hence, for a 1MHz input you can get outputs of 500kHz, 250kHz, 125kHz, 62.5kHz, 32.15kHz, etc. There are a large number of decimal dividers on the market which are as handy as they usually divide by multiples or powers of ten. Unfortunately, these are not yet as common as the 7400 or 4000 series chips.

You are now ready to load into the timer and to set it in motion, (if such a word can be applied to time). You will, by now, have access

to eight internal registers. I will refer to them as RO-R7.

Each timer — remember there are three — has its own control register, data latch, and buffer register.

The first, the control register lets you decide in which mode that particular timer is in. Unfortunately there is not enough room here to explain all the modes suffice to say that there is a lot of supplied information with the chip when you buy it.

### LOTS OF EIGHT

To load 16-bits into the counter two lots of eight must be entered separately. For example, to load into timer 1 write the 8 most significant bits into R2 and then the least significant bits to R3.

This second instruction puts both the MSB and the LSB into the 16-bit counter at the same time. Depending on the state of the control register the timer will either initialise or await an external trigger.

It is most important that the control registers are loaded with the correct bytes or else the timers will not work.

Now, with this timer quite a few more programs are possible than you might have imagined. Not only can it be programmed as a tone burst generator for fault finding on such things as cassette recorders, but also can be used as a tone generator for synthesising music.

As there are three timer many more contrived sounds may be produced. The module has been designed to drive two TTL loads so you may not even need to amplify the output for playing through a normal pair of headphones.

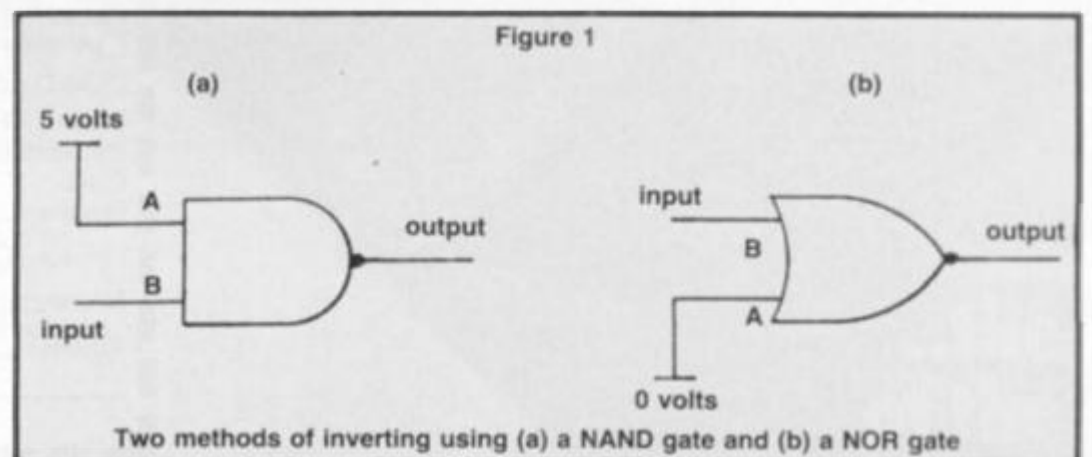



# Projects

## Truth Tables

NOT gate.

Input	Output
0	1
1	0

Symbol

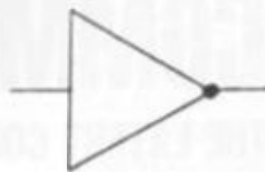

AND gate.

Input A B	Output
0 0	0
0 1	0
1 0	0
1 1	1

Symbol

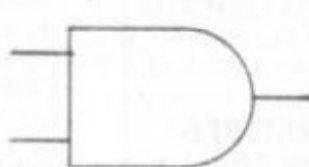

NAND gate.

Input A B	Output
0 0	1
0 1	1
1 0	1
1 1	0

Symbol



OR gate.

Input A B	Output
0 0	0
0 1	1
1 0	1
1 1	1

Symbol

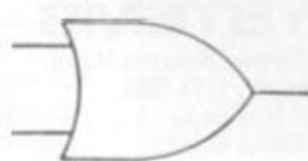

NOR gate.

Input A B	Output
0 0	1
0 1	0
1 0	0
1 1	0

Symbol



## A LITTLE ON DIGITAL LOGIC

Some of you may have come across truth tables for logic gates or you may have played about with some small chips at some time or another.

In the figure below I have shown a few of the symbols which are used to represent the gates I have mentioned. There is not enough room here to cover the whole subject of digital logic so I will not try. All that I will show is a small section relevant to the project.

Above I have mentioned an inverter, a nand gate and a ripple counter, the 4040. The 4040 is too complex to mention here. The other two I will describe to you.

### The Inverter or NOT Gate.

This is a one input, one output gate, of which a number are built into a single chip. It takes a logic level and inverts it. If a logic one appears on the input logic zero appears at the output and vice versa. This can be shown in the form of a truth table.

### The AND Gate.

To describe a NAND gate we must first consider the AND gate. The simplest AND gate has two inputs but only one output. As you can see, for the output to be a one both inputs must be at logic one. Any other condition and the output is a logic zero.

### The NAND Gate

Imagine an AND gate followed immediately by an inverter. This is the NAND gate. Whatever appears at the output of the AND gate is inverted as is shown in the diagram.

### How to use a NAND gate as an inverter.

By taking one input of the NAND gate to the 5 volt rail so as to make it a logic one you will see that the output follows that of the NOT gate. We therefore have a NOT gate from a NAND gate, and this is why the NAND gate is so useful.

### The OR Gate.

This is a logic gate in the same form as the AND. It usually comes in a chip package along with others of its kind. In this instance the only case when a zero is present at the output is when both the inputs are zero. If one OR the other input is a one then the output is a one, as shown in the truth table.

### The NOR Gate.

This is an OR gate followed by an inverter or NOT gate. Whatever is on the output of the OR gate is immediately inverted for the output of the NOR gate. This is again shown in the tables.

### How to use a NOR gate as an inverter.

Looking at the truth table for a NOR gate we can see that by taking one of the inputs to logic zero the output will be an inversion of the other input. This is also a handy gate to have around and perhaps just as good as the NAND.

# ZX81 GAMES

from  
J.K. GREYE SOFTWARE LTD

## PLEASE NOTE

As from March 31st the ZX81 games currently available from this company will be marketed solely by two separate companies as follows

Gamestape 1 — 10 Games for 1k

Gamestape 2 — Starfighter, Artist Pyramid

Gamestape 3 — Catacombs

From J. K. Greye Enterprises,  
16 Park Street,  
Bath.

Gamestape 4 — 3D Monster Maze

Gamestape 5 — 3D Defender

Gamestape 6 — Full Screen Breakout for 1k

From New Generation Software,  
16 Brendon Close,  
Oldland Common,  
Bristol.

Any enquiries concerning the above games should be made to the respective companies.

# SPECIAL FREE OFFER READ ON! COMMODORE 64

THE LATEST COLOUR COMPUTER WITH 64K MEMORY AND MUSIC SYNTHESIZER



### FEATURES

Full Colour, Music Synthesizer, High Resolution Graphics with sprites for 3D effects, Full Size Typewriter Keyboard, Pet Basic.

SPECIAL OFFERS AVAILABLE WHEN ORDERING FREE C2N DIGITAL CASSETTE DECK AND FREE JOYSTICK AND 5 DIGITAL CASSETTE TAPES OR JUST SEND £299.00 + CARRIAGE AND WE WILL PAY THE VAT

### THE FOLLOWING ITEMS NOW AVAILABLE

- i. VIC 64 Colour Sound Computer (64K) £299.00 + VAT
- ii. VIC 20 Colour Sound Computer £125.00 + VAT
- iii. VIC Joystick Control £6.52 + VAT
- iv. VIC single disk drive (170K) £260.00 + VAT
- v. VIC C2N Digital Cassette Deck £39.08 + VAT

NB Full 12 Months Parts and Labour Warranty

## IBEK SYSTEMS

437 Stoney Stanton Road,  
Coventry, CV6 5EA,  
West Midlands.  
Tel: (0203) 661162

TOTAL	£	
+ CARRIAGE	£	3.45
+ VAT @ 15%	£	
	£	

\*I enclose Cheque/Postal Order for £

\*Please charge my Barclaycard/Access No.

--	--	--	--	--	--	--	--	--	--	--	--	--	--	--	--	--	--	--	--

\*Delete as required

Name: .....

Address: .....

Signed: .....

Or telephone order.

CVG 4/83



## CINDERELLA AND THE BEANSTALK

Every now and again in an Adventure something dramatic must happen — or it wouldn't be an Adventure!

This may be the appearance of a cryptic clue to heighten the excitement and add to the atmosphere, or the transformation in some way of an object or location.

A verb routine cannot usually achieve this end, as some of these events will be unique. For example, the transformation of mice and pumpkin into Cinderella's coach and horses will be carried out magically by the fairy godmother as soon as all necessary conditions have been met.

This involves the mice, pumpkin, godmother and player all being in Cinderella's house at the same time.

Similarly, if there is a secret exit from the drawing room of a house via a moving bookcase, you might wish to draw attention to it occasionally by giving the clue "There's a draught coming from under the bookcase".

With a clue like that, you can make the mechanism for opening the exit quite complex, as the player will be fairly certain it is worth persevering.

Recapping on our method of screen display, we settled for setting variable Q1\$ for the computer's reply to the move, return to the start of the main game loop (Block 3 we called it) at line 100.

This block checks for special conditions before the screen is cleared and redisplayed. It is these special conditions we have now got to insert.

Let's tackle the clue first. We are at the top of the beanstalk we grew so painstakingly a few months ago, and wish to display "FEE-FI-FO-FUM" whilst in this location.

The "GO" or moving verb routine cannot be used, since then the message would only appear on entry to the location.

If we spend some time there it will not re-appear. Letting the top of beanstalk be location five (i.e. LN%=5 when there) then we can insert line 110:  
110 IF LN%=5 THEN LET Q2\$="FEE-FI-FO-FUM".

Now when the computer has worked out the response to the latest command, it will automatically set Q2\$ to the re-

I sat with eager anticipation as Philosopher's Quest loaded into the BBC Model B micro in front of me. The Acornsoft logo appeared across the screen in four colours, broken by the title of the game, whilst the blocks loaded before my eyes in hex.

When the game started I was treated to silent scrolling text in black and white. OK, so an Adventure doesn't require colour or sound, but it seemed a shame not to take some advantage of the Beeb's facilities — the machine wasn't being used to the full.

Having got that off my chest, what of the Adventure itself? It starts off in a shop that has peculiar qualities.

Nothing has to be paid for, but you can only leave with two items. If the four objects lying around, keys, in my experience, were a must. So that left a choice between an aqualung, steel rod, and cup of tea that couldn't be drunk (said so in the rules).

I opted for the rod, and set off, only to find myself in pitch darkness.

Now newcomers to Adventures might be thrown off balance by having had no chance to acquire a lamp. Not so those of us who have traversed the ancient pyramids, been stuck in quicksand bogs, mauled by bears, and gone insane trying to escape from the Asylum. "XXXX XXXX", I boldly typed, and I was duly rewarded!

Thereafter I proceeded to explore the labyrinth, which has many puzzles to solve. Unfortunately, in attempting to solve them I was frequently thwarted by being turned into a lettuce, ceasing to exist, and various other nasty things.

However, restarting was not too difficult since it was only necessary to reload the database part of the program — a task taking about a minute.

Thus, eventually I got an Albatross (no wafers!), some ripe cheese, and many

quired message if the current location is set at five.

The display lines will now look like this:  
190 PRINT "YOU TOLD ME TO"; R1\$: IF LEN(Q1\$)>0 THEN PRINT Q1\$ : IF LEN(Q2\$)>0 THEN PRINT Q2\$

Thus Q2\$ will only get printed if set. Remember that these variables must be nulled (ie LET Q1\$="" ) after display.

**BY KEITH CAMPBELL**

times wore out the seat of my trousers on the slides.

I've heard of but not come across the automatic solicitor, nor recovered from ceasing to exist. I am told it is possible to do this, and the key is philosophical.

Those people I know who are into the game just give me a distant smile when I ask how near they are to completing it. Presumably their minds are miles away, philosophising!

Good points — cunning and complex plot. Bad point — poor response time, up to about five seconds when the machine does any serious thinking.

Scott Adams' first adventure was my introduction to Adventure gaming, and although it fired my imagination, little did I realise it was going to make Adventure a major part of my life!

The original version was written in Basic for the TRS-80 and Pet, and later translated into machine code, available for the TRS-80, Apple and Sorcerer.

Like all Scott's Adventures, it has recently been released for the Vic-20 and Atari computers. This may explain why I am currently receiving a flurry of pleading letters from readers who are desperately stuck — a whole new generation of Adventurers!

It is probably *the original* adventure as far as micros go. I regard it as a classic, and still relive the thrill I first experienced whenever I bring it up on the screen.

The major problem in this game seems to be how to get past the thin bear. If you've got that far you're capable of completing the journey!

What do bears do to people? OK — reverse roles, and then (disappointingly) rephrase it!

To those currently playing Adventureland — don't give up. It IS soluble.

If you are struggling, get together with others in the same position — Adventures are fun when played in company.

A further refinement is possible to cause the message to occur at random, keeping the player guessing whether or not the giant is about to attack, rather than risking him deciding that the message is automatic.

110 IF LN%=5 AND RND(3)=2 THEN LET Q2\$="FEE-FI-FO-FUM"

This will bring the message up about one turn in three. Next we will see how to carry out transformations that take the game into a new phase.



# WARPATH

*Bigscreen will help you to map out a wargame which goes beyond the borders of your screen. Part four of Ron Potkin's wild west game*

**D**URING the past three articles, I have described a number of important arrays: BIGSCREEN, IBOARD and PTABLE. After studying last month's explanation, I think that you will now understand the basic module and be able to see how the arrays fit together. They are very large, totalling almost 6000 bytes which is a big slice out of a 16K memory.

The largest of these is BIGSCREEN which requires 4000 and although this might appear wasteful, it provides considerable flexibility and is easy to operate. It enables me to draw any map feature and save it permanently in memory so that, during the course of the game, the program is able to recall any portion of the map and display it in the WINDOW.

This method is only viable with low resolution graphics; high resolution would require a BIGSCREEN of not 4000 but 20000 or more! In this case, the alternative is to write a machine language routine which reads the contents of IBOARD, selects the appropriate feature from a character set and prints it on the screen.

I am going to concentrate on a single routine. The Basic listing is quite short but is an integral part.

It is clear from the rules that the program must check a hex and its neighbours at every move. The hex that a player wishes to move to must be checked first. This can be done in Basic, but checking the six surrounding hex is slow and this is carried out in machine code. This routine is called SEARCH and is held in XS(4).

Take another look at IBOARD and BIGSCREEN. Hex are awkward to deal with and you can see the problem from the following extracts from the arrays.

This diagram shows two small parts of BIGSCREEN showing a piece on an odd row X264X and a piece on an even row X396. The six surrounding hex are shown in brackets.

BIGSCREEN			
ODD			
0	(8)		16
(132)	x264x	(140)	
256	(388)	(396)	272
512	(520)		528
EVEN			
132		(140)	
256	(264)		(272)
388		x396x	
512	(520)		(528)
644		(652)	

Now compare these with the equivalent positions on IBOARD:

ODD		EVEN	
0	(1)	2	24 (25) 26
(24)	(25)	26	48 (49) (50)
48	x49x	50	72 x73x 74
(72)	(73)	74	96 (97) (98)
96	(97)	98	120 (121) 122

Let's assume the man on x49x is to be moved in direction 1. What hex number do I test? It must be 25 which is 24 less than 49, but what if the man is on x73x? Then direction 1 gives 50 which is 23 less. You can see that the offsets for the two are different and depend on whether the row is even or odd i.e.:

Direction	1	2	3	4	5	6
Odd Row	-24	24	48	23	-25	-48
Even Row	-23	25	48	24	-24	-48

Now perhaps you will forgive me for sneaking in Line 1180! This table is in a 2 by 6 array (variable RF) and also in memory starting at RW (location 32606).

RF is used in Line 500 when testing whether the new hex is empty. Take a look at this line. Can you see how NB, the new hex position is calculated? The routine also returns NX, the contents of the hex and V2, its location in memory.

RW is used by SEARCH. This is the same thing, but we do it six times. We first POKE 6 into S9 and BL is passed to the USR routine. The route will not return until it finds a non-vacant hex, when it returns the contents. These are checked and then, if necessary, XS(4) is recalled. When it has completed the search, it returns with S9 equal to 255.

The interesting feature is the use of S9. The routine is really equivalent to FOR S9 = 6 to 1 STEP -1, but I cannot put this into the USR routine because each time it was entered S9 would be set equal to 6.

The answer is to set S9 to 6 in Basic and let the machine code decrement it. This is in the listing below which is annotated so that with the above explanation, I think you will find it understandable.

The Basic listing this month includes the lines necessary to load the machine code for XS(4). Once this is done, we will be able to start on the MOVE routine. Up to now, everything I have described can be used in any wargame — even hexagonal chess — but from now on we will concentrate on the details of Warpath and get the game underway.



# Sinclair ZX Spectrum

**16K or 48K RAM...  
full-size moving-  
key keyboard...  
colour and sound...  
high-resolution  
graphics...  
From only  
**£125!****

First, there was the world-beating Sinclair ZX80. The first personal computer for under £100.

Then, the ZX81. With up to 16K RAM available, and the ZX Printer. Giving more power and more flexibility. Together, they've sold over 500,000 so far, to make Sinclair world leaders in personal computing. And the ZX81 remains the ideal low-cost introduction to computing.

Now there's the ZX Spectrum! With up to 48K of RAM. A full-size moving-key keyboard. Vivid colour and sound. High-resolution graphics. And a low price that's unrivalled.

## Professional power— personal computer price!

The ZX Spectrum incorporates all the proven features of the ZX81. But its new 16K BASIC ROM dramatically increases your computing power.

You have access to a range of 8 colours for foreground, background and border, together with a sound generator and high-resolution graphics.

You have the facility to support separate data files.

You have a choice of storage capacities (governed by the amount of RAM). 16K of RAM (which you can uprate later to 48K of RAM) or a massive 48K of RAM.

Yet the price of the Spectrum 16K is an amazing £125! Even the popular 48K version costs only £175!

You may decide to begin with the 16K version. If so, you can still return it later for an upgrade. The cost? Around £60.

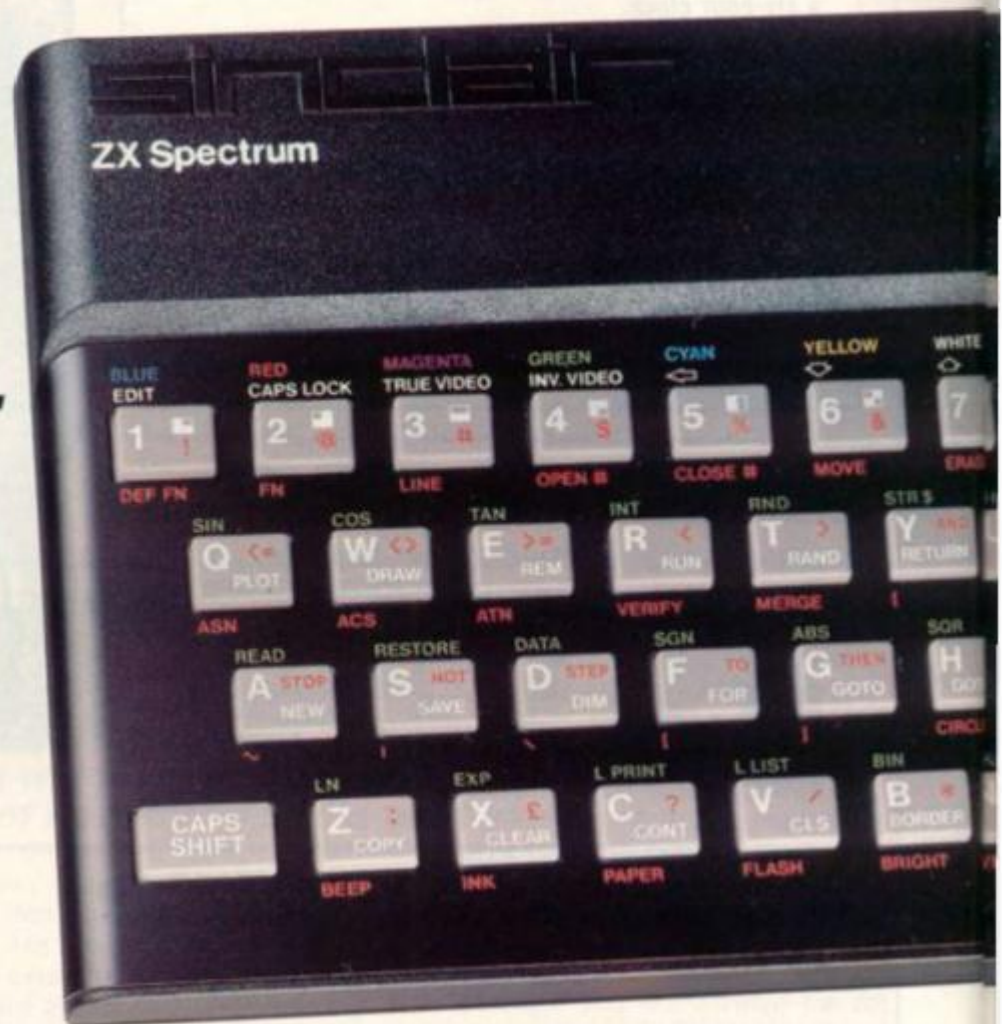

## Ready to use today, easy to expand tomorrow

Your ZX Spectrum comes with a mains adaptor and all the necessary leads to connect to most cassette recorders and TVs (colour or black and white).

Employing Sinclair BASIC (now used in over 500,000 computers worldwide) the ZX Spectrum comes complete with two manuals which together represent a detailed course in BASIC programming. Whether you're a beginner or a competent programmer, you'll find them both of immense help. Depending on your computer experience, you'll quickly be moving into the colourful world of ZX Spectrum professional-level computing.

There's no need to stop there. The ZX Printer—available now—is fully compatible with the ZX Spectrum. And later this year there will be Microdrives for massive amounts of extra on-line storage, plus an RS232 / network interface board.



## Key features of the Sinclair ZX Spectrum

- Full colour—8 colours each for foreground, background and border, plus flashing and brightness-intensity control.
- Sound—BEEP command with variable pitch and duration.
- Massive RAM—16K or 48K.
- Full-size moving-key keyboard— all keys at normal typewriter pitch, with repeat facility on each key.
- High-resolution—256 dots horizontally x 192 vertically, each individually addressable for true high-resolution graphics.
- ASCII character set—with upper- and lower-case characters.
- Teletext-compatible—user software can generate 40 characters per line or other settings.
- High speed LOAD & SAVE—16K in 100 seconds via cassette, with VERIFY & MERGE for programs and separate data files.
- Sinclair 16K extended BASIC—incorporating unique 'one-touch' keyword entry, syntax check, and report codes.

# rum

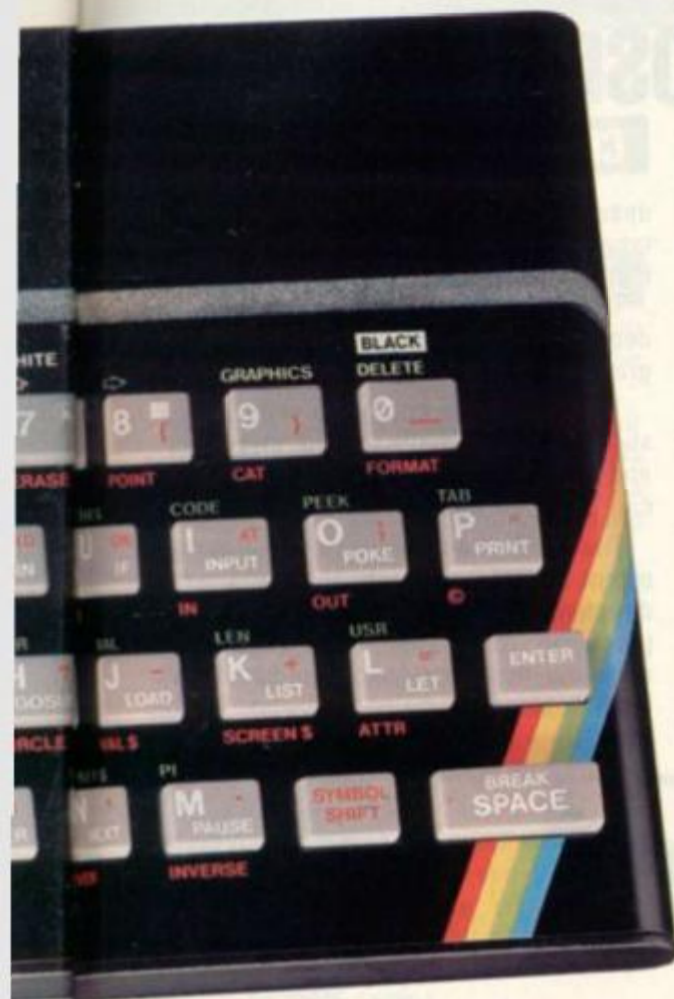

## The ZX Printer - available now

Designed exclusively for use with the Sinclair ZX range of computers, the printer offers ZX Spectrum owners the full ASCII character set - including lower-case characters and high-resolution graphics.

A special feature is COPY which prints out exactly what is on the whole TV screen without the need for further instructions. Printing speed is 50 characters per second, with 32 characters per line and 9 lines per vertical inch.

The ZX Printer connects to the rear of your ZX Spectrum. A roll of paper (65ft long and 4in wide) is supplied, along with full instructions. Further supplies of paper are available in packs of five rolls.



## The ZX Microdrive - coming soon

The new Microdrives, designed especially for the ZX Spectrum, are set to change the face of personal computing by providing mass on-line storage.

Each Microdrive can hold up to 100K bytes using a single interchangeable storage medium.

The transfer rate is 16K bytes per second, with an average access time of 3.5 seconds. And you'll be able to connect up to 8 Microdrives to your Spectrum via the ZX Expansion Module.

A remarkable breakthrough at a remarkable price. The Microdrives will be available in the early part of 1983 for around £50.



## ZX Spectrum software on cassettes - available now

The Spectrum software library is growing every day. Subjects include games, education, and business/household management. Flight Simulation... Chess... Planetoids... History... Inventions... VU-CALC... VU-3D... Club Record Controller... there is something for everyone. And they all make full use of the Spectrum's colour, sound, and graphics capabilities. You'll receive a detailed catalogue with your Spectrum.

## ZX Expansion Module

This module incorporates the three functions of Microdrive controller, local area network, and RS232 interface. Connect it to your Spectrum and you can control up to eight Microdrives, communicate with other computers, and drive a wide range of printers.

The potential is enormous, and the module will be available in the early part of 1983 for around £30.

# sinclair

Sinclair Research Ltd, Stanhope Road, Camberley, Surrey GU15 3PS. Tel: Camberley (0276) 685311.

## How to order your ZX Spectrum

BY PHONE - Access, Barclaycard or Trustcard holders can call 01-200 0200 for personal attention 24 hours a day, every day. BY FREEPOST - use the no-stamp needed coupon below. You can pay by cheque, postal order, Barclaycard,

Access or Trustcard.

EITHER WAY - please allow up to 28 days for delivery. And there's a 14-day money-back option, of course. We want you to be satisfied beyond doubt - and we have no doubt that you will be.

To: Sinclair Research, FREEPOST, Camberley, Surrey, GU15 3BR. Order

Qty	Item	Code	Item Price £	Total £
	Sinclair ZX Spectrum - 16K RAM version	100	125.00	
	Sinclair ZX Spectrum - 48K RAM version	101	175.00	
	Sinclair ZX Printer	27	59.95	
	Printer paper (pack of 5 rolls)	16	11.95	
	Postage and packing: orders under £100	28	2.95	
	orders over £100	29	4.95	
			Total £	_____

Please tick if you require a VAT receipt

\*I enclose a cheque/postal order payable to Sinclair Research Ltd for £ \_\_\_\_\_

\*Please charge to my Access/Barclaycard/Trustcard account no. \_\_\_\_\_

\*Please delete/complete as applicable \_\_\_\_\_

Signature \_\_\_\_\_

PLEASE PRINT

Name: Mr/Mrs/Miss \_\_\_\_\_

Address \_\_\_\_\_

\_\_\_\_\_

\_\_\_\_\_

CVG 904

FREEPOST - no stamp needed. Prices apply to UK only. Export prices on application.

## supermarket ...

### EMPIRE OF THE RAITH LORDS

COULD YOU FREE THE GALAXY FROM TYRANNY\*\* CAN YOU FIND THE CLUES, AND SOLVE THE MYSTERY OF THE CRYSTAL OF HELIOS.\*\*

A play by mail game and a race for freedom in the search for the crystal, which alone holds the key to the Raith Lords' computer system, PLUS a valuable REWARD for the finder. S.A.E. for more details. P. J. Sutton, Holmwood, Channells Hill, Westbury on Trym, Bristol BS9 3HY.

### TEXAS T199/4A SOFTWARE

Snake + Space Attack	£2.95
Fruit Machine + Blackjack	£2.95
Chalice of Kalmar + Penguin	£3.95
Haunted House + Wumpus	£3.95
Sorcerer's Castle + Lunar Lander	£3.95
3-D Maze + Towers of Hanoi	£3.95
Island Adventure + Four in a Row	£3.95
Pharaoh's Curse + 3-D O's & X's	£4.95

Please add 50p p&p to all orders under £6. Over £6 post free. Send cheque or P.O. or phone with Access/Barclaycard for same day despatch. S.a.e. for full list.

**APEX TRADING LTD. (Dept. CVT),**  
115 Crescent Drive South,  
Brighton BN2 6SB.  
Tel. Brighton (0273) 36894.

New Catalogue from Bulldog Software  
ATARI over 200 exciting tapes  
VIC 20 including MYSTERIOUS ISLAND 16K —  
superb graphics.  
GOLD RUSH } Both now £9.95  
THE PRIZE GAME }  
DRAGON — 3D SPACE MAZE — hi-res colour  
graphics — Only £5.95  
SPECTRUM Question Quest 1 (Maths) — super  
educational graphics adventure for all ages — Only  
£5.95  
For free catalogue send SAE (state computer)  
**BULLDOG SOFTWARE, 5 Chestnut Close,**  
Stalybridge, Cheshire  
TEL: 061 303 8486

### BROKEN YOUR TV/COMPUTER JOYSTICK?



Inside your joystick handle is a white plastic insert. (The main cause of failure.) Stronger insert replacements now available. Supplied with full fitting instructions allowing you to be back in action in seconds.

Send £2.50/pair inc. p&p  
to:  
**Computer Supplies, 146**  
Church Road, Boston,  
Lincs. PE21 0JX

### T&G SOFTWARE

15 STANDISH WALK,  
DENTON, CHESHIRE.

ATARI 400/800	Vic 20	VC1: Scramble 8k +
AC1: Attack Force		Simon 3.5k
Xasact	VC2: Galaxoid 19.5	
AC2: Questor		Vicman 3.5
Anti Matter	VC3: Questor 19.5k	
AC3: Hotty Hazard		Demon Driver

Cassettes £3.95 + 70p Postage.  
Please state memory capacity.

ATARI TEL: 061 338 4167 VIC TEL: 061 338 8752

### FREE SOFTWARE

YES, you can free our all M/C products for the Spectrum from my room.

**SNAKE** — bombs, gremlins, lasers, decaying food are just some of the awesome features of this game. Kempston and Fuller joysticks compatible. £4.90

**KIT-TOOL** — the only and best toolkit that has Search/Replace, Delete, FreMem, Renumbering of Goto, Gosub, Lists, Restore, Save and Run. £5.90

**BACKER** — can Save, Verify, Edit any program even Protected Commercial Tapes. £5.90

Full documentation on all cassettes.

Send P/O, Cheque, Cash to:-

**APOCALYPSE SOFTWARE,**  
5 & 7 Sturt Street, Abingdon, Oxford.  
All cassettes for 16/48K Spectrum.

# WARE SOFTWARE SOFTWARE SOF REVIEWS

## LET'S SAVE THOSE HOSTAGES!

### CHOPLIFTER

Remember the American hostage affair in which the staff at the Embassy in Iran were kept hostage by the fanatical student supporters of Khomeini? Then there was President Carter's abortive attempt to rescue the hostages with a commando style raid with choppers flying in low across the desert.

Some of the features of that attempted rescue have been incorporated in this latest game for the Vic 20, called Choplifter.

Choplifter is already a best selling game in the U.S., where versions for the Apple and Atari have been on sale for several months. It is not only the game's obvious associations with the hostage affair that have caused the game to be such a big hit in the U.S. It is by any standards a most playable game.

You pilot a helicopter on a mission to

desert and they will shoot down the hostages rather than let you get away with them.

There are also enemy jet fighters and deadly satellites which home in on you at great speed.

The chopper is controlled with the joystick and can be made to bank, dive, hover, and scroll backwards and forwards. You can bomb as well as shoot.

The bombs can be directed to a certain extent by making the chopper bank in the direction you want the bombs to fall. By practising you can catch out those annoying tanks by guiding a bomb onto them instead of being a flying "sitting duck"!



rescue the hostages that are waving at you from the ground. Land your craft and let them hop aboard. When you have picked up your maximum load of sixteen men, or as many as you can get away with, fly them back to the U.S. base and set off on another rescue mission.

But there are obstacles to your rescue attempt. Tanks appear to blast your helicopter once it lands. The best tactic is to take off and bomb the tank before returning for the frantic hostages.

Some of the hostages are imprisoned in camps so you will have to bomb these open in order to get at them.

We found an easier way to free the imprisoned hostages is to land the chopper on top of the prison and then take off again. The happy hostages soon come hopping out!

Your task is again made more difficult by those enemy tanks which are patrolling the

The movement of the rotor-blades has also been well done with convincing sound effects. And when you get blasted by a tank or passing jet there's a horrible metallic crashing sound.

Four readouts keep a check on the number of hostages on board, the number safely brought back to base, and the number killed. The high score is also recorded.

As might be expected the graphics on this version are not quite up to the standard of the Apple and Atari versions — though they are none the less impressive, and the game is every bit as playable as the other versions.

Very addictive and definitely one of the best games now on sale for the Vic. Choplifter is available at £24.95 from Audiogenic of Reading.

● Getting started	8
● Value	8
● Playability	9



# SOFTWARE SOFTWARE SOFTWARE SOFTWARE SOFTWARE SOFTWARE SOFTWARE SOFTWARE

# REVIEWS

## DRIVEN BATTY IN THE TUBE TRAIN TUNNEL!

### 3D TUNNEL

Some of the most impressive graphics you are likely to see on the Spectrum can be found in 3D Tunnel.

Bats fly towards you flapping their wings, toads that bounce up and down as they approach, and sinister looking rats which charge at you, snouts to the ground and wagging their tails.

There are also ugly black spiders that swing along the roof of the tunnel spinning their webs as they approach.

48K Spectrum owners have an extra treat at the very end of the tunnel, if they manage to get that far. A silver underground train hurtles out of the dark recesses.

The underground train is a masterpiece of programming. You can see the lights twinkling as it approaches. When it becomes larger you can even see the passengers in their seats and hear the rush of wind as the train passes.

My chief criticism of 3D Tunnel is that the games playability does not measure up to the high standards set with the graphics.

Although the sensation of depth is adequately created with an infinite number of concentric squares it is too difficult to manoeuvre.

Try as I might I could not get the bats in my sights. This is slightly compensated by the large choice of game options which enables you to jump to the next sequence — but even after two hours of play I could

## BEWARE BOUNCING MISSILES

Penetrator is the best Scramble type available so far for the Sinclair Spectrum. Running on the 48K model only, the graphics are truly impressive.

As with arcade Scramble it is not really your score that is of the utmost importance but how far you can get into the Scramble system. Penetrator challenges you to fly through four levels of progressive difficulty.

The first of these is gently undulating terrain with only the ground-to-air missiles to worry about. Soon after this you fly into a tunnel and you will have to move up and down with great precision.

The most difficult stage of the game is the maze with its sharp vertical drops and walls that appear suddenly in front of you.

Further still, and you come across bouncing missiles which fall down from the ceiling as if suspended on springs.

Your ship has five flight controls. Up, down, thrust, forward and brakes which



not get beyond the bats and onto the next wave through my own skill.

The missile graphics are not very clear — just one faint line of laser fire. And the screen blanks out every time you hit a creature, albeit only for a split second.

On the plus side the game offered a comprehensive list of game options including a choice of the three Spectrum joysticks now coming on the market.

Superb graphics and game presentation, but not for the non-persistent. 3D Tunnel is manufactured by New Generation software of Bristol and is available from W. H. Smith at £5.95.

- Getting Started 9
- Value 6
- Playability 6

### PENETRATOR

have the effect of slowing down the scrolling terrain to enable you to drop down or rise up to avoid flying into an obstacle.

Playability of Penetrator is greatly improved by a comprehensive list of game options. One or two players can play and you can choose the type of landscape you wish to negotiate with the "terrain editor".

The game stores your current high score and also enables the five top scores of the session to be entered.

Despite this, my overall impression was of a most enjoyable and addictive game. Definitely in the top five Spectrum games.

Penetrator is produced by Melbourne House software and is available from W. H. Smith at £6.95.

- Getting started 9
- Value 8
- Playability 9

## supermarket ...



## NEW SUPER SOFTWARE CLUB

### THE CLUB YOU CAN TRUST!

The best software from the most respected houses, for  
ZX81 \* SPECTRUM \* DRAGON  
\* ORIC \* ACE \* BBC

Membership includes 20% off 1st tape 15% off next 3 tapes.  
10% off all future tapes. Mail Order Membership £8.00  
Shop Membership £5.00 Optional LIFT Membership only £5.00 extra!  
PLUS: Special Offers \* Newsletter \* Free Offers \* Special Hardware Offers  
or write (enclosing S.A.E.) for details.  
Call now: 0533 29023 5 ST. PETERS LANE, LEICESTER

### DRAGON 32 or TANDY TRS-80 Colour?

Lots of programs — lots of useful hints and information EVERY single month in "RAINBOW", an exciting new 200-page magazine from U.S.A.

Send £1.95 (plus large 56p s.a.e.) for sample issue to ELKAN ELECTRONICS (Dept CVG), FREEPOST, 11 Bury New Road, Prestwich, Manchester M25 6LZ or telephone 061-798 7613 (24 hour service).

### TRS80 — VIDEO GENIE SOFTWARE LIBRARY

25 Super programmes — machine code arcade games, simulations, competitive games, adventures, dungeons & dragons, puzzles and ball games; plus a few education and Business programmes. Including Breakout, Star Wars, Amazing 3D Mazes, Gambling Machine, Corridors of Doom & Trap It. All 25 on one C48 cassette, sent by return post for only £8.95 inclusive, or send s.a.e. for full details.

SPARTAN SOFTWARE (Dept. CVG)  
9 Cotswold Terrace, Chipping Norton, Oxon.  
Tel: 0608-3059  
(Standard TRS80 and Genie computers only — not colour)

### ATARI 400/800 OWNERS

Utility now available that allows you to put up to 10 of your single load m/c tapes onto one disc. Works with most tapes. Needs 32k Ram + disk. Also available, copier that copies most single and multi-file tapes easily. Supplied on cassette £9.95 each.

Cheque/P.O. to:  
W. Enterprises, 49 Shrewley Crescent, Tile Cross, Birmingham B33 0HU.

### TERMINAL SOFTWARE

#### VIC20 GAMES CASSETTES

TVIC3 Skramble!	£7.95
TVIC4 Terminal Invaders	£5.95
TVIC5 Meteor Blaster	£5.95

NEW HOT POTATO!	
TVIC6 Gridder	£7.95
TVIC8 Get Lost	£5.95

Coming soon — Adventure Games for the 16k VIC20!

DRAGON 32 Games Cassettes	
TDRAG1 Line Up 4	£4.95

All above available at selected shops and by mail order from —  
Terminal Software, 28 Church Lane, Prestwich, Manchester M25 5AJ.

### VIC 20!! QUALITY SOFTWARE

Our catalogue is packed with tips and information, software terms, with programs of all sorts, from m/c fast action games to business and utility software. We supply cassettes (C60) at £3.80 per 10, a listing service, conversion plans for Vic 1515 printer and a lot more besides. Send SAE to:

C. P. White, 76 Uxbridge Road, Hanwell, London W7 3SU  
NO FANCY PACKAGING NO FANCY PRICE

## supermarket ...

### ATARI 400/800 OWNERS WHY BE BORED?

Cassettes and cartridges at low rental fees. Send S.A.E. for details: Scorpio Games Hire, 66 Mornington Road, London E4 7DT.

### BBC MICRO: Landfall+Serpent

**LANDFALL:** Descent simulator with full cockpit graphics. Very challenging and not for the fainthearted!

**SERPENT:** Eat or get eaten in this frantic maze game. Totally addictive.

Both on one tape (32K OS 0.1/1.0) £6.50



Cheques and POs to: GT Software  
8 Bull Street, Pottton, Sandy, Beds.

### VIC-20 SOFTWARE £4

#### VIC ASTEROIDS

100% machine code, with thrust, hyperspace, multiple bolts, double size screen, high score, etc., etc.

#### VIC INVADERS

The meanest game of Space Invaders you'll ever play. Feature packed, with double size screen, hi-res, etc.

#### ASTRO SLED

Pilot your sled through the jagged space canyon — with machine code for speed — highly addictive.

#### SPACE FIGHTER

A machine code space dogfight simulator, with hi-res etc. Centre the elusive alien in your cross-hair sights.

All programs supplied on cassette, for the unexpanded VIC-20, at £4 each (post free). Please state VIC-20 and mention Computer & Video Games when ordering.

For more information, then send an SAE by FREEPOST.

Dealer enquiries welcome.

**ARCADIA SOFTWARE,**  
FREEPOST, Swansea SA3 4ZZ.

### ATTENTION ATARI 400/800 USERS

£40 per year or £25 per ½ year allows you to loan up to 50 games of your choice from our extensive library on tape, disk or rom. Free utility tape, send large SAE to **AMUSEMENTS UNLIMITED, 49 LESLIE CRESCENT, ST. MICHAELS, TENTERDEN, KENT. TN30 6BX.**

### BBC Micro 32K

#### Escape from Orion

A superb new machine code arcade game. Your space ship has landed on a planet where you have to collect supplies. Move left, right, up, down and jump (like Donkey Kong). 4 different screens, with a large variety of hazards. Keyboard or joystick control. Lots of options. Full colour Mode 2 graphics.

Only £6.75.

#### Xanadu Adventure

The best BBC Adventure. 1 or 2 players. Over 100 locations. Very difficult. £7.75.

#### Acorn Atom 12K

SAE for details of Adventure and arcade games.

All prices inclusive.

### HOPESOFT

Hope Cottage, Winterbourne,  
Newbury, Berks RG16 8BB

# SOFTWARE SOFTWARE SOFTWARE REVIEWS

## HERE COME THE ALIENS AGAIN!

### GALAXIANS

Remember those twirling, swirling aliens Galaxians? Atari do and they've released a cartridge for the 400 and 800 full of them!

This is a most impressive copy of the arcade original. I could see no major differences between the computer game and the arcade version.

The Galaxians attack in random formation, sometimes peeling off from the uniform columns one by one, or attacking in waves of three.

As in the arcade game the yellow commander ships scream in from behind the blue drone ships and are the key to high scores. If you can pick these off you can score up to eight hundred bonus points.

To repel the Galaxians you have only three ships but you can earn a bonus ship by notching up 5,000 points. From then on you must fire accurately and quickly.

The game gets progressively difficult. The more sheets of Galaxians you blast out

of the skies the quicker and heavier their firepower.

Screen instructions report on your current score, the high score, skill level, and a red flag system records the number of screens wiped clean.

Galaxians is a tried and successfully tested arcade game. I could not fight off the tiniest twinge of boredom, however, as I blasted the umpteenth alien.

Surely a company like Atari who were big enough to market Pacman when everyone else was blasting aliens doesn't need to revert back to blasting aliens in 1983? I hope not anyway. I'm getting slightly tired of being a space ace!

Still, a good home conversion of a classic arcade game and, if you can afford it, a nice one to have in the collection. Galaxians is available from your Atari dealer now at £28.95.

- Getting started 7
- Value 7
- Playability 8

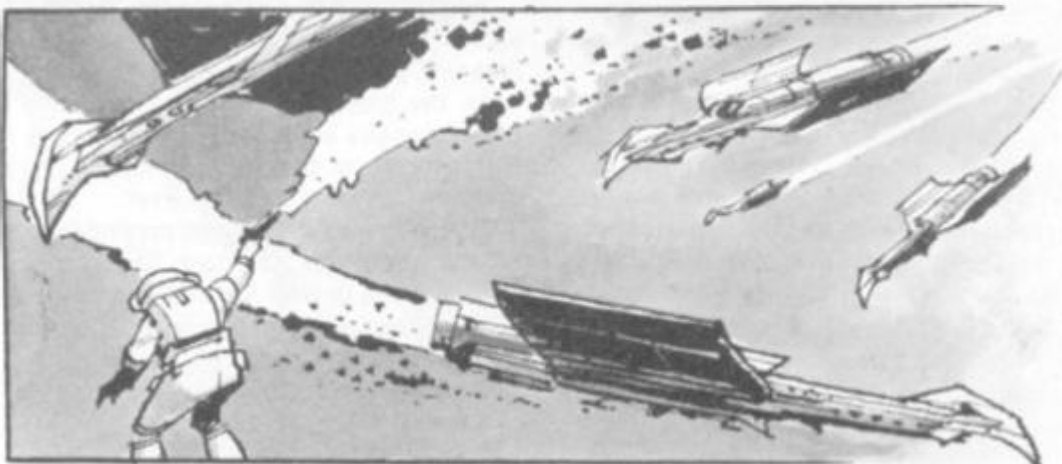

## PUT SOME STARS IN YOUR EYES ...

### STARSHIP COMMAND

There's more than a touch of Asteroids in Acornsoft's new game for the BBC Model B, Starship Command.

An impressive simulation of movement is created as the aliens scroll past your stationary ship, which is armed with impressive flight controls. Long and short range scanners tell you the positions in the galaxy of the various aliens.

You also have shields to protect you from alien torpedoes.

Your mission is to protect a planet from invading enemy spaceships. When your mission is completed the Starship Commanders will give you their comments on how they think you have performed and your worthiness for the next mission.

These comments are not always very complimentary. The best I managed was "satisfactory" and on more than one occa-

sion the Commanders told me they were "furious", "displeased", and "disappointed".

A careful eye on your energy banks is the key to promotion in the Starfleet as this will ensure a successful mission. Each starship has four energy banks which are constantly recharging.

You can score points by ramming the aliens but they are worth more if you shoot them.

As you work your way up through the ships and missions the challenges get more difficult as the aliens become faster and more accurate with their torpedoes.

The game can be played using the keyboard or joysticks and is available from Acornsoft of Cambridge at £9.95 for the BBC Model B.

- Getting started 8
- Value 8
- Playability 9

# VISION STORE

South London's  
Largest Software  
Centre

We are major stockists of software for:— Atari, Vic-20,  
Commodore 64, Dragon 32. Also software for ZX81 and BBC.

**NEW**

**Commodore 64**  
64K Colour Computer  
in Stock Now  
**£339.95**

## COMMODORE Vic-20



5K  
**£129.95**  
inc Basic

21K  
**£169.95**  
inc Basic

Vic Cassette **£44.00**  
Vic Printer **£229.00**  
Vic 1541 Disk Drive **£299.95**  
**16K RAM Pack £39.95**

(Switchable For 3K Programs)

## ATARI 400



16K  
**£159.95**  
Less Basic

48K  
**£229.95**  
Less Basic

Programmer Kit **£39.90**  
Basic Cartridge **£34.90**  
Atari 800 16K inc  
Basic **£499.00**  
Atari 800 48K **£569.00**

**Dragon 32**  
Limited stocks available  
Come in for a Demo or send  
for our list. Full range of  
Software.  
**£198.95**

**AMAZING ORIC-1**  
Colour Computer 48K  
Microsoft Basic  
**£169.95**

Over 900 software programmes  
always in stock. We carry  
probably the widest range with  
continuous demonstrations.

Mail Order/Export  
Send for our comprehensive list.

We offer excellent part exchange  
deals or cash for your old  
machine.

# VISION STORE

Vision Store, 3 Eden Walk Precinct  
Kingston-on-Thames, Surrey. Tel: 01-546 8974

All prices include VAT



Ask  
about our  
Credit  
Facilities

Prices correct at time of going to press but subject to change without  
notice

**New!**



**COLECO  
VISION**  
CBS COLECOVISION —  
**£149**

— INCREDIBLE GRAPHICS!  
EXPANDS INTO A FULL MICRO-  
COMPUTER SUPPLIED COMPLETE  
WITH DONKEY KONG!

**2 YEAR  
GUARANTEE**

ON  
**ATARI  
COMPUTERS**

WE SERVICE ALL ATARI &  
COMMODORE COMPUTERS  
SERVICE DEPT :  
061-236 3395

**ATARI  
INDEPENDENT  
SERVICE CENTRE**

FAST NATIONWIDE  
MAIL ORDER  
ON ALL  
PRODUCTS.

FULL RANGE  
OF CHESS  
COMPUTERS  
IN STOCK

**WE STOCK**

ATARI 400/800  
COMPUTERS, SINCLAIR  
(shop sales only),  
COMMODORE VIC, 64  
VECTREX COMPUTERS.

CALL FOR  
BEST  
PRICES!

**WE STOCK**

ALL ATARI, ACTIVISION,  
PARKER, APOLLO,  
IMAGIC, MATTEL &  
COLECO CARTRIDGES.

CALL FOR  
BEST  
PRICES!

**WE STOCK**

COMMODORE  
64/VIC  
SOFTWARE

CALL FOR  
BEST  
PRICES!

**WE STOCK**

LOTS AND LOTS OF ATARI  
SOFTWARE. E.g. Zaxxon,  
Nautilus, Jumbo Jet Pilot, Apple  
Panic, Centipede, Miner 2049er, Slime, Intruder, Alien  
Swarm, Preppie, Pacman, Mathpack, Choplifter Rom,  
Soccer!, Airstrike Rom — plus many, many more  
titles — Call now for our latest batch of detailed brochures!  
We will keep you up to date on all the new software  
releases!!! — Upgrade to 32K/48K today!

# GEMINI ELECTRONICS

Dept. CVG, 50 Newton St., Off Piccadilly, Manchester M1 2EA. Tel: 061-236 3083/7259

**NEW!** ATARI VCS  
COMPUTER  
KEYBOARD  
CONVERTS YOUR ATARI INTO A REAL  
COMPUTER! CALL NOW FOR DETAILS!!!



**ATARI 400 TYPEWRITER  
KEYBOARD** NOW IN STOCK AT  
CALL NOW FOR DETAILS!! **£79.95**

# ZX Spectrum JOYSTIX ! VIC 20 SOFTWARE

NEW LOW PRICE



**INTERCEPTOR  
SOFTWARE**

FROM **INTERCEPTOR  
MICRO'S**

At last, the ultimate in ZX add-ons has arrived. The unique board has been designed to take Atari\* type or Commodore\* type joystick. The board will take two joysticks+ which are software programmable using the in statement on your Spectrum. Just add a few simple lines to your programs for true arcade action. Supplied with full instructions and demonstration cassette for only

**£15.95**

**TRADE ENQUIRIES WELCOME  
FOREIGN DISTRIBUTORS REQUIRED**

## SOFTWARE FOR THE UNEXPANDED VIC 20

### FROG



**FROG**  
An amazing version of Frogger in the unexpanded VIC 20. With diving turtles and plenty of vehicles to run you down. Fast action and high resolution graphics. Joystick or Keyboard control

....£4.00

### PUCKMAN



**PUCKMAN - MACHINE CODE**  
The old favourite back again. Joystick or keyboard control. Fast action. High resolution colour graphics on the unexpanded VIC 20

....£6.00



**PENNY SLOT**  
This program is designed around a penny slot machine and gives true to life animated action. Try your luck to win a fortune. For Vic 20. With hold and nudge features for only

....£4.50



**VIC BOMBER**  
An extremely fast action Bomber game for the Vic 20. With high resolution colour graphics. Flatten the enemy city before it's too late.

....£3.00

### ALIEN ATTACK



**ALIEN ATTACK - MACHINE CODE**  
You are under attack from an immense force. This program has various ways for you to battle against giving an extra-terrestrial experience for any adventurous human being

....£6.00

### VIC RESCUE



**VIC RESCUE - MACHINE CODE**  
Your Planet is under attack by a fourth dimension and your only escape is by lunar pod to the mother ship. However you must first dodge your way through the Astroid belt and onto the landing pad before returning home. Keyboard or Joystick control, high resolution colour graphics

....£5.00

### GALAXZIONS



**GALAXZIONS - MACHINE CODE**  
This is the most amazing alien game ever seen on the VIC 20. Galaxzions swarming in attack formation to destroy your planet. The nearest program to the real arcade game for the unexpanded VIC 20

....£7.00

### SPACE BUGS



**SPACE BUGS - MACHINE CODE**  
Can you defend your planet from an alien invasion. The Marauding bugs are swarming in for the kill. So keep on your toes, joystick or keyboard

....£4.00

### WORDHANGER



**WORDHANGER**  
ATARI 400/800 16k  
A highly educational hangman game with vocabulary and 2 player or play against the computer option

....£5.00

Mr. Mrs, Miss \_\_\_\_\_  
Address \_\_\_\_\_

Quantity	Item	Unit Price	Total
	Joystix Board (Spectrum)	£15.95	
	Galaxzions Vic 20	£7.00	
	Space Bugs Vic 20	£4.00	
	Frog Vic 20	£4.00	
	Alien Attack Vic 20	£6.00	
	Bomber Vic 20	£3.00	
	Puckman Vic 20	£6.00	
	Space travel Vic 20	£5.00	
	Vic Rescue Vic 20	£5.00	
	Penny Slot Vic 20	£4.50	
	Wordhanger Atari	£5.00	
	Postage & Packing		.50P
<b>TOTAL</b>			

Send order to: Interceptor Micro's, Lindon House, Please add P&P  
The Green, Tadley, Hants CVG4 83

\* JOYSTIX SHOWN NOT INCLUDED

## STOP PRESS NEW GAMES

**CRAZY KONG**  
Unexpanded VIC 20 ONLY £6.00

**FANTAZIA**  
Unexpanded VIC 20 ONLY £6.00

**WATCH THIS SPACE**



## MAKE YOUR CONTRIBUTION TO SPECIAL EDUCATION MORE EFFECTIVE

Robyn Frankham copes very well with her learning problems, thanks to developments with computers in special education. Like many other children, she now has the ability to communicate with the aid of microelectronic devices which help her to write essays, draw pictures and most important of all, to gain her independence.

*Learning To Cope '83 — Computers in Special Education*, is the second of this annual publication which presents the story of Robyn and how many other physically and mentally handicapped children and adults are coping with their futures. Tremendous progress is being made through the manufacture of specialised devices and through the dedication of teachers and parents.

*Learning To Cope '83* looks at specialised computer hardware and software and brings you the latest developments in applications covering all aspects of special education. Read for yourself how committed people have developed and redesigned new and existing equipment to help those in special education help themselves.

We can all help if we care enough.

**Learning To Cope '83 — Computers in Special Education £2**

Please send me a copy of *Learning To Cope '83 — Computers in Special Education*. I enclose a cheque/postal order made payable to Educational Computing for £2 (including p&p).

Name \_\_\_\_\_

Position \_\_\_\_\_

Establishment \_\_\_\_\_

Address \_\_\_\_\_

Signed \_\_\_\_\_

Now please post to: *Learning To Cope '83*, 8 Herbat Hill, London EC1R 7JH.

# Salamander Software

## DRAGON 32 AND BBC MODEL B SOFTWARE

### DRAGON-TREK

£9.95  
A real time version of the classic space game featuring full colour tactical, status and long-range scanner displays, hyperprobe, the Faerie Queen, Klingons and Klingon commanders, tractor beams, enemy movement, black holes and much more. Choose from ten levels of difficulty and three sizes of galaxy. Comes complete with 16-page flight manual. JOYSTICK (1) REQUIRED. Dragon Data Approved.

### WIZARD WAR

£7.95  
A game of magical combat between the Wizards of the Tri-Suns for supremacy of the planet Xarg. Both dexterity and deduction are needed in order to outwit your opponent as spell is traded against spell. Comes complete with 12-page illustrated spell book. JOYSTICKS (2) REQUIRED. Dragon Data Approved.

### GOLF

£7.95  
An accurate interpretation of the game of golf written by a keen club player. Allows match play between two players or one player may play using the Stableford points system widely used for competition golf. Features full club selection, hazards, out of bounds and player handicaps. Dragon Data Approved.

### GRAND PRIX

£7.95  
Do you have the potential to be a champion Formula 1 driver? Find out when you race on these 8 famous Grand Prix tracks from around the world. For 1 or 2 players. 2 joysticks required. Dragon Data Approved.

### GAMES COMPENDIUM D1

£7.95  
Six great games for the whole family — Donkey Derby, Blackjack, Kingdom, Hunt the Wumpus, Noughts and Crosses and Lunar Lander. Dragon Data Approved.

### VULCAN NOUGHTS AND CROSSES

£7.95  
A three-dimensional game of noughts and crosses for one or two players. Also includes a zero player option where the machine plays itself. Can you out-think your Dragon? Dragon Data Approved.

### THE EDG GRAPHICS PACKAGE £24.95

#### For the BBC Model B Microcomputer

An advanced picture drawing system developed by a firm of consulting engineers to the oil and utility industries worldwide. Uses cassette tapes for software and picture storage and is controlled entirely by normal keyboard input — no extra hardware required. The main system features are:

- ★ Picture drawing in mode 0, 1 or 2.
- ★ Actual and Logical colour changes at any time.
- ★ Drawing functions:  
Lines, boxes, circles, arcs, text, shape repetition.
- ★ Drawing aids:  
Grid, elastic band, save and home cursor (5 positions).
- ★ Colour fill.
- ★ Text window showing x, y cursor position, length, angle, colour menu and current colour.
- ★ Saving and Loading of picture using cassette tapes.
- ★ Multi-file pictures facilitating very complex drawings.
- ★ Flashing cross-hairs cursor.
- ★ User instructions/prompts.

This package comes complete with a spiral bound manual.

SEND SAE FOR CATALOGUE OF OUR FULL RANGE OF DRAGON AND BBC MODEL B SOFTWARE

Cheques or postal orders payable to Salamander Software, 27 Ditchling Rise, Brighton, East Sussex BN1 4QL.

Tel: 0273 771942

PLEASE ADD 50p P&P TO ALL ORDERS

Programmers wanted: good royalties paid! Trade enquiries welcome.



# Make Friday your



★ **Personal Computer News** is weekly, published every Friday.

★ **Personal Computer News** is only 35p.

Around a hundred pages printed on glossy paper, much of it in full colour.

Probably the best value to be found on your newsagents shelves.

★ **Personal Computer News** is edited by the largest editorial team working on any

microcomputer publication in Britain. We have individual editors working on hardware, software, peripherals, features, listings and programs – fourteen of them in all.

A massive investment of talent and expertise with only one aim. To make **PCN** the finest microcomputing title in Europe.

★ Our deadlines on news and features are short.

That means we get to publish comprehensive hardware tests, software reviews, news and much else besides, weeks and weeks before monthly titles

# Our day of discovery.



can hope to do so.

**Personal Computer News** is carrying scoop reviews and tests in virtually every issue.

Whatever your particular interest in the world of microcomputing, you'll find it first in **PCN**.

★ **Personal Computer News** comes from the publishers of **Personal Computer World**.

That means you can rest assured on the quality and independence of the editorial package.

★ Every issue of **Personal Computer News**

carries a pull out 'part-work' which will gradually build into a comprehensive library on microcomputing.

In addition, you'll find free Readers' Buy and Sell ads, a totally unique programs listing section for the more popular micros, Buyers' Guides, language articles and much, much more.

★ Make Friday your day of discovery. Try **Personal Computer News**. The Complete Computing Weekly.

# THE PROGRAM THAT'S LEAPS AHEAD OF ALL THE REST...

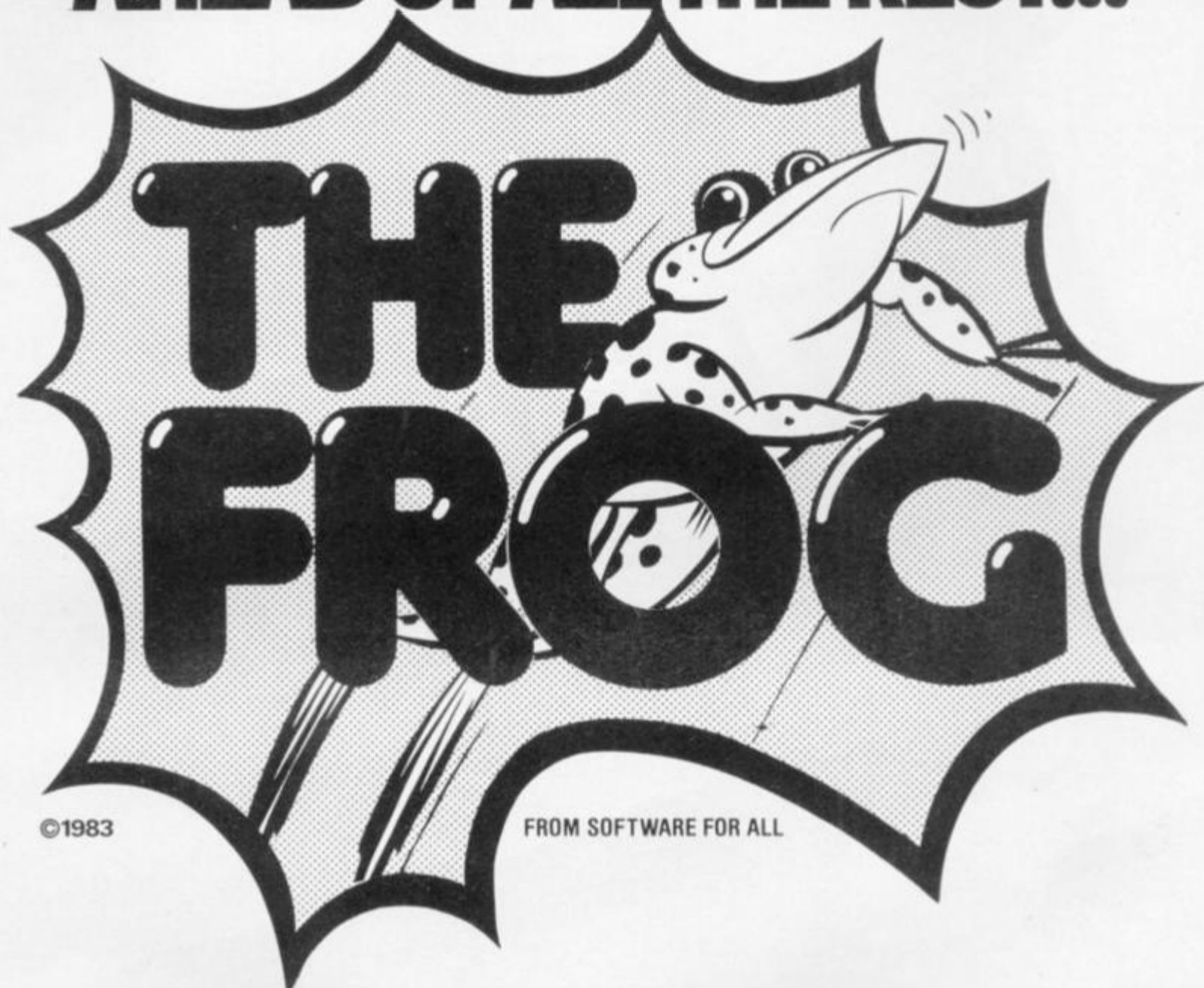

©1983

FROM SOFTWARE FOR ALL

## THE MOST FANTASTIC ACTION GAME FOR THE BBC MICRO!

FAST ARCADE PLAY!  
MODE 2 COLOUR GRAPHICS  
AT ITS BEST!  
FIVE TUNES!  
INCREDIBLY ADDICTIVE!

AVAILABLE NOW  
AT YOUR SOFTWARE  
FOR ALL DEALER

# ONLY £8.95

### SEE IT NOW AT YOUR NEAREST SOFTWARE FOR ALL DEALER!

#### A B & C COMPUTERS

11 Brockstone Road  
St. Austell  
Cornwall PL25 3DW  
Tel: 0726 64463

#### BLADEN COMPUTER SYSTEMS

22 Glynne Street  
Farnworth, Bolton  
Lancs BL4 4DY  
Tel: 0204 794226

#### BYTEWARE LTD.

Unit 25  
Handyside Arcade  
Newcastle On Tyne  
Tel: 0632 617111

#### CARLTON COMPUTERS LTD.

4 Swanstons Road  
G1 Yarmouth  
Norfolk NR30 3NQ  
Tel: 0493 58898

#### COMPUTERS FOR ALL

72 North Street  
Romford, Essex  
Tel: 0708 752862

#### COMPUTER PLUS

47 Queens Road  
Watford  
Herts WD1 2LH  
Tel: 0923 33927

#### ESSEX COMPUTER CENTRE LTD.

150 Moulsham Street  
Chelmsford, Essex  
Tel: 0245 358702/87969

#### FAREHAM COMPUTER CENTRE

56 High Street  
Fareham, Hants  
Tel: 0329 239191

#### GAMES WORKSHOP

1 Dalling Road  
Hammersmith, London W6  
Tel: 01-741 3445

#### GAMES WORKSHOP

162 Marsden Way  
Arndale Centre  
Manchester  
Tel: 061-832 6863

#### GAMES WORKSHOP

Unit 37  
Birmingham Shopping Centre  
Birmingham B2  
Tel: 021-632 4804

#### GAMES WORKSHOP

95 The Moor, Sheffield  
Tel: 0742 750114

#### MANSFIELD COMPUTERS & ELEC

79 Ratcliffe Gate Mansfield  
Notts, NG18 2JB  
Tel: 0623 31202

#### MICROSTYLE

29 Belvedere  
Lansdown Road, Bath  
Tel: 0225 319705

#### RAM ELECTRONICS

106 Fleet Road  
Fleet, Hants, GU13 8PA  
Tel: 02514 5858

#### RDS ELECTRICAL LTD.

157-161 Kingston Road  
Portsmouth  
Hants PO2 7EF  
Tel: 0705 812478

#### R. M. K. ELECTRONICS LTD.

Hinton House, Station Road  
New Milton  
Hants, BH23 6HZ  
Tel: 0425 616110

#### STORKROSE LTD.

44 Shroton Street  
London NW1  
Tel: 01-258 0409

#### SUPERIOR SYSTEMS LTD.

178 West Street  
Sheffield  
South Yorkshire, S1 4ET  
Tel: 0742 755005

#### TECHNOMATIC LTD.

17 Burnley Road  
London NW10  
Tel: 01-450 1500

#### WATFORD ELECTRONICS

33-35 Cardiff Road  
Watford  
Herts WD1 8ED  
Tel: 0923 40588

Distributor for Holland,  
Belgium & Luxembourg:

#### AACKOSOFT

Postbus 3111  
2301 DC Leiden  
Tel: 01880 11446

**SOFTWARE  
FOR ALL**  
*"Programs for the people"*



# For Vic-20, Atari, Texas Instruments & Sinclair

## missile-panic

TRAPPED IN THE MAZE OF DEATH THE VENOMOUS MISSILE IS ON YOUR PATH. THERE'S NO HIDING.

A High Speed, Nerve racking Arcade Game for the Unexpanded VIC

Just £6 inclusive



### ROAD RUNNER £5

In this remarkable game you must control the Road Runner through the space world of vehicle mayhem... and battle into the gravity space lanes. With ever increasing levels of play, a super cool level is needed to conquer this difficult machine code game.

### SPACE HOPPER £5

Once there was invaders, then Packmen, now there's Space Hopper. Can you guide your Space Frog through the twister and tangle of space traffic, without being crushed by intergalactic space trains? Can you avoid being shot by hidden laser guns and are you able to hop through the space warp? If you think you can, enter it today!

### ANDROID ATTACK £5

The Androids of Jupiter can even growling faces are on your path in the maze of the lost hole. They look more menacing as each second passes and will attack without mercy. Run to stay alive!

FOR THE UNEXPANDED VIC-20

Just £6 inclusive

ATARI 400/800(16k)

SENSIBLY PRICED ATARI SOFTWARE NOW AVAILABLE FROM TITAN

## CAVERNS



Enter the world of space adventure with the totally addictive arcade game that will take a long time to outgrow, and one that does not cost the earth. Navigate your spacecraft through rock caverns, past laser fields, through rock valleys and into the unknown. You will have to see it to believe it! Supplied on cassette with full instructions.

Just £6 inclusive

## MISSION 99

ATARI 400/800(16k)



THERE'S TERROR IN THE STREETS, MANHATTAN IS UNDER ATTACK. YOU'RE THE ENEMY, DON'T MISS IT. Supplied on Cassette with full instructions for the standard £199.95.

## GROUND FORCE

Just £5 inclusive

Sinclair ZX Spectrum



The Ground Forces have been destroyed so the air attack must begin and you're in control! A Superb Arcade Game for the 8K or 4K Spectrum

## Jupiter ACE Goes Forth...

ACE INVASION Only £5 inclusive

The name says it all, Invaders as you've never seen them before. A fast action arcade game for the sensational (unexpanded) Jupiter Ace

## TITAN PROGRAMS

THE COMPUTER PALACE, 46 MARKET PLACE CHIPPENHAM, WILTSHIRE SN15 3HU ENGLAND

### IMMEDIATE DELIVERY

Please send me:  
 I enclose cheque/P.O. for £ \_\_\_\_\_  
 Barclaycard No. \_\_\_\_\_  
 Name \_\_\_\_\_  
 Address \_\_\_\_\_  
 Post Code \_\_\_\_\_  
 (All Please send my Access No. \_\_\_\_\_)  
 Expiry Date \_\_\_\_\_  
 Order Discount Available  
 ACCESS, BARCLAYCARD ORDERS WELCOME (On 24hr)  
 ANSWERPHONE 0286 80024 or mail to  
 TITAN PROGRAMS, THE COMPUTER PALACE,  
 46 MARKET PLACE, CHIPPENHAM, WILTSHIRE, SN15 3HU

## ELECTRONEQUIP

(Authorised BBC Dealer and Service Centre)

BBC1	BBC Micro Model A	299.00
BBC2	BBC Micro Model B	399.00
BBC3	BBC Model A Micro with 32K	333.50
BBC4	BBC Model A Micro 32K & VIA	339.50
BBC21	Upgrade Model A to B	99.82
BBC27	Disc Upgrade for BBC B	109.25
BBC30	14" Colour Monitor for BBC	286.25
BBC33	BMC12A 12" Black/Green Monitor	90.85
BBC36	14" Monitor/TV 80 columns	244.95
BBC40	Cassette Recorder for BBC	29.90
BBC41	Single 5.25" Disc Drive 100K	265.00
BBC42	Dual 5.25" Disc Drive for BBC	447.00
BBC45	New improved Cassette for BBC	35.88
BBC48	Dual 800K low profile disc drives	897.00
BBC49	5.25" Discs for BBC 40/80 tracks	2.20
BBC50	Epson MX80T type 3 for BBC	373.75
BBC54	Daisy Wheel printer for BBC	558.90
BBC70	Plinth/Stowage for BBC	29.90

Large stocks. Prices inclusive of VAT.  
 All prices inclusive of postage except micros £3  
 Access and Barclaycard welcome.

## Electronequip

36-38 West Street, Fareham, Hants. PO16 0JW.  
 Tel: 0329 230670



## New Generation Software

From M. E. Evans the author of the highly acclaimed 3D MONSTER MAZE and 3D DEFENDER



3D TUNNEL (16K & 48K Versions on one tape)  
 What lies in the depths of the tunnel? Flapping bats, leaping toads, scurrying rats, crawling spiders, all appear live in the 3D TUNNEL as it weaves about. We leave the last object to your imagination. (Not in 16K version)  
 Price £5.95, special introductory offer at £4.95 until February 28th.

TWO GAMES FOR THE SPECTRUM



ESCAPE (requires only 16K)  
 Can you escape from the dinosaur infested maze? 3D grandstand view provides dinosaurs with the opportunity to hide behind the hedges or to soar over them to swoop down on you. "One of the best and most original games we have seen for the Spectrum so far". SINCLAIR USER. Price £4.95

For instant CREDIT CARD Sales by phone only ring 01-930-9232

Orders to: NEW GENERATION SOFTWARE dept CV9  
 FREEPOST (BS 3433) (no stamp required in UK)  
 OLDLAND COMMON, BRISTOL BS15 6BR

Please send s.a.e. with all enquires and for lists of stock-ists. TRADE ENQUIRIES WELCOME AT ADDRESS ABOVE.

**INTEREST  
FREE  
CREDIT  
NOW! ON:-**

# Atari, VIC 20, and Dragon

If your order contains over £120 worth of computer hardware apply now for interest free credit by telephoning: Mail-order: (0702) 552911. London Shop: 01-748 0926. Birmingham Shop: 021-356 7292. Southend Shop: 0702 554000 or write to P.O. Box 3, Rayleigh, Essex SS6 8LR.

You pay 10% down, then 10% per month for a further nine months (to nearest penny). Example: Atari 400 48K. Cash price £299. Credit terms: £29.90 down, then £29.90 per month for nine months. Total £299. Credit quotations on request. This offer subject to approval which can take up to 48 hours (APR = 0%).

## THE NEW COMMODORE 64

The incredible new computer from Commodore comes with 64K RAM fitted! Plus 16 colours hi-res graphics, 320 x 200 pixels, 40 columns by 25 lines, Z80 micro processor can be added — that means you can run CP/M software, 8 independently movable Sprites with collision detection, and a sound generator with 3 voices, 4 wave-forms, envelope and filter to rival some dedicated music synthesisers. And all this at the most incredible price ever. (AF56L) Only £339.00

## DRAGON 32

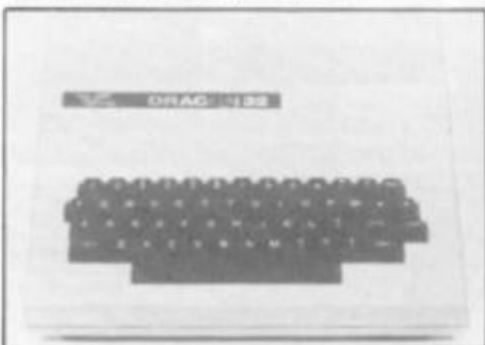

The amazing new British computer with a full-travel standard keyboard, a 16-bit microprocessor, 32K RAM fitted (expandable to 64K and later to 256K!), 9 colours, hi-res graphics and Microsoft extended colour BASIC (the very best BASIC to learn with). It can be used with virtually any ordinary cassette recorder, it has a printer interface (Centronics-type), joysticks are available and it's incredible value for money. (AF57M) Only £199.50.

Lots of new Dragon software available.

## THE AMAZING ATARI COMPUTERS

**4 Consoles Available:**  
Atari 400, 16K RAM (AF36P) £199.95  
Atari 400, 48K RAM (AF37S) £249.00  
Atari 800, 16K RAM (AF02C) £399.00  
Atari 800, 48K RAM (AF55K) £440.00

\*All above with BASIC & handbooks  
Carriage free, delivery next day  
by Datapost

Other hardware:  
Cassette Recorder (AF28F) £50.00  
Disk Drive (AF06G) £299.95  
Thermal Printer (AF04E) £199.95  
Epson MX80T Mk III (AF38R) £399.95  
Epson MX80F/T Mk III (AF40T) £447.35  
Printer Interface for 400 (AF41U) £59.95  
Printer Interface for 800 (AF42V) £59.95  
Interface Module (AF29G) £135.00  
Versawriter (AF43W) £199.95  
16K RAM Module (AF08J) £55.00  
48K RAM Module for 400 (AF44X) £99.95  
48K Upgrade for 400 (AF45Y) £75.00  
Floppy Disk (YX87U) £2.50  
Le Stick (AC45Y) £24.95  
Joystick Controllers (Pair) (AC37S) £13.95  
Paddle Controllers (Pair) (AC30H) £13.95

For full details ask for our hardware leaflet (XH54J) SAE appreciated

### JOIN THE U.K. ATARI COMPUTER OWNERS' CLUB

An independent users' group. Four issues of the club magazine for only £3.00! Address your subscription to Ron, Issue 1 of the club magazine featured a tutorial on character set redefinition and contained a collection of demonstration and games programs and lots more. Issue 2 featured a tutorial on player/missile graphics, an article about graphics on computers, a selection of members' contributions to the program library and much more.



## THE FINEST SELECTION OF ATARI SOFTWARE

<b>Teach Yourself Programs</b>	Atari Word Processor	Dr Goodcode's Cavern	Golden Voyage
Conversational French -5C-16K-YG44X £39.95	Text Wizard -1D-32K-8G99H £75.00	Escape From Vulcan's Isle -1D-40K-K830H £20.75	Treasure Quest -1C-16K-K836P £10.95
Conversational German -5C-16K-YG45Y £39.95	Mini Word Processor -1C-32K-8G98J £14.50	Zork I -1D-32K-8G94C £29.95	Software Adventure -1D-40K-K8338 £20.64
Conversational Spanish -5C-16K-YG46A £39.95	File It 2 -1D-48K-8G10L £33.87	Zork II -1D-32K-8G98D £29.95	Deadline -2D-32K-8G96E £37.25
Conversational Italian -5C-16K-YG47B £39.95	Filemanager 800 -1D-40K-8G98P £75.00	Zork III -1D-32K-K831J £29.95	Sierocross -1D-32K-K837S £29.95
Touch Typing -2C-16K-YG48D £19.95	Graph-It -2C-16K-YG51F £14.95	All Babi & The 40 Thieves -1D-32K-8G78K £25.93	Energy Car -1C-16K-YG53H £14.95
Status & Capitals -1C-16K-YG56L £14.95	Statistics -1C-16K-YG52G £14.95	Temple Of Agocha (Part 1) -1C-32K-8G85G £27.45	Kingdom -1C-8K-YG55K £14.95
Euro Countries & Capitals -1C-16K-YG57M £14.95	Montage & Loan Analysis -1C-16K-8G86W £14.95	Upper Realities (Part 2) -1C-32K-8G87U £13.80	Speech Shuttle Module 1 -1D-32K-8G65V £18.95
Kids 1 (3 Programs) -1C-16K-8G00A £11.75	Bob's Business -1C-32K-8G11M £10.59	Curse Of Ra (Part 3) -1C-32K-8G89W £13.80	<b>War Games</b>
Kids 2 (3 Programs) -1C-16K-8G02C £11.75	<b>Adventure Games</b>	Dragon's Eye -1D-40K-K832K £20.75	The Shattered Alliance -1D-48K-8G98G £28.95
Kids 3 (3 Programs) -1C-16K-8G02C £11.75	Galactic Empire -1C-32K-8G14Q £14.50	Crypt Of The Undead -1D-40K-K833L £20.75	Legionnaire -1C-16K-K800A £25.95
My First Alphabet -1D-32K-K823A £29.95	Galactic Trader -1C-32K-K825C £14.50	Empire Of The Overlord -1C-40K-8G73Q £21.95	The Battle Of Shish -1C-40K-8G83T £28.95
<b>Learn Programming</b>	Galaxy -1C-16K-8G75S £14.95	King Arthur's Hero -1C-16K-K897J £20.75	Dragon River Line -1C-48K-8G71H £18.95
Initiation To Programming 1 -1C-8K-YG42V £19.95	Relieve At Regal -1C-32K-8G21X £20.75	Lords Of Karma -1C-40K-8G79L £14.95	Tankies -1C-24K-8G938 £17.45
Initiation To Programming 2 -2C-8K-8G67X £22.95	Dationsions of Ren -1C-32K-8G248 £27.45	Nightmare -1D-40K-K835Q £20.75	Nth Atlantic Convoy Raider -1C-16K-8G83E £11.95
Initiation To Programming 3 -2C-8K-8G68Y £22.95	Star Warrior -1C-32K-8G298 £27.45	Analog Adventure -1D-32K-8G33L £16.95	Midway Campaign -1C-32K-8G81C £11.95
Basics of Animation -1C-16K-8G57M £14.50	Voyager I -1C-32K-8G348 £27.45	Pirate Adventure -1C-24K-8G30A £17.95	Battle For Normandy -1C-32K-K838P £28.95
Player Missile Graphics -1C-32K-8G59P £21.25	Invasion Orion -1C-32K-8G35A £17.25	Mission Impossible -1C-24K-8G318 £17.95	Tigers In The Snow -1C-40K-K8018 £28.95
Display Lists -1C-16K-8G51F £14.50	GFS Sierocross -1C-48K-K836D £21.95	Voodoo Castle -1C-24K-8G33C £17.95	War -1C-32K-K840T £17.95
Horizontal Scrolling -1C-16K-8G53H £14.50	Planet Miners -1C-24K-8G89W £11.95	The Court -1C-24K-8G34E £17.95	*B1 Nuclear Bomber -1C-16K-8G88Y £11.95
Page Flipping -1C-16K-8G55K £14.50	Star Flight -1D-40K-8G36D £14.95	Strange Odyssey -1C-24K-8G35F £17.95	Nukewar -1C-16K-8G87U £11.95
Sound Effects -1C-16K-8G57M £14.50	Journey To The Planets -1C-32K-K828P £20.45	Mystery Fun House -1C-24K-8G36E £17.95	Conflict 2500 -1C-32K-8G85G £11.95
Soundtracks & Music -1C-16K-8G59P £14.50	Crash, Crumble & Clomp -1C-32K-8G83E £20.75	Pyramid Of Doom -1C-24K-8G37H £17.95	Cytron Masters -1C-32K-K841U £28.95
Tricky Tutorials First & Page 6 -3C-32K-8G06G £69.95	Mission Asteroid -1D-40K-8G81Y £17.19	Ghost Town -1C-24K-8G38E £17.95	<b>Arcade Games</b>
Business Programs	Wizard & The Princess -1D-40K-8G25C £21.79	Savage Island I -1C-24K-8G09K £17.95	Star Racers -1E-8K-YG65W £29.95
Vivacalc -1D-32K-YL39N £119.95	Ulysses & Golden Fleeces -2D-40K-8G82A £20.64	Savage Island II -1C-24K-8G10L £17.95	Chopfifer -1E-16K-K887U £24.95



# \* 32K RAM PACK for the VIC 20 \*

only **£69-95**, the most versatile ram pack for the Vic 20.

Switchable to 3K, 16K, 24K plus ram 1, 2, 3 or Block 5 for machine code or data statements.

Also 3K ram pack £19.95, 8K ram pack £29.95, 16K ram pack £44.95, 4 slot Mother Board £24.95. All items slot directly into the back of your Vic 20. All prices include V.A.T.

We stock software by Audiogenic, Commodore, Rabbit, P.C.S., Computer Room, Hi-Tech, Llamasoft, Interceptor, Romik and Bug Byte. Send S.A.E. for full list.

Please send the following:

Qty.	32K ram pack @ £69.95 each
	16K ram pack @ £44.95 each
	8K ram pack @ £29.95 each
	3K ram pack @ £19.95 each
	Mother Board @ £24.95 each

PLUS £1.00 post & packaging per order

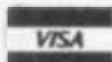

To **Ram Electronics (Fleet) Ltd,**  
106, Fleet Road, Fleet, Hants GU13 8PA.  
(02514) 5858

I enclose P.O. or cheque total £ \_\_\_\_\_

charge my ACCESS or BARCLAYCARD

Account No \_\_\_\_\_

Name \_\_\_\_\_

Address \_\_\_\_\_

CVG0483

**NEW** **THE GREATEST PROGRAMMING AID SINCE FINGERS**  
Cuts Down Program Entry Time

- How many hours do you spend de-bugging programs?
- How many times have you traced a bug to a typing error?
- How many times have you wished for another pair of hands to keep your place in program listings?
- How many times have you had back-ache, neck-ache and eye-strain through copying listings at uncomfortable angles?



**THE EASIREADER FROM BUGBEAR**  
Saves Hours in De-bugging time

- Over 99% of bugs in programs copied from printout listings are the result of entry errors — errors anyone with only one pair of hands can make. Even one mistake can take hours to trace.

**The EASIREADER Minimises Bugs by Minimising Entry Errors**

- The attractive perspex stand can be positioned where most comfortable, avoiding stiff necks and aching backs... strain causes mistakes!
- The specially designed cursor prevents skipping between complicated and similar-looking lines while allowing you to 'read through' simple lines.
- The **EASIREADER** keeps your place for two-handed keyboard entries, i.e. when using a Sinclair computer or just using the 'shift' key.
- It will even scan the off-horizontal listings found in many magazines.
- The **EASIREADER** can handle all normal magazines up to A4 size, single sheets, computer printouts and most books.

**HELP BANISH BUGS**  
Make your programming easier and more comfortable.  
**SAVE TIME AND EFFORT - AVOID FRUSTRATION**

Send for your **EASIREADER** now at a special introductory price of **£12.99**. Please add £1.25 p&p.

**BUGBEAR, DEPT. V3, NICHOLSON BUILDINGS, TEMPLETOWN, SOUTH SHIELDS, TYNE & WEAR NE33 5RZ.**



© BUGBEAR 1982 Patent Pending No. 8232718

## PALANTIR PROGRAMS LTD

**FANTASTIC PROGRAM OFFERS**

**SPECTRUM, ZX81 BBC, SHARP MZ80-K, VIC 20.**

**SPECTREK.** For the 48K Spectrum. A real-time adventure in deep space. Destroy the Klingons with the help of the on-board computer. **£5.00**

**GEOGRAPHIC.** Test your child's geography skills with these 6 programs for the 5K VIC20. Europe, South America, Gt. Britain, World Continents and Oceans, Australia & North America. All 6 on 1 cassette for only £7.95.

**DEATH STAR ATTACK** and memory match for the 16K ZX81 2 programs on 1 cassette. One a test of speed & skill, the other a test of memory. **£5.00.**

**MUSIC COMPOSER.** For the BBC Model B. Compose your own tunes and store them on cassette for later use. **£7.95.**

**SHARP SELECTION.** 6 programs for the MZ80-K Mastermind, Fox & Hounds, Noughts & Crosses, Pontoon, Hangman & Surround. All 6 on 1 cassette for only £9.95.

**ALL prices inclusive of V.A.T. & P&P. Send cheque/P.O. to: PALANTIR PROGRAMS LTD, BROCKHAM, HYDE LANE, DANBURY, ESSEX.**

A TOTALLY NEW AND ORIGINAL GAME  
FROM SOFTWARE FARM  
FOR 16K ZX81

**NEW!**

# the Super Scramble

## YOUR MISSION

To penetrate the Witches Defences, Enter her Cavern and Destroy her wicked Heart

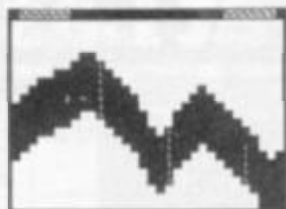

## THE WITCHES DEFENCES

**STALAGMITES AND STALACTITES** which grow across your path. Blast a way through with your Lazer Cannon (but beware — a surprise is in store for you!).

**VOLCANOES** to get past alive — if you can! — an ever increasing amount of white-hot Larva to avoid the closer you get to the witches cavern.

**VAMPIRE BATS** that cling to your ship, making your controls sluggish and finally (if you are not careful) dragging you down to your destruction.

**CAVE-INS** should you hit the side of the cave with your Lazer Cannon or Bomb, part of the roof will cave-in on you — the greater the landslides to avoid each time!

**THE NEARER** you get to the Witches Cavern, the more of her Defences she will throw at you at once. Should you survive all of them (highly unlikely) then you must contend with the Witch herself! Avoid being turned to stone by her spells while attempting to destroy her wicked Heart!

- \* 1 or 2 Players
- \* Mystery Score positions to bomb
- \* 5 Skill Levels

\* Written entirely in Machine Code  
\* Hall of Fame

DESTINED TO BECOME A CLASSIC!

AND ONLY £5.95

THE SOFTWARE FARM, DEPT CG,



CRAIGO FARM, BOTANY BAY, TINTERN, GWENT



# THE Midland Computer Fair

Personal computers  
Home computing  
Small business systems

**BINGLEY HALL, BIRMINGHAM**

**28-30 APRIL 1983** Thurs & Fri 10am - 6pm  
Saturday 10am - 5pm

Presented by **YOUR Practical** **COMPUTER Computing**

This event is the first of its kind in the Midlands, and gives you the opportunity to see and compare the enormous range of personal and home computers, small business systems, micro-computers, software packages, cassettes and scores of the very latest computer games — try them for yourself — decide how much, or how little it takes to build up your own personal computer system.

## HOW TO GET THERE

**BY RAIL** Concessionary rail fares are available direct to New Street Station. Further details are available from, British Rail Travel Centre, New Street Station, Birmingham B2 2QA Tel: 021 643 2711.

**BY BUS** every few minutes from New Street, Corporation Street, Colmore Row and Bull Ring.

**BY CAR** Bingley Hall is situated close to the city centre and is within easy access to the M1, M5 and M6. Bingley Hall will be road signed by the AA.

**Admission prices** — Adults £2.00 Children under 16 and O.A.P.'s £1.00. Party Booking: For groups of over 20 people — adults £1.50 children 75p, (plus a free ticket per 20 sold for the organiser or teacher).

For further information contact:  
The Exhibition Manager,  
Midland Computer Fair,  
Reed Exhibitions,  
Surrey House,  
Throwley Way,  
Sutton, Surrey.  
Tel: 01-643 8040



# SF GOBBLERS

PUCKMAN FOR 16K ZX81

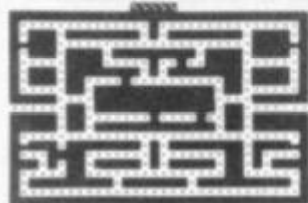

BEAT THAT HIGH SCORE!  
GOBBLE THOSE DOTS  
BEFORE THOSE MEANIES  
GOBBLE YOU! YOUR ONLY  
AIDES ARE FOUR "POWER  
PILLS" WHICH MAKE THE  
MEANIES EDIBLE. BUT  
NOT FOR LONG!

- MACHINE CODED FOR FAST ACTION
- EXTRA "GOBBLER" FOR 10,000 POINTS
- ON SCREEN SCORING
- HIGH SCORE WITH "ENTER NAME" FACILITY
- UP TO 4 PLAYERS

AN ANNOYINGLY FRUSTRATING GAME! FOR ONLY £5.95

# SF ASTEROIDS FOR 16K ZX81

STAY ALIVE AS LONG AS POSSIBLE IN OPEN SPACE FILLED WITH FLYING ROCKS. SCORE BY SHOOTING THEM — WHICH ALSO CAUSES THEM TO BREAK INTO LOTS OF LITTLE BITS AND MAKES LIFE EVEN WORSE!

- MACHINE CODED FOR FAST ACTION
- ON SCREEN SCORING
- HIGH SCORE WITH "ENTER NAME" FACILITY
- UP TO 4 PLAYERS
- EXTRA SHIP FOR 1,000 PTS (NOT AS EASY AS IT SOUNDS!)
- SHIP MOVES JUST LIKE ARCADE VERSION
- ROTATE LEFT/ROTATE RIGHT/THRUST
- FIRES IN ALL 8 DIRECTIONS
- INCREASING NUMBER OF ASTEROIDS
- THREE ASTEROID SIZES
- "NASTY" ALIEN SPACE-SHIP (FIRES BACK!)

THIS GAME IS JUST AS BAD! — AND ONLY £5.95

AN OFFER FOR REAL MASOCHISTS — BOTH TAPES FOR £9.95

MAIL ORDER ONLY—PLEASE MAKE CHEQUE/PO PAYABLE TO

THE SOFTWARE FARM, DEPT CG,



CRAIGO FARM, BOTANY BAY, TINTERN, GWENT



# Micropoint

## at Laskys



**VIC 20.**  
An ideal home computer. 5K memory. Has full colour and sound generator. Good graphics. A wide range of programs are available. **£129.90**

**ATARI AM800.**  
A home computer with a full sized keyboard. Big 48K memory. Very good graphics with full colour and sound generator. A very wide range of programs are available.

**£399.00**

A full range of peripherals, including disk drives, memory expansion units, cassette storage units and joysticks is also available.

**LYNX.**  
Compact unit with full size keyboard. Powerful 48K memory. Full colour and sound capability. Excellent graphics. Compatible with most cassette players. **£225.00**

Note: All three models shown need a separate TV or monitor. Micropoint has a complete range of suitable models from £59.90 (B/W) or £199.90 (Colour).

# The magic of the microcomputer without the mystery.

Everything you've ever wanted to know- or learn- about microcomputers is now at Micropoint. In all branches of Laskys. Micropoint has all you need to make up your mind about microcomputers. You'll find a wide choice of models- and you can test play them all, comparing each model with the next. It has experts who will explain micros to you, in language you can understand. Micropoint has a big selection of programs- they will

really make your micro magic. But you get even more than machines and advice, you get good value too. At Micropoint we keep our prices low by buying in volume and we'll also help you to buy with Interest Free Credit\* available on purchases over £250 or more; you could walk into Micropoint, choose your micro and take it away with you! You also get the famous Laskys Commitment, possibly the best after-sales package ever offered, with a 14

day exchange period, a 2-year free guarantee† and service by Laskys own network of specialist engineers. If you're already into micros and looking for something new, or better, then Micropoint is the place to find it. Come in and see for yourself. Micropoint opens up to the whole family the fascinating, educational, fun world of micro-computers.

<b>Shark Attack</b> VIC format. <b>£9.90</b> 	<b>Space Attack</b> VIC format. <b>£9.90</b> 	<b>Figure Fun</b> Atari format. <b>£14.90</b> 	<h1>JUST IN!</h1>
<b>Space Fortress</b> VIC format. <b>£9.90</b> 	<b>Multi-Sound Synthesizer</b> VIC format. <b>£9.90</b> 	<b>Super Cubes/Slip</b> Atari format. <b>£14.90</b> 	
<b>Panic</b> VIC format. <b>£6.90</b> 	<b>Skramble</b> VIC format. <b>£9.90</b> 	<b>VIC Music Composer</b> VIC format. <b>£23.90</b> 	
<b>Asteroids</b> VIC format. <b>£6.90</b> 	<b>Frogger</b> VIC format. <b>£9.90</b> 	<b>Darts</b> Atari format. <b>£19.90</b> 	
<b>Another Vic in the Wall</b> VIC format. <b>£6.90</b> 	<b>Jumbo Jet Pilot</b> Atari format. <b>£34.90</b> 	<b>Kickback</b> Atari format. <b>£28.90</b> 	
			<b>PREPPIE</b> cassette <b>£21.90</b>
			<b>SEADRAGON</b> cassette <b>£24.90</b>
			<b>STRATOS</b> cassette <b>£24.90</b>
			<b>ESCFTRAAM</b> cassette <b>£17.90</b>
			<b>BAJA BUGGYS</b> cassette <b>£21.90</b>
			<b>CHOPLIFTER</b> cartridge <b>£29.90</b>
			<b>ASTROCHASE</b> cassette <b>£21.90</b>
			<b>MOONBASE 10</b> cassette <b>£21.90</b>
			<b>LEGIONAIRE</b> cassette <b>£26.90</b>
			<b>MINER 2049</b> cartridge <b>£34.90</b>
			<b>GORF</b> cartridge <b>£29.90</b>
			<b>ZAXXON</b> cassette <b>£29.90</b>
			<b>PICNICPARA</b> cartridge <b>£29.90</b>
			<b>CLAIM JUMP</b> cartridge <b>£29.90</b>
			<b>PROTECTOR 2</b> cartridge <b>£29.90</b>

# It's the programs that make micros magic.

It means you can use it for games and for learning (anything from simple programming to a foreign language).

You can use it in the home for everything from household budgets to planning a touring holiday abroad or remembering

birthdays and important anniversaries. And if you run your own business then a micro could totally transform it for you.

Our range of programs cover Games, Household, Education and Business. We've shown just a few titles above;

come and browse round the rest at Micropoint.

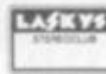

A service provided in association with Unicredit Finance Ltd. Please ask for written details. APR 29.8% if you pay by Banker's Order (34.9% for other methods of payment).

\* All credit offers subject to acceptance Laskeys Credit brokers. Please ask for written details. All offers are subject to availability. Prices include 15% VAT and are correct at time of going to press 1/3/83 but may be subject to variation thereafter.

The Retail Division of The Ladbroke Group



**LONDON & HOME COUNTIES**  
42 Tottenham Court Road, W1  
257 Tottenham Court Road, W1  
7-9 Queensway, W2  
471-473 Oxford Street, W1  
382 Edgware Road, W2  
152 Fleet Street, EC2  
Golders Green Road, NW11  
BROMLEY 22 Market Square  
COLCHESTER 13 Trinity Square

**CROYDON** Whitgift Centre  
**KINGSTON** Eden Street  
**LUTON** 192 Arndale Centre  
**READING** Friar Street  
**RICHMOND** Hill Street  
**ROMFORD** South Street  
**SLOUGH** Queensmeire Centre  
**WATFORD** Charter Place  
**SOUTHERN ENGLAND**  
**BRIGHTON** 151-2 Western Road

**BRISTOL** 16-20 Penn Street  
**CHATHAM** 8 The Pentagon  
**GLOUCESTER** 25 Eastgate Street  
**MAIDSTONE** 79-81 Week Street  
**SOUTHEND** 205-206 Churchill West  
**MIDLANDS AND NORTH**  
**BIRMINGHAM** 19-21 Corporation St.  
**CHESTER** 7 The Forum  
**LEICESTER** 45 Market Place South  
**LIVERPOOL** 33 Dale Street

**MANCHESTER** Arndale Centre  
(Adj) WH Smith  
**MANCHESTER** 12-14 St. Mary's Gate  
**NEWCASTLE-UPON-TYNE**  
6 Northumberland St.  
**NORTHAMPTON** 78 Abington Street  
**NOTTINGHAM** 1-4 Smithy Row  
**OXFORD** 16 Westgate  
**PETERBOROUGH** Queensgate Centre  
**PRESTON** Guildhall Arcade

**SHEFFIELD** 58 Leopold Street  
**WOLVERHAMPTON** 30 Wulfrun Way  
**YORK** 10a Coney Street  
**SCOTLAND**  
**EDINBURGH** 4 St. James' Centre  
**GLASGOW** 66-70 Buchanan Street  
**WALES**  
**CARDIFF** 122 Queen Street

† Normal domestic use on computers/VDU/Peripherals - programs 1 year. (Commercial use on computers/VDU 1 year. Peripherals - programs 6 months). Programs will only be exchanged if proven faulty and then only for the same program.

## DO YOU PLAY T.V. GAMES?

If so, then why not send for details of our library of TV games cartridges for ATARI, INTELLIVISION & PHILIPS Video Computer Games?

WE ARE NOW ALSO INTRODUCING OUR LIBRARY OF CARTRIDGES FOR ATARI 400/800, VIC 20 & TEXAS TI99/4A.

For only £10 Life Membership, we offer you the most comprehensive library of the above TV & computer games on a daily rental basis of only 25 pence a day, with no postage and packing costs, and special discount purchase prices.

We are also offering a quality free gift to anyone joining us within 21 days.

So don't delay, send today for details of our fast growing Video & Computer Games Library, and get yourself a whole lotta fun!

S.A.E. to E&E Enterprises Ltd, P.O. Box 8, Saltash, Cornwall PL12 6YU.

Please include details of the system(s) owned.

# LEISUREMAIL

## BRINGS YOU THE PICK OF THE GAMES!

**GAMES - GAMES - GAMES!** More and more computer games hit the market every month, BUT THEY CAN'T ALL BE GOOD. So - let LEISUREMAIL short list the VERY BEST for you. Send 50p NOW for our big 'BEST OF THE BUNCH' catalogue. We select TOP QUALITY SOFTWARE FOR YOUR ZX81 - SPECTRUM - BBC MICRO - GENIE 2 - VIC 20 - DRAGON 32 - ATARI etc.

### SPECIAL THIS MONTH

New Generation **ESCAPE** for 16K Spectrum - voted by Sinclair User as 'best and most original game yet seen for Spectrum! Only £4.95 post paid. Simply amazing graphics. Also fabulous new release - **3D TUNNEL** - 16K and 48K versions for Spectrum on one tape - £5.95.

To:- LEISUREMAIL (CVG), 69, Long Lane, London EC1A 9EJ.

Please rush me your BUMPER CATALOGUE of TOP FLIGHT GAMES. I enclose 50p (refundable first order).

I enclose £..... for .... **ESCAPE** and/or ..... **3D TUNNEL**, plus free catalogue. OR debit my ACCESS/DINERS/AMEX account number .....

Name:- .....

Address:- .....

## R & R

### STAR TREK 48K

Rid the Galaxy of the evil Klingons, Protect your Star Bases from attack. ("Easy to play. Difficult to beat". Sinclair User Dec '82)



ONLY £4.95

### P-E-P

#### THE PROGRAM ENHANCEMENT PACKAGE FOR THE ZX81 (16K)

A suite of easy to use machine code routines designed to transform your Basic programs.

- DEFINED SCROLL REGION 1 line to whole screen
- SCROLL up or down
- FILL SCREEN any character
- CHANGE BACKGROUND
- CHANGE FOREGROUND
- INVERSE VIDEO
- FLASH SCREEN
- CLEAR SCREEN without changing print position

Supplied on tape with a BK DEMO PROGRAM and a FULL instruction booklet

ONLY £5.95

### 16K Spectrum GOLF

Hi-Res Full colour graphics. A game for 1 or 2 players. All the features of a full size course. THE family game. (Reviewed Sinclair User Oct '82)



ONLY £3.75

### GNASHER 16K

THE ULTIMATE MAZE GAME. Ghosts, Energy Pills, Bonus Fruit, Sound, Colour + much more. Starts easy. Becomes impossible.

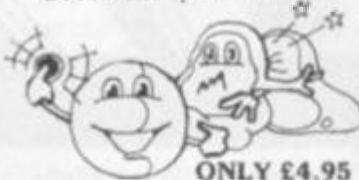

ONLY £4.95

Send to: **R & R SOFTWARE (CVG)** 48 HOUR DISPATCH  
34, Bourton Road, Gloucester GL4 0LE Overseas + 10% please  
Tel: GLOS (0452) 502819 Large Dealer Discounts

## ZX SPECTRUM

## TANGERINE CREATED

# ORIC-1 TANGERINE USERS GROUP CREATES THE REST!

AN INDEPENDENT INTERNATIONAL USERS GROUP

FOR PROGRESSIVE SUPPORT OF YOUR ORIC-1

MONTHLY NEWSLETTERS - SOFTWARE - HARDWARE - ADVICE - HINTS & TIPS

BEGINNERS - NEWS - REVIEWS - PLUS MEMBERS DISCOUNTS AND MORE !!!

START OFF WITH A USERS GROUP THAT KNOWS WHAT PEOPLE WANT !!!

FULL SYSTEM SUPPORT

OUR PEDIGREE SPEAKS FOR ITSELF WITH A PROVEN RECORD OF PERFORMANCE

ON THE £302 SYSTEM - PROGRESSIVE SUPPORT FOR OUR MEMBERS -

COME IN FROM THE COLD WITH TANGERINE USERS GROUP

"I'm very impressed with the system support you're providing" - S.Greenroyd.  
"Your support for the system is very good" - G.Gilmour - Germany  
"Keep up the excellent standards you have set" - B.Bull - Wiltshire  
"The newsletter is still magic!" - A.Brown - Scotland  
"Thanks for a super mag" - Dr.A.L.Challis - Warwick  
"Thanks for producing a superb newsletter" - D.A.Ellis - North  
"An excellent and valuable source of information" - N.J.Dennigan - Dorset.

Tangerine Users Group is here to help you where others leave off :-

SEND S.A.E. (A4) FOR DETAILS:-  
MEMBERSHIP:- Europe £15.00 - 12 Months Access & Barclaycard  
Other Countries £22.50 - 12 Months

Please make cheques payable to:-

TANGERINE USERS GROUP LTD  
1 MARLBOROUGH DRIVE, WORLE, AVON, BSS22 0DQ - Tel: (0934) 21313



**THE BEST** INDEPENDENTLY PRODUCED **BBC MICRO SOFTWARE**  
**BBC** TOP QUALITY MACHINE CODE PROGRAMS **BBC**

**SPECIAL OFFER!**  
 Deduct £1 per cassette or disc when ordering 2 or more.

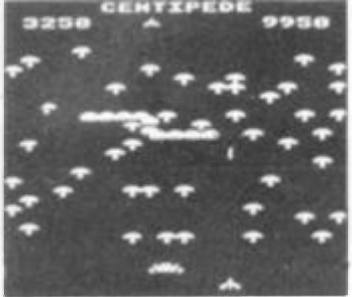
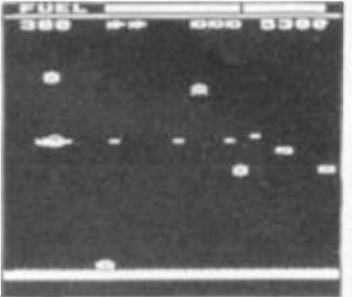
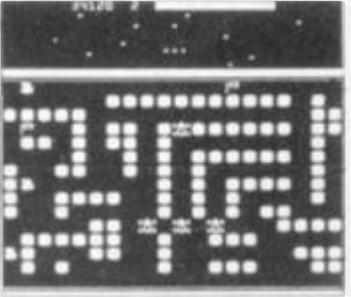
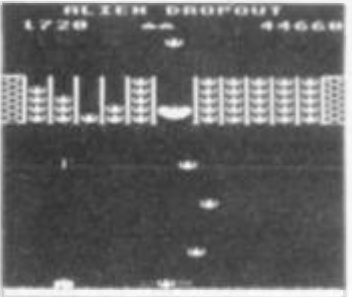
			
<b>CENTIPEDE (32K)</b> £6.50 Incredible arcade type game featuring mushrooms, snails, flies, spiders and the centipedes of course. Excellent graphics and sound. 6 skill levels, hi-score, rankings, bonuses, and increasing difficulty as the spiders become more active and the number of mushrooms increases. R.M.P. Hanson	<b>SPACE FIGHTER (32K)</b> £6.50 Arcade-style game based upon features from DEFENDER and SCRAMBLE. 5 types of menacing alien fire at you and may attempt to ram you. Separate attack phases, fuel dumps, repeating laser cannon, asteroids, smart bombs, hi-score, rankings, 6 skill levels, sound effects. R.M.P. Hanson	<b>ROAD RUNNER (32K)</b> £6.50 The only full feature machine-code version of the arcade game available for the BBC micro. Features include: scrolling screen, radar display, checkpoint flags, fuel gauge, smoke screens, 6 skill levels, rankings, increasing difficulty, and sound effects. R.M.P. Hanson	<b>ALIEN DROPOUT (32K)</b> £6.50 Based upon the arcade game of ZYGON, but our version improves upon the original arcade game itself. You have to shoot the aliens out of their "boxes" before the "boxes" fill up. Once full, the aliens fly down relentlessly, exploding as they hit the ground. Suitable for use with keyboard or joysticks. R.M.P. Hanson
<b>GALAXIANS (32K)</b> £6.50 Fast action version of the popular arcade game. 4 types of Galaxian (in 3 initial screen formations) swoop down individually or in groups of two or three. 6 skill levels, high score, rankings, bonus laser bases and increasing difficulty. Superb sound effects and graphics.	<b>INVADERS (32K)</b> £6.50 Superb version of the old classic arcade game, including a few extras: 48 marching invaders drop bombs that erode your defences, and two types of spaceship fly over releasing large bombs that penetrate through your defences. Increasing difficulty, high score, superb graphics and sound.	<b>FRUIT MACHINE (32K)</b> £6.50 Probably the best fruit machine implementation on the market. This program has it all... HOLD, NUJGE, GAMBLE, spinning reels, realistic fruits and sound effects, multiple winning lines. This is THE fruit machine program to buy.	

**SUPERIOR SOFTWARE**  
 Dept. cvg2  
 69 Leeds Road, Bramhope, Leeds.  
 Tel. 0532-842714

**DISC SOFTWARE AVAILABLE NOW**  
 All our programs are ready for despatch on 5 1/4" discs at £9.90 each. Alternatively, all 7 programmes are available on a single disc for just £49.90p.

**WE GUARANTEE THAT:**  
 (1) All our software runs correctly on all current operating systems.  
 (2) All our software is available before we advertise.  
 (3) All our software is despatched within 48 hours by first class post.  
 (4) In the unlikely event that any of our software fails to load, return your cassette or disc to us and we will immediately send a replacement.

PLEASE ADD 50p per order for p. & p. + V.A.T. at 15%.  
 We pay 25% royalties for high quality programs.  
 Dealer enquiries Welcome.

# CHANNEL 8 SOFTWARE

**EXCLUSIVE**

**16K Adventures FOR ATARI** by Brian Howarth

Enter the fantasy world of Britain's leading adventure writer. Travel in the Time Machine, seek the Golden Baton, avoid The Arrow of Death (a two part adventure). If you have 32k then try to Escape from Pulsar 7. Join the Circus or conduct the Feasibility Experiment. All on cassette. Only £17.99 each.

**GENUINE ATARI 16K Ram Boards only £39.90**  
**NEW LOW PRICE — ATARI 400 16K with Basic £199.00**

**THE BLACK SQUID.** An exciting new game for Vic 20 owners. Needs 3k extra memory. Cass. £9.95.

**DO YOU WRITE PROGRAMS ON YOUR ATARI?  
 DO YOU FIND IT DIFFICULT TO CREATE  
 ANIMATED PLAYERS? THEN YOU NEED**

## THE CONSTRUCTOR

In a few minutes even a complete novice can build an animated sequence up to 250 scenes long. 48k disk £24.95.

**We carry one of the largest stocks of Atari software in the country. This has now been extended to include BBC, ZX81, Spectrum, Vic 20 and Dragon machines. Write or phone your order. Access and Barclaycard welcome.**

**DEALERS**  
 If you haven't set up an account with Channel 8 yet then write now for trade terms and price list.

**CHANNEL 8 SOFTWARE LTD, 51 FISHERGATE, PRESTON, LANCASHIRE PR1 8BH**  
**TELEPHONE: (0772) 53057**



# M. C. LOTHLORIEN

A message for all Dragon and Sinclair owners

## BEWARE THE IDES OF MARCH!

(all the best prophecies are late)

### ROMAN EMPIRE

Our largest selling Spectrum game will be available for the Dragon 32 from April 1983 (yes we have avoided the Ides of March, poor old Caesar). The game will test your generalship as you build your armies, appoint generals and fight campaigns in your attempt to conquer armies in provinces of the Roman Empire. This challenging game takes full account of troop morale, fighting efficiencies, leadership ability etc. Three levels of play giving many hours of satisfaction. **DRAGON, SPECTRUM 16K, ZX81 16K.**



### WARLORD (Dragon 32 and ZX81 16K)

Rule a village in 13th Century Japan, plan food production, attack and defend against other Warlords and their Samurai. Face leadership challenges. The penalty for failure is DEATH for you and your family! Three levels of play (ZX81 version does not contain ALL the above features).

### TYRANT OF ATHENS (ZX81 and Spectrum 16K) Dragon

Can you survive long enough to turn Athens into the most feared state in the Mediterranean? Train troops, build warships, fight battles by land and sea against hostile Greek States and the vast Persian Empire. Many more features in this, our best selling game.

### SAMURAI WARRIOR (ZX81 and Spectrum 16K) Dragon

How would you have fared as a Samurai in 13th Century Japan? Face challenges from other Samurai, give aid to villages and resist attacks by groups of marauding bandits. 7 levels of play, a most fascinating game. Are you a survivor or will you commit ritual suicide?

For ZX81 16K only **PELOPONNESIAN WAR** (see previous adverts for details).

All games contain comprehensive playing instructions, all Dragon titles feature high resolution graphics (many with maps), all ZX81 need 16K Ram, all Spectrum will run on 16 or 48K. **PRICE DRAGON £6.95; SPECTRUM £5.50; ZX81 £4.50.**

Cheques and PO's please, made payable to: M. C. Lothlorien,  
Dept. C4, 4 Granby Road, Cheadle Hulme, Cheadle, Cheshire SK8 6LS.



# ZX SPECTRUM

## GHOST'S REVENGE

At last a maze-chaser game for the Spectrum that rivals the arcade original. Written in super fast machine code and featuring some of the best graphics, colours and sounds for the Spectrum. ★ Joystick or keyboard operation ★ Realistic gobble action in all 4 directions ★ Four intelligent ghosts that will chase or run from you ★ Pulsating power pills that change the ghosts' colours ★ Eat the running ghosts for 400, 800, 1200, 1600 bonus points ★ Skill level selection enables both beginners and experts to play ★ Harder levels feature invisible mazes ★ Full sound effects, tunes and top score.

**DESPATCHED BY 1ST CLASS RETURN POST**

**ONLY £5.95** including 1st class  
post, packing

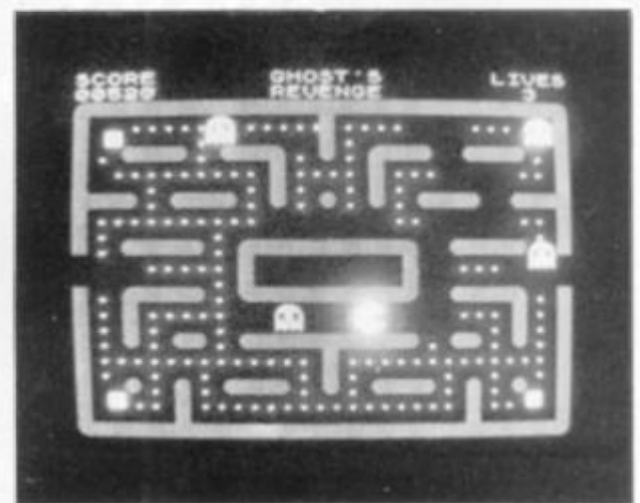

C&VG1

Post coupon now to: MICROMANIA SOFTWARE, 14 Lower Hill Road, Epsom, Surrey KT19 8LT.

Please rush me

copies of GHOST'S REVENGE @ £5.95

I enclose cheque/PO/cash for £\_\_\_\_\_

Sorry no credit cards.

NAME \_\_\_\_\_

ADDRESS \_\_\_\_\_

Micromania

# A NEW SERIES FOR FIRST TIME USERS

"Learning to Use" is a new series of books which introduces newcomers to the most widely used micros in the marketplace.

The books assume absolutely no knowledge about computers and the reader is shown even the most fundamental operations such as "switching on" and "loading a program". The books lead the reader through simple programming and then on to graphics, with several programs which show how to achieve pictures and even animation!

The user-friendly approach is consistent throughout the text – not only are program listings clearly shown, but in many cases, a photograph is included to show what the program looks like when actually loaded and run!

All books in the series are £5.95 (incl. postage). **Gower**



*To be published  
April–June 1983*

*Learning to Use the Apple II/IIe  
Computer (April)  
Learning to Use the Oric 1  
Computer (April)  
Learning to Use the Commodore  
64 Computer (May)  
Learning to Use the TI 99/4a  
Computer (May)  
Learning to Use the Lynx  
Computer (June)*

**READ-OUT**

Order Form to: **READ-OUT BOOKS AND SOFTWARE**

8 CAMP ROAD, FARNBOROUGH, HANTS, GU24 6EW.  
24 Hour Answering Service. Telephone 0252 510331/2

Name \_\_\_\_\_

Address \_\_\_\_\_

Make cheques payable to Newtech Publishing Ltd I enclose my cheque for £ \_\_\_\_\_

Please debit my Access  Signed \_\_\_\_\_

Number                      Date \_\_\_\_\_

**NOW AVAILABLE**

Please send me .....copy/ies all at £5.95 each  
incl. postage & packing. (Allow 14 days for delivery.)

<input type="checkbox"/> Learning to Use the PET Computer	<input type="checkbox"/> Learning to Use the VIC-20 Computer
<input type="checkbox"/> Learning to Use the BBC Microcomputer	<input type="checkbox"/> Learning to Use the ZX81 Computer
<input type="checkbox"/> Learning to Use the ZX Spectrum	<input type="checkbox"/> Learning to Use the Dragon 32

**To be published**

Please reserve for me, and send to me on publication my copy/ies of all at £5.95 each (incl. post & packing)

<input type="checkbox"/> Learning to Use the Apple II / IIe	<input type="checkbox"/> Learning to Use the TI 99/4a
<input type="checkbox"/> Learning to Use the Oric 1	<input type="checkbox"/> Learning to Use the Lynx
<input type="checkbox"/> Learning to Use the Commodore 64	

# THE EVOLUTION OF COMPUTER & VIDEO GAMES (PART 1)

BACK ISSUES



*Most computer historians agree that the first known remains of Computer & Video Games date from November 1981. It was then that this magazine first emerged (a little unsteadily) into the primeval twilight of the early days of Sinclair Man.*

*Then huge computer dinosaurs roamed the Earth, thrusting keen young programmers into their wall-to-wall maws and the magazine looked a little out-of-place surviving on a diet of strange new features and listing material washed up from across the Atlantic.*

*Naturalists are only now beginning to draw conclusions about the close association between the Computer & Video Games story and a little yellow gobbling creature's own evolutionary niche ...*

*Let us take a closer look at some of the noteworthy steps in the evolution of both:-*

## November 1981

The stripling emerges into twilight with Tarot on the Tandy, Musical Hangman on the Sharp MZ-80K, Trench on the Atari, Nibblers on the Pet and Super Nim on the Apple. Keith Campbell kicked off his popular Adventure series, Garry Marshall kicked off graphics with a space invader. There were Pacman arcade tips and Max Bramer looked at the first chess machine, Von Kempelen's Turk.

## December 1981

Growing up fast with Potshot on the Vic-20, Breakout on the Atom, 'Round the Horn' on the Tandy, Mini Golf on the Atari and Pet owners could tackle Rubik's Cube with more confidence. Keith Mott went trouble-shooting on the ZX81 in Kit Korner and Screaming Foul-up fell in love with Terry Wogan.

## January 1982

A new year begins with Ted Ball on the trail of the Bugs in his Practical Programming column. Speed Race for the Texas, Treasure Hunt was a popular Apple adventure — much converted by owners of other machines, three 1K wonders for the ZX81 and Changing Hearts for Atari owners. We also saw a seamier side to gaming with a feature on Softporn Adventure!

## February 1982

Science Fiction author David Langford brought a new look to space games with Space Blockade. Dr Livingstone set up a quest for Sharp owners and Grand Prix gave Tandy owners a racetrack to try out. David Annal POKEd some sounds out of the quieter

micros and Arcade Action announced two Pacman lookalikes.

## March 1982

Robin Bradbeer reported from Las Vegas on a country going video crazy — how right he was. ZX81 owners got to grips with Reversi (Othello), there was Startrek III.4 for the Tandy and Octodraw had the Atari moving in eight directions at once.

## April 1982

Spring came with Tim Metcalfe's feature on pinball, a revitalised sector of the arcades fighting back against Space Invaders. Engineer helped Atari owners rebuild the Golden Gate Bridge, Poker for the ZX81 and Ron Potkin's classic Tandy wargame Kriegspiel. Plus Pacman hit the home Video Screens at last.

## May 1982

Computer Moderated Games were investigated by Terry Pratt (the first thoughts on Seventh Empire were voiced about here). Minotaur took the Vic-20 down into a maze and tried to lose it, Pacman arrived in a C&VG listing on a Pet, Minopoly for up to five Sharp businessmen, Meteorstorm took Apple owners by surprise and Earthport II won Tandy fans.

## June 1982

The World Cup was upon us and we responded with World Cup Manager — written for the Sharp but without a PEEK or POKE and since converted to many a micro. Vic-20 owners were set afloat on a river torrent in Speedboat, there was Trolls Gold on the Apple and Dog Star Adventure on the Tandy.

It also included issue 1 of our BBC Micro publication, Owl.

## July 1982

Do the arcades have anything to offer the fairer sex? America was wooing women with Ms Pacman and we featured this first lady of the arcades in July. Imhotep took the Apple owners back to ancient Egypt, Moon Shuttle sent the Vic into space and Z-Xtra gave 16 pages over to Sinclair fans.

## August 1982

Haunted House gave Atoms a shudder, Space Hopper made Tandy's jump to it and Rocks made Vic owners roll over and beg for more. Imagic launched a range of cartridges for the Atari VCS. Hardcore was given over to a game-player's guide to the Atari and Sue Garden gave us all a giggle with a computer widow's tale.

## September 1982

Tron: out of the arcades came Walt Disney's graphically stirring film about being trapped in a computer game. We featured it first. Pacman appeared on the Vic-20, there was Star Wars on the Atom and Colditz Adventure on the Tandy. Issue two of Owl gave BBC owners Speed Trial and X marks the Spot.

## October 1982

C&VG saw out its first 12 issues with Space Watch on the Spectrum, asking you to befriend the aliens before it's too late! Sharp Defender, Galaxian Colony II on the Apple and the controversial Wild Strawberries on the Atari added to the action. And Pacman appeared in the Bugs cartoon!

# THE MicroComputer SOFTWARE CLUB

**FOR OWNERS OF  
VIC, ZX81,  
SPECTRUM, BBC,  
OR DRAGON  
MICROCOMPUTERS**

Buying software for your computer is a gamble. Apart from the occasional review and, perhaps, a recommendation from a friend, you have precious little information upon which to base your purchasing decision.

Advertisements and clever packaging can make the the worst programs appear tremendous. It is not until you have 'gambled' your money that you discover how good they really are. Some are only slightly different to others you may already own; many are not as good as you would be entitled to expect; and others are just a complete waste of money. Of course, there are some excellent programs around, and many more appear month. Now there is a safe way of finding out about them.

## - free membership -

THE MICROCOMPUTER SOFTWARE CLUB was started to make software purchasing easier, cheaper, and less risky. Membership is completely free of charge, as is the monthly Newsletter. Every month members receive full details on the best and latest programs available for their computer and, simply and confidently, are able to order any of the programs they choose at substantially less than normal prices.

## Free membership application

Please accept my application and enrol me as a member of The Microcomputer Software Club. I understand that membership is free of charge.

As a member I will receive the Club Newsletter free of charge and will be entitled to benefit from any savings offered to members on selected programs for microcomputers. I may cancel my membership at any time.

When completed, return form to:-

THE MICROCOMPUTER SOFTWARE CLUB  
P.O.Box 166, Oxford, OX2 9BJ, England.

NAME

ADDRESS

CITY

POSTCODE  AGE (If under 18)

COMPUTER MODEL  COMPUTER RAM

SIGNATURE

## large savings on top software

All programs are, at least, 10% cheaper than normal and, each month, the best of the most recent software is made available to members at 20% less than normal. Postage and packing is free on orders of two or more programs for delivery within the UK; ordering and payment are simple, and quality is guaranteed.

## no obligation

Members are not obliged to buy a fixed number of programs from The Club. They buy what they want when they want. Whether it is one program in a year or one a month, they know that when they buy from THE MICROCOMPUTER SOFTWARE CLUB they are buying the best programs at the best prices.

## free Newsletter

Our latest Newsletter offers programs from most leading suppliers - and from a few that, perhaps, you do not yet know. A program has to be good, very good, before it is recommended to members. It also has to be reliable and, even before the members' discount, it has to be good value for money. Subject coverage includes adventure, arcade, education, strategy games, household applications, family games, business, utilities and programming aids.

Remember, membership is completely free of charge and you are under no obligation to buy anything from The Club unless you really want to. If you own or use a ZX81(16K), Spectrum(16K or 48K), BBC (A or B), Dragon 32, or VIC (expanded or unexpanded), you should join THE CLUB.

# JOIN TODAY

THE MICROCOMPUTER SOFTWARE CLUB  
P.O.Box 166, Oxford, OX2 9BJ, England.

**For trade eyes only.**

A message from Britain's leading distributors of Atari 400/800® software:

# CentreSoft

As Softcell, we led the way in the supply of top-quality software for Atari®.

Now, with a change of name to CentreSoft and a greatly expanded operation, we not only continue to lead the way for Atari software, but we also now supply high-quality software for the Vic 20, the Commodore 64 and the Texas Instruments range of microcomputers. Contact us now for more details.

## CentreSoft

26 Great Cornbow, Halesowen, West Midlands B63 3AE. Tel. 021-550 8263

We supply products to:

Laskys

John Menzies

Gemini, Manchester

Norman Audio, Preston

Visionstore, Surrey

York Computers, York

Microchip, Winchester

Efficient Chips, Chippenham

We supply products to:

Micro-C

Spectrum Group

Silica Shop, Kent

Landau Electronics, London

May's Hi-Fi, Leicester

Games Workshop

Silicon Chip, Slough

Gamer, Brighton

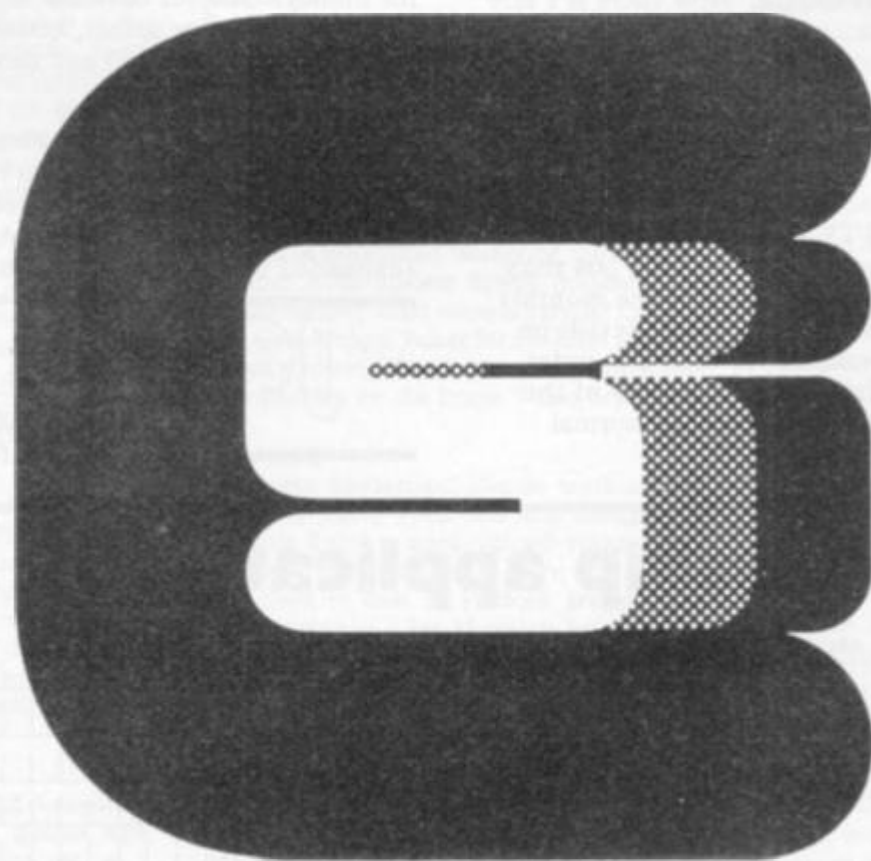

Atari, Atari 400 and Atari 800 are registered trademarks of Atari Inc

## MAIL ORDER PROTECTION SCHEME

Members of the Periodical Publishers Association have given to the Director General of Fair Trading an undertaking to refund monies sent by readers in response to mail order advertisements (except for classified advertisements) placed by mail order traders who fail to supply goods or refund the monies owing to liquidation or bankruptcy. This arrangement does not apply to any failure to supply goods advertised in a catalogue or in a direct mail solicitation. Publishers in membership of the Periodical Publishers Association are making these refunds voluntarily and readers' claims can only be entertained if the following conditions are fulfilled:

1. The mail order advertiser is the subject of liquidation or bankruptcy.
2. The reader can establish proof of payment.
3. The reader has informed the publisher immediately if the goods or a refund have not been received 28 days after date of placing the order.
4. The reader has lodged a claim within 3 months of date of appearance of advertisement.

Any claim or notification received after these stated periods will be considered at the discretion of the publishers.

# FREE

# COMPUTER GAMES

## SPECIAL OFFER FROM THE UK'S LEADING GAMES LIBRARY

Hire your first computer game for free!! Too good to be true? Not if you accept our generous introductory offer.

We can supply a comprehensive range of top name computer games on cassette, cartridge and disc and can cater for most major Home Computers.

Just send your name and address to Supasoft and we'll offer you your choice of computer game for hire absolutely free of charge. Write today to:

**SUPASOFT GAMES LIBRARY**  
2 Station Rd., Hammerwich, Walsall,  
W. Mids.

### YOU NEED NEVER BUY A VIDEO GAME AGAIN

## pancom

### New Releases for the Atari VCS

<b>Coleco</b>		<b>Dimax</b>	
Donkey Kong	27.95	Astro Chase	21.95
Mousetrap	27.95	Space Robot	21.95
Gorf	27.95	<b>Tigervision</b>	
<b>Onbase</b>		King Kong	23.95
Assault	21.95	Threshold	21.95
<b>Activision</b>		Jawbreaker	23.95
Megamania	21.95	<b>20th Century Fox</b>	
Pitfall	21.95	Turmoil	26.95
Spider Fighter	21.95	Alien	26.95
Sea Quest	21.95	Worm War	26.95
		Beany Bopper	26.95
<b>Special Offer for March:</b> Limited availability.			
Pac Man	23.95	Defender	23.95

**Joysticks** Le Stick: Red Ball: Track Ball: Trak Ball: Quick Shot:

### Best sellers in Atari 400-800 software

Our selection . . . full lists on request.

Frogger 16K 32K 22.95	Zaxxon D/C 26.25
Choplifter 48K 23.05	Gorf 16K 26.25 16K Cart 29.55
Centipede 8K Cart 30.45	Planet Miners 24K 10.50
Shamus 16K 16K 22.95	Voyager 32K 16.45
Deadline 32K 32.85	Shootout at OK Galaxy 16K 13.15
Canyon Climber 16K 16K 19.65	Legionaire 16K 23.05
Zork I 32K 26.25	B.I. Nuclear Bomber 16K 10.50
Galaxian Cart 30.45	Moon Patrol C 16.45
Preppie 16K 32K 19.65	Stellar Shuttle 16K 32K 16.35
Snooper Troops 1 48K 29.55	Starbase Hyperion 24K 15.05
Snooper Troops 2 48K 29.55	24K 13.15
Ultima 2 48K 39.45	Jeepers Creepers 32K 19.75
Defender Cart 30.45	Sneakers 48K 19.70
Zork 2 32K 26.25	O'Reillys Mine 16K 16K 22.95
Rearguard 16K 13.15 24K 16.45	Mission Asteroids 40K 16.40
Star Raiders Cart 30.45	Starcross 32K 26.25
Lunar Lander 24K 9.85 32K 13.75	Qix Cart 30.45
Miner 2049 16K Cart 32.85	Mouseattack 32K 22.95

For full lists send 9" x 4" stamped addressed envelope stating VCS or Software. Postage, etc., 60p per item. Two or more post free.

Mail order & enquiries: Pancom, 6 Tranby Drive, Grimsby, S. Humbs.

Telephone: (0472) 694196 Mon. to Fri. 9am to 5.30p.m.  
Sat 9am to 12pm.

## SPECTRUM 16/48 ZX81-16K/DRAGON 32/BBC A+B

### ADVENTURE 200 (16k)

OVER 200 PLACES to explore. Written in machine code and using advanced data compression techniques it squeezes a true fixed-map adventure into just 16K — all held in ram — no extra cassette reads or books of text. Unlike a randomly generated maze type game this is a real test of your tactical skill. It starts easy but the further you progress the more dangerous and difficult the problems become as you use objects around you to overcome obstacles and you are the hero! Flexible command format allows abbreviation multiple word lines.

Other games from Foilcade include:

AWARI — Ancient African game of logic

FANTASTIC VOYAGE — (ZX81 16K only) Real-time simulation of micro-sub in human body. Real vascular map and fast m/code graphics.

THE FOILKADE CHALLENGE: Buy both Adventure and Awari and enter our prize competition. SAE for details.

All games £5.95 inc. 2 for £9.95 3 for £13.95

## £1000 IN PRIZES

## FOILKADE LTD

Dept CVG, 66 LITTLEDEAN, YATE, BRISTOL BS17 4UQ

## HAVE YOU GOT A BBC MICRO? THEN YOU NEED:



**WE WON'T TRY TO PUSH LASERBUG ON YOU LIKE THE OTHERS - SEND OFF FOR A SAMPLE COPY AND YOU'LL FIND THAT LASERBUG SELLS ITSELF**

*AVAILABLE... BBC DUST COVERS AVAILABLE... BBC DUST C*

Specially made LASERBUG Dust Covers available for only £3.25 inclusive. Made of high quality polyester/cotton which is better than the less attractive PVC ones. Anti-static and in a complimentary colour. Use the form at the bottom to order.

*ERS AVAILABLE... BBC DUST COVERS AVAILABLE... BBC*

Please supply me with:

A sample copy of LASERBUG @ £1.00

A 12 Month subscription to LASERBUG @ £12.00 for 12 issues of the magazine

A 6 Month subscription to LASERBUG @ £6.00 for 6 issues of the magazine

An overseas subscription to LASERBUG @ £14.00 (Surface Mail - write for details of air mail)

..... LASERBUG Dust Cover(s) @ £3.25 each

I enclose a cheque/PO for £..... made payable to LASERBUG

NAME .....

ADDRESS .....

Please send the completed form to: LASERBUG Dept. CVG,  
10 Dawley Ride, Colnbrook, Slough, Berks., SL3 0QH.

## Insurance Scheme for Personal Computers

### BREAKDOWN AND ACCIDENTAL LOSS OR DAMAGE

Covering personal computers and all peripherals dedicated exclusively for use with personal computers. All this equipment is insured in private houses, educational establishments, temporarily in offices.

The computer must be less than two years old when it is first insured.

The annual premium if you live anywhere in the U.K.

Value of Equipment	Annual Premium
£100	£ 7.50
£200	£ 9.75
£300	£11.50
£400	£13.75
£500	£15.00
£750	£23.50
£1000	£32.50

For full details and an application form complete the coupon and send to Graham Brown & Co. (Guildford) Ltd. For phone enquiries contact Mr C C Bower or Mr J C Austin.

Name .....

Address .....



**Graham Brown & Co. (Guildford) Ltd.**  
Registered Insurance Brokers  
Pannells Court, Guildford, Surrey GU1 4EY Tel: 048 863651



## LYVERSOF

### HIGH QUALITY GAMES SOFTWARE

#### SPACE ASSAULT (3 or 8K VIC 20)

Pilot your space craft home through the alien held territory of valleys and caverns. Watch for the friendly fuel dumps on the way.

#### LUNAR RESCUE (Unexpanded VIC 20)

Three important scientists are trapped on the moon. You must rescue them through the meteor storms.

#### TWO GAME PACK (Unexpanded VIC 20)

#### CRAZY CLIMBER

Climb the scaffolding and catch the balloons as they float past.

#### APPLE BUG

Eat the apples before the bug gets you.

#### BOUNCING BABIES (ZX81, 16K)

The orphanage is on fire, your ambulance team has to save the babies as they fall from the windows...

#### ALL GAMES £5.95

Contact us for more details:

LYVERSOF,  
66 LIME STREET,  
LIVERPOOL L1 1JN.  
051-708 7100.

66 LIME STREET  
LIVERPOOL  
051 708 7100

## ELECTRONIC LEISURE PRODUCTS

MAIL ORDER DEPT:  
6 Meadowvale Close,  
Raheen, Limerick,  
Ireland  
Phone: 27522

### STARPATH SUPERCHARGER £44.50 (Excl. VAT)

Turn your Atari Video Computer System into a super charged video game machine, with a "Starpath Supercharger" from Electronic Leisure Products.

Slip the "Starpath Supercharger" into the cartridge slot of your Atari VCS and enter the next dimension in video game excitement. "The Supercharger" gives your Atari the game-playing power of sets costing many pounds more. And "Supercharger" game programs cost 40% to 60% less than conventional cartridges.

Start with Phaser Patrol, the extraordinary Galactic Odyssey that comes with "The Supercharger". Plot your strategy and then fight it out with the enemy on an incredibly detailed battle action screen.

Included with Phaser Patrol are action previews of three other "Starpath Supercharger" games.

"Supercharger" games come on cassette and load via the ear phone socket on most standard tape recorders.

Other games available are:

#### COMMUNIST MUTANTS FROM SPACE

£14.00 Excluding VAT

#### FIREBALL

#### SUICIDE MISSION

#### KILLER SATELLITES

#### ESCAPE FROM THE

#### MINDMASTER

£16.65 Excluding VAT

#### DRAGON STOMPER

The Superchargers on offer in this ad are adjusted NTSC Colour System Products. However they should be compatible with all T.V.'s having a variable/horizontal hold button on the back of the set.

Cheques should be made payable to **ELECTRONIC LEISURE PRODUCTS.**



### ATARI 400/800 SOFTWARE

Why spend a fortune on software when you can hire all the very latest released games etc. at a most comprehensive rate? We have an all-round selection of disks, cassettes and cartridges awaiting your Atari 400/800. Apply now and hire your first 2 games free. For full details send stamped addressed envelope or phone evenings 7pm-10pm or weekends. (0783) 286351.

Games & Software Library, 35 Tilbury Road, Thorney Close, Sunderland SR3 4PB.

### TEXAS TI99/4A

**TX WARGAME** — The best TI Basic program available. Graphics are outstanding; Tactics, strategy and real time skill. Manoeuvre tanks and artillery across a terrain of woodland, marsh, lakes, hills and plains. Capture enemy bases and the high ground. **£6 inclusive**

#### TX SOFTWARE

109 Abbotswood, Harlow, Essex.



### ZX81·ZX SPECTRUM· DRAGON 32·VIC·20·BBC

The very best mail order items "over the counter"

Games, Keyboards, Serious Programs, Rams, Books, Peripherals and much, much more!

FAST MAIL ORDER SERVICE PHONE 01-769 2887  
WITH ACCESS/VISA (24hr Answerphone)  
or send large S.A.E. for catalogue (state which computer)

Open 10.30 - 5.30 Tues. to Sat. (closed Mondays)  
310 STREATHAM HIGH ROAD, LONDON SW16

### ATARI COMPUTER OWNERS

Make the most of your Atari 400/800 by hiring from our Software Library. We offer a wide selection of the many games and adventures on the market for your computer.

For full details send a S.A.E. to: **Star Hire, P.O. Box 48, Bracknell, Berks. RG12 4WD.**

### ZX81 Spectrum BBC VIC

#### GAMES CASSETTES

**ZX81 (16k) Super Invaders** ..... £4.95  
On-screen league tables. Game in machine code — "excellent... one of the two best... deservedly popular" (Pop. Comp. Weekly) "Great game!" S.F. (Glos).  
**ZX81 (16k) Lynchmob** ..... £4.95  
Exciting word game. 2-6 players. Excellent for the family. Great fun, educational too! Animation, on-screen scoring. Good Xmas present.  
**Spectrum (16k) Lynchmob** ..... £6.50  
As for ZX81 with added excitement of colour, sound and hi-res animation.  
**VIC-20 (unexpanded) Invaders** ..... £6.90  
Machine code, colour, sound.  
**BBC ("B") Bridgeman** ..... £7.90  
The popular gobble game. Hi-res, colour, sound.

Our motto — quality not quantity  
Prices all-inclusive — sent 1st Class by return  
"I must congratulate you not only on the quality of your goods but also on your excellent service" — G.W. Southall  
Applications software also available

**ZX81 16k RAM** Memotech Memopak 16K  
All-inclusive price ..... £28.50

Send s.a.e. for details of all our products  
Dept. CVG, 36 Fernwood,  
Marple Bridge, STOCKPORT,  
Ches SK6 5BE

Bridge  
Software

### STAINLESS SOFTWARE

Software for the TI 99/4A. Large illustrated catalogue. Imported & UK programs. 50p (Refundable on order) to: 10 Alstone Road, Stockport, Cheshire, SK4 5AH.

— MAIL ORDER ONLY —

### ZX81/SPECTRUM DO YOU LIKE MONOPOLY? OUR GAMES WILL APPEAL TO YOU

**NEW!**

**FARMER** is a simulation of running a large wheat farm. Decisions are required on when to plant, irrigate, fertilise, spray and harvest your land and whether to purchase seed corn, land or farm machinery or whether to employ more farm workers.

**DALLAS**. A game of oil exploitation in Texas. Decisions are required on purchasing concessions, the movement and use of drilling rigs, and the building of platforms and pipelines. Can you take-over the Eung Empire.

**AIRLINE**. You must decide on number of aircraft to operate, loan and fuel contracts, whether to buy or charter, and levels of staffing and maintenance.

**AUTOCHIEF**. As MD you must negotiate for leases, decide on menu prices, level of wages, advertising and dividends and forecast levels of inflation. If you are not successful you will be made to resign!

#### FOR THE EXPERT

**PRINT SHOP**. As owner of a printing company you have to decide on staffing, paper stocks, quotations, work schedule.

ALL PROGRAMS AVAILABLE  
FOR 16K ZX-81, SPECTRUM 16K

£5.00 for one, £8.50 for any two, £12.00 for three or £15.50 for four, £19.00 for five.

**C.C.S.**

Please state computer type and send cheque to Dept. V  
14 Langton Way  
London SE3 7TL

### ZX81 & SPECTRUM CARRYING CASES

Keep your computer safe and ready for instant use:

**ONLY £14.90 + £2.00 P&P**

Attractive black finish and red interior. Foam rubber protection. Please send cheque/P.O. to: **WOODENTOPS, 91 St Michaels Rd, Northampton.**

### PAGE 6 YOUR ATARI™ MAGAZINE

#### DO YOU OWN AN ATARI

Yes? Then learn more about programming, software and what is going on in the Atari world by subscribing to PAGE 6 — the premier Atari users magazine in the U.K. Written by Atari enthusiasts for all Atari users, the magazine includes listings, tutorials, news, reviews etc.

PAGE 6 is published bi-monthly and the annual subscription (6 issues) is £4.00 U.K./£7.00 Europe. Single copies (when available) 70p inc. p & p.

Issue 2 available NOW — Issue 3 due end of April.

Send to PAGE 6, 18 Underwood Close, Parkside, Stafford.  
Please make cheques payable to ABACUS.

### VORCON WARS

A hex based play by mail computer modulated game for strategists and Sci-Fi buffs alike. The playing area is the circumnavigable surface of the planet Vorcon, where you form alliances, battle and trade in your quest for nuclear domination. Movement and tactics along your borders are true simulations of the battle frontier, but without random aspects. For entry to 4th game send £1.50 which covers the first two turns and rule book, to: **J. Nicholson, 71 Juniper, Birch Hill, Bracknell, Berks.**



ESTUARY  
SOFTWARE  
**E.S.P.**  
PRODUCTS

42

A new name in Atari and Sinclair software

### HITCH-HIKERS GUIDE TO THE GALAXY

For Spectrum 48K £8.95 Please allow 28 days  
Apple II on disc £16.95 for delivery

261 VICTORIA AVE, SOUTHEND ON SEA, ESSEX  
CREDIT CARD HOLDERS PLEASE PHONE  
THE NUMBER  
(0702) 43568

### ATOM ADVENTURE A

Locally acclaimed game for the experienced adventurer. Over 50 locations crammed into 12K using m/c + Basic. £7.00.

**ATOMCREST SOFTWARE, 8 Hillcrest, Mayland, Chelmsford CM3 6AZ.**  
Tel: 0621 740608.

### ATARI 400/800 OWNERS

A comprehensive library of cassettes, cartridges, discs.

Scores of games and adventures etc., for you to hire for your Atari Home Computer.

All original games with full documentation. No copies

Send SAE for details to:

**MIDLAND GAMES LIBRARY**

48 Read Way, Bishops Cleeve,  
Cheltenham, Glos.

Tel. 0242-674960 6pm - 9pm only.

### Wizard Software

#### NEW RELEASES FOR DRAGON

**ALIENS** - £7.95  
A machine coded Arcade game presented in high resolution graphics. Features 48 invaders, mother ship, 4 defenders per wave, 4 shields + bonus shields. Continuous display of score during game.

**DRAGON STARTREK** £8.45  
A real time version featuring a 10 x 10 galaxy, shield control, photon torpedoes, status reports, signals received, galactic search, scanner control, warp drive, star bases with docking, black holes, planets and planet landfall, pulsars, novas, stars, asteroids, meteors, shuttles and shuttle docking and automatically converging and attacking Klingons. Four levels of difficulty. Comes with instruction manual.

All prices inclusive, mail order, cheques or postal orders to: **WIZARD SOFTWARE, P.O. BOX 23, DUNFERMLINE, FIFE KY11 5RW.**

Send S.A.E. for full program catalogue.



### MZ-80K GAMES

**SHOOTING GALLERY** Fast arcade game. 5 levels of play — watch out for the attacking snakes.

**HANGMAN** Guess the word before the computer hangs you. Re-programme the words.

**DOMINO** Very difficult to beat.

**GERMAN CLASS** Test your knowledge.

All four programs on one tape for only £8.00 incl. Cheques or P.O.'s to **TAYLOR, 8 Binham Close, Luton LU2 7AR**  
S.A.E. for more details.

#### TAKE INVENTORY

You've tried N, S, E and W and failed to find the particular treasure of your quest. Now is the time to "take inventory" at the Dragon Dungeon.

The Dungeon vaults are filled with peripherals, books, software and other goodies, exclusively, for the Dragon 32 owner — from recorder leads to Editor/Assemblers and from arcade games to Data Base Management Systems.

Our stock of software is selective, since we believe in value for money. Feed your Dragon on the best programs! Current best-seller: Salamander's superb 'Dragon Trek' (£9.95).

We try to stock everything published on the Dragon. Try the 'Dragon Companion' (£4.95) and discover 12 graphics modes! Current best-seller: David Lawrence's 'The Working Dragon 32' (£5.95). 'Text Star', which stores six pages of A4 per loading, now in stock (£12.95). Send for current listings.

#### DRAGON STICKS



Double-potentiometer joysticks for the Dragon owner who demands arcade action. Tough and reliable, Dragon Sticks keep on zapping when others fail! (£19.95 per pair).

#### DRAGON'S TEETH

Journal of the Dragon Owner's Club. 'Dragon's Teeth' is published monthly and contains news, reviews and information for dedicated Dragon-bashers.

Send for details (Annual sub. £6, Six-month trial sub. £3.25).



**THE DRAGON DUNGEON**  
P.O. Box 4, Ashbourne, Derbyshire  
DE6 1AQ.  
Telephone: Ashbourne 44626.

# Computaclub U.K.

WHY NOT JOIN COMPUTACLUB-U.K. AND HAVE A SOFTWARE LIBRARY AT YOUR FINGERTIPS?

Members can receive programs for up to half-price, YES, HALF-PRICE!

Most machines are catered for and ALL our software is guaranteed. But we don't just deal in games programs either. We have a comprehensive catalogue for you to browse through at your leisure.

So fill in the form below for a 6 month TRIAL MEMBERSHIP and accept a FREE games cassette (worth over £10) as our special opening offer to you the customer.

6 MONTH TRIAL MEMBERSHIP TO: COMPUTACLUB-UK, COMMERCIAL WORKS, CHURCH, ACCRINGTON, LANCASHIRE.

Date .....

Please accept me as a member of your club, and send me my FREE games cassette. I enclose my fee of £7, made payable to "Computa-Club-UK".

My Computer is ..... Storage Capacity .....

My Name is ..... (please use BLOCK CAPITALS)

My Address is .....

Tel: .....

Signed ..... Age (if under 18) .....

## At last . . . Exciting AND Challenging Computer Games for Two Players.

**CONFLICT** A total war for two players involving both the machinery (armies, missiles, warships) and finance (stock market, oil, piracy) of conflict. "I enjoyed this strategy game" (Computer and Video Games).

**GALAXY CONFLICT** Raise a fleet of Battle Eoncrisers then move from bridge to bridge taking full control and responsibility in this battle for the heavens. Born galactic rulers will do well. "Galaxy battle sets new trend" (Sinclair User).

Games Include — ZX81 (16K) and Spectrum (48K) programs on ONE cassette. Full size professionally printed board. Counters and markers. Two pads disposable maps (Conflict only). Comprehensive instructions/rules.

\*Professionally packaged in high quality attractive box.

\*Each game only £11.95 inc. Postage or £22 for both games.

\*Available from W. H. Smith, Buffer, Games Centres and many other retail outlets or mail order from:

**martech games**

9 Dillingburgh Road, Eastbourne  
East Sussex BN20 8LY



<p><b>soft toys</b> <b>VIC Attack!</b> An arcade game with Hi-Res. Machine Code and Joystick option for the unexpanded VIC 20</p>  <p>with Breakout</p>	<p><b>soft toys 1</b> <b>7 Games for VIC</b> Including - THE DEEP, CODE MAKER, PONTOON for 3.5k VIC, KILLER PARK, MUSIK for 8.5k VIC</p> 	<p><b>soft toys 2</b> <b>6 Games for 3k expanded VIC</b> - Lunar Lander, Casino, Simon Says, Maths Maze, 3-D Maze, Hangman</p> 
<p><b>soft toys</b> <b>The Lair</b> adventure for 16k VIC 20</p> 	<p><b>soft toys</b> <b>Star Warp II</b> A Fast-Action Realtime Space Adventure for 16k VIC 20</p> 	<p><b>soft toys</b> <b>Game Graphics &amp; Graphics Editor</b> A full-featured utility for Hi-Resolution customised graphics in your games. For the unexpanded VIC and VIC with 3k expansion.</p> 

\* SUPERB programs - AMAZING value !! \*

Write or 'phone for your catalogue now.

All prices include P&P 1st class. Send cheque/PO to:

**soft toys** 14, Lockharton Avenue, Edinburgh EH14 1AZ. Tel: 031 443 2005

**DEALER ENQUIRIES WELCOME.**

## ADVERTISEMENT INDEX

Acornsoft	22/23	Martech Games	114
Allrian	34	M C Lothlorien	106
Anirog Computers	8	Melbourne House Publishers	6
Bi-Pak	34	Microcomputer Software Club	109
Bug Bear	100	Microdeal	69
Bug Byte	29	Micromania	106
Calisto Computers	42	New Generation Software	97
Centre Soft	110	Palantir Programs	100
Channel 1	50	Pancom	111
Channel 8 Software	105	Personal Computing News	94/95
Chromasonic	4	Pulsar Software	115
Commodore	36/37	Ram Electronics	100
Computer Club UK	114	Read Out Books & Software	107
Digital Fantasia	53	Romik	60
DK'tronics	38/39	R&R Software	104
Dragon Data	46/47	Salamander Software	93
E&E Enterprises	104	Silica Shop	19
Electronequip	97	Sinclair Research	86/87
Electronic Leisure Products	112	Softtek	24
Folkade	111	Soft Toys	114
Gamer	34	Software Express	54/55
Gemini Electronics	91	Software Farm	107
Graham Brown	112	Software For All	96
Ibek Systems	82	Spectravision	2
Imagine	76/77/78/79/OBC	Spectrum	12/13/14/15
IPC Exhibitions	101	Superior Software	105
J K Greye	82	Supasoft Games Library	111
Laserbug	112	Tangerine Users Group	104
Lasky's	102/103	Titan Programs	97
Leisuremail	104	U.T.S.	34
Llamosoft Software	73	Vision Store	91
Lyversoft	112	W.H. Smith	26/27
Maplin	98/99		

# ALL THE FUN OF THE AIR

How do you fancy getting away from it all with a trip in our hot air balloon?

Sounds tempting doesn't it. But it takes skill and fast reactions to avoid all the hazards.

Are you up to it?

Could you manoeuvre the balloon over the tree tops and mountain peaks, while still keeping an eye on your ballast and your fuel because when it starts to run low you'll have to descend and not being distracted by people throwing stones at you land carefully on the fuel pods. You'll be lucky to rise back up again. But look out!!

Watch that kite doesn't become entangled with you and don't worry about that noise its only the aeroplanes that come diving and swooping at you. You'll need to rise higher to avoid the turbulence from the windmill blades but as you do you're likely to run into storm clouds and bolts of lightning. Also the higher you climb in the stratosphere the more difficult the balloon becomes to handle.

By now you'll start to panic!! and wonder how on earth you're going to make it, but then again that's all the fun of the air.

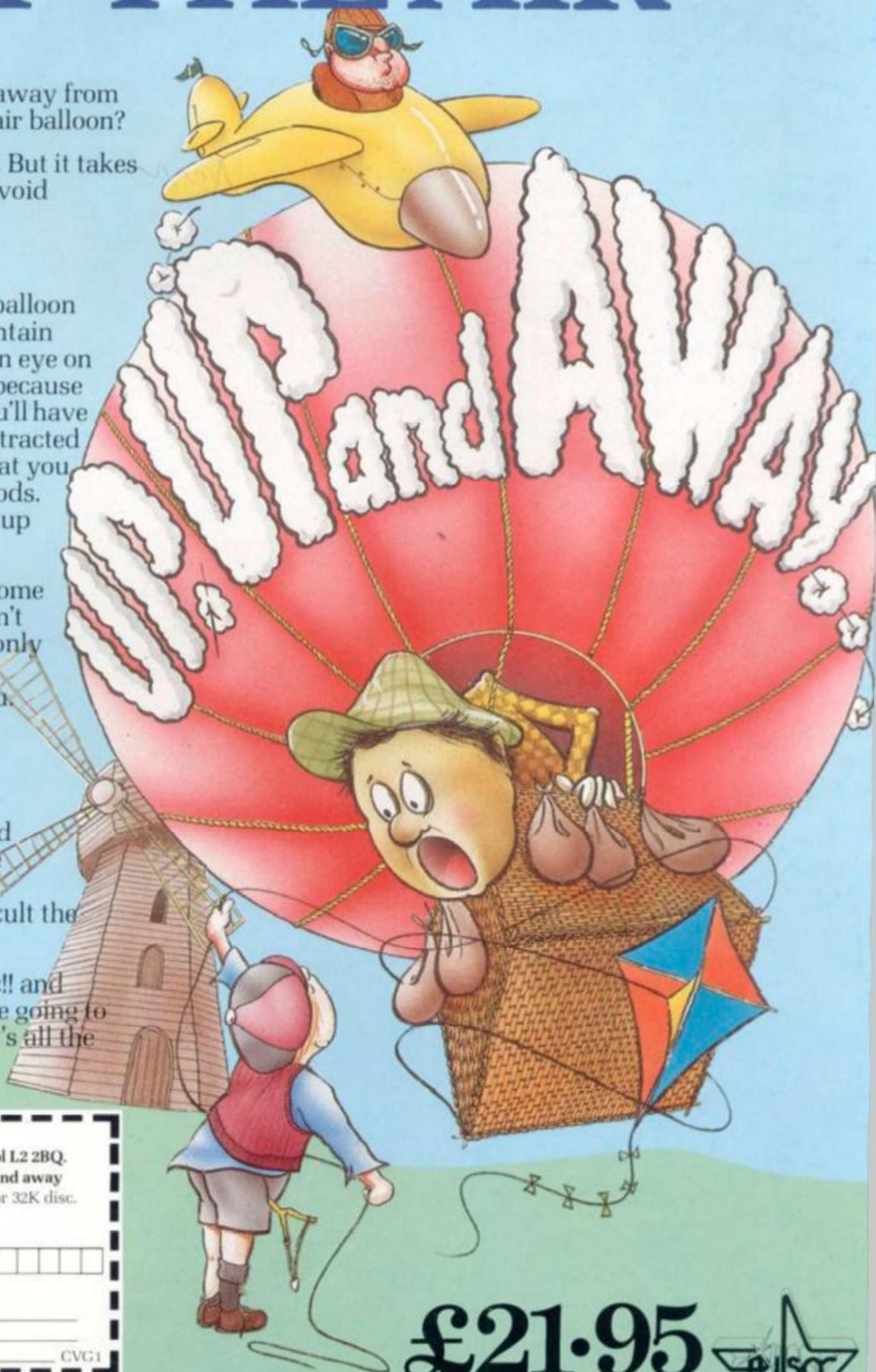

Post Coupon now to

**Pulsar Software, 15 Moorfields, Liverpool L2 2BQ.**

Please rush me \_\_\_\_\_ copies of **up, up and away**

Suitable for Atari 400/800 16K cassette or 32K disc.

Please debit my Access/Barclaycard

(Delete as necessary)

Card Number

I enclose cheque/P.O. for £\_\_\_\_\_

Name \_\_\_\_\_

Address \_\_\_\_\_

CVG1



SUPERFAST CREDIT CARD SALES LINE:

**051-236 2372 24hrs**



## £21.95



Pulsar Software, 15 Moorfields, Liverpool L2 2BQ.



*Merr*



**..the name  
of the game**

Imagine Software, Masons Buildings, Exchange Street East, Liverpool, Merseyside L2 3PN. Telephone: 051-236 0407