

MAY 1985

95p

£54.70
Dm6

COMPUTER & VIDEO GAMES

ADVENTURE EXCLUSIVE: THE WORLD'S GREATEST COMIC HEROES!

Fantastic Four®



TARIS '85

FREE: AMSTRAVAGANZA! REVIEWS, LISTINGS, COMPETITION, SORCERY MAP!
WIN ° SUPERSTAR SPORTS GEAR! **WIN** ° INTERCEPTOR'S BREAK FEVER SURVIVAL KIT! **WIN** ° CAULDRON'S GOLDEN BROOMSTICK!
EXCLUSIVE: THE JAMES BOND DIARY / **ALIEN-8** MAPPED!

The Fight Continues...

On The Spectrum.



... Earth is threatened by an Empire Deathstar, can you penetrate its defences, destroy it before it destroys you?
... Deathstar Interceptor gives you 12 screens of 3D graphics, super smooth 3D animation, unbelievable sound effects, music, 4 skill levels and a score table ... this is the ultimate challenge!

... This game has to be played to be believed! You have not seen what the 48K Spectrum is capable of until you have played Deathstar Interceptor!

Available now at £1.95

**Also available for
CBM £1.99**

HOW TO ORDER

To purchase Deathstar Interceptor, simply fill your name and address on a piece of paper, enclosing your cheque/P.O. made payable to: SYSTEM 3 SOFTWARE, and post to the address below. Please allow 7 to 14 days for delivery.

OVERSEAS ORDERS

Please add £1.00 per game ordered.

System 3 Software

South Bank House, Black Prince Road, London SE1
Tel: (01) 587 0873



Cover illustration and lettering: Jerry Paris

You could win yourself a copy of Scott Adams latest *Adventure Questprobe 3* if you turn to page 49.

Fantastic Four® copyright © 1985 by Marvel Comics Group, a division of Cadence Industries Corporation.



- Editor**
Tim Metcalfe
- Deputy Editor**
Wendie Pearson
- Editorial Assistant**
Lesley Walker
- Staff Writer/Reader Services**
Seamus St. John
- Designer**
Brian Cookman
- Production Editor**
Mary Morton
- Advertisement Manager**
Louise Matthews
- Assistant Advertisement Manager**
Bernard Dugdale
- Advertising Executive**
Sean Brennan
- Production Assistant**
Melanie Paulo
- Publisher**
Rita Lewis

Editorial and Advertisement Offices:
Priory Court, 30-32 Farringdon Lane
London EC1R 3AU
Tel: 01-251 6222

COMPUTER & VIDEO GAMES POSTAL SUBSCRIPTION SERVICE. By using the special Postal Subscription Service, copies of **COMPUTER & VIDEO GAMES** can be mailed direct from our offices each month to any address throughout the world. All subscription applications should be sent for processing to **COMPUTER & VIDEO GAMES** (Subscription Department), Competition House, Farndon Road, Market Harborough, Leicestershire. All orders should include the appropriate remittance, made payable to **COMPUTER & VIDEO GAMES**. Annual subscription rates (12 issues): UK and Eire £15. Additional service information, including individual overseas airmail rates, available upon request. Circulation Department: EMAP National Publications. Published and distributed by EMAP National Publications Ltd.
Printed by Severn Valley Press. Typeset by In-Step Ltd.

FEATURES

- ALIEN 8 MAP**.....8
C&VG and Dimension Graphics have teamed up to bring you an exclusive screen-by-screen breakdown of Ultimate's classic — *Alien 8*. Not to be missed!
- THE BOND DIARY**.....25
Bond is back — on the small screen too!
- CATCH BREAK FEVER**.....29
No, it's not fatal — but it's one way of working up a sweat!
- CAN YOU BEAT BRIAN JACKS?**.....33
If you can beat Brian Jacks then you really are a superstar!
- PROFESSOR VIDEO'S WORKSHOP**.....43
The Prof. was inundated with hints from all you *Pyjamarama* freaks out there.



- THE FANTASTIC FOUR ARE COMING!** 49
Yes, they're on their way — and you could win yourself a copy of their *Adventure Questprobe 3*, by Scott Adams!
- AMSTRAVAGANZA!**.....53
We proudly present a whole 12 pages devoted entirely to the Amstrad — news, reviews and an amazing *Sorcery* map.
- THE HOBBIT CONTEST**.....76
We've got 50 copies of the *Adventure* game plus the paperback to give away to those who can answer Bilbo's questions.

- CAULDRON COMPETITION**.....80
Wouldn't you like to win *The Golden Broomstick*? Be the envy of all your friends. Turn the page to find out how!
- BUG HUNTER**.....92
- MEGA HITS — SPECIAL OFFER**.....99
- ADVENTURE**.....106
Moves are afoot at Level 9 — in more ways than one! Plus details of *Amazon* from Telarium and *Suspect* from Infocom.
- ADVENTURE HELPLINE**.....108
- ADVENTURE REVIEWS**.....112
Our *Adventure* reviews are going to appear every month from now on — due to popular demand. There's service for you!



- SMARTY BERTY/BBC**.....34
Q Bert* with a difference! Tom Sato, our MSXpert, has had a bash at converting Bert to the Beeb.
- DOTMAN/AMSTRAD**.....66
Pac-Man lives again! But watch out for the spirits who didn't make it out of the maze.
- TANX 64/CBM 64**.....74
You are about to graduate from the army's crack tank regiment. To claim your red beret, though, you must complete this final gruelling test . . .
- PYRAMIDS OF AARON/ SPECTRUM**.....82
The legendary lost Pyramids of Aaron rise above you. You have heard that one of them contains the famed Aaron diamond. But will you succeed in finding it?
- DEFENDER/ VIC 20**.....90
Can you repel the advancing Aridis squadrons as they attempt to invade Earth in their search for a new home?

LISTINGS

NEWS AND REVIEWS

- GAMES NEWS**.....17
Urgent! Join our Bring Back the Doctor campaign now! There is no time to lose! Plus more juicy gossip from Tony Takoushi.
- REVIEWS**.....21/100
Firebird — alias British Telecom — certainly have hit the big time with *Gyron*, our Game of the Month. Plus many more star games for you to read about.
- ARCADE ACTION**.....94
This is obviously the month for champs! James Thomas, of *Juno First* fame, sets a new record on *Robotron* and Julian Rignall, our 1983 Arcade Champ, gives the game away on *Galaga*.
- NEXT MONTH**.....120



Game of the Month
Gyron

Spitfire

40

CHOCKS AWAY!

THE BEST THING SINCE THE REAL THING

A Spitfire flight simulation set in 1940. Ground features and realistic air combat.

Spitfire⁴⁰ is available from good software stores everywhere.



MIRRORSOFT

MIRRORSOFT, Mirror Group Newspapers Ltd

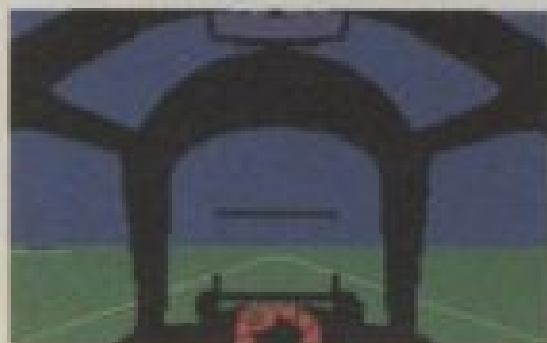

Holborn Circus, London EC1P 1DD Tel: 01-822 3580

A VERY SPECIAL COMPETITION

Target: To rise through the ranks of the RAF elite to Group Captain, VC, DSO, DFC

Reward: For the lucky few, a day out at the Battle of Britain Museum plus a test flight in a high performance aircraft. Details in every **Spitfire⁴⁰** pack

COMMODORE 64 (JOYSTICK ONLY)
DISK £12.95 CASSETTE £9.95



TOP SCORES FOR THE TEXAS

Dear Sir,
Two years ago I bought a TI-99/4A. At the same time TI announced they were ceasing production of the machine. But, as I knew nothing about computers and read no magazines, I had no idea of what was happening.

I bought a Texas because it was large, looked strong, robust and had a "proper keyboard". The shop assistant also told me that it had a lot of support — it did at the time and still has now.

But it was mostly the look of it that made me buy it. I refused to buy a "doorwedge" — Spectrum — and I refused to buy a "suitcase" CBM 64.

A few weeks later, after learning Basic fairly well, I bought several games written in basic on cassette. I thought they were great until I saw a Spectrum game. It was fast, exciting and most of all addictive!

After seeing the game, I thought up ways of selling my Texas and buying a Spectrum. But, as the days went by, I carried on playing basic games, reading *C&VG* and looking for the cheapest extended Basic I could find.

By this time, I was getting cheesed off and this Christmas I got cartridges instead of tapes. I got *Munchman* and *Buck Rogers* from Parco.

I popped in *Munchman* and I couldn't believe my eyes. The graphics were fantastic, the sound brilliant and the

addictiveness out of this world!

The maze is set out in 3D and there are different types of ghosts on each screen. This makes you want to keep playing the game and getting further to see different ghosts.

I now intend to purchase all the cartridges from Parco (gradually). Please print this letter in your magazine as not every Texas owner knows about these excellent games. Also, could you try and review more of the cartridges as you did with *Buck Rogers*? You gave it a score of 9 for everything. *A V Battle*

Preston

Editor's reply: Watch out for a Texas review special coming your way very soon!

FRANKIE REALLY IS THAT GOOD!

Dear Sir,
How can you doubt? I was shocked, terrified, amazed and depressed all at the same time when I read your article on *Frankie Goes To Hollywood* in the January issue. You wanted feedback about whether F.G.T.H. were THAT good.

I think *Frankie* is the most revolutionary band that has ever been seen or heard! They make THE music, no doubt about that. The only ones who disapprove are too conservative to see the fun.

Frankie's only mission is to shock the bourgeoisie, and they do that well. I believe it's a great idea to let bands make computer games. So RELAX — *Frankie* is the best! *Michael Steinmetz, Denmark.*

WHERE ARE ALL THE WOMEN THEN?

Dear Sir,
Over the last year I have become more and more disappointed by the lack of women in your Adventure pages and reviews pages. Are they all male reviewers? Are you all male chauvinists?

I think it is about time more women were encouraged to use computers, whether it is for pleasure or business. I for one enjoy playing Adventure games and I am good at them, if I might say so myself.

I enjoy your Adventure page very much and will continue to buy this magazine as it is good value for money. *Sandra L. Saunders, Suffolk.*

Editor's reply: What about our Arcade spy, Clare Edgeley, then Sandra? We would like to see more female interest in computers reflected in the magazine. How about it girls?

IMPOSSIBLE — NO! ELUSIVE — YES!

Dear Sir,
I am just writing to inform you that *Impossible Mission* by Epyx isn't. Impossible, I mean. After two-and-a-half hours of solid playing, I finally cornered the snivelling Elvin Atombender in his control room. Full marks go to Epyx, who have produced a game that has got everything: great speech, fantastic animation, a mindbending puzzle and that precious ingredient —

addictiveness.

There's only one criticism that I can think of: why is it so hard to obtain a copy of this game? I had to search for two months in all of the major retailers before I managed to track down a copy in Boots!

Am I the first person you know of who has achieved this major feat?

*Matthew Barratt
Bedfordshire.*

Editor's reply: Great stuff, Matthew! We haven't heard of anyone else completing the mission so you could well be the first. Why not give CBS a call and check it out?

TAKE CARE WITH COMPUTER CLUBS

Dear Sir,
I just thought I would write to inform your readers about a recent experience I had with one of the many computer hire clubs now in existence.

I ordered a cassette for my CBM 64 from MCL. When it arrived I tried to load it but could not. Even after cleaning and demagnetising the tape head, I still could not load it.

I returned the cassette the same day, and received a letter from MCL a couple of days after that. Their reply — a photo-copy letter — stated that the cassette had been tested and found to be working and put the blame on user error or magnetised tape heads.

As I have had no trouble loading any other program in my collection, I feel I have been ripped off, as the company said I could not have any alternative

Please drop us a line at: Computer & Video Games, Priory Court, 30-32 Farringdon Lane, London EC1R 3AU.



game or even credit.

At £1.75 per cassette for one week's hire, I feel disappointed at the company's response. Needless to say, I won't be ordering any more cassettes from them.

So remember, anyone thinking about joining a club with the top prices — you may not always be getting the top service.
*M Steele,
Liverpool.*

SAVE US FROM THE SHARKS!

Dear Sir,
I think your mag, is first class, but it could do with a column on sharks and how to watch out for them.

I have in the past been had, done, whatever you want to call it, by such people and I think your mag. could do a lot to help. We little people are conned by these sharks who are out to make a fast buck.

I think I would be right in saying that I am not alone — many people have had just such an experience. I for one have learned my lesson when buying programs and books for my TI-99/4a. So why not have a space set aside for just that? You could call it Micro Watchdog maybe!

I would also like to praise Parco Electrics. They not only have everything for the Texas but have a fantastic mag. that's a must for all Texas owners. Thanks, *C&VG*, for supporting the TI.
*W Fairbairn,
Fort William.*

Editor's reply: OK, Mr Fairbairn — and anyone else who has had

problems — send us details and we'll attempt to check them out. Can't say fairer than that, can we!

THREE CHEERS FOR THE ADVERTS

Dear Sir,
Having just read your February edition, I was annoyed to find Mr A. Haynes of Stoubridge saying that there were too many adverts. I personally think that advertising is a good idea because it shows you games which are up to date and shows you new games which have been brought out by new companies.

I first learnt about *Raid Over Moscow*, *F15 Eagle*, *Beachhead*, *Indiana Jones* and many more because of advertisements. It also gives you an idea of what they look like and tell you — sometimes — about them. I also find that they make good posters — especially the Ultimate ones.

I think that adverts make a good magazine and one of the reasons I changed my computer magazine to yours was because your advertising was good. A number of people agree with me and we are extremely pleased with the magazine. It is way ahead of any other. Keep it up!

*D.R. Hank,
Nr Stafford.*

WHAT ABOUT THE MTX THEN?

Dear Sir,
As a regular reader of *C&VG*, I want to say — WHEN is someone going to produce quality software for the Memotech MTX 500/512?

I'll remind you that the MTX series is WORTH the investment. It has sprite and hi-res graphics, a built in Z80 Assembler/Monitor, Basic and Noddy (for text applications), up to eight windows, 16 colours, three tone plus one noise sound capability and almost all of its 32k (64?) is available to the user and NOT gobbled up when using hi-res graphics because of its dedicated 16k video RAM. You can expand it to run CP/M and use up to 512k of RAM!

It's a disgrace for anyone to ignore a computer that offers so much. Please DO something about it!

I'll be buying the MTX 500 for £199 when I've saved up and I'm hoping that for Memotech users' sake there will be more support for it. Finally, I'd like to see more Texas reviews and programs. They've faded out since last October.

*P.J. Hutchison,
Mytholmroyd,
W. Yorks.*

Editor's reply: Continental Software, Unit 23, Station Lane, Witney, Oxon, make a huge range of games for the MTX, Mr Hutchison, and it might be worth your while to contact them. Their telephone number is 0993 5071.

ONCE A PIRATE ALWAYS A PIRATE

Dear Sir,
I don't know how many times I have either read or heard that "games are overpriced" and if the price of the game was lowered, this would cut down on piracy.

As a teacher at a school, I see pupils bringing in pirate copies of games.

Now it is fair to say that I tell them that what they are doing is illegal and immoral, but this does not stop them. They will take a copy of a friend's program no matter what the price is. To them it makes sense to copy a program rather than buy it even if it does only cost £1.99.

Copying by young users is done for one reason — to save money. The game is not pirated to sell, but to swap. If the small group of six people buy a game each and a blank tape each, they do a swap so that all six end up with the same games (they even went to the bother of copying out the *Jet Set Willy* colour card).

No game seems to be safe. They'll take a game like *Lords of Midnight* and copy it, make their own overlay and copy the relevant sections out of the booklet.

I must, therefore, disagree with one of your letter writers. The pirates copy a game because it's there. It is nice to get something for nothing, even if you are only saving 90p.

I think we've got to accept the fact that people are going to pirate games, no matter what the cost is. There are born pirates. I know. I've met them. Nothing I say will stop them.

Allow me to put in one last thought. If the software houses assume that games are going to be copied, maybe they "overprice" the games (I don't really think I can say whether a game is overpriced or not) to recover some of the money they expect to lose. It's a thought, isn't it!
*John McLean,
Kirkcaldy,
Fife.*

Please drop us a line at: Computer & Video Games, Priory Court, 30-32 Farringdon Lane, London EC1R 3AU.

AMSTRAD 16:95

ZX SPECTRUM 16:95

COMMODORE 64 17:95

WORLD SERIES BASEBALL



Imagine Software is available from:

WOOLWORTH, WHSMITH, **John Menzies**, LASKYS, Rumbelows, **COMET**, GREENS,
Spectrum Shops and all good dealers.

This is it! The ultimate *Alien-8* map! It's a screen-by-screen breakdown of the latest instant classic from Ultimate Play the Game — just as you see it as you play. *C&VG* has teamed up with Dimension Graphics to produce this impressive guide to the game. Dimension use sophisticated printing techniques to transfer computer graphics to paper — and you've probably already noticed examples of this technique on our Reviews pages. This is a first for *C&VG* — and we hope you like it! Many of our regular readers have sent us maps which we've used to help put our screen by screen guide together. Our thanks to everyone who sent a map in. Games playing tips also came our way — and we've enlisted the help of Professor Video's top student, Aonghus de Barra from Dublin, and Timothy and James Closs from Shepperton to bring you hints on how to get the best out of the game . . .

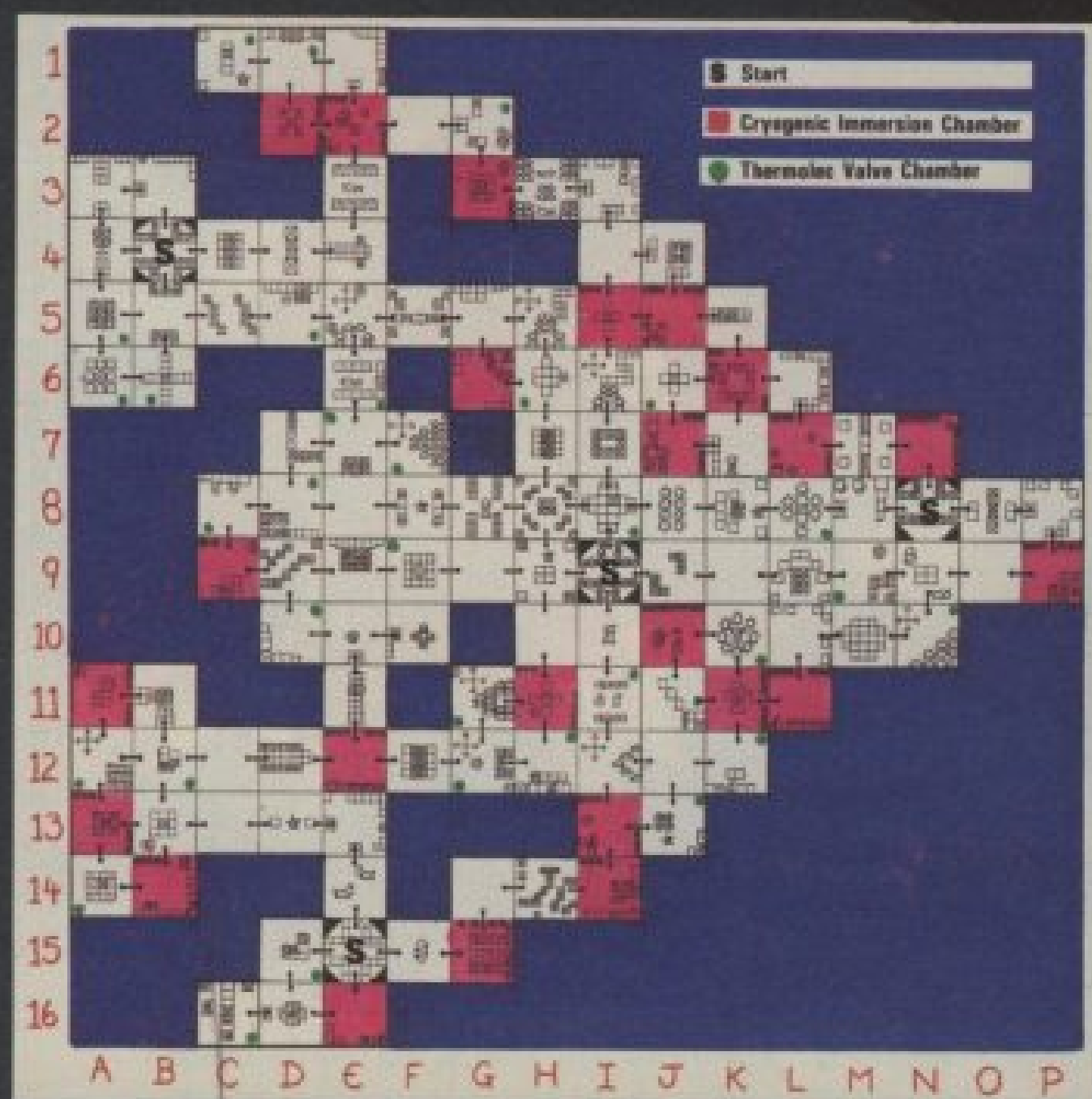
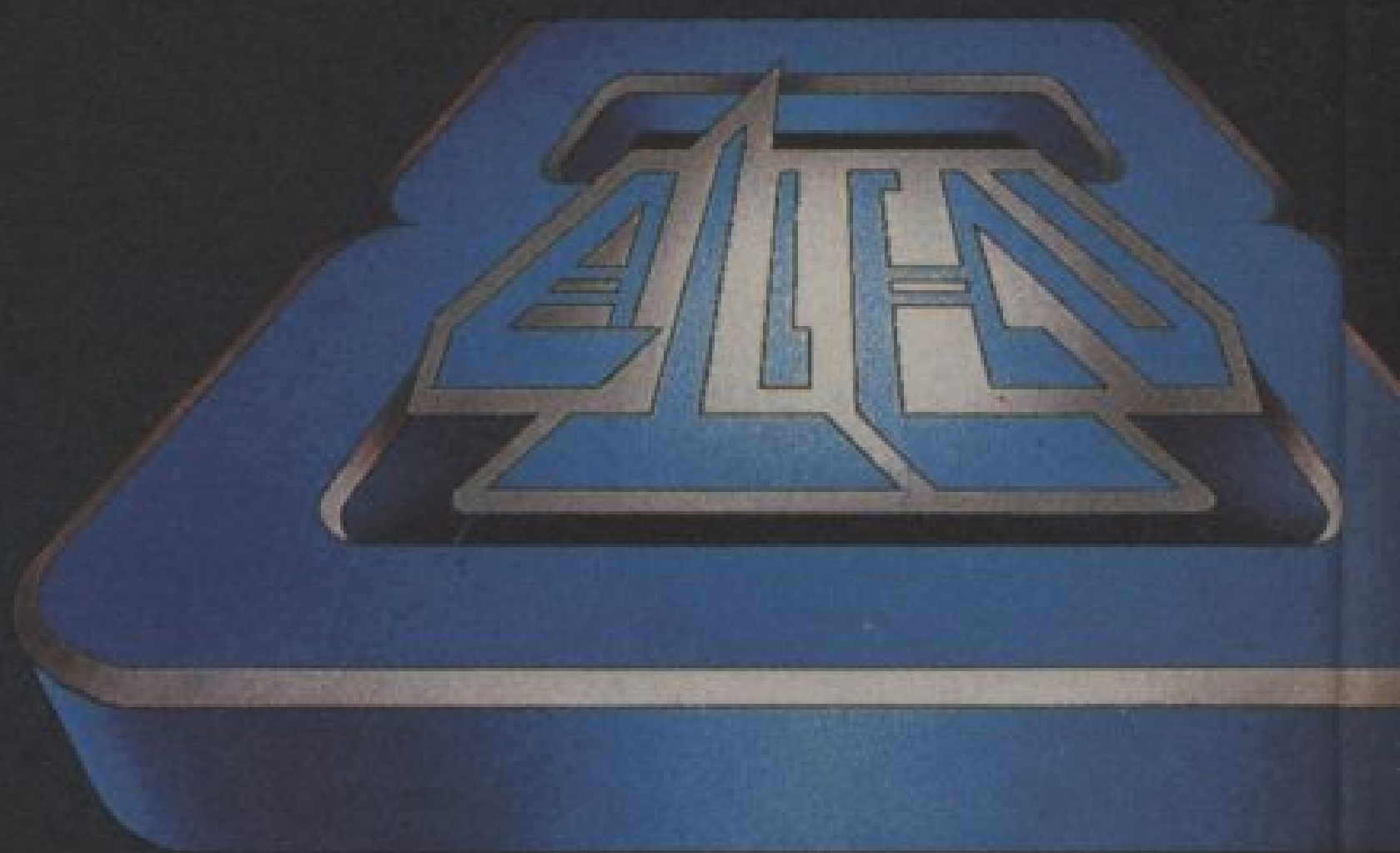

ALIEN 8

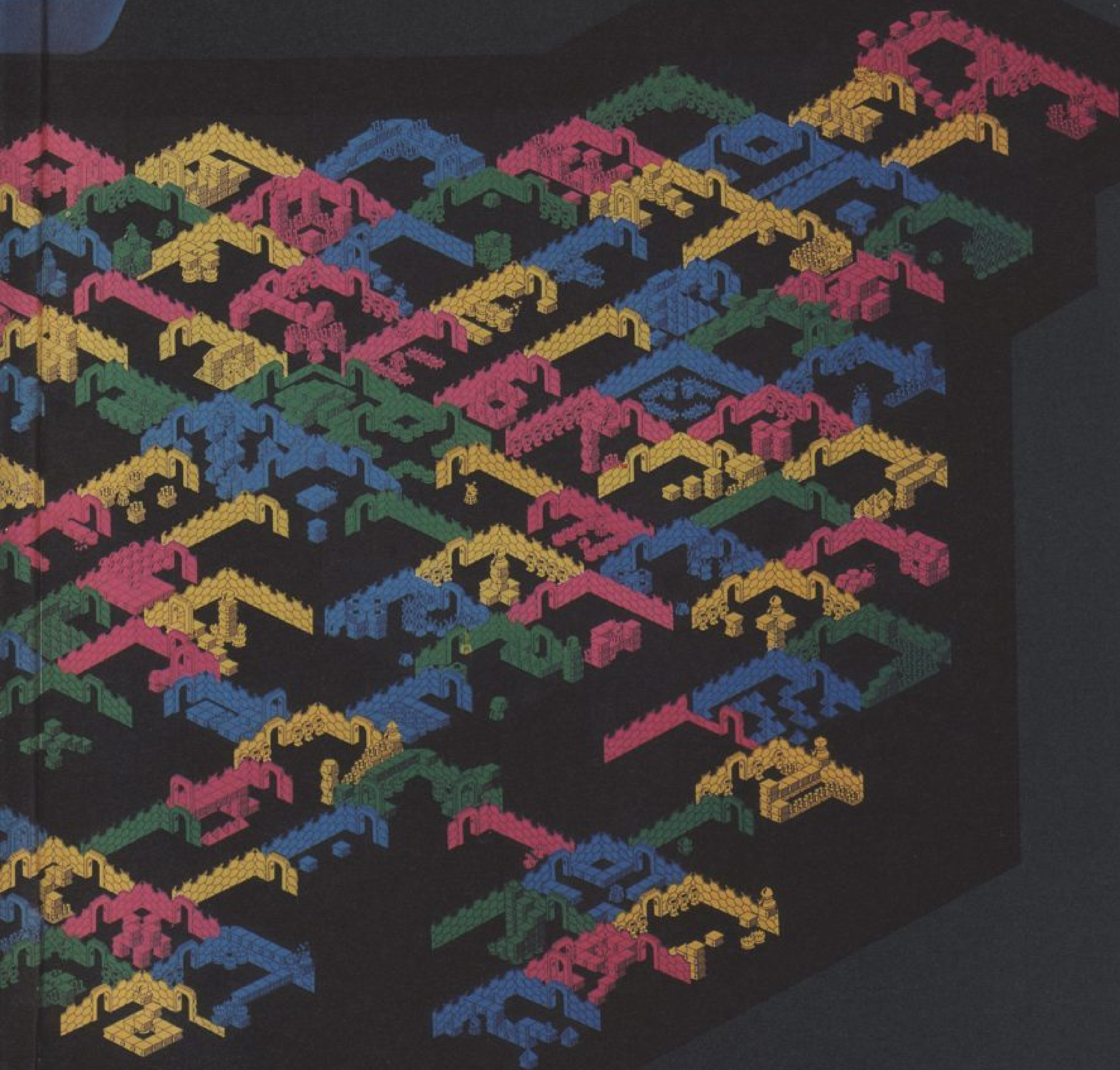

GATES OF DAWN

...A STEP OVER THE THRESHOLD

For time immemorial man has been challenged by the mystery of his dreams. Deep within each dream lies an enigma as yet unsolved. Go now through the Gates of Dawn and experience the recreation of the surreal world of dreams in this vibrant arcade adventure. Enter these portals and lose yourself in a dazzling and perplexing world where nothing is too fantastic.

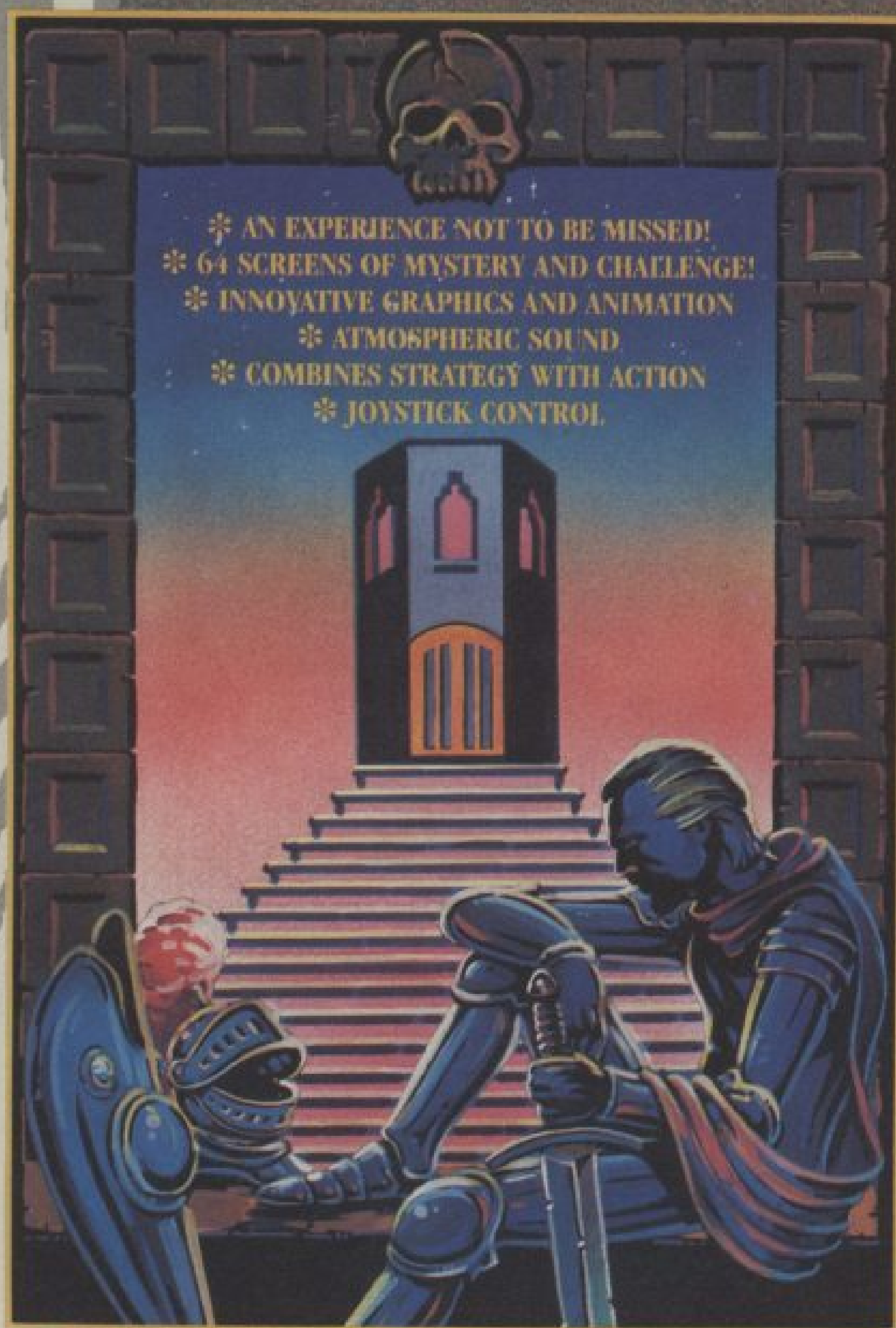

- * AN EXPERIENCE NOT TO BE MISSED!
- * 64 SCREENS OF MYSTERY AND CHALLENGE!
- * INNOVATIVE GRAPHICS AND ANIMATION
- * ATMOSPHERIC SOUND
- * COMBINES STRATEGY WITH ACTION
- * JOYSTICK CONTROL.

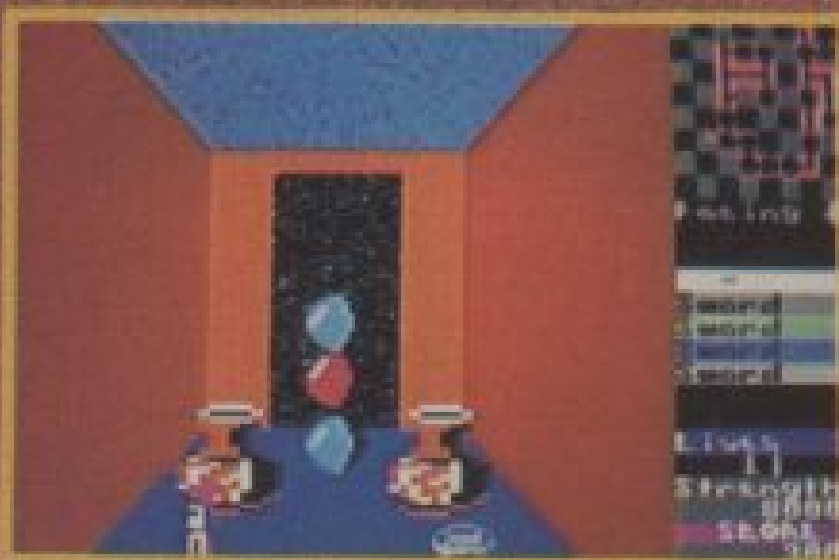
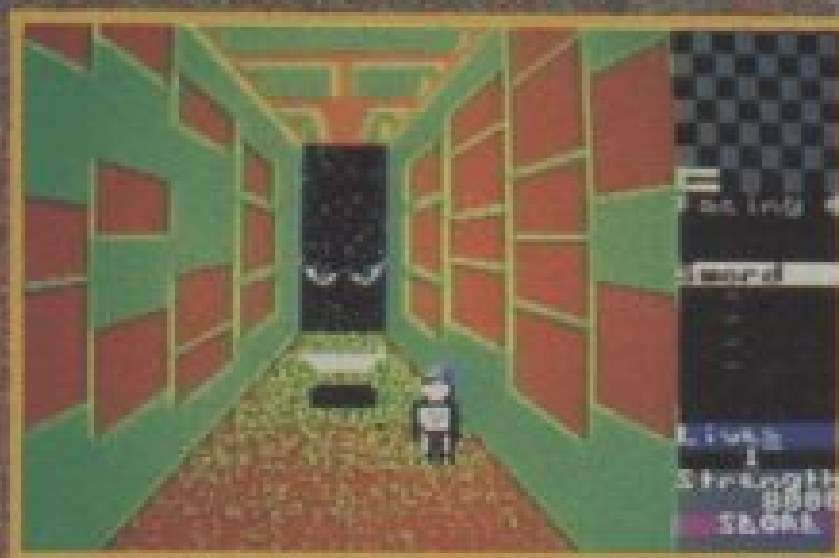

SO PREPARE YOURSELF FOR A SUBLIMINAL EXPERIENCE

*Gates of Dawn is available for the Commodore 64
from all good software retail outlets from 15th April.*

R.R.P. £8.95 CBM 64

*Also available from Virgin Games Limited, 2-4 Vernon Yard, 119 Portobello Road,
London W11 2DX. Telephone: 01-727 8070*



GOOD BYTE

SPECTRUM

GAME	RRP	OUR PRICE
GOODDARK'S REVENGE	9.95	6.95
GYRON	9.95	7.95
ZAKXON	7.95	5.95
DALEY THOMPSON DECATHLON	6.90	4.90
LORDS OF MIDNIGHT	9.95	6.95
BACKPACKERS GUIDE	7.50	5.25
GHOSTBUSTERS	9.95	7.75
SABRE WULF	9.95	6.95
UNDERWORLD	9.95	6.95
KNIGHT LORE	9.95	6.95
TIR NA NOG	9.95	6.95
PSYTRON	7.95	5.95
AIR WULF	6.90	5.20
MATCH DAY	7.95	5.20
PIJAMARAMA	6.95	5.20
SCHLODIAZI	5.95	4.75
GLASIMODOS REVENGE	6.90	4.90
JET SET WILLY	5.95	4.75
KOKOTONI WLF	5.95	4.75
COMBAT LYNX	7.95	5.25
ENDURO	7.95	5.50
AVALON	7.95	5.50
T.L.L.	5.95	4.60
KING DOCK HDKMS	14.95	10.50
WHITE LIGHTNING	14.95	10.50
SEACHHEAD	7.95	5.95
ZAKXON	7.95	5.95
CYCLONE	5.95	4.75
3D STAR STRIKE	5.50	4.75
RAM TURBO INTERFACE	22.95	18.00
FIGHTER PILOT	7.95	5.95
KONG STRIKES BACK	6.90	5.20
GIFT OF THE GODS	9.95	7.25
TECHNICIAN TED	6.95	5.25
ALIEN 8	9.95	7.25
PROJECT FUTURE	6.95	5.25
BRUCE LEE	7.95	5.95
EVERYONE'S A WALLY	9.95	7.50
VALHALLA	14.95	10.50
TAPER	7.95	5.50
SPY HUNTER	7.95	5.50
EMERALD ISLE	6.95	5.50
NIGHT GUNNER	6.95	5.50
BRIAN BLOODAXE	6.95	5.50
RAID OVER MOSCOW	7.95	5.50
MEGA HITS	19.95	14.00
WORLD SERIES BASEBALL	6.95	5.25
SHADOW FIRE	9.95	6.75
A DAY IN THE LIFE	6.95	5.25
DRAGONFORC	7.95	5.95
GRAND NATIONAL	6.95	5.25
WIZARDS LAIR	6.95	5.25
DUKES OF HAZZARD	6.95	5.25
TALISMAN	7.95	5.95
KEY OF HOPE	7.95	5.95
SPY VS SPY	9.95	6.75
MOON CRESTA	6.95	5.25
CONFUSION	6.95	5.25
DEATH STAR INTERCEPTOR	7.95	5.95
MINI OFFICE	5.95	4.50
BRIAN JACKS	7.95	5.95
SUPER PIPELINE II	8.95	6.75
HERBERTS DUMMY RUN	9.95	7.50
STARION	7.95	5.95
CHAOS	7.95	5.95

Overseas orders welcome - add £1.50

ALL PRICES INCLUDE P&P
 QUICKSHOT II ONLY £8.99
 PLEASE NOTE IF YOUR ORDER
 EXCEEDS £50 YOU GET
 10% FURTHER DISCOUNT
 SEND CHECKS/POSTAL ORDER TO
 GOODBYTE, 84 LEATHER LANE
 LONDON EC1 Tel: 01-484 4245
 PLEASE STATE WHICH MICRO

COMMODORE 64

GAME	RRP	OUR PRICE
WORLD SERIES BASEBALL	7.90	5.90
BREAK FEVER	7.00	4.95
CADACAM WARRIOR	8.95	7.50
PSI WARRIOR	9.95	4.95
SUICIDE EXPRESS	7.95	6.50
GHOSTBUSTERS	10.95	8.50
PSYTRON 64	7.95	5.50
SPY VS SPY	9.95	6.95
NY CHESS II	11.95	7.25
TALES OF ARABIAN NIGHTS	7.00	3.75
BRUCE LEE	9.95	7.25
BATTLE FOR MIDWAY	9.95	4.95
QUASIMODOS REVENGE	7.90	5.90
KONG STRIKES BACK	7.90	5.90
SUMMER GAMES	14.95	10.50
SHERLOCK	14.95	10.50
STORM WARRIOR	8.95	4.95
STAFF OF KARNATH	9.95	7.50
DEATH STAR INTERCEPTOR	9.95	8.00
KOKOTONI WLF	6.90	5.25
SELECT 1	12.49	8.49
COMBAT LYNX	8.95	7.25
EMERALD ISLE	5.95	5.50
ELITE (Mk II) (3D 4.85)	14.95	11.50
SHADOW FIRE	9.95	6.75
GRAND NATIONAL	7.95	5.95
CYPHOID 9	5.95	7.50
AIR WULF	7.95	5.95
AQUA RACER	7.95	5.95
SHADES	8.95	5.75
MEGA HITS	19.95	14.50
TIR NA NOG	9.95	7.50
HOBBIT DISC	17.95	13.50
IMPOSSIBLE MISSION	8.95	6.75
SLAP SHOT	8.95	6.75
MOON CRESTA	7.95	5.95
BRIAN JACKS	8.95	6.75
EVERYONE'S A WALLY	9.95	7.50
SUPER PIPELINE 9	9.95	7.50
HERBERTS DUMMY RUN	9.95	7.50
MINI OFFICE	5.95	4.50
LORDS OF MIDNIGHT	9.95	7.50
THEMATE EUROPE	9.95	7.50
BLAGGER GOES TO EUROPE	7.95	5.95

AMSTRAD

GAME	RRP	OUR PRICE
SOURCERY	7.95	5.95
DALEY THOMPSON	8.95	6.75
FIGHTER PILOT	8.95	6.75
MINI OFFICE	5.95	4.50
DARK STAR	7.95	5.95
JET SET WILLY	7.95	5.95
FOREST AT WORLDS END	14.95	11.50
HOBBIT	17.95	13.50
CHOPPER SQUAD	6.00	4.50
HEROES OF KAHN	6.00	4.50
JEWELS OF BABYLON	6.00	4.50
BATTLE FOR MIDWAY	9.95	7.50
COMBAT LYNX	8.95	6.75
QUASIMODOS REVENGE	8.95	6.75
KONG STRIKES BACK	8.95	6.75
BRIAN JACKS	7.95	5.95

BBC/ELECTRON

GAME	RRP	OUR PRICE
COMBAT LYNX	7.95	5.95
TALES OF ARABIAN NIGHTS	7.00	5.95
MINI OFFICE	5.95	4.50
MICRO OLYMPIKS	5.95	4.50
CASTLE QUEST (BBC ONLY)	12.95	9.50
SABRE WULF (BBC ONLY)	9.95	7.50
BRIAN JACKS	7.95	5.95

RAM MAKE MORE OF YOUR SPECTRUM...

Two great new add-ons to boost the power of your Spectrum (and Spectrum Plus).

The Ram Interface Mk.II is Kempston compatible. It lets you get the best out of your action games, with all the best joysticks around - even the Quickshot II rapid fire joystick. Electrify your enemies, with real power and lightning-fast reactions at your fingertips.

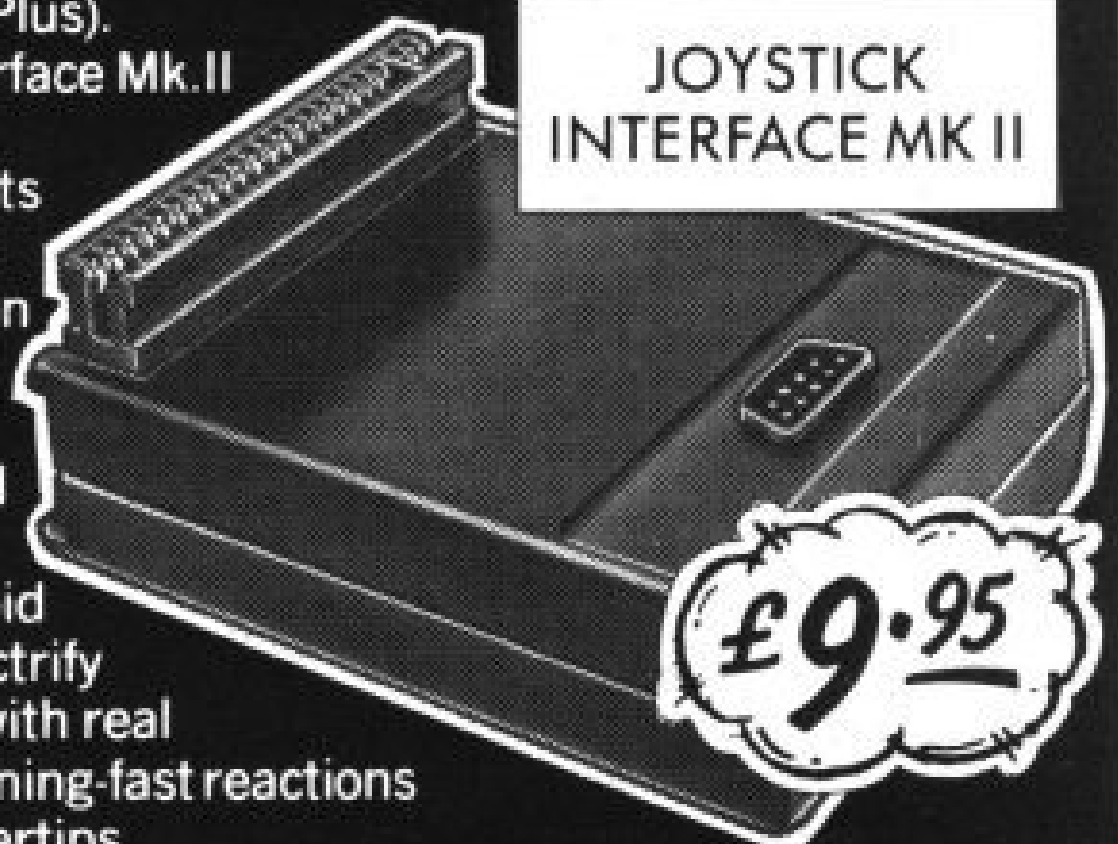

JOYSTICK INTERFACE MK II

£9.95

£21.95

Then there's our Spectrum Upgrade Kit. Boost your 16K memory to a fantastic 48K and run all the latest superb action software.

SPECTRUM UPGRADE KIT

...FOR LESS.

(Both Ram products are made to last. And fully guaranteed.)
 Get some real action into your Spectrum Games today!
 Simply return the coupon below to Ram Electronics (Fleet) Ltd., Dept. CVG, 106 Fleet Road, Fleet, Hampshire GU13 8PA. Or call our credit card hot line on 02514 25252.

Please send me
 Spectrum Joystick Mk.II Interface(s) at £9.95.
 Quickshot II rapid fire joystick(s) at £9.95.
 (only when purchased with interface. Normally £12.95)
 Spectrum Upgrade Kit(s) at £21.95.
 Please state issue 2 or 3
 (Please add £1 p+p for UK orders. £3 p+p for Europe)
 I enclose cheque/postal order, or charge my Access/Visa for £.....
 Name
 Address
 Telephone
 Postcode
 Expiry date
 To Dept. CVG, Ram Electronics (Fleet) Ltd.
 106 Fleet Road, Fleet, Hampshire GU13 8PA.
 Trade and export enquiries welcome.

ATARI 400/600/800/800XL

Why not compliment the greatest home computer on the market by obtaining membership with **MIDLAND GAMES LIBRARY**.
 The greatest, biggest and best Atari library on the market.
 An ideal present for old and new Atari owners.
MIDLANDS GAMES LIBRARY: The company who over 2 years ago, first conceived the idea of a software library.
 Now approaching nearly 1,000 titles on disc, cassette and Ram (games, business, educational and utilities). Often purchasing popular programmes 5 or 6 to give all our members a fair change. Always adding approximately 40 new programmes monthly.
 Over 1,000 very satisfied members, many as far away as Iceland, Sweden, West Germany, Holland, Denmark and Eire.
 A fast, efficient and friendly service. Requests are attended to immediately virtually assuring you a 24 hour return of service. Regular newsletters and programme updates, plus other inter-club activities. Now introducing original software written by existing members. Send large s.a.e. to:

MIDLAND GAMES LIBRARY
 48 Redway, Bishops Cleeve, Cheltenham, Glos.
 Tel: 0242-67-4960 9.30-4.30
 All our programmes are originals with full documentation

**COMPUTER & VIDEO
 GAMES
 ABC FIGURE JULY-DEC
 1984
 95,247**

First find yourself on the map. As with *Knight Lore* you begin each game from a different location. Use a small marker or counter to mark your starting point. The random starting points are marked on the map with an S.

When entering a room be careful, and use the pause button to plan your moves if there is an alien or Cyberat in the room.

In some rooms you will find a group of blocks with arrows on them, together with one or two Robodroids. Jumping onto a block will make the Robodroids move in the corresponding direction. Using this technique you can move any obstacles using the Robodroids — clearing exits, moving dangerous objects etc. Where there are two Robodroids, one will be controlled until you jump off the blocks — the other will come under your control when you jump on to another arrow block.

In one room the exit is blocked by a double row of obstacles. The Robodroid can only destroy the bottom ones — so what do you do? Simple. Just put one of the valves you are carrying onto the droid then begin to control him — this way you destroy both top and bottom obstacles.

Those of you who are really new to this sort of game might like to know that you can jump higher by standing on an object you are carrying. But remember to press the "pick-up" key at the same time as "jump" so you take the object with you.

If you are not carrying anything, here's how to cross obstacles which are just one block high. Walk as close as you can to the obstacle then turn right around and walk one space back.

Turn to face the obstacle again and press the "jump" key — and keep it pressed, otherwise you won't make it!

In one room there is a "hidden circuit". This means the control blocks are hidden underneath a tower of disappearing blocks which must be destroyed if you wish to control the robot.

If the right valve is dropped in a cryogenic chamber, it

will move towards the socket. In some chambers this can be used to your advantage — drop the valve and let it carry you to the socket!

In the cryogenic chambers where fatal objects are suspended from the roof, make sure you drop no valve other than the right one, as this will result in the objects falling down on top of you.

Space dust often needs to be jumped on if a valve is to be reached. By dropping a valve on top of the space dust and standing on top of it, the dust can be controlled

to go wherever you want it to!

Cyberats are a pain unless you know how to get past them, so read on. As soon as you enter the room, drop and stand on a valve. The Cyberats may push you around, but shouldn't kill you. When you see a space in front of you, pick up the valve again. Repeat this procedure until you reach the exit.

To pass a Plasmic Usher safely, run right up to it before jumping as far as possible.

How to use the valve table:

There are 33 valves scattered throughout the starship. A valve can always be found in the same room, although the shape of the valve changes for each play. The table shows that valve rooms are grouped in four sets — three with 8 valves and one with 9. Depending on which valve you find first, it is possible to deduce in which rooms other valves can be found. For example, if you found a cube in M9, you find a hemisphere in G2 and a pyramid in K10, as you would be playing with sequence four.

ALIEN 8 PLAYING TIPS

B13 — The object lies underneath the centre blocks, but before it can be picked up two moveable blocks must be shifted. To avoid losing a life, the object should be moved from under the blocks before being picked up, as the upturned egg shell will fall when the object is taken.

C9 — The block in this room is presumably a red herring as the Life Support Socket can be reached by walking under the arch.

F9 — Push the object off the blocks before you pick it up as the egg shells surround and kill you when you pick it up.

F15/N9 — To avoid the intelligent object, it often helps if you go to one side of him, then double back and go round the other side. This has the effect of fooling him into thinking you are going a different way to the one you are.

H14 — Using your object to jump over the pyramids, take the route around the outside right of the room. It is easier and quicker than taking the intended route.

J4 — Got to the protruding block of the platform you are on, and jump onto the block amongst the egg shells. This will then rise to the level of the other door.

L9 — There is no need to turn at all here. Simply jump onto the block immediately in front of you, do a short jump onto the next and then a long jump should see you on the other side of the room.

VALVE TABLE

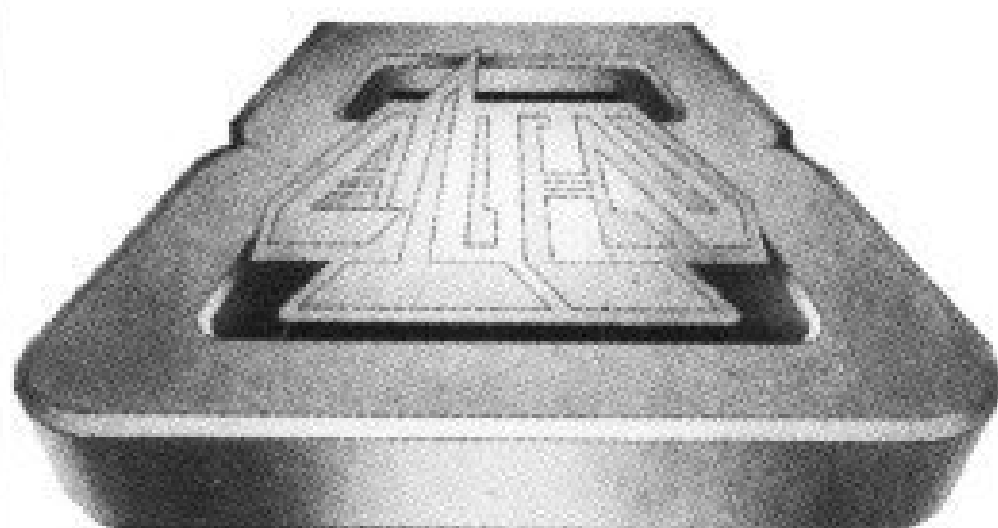

	D1	A6	J6	C1
	G11	L8	K12	E6
	I8	C16	H6	N10
	D15	J11	D8	D5
	J13	F7	C8	A14
	M9	D10	E7	G12
	F9	B12	A5	K10
	A12	H12	B6	I11
			G2	
PYRAMID	1	2	3	4
CUBE	4	1	2	3
CYLINDER	3	4	1	2
HEMISPHERE	2	3	4	1

PALACE SOFTWARE PROUDLY PRESENTS

CAULDRON



SCREEN-SHOTS FROM THE COMMODORE VERSION.



A spectacular new arcade adventure game from Palace Software that sets a new standard in graphic realism.

Commodore 64 and 48K Spectrum. £7.99.

“... will be one of THE games of 1985 ...”

This one is HOT so don't miss it! BIG K

Explore an entire world in 'Cauldron' – The first game ever to feature scrolling shoot-'em-up and platform jumping.

Available from all good Computer Games Shops or direct from Palace Software, 275 Pentonville Road, London N1 9NL.

Dear Palace Software,
Please send me the following cassette(s):-

- Cauldron (CBM 64) @£7.99
- Cauldron (Spectrum) @£7.99
- Evil Dead (CBM 64) @£6.99
- Evil Dead (BBC) @£7.99
- Valkyrie 17 (CBM 64) @£9.99
- Valkyrie 17 (Spectrum) @£9.99

Please add 80p P&P to your order. Payment by cheque to Palace Software, Postal Order or by Access/Barclaycard No. _____

Name: _____

Address: _____

Postal Code _____



PALACE software

Instead of computers catching technology now has to catch



The way we see it, technology has suddenly got quite a race on its hands.

There's no other home computer in the world that's so expandable or so updatable as the new Enterprise 64.

And if you're wondering quite how we've managed that, kindly take a closer look at the outputs on our remarkable new machine.

You'll notice that amongst all the usual sockets and terminals, we've gone and incorporated a special 66-way expansion port.

This will accept a whole range of new peripherals that are in the pipeline. Including those that are a mere twinkle in the eyes of our hardware designers.

We thought this expandability principle was such a good idea, we applied it to the Enterprise's memory, too.

Even in its most basic 64K form, this puts more user RAM at your disposal than almost any other competitor.

But plug in our special Rampacks to the base unit, and you can progressively increase that figure to a truly extraordinary 3,900K.

atching up with technology, atch up with a computer.

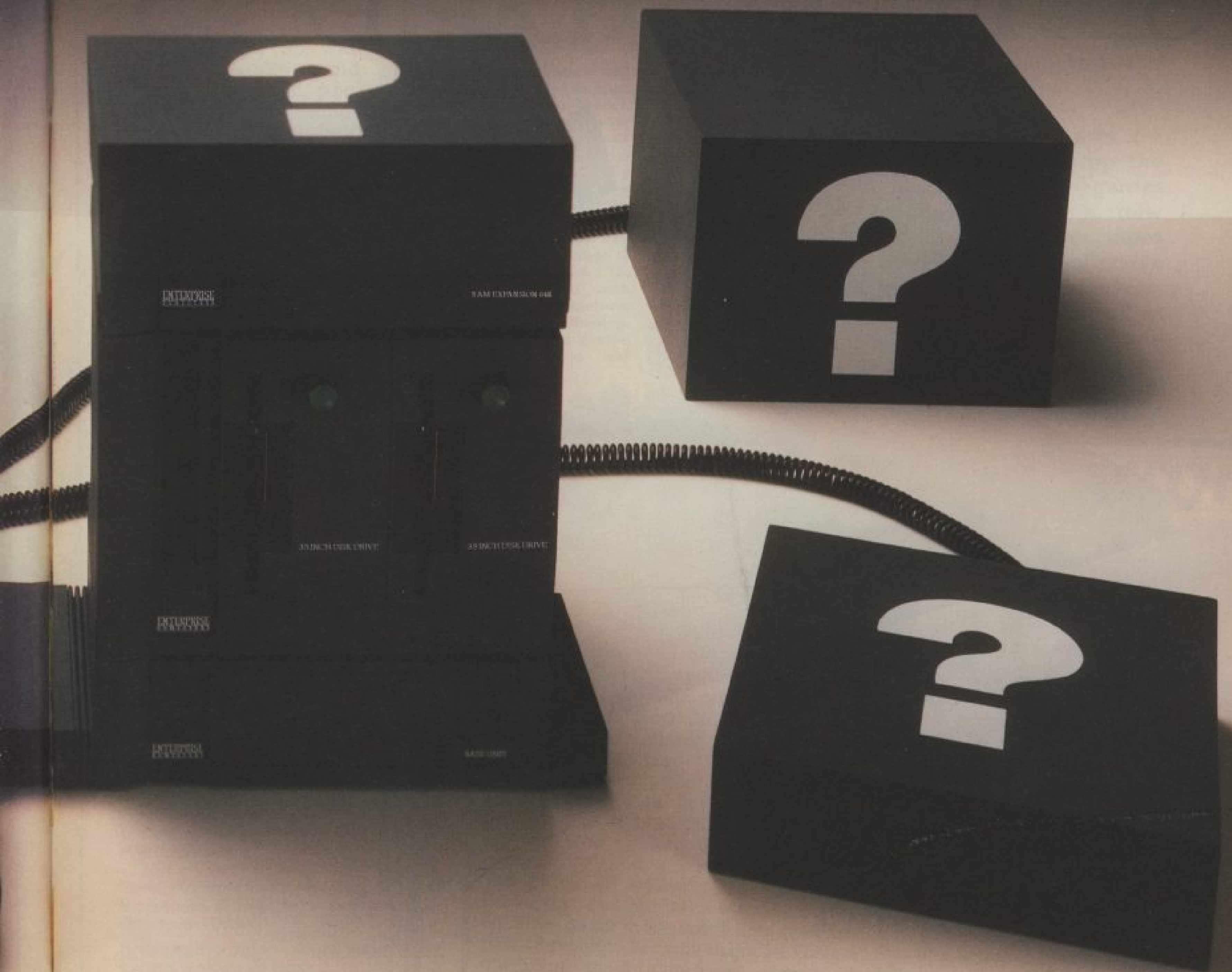

Not that that's the only challenge we present to today's ambitious programmers.

With a screen resolution of up to 672 x 512 pixels, 256 colours and a high speed video processor, the Enterprise will outgun all but the highest quality TV monitors.

And the sophisticated sound chip generates no fewer than 4 voices across 8 octaves in full stereo.

Combine the two and you can create effects that leave today's games looking like pub video tennis of the mid-seventies.

For anyone with literary aspirations, the Enterprise also comes complete with an integrated word processor.

Whilst the really serious user will be delighted to

discover analogue RGB and TV outputs, as well as parallel, RS423 serial and network ports.

Both Cobol and 'C' will be available with CP/M running, and you can even use Lisp, Forth and Z80 assembly language on cartridge without encroaching on user RAM.

The new Enterprise 64.

It hasn't just overtaken technology. It's left every other home computer straggling in the distance.

ENTERPRISE
COMPUTERS

WITH OBSOLESCENCE BUILT-OUT



S H A D E S

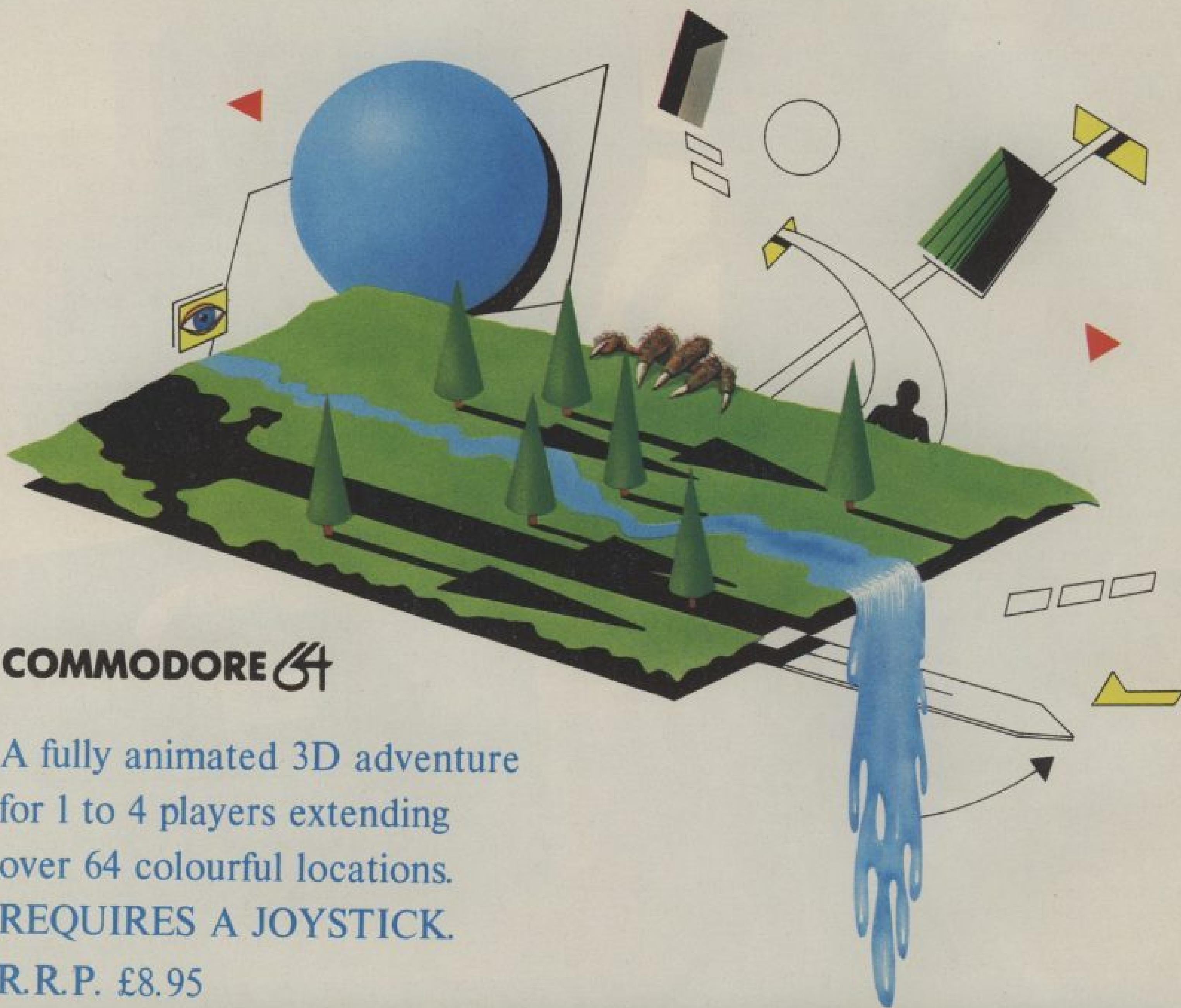

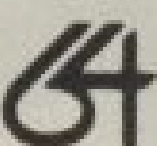
COMMODORE 

A fully animated 3D adventure
for 1 to 4 players extending
over 64 colourful locations.
REQUIRES A JOYSTICK.
R.R.P. £8.95



DURELL sales dept.,
Castle Lodge, Castle Green, Taunton, Somerset, TA1 4AB

G·A·M·E·S N·E·W·S

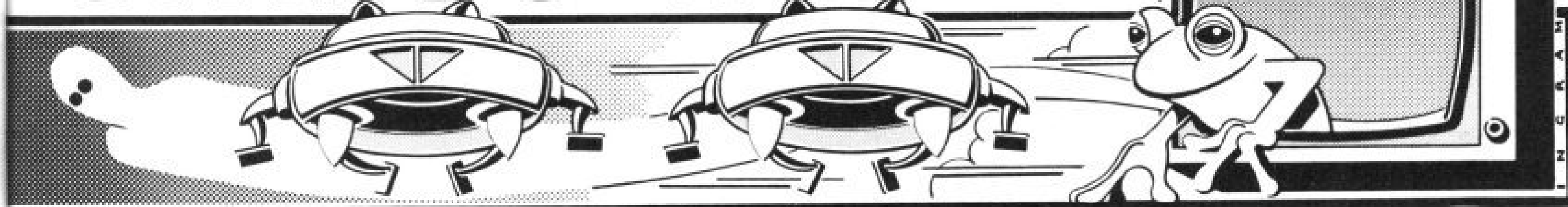

● Bored with plodding through the games listings in *C&VG*? Fed up with making mistakes and having to start programming in the listings all over again? Well help is at hand. If you own a Micronet modem, you'll be able to download programs for the Spectrum and BBC and — hopefully soon — for the CBM 64 direct from the Micronet 8000 system.

As from this issue, the programs we feature for these machines will be going onto Micronet.

★ ★ ★

SAVE DR WHO!

So the BBC reckon that they can get away with removing *Dr Who* from our screens, do they! Well, here at *C&VG* we're sure that many of our readers will be as upset as us at the news of the good Doctor's banishment from the airwaves. Has The Master finally found a way to get at our hero by taking on the appearance of a BBC executive? In any event, we're sure that you will want to join with all the rest of the Time Lords in an appeal to the Beeb not to get rid of our hero and support *C&VG's* Bring Back the Doctor campaign.

All we want you to do is put your name and address on the coupon below — send it to use at *Computer & Video Games*, Bring Back the Doctor, Priory Court, 30-32 Farringdon Lane, London EC1R 3AU — and we'll pass your protests on to the powers that be at the BBC. You can also get a friend to sign using the second coupon!

Come on, don't let the Beeb do what the Daleks, Cybermen, Ice Warriors and The Master have all failed to do over the years. Write to us TODAY!

COMPUTER & VIDEO GAMES BRING BACK THE DOCTOR CAMPAIGN

Name.....

Address.....

Signature.....

Name.....

Address.....

Signature.....

I·N·B·R·I·E·F

● Is it a bird? Is it a Sinclair C5? No it's SUPER GRAN! Yes that OAP with super powers will soon be coming to save the computer gamers of the world! Tynesoft have signed a deal with Tyne Tees TV to make the extremely popular granny the star of a computer game which will be released on April 2nd. The game — which Tynesoft say is like five original games in one package — will initially run on the C64, C16, Spectrum and Amstrad with versions for the BBC, Electron, Atari and Einstein following. *C&VG* will be running a special Super Gran competition next issue — don't miss it!

★ ★ ★

● The *C&VG/Computer Trade Weekly Auction and Sale* in aid of Ethiopia will be held on Saturday June 15 at County Hall, with various celebrities, singers and representatives from the home computer industry expected to attend. We want you lot out there to come and join us! Bring along any computer-related pro-

ducts you don't want so we can add them to the sale, or send them direct to us here at the office.

★ ★ ★

● **Creative Sparks** are all set to light up the pocket-money games market with a new range of games tapes under the collective name of Sparklers. The games will sell at £2.50 and will cover all the popular home computer. Titles will be announced soon.

DESIGNER OF THE MONTH

NAME: Stephen Redman

BORN: Sunderland, 1964

GAME: Day in the Life

Mild-mannered Stephen Redman has gone right for the throat of the computer business with his first ever game — based on a day in the life of the man who could be said to have started the whole thing off, Sir Clive Sinclair.

You can read about the game elsewhere in this issue. But now read about the 21-year old student of computer science who created this controversial game.

Stephen is studying at Newcastle University, and has been working on the Sir Clive game in his spare time over the past 18 months. But why make Sir Clive a character in a computer game? "I needed a character and he fitted the bill!" says Stephen.

He approached Micromega, the people behind *Code Name Mat* and *Jasper!*, with the game and they were quick to realise a good game when they saw one!

It was after meetings with the people at Micromega that Stephen came up with the general theme of the game. You take Sir Clive through the day in which he has a very important appointment with a very important person at Buckingham Palace. He even managed to squeeze in a C5 at the last minute! "I got a lot of help from



my flatmates in Newcastle — all of them are into computers."

Stephen intends to follow a career in computing — with games continuing as a hobby. "We'll just have to wait and see what happens," he says.

In the meantime, anyone who can get Stephen a ticket for the Milk Cup final, when Sunderland take on Norwich, can be assured of a few good hints and tips on *Day in the Life!*

Favourite Food: Gold old English grub!
Favourite Drink: McEwan's Eighty Shillings

Favourite TV Programme: Hill Street Blues

Favourite Computer Game: Match Day from Ocean

Countries visited: France
Favourite Music: Dire Straits, Joan Armatrading

The thing I hate most about the computer industry: Acorn Computers!

H-O-T G-O-S-S-I-P

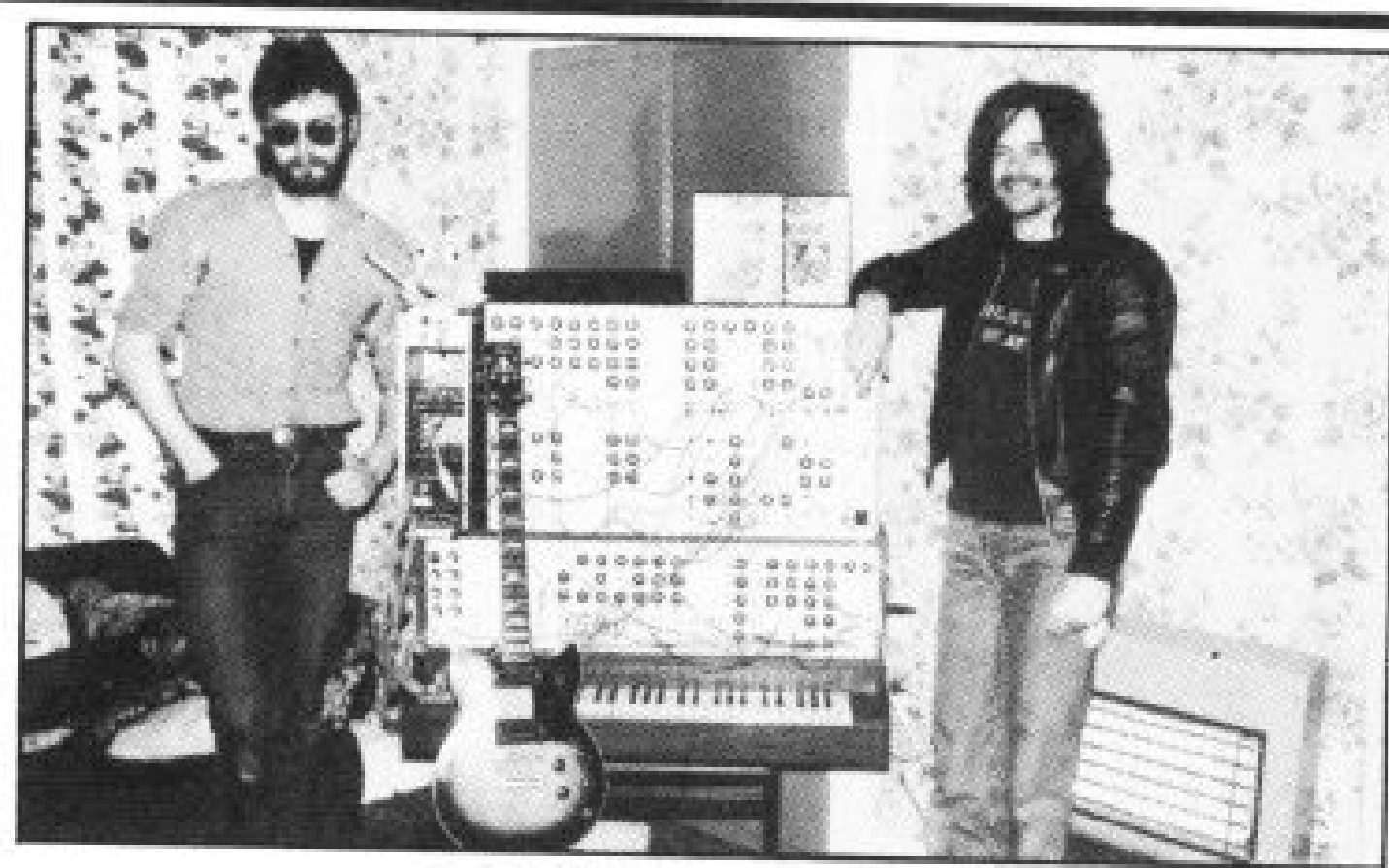

GIBBO!

Tony Gibson alias Gibbo — age 37 — has been writing games for four years. He helped write *The Pit*, *Wizz*, and *Pipeline* for the arcade market and then devised and programmed *Jammin'*, *Bozo's Night Out* and *Seaside Special* for Taskset. After learning electronics at Skillcentre, he built Synthia 2, a micro music synth. He played one gig with Eileen's Tea Towel when the computer packed up — so he decided to write rock 'n roll games instead! Now he uses Synthia to develop music for games. Gibbo is a motown, soul and reggae fanatic.

Mark Harrison, age 32, met Gibbo at the ill fated gig. He plays ace lead guitar in a

local R'n'B band, Generator. He designed graphics for *Bozo* and *Seaside Special* as a hobby — and hopes soon to set up as a freelance graphics artist. He also arranged the music for *Jammin'*.

Mark is married with three children — Matt aged 10 (top games tester), Anna aged 7 and Lee aged 3 months, who has yet to nail his first space invader.

Ghettoblaster is the first real computer rock musical and the pair intend to produce more software of this type, as well as some games and a special super secret project which is expected to be finished in September.

PETALS OF DOOM



There were two new inspiring rewrite of the Commodore 16 games I first) received this month from It is a cross between Gremlin Graphics, *Jet Pac* and a scaled *Petals of Doom* and down version of *Tycoon Tex*. Of the two, *Defender*. The graphics *Petals of Doom* was are good and the use of clearly the better colour reasonable but it (*Tycoon Tex* being a non-lacked a little in terms of

GET ON DOWN WITH GHETTOBLASTER

"Allo dere, de name is Rodney and I's gotta get de tapes from all de funkier mix masters in Funkytown. When I's got dem tapes, dey gotta be deievered to de Interdeesc Studio."

Tony Gibbons assures me that the above (albeit brief!) description is the basis for his new game called *Ghettoblaster*.

Ghettoblaster has you travelling around the town's 250 screen locations picking up the tapes and delivering them safely to Interdisc offices. There are ten tapes in all to collect with the last tape in Itchycoo Park (I'll let YOU puzzle this one out).

To help you along the way, you have a ghetto-blaster hoisted on your

shoulder blaring out music (as long as you have a tape and batteries!) This music can be directed at the inhabitants of Funkytown to make them dance and thus not hinder you in your work. However (and there's always a "however") not all the townfolk respond to the musical notes you fire at them.

The worst bods to look out for are the Fun Angels who love to dance but possess a fatal touch and the Park Werewolves who you can cuddle at your peril.

There are nine other forms of nasty cruising the town, like Jack Flash, Gangsters of the Groove, Bandits of the Beat, The Tone Deaf Walkers and the

Karma Chameleons, all of whom have their own special properties (no I will not reveal all — you can work at it!).

The tapes are behind the red, gold and green flashing doors spread around the town, but to deliver the tapes you must also get a set number of people "Dancing In The Street" (sorry, I'm revealing my

age!). The number of people who have to dance is five times the number of tapes you have already delivered and the screen border will flash as soon as they are all dancing.

As you try to enter various shops around the town (electrical repairs, pub etc), various messages appear to advise you of your status, so you cannot



H-O-T G-O-S-S-I-P

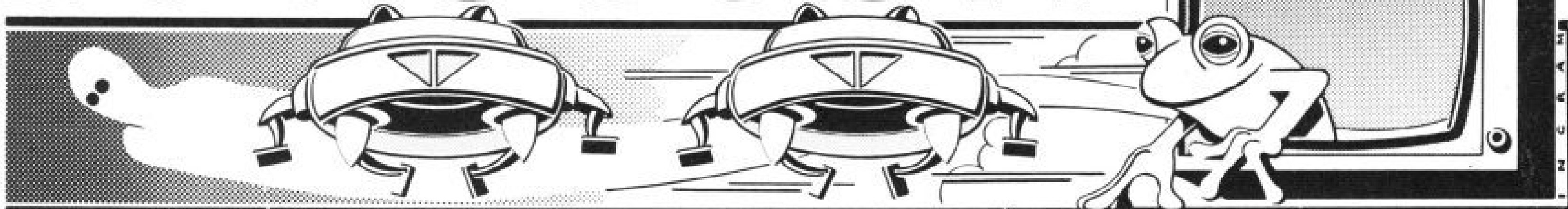

playability although it must be said that by current standards this is a good game for the C16.

A spaceman is trapped in a cave and has to defend alien flowers as they grow. When they reach full height, he can teleport to the next phase. Each phase has more aliens but with the same basic aim of zapping aliens and staying alive. There are power gauges to watch and mindless zapping will leave you defenceless until the batteries recharge.

This is a good game bearing in mind the current lack of top quality software for the C16 which hopefully will end as other companies enter the scene.

dawdle in the pub or hide in the park too long without being given the Order of the Boot.

The music in this game is enjoyable as it fits the scene well and does not irritate. In fact, there is an option to use the Commodore Music Maker Package by placing the music keyboard over the 64 and pressing the shift lock key down you can play along with the soundtrack.

There is also the option to turn the volume level of the ghettoblaster up or down for those late night sessions.

The graphics are slick, the town large and the challenge ever present so you should not find this an easy nut to crack. It's a very strong effort from a new solo programmer (ex-Taskset, see profile) and I suggest you keep an eye out for his future games.

GOSSIP

informed he has joined Ocean (although David Ward, the MD, has denied it) and may be involved in the relaunch of the Imagine logo under the auspices of the Ocean management. It's a strange old world...

●After my telephone call to Bug Byte last month, I now hear they have signed a deal with Quicksilva involving seven new games. This deal gives Quicksilva the rights to the seven new titles and is said to allow Bug Byte to concentrate on producing games. On the other hand, it could be that Bug Byte has cash flow problems and was bailed out by its old friend Rod Cousens at Quicksilva.....

●Does Jeff Minter TRULY feel for this fellow sheep? I can exclusively reveal that he does; and HOW do I know? Well at a recent trade dinner, Jeff was famished as he had not eaten all day BUT, on picking up the menu for that evening, he saw the following — SADDLE OF LAMB — and, despite his hunger pangs, he refused to eat the lamb. P S Guess who ate his portion..?

●Two golden oldies are, or shortly will be, no longer with us. Visions, those people with the large number of colour ads, and Oric have been put under compulsory liquidation.

Dare I say that you should hold on to the games and micros as they may be collector's items in years to come?

●I'm quite an Atari fan BUT a recent call to their Slough offices proved painfully funny.

I had a query over their new DOS3 disk drives and rang to get some clarification on the hardware.

"..Hello, can I speak to someone in technical please?"

Five minutes later and it was still ringing!

"I'm sorry he's in a meeting."

"You only have ONE man to answer all technical queries in Atari's UK headquarters?"

"(sigh) No two, it's silly isn't it? Have you tried Silica Shop..?" (fits of laughter at both ends of the line....).

●US Gold. An awfully large amount of money has been spent in promoting the US Gold logo and I hear that Vanguard leisure was due to enter the software scene with a similar GB Gold log. Well US Gold was not going to have any of it and took out an injunction to stop Vanguard sending out any games under the logo.

I'll keep you posted on developments as they arise.

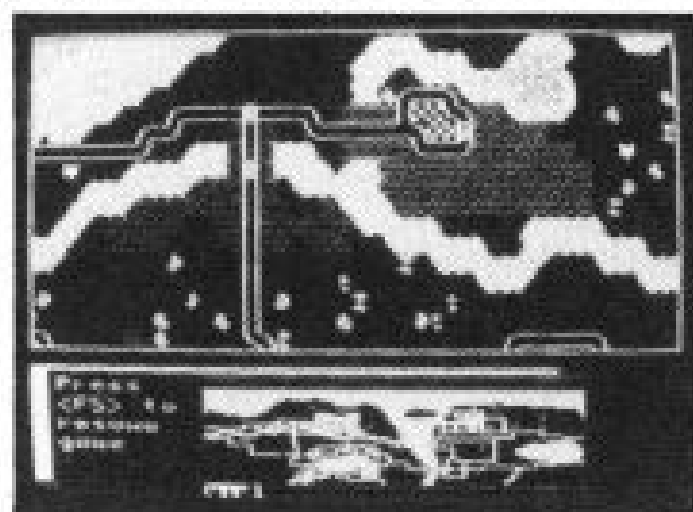

D-DAY FOR THE QL!

Games Workshop have upgraded their D-Day wargame for the QL.

The workshop people are claiming that this is the first original graphic game for the machine.

Mike Singleton reviewed the Spectrum version last issue — so check your back issues for more details on the game!

D-Day for the QL will sell at £24.95. The game has also been converted for the 64, priced at £8.95.

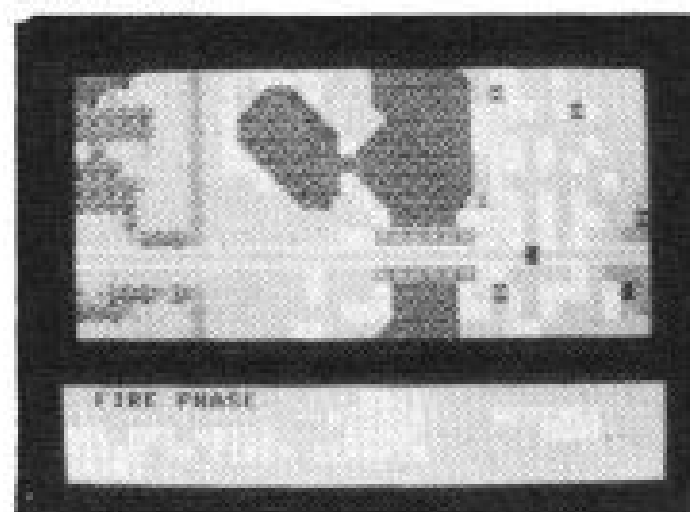

CHANNEL 4

If you were watching Channel 4's new computer programme *Computer Buffs* on March 4th, you will have seen C&VG's ace Adventurer, Keith Campbell, talking all about our Adventure Helpline! Yes, he is very tall isn't he!

The Channel 4 series, which goes out at 5.30 pm on Mondays, aims to bring you up-to-the-minute news and gossip from the wonderful world of computers. And like the BBC's *Chip Shop* programme, Channel 4 will also be broadcasting free software.

The program is also pioneering the transmission of software by light — and will be showing how to construct the circuitry for a light pen which can be used to capture the "lightsoft" programs.



EUROPE'S LEADING
'ATARI'
MAIL ORDER
SPECIALISTS



HOTLINE (021) 384 5080

800XL + 1050 DISK DRIVE

INCLUDES DISK OPERATING SYSTEM
SOUND & GRAPHICS DEMO
HOME FILING MANAGER
THE 'PAYOFF' ADVENTURE

FREE
NORMAL PRICE £364.96
OUR PRICE £249.99
SAVE £115.00

WHILE STOCKS LAST

THE ATARI XL HANDBOOK	£5.95
DE RE ATARI	£17.00
MAPPING THE ATARI	£12.60
YOUR ATARI COMPUTER (incl. XL)	£17.50
TECHNICAL REFERENCE NOTES	£17.00
THE XL GRAPHICS HANDBOOK	£7.95

FROM O.S.S.
MAC/65 (ROM) & TOOLKIT (DISK)
BASIC XL (ROM) & TOOLKIT (DISK)
ACTION (ROM) & TOOLKIT (DISK)

COMING SOON!
ATARI 520 ST
PHONE FOR DETAILS



800XL + 1010 PROGRAM RECORDER

INCLUDES SOUND & GRAPHICS DEMO
INVITATION TO PROGRAMING
+ POLE POSITION

FREE
NORMAL PRICE £194.96
OUR PRICE £129.99
SAVE £65.00

INFOCOMS INVISICLUES £7.10 PER TITLE

NOW OPEN
ATARI
SERVICE DEPARTMENT

NEW 'U.S. GOLD' TITLES
DROP ZONE C/D £9.95/12.95
MR DO C/D £9.95/14.95
COMBAT LEADER C/D £14.95
DIG DUG C/D £9.95/14.95
PAC-MAN C/D £9.95/14.95
F15-STRIKE EAGLE C/D £14.95

MAGAZINES
ANTIC PAGE 6
ANALOG ATARI USER (NEW)

MINER 2049ER £12.95 ROM

THE SEQUEL TO MINER 2049ER
BOUNTY BOB STRIKES BACK
ROM

PHONE FOR AVAILABILITY

GHOSTBUSTERS £14.95 DISC

SEND SAE FOR PRICE LIST
31 STONEYHURST ROAD,
ERDINGTON,
BIRMINGHAM.
Telephone: (021) 384 5080

ADD £5.00 P + P TO 800XL PACKS AND 75p TO BOOKS P + P REG ATARI CORPORATION (U.K.) LTD

YOU CAN'T MISS THIS UP TO 75% DISCOUNT

ON OUR VAST RANGE OF
SOFTWARE & ACCESSORIES

Just a few examples:

	MRP	F.D.D.
VALHALLA - Spectrum	£14.95	£3.75
GREAT SPACE RACE - Spectrum	£14.95	£3.75
BRISTLES - Com 64	£ 8.95	£2.25

Plus ALL other current & new releases at amazingly low prices.

When you become a member of Flix Direct Discount Club you will receive:-

- Your own Personal Membership Certificate.
- Our very latest software catalogue containing 100s of top titles for the Spectrum, C64, C16 & +4, VIC 20, BBC Electron, Atari & Amstrad.
- Details of incredible offers on a wide range of joysticks, Interfaces & other accessories.
- Regular new release information pack.
- Your free £1 voucher to use against any future FDD purchase.

To become a member and receive all the above benefits simply send cheque or P.O. for £1.50 made payable to 'Flix' together with your name, address and computer type to:-

Flix Direct Discount Club
FREEPOST Congleton, Cheshire CW12 1BR
(NO STAMP REQUIRED)

If you wish to take immediate advantage of any of the above offers please add cost of purchase to your Registration Fee. All registrations and orders will receive our immediate attention.

MILES BETTER SOFTWARE

221 Cannock Road, Chads Moor,
Cannock, Staffs WA11 2DD.

Tel: 05435 3577

U.S. GOLD SOFTWARE

Title & Machine	Cass	Disk		
Nato Commander (64)	£8.95	£12.95		
Beach-head (A)	N/A	£12.95	Indiana Jones (64)	£8.95 N/A
Beach-head (64)	£8.95	£11.95	Tapper (64)	£8.95 £11.95
Beach-head (Amstrad)	£8.95	N/A	Tapper (ZX)	£8.95 N/A
Beach-head (ZX)	£8.95	N/A	Congo Bongo (64)	£8.95 £11.95
Conan (A)	£8.95	£12.95	Congo Bongo (ZX)	£8.95 N/A
Conan (64)	£8.95	£12.95	Spy Hunter (64)	£8.95 £11.95
Pole Position (A)	£8.95	£12.95	Spy Hunter (ZX)	£8.95 N/A
Pole Position (64)	£8.95	£12.95	Up and Down (64)	£8.95 £11.95
Mr Do (A)	£8.95	£12.95	Up and Down (ZX)	£8.95 N/A
Mr Do (64)	£8.95	£12.95	Buck Rogers (64)	£8.95 £11.95
Pacman (A)	£8.95	£12.95	Buck Rogers (ZX)	£8.95 N/A
Pacman (64)	£8.95	£12.95	Wizard and the Princess (64)	N/A £11.95
Digdug (A)	£8.95	£12.95		
Digdug (64)	£8.95	£12.95	Mission Astroid (64)	N/A £11.95
Dropzone (64)	£8.95	£11.95	Exodus: Ultima III (64)	N/A £17.95
Raid over Moscow (64)	£8.95	£11.95	Dough Boy (64)	£8.95 £12.95
Raid over Moscow (ZX)	£8.95	N/A	Quasimodo (64)	£8.95 £12.95
Strip Poker (64)	£8.95	£11.95	Sentinal (64)	£8.95 £12.95
Aztec Challenge (A)	£7.95	N/A	Ulysses and the Golden	
Forbidden Forest (A)	£7.95	N/A	Fleece (64)	N/A £11.95
Slinky (A)	£7.95	N/A	Combat Leader (64)	£12.95 £12.95
Caverns of Khafka (A)	£7.95	N/A	Battle for Normandy (64)	
Super Huey (64)	£8.95	£11.95		
Talladega (64)	£8.95	£11.95	Grogs Revenge (64)	£8.95 £11.95
Bruce Lee (64)	£9.95	£12.95	Fort Apocalypse (64)	£8.95 £12.95
Bruce Lee (A)	£12.95	£12.95	Fort Apocalypse (A)	£8.95 £12.95
Dallas Quest (A)	N/A	£12.95	Drelbs (A)	£8.95 £12.95
Dallas Quest (64)	N/A	£12.95	Drelbs (64)	£8.95 £12.95
Stellar 7 (64)	£8.95	£11.95	Blue Max (A)	£8.95 £12.95
Solo Flight (A)	£12.95	£12.95	Blue Max (64)	£8.95 £12.95
Solo Flight (64)	£12.95	£12.95	Blue Max (ZX)	£8.95 N/A
F15 Strike Eagle (A)	£12.95	£12.95	Zaxxon (A)	£12.95 N/A
F15 Strike Eagle (64)	£12.95	£12.95	Zaxxon (64)	£8.95 £12.95
Nato Commander (A)	£8.95	£12.95	Zaxxon (ZX)	£8.95 N/A

Please phone for stocks availability on all items. Add £1 per item for overseas orders. Access and Visa welcome.

PLEASE PHONE FOR ATARI SOFTWARE LISTS



Graphics: Are they really as mind-blowing as the adverts say they are? Does the screen scroll effectively? Do those aliens really leap out of the screen at you? This is how this category is judged

1 GYRON

MACHINE: Spectrum
SUPPLIER: Firebird
PRICE: £9.95

Now here's a really DIFFERENT game! You may not think that a 3D maze game could be different — but *Gyron*, the latest full price game from Firebird, most definitely is.

The idea of the game is to penetrate the defences of a vast maze-like structure created by a sorcerer scientist to protect his knowledge. The maze is confusing enough on its own — but the sorcerer also decided to make it deadly by constructing laser towers to zap any intruders.

Faced with this formidable task, the sorcerer's enemies gathered to discuss just how they could break into the system. The result was a Hedroid — a remote controlled probe robot armed with a high-intensity optical laser.

And this is where you come in! Take control of the Hedroid, guide it through the deadly maze and discover the sorcerer's secrets — which is not as easy as it sounds.

The Hedroid can be damaged by collisions with the walls — and can be totally wiped out by the giant *Prisoner*-type "rovers" which trundle through the maze.

The laser towers are multi-directional — and totally featureless when viewed from the outside. Fortunately, your Hedroid is armed with radar and it can check out which way the tower is likely to be pointing its deadly weapon. You can either destroy the tower or make it turn by zapping it with the Hedroid's laser.

The screen display shows a main view of the maze — plus an image of the Hedroid itself which changes colour as you progress through the various zones of the maze, a "viability" or energy indicator



Porsche 924 or cash equivalent as a prize for the first person who cracks the Necropolis maze version of the game first.

You notice I said Necropolis version. On the B-side of the tape there will be an easier version of the game called the Atrium. This is great for practising — or for those of you who like a faster game. But no prizes for solving it!

Oh yes — there is a time limit built into the hard version. Expert opinion says that if you've spent around 20 minutes trying you might as well start another game!

Graphics — as you can see from our shots — are vector line style. But don't let the simplicity fool you. The

plus a radar screen illustrating your surroundings.

Colour bars of red and green which appear at the sides of the main display are used to indicate side passages — your Hedroid can only see in the direction it is facing.

You can control the Hedroid using a joystick or keyboard — user definable keys are a feature of the game too!

Gyron is an immensely challenging game and — just to make it more interesting — Firebird are offering a

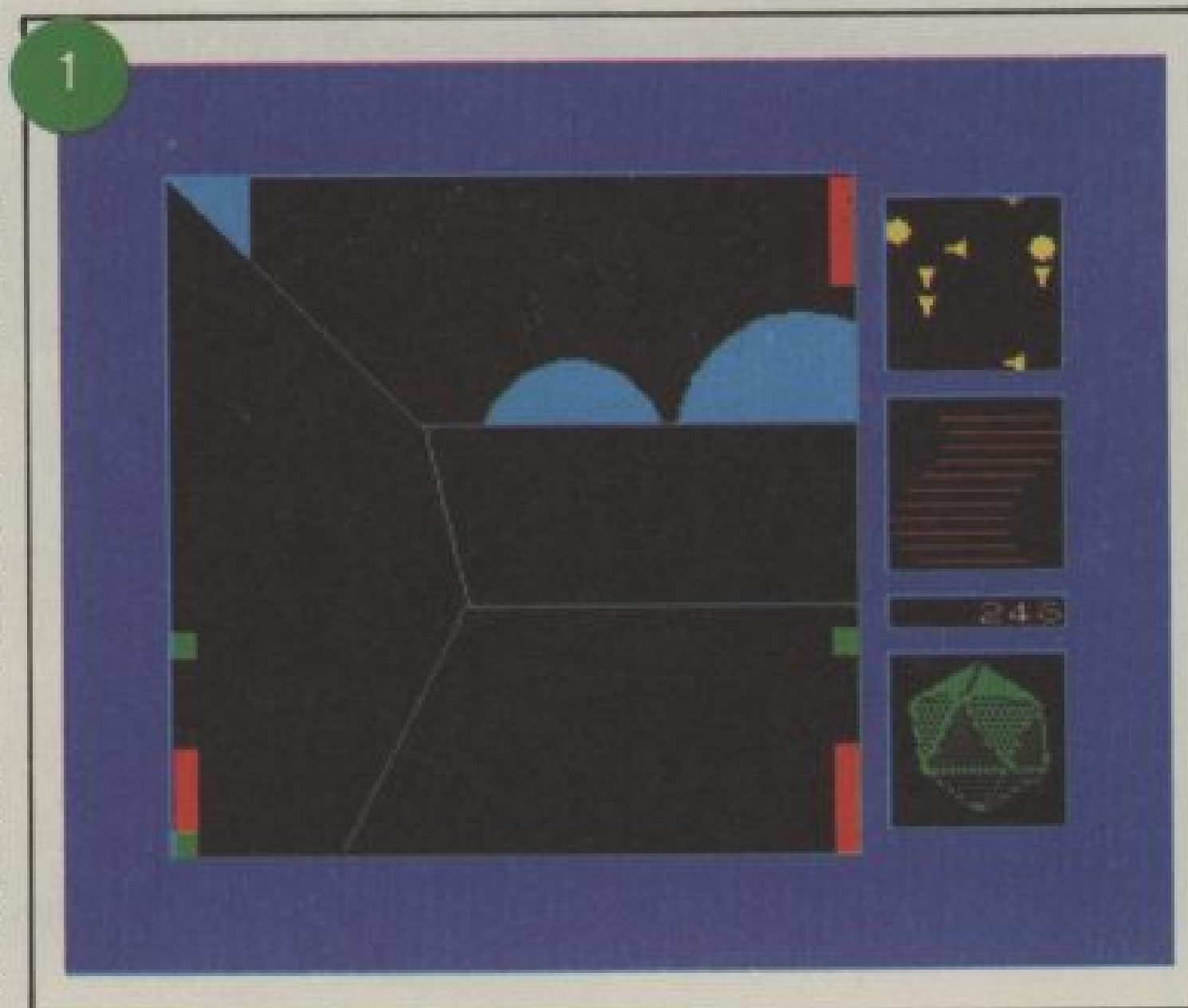

programmers, two mathematicians and two computer boffins, have developed a neat way of moving things behind other things on screen — if you follow me! Just watch the giant robot rovers and you'll see what I mean.

Once you've got the hang of driving the Hedroid around the maze — and it does take a bit of getting used to — you'll be hooked. Don't fail to have a look at Firebird's best full price game yet.

● Graphics	9
● Sound	8
● Value	9
● Playability	10



R·E·V·I·E·W·S

Sound: Does the game sound like a Duran Duran LP played at half speed — or does the noise from your micro knock you half-way across the room? The C&VG review team don't judge games with their ears plugged up, we can tell you!



2 SHOOT THE RAPIDS

MACHINE: CBM 64
SUPPLIER: New Generation
PRICE: £7.95

An interesting sports simulation from New Gen. The graphics are pretty basic but game play is enthralling. You just have to get your paddling action right to get your canoe right way round across the finishing line. I spent a lot of time going backwards down the river!

The object of the game is to complete a series of slalom courses against the clock — avoiding hazards like rocks and motor boats along the way. Each river flows at a different speed — so you have to be on the ball to beat the clock.

A Decathlon-style joystick action won't help you to succeed in *Shoot the Rapids* — you must be cool calm and collected.

A novel and interesting game for water sports fans.

● Graphics	7
● Sound	7
● Value	7
● Playability	8

3 SEASIDE SPECIAL

MACHINE: CBM 64
SUPPLIER: Taskset
PRICE: £6.90 cass./
£9.99 disc

Here's the antidote to *Raid Over Moscow* for peace people and conservationists everywhere.

The general idea of the game is to collect radio-active seaweed from a polluted

beach — avoiding mutant guards and jellyfish — and to take it to Downing Street where you must chuck it through the windows at well known members of the Cabinet who pop up at the windows.

Just to distance the game a bit from real life, the scenario for the game says that the pollution has been caused by a nasty bunch of aliens called Polytikians who have invaded earth and taken over the government, taking on the appearance of the real Cabinet ministers.

The hero of the game is Radium Rodney, who has stumbled on the awful truth and realises that the only way to stop the insane Polytikians is to bombard them with the atomic seaweed!

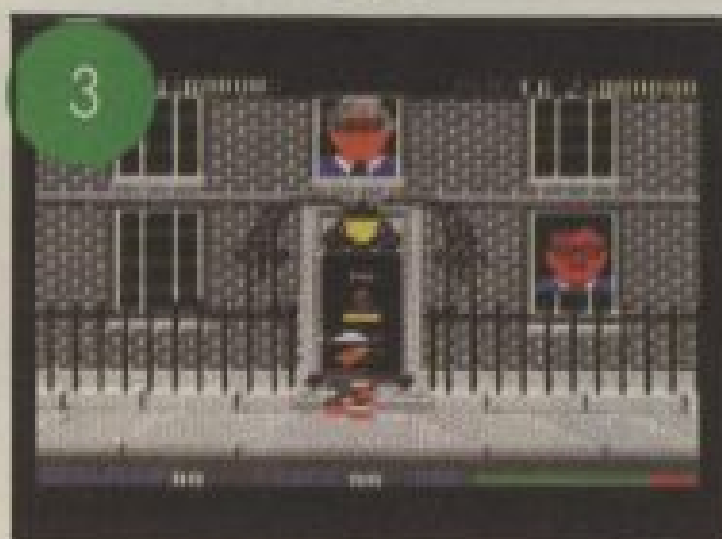

The evil Polytikians are easily recognisable in the "Downing Street" screen. Pick your least favourite Tory minister and chuck something at him. Very satisfying — unless of course you are a Young Conservative!

Seaside Special is a novelty game — and its lasting appeal could be limited. But if you fancy a laugh have a look at it.

● Graphics	8
● Sound	8
● Value	7
● Playability	8

4 AQUA RACER

MACHINE: CBM 64
SUPPLIER: Bubble Bus
PRICE: £6.99

Ever wondered what *Pole Position* with boats instead of cars would be like? Then check out *Aqua Racer* from Bubble Bus.

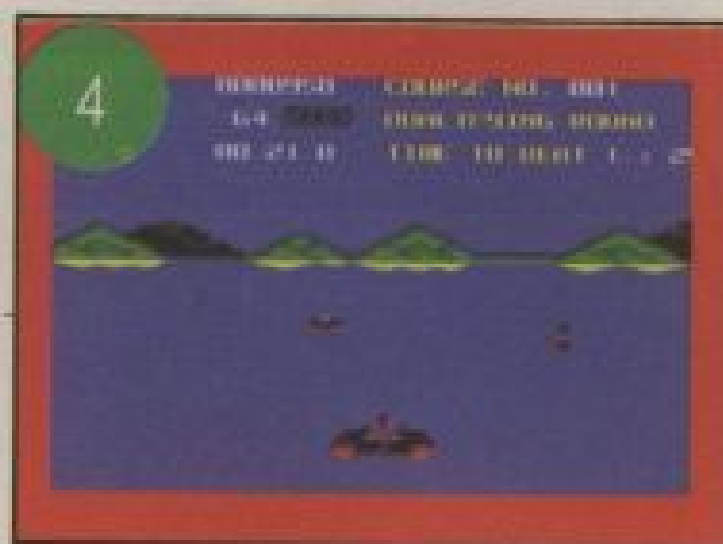

It's got nice 3D style graphics and good sound — and it's fun to play, too.

The idea is to race your powerboat against the clock over a series of different courses. Lots of other boats attempt to stop you claiming the powerboat championship.

There are 20 courses to race on — plus a qualifying round in true *Pole Position* style.

Aqua Racer is a nice twist on the *Pole Position* theme. A game for race fans.

● Graphics	8
● Sound	7
● Value	7
● Playability	8

5 SLAPSHOT

MACHINE: CBM 64
SUPPLIER: Anirog
PRICE: £8.95 cass./
£10.95 disc

There's only one thing wrong with this superb sports simulation from Anirog. You have to have two people to play it.

WHY didn't you include a player vs computer option, Anirog!

OK. Gripping over with. Now onto the good news. *Slapshot* is an accurate representation of that rough tough sport, ice hockey.

The aim of the game is simple — to score goals. Achieving that aim involves a mixture of ice skating skill, strategy and brute strength — I've heard that the real life game is a bit like that too!

The simulation follows the rules of the game closely. Each game consists of three three-minute periods — and yes, you do earn a penalty if you deliberately chop an opposing player down!

The graphics are simple but effective — and the game also features speech. You hear the roar of the crowd when you score a goal and an announcer at the start of each period. The crowd sounds are terrific!

I particularly enjoyed the considerable joystick skills you MUST develop to get your skaters performing effectively. A real challenge this.

Overall, *Slapshot* must rate as one of Anirog's best games to date. Great fun and great value.

● Graphics	9
● Sound	9
● Value	9
● Playability	9

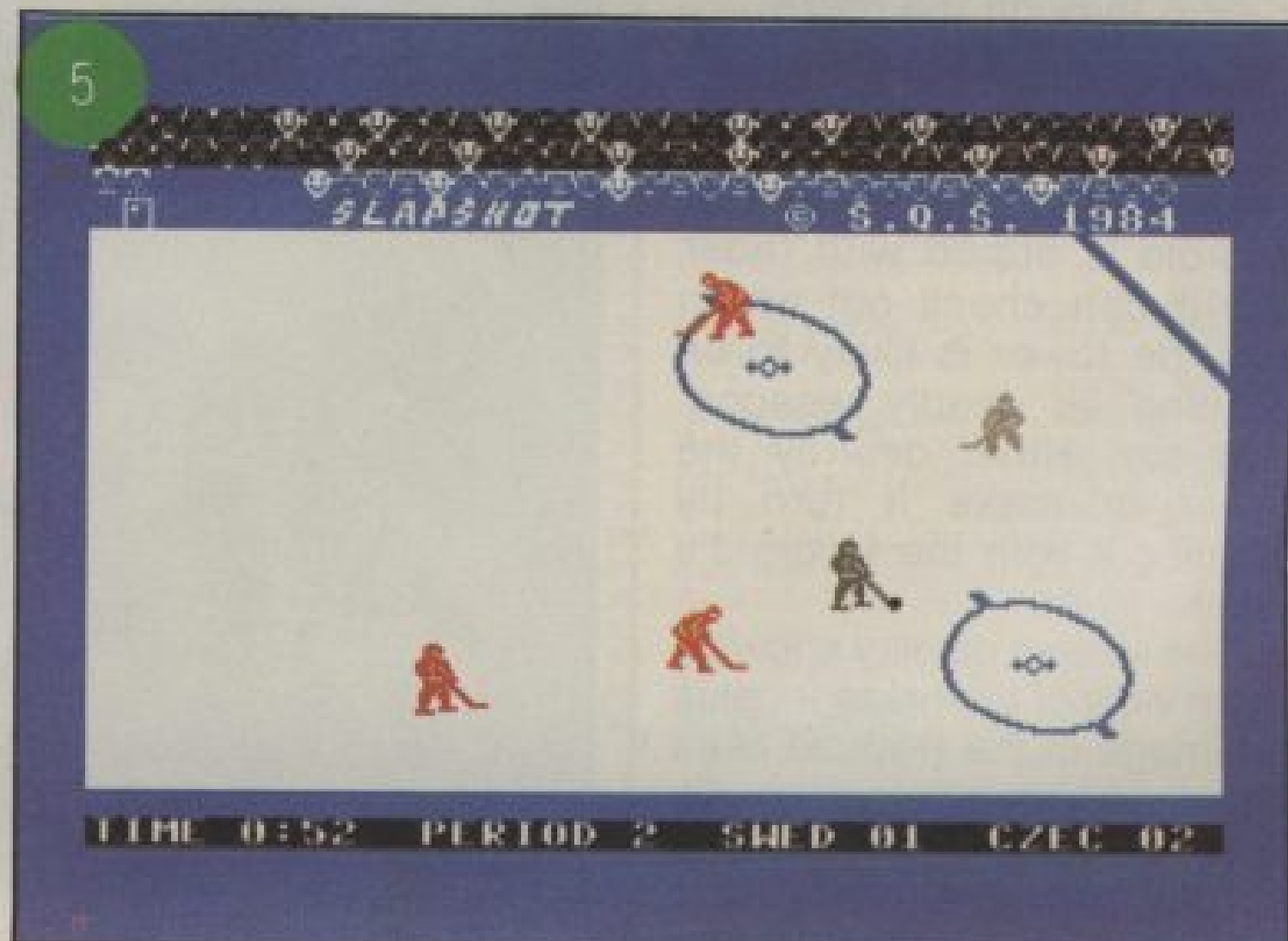

911 TS

CBM 64
£9.95
SPECTRUM £7.95
AVAILABLE NOW!



Produced with technical assistance from:



A mean evening. The world's leading sports car. A blocked road, and an uncharted maze of hillside lanes. The ingredients of the thrilling new rally simulation '911 TS'.

Drive it NOW!

Every single 'ELITE' product carries the unique 'ELITE Holographic Sticker'. Make sure your copy does, it's your guarantee of quality.

Mail Order: Just send a cheque or P.O. payable to 'ELITE' or quote your visa number.

elite



R·E·V·I·E·W·S



Value: Is the game really worth all those pennies? How long will its attraction last? Is it worth going without Computer & Video Games for a month because your parents won't give you any extra pocket money — or could you write a better listing?

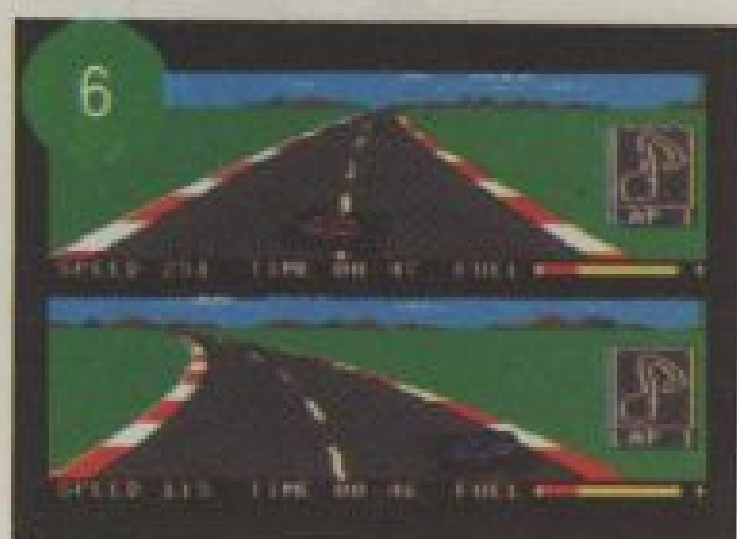

You can race on all the major Grand Prix circuits of the world — except, strangely, Silverstone — the home of British motor sport.

You can also compete in the Grand Circuit, racing on each track over a "season".

There is a championship table which flashes up after each race, and several skill levels — from rookie to pro. Now, where did I put my crash helmet...

swimming around to the *Jaws* theme in a third.

This is the best *Blogger* game yet. Don't fail to catch the opening night!

arcade adventure style. He'll need them all before completing this challenge.

The graphics are terrific — similar in style to *Atic Atic* and *Sabre Wulf*. Animation is smooth and flicker free and the sound is good too. Some screens have *Sabre Wulf*-style jungle while others have rocks or *Atic Atac* rooms.

● Graphics	9
● Sound	10
● Value	9
● Playability	10

6 PITSTOP II

MACHINE: CBM 64
SUPPLIER: CBS/Epyx
PRICE: £9.95



Slip into the driving seat and prepare for the best Formula One racing game since *Pole Position!*

Pitstop II not only features the usual race sequence but also an exciting pitstop screen where you have to refuel and change the tyres on your high-performance race car before the other racers get too far in front!

As you race against the opposition, you have to keep an eye on the condition of your tyres and fuel. The harder you drive, the more your tyres wear and you could end up stuck out on the circuit with a blown tyre if you don't take care.

Race against the computer or a friend in this terrific race simulation. *Pitstop II* features a split screen, *Spy Vs Spy* style. Each part of the screen shows the scrolling track and the other race cars — until you decide to make a pitstop that is. Then the display switches to the pits where your crew wait to refuel and change the tyres on your racer. This can get pretty frantic as the computer controlled car — or your friend's racer — gets further in front!

You can check on your tyre wear by watching for a colour change — when they turn white you are in big trouble.

The graphics are excellent and the sound is great — lots of roaring engine sounds — best of all, though, *Pitstop II* is great fun to play.

● Graphics	9
● Sound	9
● Value	9
● Playability	10

7 HOLLYWOOD

MACHINE: CBM64
SUPPLIER: Alligata
PRICE: £9.95

Alligata's software star, *Blogger*, heads for Tinsel Town and the biggest job of his career so far in *Blogger Goes to Hollywood* — an all-action, arcade Adventure.

Set among the many studios of a giant Hollywood film company's headquarters, the game sets *Blogger* a tough task. He has to reach the office of ace producer Spielbum — best known for his epic action movies *Teeth* and *Close Encounters of the Nasty Kind* — and steal the only copy of his latest film!



Theme tunes for various movies associated with the characters you find in each studio play as you enter different screen. For example, you get the *Star Wars* theme and a little Darth Vader in one studio, the *Superman* theme and the Man of Steel himself in another, and a giant shark

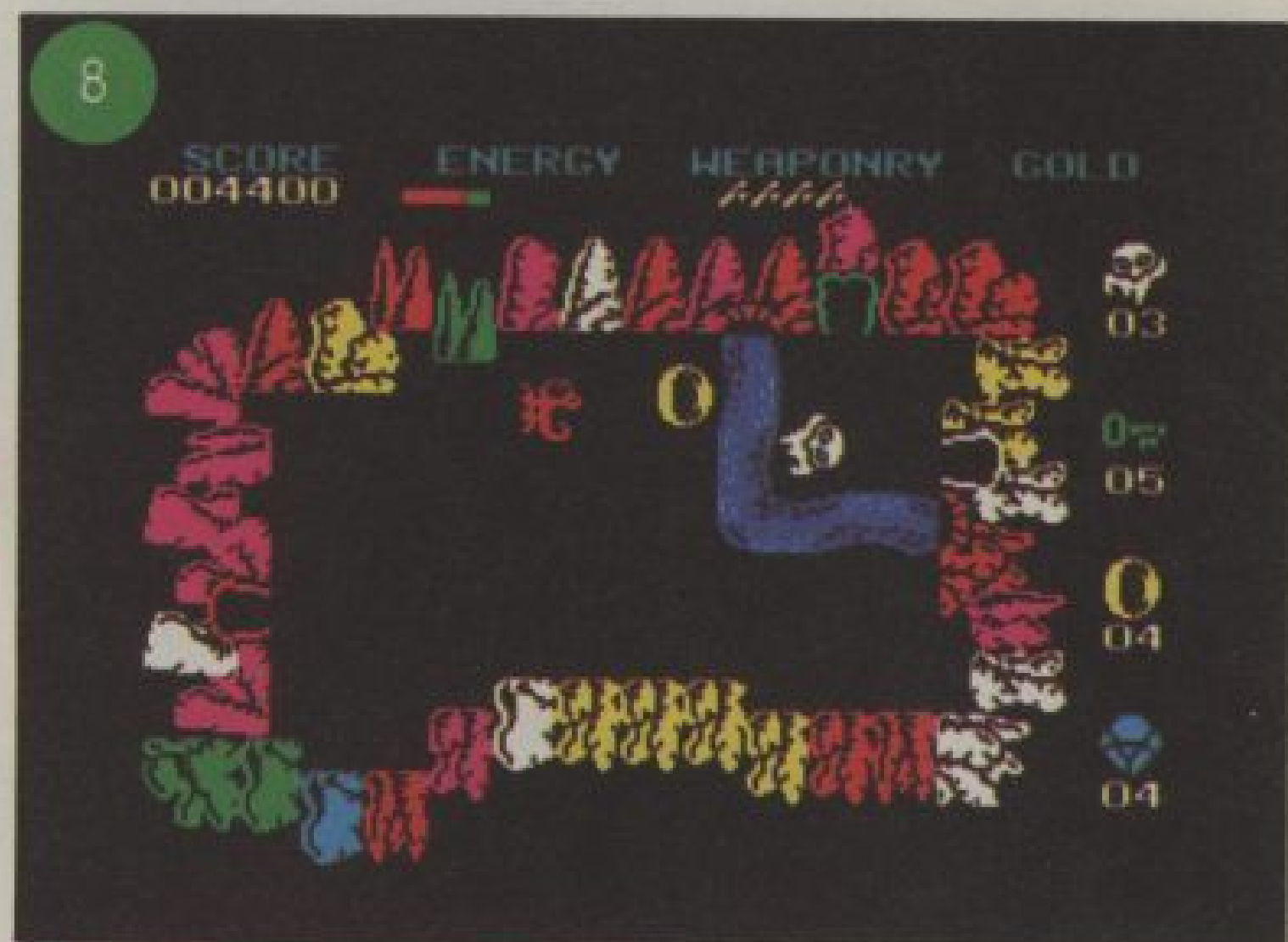

8 WIZARD'S LAIR

MACHINE: Spectrum
SUPPLIER: Bubble Bus
PRICE: £6.99

This must be the best game yet from Bubble Bus! Programmer Stephen Crow readily admits that he was inspired by Ultimate's *Atic Atac* when writing the game — but what's wrong with taking an idea and developing it? Just look at all the JSW clones around.

Anyway, on to the game which revolves around the adventures of a character called Pothole Pete who has accidentally discovered the Wizard's Lair while on a pot-holing expedition.

Pete has heard rumours about this place and knows that scattered around are bits of a magical golden lion — and sets out to discover them. But the Lair is inhabited by some really horrible monsters who guard the golden lion.

Pete can collect weapons, food, spells, keys and gold during his quest — in true

Each of the nasties has its own particular characteristics which you must learn before engaging them in battle, which adds to the challenge of the game.

A worthy sequel to *Atic Atac*. *Wizard's Lair* is extremely well presented, great fun to play and terrific value for money.

● Graphics	10
● Sound	9
● Value	10
● Playability	10

WITCH SWITCH

MACHINE: CBM 64
SUPPLIER: English Software
PRICE: £8.95

Suddenly everyone is making games about witches — and it's nowhere near Halloween! Still, English Software's *Witch Switch* was one of the first — and an entertaining romp it is too!

You take on various forms during the game — a monkey,

continued on page 100

The BOND DIARY

COMING SOON TO A C&VG NEAR YOU!

"My name is Bond. James Bond. . ." How many times have you thrilled to these words! They mean that action and adventure are just a few short film frames away. Now Bond is back in town and soon to be seen saving the world again in a brand new 007 epic called *A View to a Kill*. And, at last, there's a Bond computer game to go along with it! Yes, 007 comes to the small screen thanks to the people who brought you *Eureka!* Over the next couple of issues *C&VG* will be tracing the development of the Bond game — bringing you all the inside information on how it came to be — in **THE BOND DIARY**. It promises to be just as intriguing as one of the Bond plots. This issue we'll be telling you a bit about the background to the game. Next issue we'll bring you exclusive screen shots of the game itself — and then in July *C&VG* will proudly present an 007 extravaganza with competitions and much more. Bet you can't wait! In the meantime, on with the main feature . . .

It all started when Mark Strachen and Dominic Wheatley, the people who master-minded the £25,000 prize adventure game Eureka! began looking around for a follow-up.

They learned about the new Bond movie A View to a Kill and immediately saw the great potential for a computerised version of 007's adventures. But this time they wanted an arcade game — not an adventure. After all Bond movies are packed with action!

They set about acquiring the licence to the movie for an as yet undisclosed fee and began looking around for a software company good enough to come up with the goods.

They chose Softstone, a relatively unknown company with the advantage of having a team of very talented programmers. Another company, called Special K, who specialise in game design and production, created the storyboards for the game which Softstone then began to turn into data and graphics.

The brief to Special K and Softstone was to produce four arcade-style games based on stunts featured in the movie.

Domark struck lucky when they discovered that a friend was a film editor actually working on the Bond movie. He was quickly snapped up to help make sure that the games look as close to the film as possible.

Meanwhile, that supergroup Duran Duran had been chosen to write the theme music to A View to a Kill — and Domark decided that they wanted to use the same

music on the game and set out on yet another quest for a licence. It proved successful and the Duran Duran sound will be featured for the first time on a computer game.

Another first for Domark is that the game will be released at the same time as the Bond movie hits the cinema screens. The Ghostbusters! game came along sometime after the movie.

And talking of Ghostbusters!, ace programmer and head of Activision, David Crane, has seen storyboards of the game and loves the look of it! Activision will be handling the game in the US.

The A View to a Kill game is being written for the Spectrum, Commodore 64, Amstrad and MSX — and an Enterprise version could be on the cards.

The royal premier of the movie will take place in London on June 12th.

What would Bond think about all this? Well, according to Mark and Dominic, the current James Bond in the elegant form of Roger Moore enjoys playing computer games. We hope to bring you his views of the 007 game!

Next issue we'll bring you some exclusive screen shots of A View to a Kill plus an inside view of the programmers at work.

Don't miss it!

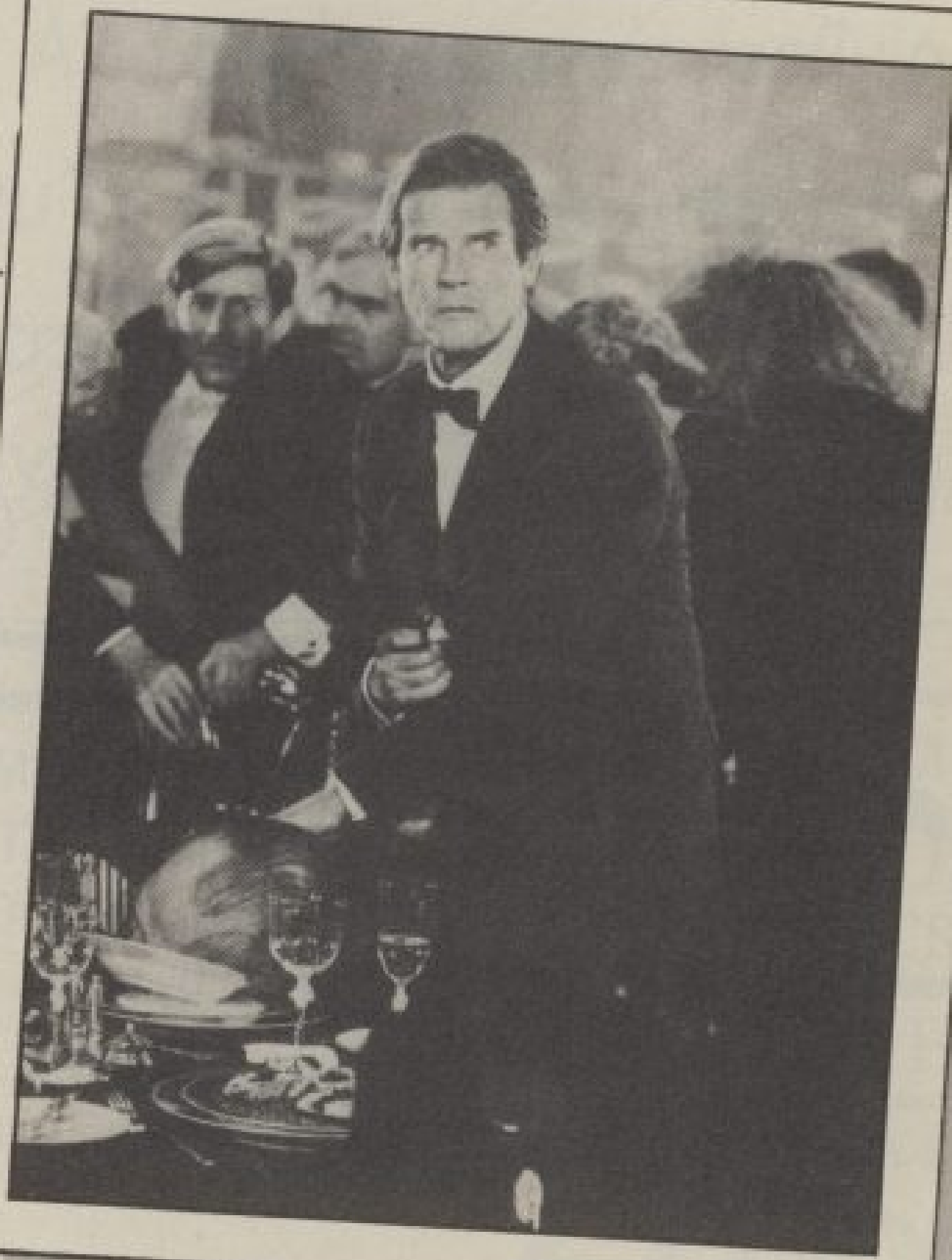
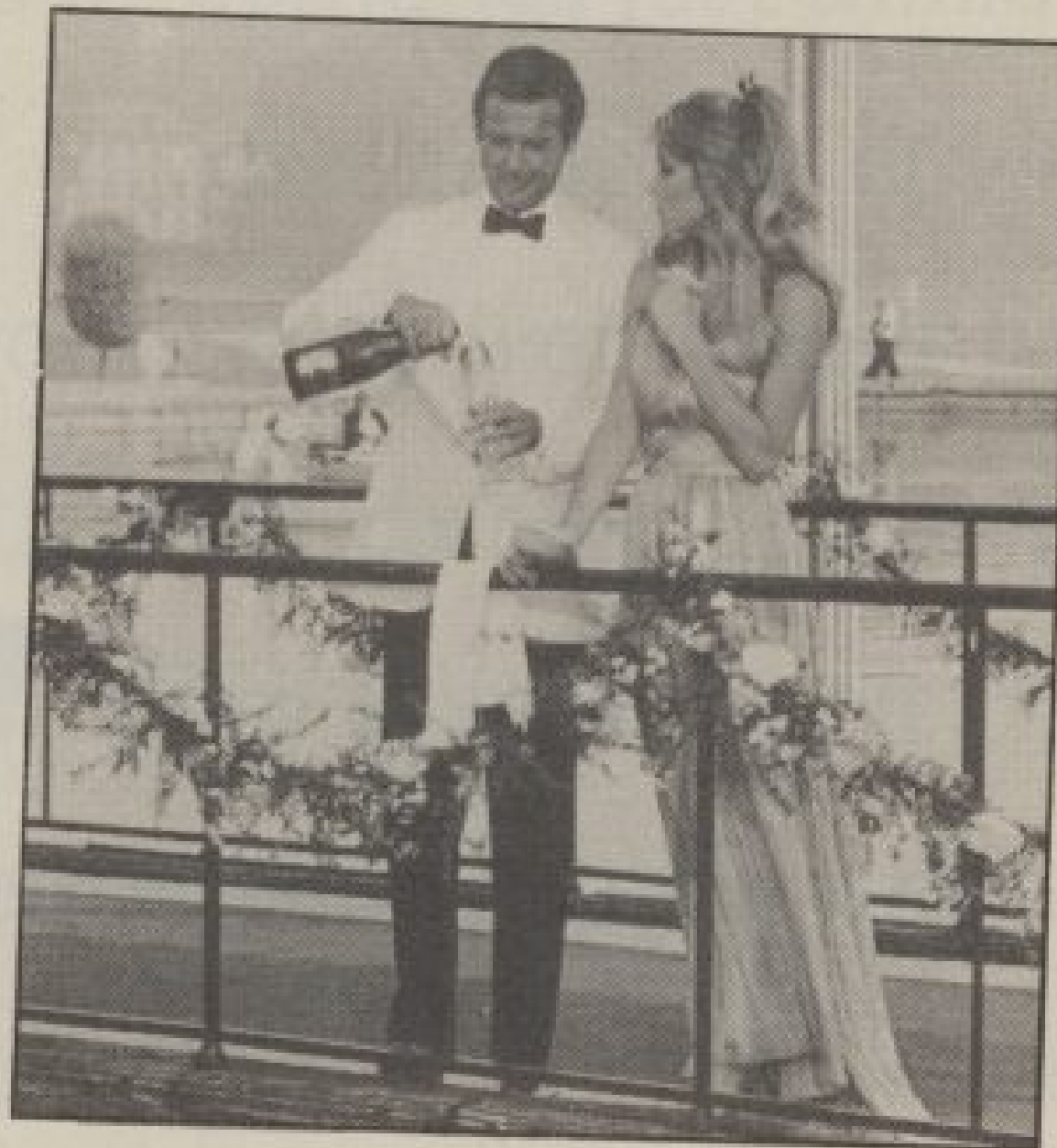
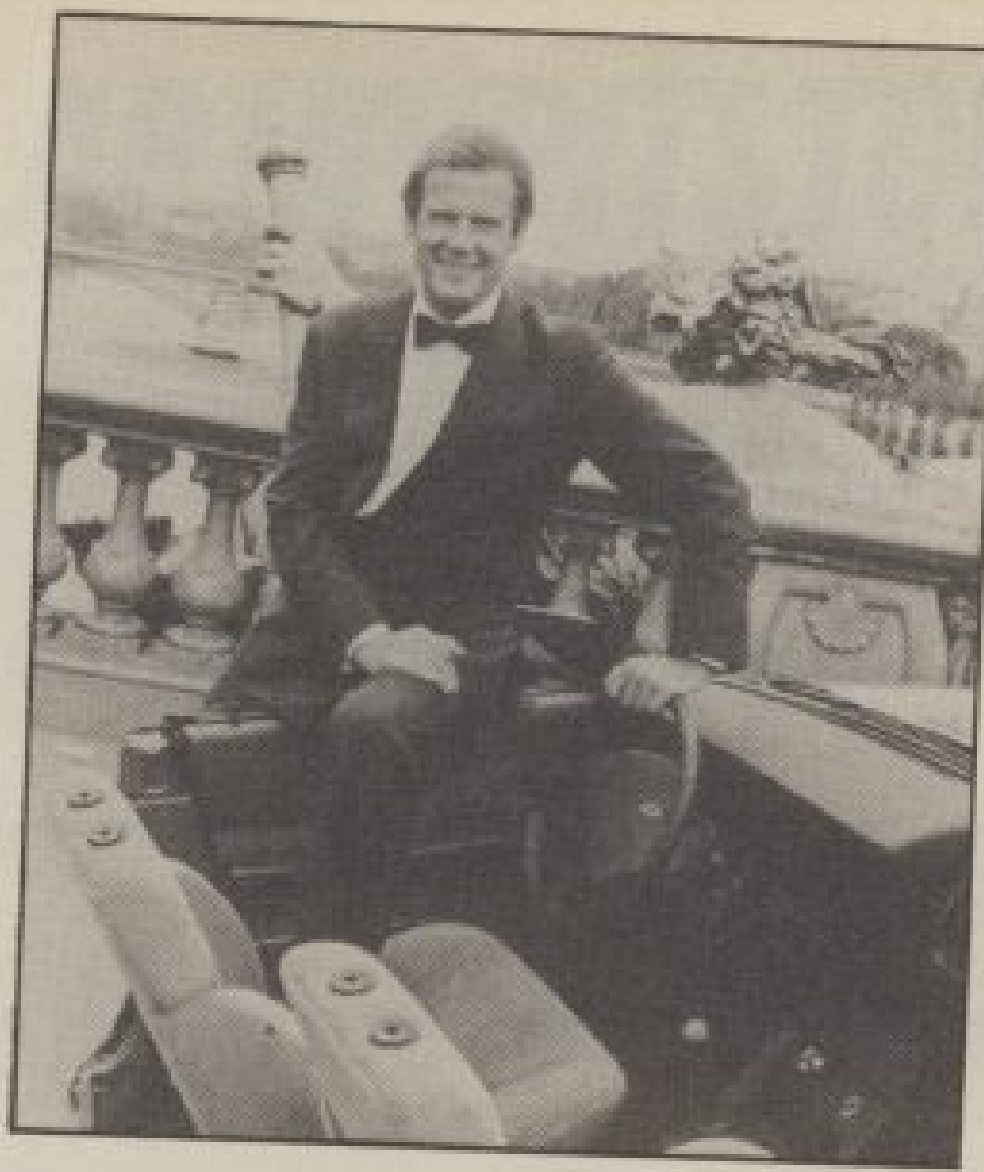

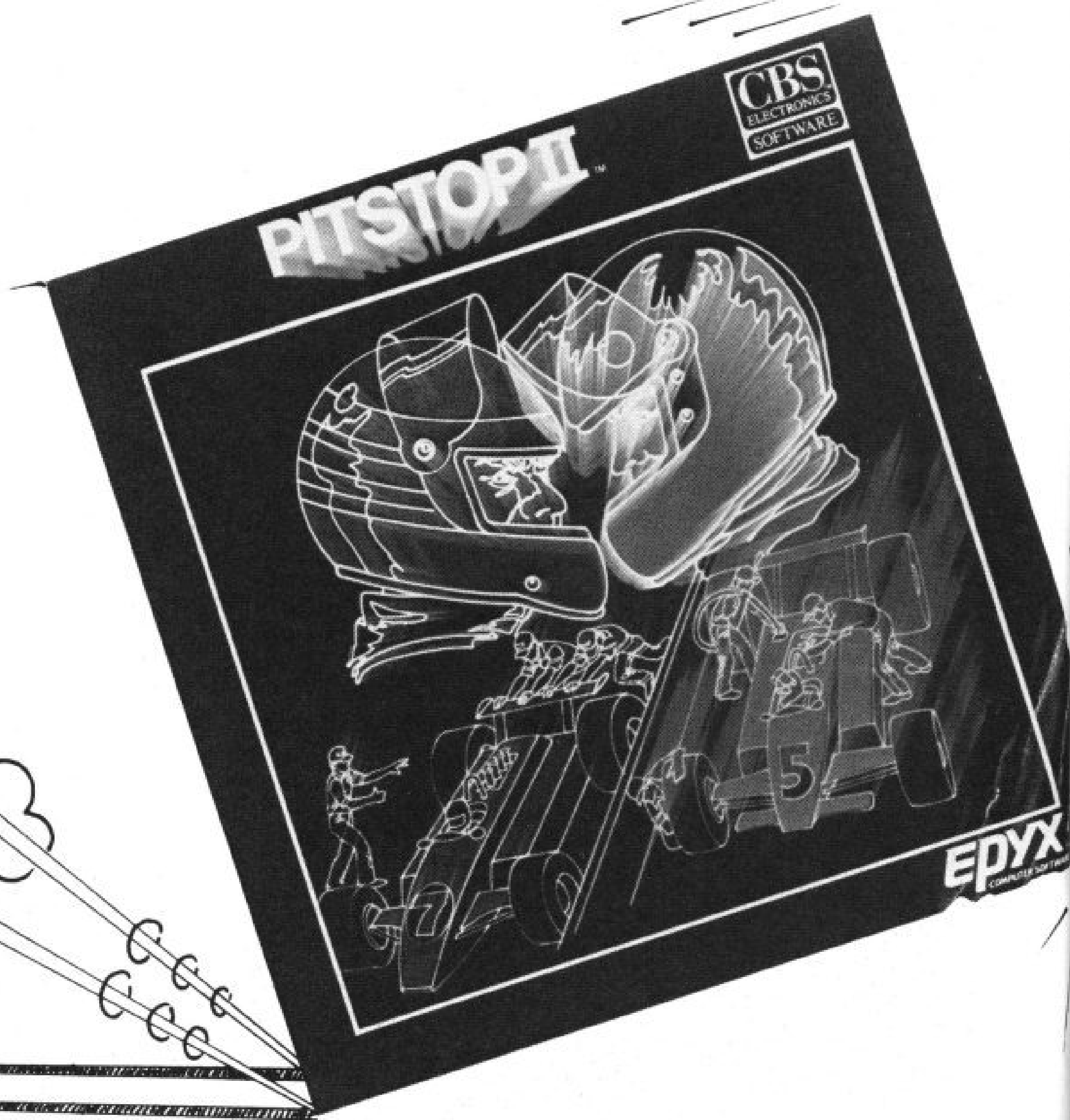
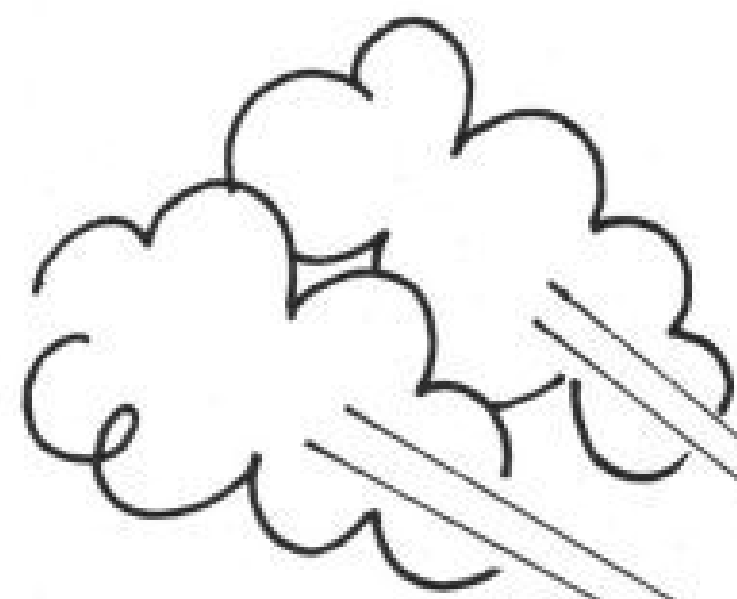

IF YOU DRIVE FAST AND THINK FAST, YOU'LL LAP UP 'PITSTOP II.'

'Pitstop II' is here.

*And with it comes all the thrills, spills
and nerve-jangling action of competitive motor racing.*

*But there's much more to 'Pitstop II'
than just foot down, flat out and hope for the best.*

*Because 'Pitstop II' demands fast thinking
as well as fast driving.*

*You've got to watch your tyres; watch your fuel;
watch that car coming up behind.*

You've got to decide whether you can afford to make a pit stop.

Or whether you can afford not to.

*With 'Pitstop II' you not only drive your race,
you plan it as well.*

And the pressure's really on.

If you think you've got action games licked,

try a few laps with 'Pitstop II'.

You may have to think again.

Also out now on Epyx:
IMPOSSIBLE MISSION • PITSTOP I
BREAKDANCE • TEMPLE OF APSHAI
SILICON WARRIOR • JUMPMAN
DRAGONRIDERS OF PERN • LUNAR OUTPOST
Plus new releases:
STARFIRE AND FIRE ONE • MURDER BY THE DOZEN

Available from all good software outlets. Authorised dealers order from:
The Software Sales Service. Tel: 01-636 6433/4. CBS Computer Software,
Ashbrook House, 3-5 Rathbone Place, London W1.



FOR COMMODORE 64



AMSTRAD THE TOMB OF KUSLAK

A graphic and text adventure
with the following features:

OVER 240 LOCATIONS • 5 SKILL LEVELS •
DIFFERENT EACH GAME • FULL COLOUR SCREEN
DISPLAY • FIGHT SCENES • AMAZING PUZZLE OF
KUSLAK • CAN YOU SURVIVE AND FIND KUSLAKS
TOMB.

Full colour Audio Pack £7.50
Trade Enquiries welcome

Mail Order by first class return post.
Cheques/PO to:

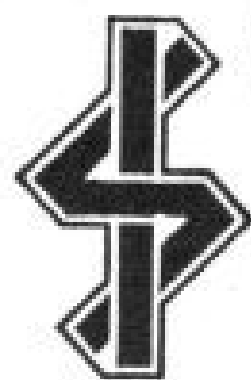

**INTRIGUE
SOFTWARE**



Telephone your order now

Cranbrook Road, Tenterden, Kent TN30 6UJ
Telephone 05806 4726

COMMODORE 64/AMSTRAD/MSX USERS MIDLAND COMPUTER LIBRARY

The first and the largest Commodore 64 library in the world.
Often copied but never equalled.

- 1) All the latest titles on cassette, disc and cartridge.
- 2) Hire your first game absolutely free up to the value of £1.50.
- 3) Life membership £6.
- 4) Hire charge from only £1.25 inc p&p for full 7 days.
- 5) No limit to the amount of games you can hire.
- 6) All games originals with full documentation.
- 7) Games, Business and Educational software.
- 8) Return of post service.
- 9) Lowest new hard and software prices in the UK.
- 10) Join now on 14 day money back guarantee.

Over 1050 different titles in stock. Send cheque or postal
order for £6 with your two selections or large SAE.

Due to continual expansion we are moving to much larger
premises at:

28 COLLEGE STREET, Dept CVG,
WORCESTER, WR1 2LF.
TELEPHONE: Worcester 0905 611072

COMPUTER & VIDEO GAMES

ABC FIGURE JULY-DEC

1984

95,247

ZOOMSOFT

COMPUTER SOFTWARE SPECIALISTS

COMMODORE 64

	cass	disk
Pacman	9.95	14.95
Pole Position	9.95	12.95
Zork I	N/A	11.95
Zork II	N/A	11.95
Zork III	N/A	11.95
Starcross	N/A	11.95
Suspended	N/A	11.95
Deadline	N/A	11.95
Mask of the Sun	N/A	28.95
Cutthroats	N/A	29.95
Suspect	N/A	39.95
Boulder Dash	7.25	9.95
Flip Flop	7.25	9.95
Dig Dug	9.95	14.95
Pitstop II	9.95	N/A
Fooyan	7.50	8.95
Encounter	9.95	12.95
Tigers in the Snow	14.95	14.95
Battle for Normandy	14.95	14.95
Combat Leader	14.95	14.95
Knights of the Desert	14.95	14.95
Shamus II	9.95	14.95
Spelunker	9.95	12.95
Lode Runner	9.95	12.95
David's Midnight Magic	9.95	12.95
Operation Whirlwind	11.95	14.95
Raid on Bungeing Bay	9.95	12.95
Choplifter	9.95	12.95
Hard Hat Mack	9.95	12.95
Realm of Impossibility	9.95	12.95
Archon	11.95	14.95
Murder on the Zindereuf	11.95	14.95
One-on-One	9.95	12.95
M.U.L.E.	11.95	14.95
Pitstop	8.95	11.95
Dragon Riders of Pern	8.95	11.95
Jumpman	8.95	11.95
Impossible Mission	8.95	11.95
Flyer Fox	9.95	14.95
Jetboot Jack	7.95	N/A
Superbase 64	N/A	84.95
Flight Simulator II	36.95	41.95
S.A.M. (speech)	N/A	41.95
Master Type	ROM	32.75
Master Type	N/A	32.75

All activation and U.S. Gold (disk/cass) titles in stock.

ATARI 400/800/XL

	ROM	cass
Telelink	14.95	
Frogger	14.95	
O Bert	14.95	
Centipede	9.95	
Jungle Hunt	9.95	
Pacman	9.95	
Pengo	9.95	
Donkey Kong	14.95	
Donkey Kong Junior	14.95	
Joust	14.95	
Ms Pacman	14.95	
Pole Position	9.95	
Robertson	14.95	
Dig Dug	14.95	
Miner 0428r	12.95	
Oil's Well	18.95	
BC's Quest for Tyres	18.95	
Pitfall II	14.95	9.99
Decathlon	14.95	9.99
Space Shuttle	14.95	9.99
Bounty Bob Strikes Back	49.95	
Buck Rogers	19.95	
Jaw Breaker	14.95	
A.C.E. Enhancer	7.95	N/A
Fort Apocalypse	8.45	12.55
Shamus	10.95	N/A
Protector	9.95	N/A
Bruce Lee	12.55	12.55
Dallas Quest	N/A	12.55
Solo Flight	12.60	12.60
Spitfire Ace	8.45	11.45
Nato Commander	8.45	11.45
Snokie	8.45	11.45
Mr. Robot	N/A	14.95
Boulder Dash	14.95	14.95
Attack of the Mutant Camels	6.25	N/A
Encounter	8.45	11.45
Ghostbusters	N/A	14.95
Conan The Barbarian	9.95	14.95
F15 Strike Eagle	12.69	12.69
Atari Smash Hits	14.95	17.95
Colossus Chess 3.0	9.95	12.95
Combat Ladder	14.95	14.95
Zaxxon	12.55	12.55
Tale of Berahyae	N/A	14.95

ATARI 400/800/XL

	cass	disk
Lode Runner	N/A	24.95
Mask of the Sun	N/A	29.95
Star Bowl Football	23.00	23.00
Star League Baseball	23.00	23.00
Cutthroats	N/A	29.95
Enchanter	N/A	37.95
Sorcerer	N/A	35.95
Seastalker	N/A	28.75
Graphics Art Department	N/A	29.95
Arcade Construction Set	N/A	29.95
Summer Games	N/A	29.95
Ultima III	N/A	47.95
Dancing Feats (music utility)	N/A	21.55
Combat Leader	14.95	14.95
50 Mission Crush	N/A	33.95
Rails West	N/A	33.95
Flight Simulator II	N/A	41.95
S.A.M. (speech)	N/A	41.95
PM Animator	N/A	25.95
Dark Crystal	N/A	24.95
Night Mission Pinball	24.95	24.95
U.S. Doubler	N/A	69.75
Sparta Dos	N/A	39.95
Basic Debugger	N/A	25.95
Basic Commander	N/A	25.95
Data Manager	N/A	34.95
Data Manager II	N/A	39.95
Data Perfect	N/A	73.75
Atari Writer	ROM	39.95
Home Word	N/A	48.95
Basic XL	ROM	66.95
ACTION	ROM	66.95
Mac 65	ROM	72.90
Mac 65 (with OS/A+)	ROM	57.95
Atari 850 Interface		99.95
The Protect (write to both sides of disk)		9.95
Disk Collector (Catalogue disks)	N/A	9.95

ATARI SOFTWARE
Trade enquires
welcome

ZOOMSOFT

46 HUNTSWORTH MEWS, LONDON NW1 6DB

Plus 100's more titles available. Send S.A.E. for free catalogue or
telephone 01-723 0562 between 10am and 7pm. All cheques,
P/O made payable to Zoomsoft.

COMPETITION



CATCH BREAK FEVER



This up and coming group of break dancers are near the end of a routine in which they have tried to screw themselves into the pavement and have proved that you can ski without snow. They now need a big finish which will impress the judges at the Ellava Wallop Modern Dance Contest.

They have planned a move in which one member in the line drops down onto a shoulder and spins round while two others next door jump over him.

The two who jump land in the same order that they take off in.

They want to repeat this move enough times to end up with the

group lined up to spell their name **KRAZIEST**. Being out of puff and rapidly running out of bars, they'd like to repeat this move as few times as possible. Can you work it out for them?

To record your effort, simply name the pair who are to jump each time and whether they are to jump right or left, as you look at them. Put your best answer on the coupon and post it to Break Fever, *Computer & Video Games*, Priory Court, 30-32 Farringdon Road, London EC1R 3AV. Closing date is May 16th and the editor's decision is final.

The winners will be chosen from those sending in an answer which requires the **least** number of moves.

HERE'S WHAT YOU CAN WIN!

The first prize winner in our great *Break Fever* contest will get a complete Breaking kit. This consists of a set of Breakdancing clothes, including trainers etc, a video of the movie *Breakdance*, the soundtrack album from the film and a copy of the *Break Fever* game of course!

There will be 25 runners up who will get a copy of *Break Fever*, for the Commodore 64, plus a *Breakdance* poster and free membership of the Interceptor Software Club.

So what are you waiting for — start Breaking NOW!

C&VG/INTERCEPTOR BREAK FEVER COMPETITION

My answer is.....

.....

Name.....

Address.....

.....



Now Amstrad gives you over £100 to play with.

The image shows a collection of ten Amstrad software boxes arranged in two rows of five. A diagonal banner on the left side of the grid reads "Software over £100 value". A diagonal banner on the right side of the grid reads "FREE! when purchasing an AMSTRAD CPC 464".

Amsoft HANGAR BY PAUL STEWART	Amsoft BRIDGE-IT BY ENCISOFT	Amsoft EASI-AMWORD Computer wordprocessor BY JUMPER COMPUTING	Amsoft Roland on the Ropes BY INESCOP	Amsoft ANIMAL VEGETABLE MINERAL Can the computer guess the object you've thought of? By Bourne Ed.
Amsoft OH MUMMY BY GEN SOFTWARE	Amsoft Harrier As-back! BY DUREL SOFTWARE	Amsoft The Galactic Plague BY INESCOP	Amsoft Roland in the Caves BY INESCOP	Amsoft SIRIAN'S MARE Which Way Now? By Bourne Educational Software

£239

complete with green screen VDU (GT64)

£349

complete with colour monitor (CTM640)



Join in the fun.

Our CPC 464 User Club is a must for all owners.

As a member, you'll be the first to know about the additions to the range. Hardware and software.

We'll provide you with your own privilege card and send you free, a year's subscription to the Amstrad User magazine packed with programs, features and information.

You can enter competitions for valuable prizes and keep up with all the latest Amstrad developments.

And with the free software pack, we think that's pretty good for starters.



Free software worth over £100 is the name of the game.

Along with your new CPC 464 (colour monitor or green screen VDU) you'll receive a software starter pack of 12 (yes, twelve) cassettes absolutely free.

There's something for everyone. From Roland-on-the-Ropes to Easi-Amword word processing.

That's *one* good reason for making Amstrad's CPC 464 your new home computer.

revision for exams, cataloguing and budgeting.

And it comes complete and ready-to-go.

Amsoft. A ton of software.

Yes. Now there are over 100 titles from Amsoft and independent publishers. And the list is still growing.

Arcade games, educational programs and business applications – they're all designed to make the most of the CPC 464's impressive graphics, stereo sound and processing abilities.

And with Amstrad's *speedloading* capability, even complex programs can be loaded quickly. The optional disc system will load a game in around 6 seconds.

When you feel the need to upgrade your Amstrad system to disc drive, just send your favourite Amsoft cassettes to us and we'll send you back the same Amsoft programs on Amsoft disc for just £4.95 per cassette, the price of a blank disc.

When you feel the need to upgrade your Amstrad system to disc drive, just send your favourite Amsoft cassettes to us and we'll send you back the same Amsoft programs on Amsoft disc for just £4.95 per cassette, the price of a blank disc.

AMSTRAD User club CPC 464

MEMBERSHIP NUMBER _____
REGISTERED NAME _____
EXPIRY DATE _____
NOT TRANSFERABLE - SEE MEMBERSHIP CONDITIONS FOR TERMS OF USE

AMSTRAD

ONE GREAT IDEA AFTER ANOTHER

BOOTS COMET Currys Dixons
Greens John Menzies RUMBELOWS spectrum
WHSMITH WIGFALLS WOOLWORTH AND OTHER COMPUTER STORES

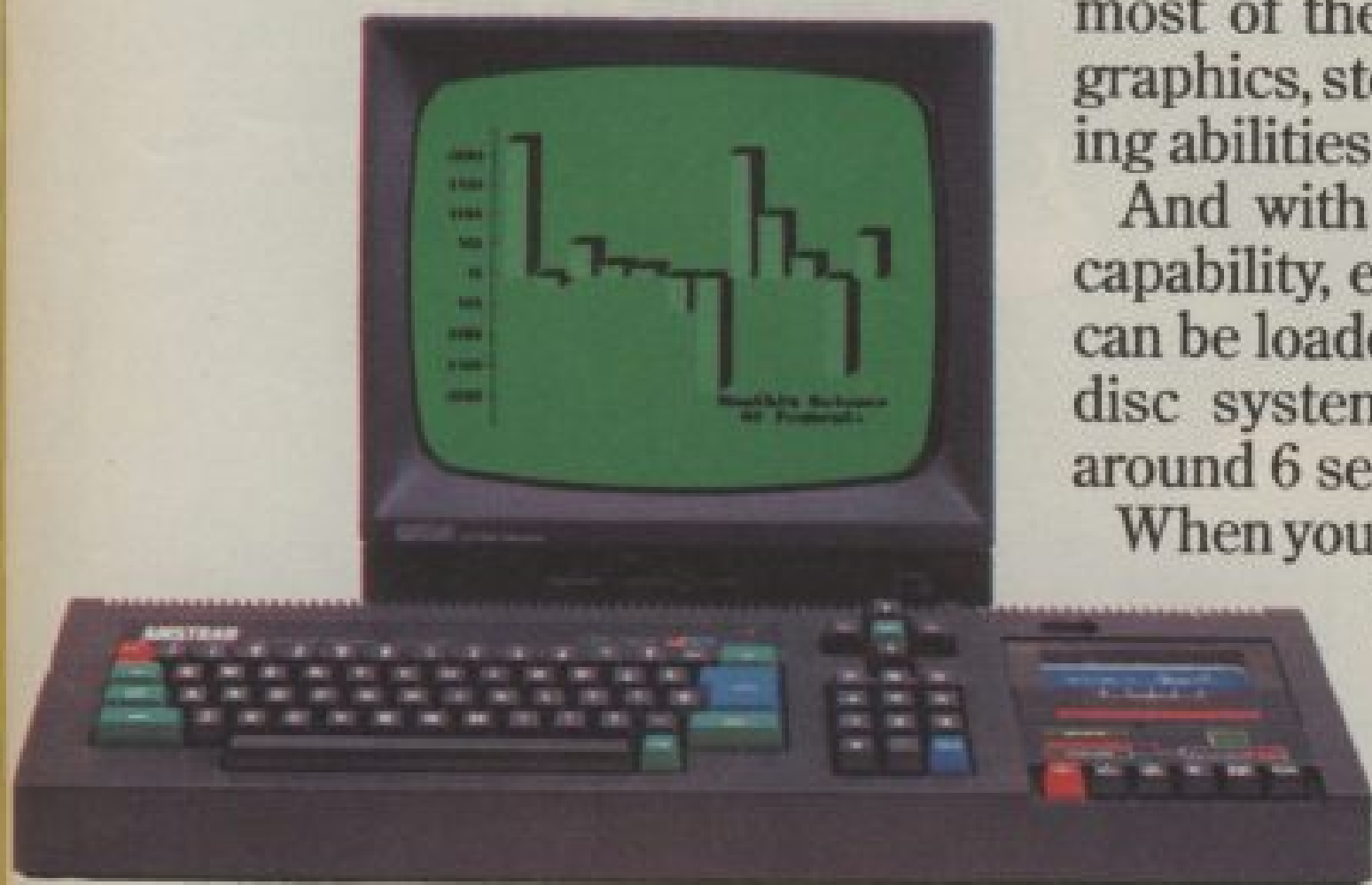

CPC 464 green screen VDU (GT64)

Here are the others.

The CPC 464 comes complete with its own colour monitor or green screen VDU and built-in cassette data recorder. (Optional disc drives are now available with CP/M* and DR. LOGO* supplied as standard.)

It has a typewriter-style keyboard and numeric keypad. 64K of RAM, 32K of ROM and a very fast extended BASIC with real time features.

And it costs a great deal less than the price of a comparable system.

The CPC 464 can handle the trickiest computer games (if you can),

*CP/M and DR LOGO are Trade Marks of Digital Research

I'd like to know more about the exciting CPC 464 complete computer system. Please send me literature right away.

NAME _____

ADDRESS _____

POSTCODE _____

To: Amstrad Consumer Electronics PLC, Brentwood House, 169 King's Road, Brentwood, Essex CM14 4EF.

PRICES CORRECT AT TIME OF GOING TO PRESS. NOT ALL STORES STOCK ALL PRODUCTS.

CVG 5/85

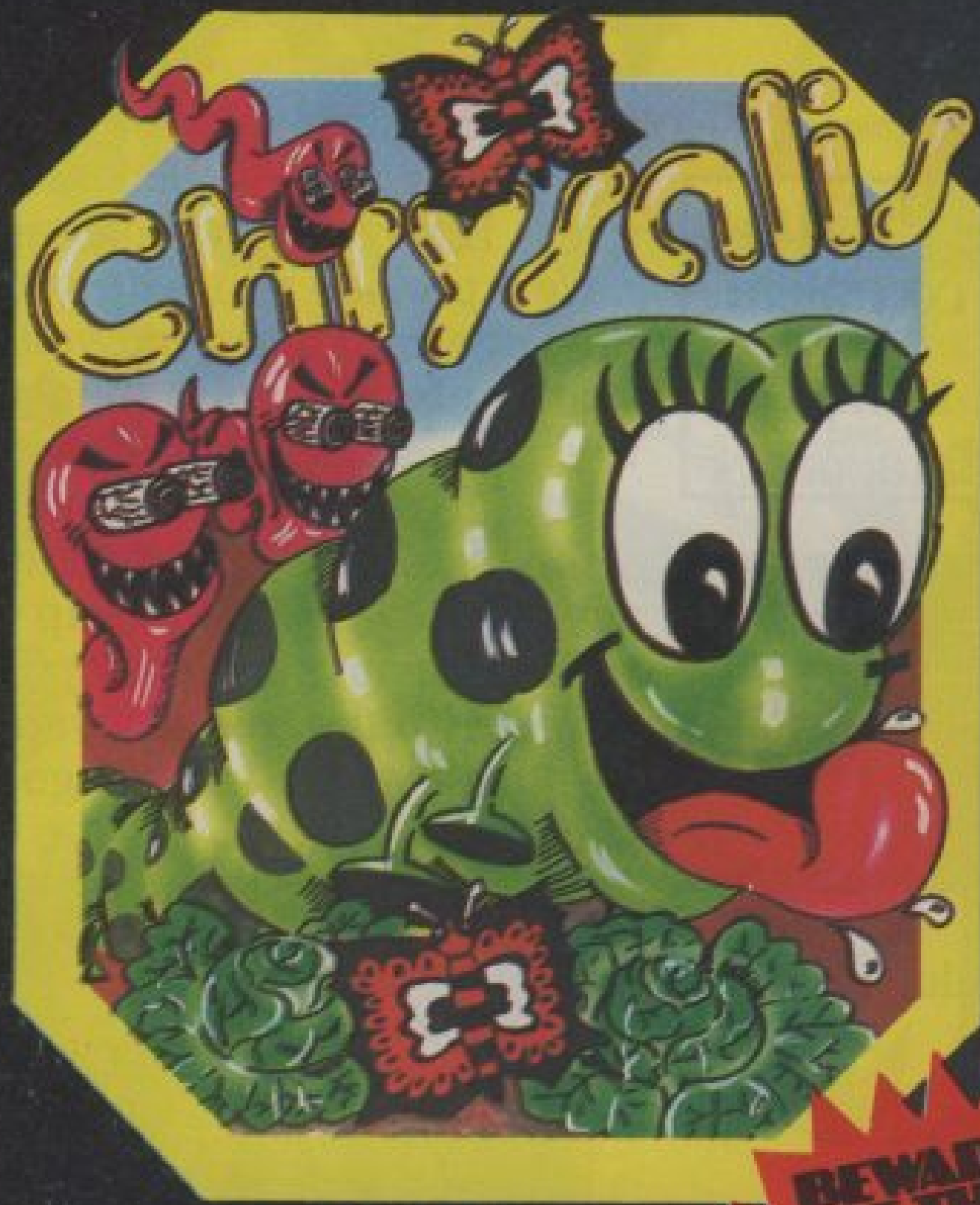

CHRYSALIS...

Super smooth full colour classic arcade action.

BBC...£7.95 Electron...£7.95
MSX...£6.95 Spectrum...£5.95

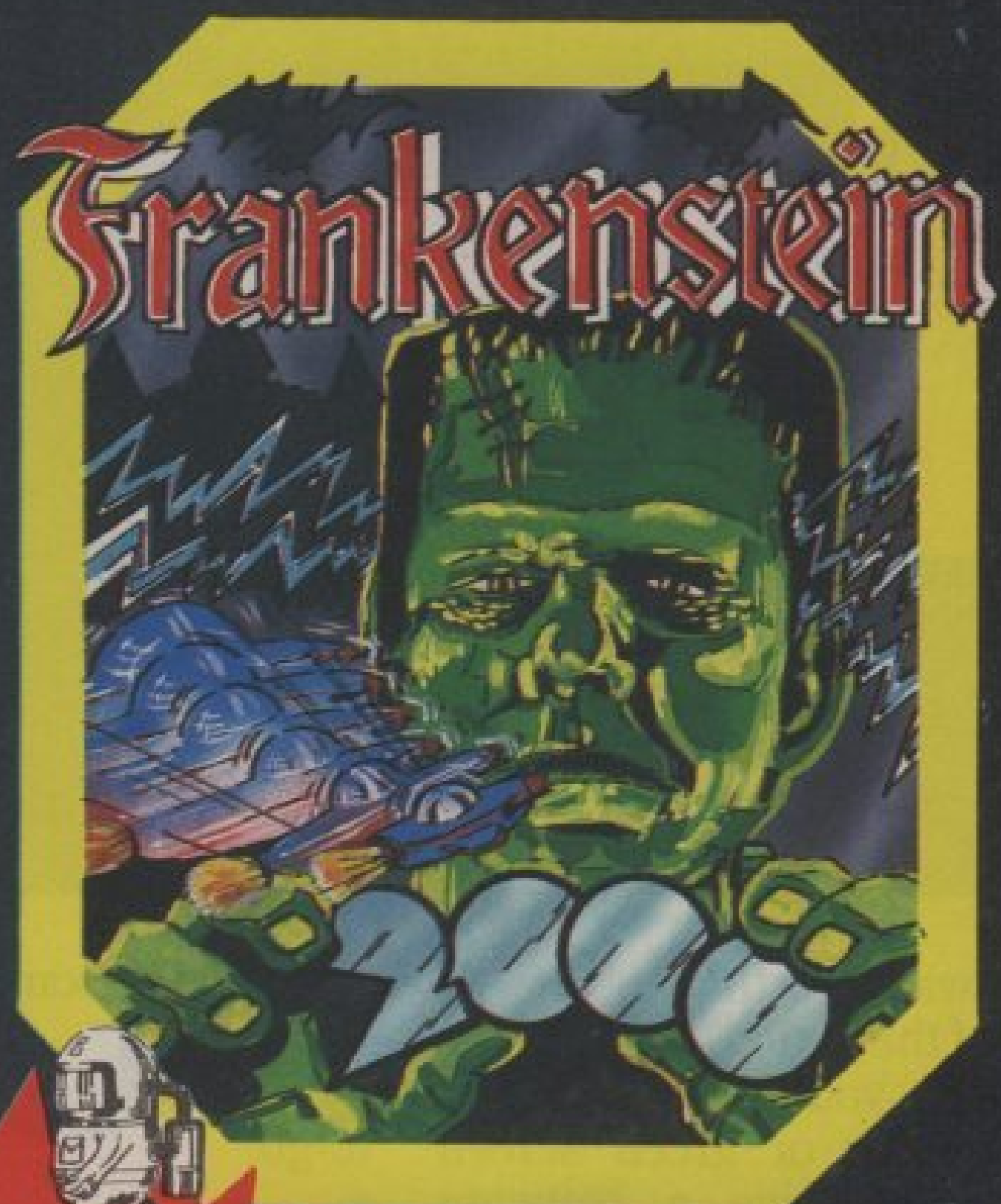

FRANKENSTEIN 2000...

Multi-screen fantasy micro voyage through monsters body. BBC...£7.95 MSX...£6.95
Spectrum...£5.95 Amstrad...£6.95



CONTRAPTION...

Zany Hi-res all action arcade extravaganza

BBC...£7.95 Electron...£7.95 MSX...£6.95 Spectrum...£5.95

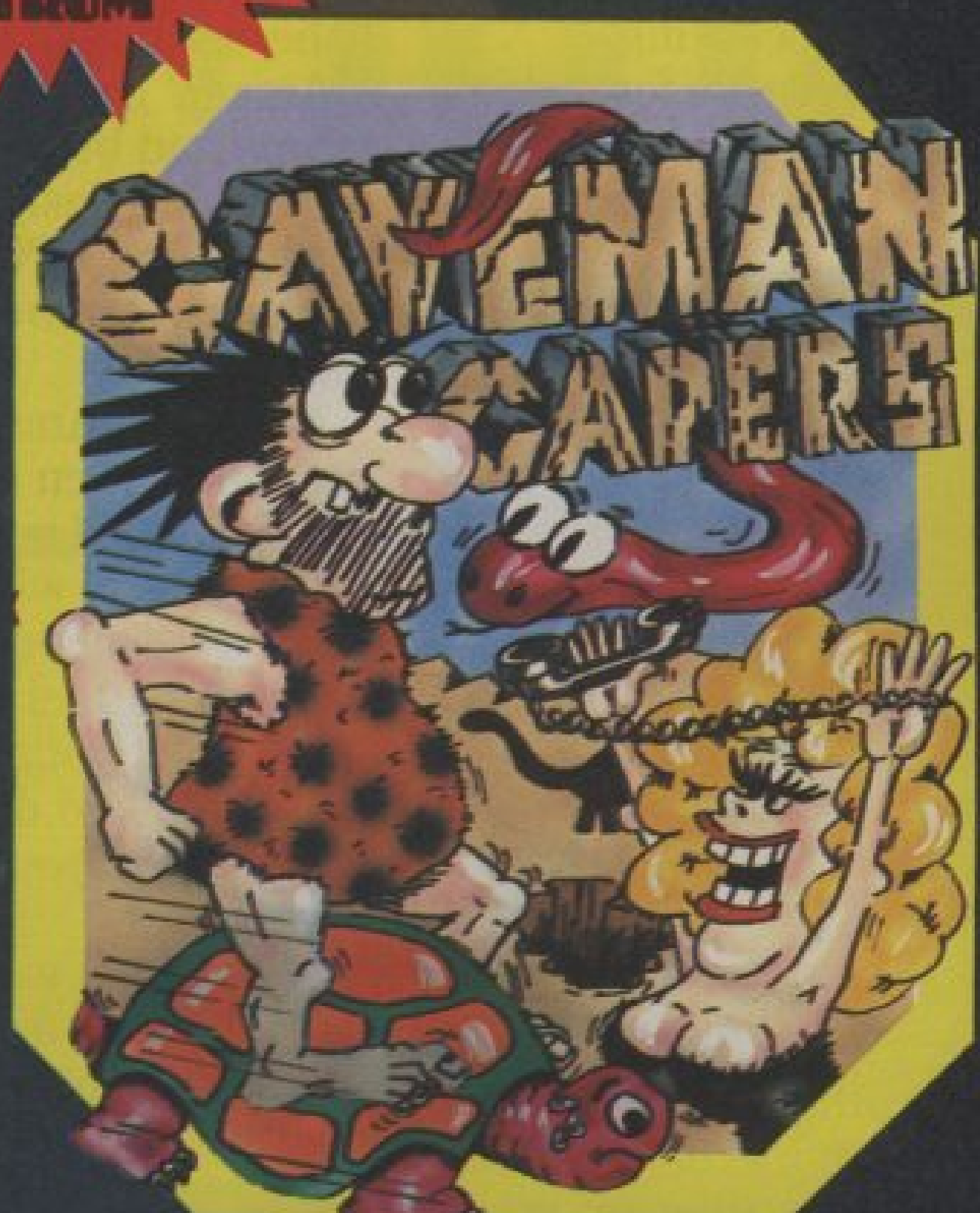

CAVEMAN CAPERS ...

Addictive smooth scrolling fast action arcade fun.

BBC...£7.95 Electron...£7.95 MSX...£6.95 Spectrum...£5.95

Available from most major stockists,
all good computer shops
or direct from us.

To order direct from us:
Send cheque or P.O. payable
to ICON or quote your
Access No.



VAT/PP
Incl.

Tel: (091) 2846966



SOFTWARE

65 HIGH STREET, GOSFORTH,
TYNE & WEAR, NE3 4AA.

NEW!

CAN YOU BEAT BRIAN JACKS?

So you fancy yourself as a sporting superstar do you? Well now *Computer & Video Games* has teamed up with **Martech** and **Rucanor Sporting Goods** to make sure you really look the part when you play at your favourite sport.

We're offering a complete set of sports gear to the top prize winner in our terrific Brian Jacks Superstar Challenge competition!

Martech are releasing a new sports simulation based around the exploits of Brian Jacks, Olympics judo ace and star of many a TV Superstars programme. You could own a Rucanor sports kit, suitable for your favourite sport, just like the gear Brian wears when he's throwing people around in the gym or going for yet another record for arm-dips on TV!

The *Brian Jacks Superstar Challenge* will be available for the Spectrum, CBM 64, BBC, Electron and Amstrad. Ten copies of each version of the game will go to the best ten runners-up who own these machines.

All you have to do is answer the five questions about Brian below, fill in the coupon and rush it to *Computer & Video Games*, Superstar Competition Priory Court, 30-32 Farringdon Lane, London EC1R 3AU. Closing date is April 16th. Normal C&VG competition rules apply. The editor's decision is final and no correspondence will be entered into.

So what are you waiting for!

ABOUT BRIAN JACKS

Brian Jacks has been British Judo Champion an amazing 11 times and Open Champion five times. He has won Olympic and European medals for his sport. He was the youngest sixth Dan in this country and has captained the British International Judo team on several occasions. He became British and European Superstars Champion in 1979 and 1980 following BBC TV's popular sports challenge.

He now regularly appears on children's TV shows, writes for magazines, and performs many fund raising activities, as well as training young would-be judo Superstars. He is a true sporting Superstar!

THE GAME

Martech's new game features eight of Brian Jacks' favourite Superstar events. These are arm-dips, squat thrusts, canoeing, cycling, football, swimming, archery and the 100 metres. Each involves a new challenge to your computer sport skills. You'll need fast reactions and plenty of stamina to beat Brian at his own game! Reckon you are up to it? Then enter our competition today!

THE QUESTIONS

1. What grade does Brian Jacks hold in Judo?
2. What is Brian Jacks' world record for arm-dips on the parallel bars in one minute?
3. How many times has Brian represented Britain in the Olympic Games?
4. Brian has appeared regularly on TV over the last few years. Name three programmes in which he has appeared.
5. What is Brian's favourite fruit?

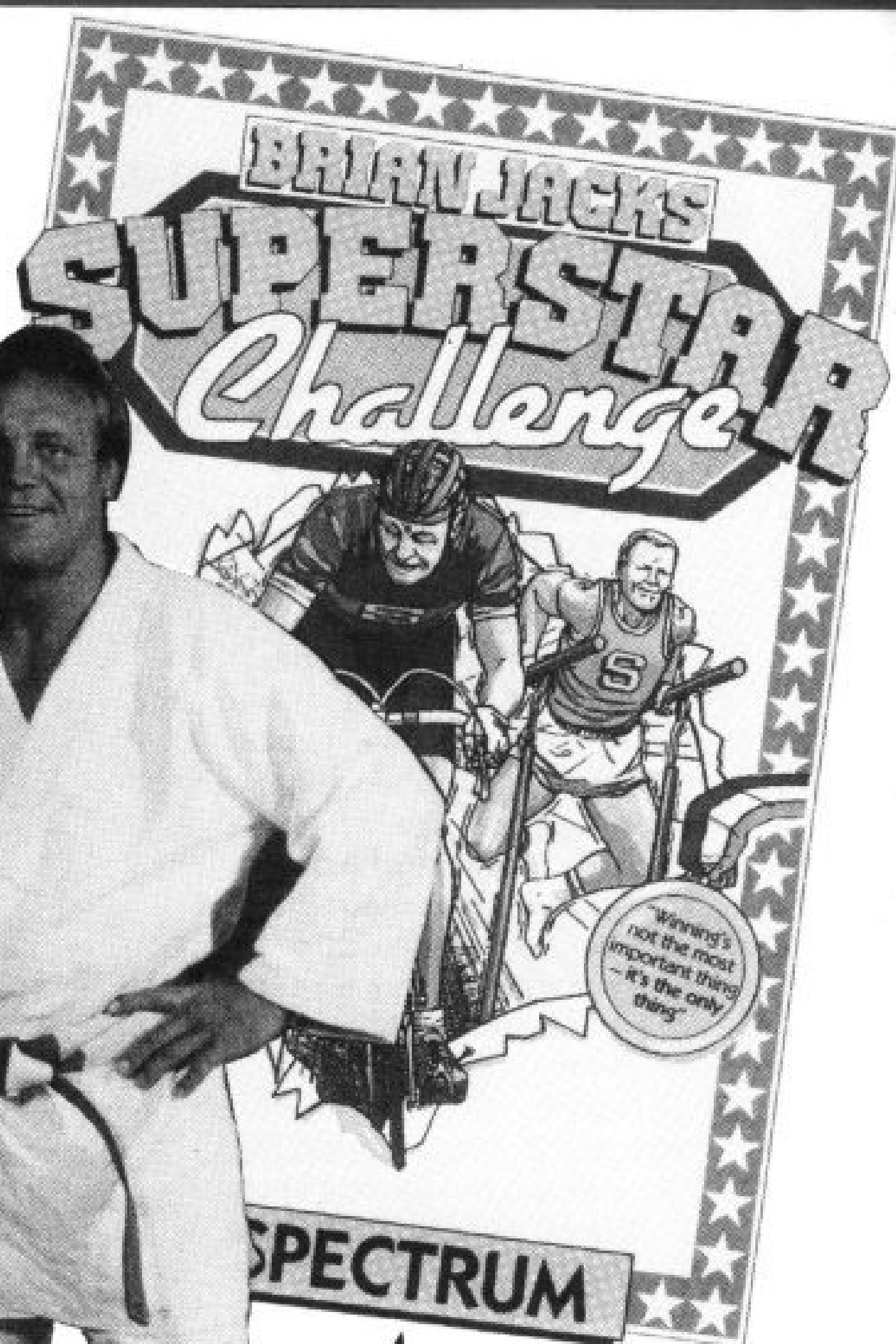

C&VG/MARTECH BRIAN JACKS SUPERSTAR COMPETITION

My answers are:

- 1
- 2
- 3
- 4
- 5

Name:

Address:

.....

Tel:

If I win the top prize, I would like Rucanor sports gear suitable for (tick box):

Athletics Judo Football

Computer I own (tick box)

Spectrum C64 BBC

Electron Amstrad

My favourite sport is:

.....

GAME OF
THE
MONTH

Tom Sato, the man behind the MSX supplement in our December issue, has turned his hand to programming the BBC computer and has come up with some pretty amazin' results.

Smarty Bert is Tom's adaptation of the successful arcade game Q*Bert. Tom's game differs from the original in that, instead of having the same shape to jump across - a pyramid in Q/bert's case, the program presents an ever varying selection of different shapes which you must cross changing the colour of the squares.

Bonus points can also be scored by picking up objects.

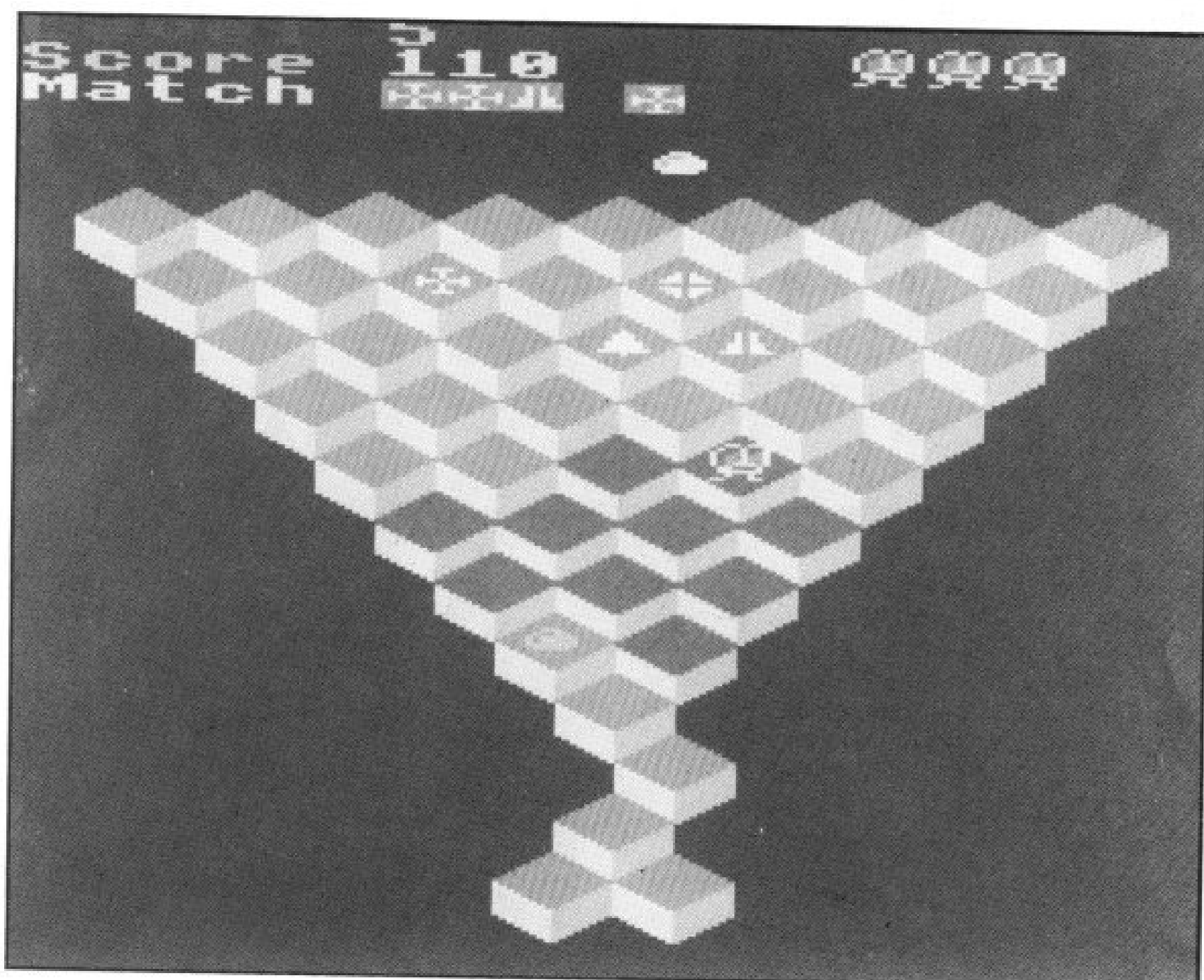

```

100DIM I%(5),J%(5),K%(4),H%(3)
,S$(3),W%:130,R%(3),O%(3),U%(4),
U$(4)
20*K.10 OLD$MRUN$M
30ON ERROR GOTO70
40*TV255
50MODE2
60PROCINIT:GOTO80
70PROCXX
80PROCST
90X%=576:Y%=580
100Z$=INKEY$(10)
110*FX15,1
120IF Z$="" THEN250
130MOVEX%,Y%:PRINTA$:SOUND1,1,
100,3
140IF Z$="/" X%=X%-D%:Y%=Y%-D%
150IF Z$="Z" X%=X%+D%:Y%=Y%-D%
160IF Z$="A" X%=X%-D%:Y%=Y%+D%
170IF Z$=":" X%=X%+D%:Y%=Y%+D%
180P%=POINT(X%+4,Y%-32)
190MOVEX%,Y%:PRINTD$
200G%=(D%*(Y%MOD128)>0)+X%
)DIV128+1+(Y%DIVD%-1)*9:IFW%
?G%>0PROC M
210IFP%=0THEN IF FND(0) THEN70
220S%=S%-(P%=7):T%=T%-(P%=7)
230VDU4:PRINTTAB(6,1);T%"0":VD
U5
240IFS%=F%PROCLP
250IF H%(1)ANDRND(a%)=1PROCS(1
,K%(1))
260IF H%(2)ANDRND(b%)=1PROCS(2
,K%(2))
270IF H%(3)ANDRND(c%)=1PROCS(3
,K%(3))

```

```

280IF H%(1) AND I%(1)=X% AND Y
%=J%(1) THEN IF FND(1) THEN70
290IF H%(2) AND I%(2)=X% AND Y
%=J%(2) THEN IF FND(2) THEN70
300IF H%(3) AND I%(3)=X% AND Y
%=J%(3) THEN IF FND(3) THEN70
310IF C%<>0 THENC%=C%-1:IFC%=0
THENPROCSI(M%)
320IFT%>9% PROCXB
330GOTO100
340DEFPROCS(B%,N%)
350ON N% GOSUB360,390,400
360SOUNDN%,1,120+N%*25,2
370ENDPROC
380PROCSA(B%,N%):RETURN
390PROCSB(B%,N%):RETURN
400PROCSC(B%,N%):RETURN
410DEFPROCSA(B%,N%):MOVEI%(B%)
,J%(B%):PRINTS$(N%):J%(B%)=J%(B%
)-64
420IFRND(2)=1THENA%=-D%ELSEA%=
D%
430IFPOINT(I%(B%)+32+A%,J%(B%)
-32)=0 THEN470
440I%(B%)=I%(B%)+A%
450MOVEI%(B%),J%(B%):PRINTS$(N
%)
460ENDPROC
470IFJ%(B%)=68THENI%(B%)=640:J
%(B%)=900:GOTO450 ELSE A%=-A%:GO
TO440
480DEFPROCSB(B%,N%):IF RND(2)=
1 PROCSC(B%,N%):ENDPROC
490PROCSA(B%,N%):ENDPROC
500DEFPROCSC(B%,N%)

```

SMARTY BERTY

RUNS ON A BBC

BY TOM SATO

```
510IF X%=I%(B%) OR Y%=J%(B%) P
ROCSA(B%,N%):ENDPROC
520A%=D%*( ( I%(B%)>X%)-( I%(B%)<
X%)):Q%=D%*( ( J%(B%)>Y%)-( J%(B%)<
Y%))
530IF POINT(I%(B%)+32+A%,J%(B%
)-32+Q%)=0 PROCSA(B%,N%):ENDPROC
540MOVEI%(B%),J%(B%):PRINTS$(N
%)
550I%(B%)=I%(B%)+A%:J%(B%)=J%(
B%)+Q%
560MOVEI%(B%),J%(B%):PRINTS$(N
%)
570ENDPROC
580DEFPROC M:O%(1)=O%(2):O%(2)=
O%(3):O%(3)=W%?G%+241
590IF R%(1)=O%(1) AND R%(2)=O%
(2) AND R%(3)=O%(3) THEN T%=T%+(
R%(1)-239)*(R%(2)-239)*(R%(3)-23
9):SOUND3,5,100,10 ELSE T%=T%+W%
?G%:SOUND1,4,100,5
600VDU4:COLOUR7:COLOUR132:PRIN
TTAB(10,2)CHR$O%(1)CHR$O%(2)CHR$
O%(3):COLOUR3:COLOUR128:VDU5
610W%?G%=0:ENDPROC
620DEFPROC L:P:L%=L%+1:PROCPY(L%
):PROCFL:PROCSI(1):X%=576:Y%=580
:MOVEX%,Y%:PRINTD$:PROC MU:ENDPRO
C
630DEFPROC SI(A%):M%=A%:I%(A%)=
640:J%(A%)=900:MOVEI%(A%),J%(A%)
640PRINTS$(K%(A%)):H%(A%)=TRUE
:M%=M%+1:IF K%(M%)=0 C%=0:ENDPRO
C
650IF A%=1 C%=d%:H%(2)=FALSE:H
%(3)=FALSE
660IF A%=2 C%=d%:H%(3)=FALSE
670IF A%=3 C%=0
680ENDPROC
690DEF FND(W%):MOVEX%,Y%:PRINTF
$:PROCDE(50):MOVEX%,Y%:PRINTG$:P
ROCDE(50):MOVEX%,Y%:PRINTH$:PROC
DE(50):MOVEX%,Y%:PRINTA$:PROCDE(
50)
700IF W%=0 MOVEX%,Y%:PRINTE$
710IF H%(1) AND W%<>1 MOVEI%(1
),J%(1):PRINTS$(K%(1))
720IF H%(2) AND W%<>2 MOVEI%(2
),J%(2):PRINTS$(K%(2))
730IF H%(3) AND W%<>3 MOVEI%(3
),J%(3):PRINTS$(K%(3))
740PROCFRUITY
750PROCSI(1)
760IF V%=0 THEN:=TRUE
770=FALSE
```

```
780DEFPROC XB:G%=G%+1000:SOUND3
,5,100,30:IFV%=5 T%=T%+50+G%/100
:ENDPROC
790V%=V%+1:PROCFL:ENDPROC
800DEFPROC INIT
810VDU23,224,1,3,7,15,31,63,12
7,255
820VDU23,225,255,127,63,31,15,
7,3,1
830VDU23,226,128,192,224,240,2
48,252,254,255
840VDU23,227,255,254,252,248,2
40,224,192,128
850VDU23,228,0,0,0,0,0,54,73
860VDU23,229,137,137,137,157,9
8,126,36,198
870VDU23,230,0,0,0,0,0,0,52
880VDU23,231,100,64,64,64,28,0
,0,0
890VDU23,232,18,54,54,34,0,0,0
,0
900VDU23,233,0,56,76,190,190,2
54,124,0
910VDU23,234,0,0,48,64,64,0,0,
0
920VDU23,235,0,0,68,40,0,40,68
,0
930VDU23,236,0,0,16,56,56,16,0
,0
940VDU23,237,0,56,124,84,124,6
8,56,0
950VDU23,238,254,252,248,252,2
54,255,206,132
960VDU23,239,127,63,31,63,127,
255,115,33
970VDU23,240,132,206,255,254,2
52,248,252,254
980VDU23,241,33,115,255,127,63
,31,63,127
990VDU23,242,0,8,8,28,119,28,8
,8
1000VDU23,243,0,28,8,73,119,73,
8,28
1010VDU23,244,0,20,20,20,54,54,
119,0
1020VDU23,245,0,20,54,119,0,119
,54,20
1030VDU23,246,0,8,28,28,62,62,1
27,8
1040VDU23,247,0,99,103,40,20,10
,115,99
1050VDU23,248,0,8,28,20,54,34,1
19,62
1060VDU23,249,0,38,73,84,42,21,
73,50
```

```

1070A$=CHR$18+CHR$0+CHR$1+CHR$2
24+CHR$226+CHR$10+CHR$8+CHR$8+CH
R$225+CHR$227
1080B$=CHR$18+CHR$0+CHR$4+CHR$2
24+CHR$226+CHR$10+CHR$8+CHR$8+CH
R$225+CHR$227+CHR$18+CHR$3+CHR$3
+CHR$8+CHR$8+CHR$226+CHR$18+CHR$
3+CHR$2+CHR$224+CHR$18+CHR$3+CHR
$3+CHR$10+CHR$8+CHR$8+CHR$225+CH
R$18+CHR$3+CHR$2+CHR$227+CHR$11+
CHR$11
1090C$=CHR$18+CHR$0+CHR$3+CHR$2
28+CHR$8+CHR$10+CHR$229+CHR$8+CH
R$11+CHR$18+CHR$0+CHR$1+CHR$230+
CHR$8+CHR$10+CHR$231+CHR$8+CHR$1
8+CHR$0+CHR$4+CHR$232
1100D$=A$+CHR$25+CHR$0+CHR$160+
CHR$255+CHR$48+CHR$0+C$
1110E$=CHR$18+CHR$0+CHR$0+CHR$2
24+CHR$226+CHR$10+CHR$8+CHR$8+CH
R$225+CHR$227
1120F$=A$+CHR$10+CHR$25+CHR$0+C
HR$160+CHR$255+CHR$48+CHR$0+CHR$
18+CHR$0+CHR$6+CHR$237
1130G$=A$+CHR$10+CHR$25+CHR$0+C
HR$160+CHR$255+CHR$48+CHR$0+CHR$
18+CHR$0+CHR$7+CHR$236
1140H$=A$+CHR$10+CHR$25+CHR$0+C
HR$160+CHR$255+CHR$48+CHR$0+CHR$
18+CHR$0+CHR$3+CHR$235
1150VDU19,14,3,0,0,0,
1160VDU19,11,3,0,0,0,
1170VDU19,13,6,0,0,0,
1180VDU19,8,6,0,0,0,
1190VDU19,15,7,0,0,0,
1200VDU19,10,7,0,0,0,
1210S$(1)=CHR$25+CHR$0+CHR$32+C
HR$0+CHR$246+CHR$255+CHR$18+CHR$
3+CHR$10+CHR$233+CHR$8+CHR$18+CH
R$3+CHR$8+CHR$234
1220S$(2)=CHR$25+CHR$0+CHR$32+C
HR$0+CHR$246+CHR$255+CHR$18+CHR$
3+CHR$9+CHR$233+CHR$8+CHR$18+CHR
$3+CHR$8+CHR$234
1230S$(3)=CHR$25+CHR$0+CHR$32+C
HR$0+CHR$246+CHR$255+CHR$18+CHR$
3+CHR$11+CHR$233+CHR$8+CHR$18+CH
R$3+CHR$8+CHR$234
1240PROCXI
1250ENDPROC
1260DEFPROCST:CLS:PROCTT:T%=0:S
%=0:V%=6:D%=64:9%=1000
1270L%=GET-48:IF L%<=0 OR L%>=1
0 THEN 1270
1280PROCPY(L%):PROCFRUITY:PROCS
I(1):PROCMU:ENDPROC
1290DEFPROCPY(A):A=A*2-1:CLS:VD
U4
1300COLOUR5:PRINTTAB(0,0)"Level
".
1310COLOUR6:PRINT:L%

```

```

1320COLOUR2:PRINTTAB(0,1)"Score
";
1330COLOUR3:PRINT:T%"0"TAB(0,2)
"Match ";
1340F%=-1:S%=0:VDU5
1350FOR X=A TO A+11
1360Z=X MOD 9
1370IF ((X DIV 9) MOD 2)=1 THEN
Z=9-Z
1380MOVE640-64*Z,900-64*(X-A+1)
1390FORI=1TOZ:PRINTB$;:F%=F%+1
1400NEXT:NEXT
1410PROCSHA
1420VDU4:COLOUR7:COLOUR132:PRIN
TTAB(6,2)CHR$(R%(1))CHR$(R%(2))CHR$(R
%(3)):COLOUR128:PRINTTAB(9,2)" ":
COLOUR3:COLOUR128:VDU5
1430A=L%:RESTORE1500
1440IF A>10 A=4+((A-10) MOD 6)
1450FORX=1TOA:READ K%(1),K%(2),
K%(3):NEXT
1460A=L% DIV10:RESTORE1500
1470IF A>10 A=4+((A-10) MOD 6)
1480FORX=1TOA:READ c%,b%,a%:NEX
T:a%=5-a%:b%=5-b%:c%=5-c%:d%=a%*
b%*c%/2
1490ENDPROC
1500DATA1,1,0,1,2,0,1,1,1,1,1,2
,2,1,1,1,2,2,1,2,3,2,2,3,2,3,3,3
,3,3
1510DEFPROCFRUITY:V%=V%-1:PROCF
L
1520X%=576:Y%=580:MOVEX%,Y%:PRI
NTD$:ENDPROC
1530DEFPROCFL
1540*FX15,1
1550VDU4
1560PRINTTAB(13,0)" "TAB(
13,1)" "
1570VDU5
1580IFV%=1ENDPROC
1590FORX=1TOV%-1:MOVE800+80*X,1
020:PRINTC$:NEXT
1600ENDPROC
1610DEFPROCSHA:DT%=0:DN%=0:O%(1
)=0:O%(2)=0:O%(3)=0:GCOL0,7
1620FORI=0TO130:W%?I=0:NEXT
1630IFL%<11 THEN1650
1640FORI=1TO10:AS%=RND(8):PROCO
S:NEXT:ENDPROC
1650H%=1:RESTORE1720
1660REPEAT
1670READ AS%
1680IF AS%=-1 H%=H%+1:GOTO1670
1690IFL%=H%PROCOS
1700UNTIL H%=L%+1
1710ENDPROC
1720DATA1,1,1,2,-1,1,1,2,3,-1,1
,2,2,3,-1,1,2,3,4,-1,2,2,3,4,5,-
1,2,3,4,5,5,-1,3,4,5,5,5,6,-1,3,
4,5,6,7,8,-1,4,5,6,7,8,1,2,-1,5,
6,7,8,1,1,1,1,-1

```

Hi ... Rat Fans

Roland's Ratrace



Yeh, it's me, your favourite Superstar, in my first-supa-game! I'll need all your help to find my furry friends in the nasty Rodent World where all kinds of monster meanies live. Hurry now, and I'll see you on your screen, from your cuddly, adorable me, Roland Rat, Superstar.

NEW

SPECTRUM 48k

6.90

ocean

COMMODORE 64

7.90

Ocean House, 6 Central Street, Manchester, M2 5NS. Telephone 061 832 6633. Telex 669977

Ocean Software is available from selected branches of **WOOLWORTH**, **WHSMITH**, **LASKYS**, **Rumbelows**, **COMET**, Spectrum Shops and all good software dealers. Trade enquiries welcome.

*it's
brill!*

Big Five Software and U.S. Gold proudly present the sequel to the world's most popular arcade game.

Bounty Bob returns in this new and exciting follow-up adventure to Miner 2049er. This time around it's even tougher than before and Bob needs your help more than ever to guide him through the mines. The mutant organisms have multiplied and over-run the mine entirely, making it extremely difficult to survive the hazards of the underground passageways! Using the high-powered special equipment is Bob's only hope of achieving his objective of securing the mine and defeating the plans of the evil Yukon Yohan!

Bounty Bob Strikes Back features 25 of the greatest platform screens ever produced including: Grain Elevators, Super Energy Food Bars, Gravity Lifts, Acid Rain, Suction Tubes, Hydraulic Lifts, Mobile Suction Units, Transporters, Cannons, Utility Hoists, Pulverisers, Moving Weirdos, Mutant Organisms, Treats, the greatest High Score Factory in computer history and much, much more!

Special features include:

Multi-Channel Music, Game Adjustment Screen, Automatic Demo Mode, Two-Player Mode with dual joystick capability, Level Warp ability.

Available for: Atari and Commodore 64.

Coming soon on: Amstrad, BBC and Spectrum.



This is what they said about Miner 2049er...

'Miner 2049er emerged as the unequalled popular choice among Arkie (like Oscars) voters. Going strictly by the popular vote it would have, or come close to, copping no fewer than three 'Game of the Year' Arcade Awards.

'The Arcade Awards Judging Committee having heard the voice of the gaming nation, recommended that a new award be created this year and given to Miner 2049er. It therefore gives us great pleasure to announce the institution of the 1984 Grand Arcade Award for the Best Electronic Game of the Year.'

Editors of Electronic Games

'Last year Miner 2049er won a landslide victory as Electronic Game of the Year. Now this delightful multi-screen climbing and jumping game has ascended the next rung on the ladder of fame in the same high style by coasting to a triumph in the Hall of Fame voting. Miner 2049er has historical significance as well as intrinsic value. It was the first electronic game designed for the home market which could be played on almost every videogame and computer system. The multi-publisher licensing made Miner the first home game to acquire a hobby-wide reputation on a par with leading games found in the family amusement centres. Bounty Bob Lives!'

Electronic Games Hall of Fame

'When I saw the result - Miner 2049er - I said "Let me take it to everybody in the world." The response has been amazing. We collected the biggest advance orders ever.'

Barry Friedman -
International Computer Group U.S.A.

Bounty Bob will leave them speechless!

U.S. Gold is available from all leading computer stores, and selected branches of:

BOOTS · W.H.SMITH · JOHN MENZIES · WOOLWORTH · WILDINGS

Dealers! For information on how to become a U.S. Gold Stockist contact Centresoft, Lightning, Microdealer, Tiger and other leading distributors or

write to U.S. Gold Limited, Unit 10, The Parkway Industrial Estate, Heneage Street, Birmingham B7 4LY.

Telephone: 021-359 3020. Telex: 337268.



BOUNTY BOB STRIKES BACK!



Bill Hogue

BIG FIVE

SOFTWARE

Could YOU be a Software Star?

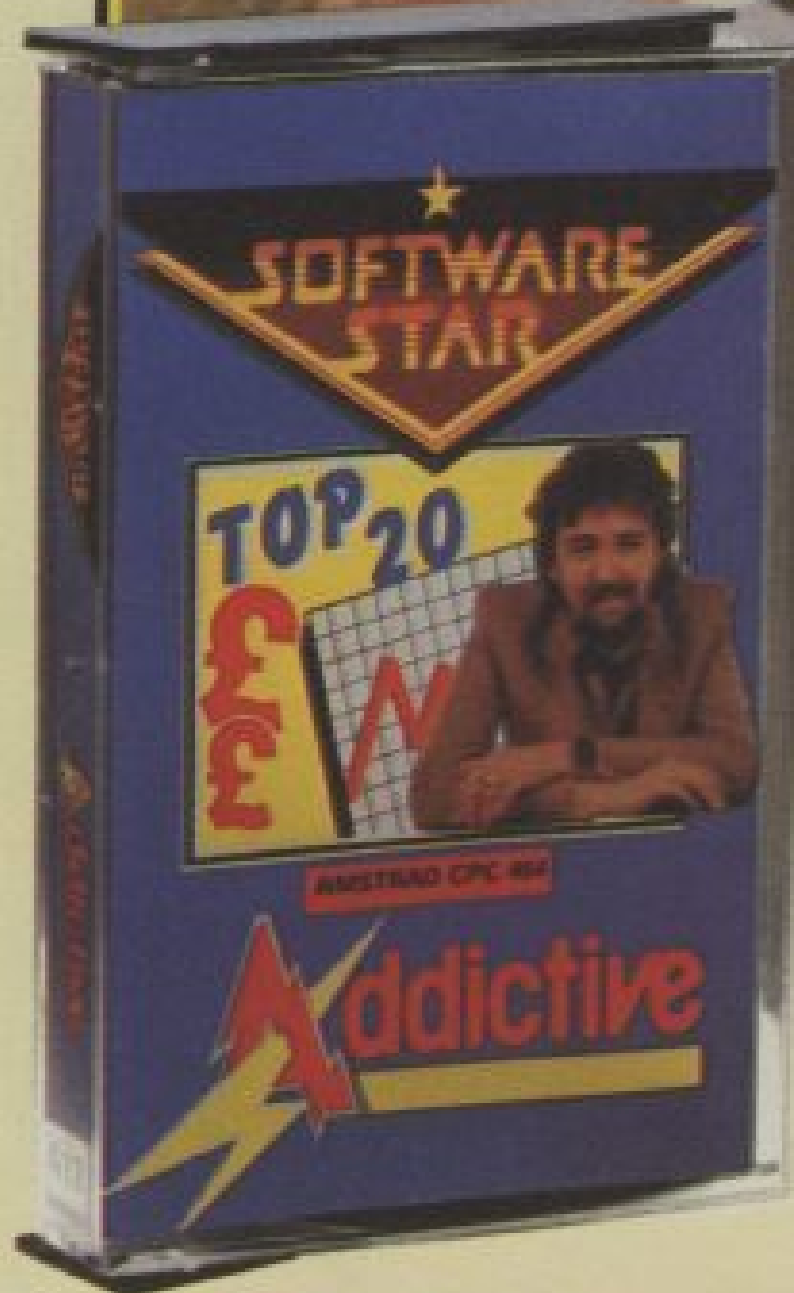
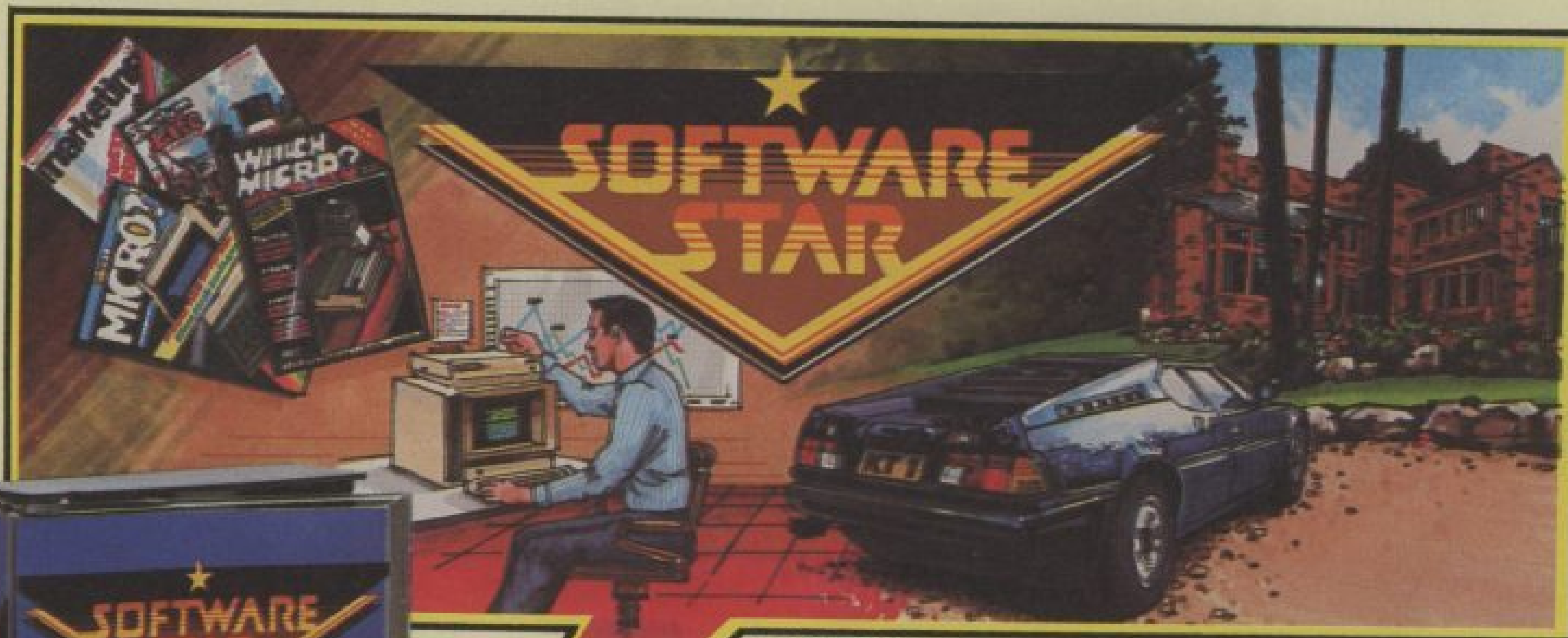

In **SOFTWARE STAR** you take control of a software company and aim to take it along the precarious path to success. On the way you meet with staff problems, decisions regarding advertising, expenditure, finance and game launches, but your business awareness together with a few gambles paying off will make you a **SOFTWARE STAR**.

"It carries the Kevin Toms hallmarks of attention to detail and carefully tuned difficulty"

Popular Computing Weekly, February 1985

"The game can be incredibly subtle"

Pick of the Week, Popular Computing Weekly, February 1985

Available... Spectrum 48K £6.95... Commodore 64 £7.95... Amstrad CPC 64 £7.95.

Software Star is a strategy game not a graphical game.

ALSO AVAILABLE

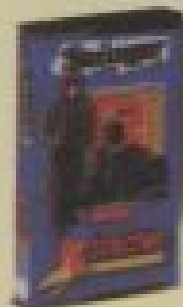

STRINGER

Stringer is an arcade adventure game in which you are a press photographer set the task of snatching a shot of a Film Star in an hotel. The game is tantalisingly playable, graphically excellent and, of course - Addictive!
Available... Commodore 64 £6.95



FOOTBALL MANAGER - The All Time Classic

Available... Spectrum 48K £6.95... Commodore 64 £7.95... Amstrad CPC 64 £7.95... BBC 'B' £7.95... Electron £7.95... Oric-1/Atmos £7.95... Dragon £5.95... Vic 20 £5.95... ZX 81 £5.95

When you open an Addictive Game, there's a new world of discovery waiting for you.



To: Addictive Games Ltd, 7a Richmond Hill, Bournemouth, Dorset BH2 6HE

Please send me:

- cassette(s) of Software Star for (computer)
- cassette(s) of Stringer for (computer)
- cassette(s) of Football Manager for (computer)

I enclose cheque/postal order for * £.....

Please debit my Access card No.....

Name * Delete as applicable

Address

Postcode..... Tel:

Access orders can be telephoned through on (0202) 296404



```

1730
1740DEFPROCOS
1750AX%=RND(8):AY%=RND(11)
1760IF POINT(64+AX%*128+64*(AY%
MOD 2)=0),58+AY%*64)=0 OR W%?(
AX%+AY%*9)<>0 OR(AX%=5 AND AY%=8
) THEN1750
1770MOVE32+AX%*128+64*(AY% MOD
2)=0),58+AY%*64:PRINTCHR$(241+A
S%)
1780W%?(AX%+AY%*9)=AS%
1790IFDT%<3THENDT%=DT%+1:R%(DT%
)=AS%+241
1800ENDPROC
1810
1820DEFPROCXI:RESTORE1830:FORI=
0TO4:READU%(I),U$(I):NEXT:ENDPRO
C
1830DATA2000,ALPHA,1500,BETA,10
00,GAMMA,500,DELTA,100,EPSILON
1840DEFPROCXX:CLS:VDU5:GCOLOR,2:
FORI=1TO9:MOVE50,1052-I*96:PLOT1
,1200,0:MOVE50,1044-I*96:PLOT1,1
200,0:NEXT
1850I=-1:REPEAT:I=I+1:UNTILI=4
OR T%>U%(I)
1860IFU%(4)>T% THENA%=TRUE:GOTO
1920 ELSEA%=FALSE
1870IF I=4THEN1910
1880FOR A=3 TO I-1 STEP-1:IF A=
-1THEN1900
1890U%(A+1)=U%(A):U$(A+1)=U$(A)
1900NEXT
1910U%(I)=T%:U$(I)=""
1920MOVE250,810:GCOLOR,1:PRINT"S
MARTY BERTY":MOVE258,818:GCOLOR,3
:PRINT"SMARTY BERTY"
1930FORA=1TO3STEP2:FORX=0TO4:GC
OLOR,A:MOVE110+A*3,610-X*96+A*3:P
RINT;X+1;" "U%(X)"0 ":MOVE720+A*
3,610-X*96+A*3:PRINTU$(X):NEXT:N
EXT
1940GCOLOR,2
1950IF A% THEN1990
1960MOVE100,150:PRINT"Input you
r name"
1970MOVE100,80:INPUTn$:IF LEN(n
$)>8 n$=LEFT$(n$,8)
1980U$(I)=n$:T%=0
1990MOVE300,50:PRINT"Press a ke
y":A=GET:ENDPROC
2000DEFPROCDE(X):T=TIME:REPEAT:
UNTILTIME=T+X:ENDPROC
2010
2020DEFPROCTT:VDU5:GCOLOR,2
2030FORI=1TO6:MOVE200,1052-I*96
:PLOT1,880,0:MOVE200,1044-I*96:P
LOT1,880,0:NEXT

```

```

2040MOVE250,900:GCOLOR,1:PRINT"S
MARTY BERTY"
2050MOVE570,710:PRINT"by"
2060MOVE400,514:PRINT"T . Sato"
2070MOVE258,908:GCOLOR,3:PRINT"S
MARTY BERTY"
2080MOVE578,718:PRINT"by"
2090MOVE408,522:PRINT"T . Sato"
2100MOVE580,350:PRINTB$:MOVE610
,375:PRINTC$
2110VDU4
2120COLOUR7:COLOUR132:PRINTTAB(
4,21)"A"TAB(15,21)"*"TAB(8,26)"Z
"TAB(11,26)"/"
2130COLOUR2:COLOUR128:PRINTTAB(
5,22)CHR$238TAB(14,22)CHR$239TAB
(7,25)CHR$241TAB(12,25)CHR$240
2140COLOUR9:PRINTTAB(3,29)"InPu
t level 1-9"
2150ENDPROC
2160DEFPROCUMU
2170ENVELOPE1,1,3,2,-2,6,6,6,10
0,0,0,-5,100,0
2180ENVELOPE3,4,0,0,0,0,0,0,126
,-5,-3,-1,126,110
2190ENVELOPE4,3,-32,-14,-49,75,
63,73,9,5,-8,-4,126,126
2200ENVELOPE5,3,27,7,43,67,74,2
16,10,1,0,-5,126,126
2210ON RND(4) GOTO2220,2230,224
0,2250
2220RESTORE2330:GOTO2260
2230RESTORE2340:GOTO2260
2240RESTORE2350:GOTO2260
2250RESTORE2360
2260REPEAT:READ A%
2270IF A%=0THEN2290
2280SOUND1,3,A%,4:SOUND2,3,A%,3
:SOUND2,0,A%,1:SOUND3,3,A%+1,3:S
OUND3,0,A%,1
2290UNTIL A%=0
2300PROCDE(57)
2310*FX15,0
2320ENDPROC
2330DATA 101,109,101,109,101,10
9,101,109,117,121,117,121,117,12
1,117,121,129,137,129,137,129,13
7,129,137,149,149,145,129,149,0
2340DATA 101,149,101,149,101,14
9,145,109,145,109,145,109,117,13
7,117,137,117,137,129,121,117,10
9,101,149,101,0
2350DATA 101,117,129,117,109,12
1,137,121,101,117,129,117,101,0
2360DATA 149,101,149,101,149,10
1,109,145,109,145,109,145,117,13
7,117,137,117,137,149,149,145,13
7,129,149,101,0
2370REM SMARTY BERTY
2380REM (C) T.SATO 1983

```

Minder

Available across a range of micro computers.



dktronics
the games name

Minder is a Euston Films Production for THAMES TELEVISION
• Created by Leon Griffiths . Produced by Lloyd Shirley and George Taylor •

PROFESSOR VIDEO'S



GAMES WORKSHOP

Welcome to the workshop! Hundreds of you rushed to Richard Napier's aid after last issue's *Pyjamarama* hints. Richard couldn't work out the final stages of the game. But now, with your help, he should be well on the way to waking Wally up!

PYJAMARAMA

The Prof had to choose just one person from the many *Pyjamarama* maniacs out there for the purposes of the workshop — and he is Rupert Hinds of Lower Sunbury, Middlesex.

Rupert says that, in order to de-activate the magnetic lock, you must first get the magnet which can be found in the chest under the kitchen table.

- Get the driving licence from the first room you enter on level one. Then go out onto the roof via the room with a pyramid of tea chests. Walk right until you pick up the ignition key.
- Go to level four and slide down the bannisters by grabbing a rope. This will exchange the key for a crash helmet.
- With the crash helmet and the library book go to the library on level two (just before the lift room) and jump onto the table. You can now walk across the table and pick up the scissors.
- Go to level four and get the conveyor belt controller. You should now have the scissors and the controller, OK?
- Enter the room with the HELP button and turn the HELP button ON.
- Now, as quickly as possible, take the lift from level four to level three. Enter the room with the plants and fall through the hole in the floor.
- You should now be standing next to a balloon. Walk towards it and you will be taken up a series of ledges. Move along these until you can jump onto a tea chest, which has been activated by the HELP button. Jump from the chest and you will be able to collect the chest key. Go to the kitchen on level two and walk past the chest. You should now have the magnet.
- Take the magnet — with a full can of fuel, as explained by Richard last issue — and go to the moon on the rocket.
- When you arrive on the moon, walk to the door on the far right. Enter and switch off the magnetic lock by jumping towards the button. Now, with the lock switched off, collect the clock key and return home.
- Go to level four and enter the bedroom with the alarm clock in. Walk to the alarm clock and ... YOU'VE DONE IT!

Thanks Rupert!

SKOOL DAZE

David Leak from Chasetown, Staffordshire has been doing his homework on *Skool Daze*.

- To collect all the shields on the top floor, simply jump at them while the teachers are looking elsewhere.
- All the shields on the second level can be reached by knocking down your fellow pupils and jumping onto them to get the extra height to reach them.

● The shields on the lowest level can only be reached by knocking down the teachers and bouncing a pellet from the catapult off their heads! Please don't attempt this in real life ...

AIRWOLF

D. Messenger, C. Smith and M. Trinder from Enysham, Oxfordshire have been zapping around in *Airwolf*.

- Obstacle 1 (Screen 2 "wall"): Don't try to shoot the top row of bricks. Shoot the three rows below.
- Obstacle 2 (Screen 3 "wall"): Position your *Airwolf* with its nose facing out of the screen before you start firing. You need to remove three rows of bricks.
- Obstacle 3 (Screen 6 "rays"): Enter screen six and hover between the two rays. As soon as the one on the right has fired once, go diagonally down to the right to enter screen five.
- Obstacle 4 (Screen 5 "red box"): When you enter screen five, you will think that you have to go into the small cave to shoot the small red box — DON'T!
- Obstacle 5 (Screen 6 "rays"): Re-enter screen six diagonally upwards. Go straight past the second ray and enter screen seven.
- Obstacle 6 (Screen 7 "lasers"): As soon as you enter screen seven, go diagonally past the first laser and wait for the second laser to light up.
- Obstacle 7 (Screens 8 and 10 "cannons"): Enter screen 10 and hover near to the left side of the cannon until it lowers its barrel toward you. Make sure it is shooting to the left before you move over it. Once you are clear of the first cannon, go straight past the second cannon and hover at the bottom of the screen and shoot the red box. Go back up to screen seven and then straight back down to screen 10.
- Obstacle 8 (Screen 10 — the hardest!): Shoot away the wall below the laser and get ready to go down. Hover near the centre of the screen with the cannon firing upwards.
- Obstacle 9 (Screens 12 "rays, laser and red box"): Go down until you are between two rays — wait until the second one stops firing then continue down. Shoot the red box and hover until the second ray stops again. Go up until you reach the laser, hover close to it and wait until it has fired three times before moving up.
- Obstacle 10 (Screen 9 "laser"): Go back past the two cannons in the same way as before. Wait until the laser goes out and enter screen eight.
- Obstacle 11 (Screen 8 "robot wall"): Wait in the entrance of screen eight until the "robot" fires. Quickly go to the other side of the room and fire away two bricks. Go back to the entrance. You must remove eight bricks from the four rows nearest on the left.
- Obstacle 12: Pass the laser, wait until the flying saucer has passed and then go into the space above the saucer's range. Go to the right and while firing move left. Before you do this, remove the two layers of bricks you can blast from your starting position. You must then go down to hover near the bottom of the screen. When you have done this, you must collect the scientist.

It's up to you to find your way out!

SURVIVE THE JOB JUNGLE!

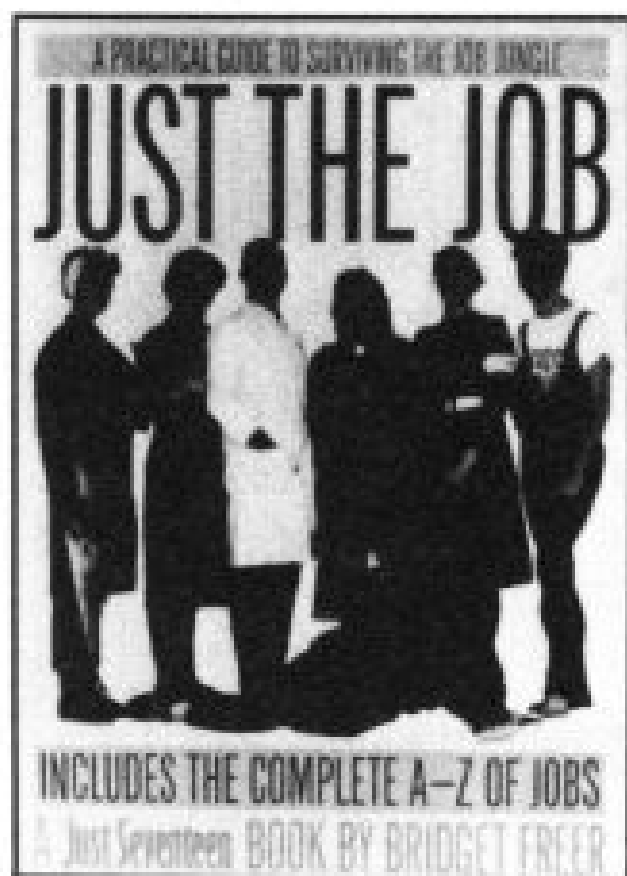

Choosing the right job
Writing application letters
Setting up your own business
College courses and further education
How to handle job interviews
Plus the complete A-Z of jobs

Available from all good bookshops from May 10th or write to EMAP Books,
Bushfield House, Orton Centre, Peterborough, PE2 0UW, enclosing cheque or
postal order made payable to EMAP Books for £2.50 per copy (post free UK & Eire
only, others add 55p)

A practical guide to jobs from the makers of *Just Seventeen*

OUT NOW

ISBN No.1 8506 004 6

MOUNT CHALLENGE

The story so far:

48K SPECTRUM

Earth, 1987. A strange protrusion emerges from shark infested waters amidst a group of islands in the South Pacific. Nobody has yet reached this object, which is possessed by an evil force and guarded by deadly plants, murals, pigmen, chasing ghouls and yellow horned demons.

Prof. Burk arrives on the scene, resplendent in his newly invented space suit and jet pack able to withstand the forces emanating from the green and red blocks which cover the Mount. He intends to be first to the summit.

Woefully the jet pack cannot withstand all of the effects of the coloured blocks and therefore great care has to be taken when jumping from block to block, so as to ensure correct co-ordination of the ENERGY LEVEL (On/Off) with the coloured block being stood on.

Ignoring all advice against attempting his objective, the fearless mountaineer states, "people risked their lives to conquer Mount Everest, why not this challenge?"

Your mission is to help guide the determined Prof. Burk to the top of Mount Challenge (you'll need to draw a rough map as you go along). Good luck!

Extra info:

100% Machine Code

89 Screens

Keyboard OR
Kempston Joystick

Available from:

Aasvoguelle Productions (B),
Blakemoor,
Marshbrook,
Nr. Church Stretton,
Shropshire SY6 6QA.
Tel: (069 46) 345

Cheques/P.O.'s for £6.95

PS: The first 1,000 tapes sold will receive a FREE GAME on the B-side. Written by the same author. Take on three aliens at dominoes and try and get to the final of 'Point-a-Spot'.

WE'RE SERIOUS ABOUT GAMES

At the **VIRGIN GAMES CENTRES**, we've worked long and hard to put together the **UK'S BIGGEST RANGE** of **COMPUTER SOFTWARE GAMES**. We've got an unrivalled selection of... Arcade Games, Adventure Games, War Games, Classic Games, Family Games, Sports Games, Business and Educational Software. For Spectrum, QL, Atari, BBC, Electron, Commodore 64, Commodore C16, Enterprise, MSX and Amstrad machines.

Plus a large stock of utilities, peripherals, chess computers, books and magazines — and a range of Sinclair, Commodore and Amstrad hardware. **And if you find choosing software hard, we have a team of knowledgeable staff to help you.**

GAMES CENTRE

172 Union Street, Aberdeen • 94/96 Briggate, Leeds • 22 Oxford Street, London W1

A Tony Crowther/Quicksilva Production

GRYPHON



Actual screen shots

Available exclusively from

QUICKSILVA

in association with The Wizard Development Company Ltd.

COMMODORE 64 • Disk £12.95 •
Cassette £7.95



Quicksilva Mail Order,

P.O. Box 6, Wimborne, Dorset BA21 7PY. Telephone (0202) 891744.

THE SMASH HIT COMPUTER GAMES PACK



SPECTRUM 48K

TAPE A

3D STARSTRIKE (Realtime Software)
BLUE THUNDER (Elite)
SON OF BLAGGER (Alligata)
AUTOMANIA (Mikro Gen)
BUGA-BOO (Quicksilva)

TAPE B

PSYTRON (Beyond)
WHEELIE (Microsphere)
FALL GUY (Elite)
BLADE ALLEY (P.S.S.)
PENETRATOR (Melbourne House)



COMMODORE 64

TAPE A

TALES OF THE
ARABIAN NIGHTS (Interceptor Micros)
POSTER PASTER (Taskset Ltd.)
FLIGHT PATH 737 (Anirog)
PSYTRON (Beyond)
SON OF BLAGGER (Alligata)

TAPE B

SUPER PIPELINE (Taskset Ltd.)
TROLLIE WALLIE (Interceptor Micros)
AUTOMANIA (Mikro Gen)
GHOULS (Micropower)
BOOGA-BOO (Quicksilva)

AVAILABLE AT:

W H SMITH BOOTS MENZIES F W WOOLWORTH GREENS RUMBELOWS LASKY'S CURRY'S H.M.V. ASDA TESCO
GRANADA CO-OP TIGER DEALERS AND ALL GOOD COMPUTER SHOPS

GET YOUR HANDS ON A...



AND YOUR FINGERS WILL NEVER STOP FIRING!

Firing in all directions because *Fistful of Fun* is the latest compilation special from Alligata that brings together the action-packed excitement of 'shoot up' spectaculars with the nerve jangling demands of platform classics. Only Alligata compiles so many hit titles in one bargain buy that's sure to prove a hit with all the family.

TAPE
£9.95

Alligata Software Ltd.,
1 Orange Street,
Sheffield S1 4DW
Tel: (0742) 755796



DISK
£11.95

Send for full colour product brochure
(enclose a stamp)

BLOCKBUSTERS

BLOCKBUSTERS



MACSEN
SOFTWARE

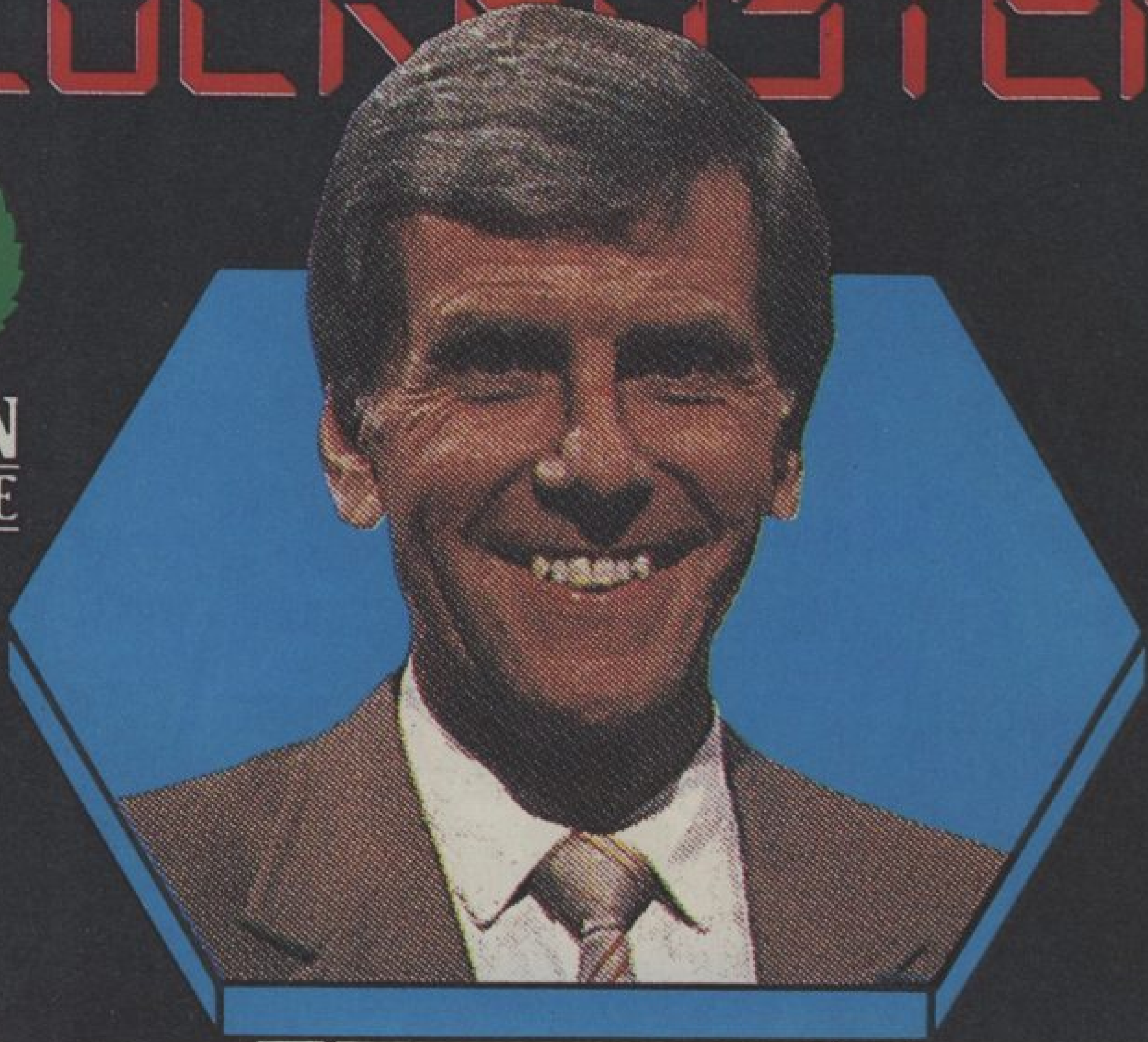

ER
E R
O V
K
O
S

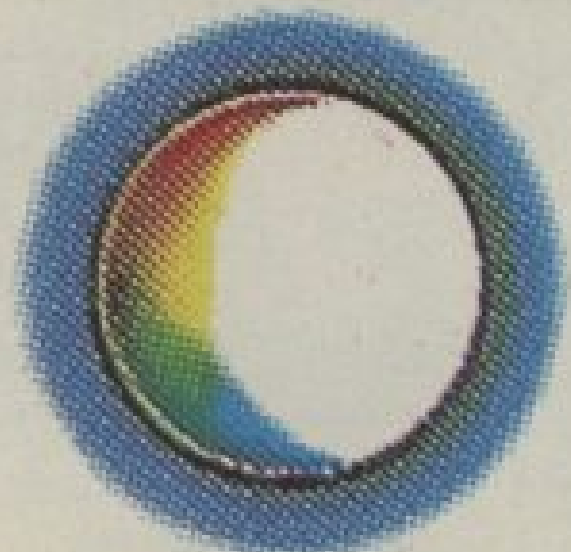

CENTRAL

SPECTRUM
48K

"Did you bring it?" I asked anxiously, "Have you got it, you know — the THING?"

"Sure," said Scott. "Well, sort of!" He grinned and pointed me in the direction of an IBM PC.



And suddenly there I was, in the shape of Ben Grimm, alias the Thing, stuck in a tar-pit and slowly sinking! I was in at the deep-end, or would be within a few moves, I guessed. So I transferred my ego to the Human Torch, for already I was aflame with an idea.



"This will impress the Chief Examiner," thought I! You've probably guessed what I was "THINKING" (Ugh!), but I don't believe it impressed the CE one little bit.

It certainly didn't impress the tar-pit which continued slowly to engulf the poor old Thing.

Scott had not finished writing *Questprobe 3*, based on the *Fantastic Four*, but I am sure that there was a way out of the tar pit from the fiendish look on his face!

"I don't quite know how much he's written yet," said Mike Woodroffe, head of Adventure International, behind his hand so that Scott wouldn't hear, "but when I tried it, it looked like only two locations." I knew exactly what Mike meant, but then *Return to Pirate's Island* looked like only one location for ages when I played it — but it was complete!

I had to leave the Thing to languish in the pit for a while. I will be back to tell you if (but not how!) I managed to release him within the next couple of months — just as soon as the Adventure is finished.

A meeting with Scott is always a good opportunity to ask a few questions on behalf of some of the many people who write in to the *C&VG* Adventure Helpline.



Scott's advice to Dwayne Carnadam of New Zealand, who can't get hold of most of his games, is to try Commodore International, or, failing that, Adventure International UK, at

85 New Summer Street, Birmingham B19 3TE.

Savage Island Part 1 is still defeating many players, including Steve Donoghue. In fact it still bothers me a bit! Having completed the game once, I cannot seem to repeat getting through the hurricane! There is obviously a random element in *Hurricane Alexis* — the time it starts, how long before the logs fall, and so on.

"To survive the hurricane, you must get that log as soon as you possibly can," said Scott. "The sooner you get it, the better the chances of being able to complete the tasks you need to do before Hurricane Alexis reaches its peak. It is possible that on some occasions you may not be able to survive long enough and will die, but those occasions will be very rare."

"Hyperventilate" is a word that has troubled some of our sneakier readers who have been peeking the text in *Claymorgue Castle*. "Perhaps you could ask Scott why he included this most obscure command?" asked John English of Northfield, Birmingham. So I did! "Hyperventilate" is the concise expression for breathing in and out deeply to absorb oxygen," explained Scott. "But, of course, there are other more obvious commands in the game that will achieve the same result!" he added.

Another obscure word, this time used in open text in *Return to Pirate's Island*, is "Funori". Scott laughed when I described my attempts to sail the ship there. "It's all in the *Encyclopaedia Britannica*. All you have to do is look it up!" he exclaimed. I said that's just what I had done, event-

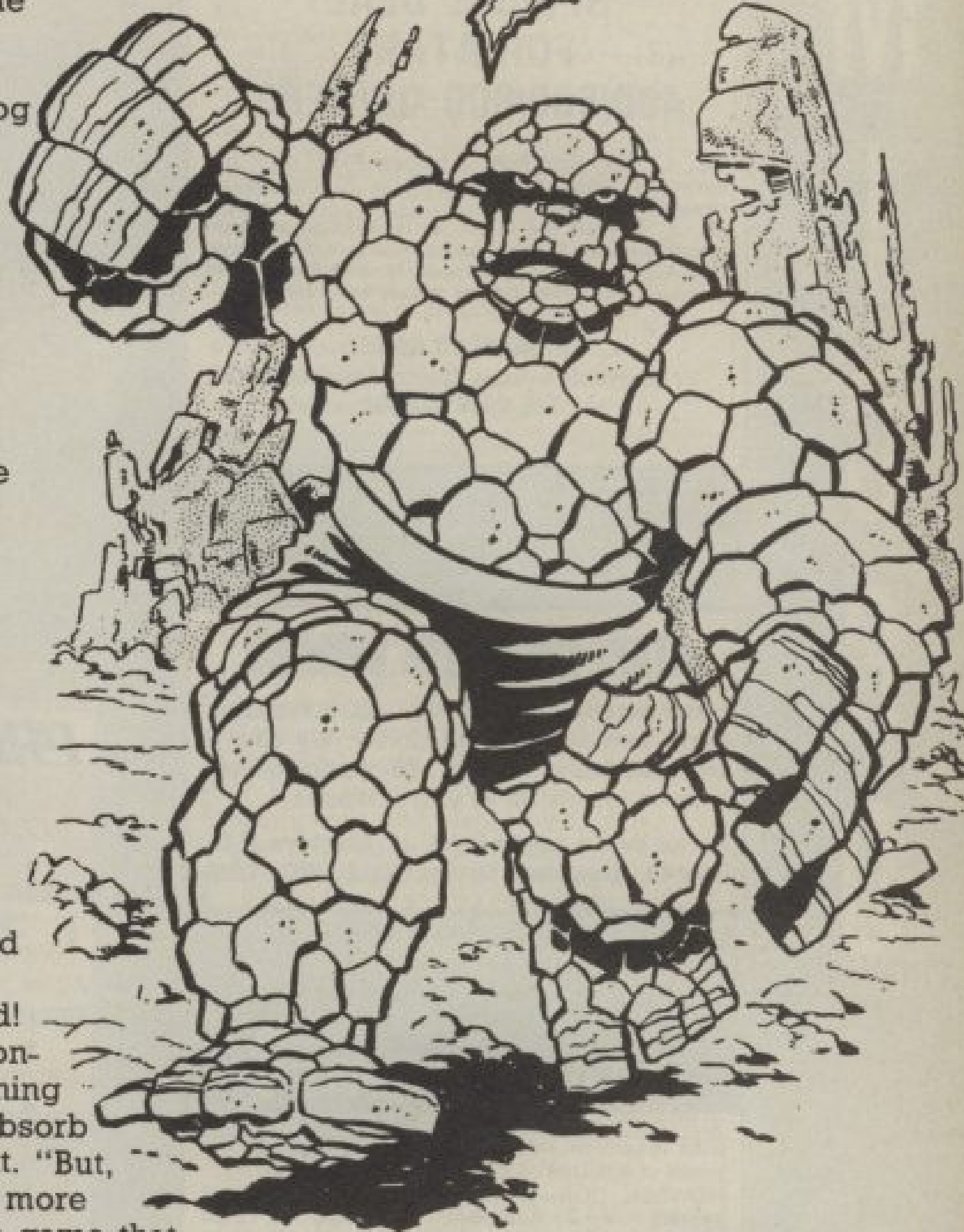

ually, to get on the right track. "In that case, I'll have to change my reference source from now on, to fool you!" he joked.

As I departed to catch the last train home, I left Mike Woodroffe explaining to a horrified Scott what wheel-clamps are and how they can get attached even to hire-cars that are parked in the wrong place!

Want to get your hands on one of the first copies of Scott's new *Questprobe Adventure*? We've got 20 copies of the game to give away thanks to Scott and Adventure International — all you have to do is answer the questions below, fill in the coupon and get it to us before June 15th — that's when the game will be released.

THE QUESTIONS

1. Name the four original members of the *Fantastic Four*. We've already given you a big clue — but beware!
2. Which *Marvel* superheroes featured in *Scott Adams Adventures* have starred in their

- own TV series? NOT cartoons!
3. Name two *Marvel* comics super-villains!

C&VG FANTASTIC FOUR COMPETITION

Name.....

Address.....

Computer you own (tick box)
Commodore 64 Spectrum
BBC

My answers are:

- 1.....
- 2.....
- 3.....

VIC 20/CBM 64 SOFTWARE HIRE

Free membership, top titles from 50p per week. Two first class stamps for your hirekit to VSH(CV), 242 Ransom Road, Mapperley, Nottingham. Please state which machine.

SPECIAL DEAL FOR ATARI 400/600/800 OWNERS

No. 1. Hire your first 2 games FREE from our extensive range of software. Up to the minute releases available.
No. 2. Buy all the latest software titles at best possible prices (New releases available direct from US) Atari hardware and modems now available at discount prices. For further details send s.a.e. to:

CHARWOOD GAMES
27 Warwick Avenue, Quorn, Leicestershire
Tel: 0509 412604

ATARI COMPUTER OWNERS

Make the most of your Atari 400/600/800 by hiring from our Software Library. We offer a wide selection of the many games and adventures on the market for your computer.

For full details send a S.A.E. to: **Star Hire, P.O. Box 48, Bracknell, Berks. RG12 4WD. CG69**

ATARI UTILITIES

AUTOMENU—Automatically lists every file on disc (Basic or binary) and will run them at the press of a button — £12.95.

HOWSEN DOS—A new disc file management system — 7 functions inc. tape to disc (single/double), disc to tape, disc to disc, tape to tape — £19.95.

DISK DOKTOR—With this utility you can examine and alter the contents of any Atari disk — £19.95

TAPE INSPECTOR—With this utility you can examine and alter the contents of any Atari tape — £12.95.

Also KT4—£9.95; DD2—£15.95; KK—£24.95.

For full details of this range of tape/disc/cartridge utilities send large sae to:

AWG
145 Bankside, West Houghton,
Bolton, Lancs

ATARI 400/600/800 XL SOFTWARE

We have an all round selection of disks, cassettes and cartridges FOR HIRE. Apply now and hire your first 4 games free. Well over 800 different original titles. For full details send stamped addressed envelope or telephone evenings 7pm - 10pm or weekends.

LOW ATARI PRICES

1050 DISC DRIVES £192.95
Purchasers of the above receive free membership

BEST QUALITY DISCS, BOXES OF 10
Single density discs £16.50
Double density discs £18.00
Antic & Analog magazines available

GAMES & SOFTWARE CLUB
Dept C&VG, 35 Tilbury Road, Thorney Close
Sunderland SR3 4PD. Tel: 0783 286351

FAST COMPUTER REPAIRS

VIDEO VAULT INTERNATIONAL 10★ REPAIR SERVICE

Spectrums repaired for £19.95 inc. Parts, Insurance and P & P No Hidden Extras.
BBC, Commodore 64, Vic 20, Atari. Quoted for.

Are you fed up with waiting weeks for your Home Computer to be repaired!!! Why not try the Experts, we offer a full repair service on any Home Computer. All repairs carry a full 3 months guarantee, plus on every Spectrum repaired we send you a free game worth £5.95 for your enjoyment and pleasure.

- ★ While you wait Service by Professional Computer Engineers.
- ★ 3 Months written guarantee on all repairs.
- ★ International repair company.
- ★ All computers sent by mail order turned around in 24 hrs.
- ★ Most Spectrums repaired within 45 minutes.
- ★ All Micros insured for return journey.
- ★ Open 7 days a week.
- ★ School repairs undertaken-discounts available.
- ★ Free software with each Spectrum repaired worth £5.95.
- ★ Over 8 years experience working with computers.

ONLY GENUINE SINCLAIR PARTS USED.

Phone today for your free estimate or send your computer to us with £1.75 (UK EIRE I.O.M. C.I.) or £6.50 (Europe/Scandinavia) we will contact you the same day by phone or 1st class Mail should you require quotation first.

TRADE ENQUIRIES MOST WELCOME. ACCESS WELCOMED
VIDEO VAULT LTD DEPT R10 THE LOGICAL CHOICE

VideoVault
VideoVault

Telephone: Glossop (STD 04574) 66555.
140 High St. West, Glossop, Derbyshire, England.

FREE GAME WORTH
£5.95 WITH
EACH SPECTRUM
REPAIR.

PAGE 6 THE MAGAZINE
FOR ALL ATARI COMPUTER OWNERS

NEWS
REVIEWS
TUTORIALS
UTILITIES
HINTS & TIPS
plus more

THE BEST PROGRAM LISTINGS from:
U.S.A.
U.K.
AUSTRALIA
PUBLIC DOMAIN SOFTWARE LIBRARY
SPECIAL OFFERS

PAGE 6 is published bi-monthly.
Annual Subscription is £7.00. Send TODAY to:
PAGE 6, P.O. BOX 54, STAFFORD, ST16 1DR
Tel. 0785 41153

REPAIRS

For all computers + T.V. games.
Good rates. Insured delivery.
Fast turnaround.
Trust the people who know.
Parts replacement despatch.

MERLIN GAMES
111 DOVER RD., DEAL, KENT.
Telephone: 0304-361541.

CARTRIDGE CITY
Simply the best cartridge rental service for Atari Computers.

Full information pack from
CARTRIDGE CITY
25 Gaitside Drive,
Aberdeen, AB1 7BH.
Tel. (0224) 37348

EXPRESS JOYSTICK REPAIRS

Joysticks repaired and returned within 24 hours, e.g. Atari, Vic, Quickshot, Triga Command etc. Send joystick and £2.95 + 50p.

ATARI/COMMODORE SPARES
Strong replacement joystick handle inserts at £2.50 pair. Atari £2.75 pair Commodore.
Joystick handle top fire button kit, includes insert and grip at £2.95 each Atari or Commodore.

JOYSTICK FOR QL
Plugs straight into control port 1 or 2. No interface required. £7.99 each or two for £15. Add 50p p&p.

BULK JOYSTICK PURCHASE
Shop soiled, as new. £14.95 for 5, £24.95 for 10 inclusive!

COMPUTER SUPPLIES, 146 CHURCH ROAD BOSTON, Lincs PE21 0JX

THE SOFTWARE LENDING AND EXCHANGE LIBRARY

SPECTRUM, COMMODORE 64, DRAGON, VIC 20, BBC & ZX-81

YES! We have programs for your computer. We hire programs from 50p. (ZX-81). Two weeks. £5.00 LIFE MEMBERSHIP (Less than the cost of a single game) brings you our membership kit, including hire listings, software exchange catalogue and introductory letter.

We now have OVER 300 HIRE TITLES, and 500 EXCHANGE TITLES, with large Spectrum and Commodore sections.

All mail dealt with on a daily basis and OVERSEAS MEMBERS VERY WELCOME. New software discounted to our members at impressive rates.

Send cheque/PO for £5.00 to:
THE SOFTWARE LENDING LIBRARY,
PO Box 3, CASTLEFORD,
WEST YORKSHIRE WF10 1UX

Stating name, address and computer type.
FORGET THE REST AND JOIN THE BEST!

ARCADE SOFTWARE (UK)

No. 1 Mail Order in UK

For Commodore 16 and 16+4; Commodore 64; Spectrum; MSX; BBC 'B' Electron; Amstrad; Dragon; Tandy; Vic 20; Atari 2600 Cartidges.

Prices start from £1.99
Fast service

Over 6,000 titles in stock
Send large stamped addressed envelope (please state micro).

Arcade Software (UK)
202/203 Shopping Hall
Myrtle Road, East Ham
London E6. Tel: 01-471 8900.

**FUZE
FUZED
DEFUZED
CONFUZED**
CONFUZION

**FOR SALE
SHARP
EQUIPMENT**

eg: *Inc. VAT - Exc. P&P*
MZ-80A.....£230
Twin Drives.....£345
P5/P6 printer (711 compatible).....£207
MZ80B.....£420
Also - interfaces, cables, single drives, expansion boxes, MZ-711 full systems to your requirements.
PERSONAL COMPUTER SERVICES
(Sharp approved Service Agent)
Unit 14, Alpha Court, Windmill Ind.
Estate, Denton, M34 3RB
Tel: 061 320 5011

**ATARI 400/600/800XL
OWNERS UTILITIES**

BACK-UPS
Tapes or Disks. SAE for Lists.
CRACKER
Will list M/C progs to screen, you edit, download your personalised version with or without m/c knowledge. Hours of fun changing text to leave personal messages on screen. Stuck on an adventure search for clues. Also acts to back up your Atari tapes.
All for only £10 on T.D.K. Tape (16K) Post Free
GHOST BUSTERS
By Activision. Seen the film? Now play the game, just in on disk £15 Post Free
BINO
Moves binary files to auto boot tape or disk.
Comes on double sided disk at £10 Post Free
XL-FIXER
Will allow you to play games written for 400, 800 range on your XL-tape £6
Disk version £10
PICTURE DISKS
4 Disks crammed with graphics, pictures and demo's to show the world Atari's No. 1 comes on two double sided disks at only £15
THE TRANS-PAC
Bought a disk-drive, stuck with programs on tape? **THE TRANS-PAC** solves it. Multi tape to disk, disk to tape, tape to disk, disk to disk, multi mover, etc. Comes on two double sided Memorex disks £25
All orders post free. Mail order only. 24 hour despatch.
STOCKSOFT
15 Woodbrooke Road, Birmingham B30 1UE

SPECTRUM SOFTWARE HIRE

FREE membership! All top titles available, for hire details send s.a.e. to: S.S.H. (CVG), 21 Chaceley Way, Wilford, Nottingham NG11 7EG.

NEW CONCEPTS IN SOFTWARE

BBC
Computer aided learning template system for teachers. Enables any teacher to quickly acquire a library of personalised teaching software. Price £25.00.
CBM64
Dr. John and the battle of the entropy; The Energy Race. Educational fun game for O and A Level/ Technician courses. Teaches fundamental concepts of engineering and heat. A revolutionary new approach to teaching with an emphasis on learning through play with full back up material. Price £9.95.
SPECTRUM
O and A Level Physics packages:
NEWTONS LAWS.....£6.95
WORK AND ENERGY.....£6.95
Super BASIC EDITOR. RESERVES space for code in REMs. FIND AND REPLACE everything, variable speed TRACE, DELETE blocks of BASIC, and much more.
Send to:
NEW CONCEPTS CVG
Rosenython, St. Keverne, Helston,
Cornwall TR12 6QR

**SECOND TI99/4A USERS
SHOW**

28th April 1985 11am-5pm

Corn Exchange, Royal Pavillion, Brighton. Extensive range of hardware, software and books. See the demo. Meet fellow users. Share in the swap shop and special show offers. Refreshments and meals available. Organised by the nationwide user group. **TI99/4A EXCHANGE, 40 BARRHILL, PATCHAM, BRIGHTON BN1 8UF. Tel: 0273 503968.**
SAE for details of advance admission and bumper quarterly magazine.

BLANK DISKS

5 1/4" Blank Disks - price per box of 10

Single Side/Double Density
SCOTCH 3M.....£14.95
DYSAN.....£17.95
MEMOREX (with free case).....£12.95
Double Side/Double Density
SCOTCH 3M.....£19.95
DYSAN.....£24.95
MEMOREX (with free case).....£16.95

SJB SUPER SAVERS

50 Memorex single side/double density blank disks in a perspex storage box only £64.95.

50 Memorex double side/double density blank disks in a perspex storage box only £79.95

All prices INCLUDE VAT. Delivery in UK is FREE. Please send cheque/PO to:

SJB DISK SUPPLIES,
Dept 01, 11 Oundle Road,
Nottingham NG8 1BN.



Tel: 0602 782310



ZOOMSOFT

FOR THE VERY BEST SPECTRUM, COMMODORE 64 AND ATARI GAMES (including U.S. SOFTWARE)

See page 105

**PERSONAL SOFTWARE
USERS ASSOCIATION**

Benefit from our huge library of cassettes for exchange or hire. More than 1000 titles for the Spectrum, CBM 64, Vic 20, BBC, Dragon, Atari, T.I., and Oric. Cheap hires and exchanges and special sale lines. For details send large SAE to P.S.U.A., 19 Lammerton Terrace, Dundee DD4 7BR stating which micro.

**ATOMIC STRUCTURE
A COMPUTER VIEW**

Award winning 48k Spectrum program illustrated. 13 important physics experiment with high-res graphics and text. Suitable for 'A' level. Price £5.50.

Send cheque/PO to:
NEW CONCEPTS SOFTWARE, C&VG,
ROSENTHON, ST. KEVERNE,
HELSTON, CORNWALL TR12 6QR

SOFTWARE EXCHANGE. Swap your used software, free membership, Spectrum/ Dragon, huge program base, see please to UK Software Exchange Club (CVG), 15 Tunwell Greave, Sheffield S5 9GB.

BEL-SOFT

Mail order software

All top titles at Low, Low prices. Just ring today for our list of special offers. All leading titles at least £1 off recommended retail. A chance you must not miss - ring today.

This month's special:

Everyone's a Wally, Spectrum £7.99
Knight Love, Spectrum £7.99
Impossible Mission, CBM 64 £7.99
Lords of Midnight, CBM 64 £7.99
Ghostbusters, Spectrum £7.99
Ghostbusters, CBM 64 £9.99

All subject to availability

For further details telephone:
(0743) 61493 (best after 6pm)

**ATARI HARDWARE
SJB SUPER SAVERS**

ATARI 800XL + ATARI 1050
DISK DRIVE £234.95
(includes home filing manager and pay off adv. and demo disks)
ATARI 800XL + ATARI 1010 RECORDER..£124.95
(includes Pole Position + Introduction to Programming cassettes)
ATARI 800XL COMPUTER.....£69.95
ATARI 1050 DISK DRIVE.....£17.95
All prices include VAT.
FREE, fast delivery in UK.
Send cheque/PO to:
SJB DISK SUPPLIES,
Dept 01, 11 Oundle Road, Nottingham
NG8 1BN.
Tel: 0602 782310



★ PANCOM

ATARI SOFTWARE ATARI SOFTWARE

• THE LATEST •
• THE BEST •

AT discounted prices
Send stamp for current catalogue

PANCOM
PO Box 49, Grimsby DN32 8QN
Tel: (0472) 694196

M
I
C
R
O

A
D
S

MYRDDIN



3D LANDMARKS YOU CAN FLY AROUND

SUPERB REAL TIME SIMULATION

MYRDDIN FLIGHT SIMULATION

AMSTRAD CPC 464



MANUAL

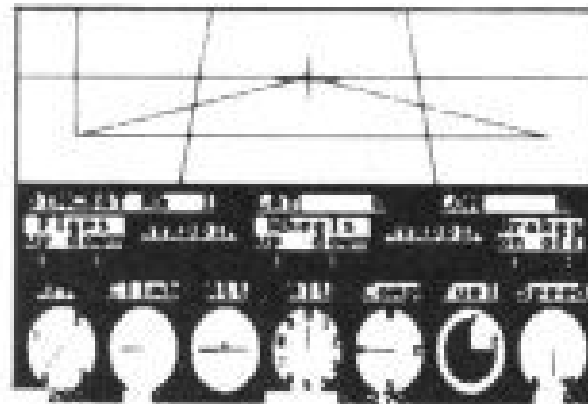

**FULL SCREEN
DISPLAY**

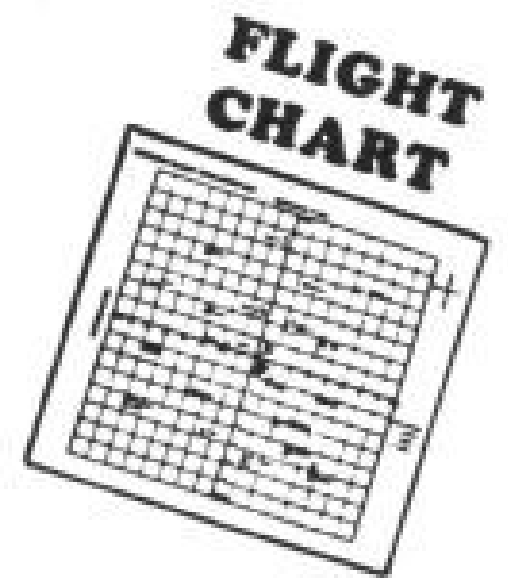

Here are some screens from a typical flight showing the view from the cockpit (top half of screen) produced as printouts of the actual simulator.

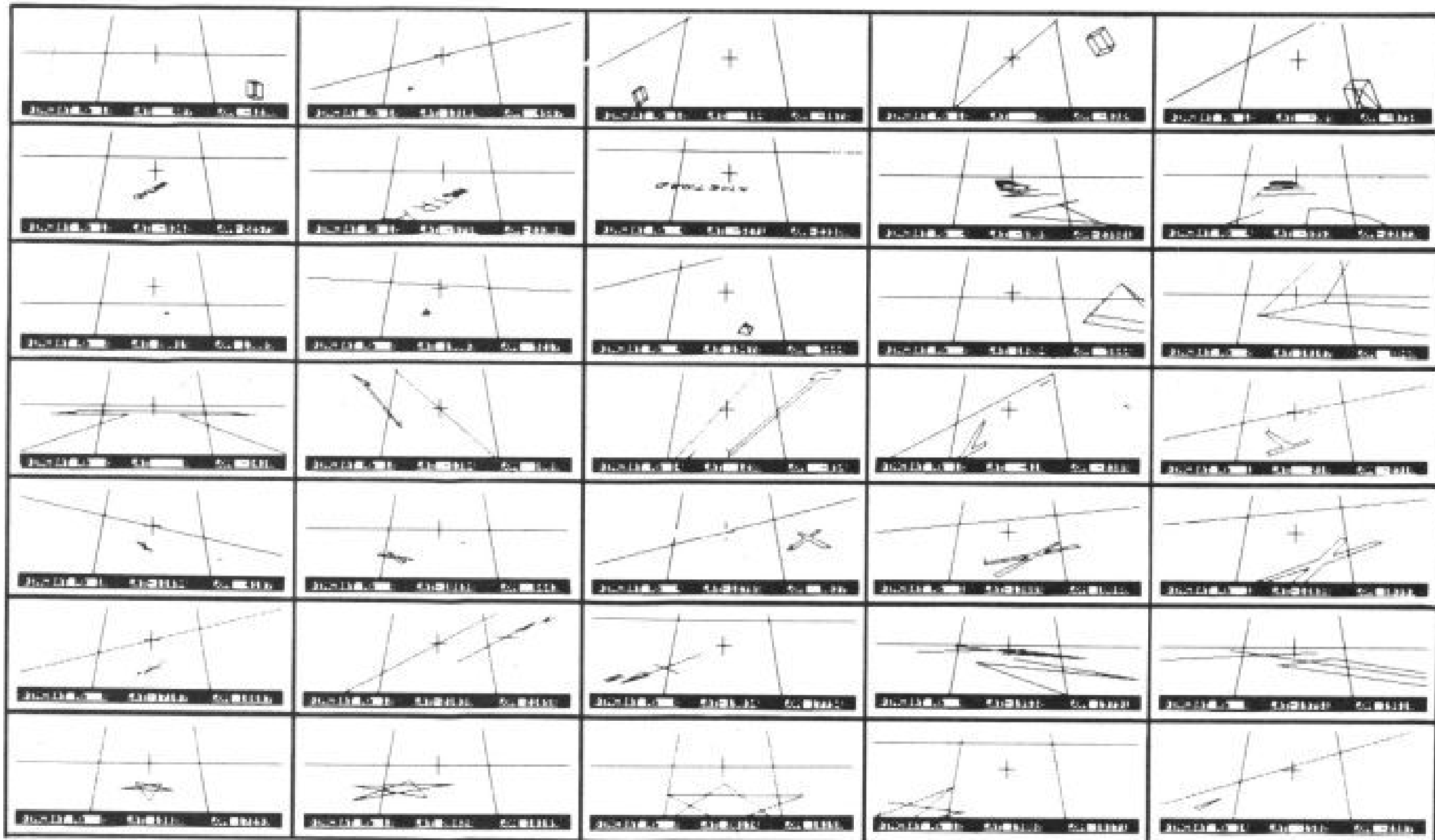

A real time simulation with 3D graphics uses a massive 64000 x 64000 longitude & latitude flying area, making each flight completely different. Developed under pilot instruction to give realistic flight effect. The view through the cockpit gives moving 3D graphics.

Comprehensive instrument panel with moving needle meters & digital displays. 15 aircraft types with varying control sensitivities & speeds of between 100 - 500 knots.

3 runways available for refuelling, take off & landing. Ground and landmark orientation correct with all flying attitudes (rolls etc.).

The 3D graphics are still accurate when you fly upside down.

3D landmarks you can fly around.

Comes complete with manual & fully detailed chart of landmarks & airfields.

Joystick or keyboard operation.

If your local dealer doesn't have it in stock yet, order from us direct. For despatch within 48 hrs. (usually 24 hrs.).



**MYRDDIN SOFTWARE, PO BOX 61, SWINDON, WILTS.
Telephone: (0793) 40661**

Please send me Flight Simulator(s) by return of post for the Amstrad CPC 464

Name

Address

..... Postcode

Cheque enclosed for £11.95 (in. P.P.)

OR Debit my Access A/C No.:-

□ □ □ □ □ □ □ □ □ □ □ □ □ □ □ □

OR Telephone through your Access Order.

Signed.....

AMSTRAVAGANZA!

**THE C&VG GUIDE
TO THE AMSTRAD**

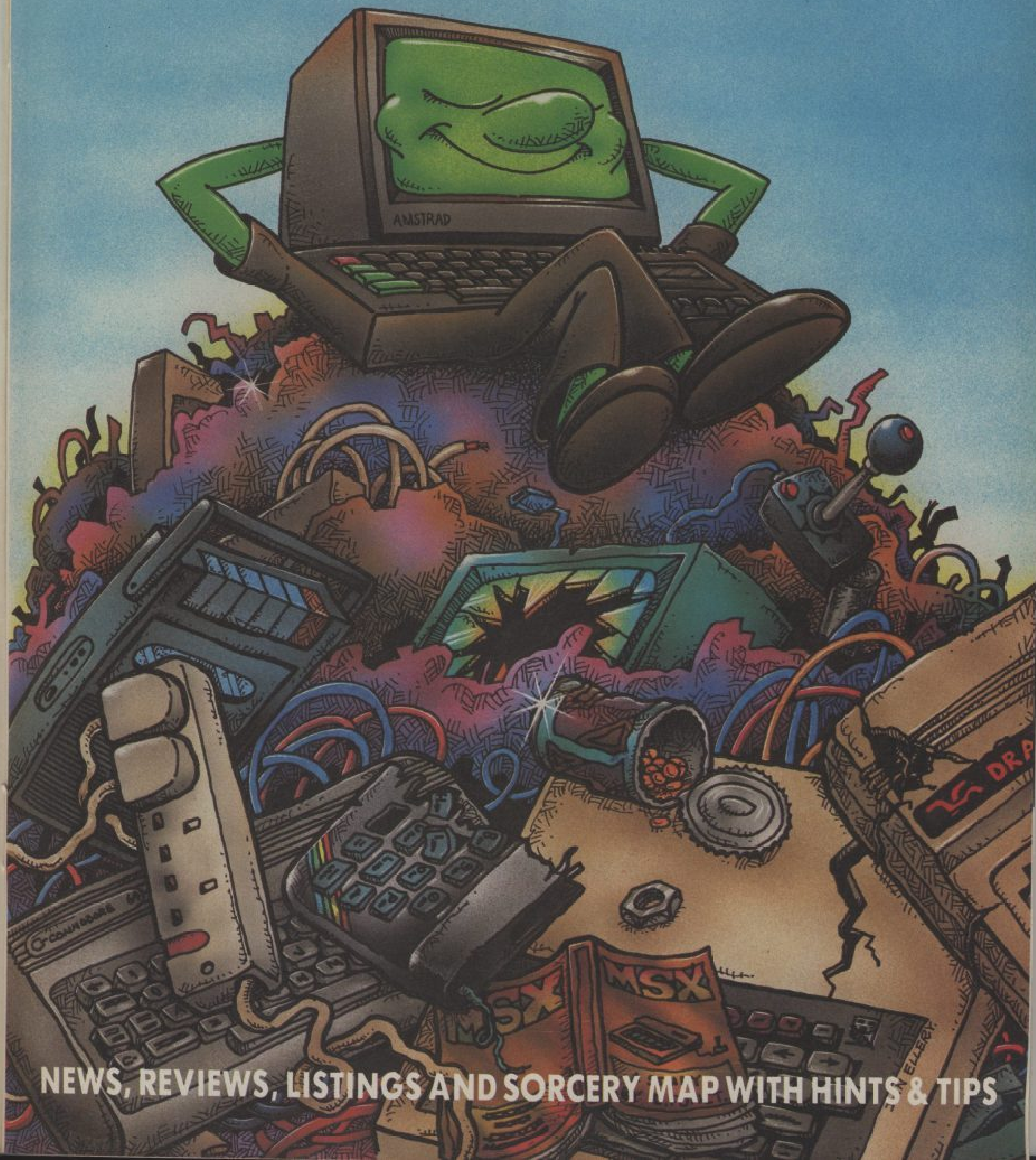

NEWS, REVIEWS, LISTINGS AND SORCERY MAP WITH HINTS & TIPS

SOLO



YOU ARE IN THE WOODS. 3



YOU ARE NEAR THE VILLAGE. 2



YOU ARE NEAR THE VILLAGE. 1



YOU ARE ABOVE THE CHATEAU. 7



YOU ARE ABOVE THE CHATEAU. 6



YOU ARE ABOVE THE CHATEAU. 5



YOU ARE IN THE CASTLE. 21

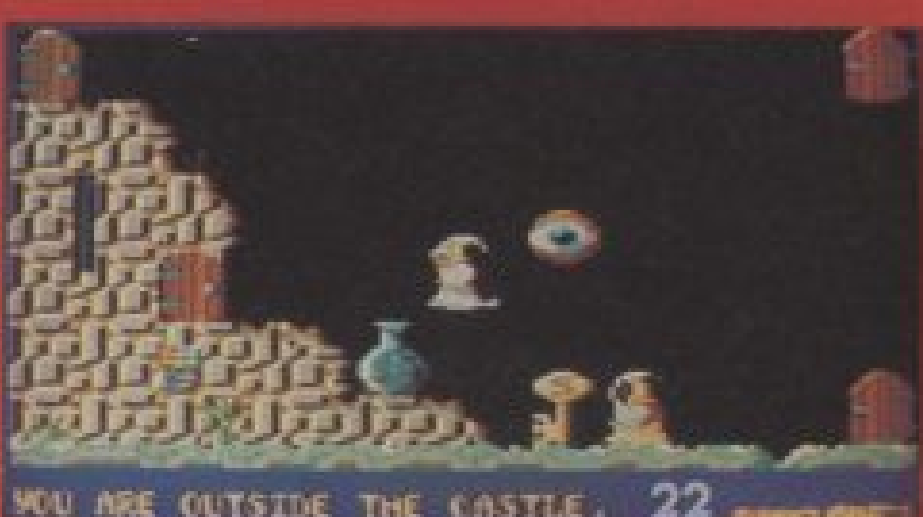

YOU ARE OUTSIDE THE CASTLE. 22



YOU ARE AT THE WATERFALL. 23



YOU ARE IN THE WASTELANDS. 39



YOU ARE IN THE WASTELANDS. 40



YOU ARE OUTSIDE THE CASTLE. 19



YOU ARE IN THE CHATEAU. 10



YOU ARE AT STONEHENGE. 36



YOU ARE NEAR STONEHENGE. 37



YOU ARE IN THE CASTLE. 20



YOU ARE IN THE WASTELANDS. 38



YOU ARE IN THE TUNNEL. 11

Sorcery

In Virgin's *Sorcery*, you play the part of a sorcerer set the task of releasing eight of his fellow sorcerers from imprisonment. There are 40 rooms to explore and, in addition to eight special objects you need to help you release the sorcerers, there are ten assorted weapons and aids to help you in your quest.



YOU ARE IN THE TUNNEL. 14



YOU ARE IN THE TUNNEL. 13



YOU ARE IN THE TUNNEL. 12



YOU ARE IN THE TUNNEL. 33



YOU ARE IN THE TUNNEL. 32



YOU ARE IN THE STRONGROOM. 16



YOU ARE IN THE PALACE. 26



YOU ARE AT THE WATERFALL. 25



YOU ARE AT THE TUNNEL MOUTH. 35



YOU ARE NEAR THE PALACE. 30



YOU ARE IN THE PALACE. 29



YOU ARE IN THE PALACE. 28



YOU ARE IN THE DUNGEONS. 17



YOU ARE IN THE CHATEAU. 9



YOU ARE IN THE CHATEAU. 8



YOU ARE IN THE PALACE. 27

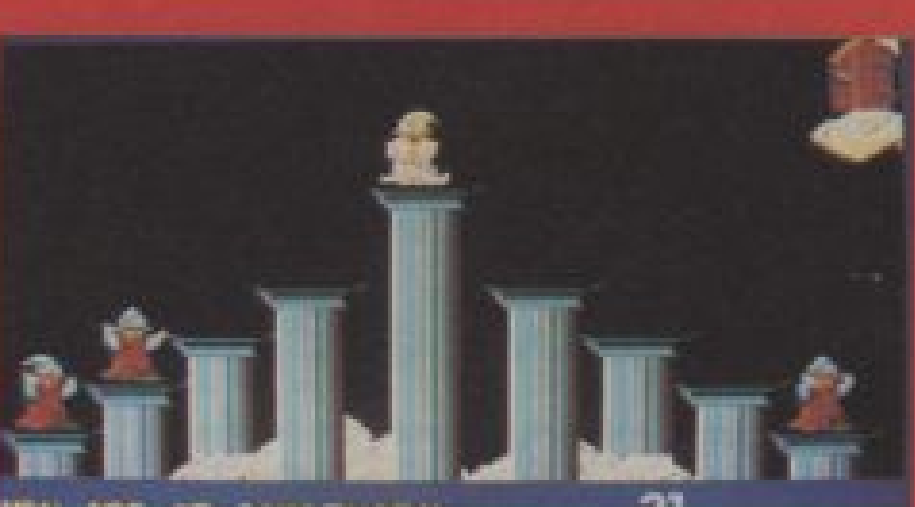

YOU ARE AT SANCTUARY. 31

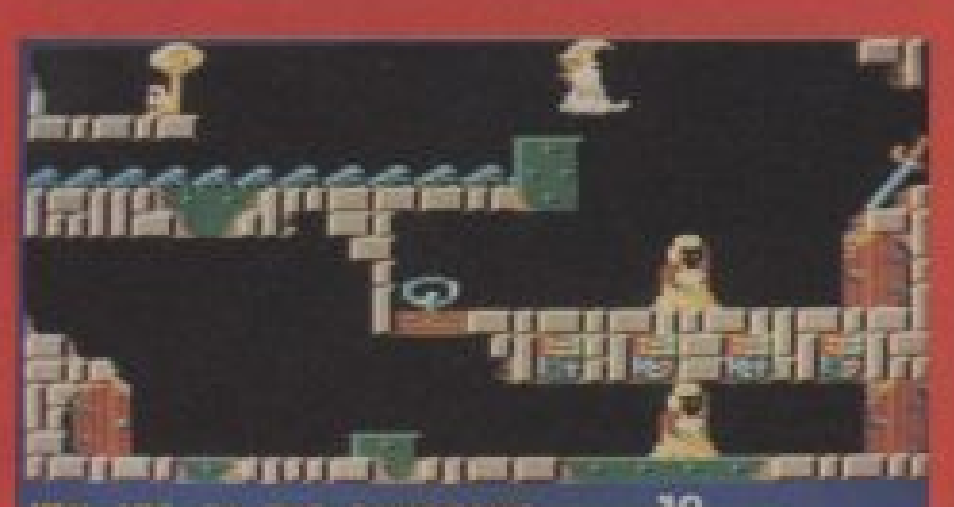

YOU ARE IN THE DUNGEONS. 18

ZAXXON FORT APOCALYPSE BEACH HEAD
 POLE POSITION CONGO BONGO
 SPITFIRE ACE SOLO FLIGHT
 UP 'N DOWN SPY HUNTER
 BRUCE LEE DROP ZONE
 BLUE MAX RAID OVER
 STELLA 7 MOSCOW
 PAC MAN FIS STRIKE
 SENTINEL EAGLE MR.
 FLAK NATO DO DREELBS
 COMMANDER KNIGHTS OF
 BUCK ROGERS THE DESERT
 INDIANA JONES CONAN SLINKY
 TAPPER FORBIDDEN FOREST DALLAS QUEST



GOLD STRIKE

**GUARANTEED PAYMENTS
 FOR FIRST CLASS ASSEMBLY LANGUAGE
 PROGRAMMERS**

Translation work on the chart-topping
 U.S. Gold Commodore games to the
Amstrad CPC 464.



Become part of the best motivated team in the U.K.
 . . . one-off or long term contracts available
 Original game and software concepts also required
 for World Wide publication.

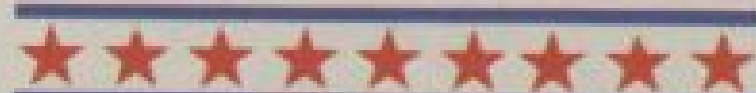

For fame and fortune from U.S. Gold
 write in confidence to:
 Software Development, U.S. Gold,
 6 Central Street, Manchester M2 5NS,
 or phone 061-832 6633 for details.

There are five types of deadly creatures, but each one can be killed by at least one or more of the weapons that can be found in parts of the game. It doesn't take long to find that a sack of spells or a shooting star will kill anything, but you must also find out which weapon kills which monsters because you can only carry one object at a time. The many other objects used in the game, including keys, bottles and fleur de lis, will enable you to enter locked rooms and open trap doors.

You will have to use almost all the magical objects to rescue all of the sorcerers and, with your energy level falling everytime you're attacked, you will have to move very quickly to survive.

For instance, in the Chateau, when you see the magic wand, you need a key to open the trap-door and a key to get the magic wand but there's only one key in the room. In order to get another key, you have to go out of the door on the top left. You will find yourself near the Chateau with two creatures, a key and a fleur de lis. To get back to the magic wand, you open the door with the fleur de lis. Once the door is open, you can go back again, pick up the key, return to the room containing the magic wand, release the trap door, pick up the spare key, release and pick up the wand and escape through the left hand door into the Tunnel. Now take the wand through the bottom left hand door. You will now be in the Tunnel with two creatures, a key, a river and an energy-giving cauldron but, unless you have a shooting star or a bag of spells, you can't kill both of the monsters. So, from here it is a desperate rush to free the sorcerer and escape as quickly as possible, leaving the Tunnel by the door you came in.

The easiest sorcerer to release is the one in a room above the Chateau, who is released by a book of spells found in the same room. You will find that this reveals another door which you cannot get through. If you leave this room by the top right hand door, you will find yourself in a room with a floating eye, a warrior, a sword and a bottle. The warrior can be killed with the sword if you like, but you must take the bottle with you on your way out.

You will now be near the Chateau again with two creatures and two objects — including the golden chalice — but to open the mystery door you must carry on towards the woods carrying the bottle. Use the bottle to open the door, kill both monsters with the shooting star, replenish your energy from the cauldron but, most importantly, pick up the fleur de lis. Retrace your steps to the mystery door and — Open Sesame! — this reveals another

sorcerer who can be released using the golden chalice seen two screens earlier.

Each sorcerer can only be released by using a certain object. For instance, you can use the Sorcerer's Moon to release your colleague at Stonehenge. A harp will free the sorcerer cooped up in the palace and a goblet of wine will do the trick for the sorcerer stuck out in the Wastelands. These are fairly straightforward cases of hunting down the object. The last two sorcerers, however, are linked together and prove very difficult to release.

When you are in the Castle you'll find a room with a scroll and a coat of arms. Bearing your coat of arms, leave the Castle by the right hand door and you will be able to open the door halfway down the cliff face. Once you've opened this door, return to the Castle and pick up the scroll. Returning via the cliff into the dungeons, use the scroll to release another sorcerer, making use of an axe in his cage to kill the monster in the room. You must leave by the left hand door, picking up a bottle as you go. This particular bottle is used to open a trap door, but first use a nearby sword to kill the warrior in the way. Pick up the key in the top left hand corner and use the bottom right

hand corner to enter the Strongroom. Open the trap-door with the key. It is a good idea to clear this room with a convenient sack of spells. To release the sorcerer, you must now go all the way back for the coat of arms in the Castle, then back through the Dungeon to the room where you picked up the key.

Go through the left-hand door into the Wastelands. This is where you will find the crown to release the final sorcerer, but you can't go from the Wastelands back to the Dungeon without first using the coat of arms to open the door. Once you've done this, simply take the crown into the Strongroom and release the sorcerer.

Whatever order you release the sorcerers in, when you have released all eight of them, don't forget to go back to The Sanctuary and join your fellow sorcerers on your pedestal.

You've then beaten the game!

In order to get higher scores, though, you must pick up as many objects, kill as many creatures and visit as many rooms as possible. Releasing all the sorcerers will win you the game but it won't necessarily get you the most points.

I hope I haven't given too much away — but there's lots more in *Sorcery* for you to discover yourself. Have fun!

SORCERY MAP FOR AMSTRAD CPC 464

SECTION 1

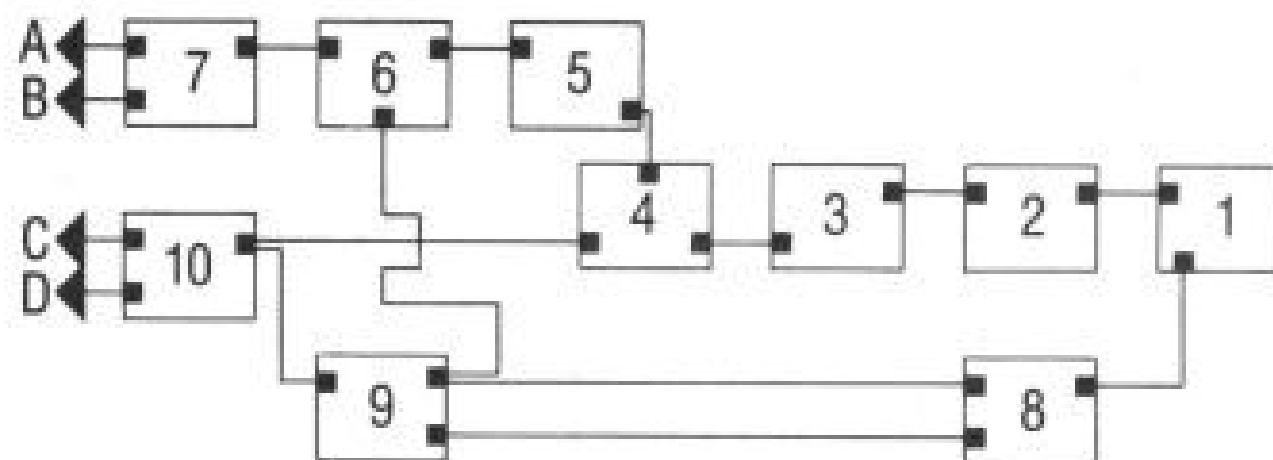

SECTION 2

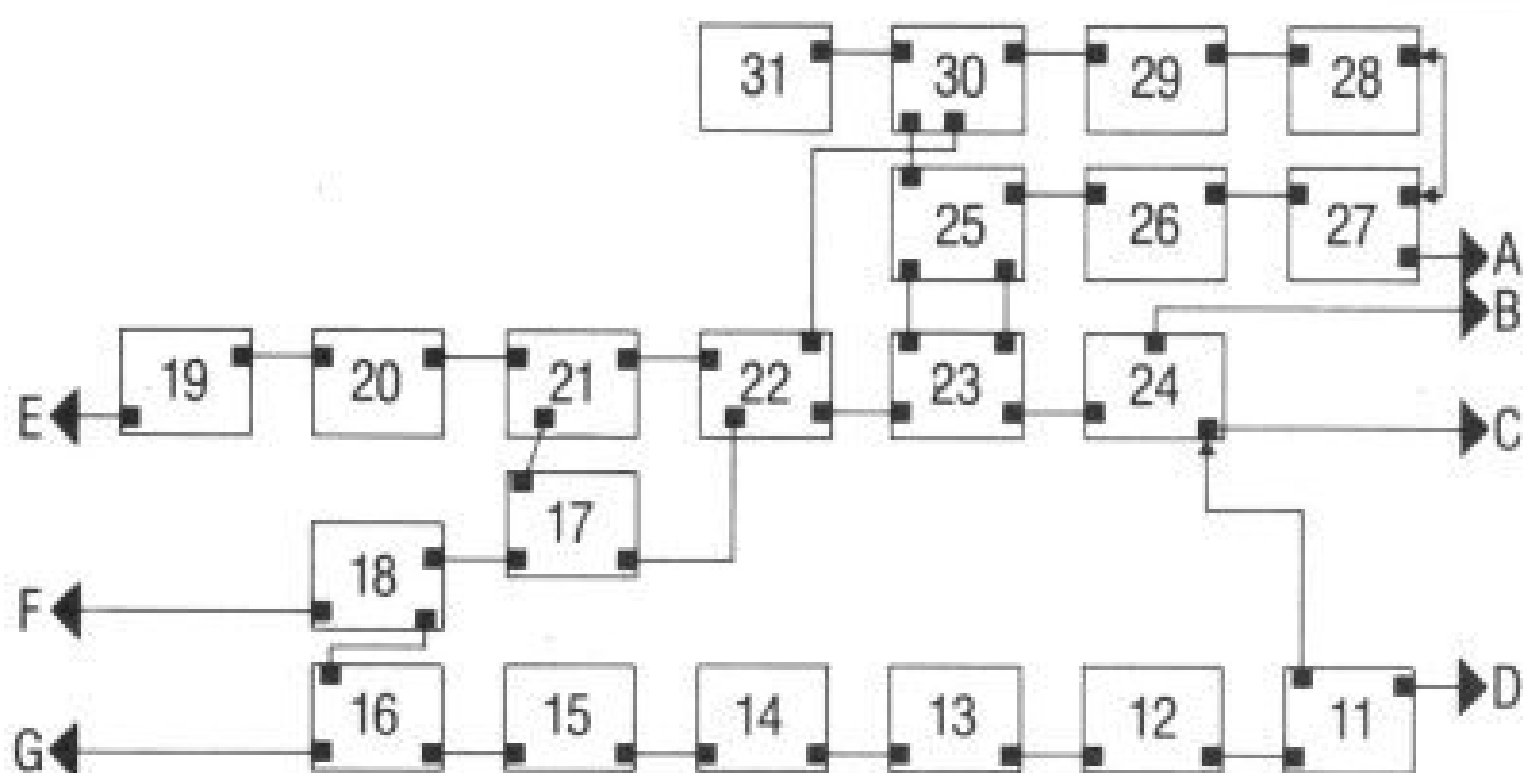

SECTION 3

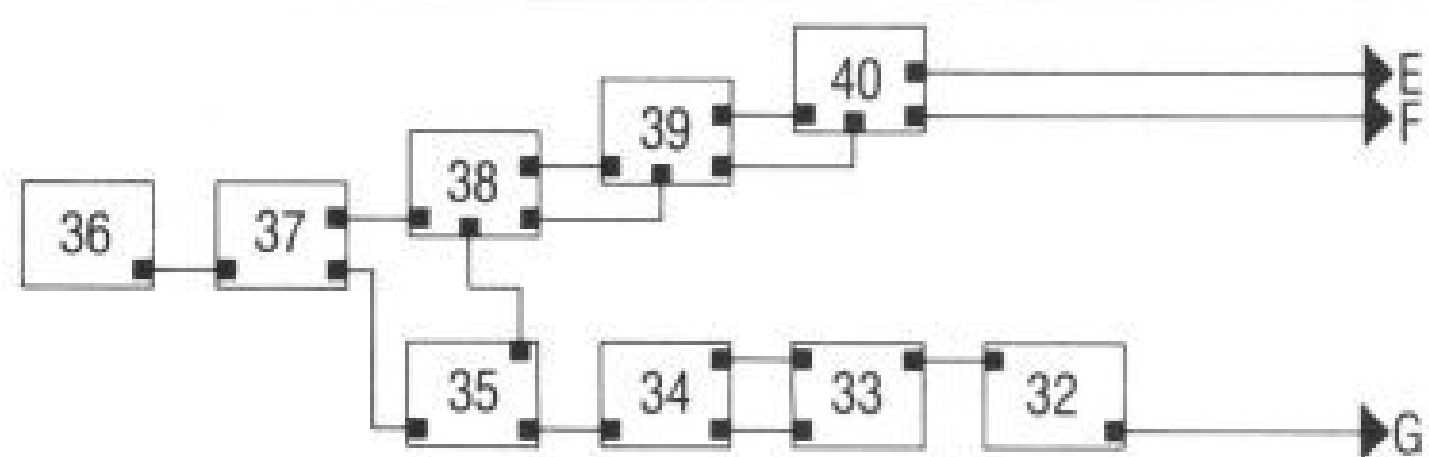

Make your own map of Virgin's Sorcery for the Amstrad CPC 464 out of actual screen shots. Just cut out the screens on pages 54 and 55 and paste them up in the layout above and give yourselves hours of endless fun.

AMSTRAD NEWS

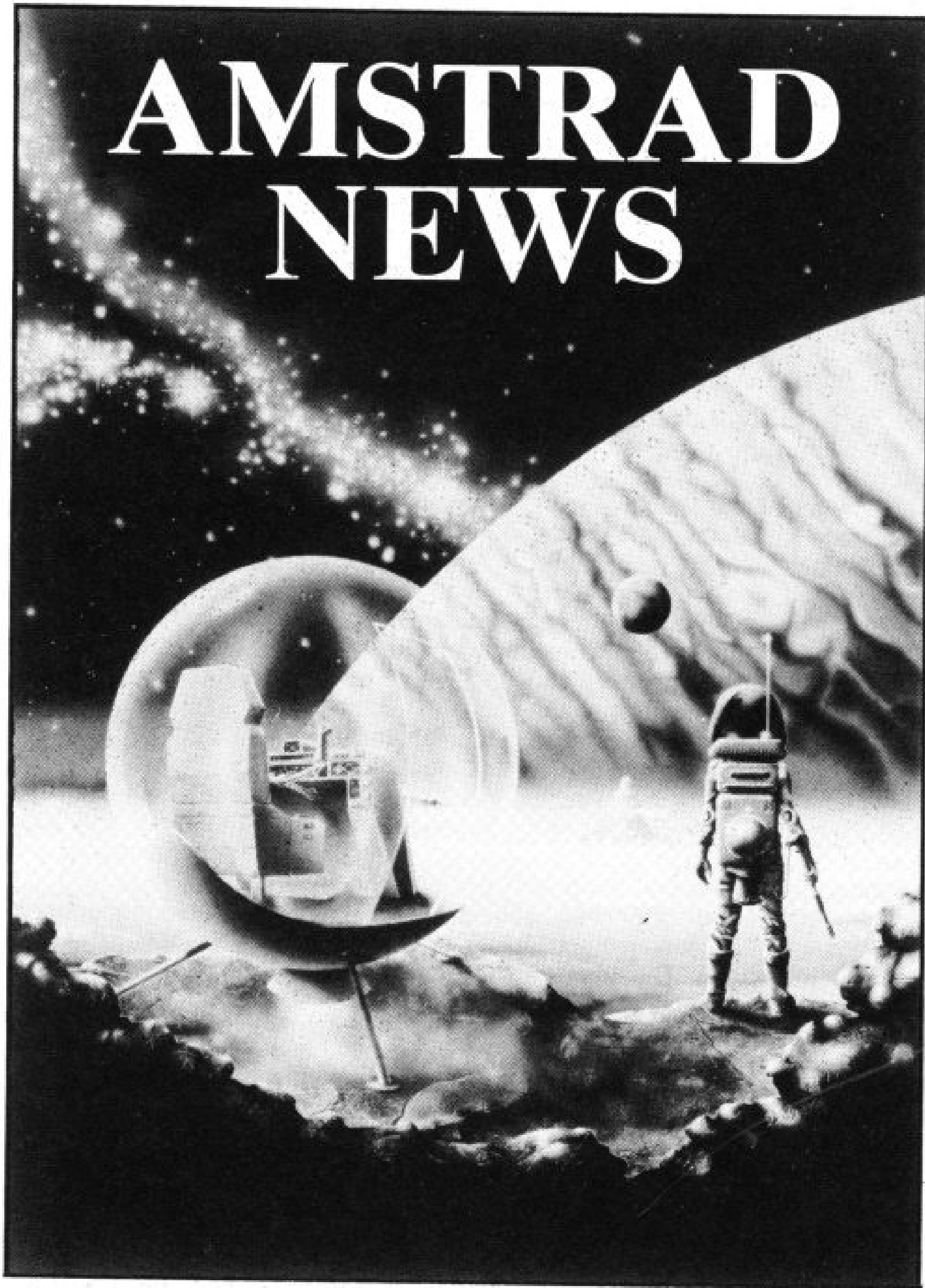

BACKPACKER'S GUIDE TO THE UNIVERSE

Fantasy Software's very successful trilogy of arcade Adventure games is to be converted to run on the Amstrad CPC 464 computer.

The Backpacker's Guide to the Universe, a series of three Adventure games featuring the character Ziggy who starred in Fantasy's other game *The Pyramid*, is loosely based on the hugely successful book and TV series *The Hitch Hiker's Guide to the Galaxy*.

The unique feature of the game is that it contains an information program at the end of the tape which gives you hints and advice on how to complete some of the puzzles in the game, similar to the Encyclopaedia Galactica in *Hitch Hiker's*.

The first program on the tape also contains a mini version of the guide but to access the whole of the second program you have to stop playing the game and load the second program — making sure that you don't have the chance to keep referring back to it.

The first part of the trilogy, entitled *The Caverns of Exile*, will be available in the next few weeks and should sell for around £7.00. ●

DECATHLON

Ocean Software's best selling trio of programs is being converted to run on the Amstrad.

Daley Thompson's Decathlon, *Hunchback II* and *Kong's Revenge* are all presently Ocean's top sellers at the moment and are riding high in the charts. *Daley* was probably the most successful game of last year apart from perhaps Software Project's *Jet Set Willy*.

Street Hawk a new series on Independent Television is also going to have a computer version on the Amstrad, Spectrum, Atari 800 and Commodore 64.

Ocean have purchased the full licensing rights to the game which will be on sale in mid-May.

The new TV programme is very like an old one called *Knight Rider*. The star is an electronic motorcycle equipped with an astonishing array of high-tech weapons which are used in the pursuit of criminals.

Ocean have also scooped up the rights to the popular series *Knight Rider* — a computerised car this time.

The game will be available on the same machines as *Street Hawk* and should be released in September.

All Ocean's titles for the Amstrad, including *Decathlon*, will sell for £8.95 each on cassette. ●

Frankenstein 2000 is a futuristic game based on the legend of the monster created by Doctor Frankenstein.

You are a renowned scientist of the 21st century who has been working on a project to develop revolutionary new surgery that allows bionic limbs to be added to even lifeless bodies.

Spurred on by the challenge of resurrecting Frankenstein's

FRANKENSTEIN

monster, you decide to use a new micro surgical technique in which you are shrunk down to a microscopic size together with a submarine-like capsule and then injected into the body of the patient.

You must fight off the attacks of the monster's defence systems on the way towards the brain to repair the damage that has been caused by his years in suspended animation.

Frankenstein 2000 will be available from Icon Software for £6.95. ●

PSS have launched one of their most successful war simulations, *Battle for Midway*, on the Amstrad CPC 464.

Battle for Midway puts you in command of the US Pacific fleet six months after the Japanese bombing raid on Pearl Harbour in 1942 which finally brought America into the second world war.

MIDWAY

The Battle of Midway marks the turning point of the battle for the Pacific. If the Japanese are allowed to invade the Midway Islands, they would have a base from which to attack firstly Hawaii and then mainland USA, possibly changing the whole outcome of World War II.

Battle for Midway is one of the new breed of wargames that actually place you in a life-like situation where you have to make decisions on when to attack or retreat and how many troops to send into each battle — so the buck stops with you!

The game is played on three levels. First, you are given a large scale map showing an overview of your own forces. Second, you have constantly updated details of those forces down to the last fighter. Third, you get a visual representation of the battle and your forces at every stage. This way you are kept well briefed on your exact position.

Battle for Midway is available for the Amstrad, MSX, Commodore 64 and Atari computers. ●



DALEY THOMPSON'S SPOT THE DIFFERENCE CONTEST

Daley Thompson's Decathlon, the smash hit game which sprinted its way to the top of the charts during last summer, is on the starting blocks and is almost ready for the Amstrad.

As always, *C&VG* are a step ahead of the competition and we have 50 advance copies of Ocean Software's *Daley Thompson's Decathlon* for the Amstrad to be won in our spot the difference competition.

Just check both of the pictures of Daley and try to spot the four differences in the illustration at the bottom. All you have to do then is fill in the missing items in the spaces on the coupon and send it off to *Computer & Video Games*, Priory Court, 30-32 Farringdon Lane, London EC1R 3AU.

Daley is a complete simulation of the two day Olympic event in which you must excel at ten different sports ranging from the pole vault to the 110 metres hurdles.

DALEY THOMPSON SPOT THE DIFFERENCE COMPETITION

The differences are: 1).....
 2).....
 3).....
 4).....

Name

Address.....



R·E·V·I·E·W·S

Playability: Will the game keep you up until the early hours of the morning, as you attempt to complete just one more screen in a desperate attempt to beat it? Or does it send you to sleep the moment the intro-screen appears? Could you spend hours locked away in your bedroom with it?

1 WORLD CUP

MACHINE: Amstrad
SUPPLIER: Artic Software
PRICE: £7.95

England's surprisingly good form in their recent world cup qualifying matches has created a resurgence in football support and even computer addicts, not known for their athletic prowess, are getting itchy feet and yearning for the sight of acres of muddy grass.

The Amstrad has its very own version called *World Cup* by Artic Computing which on first appearance looks very like Commodore's *International Soccer* cartridge.

The game begins by asking you to choose one of the 12 teams on offer, ranging from Brazil to Wales.

The game then goes through the preamble of having all the players trot onto the pitch in pairs and stand in their proper positions. After this performance, which lasts several minutes, the whistle is blown and your off.

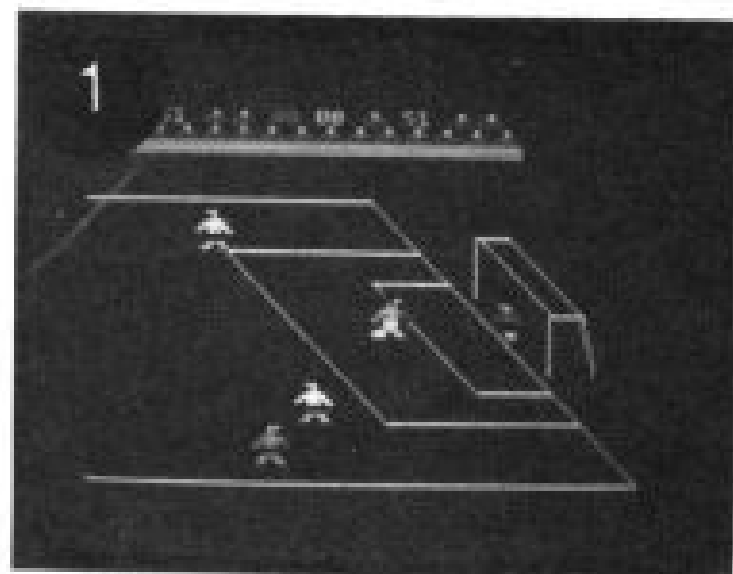

You then have a game lasting around 15 minutes which includes a change of ends at half time. At the beginning, the computer slaughters you every time. Wingers dash along the touch line, dancing past your defenders, dummy the keepers and smash the ball into the back of the net. Typical score lines are: 7:0, 8:0 and 12:1 — a lucky shot in the last game.

But once you have played the game several times, you notice that the computer players always behave the

same way in certain situations. Once you have learned these "programmed" moves, it becomes very easy to run rings around the computer controlled teams and I had soon won the World Cup four times on the trot with a little practice.

● Graphics	8
● Sound	5
● Value	6
● Playability	5

2 FIGHTER PILOT

MACHINE: Amstrad
SUPPLIER: Digital Integration
PRICE: £6.50

Fighter Pilot was the first true aeroplane flying simulation available on the market which was a truly realistic representation of flying a jet aircraft.

The man behind the game, designer and part owner of Digital Integration Dave Marshall, is a qualified pilot and has made every effort to make the program as life-like as possible.

Fighter Pilot is an incredibly complex program though. There are, for instance, 23 different keys that are used during a full game. The game is based on the McDonnell Douglas F15 Eagle fighter plane and includes air-to-air combat options in the program's menu.

At the beginning of the game you are given a list of different options ranging from take off and landing practice to airborne combat. There are also four levels of difficulty — sensibly I chose trainee level and the practice landing options.

Predictably, I crashed fairly rapidly on my first few attempts. Soon I was able to keep the plane under reasonable control but still hadn't mastered the art of landing in one piece. Either I was descending too quickly and hit the ground before I could get more thrust from

the engine or I came into land too fast and had my undercarriage ripped away from me.

Fighter Pilot is an incredibly complex program — to do it full justice this review would have to take up several pages of the magazine. It is, in my opinion, the game with the most playability and the longest lasting appeal I have played on the Amstrad.

This, of course, doesn't mean that I would recommend it to every Amstrad owner. If you like to get straight into a game hardly even needing to glance at the instructions, just pick up your joystick and start firing, then *Fighter Pilot* is not the game for you. On the other hand, if you are willing to spare quite a few hours getting to know the game, you will have guaranteed yourself months of flying fun.

● Graphics	8
● Sound	7
● Value	9
● Playability	9

3 ROLAND AHOY

MACHINE: Amstrad
SUPPLIER: Amsoft
PRICE: £7.90

Roland Ahoy is an addictive if not particularly sophisticated release from Amsoft. It is one of those games which you know you can beat quite easily but fail repeatedly to do so.

You play the part of Roland, a vicious and ruthless captain of a pirate ship, on the look-out for any unattended treasure that he can bury on some remote desert island.

Sailing across the ocean is never an easy job at the best of times but sea monsters and rocks don't make Roland's life any easier.

To get to the treasure, you must first help Roland steal cannon balls from the powder

quay. As soon as his ship docks at the quay, your ship is attacked with cannon fire and you must guide Roland through the mayhem to collect a box of cannon balls. Once you have loaded up the armaments, you can set sail for the Gold Harbour — the centre of trading for this part of the world and a town filled with prosperous merchants and business men.

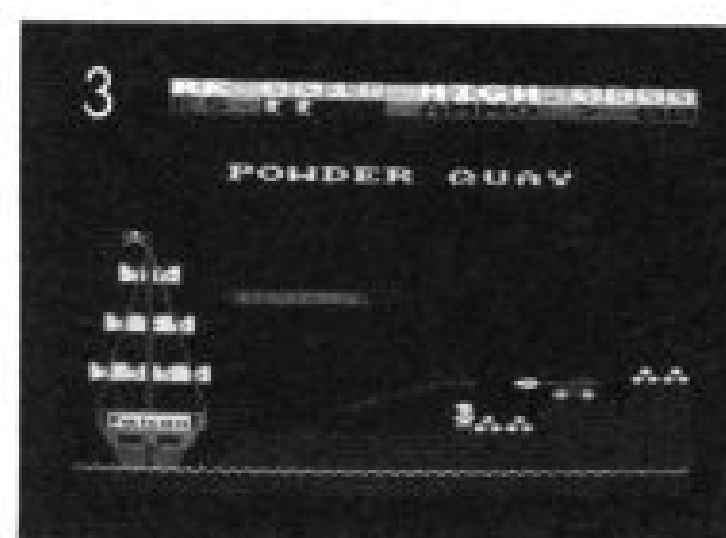

When you have tied your ship up in the harbour, you have to sneak into the town and steal as much treasure as you can carry. Not surprisingly, the town's inhabitants are less than happy about this arrangement and you have to run back to your ship dodging a hail of bullets. From here, you must travel to the nearest desert island to bury your treasure. And this is where *Roland Ahoy* and I parted company.

At the beginning of this review I said that the game had a certain addictiveness. The only reason the game has any addictive qualities is because you know that the game is dead easy to complete and all you want to do is just that to prove how bad the game is. Unfortunately, you can't even do this because *Roland Ahoy* has so many annoying features and unexpected bugs.

There is no skill in the game or enjoyment to be got from this piece of software. It is, in fact, an absolute dead loss!

● Graphics	6
● Sound	4
● Value	3
● Playability	4

GH**OST**BUSTERS™ THE COMPUTER GAME.

BY DAVID CRANE



© 1984 COLUMBIA PICTURES

NOW AVAILABLE ON AMSTRAD AND MSX!

STILL RUNNING ON COMMODORE C64 CASSETTE AND DISK, SPECTRUM AND ATARI DISK.

ACTIVISION
HOME COMPUTER SOFTWARE™

AVAILABLE FROM SELECTED BRANCHES OF BOOTS, WH SMITH, JOHN MENZIES, LASKY'S, SPECTRUM, RUMBELOWS, WOOLWORTH AND GOOD COMPUTER SOFTWARE STORES EVERYWHERE.



Graphics: Are they really as mind-blowing as the adverts say they are? Does the screen scroll effectively? Do those aliens really leap out of the screen at you? This is how this category is judged



4

4 BLAGGER

MACHINE: Amstrad
SUPPLIER: Alligata Software
PRICE: £7.95

Computer games fall into several different categories of programs, for instance, adventures, shoot'em-ups and strategy games all of which are very popular. A new game for the Amstrad, *Blogger*, is in the most popular category — the climbing games.

Blogger is one of the many games which has been spawned from the American game, *Miner 2049'er*, primarily *Manic Miner*, a game which *Blogger* resembles in many ways.

The basic theme of the game is roughly the same as MM. You have to guide your character through many dangerous and tricky caverns, collecting sets of keys that will open a door to the next level of the game.

Monsters and hunter killer robots patrol each of the levels making sure that no fortune seeker who enters their cavern emerges alive. Like MM, the monsters don't chase you, but move in a fixed route preventing you from making an easy escape.

The game does sound similar to *Manic Miner* and, for my taste at any rate, it is a little too close in some parts for it to be a mere coincidence. The crumbling platforms are straight out of *Manic Miner* as are the poison plants and some of the screen lay-outs.

This is, of course, fine if you don't already own a copy

of *Manic Miner*, but is a bit of a bummer if you do.

It's fast becoming repetitive the amount of times I have given the same advice to people interested in buying new software — buy it because it's a good game, but don't buy 20 other games because they are all exactly alike.

Blogger is a well written and professionally produced game. But I think it would be a shame to see it in the same software collection as *Manic Miner*. I mean — why waste your money when you could buy a copy of Virgin's *Sorcery*.

● Graphics	7
● Sound	6
● Value	7
● Playability	7

5 JAMMIN'

MACHINE: Amstrad
SUPPLIER: Taskset
PRICE: £8.90

Jammin' is anything but an ordinary game.

In the game, you play the part of "Rankin Rodney", a street musician who is trying to make it into the big time. Unfortunately for Rodney, he is having a lot of problems getting all his instruments together in the same place.

Bad notes and bum chords trouble Rodney and, if he happens to run into one, he drops everything at the shock of hearing such an awful noise.

The game is played on a multi-coloured maze which has part of the screen moving in four separate directions, like coloured escalators. Rodney must hop onto the coloured escalators and jump off at the right point to collect the particular musical instrument he wants which he then brings home.

Rodney has a couple of enemies who try to halt his progress. Bum notes travel all

across the maze. If Rodney happens to run into one while he is carrying a musical instrument, he instantly drops the instrument which returns to its original position in the maze.

To move on to the escalators, Rodney must wait for a coloured square of the same colour as the one he is standing on, then the joystick is pushed in the direction in which he wants to move.

The game has 20 different levels and should provide several weeks of hair-pulling sessions. Consider yourself an expert if you manage to finish the game without a receding hairline.

Jammin' is an unusual and very entertaining game. Well worth the pennies it costs, too.

● Graphics	8
● Sound	9
● Value	8
● Playability	9



6 CENTRE COURT

MACHINE: Amstrad
SUPPLIER: Amsoft
PRICE: £7.90

The only thing in Amsoft's *Centre Court* which has been left out is the odd tantrum from one of the players — but I suppose you could supply that yourself.

Centre Court is a simulation of the lawn tennis game and includes options for either a two player game or a single person against a computer opponent.

Not only is the grass court represented on the screen,

there is also a cheering crowd, an umpire and line judges which are all animated beautifully. The representation of the players and the ball — which is just too small — is a little disappointing. Otherwise the game is comparable with the best tennis simulations on other machines and is more reliant on skill than most in not letting the computer do most of the work for you.

Serving is made much more difficult than in most other games because you have to hit the ball while it's in the air. If it's too high, it will overshoot the line or hit the net if it is too low.

You can vary the speed, height and direction of shot so, just like the real game, you can lob, smash, volley into a corner or play a gentle drop shot over the net.

One big drawback of the game is the size of the ball used — it's tiny. True, it may be in proportion to the size of the players but it would only have improved the game if this small alteration had been made.

All round, a well produced game which, in spite of a few niggles, still rates as one of my favourite simulations on the Amstrad. Well worth adding to your software collection.

● Graphics	8
● Sound	7
● Value	8
● Playability	8

7 MANIC/JSW

MACHINE: Amstrad
SUPPLIER: Software Projects
PRICE: £5.50

Manic Miner and *Jet Set Willy* have probably made *Miner Willy* the best known computer games character in Britain. If you have been unfortunate enough to own a computer that doesn't have

COMBAT LYNX

From **DURELL**
(Technical Support from
Westland Helicopters)

NEW!
BBC/ELECTRON
AMSTRAD

Spectrum-Commodore 64-BBC/Electron-Amstrad
The ultimate flying experience

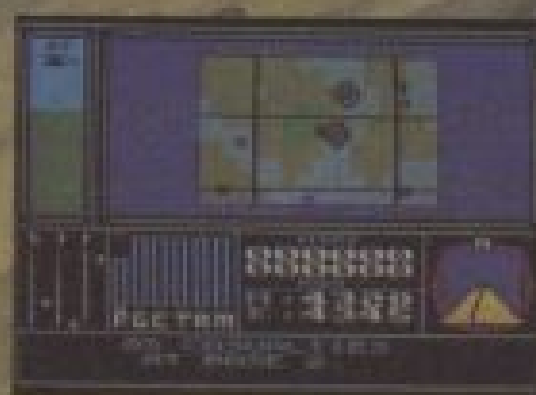
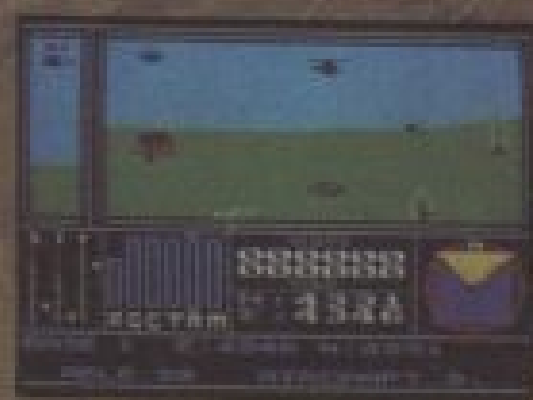

AMSTRAD



BBC/ELECTRON

DURELL sales dept.,
Castle Lodge, Castle Green, Taunton, Somerset, TA1 4AB

NOW AVAILABLE ON THE AMSTRAD

BRIAN JACKS

SUPERSTAR Challenge

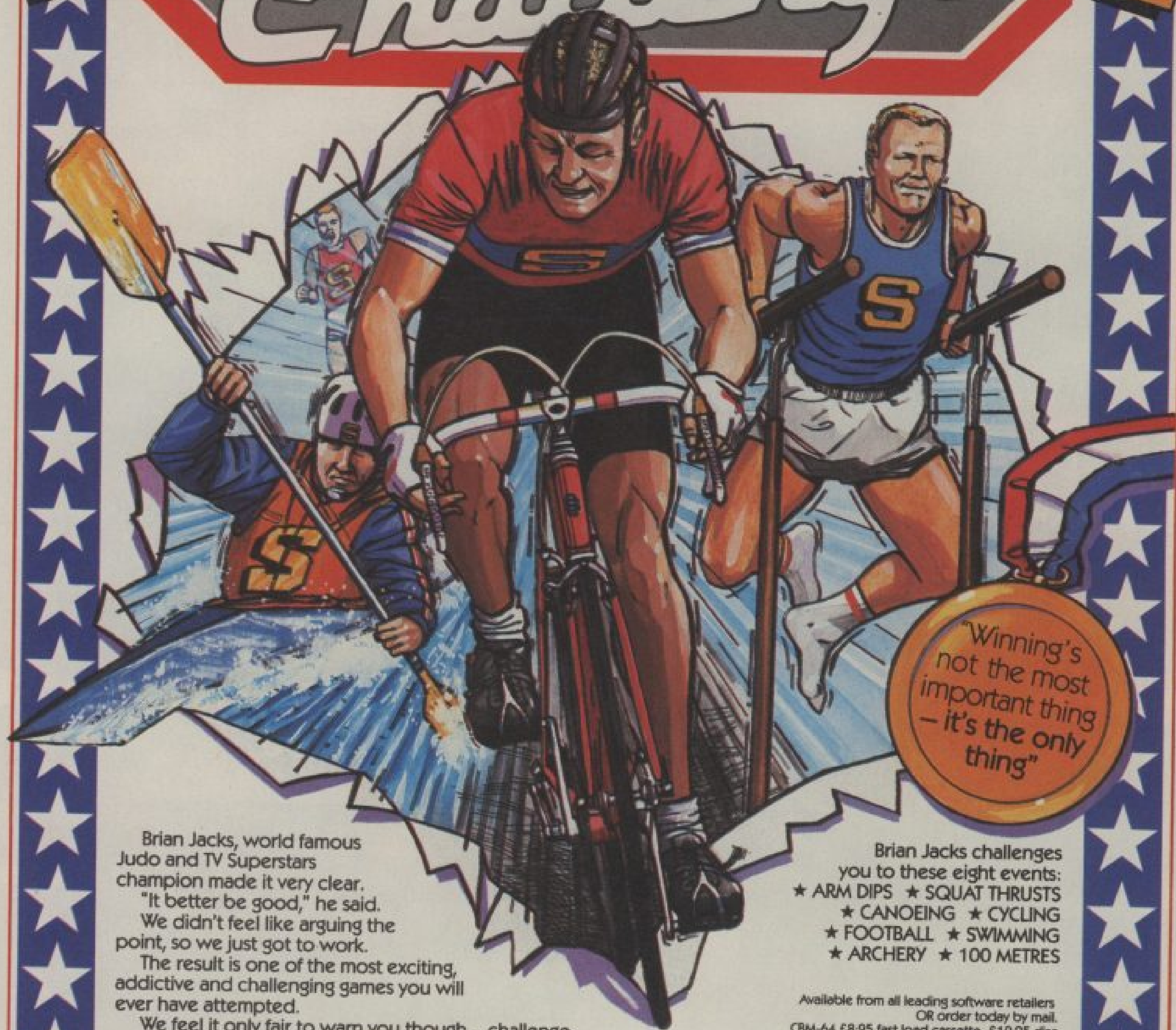

"Winning's
not the most
important thing
- it's the only
thing"

Brian Jacks, world famous
Judo and TV Superstars
champion made it very clear.

"It better be good," he said.

We didn't feel like arguing the
point, so we just got to work.

The result is one of the most exciting,
addictive and challenging games you will
ever have attempted.

We feel it only fair to warn you though - challenge
Brian Jacks to anything and YOU'D better be good!

Brian Jacks challenges
you to these eight events:
★ ARM DIPS ★ SQUAT THRUSTS
★ CANOEING ★ CYCLING
★ FOOTBALL ★ SWIMMING
★ ARCHERY ★ 100 METRES

Available from all leading software retailers
OR order today by mail.
CBM-64 £8.95 fast load cassette £12.95 disc
48K Spectrum/BBC-B/Electron/Amstrad £7.95
prices include VAT & p/p

martech

Martech is the registered trade mark of Software Communications Limited
Martech House, Bay Terrace, Pevensey Bay, East Sussex BN24 6EE

TRADE ENQUIRIES WELCOME. PHONE: (0323) 768456 TELEX: 87465 EXIM Brighton

48K SPECTRUM · COMMODORE 64 · BBC 'B' · ELECTRON · AMSTRAD

AMSTRAD

R·E·V·I·E·W·S

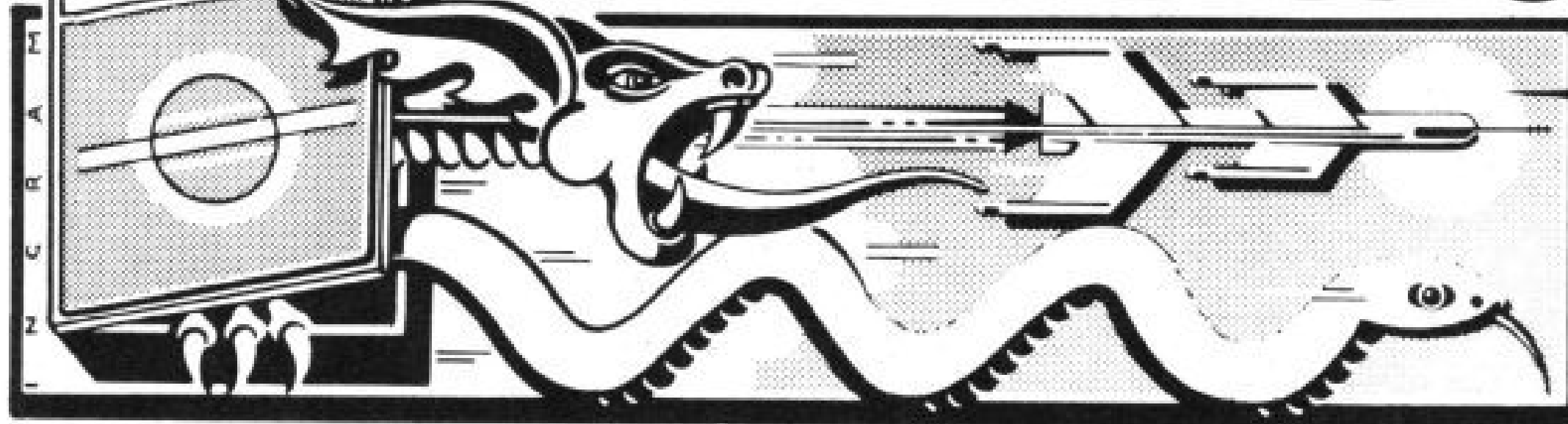

Sound: Does the game sound like a Duran Duran LP played at half speed — or does the noise from your micro knock you half-way across the room? The C&VG review team don't judge games with their ears plugged up, we can tell you!

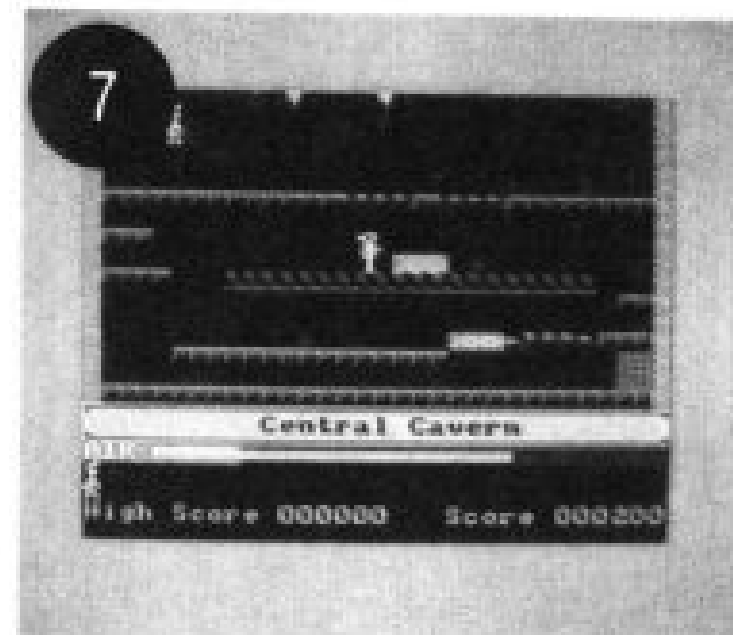

its own adaptation of the game, or you don't own a computer at all, then you've never played a real computer game.

Both games are now available on the Amstrad computer and are almost exactly the same as the Spectrum original. All the platforms and crumbling ledges are there, as well as the man-eating toilets, mutant telephones boxes and boncing penguins.

The aim of the game is fairly simple. You must guide Miner Willy through 20 levels of a disused mine which is being run by a workforce of robots. Sounds simple. It isn't.

On each and every level there are several different flashing keys which have to be collected before the door to the next level opens up. Things are made difficult by monsters patrolling the mine shafts, platforms that crumble under your feet, sending you crashing to the bottom of the mine and poisonous mushrooms which kill Willy on the slightest contact.



It took several months for the first person to crack the Spectrum version of the game and discover the game's secret. I'm sure Amstrad owners will have as much of an entertaining and

frustrating time as thousands of Spectrum and Commodore owners did. Even after nearly two years on the market, *Manic Miner* is still as exciting and novel as the day it was released.

The sequel, *Jet Set Willy*, also stayed at the top of C&VG's charts throughout the summer and was almost universally praised. I personally thought the game was quite an anti-climax following all the speculation before its release. Software Projects have reproduced the game very accurately, though, and I'm sure it will be sailing quite high up the charts again.

● Graphics	9
● Sound	8
● Value	8
● Playability	9

8 STAR AVENGER

MACHINE: Amstrad
SUPPLIER: Kuma Computing
PRICE: £6.95

Unlike most computers that have emerged during the past three or four years, the Amstrad is almost the only computer to have a substantial software catalogue already available for it at the launch of the machine.

This means that conversions of well known computer and arcade games take some time to appear. *Star Avenger* is typical of the fast movement in Amstrad games and is a complete conversion of the arcade game *Scramble* with lots of extra features added, too.

The aim of the game is guide your rocket ship through a guarded underground fortress. First you must break through the outer defences of the city, following up with a bombing run over the city, and then onto the hidden lair of the robot controlling the city's

automated defences to destroy it.

The program also allows you to jump through any of ten or so levels of the game, so you can practice playing a particularly difficult or tricky part.

My first big disappointment with the game is that the controls are solely confined to the keyboard. It is ridiculous that no provision has been made for gamers with joysticks, especially in a game like *Star Avenger*, where a lot of very fine adjustments in direction are often necessary.

Graphically the game is fairly impressive. Lots of colour and rapidly changing scenery help to give the game the touch of an arcade game. Although the animation of the ship is of the same quality, the jerkiness of the movement makes it difficult to negotiate tight corners and also makes hitting rockets and fuel dumps even harder.

Star Avenger is a reasonable shoot-'em-up. It is well worth grabbing a copy for the odd zapping session, although I'm sure that this game is not going to become a classic on the Amstrad.

● Graphics	8
● Sound	6
● Value	7
● Playability	7

9 GHOULS

MACHINE: Amstrad
SUPPLIER: Micro Power
PRICE: £6.95

Ghouls, the latest release from Micro Power, is likely to send shivers down even the most experienced gamer's spine.

The scene is a long deserted and reputedly haunted house on top of an eerie hill. Local gossip says that the last owner of the house was an insane millionaire who hoarded a collection of precious South

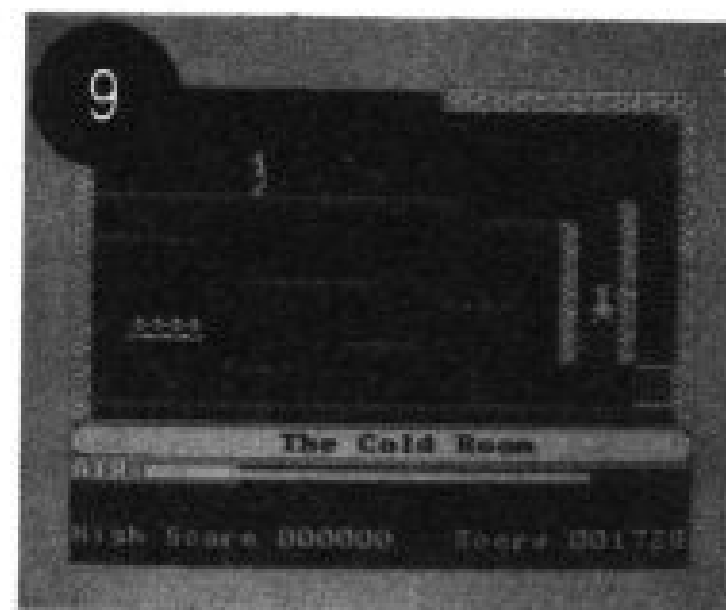

American Inca stones which, apparently, have astonishing magical powers.

Many other adventurers have tried to remove the jewels from the mansion but none have ever emerged alive. It's up to you to enter the house, find your way through the many trap-filled rooms and remove the fabulous treasure.

The insane owner has built in some novel, and horrifying, alterations into the house including poison-smearred spikes, moving floor boards and shrinking floors.

The house is also filled with malevolent ghosts and ghouls which track you down in each room. These can be made to disappear if you find one of the odd gems which have been strewn around the house. This will give you just enough time to make your exit from the room.

Each level is constructed to give you as little chance of reaching the top of the screen as possible.

Ghouls is certainly a tough nut to crack — and I could imagine myself playing for several weeks before becoming even nearly competent. This game does have its drawbacks. Often it becomes extremely frustrating because you need a lot of luck and very little skill in some parts of the game.

Overall, the game scores highly in my ratings and I would recommend it to anyone looking for a good climbing game.

● Graphics	8
● Sound	8
● Value	8
● Playability	8

DOTMAN

RUNS ON AN AMSTRAD

BY STEPHEN SUTHERLAND

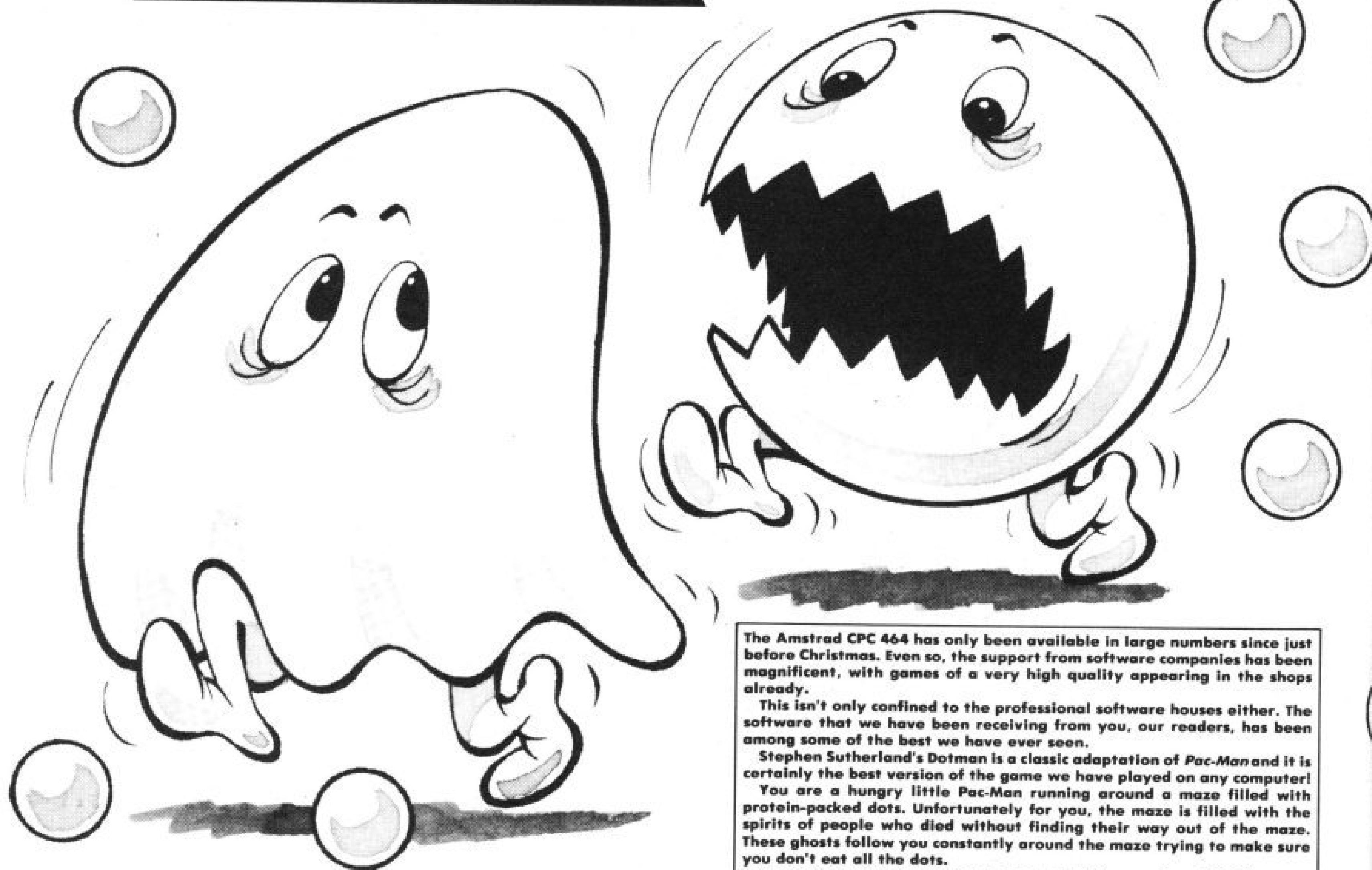

The Amstrad CPC 464 has only been available in large numbers since just before Christmas. Even so, the support from software companies has been magnificent, with games of a very high quality appearing in the shops already.

This isn't only confined to the professional software houses either. The software that we have been receiving from you, our readers, has been among some of the best we have ever seen.

Stephen Sutherland's Dotman is a classic adaptation of Pac-Man and it is certainly the best version of the game we have played on any computer!

You are a hungry little Pac-Man running around a maze filled with protein-packed dots. Unfortunately for you, the maze is filled with the spirits of people who died without finding their way out of the maze. These ghosts follow you constantly around the maze trying to make sure you don't eat all the dots.

Happy chomping, but remember not to let the guests eat YOU!

```
10 REM*****
*****
20 REM DOTMAN (C) 1984 Stephen S
  utherland
30 REM*****
*****
40 GOSUB 1300:REM START
50 GOSUB 1880:REM INSTRUCTIONS
60 GOSUB 1600:REM SCREEN
70 FOR f=1 TO liv:LOCATE 7+(2*f)
  ,12:PRINT a1$(1):LOCATE 7+(2*f),
  13:PRINT a2$(1):NEXT f
80 q=10:P=16:q1=2:q2=2:c=2:d=2:t
  =19:s=2:mo=1:op=P:oq=q:ot=t:os=s
  :da=1:RESTORE
90 ON scr GOTO 100,150,200
100 GOSUB 940
110 IF c=q AND d=P THEN 790
120 GOSUB 350
130 IF sc!<>0 AND sc!/o!=INT(sc!
  /o!) THEN CLS:o!=sc!+5150:scr=sc
  r+1:GOTO 60 ELSE 100
140 IF c=q AND d=P THEN 790
150 GOSUB 1100
```

```
160 IF P=s AND q=t THEN 790
170 GOSUB 350
180 IF P=s AND q=t THEN 790
190 IF sc!<>0 AND sc!/o!=INT(sc!
  /o!) THEN CLS:o!=sc!+5150:scr=sc
  r+1:GOTO 60 ELSE 150
200 GOSUB 1100
210 IF (c=q AND d=P) OR (s=P AND
  t=q) THEN 790
220 GOSUB 350
230 IF (c=q AND d=P) OR (s=P AND
  t=q) THEN 790
240 IF sc!<>0 AND sc!/o!=INT(sc!
  /o!) THEN CLS:o!=sc!+5150:scr=1:
  IF liv<3 THEN liv =liv+1
250 IF scr=1 THEN 60
260 GOSUB 1100
270 IF (c=q AND d=P) OR (s=P AND
  t=q) THEN 790
280 GOSUB 350
290 IF (c=q AND d=P) OR (s=P AND
  t=q) THEN 790
300 GOSUB 940
310 IF (c=q AND d=P) OR (s=P AND
  t=q) THEN 790
```

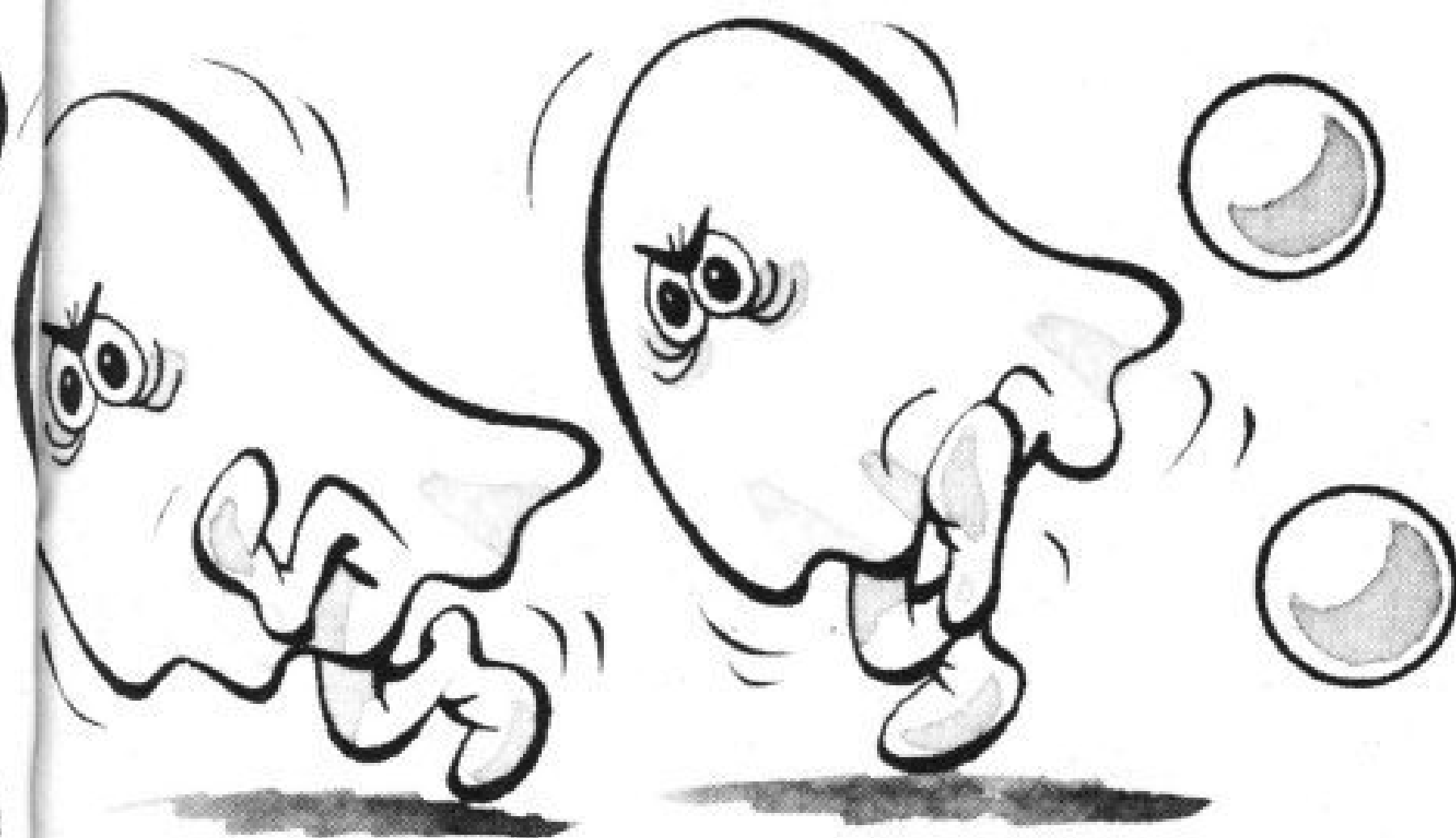

```

320 IF sc!<>0 AND sc!/o!=INT(sc!
/o!) THEN CLS:o!=sc!+5150:scr=1:
IF liv<3 THEN liv=liv+1
330 IF scr=1 THEN 60 ELSE 200
340 REM *** MOVE DOTMAN ***
350 PEN 4:LOCATE q,p:PRINT a1$(m
o):LOCATE q,p+1:PRINT a2$(mo)
360 op=p:oq=q
370 IF JOY(0)=1 THEN x=p:y=q:GOS
UB 580:IF col=0 THEN p=p-2
380 IF JOY(0)=2 THEN x=p:y=q:GOS
UB 660:IF col=0 THEN p=p+2
390 IF JOY(0)=4 THEN q=q-1:a1$(1
)=CHR$(216):a2$(1)=CHR$(217):ox=
op:oy=oq:GOSUB 530:IF col=1 THE
N q=q+1
400 IF JOY(0)=8 THEN q=q+1:a1$(1
)=CHR$(212):a2$(1)=CHR$(213):che
=1:ox=op:oy=oq:GOSUB 530:che=0:
IF col=1 THEN q=q-1
410 IF op=p AND oq=q THEN mo=1:G
OTO 440
420 mo=(2-mo)+1
430 PEN 1:LOCATE 1,25:PRINT"Scor
e :-";USING"#####";sc!:LOCATE o
q,op:PRINT" ":LOCATE oq,op+1:PRI
NT" "
440 IF t=c AND s=d AND scr<>2 TH
EN q1=q2
450 IF p=12 AND q=21 THEN q=1:SO
UND 2,200,25,7,0,1
460 IF p=12 AND q=0 THEN q=20:SO
UND 2,200,25,7,0,1
470 IF op=p AND oq=q THEN 510
480 x=p:y=q
490 GOSUB 740
500 IF po=1 THEN SOUND 1,100,2:s
c!=sc!+50
510 RETURN
520 REM ***TESTS***
530 px=((oy-1)*32)-1:py=((26-ox)
*16)-22
540 IF che=1 THEN px=px+36
550 IF TEST (px,py)<>0 THEN col=
1:RETURN

```

```

560 col=0
570 RETURN
580 px=((y-1)*32):py=((26-x)*16)
+1
590 px1=px+24
600 px2=px+12
610 IF TEST (px,py)<>0 THEN col=
1:RETURN
620 IF TEST (px2,py)<>0 THEN col
=1:RETURN
630 IF TEST (px1,py)<>0 THEN col
=1:RETURN
640 col=0
650 RETURN
660 px=((y-1)*32):py=((26-x)*16)
-33
670 px1=px+24
680 px2=px+12
690 IF TEST (px,py)<>0 THEN col=
1:RETURN -
700 IF TEST (px1,py)<>0 THEN col
=1:RETURN
710 IF TEST (px2,py)<>0 THEN col
=1:RETURN
720 col=0
730 RETURN
740 px=((y-1)*32)+12:py=((26-x)*
16)-16
750 IF TEST (px,py)<>0 AND TEST
(px+12,py)=0 THEN po=1:RETURN
760 po=0
770 RETURN
780 REM *** KILLED ***
790 IF scr<>1 THEN PEN 1:LOCATE
ot,os:PRINT b1$(q1):LOCATE ot,os
+1:PRINT b2$(q1)
800 LOCATE oq,op:PRINT" ":LOCATE
oq,op+1:PRINT" "
810 LOCATE q,p:PRINT a1$(2):LOCA
TE q,p+1:PRINT a2$(2)
820 l=((q-1)*32)+16:m=((26-p)*16
)-16
830 DEG
840 SOUND 1,100,200,7,0,2
850 FOR f=180 TO 0 STEP -8
860 PLOT l,m,0:DRAWR 14*COS(f-90
),14*SIN(f-90),0
870 PLOT l,m,0:DRAWR -(16*COS(f-
90)),14*SIN(f-90),0
880 NEXT
890 FOR f=1 TO 500:NEXT
900 liv=liv-1:IF liv>0 THEN o!=s
c!+5150:GOTO 60
910 PAPER 2:PEN 0:LOCATE 4,1:PRI
NT"HIT SPACE BAR":PEN 1:PAPER 0
920 WHILE INKEY$<>" ":WEND
930 scr=1:sc!=0:liv=3:o!=5150:GO
TO 60
940 REM *** ROBOT GHOST ***
950 PEN 1:LOCATE c,d:PRINT b1$(q
2):LOCATE c,d+1:PRINT b2$(q2)

```

```

960 READ c,d
970 da=da+1:IF da=259 THEN RESTO
RE 1010:da=1
980 IF c=t AND d=s AND scr=3 THE
N 92=91 ELSE x=d:y=c:GOSUB 740:9
2=po+1
990 PEN 2: LOCATE c,d:PRINT CHR$(
(210)):LOCATE c,d+1:PRINT CHR$(21
1):PEN 4
1000 RETURN
1010 DATA 2,2,3,2,4,2,4,4,4,6,4,
8,5,8,5,10,5,12,5,14,5,16,6,16,7
,16,8,16,9,16,10,16,11,16,12,16,
13,16,14,16,15,16,17,16,18,16,19
,16,19,18,19,20,19,22
1020 DATA 18,22,17,22,17,20,17,1
8,17,16,16,16,16,14,16,12,16,10,
16,8,17,8,18,8,19,8,19,6,19,4,19
,2,18,2,17,2,16,2,15,2,14,2,13,2
,12,2,12,4,12,6,11,6,10,6,9,6,8,
6,8,8
1030 DATA 7,8,6,8,5,8,5,10,5,12,
5,14,5,16,4,16,3,16,2,16,2,18,2,
20,2,22,3,22,4,22,4,20,5,20,6,20
,7,20,7,22,8,22,9,22,10,22,11,22
,12,22,13,22,14,22,14,20,15,20,1
6,20,17,20
1040 DATA 17,18,17,16,16,16,16,1
4,16,12,17,12,18,12,19,12,20,12,
1,12,2,12,3,12,4,12,5,12,5,10,5,
8,4,8,4,6,4,4,4,2,5,2,6,2,7,2,8,
2,9,2,9,4,9,6,10,6,11,6,12,6,12,
4,12,2,13,2,14,2,15,2,16,2,17,2,
18,2,19,2,19,4,19,6,19,8,18,8,17
,8,16,8,16,10
1050 DATA 16,12,16,14,16,16,17,1
6,18,16,19,16,19,18,19,20,19,22,
18,22,17,22,17,20,16,20,15,20,14
,20,14,22,13,22,12,22,11,22,10,2
2,9,22,8,22,7,22,7,20,6,20,5,20,
4,20,4,18,4,16,5,16,5,14,5,12,4,
12,3,12,2,12,1,12
1060 DATA 20,12,19,12,18,12,17,1
2,16,12,16,10,16,8,15,8,14,8,13,
8,13,6,12,6,11,6,10,6,9,6,9,4,9,
2,8,2,7,2,6,2,5,2,4,2,3,2,2,2,2,
4,2,6,2,8,3,8,4,8,5,8,5,10,5,12,
5,14,5,16,6,16,7,16,8,16,9,16,10
,16,11,16,12,16,13,16,14,16,15,1
6,16,16,16,14,16,12,16,10,16,8
1070 DATA 15,8,14,8,13,8,13,6,12
,6,12,4,12,2,13,2,14,2,15,2,16,2
,17,2,17,4,17,6,17,8,16,8,16,10
1080 DATA 16,12,16,14,16,16,15,1
6,14,16,13,16,12,16,11,16,10,16,
9,16,8,16,7,16,6,16,5,16,5,14,5,
12,5,10,5,8,4,8,3,8,2,8,2,6,2,4
1090 REM *** FOLLOWING GHOST ***
1100 flag=0
1110 IF RND<0.5 THEN flag=1:GOTO
1140

```



```

1120 IF t>9 THEN ox=s:oy=t:che=0
:GOSUB 530:IF col=0 THEN t=t-1:
GOTO 1260
1130 IF t<9 THEN ox=s:oy=t:che=1
:GOSUB 530:che=0:IF col=0 THEN
t=t+1:GOTO 1260
1140 IF s>P THEN x=s:y=t:GOSUB
580:IF col=0 THEN s=s-2:GOTO 126
0
1150 IF s<P THEN x=s:y=t:GOSUB
660:IF col=0 THEN s=s+2:GOTO 126
0
1160 IF t+1=9 AND s=P THEN t=t+1
:GOTO 1260
1170 IF s-1=P AND t=9 THEN s=s-1
:GOTO 1260
1180 IF t-1=9 AND s=P THEN t=t-1
:GOTO 1260
1190 IF s+1=P AND t=9 THEN s=s+1
:GOTO 1260
1200 IF flag=1 THEN flag=0:GOTO
1120
1210 IF s=os AND t=ot THEN ra=RN
D*3 ELSE 1260
1220 IF ra=0 THEN ox=s:oy=t:GOSU
B 530:IF col=0 THEN t=t-1
1230 IF ra=1 THEN ox=s:oy=t:che=
1:GOSUB 530:che=0:IF col=0 THEN
t=t+1
1240 IF ra=2 THEN x=s:y=t:GOSUB
580:IF col=0 THEN s=s-2
1250 IF ra=3 THEN x=s:y=t:GOSUB
660:IF col=0 THEN s=s+2
1260 IF t<>ot OR s<>os THEN PEN
1:LOCATE ot,os:PRINT b1$(91):LOC
ATE ot,os+1:PRINT b2$(91):x=s:y=
t:GOSUB 740:91=po+1:PEN 3:LOCAT
E t,s:PRINT CHR$(210):LOCATE t,s
+1:PRINT CHR$(211)
1270 ot=t:os=s
1280 RETURN
1290 REM *** START ***
1300 DEFINT a-z
1310 ENT 2,100,10,2
1320 ENT 1,25,-8,1
1330 SYMBOL AFTER 200
1340 SYMBOL 200,129,129,129,129,
129,129,129,129
1350 SYMBOL 201,255,0,0,0,0,0,0,
255
1360 SYMBOL 202,224,24,4,2,2,1,1
,129
1370 SYMBOL 203,129,1,1,2,2,4,24
,224
1380 SYMBOL 204,7,24,32,64,64,12
8,128,129
1390 SYMBOL 205,129,128,128,64,6
4,32,24,7
1400 SYMBOL 206,0,0,0,0,0,0,24,2
4
1410 SYMBOL 207,24,24,0,0,0,0,0,
0

```

One of America's most popular games
THE ULTIMATE IN BATTLE ACTION..

BEACH-HEAD™

AMSTRAD

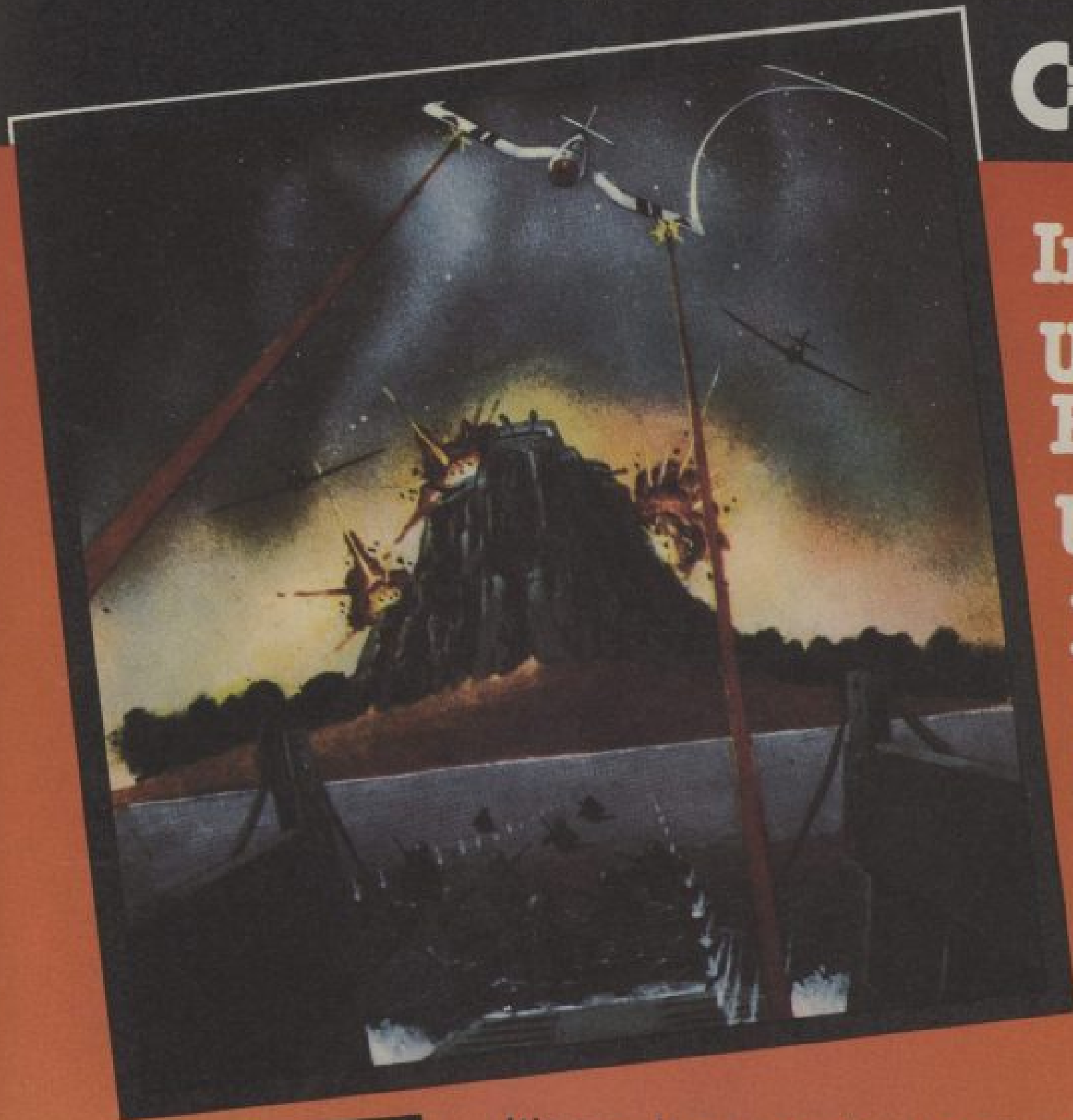

Incredible 3-D Graphics

Unbelievable Sound Effects

Unique Games Concept

Multiple Screens

High Resolution Scenario

100% Machine Language

Voted by U.S. Billboard magazine as the best game for sound and graphics on the Commodore 64

It's a unique arcade experience in sound and vision and a stunning display of Amstrad capabilities.

Another quality product from **ACCESS Software.**



Available on **CASSETTE** & **9.95** for **AMSTRAD**

THE ULTIMATE IN AMERICAN SOFTWARE FOR YOU ON U.S. GOLD

U.S. Gold is stocked by all leading computer stores including:

BOOTS WHSMITH JOHN MENZIES WILDINGS WOOLWORTH

DEALERS! For information on how to become a U.S. Gold Stockist write to: CentreSoft Ltd., Unit 10, The Parkway Industrial Centre, Heneage Street, Birmingham B7 4LY. Telephone: 021-359 3020. Telex: 337268. Overseas enquiries welcome.

U.S. GOLD
All American Software

FDRANK



STREET HAWK



Daley Thompson's



SPECTRUM 48K · COMMODORE 64

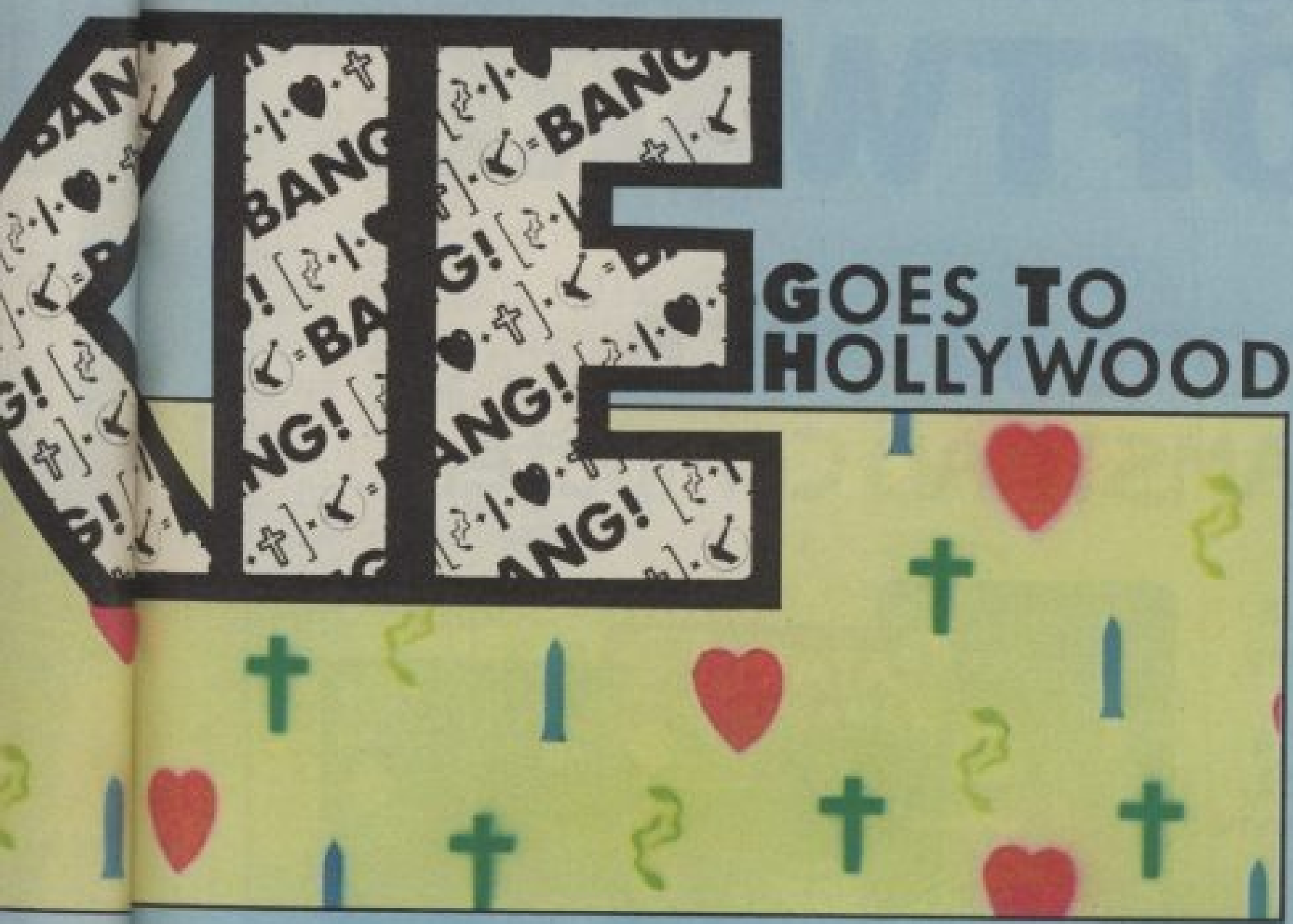

BRAND
NEW
BIG
NAMES
BIG
GAMES

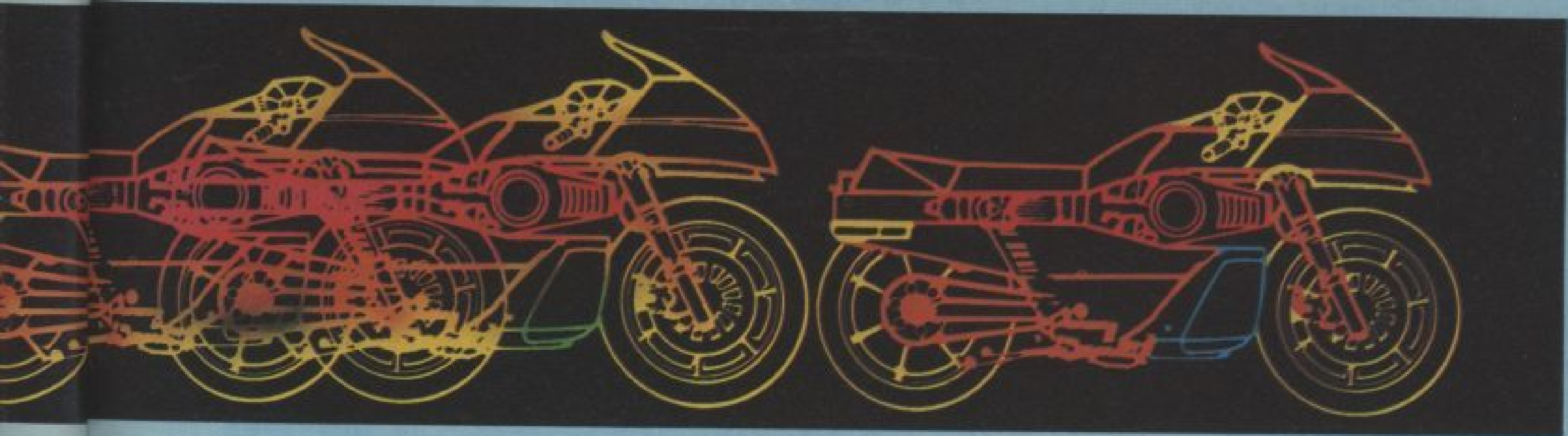

SUPER
TEST

Exciting
times ahead
from the
crew at...



A message from ENGLISH SOFTWARE™

ATARI, COMMODORE 64, BBC B, ACORN ELECTRON and AMSTRAD Computers...

Software companies grow on trees ... at least that's the way it seems from the number of new companies springing up every week!

ENGLISH SOFTWARE was launched three years ago with a smashing little game for Atari Computers called **AIRSTRIKE 1**, which quickly became one of the most popular U.K. programmed games for the Atari.

Then, as now, Atari Computers were amongst the most advanced on the planet, but they were a **TRIFLE expensive!** But we knew that prices would come down, and that more people would soon appreciate the great range of Atari software produced by **ENGLISH SOFTWARE**. But Atari owners **used** to be a funny lot, being heard to utter such gems as:

"It can't be any cop, if it costs less than £20"

Honestly, that's what they used to say! Anyway, in the face of this rather strange attitude, we went ahead and committed the ultimate sin:

ATARI GAMES AT £9.95!

We expected some slight resistance to these prices from Atari owners who only equated high quality with high prices, but we were wrong: Everybody thought the prices were great, and the games too!

We even produced the fantastic **ATARI CASSETTE ENHANCER** at £7.95, a superb utility program for **BASIC** programmers.

So now, for those of you who might have missed out on all our excellent Atari titles, we are releasing something very, very special:

ATARI SMASH HITS Volumes 1, 2 and 3 from **ENGLISH SOFTWARE**.

Five great games on one cassette for only £14.95, or on disk at £17.95!

Each cassette features our top-rated **JET-BOOT JACK** plus four other popular titles. So now you have no excuse to miss out on the best range of U.K. produced Atari 400/800/600XL/800XL software for 32K machines. If your dealer does not yet have them in stock, ask him to order them from his nearest Atari wholesaler. It will be the best Atari buy **YOU** will make all year!

We have also just released **COLOSSUS CHESS 3.0**, the best chess program available anywhere for Atari 400/800/600XL/800XL computers with 48K. Very powerful, with lots of excellent features.

For our good friends with other home computers, our programmers are busy producing original games for you as well. They are all illustrated on this page. **HENRY'S HOUSE** on the Commodore 64, and **JET-BOOT JACK** on the Electron are now available at selected branches of **W.H. SMITH**.

Selected English Software titles are available at: HARRODS and selected branches of: LASKY'S, BOOTS, GRANADA COMPUTER STORES, CO-OP STORES, THE SILICA SHOP Mail Order and Retail and all good software stores.

THE ENGLISH SOFTWARE COMPANY
1 North Parade, Parsonage Gardens, Manchester M60 1BX
TRADE ENQUIRIES WELCOME: 061-835 1358



ENGLISH SOFTWARE™
ENGLISH SOFTWARE™
ENGLISH SOFTWARE™
ENGLISH SOFTWARE™
ENGLISH SOFTWARE™
ENGLISH SOFTWARE™

```

1420 SYMBOL 208,24,36,66,66,129,
129,129,129
1430 SYMBOL 209,129,129,129,129,
66,66,36,24
1440 SYMBOL 210,0,24,60,126,126,
255,219,219
1450 SYMBOL 211,255,255,255,255,
219,73,73,0
1460 SYMBOL 212,0,24,126,126,255
,254,252,248
1470 SYMBOL 213,248,252,254,255,
126,126,24,0
1480 SYMBOL 214,0,24,126,126,255
,255,255,255
1490 SYMBOL 215,255,255,255,255,
126,126,24,0
1500 SYMBOL 216,0,24,126,126,255
,127,63,31
1510 SYMBOL 217,31,63,127,255,12
6,126,24,0
1520 INK 0,0:INK 1,26:INK 2,11,2
5
1530 INK 3,11:INK 4,24
1540 DIM a1$(2),a2$(2),b1$(2),b2
$(2):sc!=0
1550 o!=5150
1560 a1$(1)=CHR$(212):a2$(1)=CHR
$(213):a1$(2)=CHR$(214):a2$(2)=C
HR$(215):b1$(1)=" ":b2$(1)=" ":b
1$(2)="N":b2$(2)="0"
1570 scr=1:liv=3
1580 RETURN
1590 REM *** SCREEN ***
1600 PEN 1:PAPER 0:BORDER 1:MODE
0
1610 PRINT "LIIIIIIIIJLIIIIIIIIJ
"
1620 PRINT "HNNNNNNNNHHNNNNNNNNH
"' precede
1630 PRINT "HOOOOOOOOHHOOOOOOOOH
"
1640 PRINT "HNPNLIIJNHHNLIJNPNH
"' each
1650 PRINT "HOHOH LKOMKOMJ HOHOH
"
1660 PRINT "HNHNH HNNNNNNH HNHNH
"' of
1670 PRINT "HOQOMIKOOOOOMIKOOQH
"
1680 PRINT "HNNNNNNNLIJNNNNNNNH
"' these
1690 PRINT "HOOOOOOOH HOOOOOOOH
"
1700 PRINT "MIIJNLIK MIIJNLIK
"' PRINTS
1710 PRINT "IIIKOH HOMIII
"
1720 PRINT " NNNNH HNNNN
"'(1620-1840)
1730 PRINT " OOOOH HOOOO
"

```

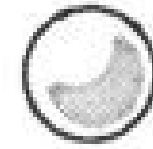
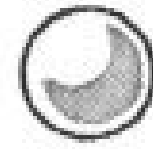

```

1740 PRINT "IIIJNH HNLIII
"' with
1750 PRINT "LIIKOMIIIIIIIIKOMIJJ
"
1760 PRINT "HNNNNNNNNNNNNNNNNNNNH
"' a
1770 PRINT "HOOOOOOOOOOOOOOOOOOOH
"
1780 PRINT "HNPNLIIIIIIIIIIJNPNH
"' CTRL [K]
1790 PRINT "HOHOMIJJ LIKOHOH
"
1800 PRINT "HNNNNNNH HNNNNNNH
"' character
1810 PRINT "HOQOOOOMIIIIKOOOOQOH
"
1820 PRINT "HNNNLJNNNNNNNNLJNNNH
"' (upwards)
1830 PRINT "HOOHHOOOOOOOOHHOOOH
"
1840 PRINT "MIIIKMIIIIIIIIKMIIIK
"' arrow)
1850 PEN 4:LOCATE 1,25:PRINT"Sc
ore :-";USING"#####";sc!
1860 RETURN
1870 REM ***INSTRUCTIONS***
1880 MODE 1
1890 PAPER 0:PEN 2:LOCATE 17,2:P
RINT"DOTMAN"
1900 PEN 1
1910 PRINT:PRINT" Use the joysti
ck to move the 'dotman'"
1920 PRINT"around the maze,eatin
g the dots,"
1930 PRINT"and avoiding the ghos
ts."
1940 PRINT:PRINT" Each dot eaten
scores 50 points."
1950 PRINT:PRINT" After all the
dots have been eaten,"
1960 PRINT"you move on to the ne
xt stage,until,"
1970 PRINT"after the 3rd stage,t
he game repeats."
1980 PRINT:PRINT" The 3 stages a
re as follows:-"
1990 PRINT:PRINT" 1) A 'robot
' ghost patrols the maze."
2000 PRINT:PRINT" 2) A ghost
will chase you about the
maze."
2010 PRINT:PRINT" 3) Both gho
sts together."
2020 PEN 0:PAPER 2
2030 LOCATE 7,25:PRINT"HIT THE
SPACE BAR TO START"
2040 WHILE INKEY$(">)" ":WEND:PEN
1:PAPER 0
2050 RETURN
2060 SPEED WRITE 1:SAVE "DOTMAN"
:SPEED WRITE 0:SAVE "DOTMAN"

```

```

0 CLR:W=INT(RND(1)*50):G=0:SC=0
1 PRINT "L":POKE 53281,2:POKE 53280,2
2 PRINT "
3 PRINT "
4 PRINT "
5 PRINT "
6 PRINT "
7 PRINT "
8 PRINT "
9 INPUT "HOW MANY GOS" :P
10 INPUT "LEVEL (1/2)":LEV
11 GOSUB 4500
25 PRINT "SCORE :";SC
26 PRINT "
27 PRINT "
28 PRINT "
29 PRINT "
30 PRINT "

```

BY MARTYN JOYCE

```

41 A=0:
45 PRINT "
46 PRINT "
47 PRINT "
50 PRINT "
55 IF LEV=2 THEN W=INT(RND(1)*50)
60 PRINT "WIND FORCE :";W
61 INPUT "TYPE IN AIM :";A
62 G=G+1:IF G>P THEN GOT02050
65 GOSUB 1010:GOSUB 2000
7010 POKE 54296,15
7020 POKE 54277,1:POKE 54278,255:POKE 54276,129:POKE 54273,1:POKE 54272,10
1030 FOR I=1 TO 100:NEXT:FOR K=15 TO 0 STEP -5:POKE 54295,K:NEXT K:POKE 54272,0:POKE 54276,0
2000 POKE 1464+A+W+150,102:POKE 55736-(A+W+150),0:FOR I=1 TO 1000:NEXT
2005 IF 1464+A+W+150=1610 THEN GOSUB 7000:GOSUB 12011:GOSUB 8000:GOSUB 30000:GOSUB 29999
2010 GOSUB 10000:FOR I=1 TO 1000:NEXT:GOTO 2
2040 PRINT "SCORE :";SC:FOR I=1 TO 1000:NEXT:GOTO 11
2050 POKE 53281,0:POKE 53280,0:PRINT "

```



You have finished your three year training course in the army's finest tank regiment. Today is the final part of your assessment exams and is the final, and hardest, hurdle you have to clear to claim the famous red beret.

Strapped into the gunners' seat, you must destroy a mock up of a small village in central Europe. Your ultimate target is a large house on a hill overlooking the village which has been taken over by enemy troops, and is being used as a permanent headquarters.

Your job is made more difficult by the changing speed of the wind. You must work out the distance of the target and take into account the wind before you fire the shell, because the wind speed and direction can change so rapidly.

There are two levels — in level one there is a constant wind speed and direction and in level two there is a constantly shifting wind speed and direction. The number you enter into the guidance computer of your gun can be positive or negative.

RUNS ON A COMMODORE 64

BY MARTYN JOYCE

```

YOU SCORED :";SC
2060 PRINT"ANOTHER GO?"
2070 GET K$:IFK$=""THEN 2070
2080 IFK$="Y"THEN RUN
2090 IFK$<"N"THEN END
3007 PRINT"V":POKEV+4,150:POKEV+5,119:FO
RI=1T0100:NEXT:POKE 53200,INT(RND(1)*15)
3008 POKE 53201,INT(RND(1)*15)
4000 GETA$:IFA$=""THEN3007
4010 IFA$<"N"THEN CLR:RUN
4500 PRINT"V"
4501 V=53248:POKEV+21,4:POKE2042,10
4502 FORN=0T062:READQ:POKE832+N,Q:NEXT
4503 POKEV+4,24:POKEV+5,100
4504 POKE V+23,4:POKEV+29,4:POKEV+41,12
5000 DATA0,0,0,0,0,0,0,0,0,0,0,0,0,0,0
,0,2,0,0,4,0,0,0,0,0,16,0,0,32,0,30,64
5001 DATA 3,255,128,0,255,128,124,126,0,
127,255,252,64,0,2,43,109,148,19
5002 DATA109,136,15,255,240,0,0,0,0,0
5100 RETURN
7000 Z=24:X=100
7001 FORI=1T0150STEP.5:POKEV+4,Z+I:NEXT
7002 POKEV+4,Z:POKEV+5,X:POKEV+41,12:RET
URN
8000 POKE 53201,1:POKE 52100,1:POKE53201
,2:POKE53200,2

```

```

9000 POKE54296,15:POKE54276,0:POKE54276,
129:FORI=1T0100STEP.2:POKE54273,I:NEXT:
9001 FORI=30T00STEP-.5:POKE54273,I:NEXT
9002 FORI=1T0300:NEXT:POKE54273,0
9003 RETURN
10000 POKE 1464+A+W+150,32:RETURN
12011 PRINT"
12020 PRINT"
12021 PRINT"
12030 SC=SC+10:RETURN
12500 REM *****
12505 REM *****
12506 REM **
12510 REM ** T A N X 6 4 **
12511 REM **
12520 REM ** BY MARTYN JOYCE **
12530 REM **
12540 REM *****
12545 REM *****
12600 END
29999 POKE 54296,15
30000 POKE54276,33:FORI=0T0255STEP10:FOR
T=0T0100:POKE54273,I:NEXTI
30001 POKE 54296,0:POKE54273,0:RETURN

```

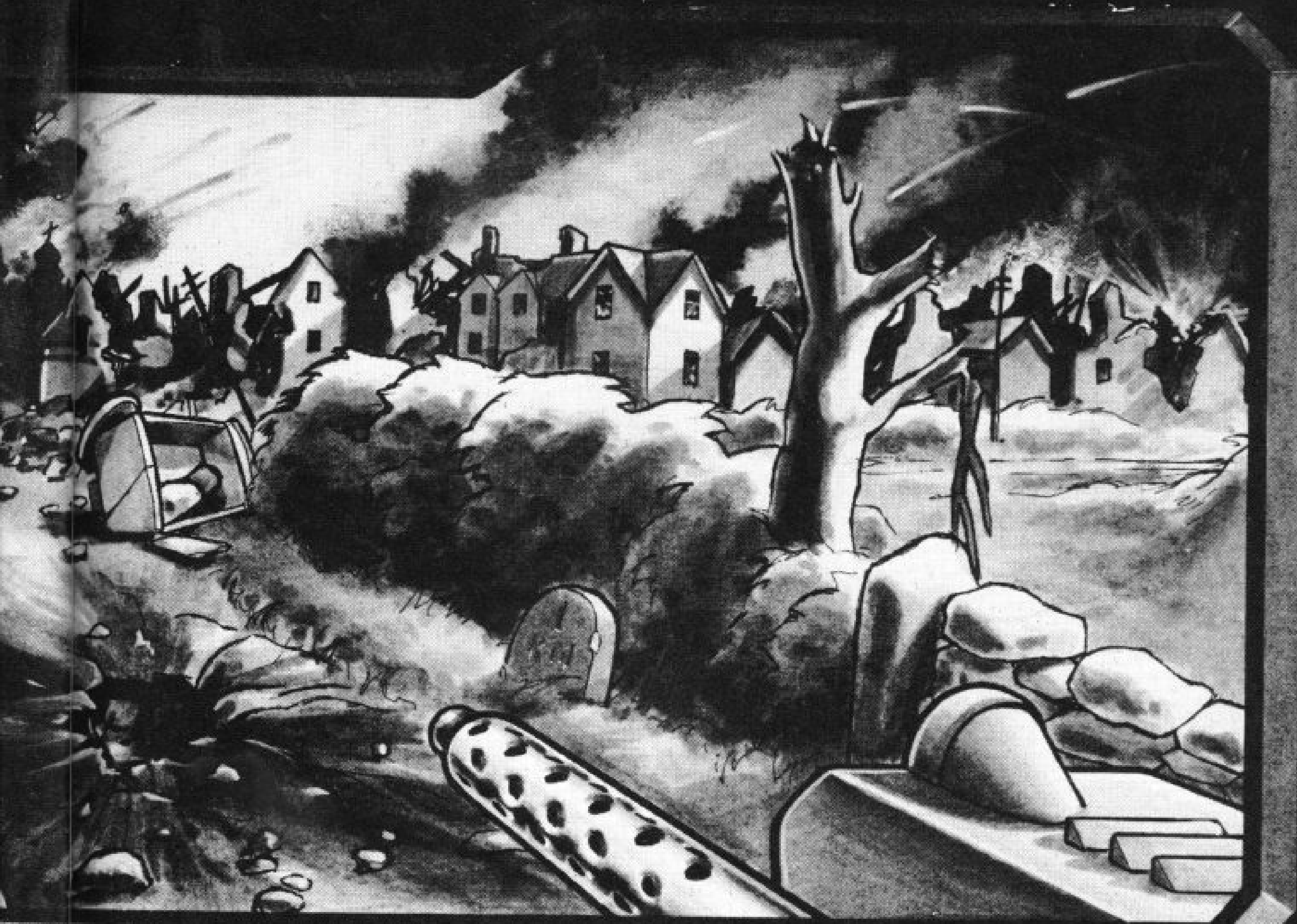

TANX 64

THE HOBBIT CONTEST



The Hobbit is a classic book — and a classic Adventure game! Philip Mitchell's computerised version of Tolkien's fantasy has become the standard for other graphic Adventures to reach since its release a couple of years ago.

Now the game is available for most popular home computers — and our mates at Melbourne House have offered us 50 copies of the game for the winners of our grand *Hobbit* competition. Not only do you get the game but also a copy of the paperback *Hobbit* book complete with Tolkien's own illustrations. Not bad eh?

Disc versions of the game for the Beeb and CBM 64 are now available — and both have a few new tweaks added. There are also new versions for MSX and Amstrad as well as cassette-based games for the BBC, CBM 64, Spectrum, and Oric/Atmos.

How do you get your hands on one? Just answer Bilbo's questions below, fill in the coupon and rush it to *Computer & Video Games*, Hobbit Competition, Priory Court, 30-32 Farringdon Lane, London EC1R 3AU.

Closing date for the competition is May 16th, normal C&VG rules apply and the editor's decision is final. As usual!

BILBO'S QUESTIONS

1. Name three of the dwarves who set out on the Adventure to the Lonely Mountain with Bilbo.
2. What creatures did Bilbo and the dwarves get tangled up with while travelling through Mirkwood?
3. What did Bilbo find in the goblin's tunnels and what powers did this object have?
4. What is the name of Bilbo's nephew and main character in *Lord of the Rings*, the epic sequel to *The Hobbit*?

C&VG/MELBOURNE HOUSE HOBBIT COMPETITION.

My answers are:

- 1.....
- 2.....
- 3.....
- 4.....

Name.....

Address.....

Computer I own: CBM 64, Spectrum, BBC, MSX, Oric/Atmos, Amstrad.

Would you prefer disc or cassette?.....

THE LIVING ADVENTURE MOVIE

With
SENSORY ANIMATION

DRAGONTORC

THE LOST REALMS OF THE DRAGONTORC



Morag the Shapeshifter has seized the Crown of Dumnovia and is out to find the other four crowns that make up the Kingdom of Britain. The five crowns were struck from the legendary Dragontorc of Avalon in the distant past, and if brought together again will allow the keeper fantastic power. Morag intends to control this Torc of Power and subject Saxon Britain to decades of tyranny. However, you can take the role of Maroc and Mage, seek out the remaining crowns, combat Morag and release your old tutor

Meryn from her evil spell. On your travels through the strife torn kingdoms you can develop magical powers to help you understand and master the mysteries of landmarks like the Giant Ring of Stones, and the Secret Crypts. The leylines, which can be plotted on the accompanying map, will be your main route to the crowns. And for the first time in any adventure game you'll encounter Sensory Animation! This programming break-through has given lifelike

emotions to the multitude of characters in the game - cross them too often and any chance you have of beating Morag to the crowns may be dashed forever. Add to this a FREE map and scenario full of clues, hundreds of locations, all in 3D, over 200 different discoveries to make, and you have a stunning adventure it could take you a lifetime to complete! Dragontorc of Avalon - The Living Adventure Movie - Available for the 48K Spectrum and Spectrum+. Only £7.95.



Arcade Adventure with TECHNICIAN TED

Try to work through 50 screens of varying complexity, but watch out for the most unhelpful workmates you ever came across. Remember, you are working in a factory where nothing is quite what it seems! A unique animated loading screen with perfected collision detection plus detailed and colourful graphics has made Technician Ted one of 1985's top games. Clock in with Ted now. For the 48K Spectrum and Spectrum+, £5.95. For the Amstrad CPC 464, £7.95.

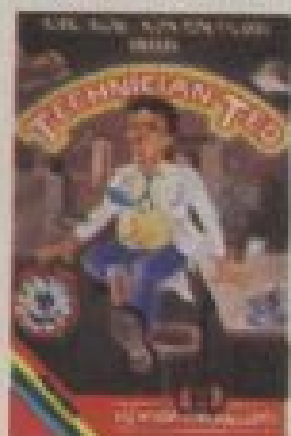

HEWSON CONSULTANTS

568 Milton Trading Estate, Milton, Abingdon, Oxon. OX14 4RX



AVALON - The 3D Adventure Movie

Can you get your astral projection Maroc past the Gate House Level, through the Mines of Madness, and onwards to meet the Lord of Chaos himself? Astounding 3D graphics over 223 rooms, 27 spells and over 100 animated characters make this the adventure game of the decade. Can you master it sooner? For the 48K Spectrum and Spectrum+, £7.95

... 7 busy characters, 10 lost chords, 12 hours, 48 Traffic Wardens,
95 London Tube Stations, 126,720 square feet of London,
7 million Londoners ... 943 action filled screens.

PAUL MCCARTNEY'S

*Give my
regards
to*

BROAD STREET

When the
music stops,
the mystery
begins...



MIND GAMES

COMMODORE 64 - £7.99



© 1985



THE FUTURE OF MANKIND IS IN YOUR HANDS!

DROPZONE

It's the year 2085. Only a handful of people have survived the robot wars that rocked the Solar System. In a final desperate bid for survival a Tacheon propelled star cruiser has been developed on Earth to transport survivors to new star system. But the cruiser relies on rare Ionian crystals for its power; crystals which are only abundant on Jupiter's second moon Io. A moonbase established on Io is under constant attack by aliens from Jupiter. It is your mission to escort the men and their precious crystals safely from the surface of Io to the Dropzone where the landing pad is located. You are equipped with the latest pulse-laser

back-pack system which will make you invisible and indestructible for short periods of time. You must succeed, the future of the human race depends on you alone!

4

ATARI



Super smooth scrolling screen
High resolution graphics
Nine different alien attackers
Scrolling high speed scanning viewer
Exploding volcanoes
Ultra fast action
Cassette £9.95
Disk £14.95



U.S. GOLD Ltd., Unit 10, The Parkway Industrial Centre, Heneage Street, Birmingham B7 4LY.
Telephone: 021-359-3020. Telex: 337268.

CAULDRON

COMPETITION

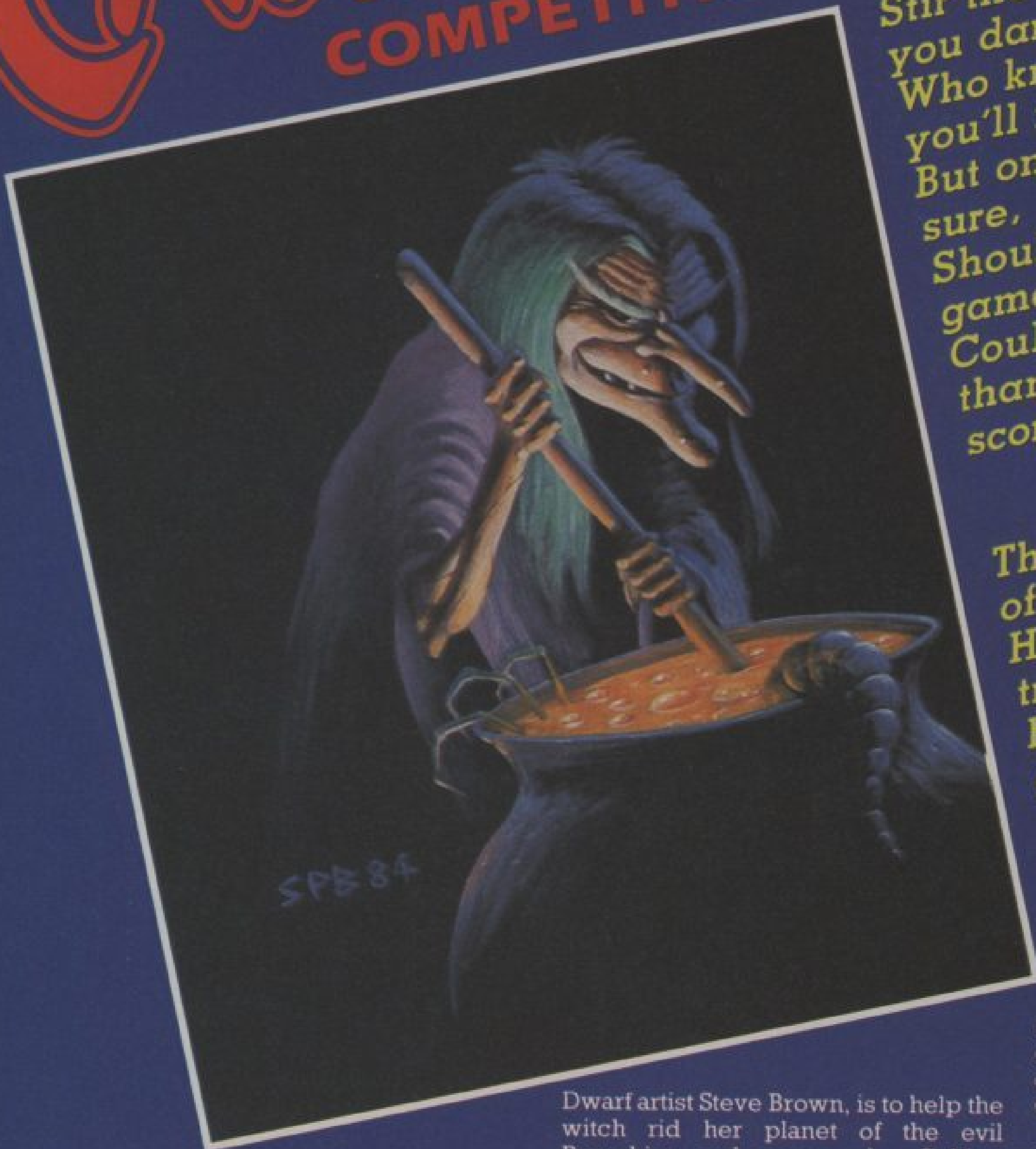

Stir the Cauldron if
you dare,
Who knows what
you'll find in there!
But one thing is for
sure,
Should you play the
game your reward
Could be a lot more
than just a high
score!

The mighty wizards
of C&VG
Have a great
treasure in store
For the first
gamester to crack
The Mystery of the
Witch's cauldron.
So hurry up and get
your skates on...

OK, so our verse writing isn't up to much! But we have got a pretty neat prize on offer for the first person to complete Palace Software's latest and greatest game, called *Cauldron*.

Together with **Palace Software, Computer & Video Games** is proud to announce the greatest **Golden Broomstick Competition!**

Yes, the first person to complete *Cauldron* and contact *Computer & Video Games* with the proof of their success will soon be the proud owner of the very same Golden Broomstick which is the object of the witch's quest in the game.

We revealed exclusive information about this great new game for the Commodore 64 and Spectrum last issue. The basic idea of the game, programmed by Richard "Evil Dead" Leinfellner and designed by White

Dwarf artist Steve Brown, is to help the witch rid her planet of the evil Pumpkins and rescue the Golden Broomstick.

The graphics are simply amazing — we can guarantee that you've not seen anything like them on the 64! Our screen shots just don't do the game justice.

The action takes place on, around and within a planet — a self-contained "world" packed with nasties and hazards. Your witch can actually fly around her planet — crossing oceans, forests and islands before venturing beneath the surface to do battle with the Pumpkins.

Cauldron really is a mega-arcade Adventure — not to be missed by adventurers and zappers alike.

To win the mighty Golden Broomstick, all you have to do is get a copy of the game — complete it and bash out a map of the game. The first person to get us a map — and answer

the tie-breaker question below correctly — will be the proud owner of the very special Palace Software Golden Broomstick!

Cauldron will be released for the Spectrum and Commodore 64 in early April and retails at £7.99.

Don't miss out on this extremely exclusive prize. Rush out and grab a copy of *Cauldron* now. You know it makes sense . . .

**C&VG/PALACE SOFTWARE
CAULDRON COMPETITION**
(Please attach this coupon to your entry)

Name.....

Address

.....

.....

Tie-breaker quiz:

What is the name of the Russian witch who has a house built on stilts made out of chicken-legs?

.....

Link to Giant Mainframes and network to thousands of Micro users via your 'phone with free Modems and Comms software in the British Telecom Modem competition.

British Telecom is offering 1000 free gift packs to plug direct into your home 'phone line.

British
TELECOM

MODEM COMPETITION

1000 FREE MODEMS

500 for Spectrum/Spectrum +
350 for BBC Model B
150 for Commodore 64

And if you haven't got a square-type BT phone socket, British Telecom will arrange to alter your installation at no charge!

HOW TO ENTER

(Monday 22nd April to Sunday 5th May 6pm to midnight)

For the 5 questions 'phone

01-627 3000 or
021-449 9944 or
031-225 8999

To get the Tiebreaker Sentence 'phone

01-627 1199 or
0532 455030 or
0632 324444

Complete the entry form using your skill and judgement, and send it off in the next post.

RULES OF THE BRITISH TELECOM MODEM COMPETITION

- 1) The dial-in is available from 6pm Monday 22nd April to midnight Sunday 5th May 1985, when the competition closes.
- 2) Entries must be postmarked the next working day after the questions and tiebreaker were obtained.
- 3) Entries can only be made on the official entry forms and become the property of British Telecommunications plc.
- 4) The competition is open only to residents of the United Kingdom over the age of 18 years. Employees of the Network Marketing Unit of British Telecommunications plc and PARKER REDMILE LTD. and their dependants are excluded. Only one winning entry per household.
- 5) Entries not reaching the competition address before midnight on Thursday 9th May 1985 will not be considered.
- 6) A list of winners will be provided at the competition address. Please send an SAE if you wish to receive it.
- 7) The winners will be picked as follows from entries received on time and properly completed -
The entries for each type of prize pack with all correct answers to the 5 questions and with the tiebreaker sentences judged most apt and humorous by the competition organisers will be chosen, subject to the stock of appropriate prize packs.
- 8) The decision of the competition organisers is final and no correspondence will be entered into. Winners will be notified automatically.
- 9) British Telecommunications plc offers winners requesting BT 'phone socket conversion on entry forms to waive the charge normally made for such work.
- 10) Details of how to get on Prestel/Micronet 800/Telecom Gold will be sent to winners. Subscriptions not included in prize.

OFFICIAL ENTRY FORM

A. Your answers:

Q 1
Q 2
Q 3
Q 4
Q 5

B. Tiebreaker Sentence complete (25 words or less in total):

"....."
.....

C. If I win, I would like the prize pack for the

- SPECTRUM/SPECTRUM +
 BBC MODEL B (Tick Choice)
 COMMODORE 64

D. My home telephone line (* Delete as appropriate)

- (a) already has a square-type BT 'phone socket * or
(b) would need converting to square-type BT 'phone socket *

If (b), the person renting the line from British Telecom must fill in this declaration -
If this is a winning entry, I agree to ask British Telecom to convert my line to square-type BT 'phone socket at a convenient date before 1st July 1985. My line is on Residential rental, is not a coinbox and is not shared service. I understand British Telecom will not charge for doing the work.

Name (Block Capitals)

Telephone number

Signature

Date 1985

E. I have read the rules of the British Telecom Modem competition and agree to abide by them. I am over 18 years old.

Signature of entrant

Date 1985

Name (Block Capitals)

Address

POST IMMEDIATELY TO:-
British Telecom Modem Competition

PO BOX 73
MITCHAM
SURREY
CR4 2XU

(Postage stamp required)

WINNERS WILL BE NOTIFIED AUTOMATICALLY

On an archaeological expedition in North Africa you were separated from the rest of your party by a huge sand storm. After several days of stumbling through the desert on the point of dying of thirst, you found a small oasis and, after drinking as much as you could, you slumped to the ground in a deep sleep.

The dust cloud had cleared when you woke and you are now facing three enormous pyramids. These pyramids are, as you have recognized from your training, the lost Pyramids of Aaron. No one has seen them for over four thousand years and legends circulate through the whole of North Africa that one of these three pyramids contains the Aaron diamond, a perfect gem the size of a child's head.

Fame and fortune will be yours if you can search each of the pyramids in turn and recover the diamond.

Unfortunately, the pyramids contain many devious traps and you will have to use your ingenuity to survive.

Full instructions are included in the listing.

PYRAMIDS OF AARON

RUNS ON A 48K SPECTRUM

BY RICHARD EVANS

```

10 PAPER 0: INK 0: BORDER 0: C
LS
15 PRINT AT 21,0: INK 7: "WELCO
ME TO THE PYRAMIDS OF AARON"
20 FOR f=-80 TO 80: PLOT 150,1
75: DRAW f,-150+(20 AND f=-80):
PLOT 40,150: DRAW f/2,-65+(10 AN
D f=-80): PLOT 200,160: DRAW f/3
,-50+(15 AND f=-80): LET f=f+(30
AND f=-80): NEXT f
25 PRINT AT 21,0: INK 6: "A GAM
E OF SKILL, DEXTERITY AND..."
30 RESTORE 31: FOR f=15 TO 0 S
T M P-1: CHRM 15,150,f: CIRCLE 5
250,150,f: NEXT f: FOR f=1 TO 5:
250,50,0,4: PLOT 5,5: DRAW 0,4
: NEXT f
31 DATA 220,120,35,0,0,120,17
0,00,120,55,0,70,40,30,-20,0,05,
10,10
32 GO SUB 8000
33 PRINT AT 21,0: INK 5: "INGEN
UITY: PRESS ANY KEY TO BEGIN"
40 FOR f=0 TO 8: PRINT INK 6:
0000: AT f,0: PAPER 5: NEXT f
50 FOR f=7 TO 0: PRINT AT f,0: D
6000: OVER 1: NEXT f: FOR f=
6000: PRINT OVER 1: AT f,0: INK
6000: NEXT f
70 INPUT "PAUSE 1
8000: PAUSE 1: INK 7
80 FOR f=18 TO 14 STEP -1: PRI
8000: NEXT f
90 PAUSE 100
95 PRINT AT 21,0: "DO YOU REQUI
RE INSTRUCTIONS(Y/N)?"
100 INKEY#="c" OR INKEY#="Y"
THEN GO SUB 9000: GO TO 80
110 INKEY#="n" AND INKEY#<>
"n" THEN GO TO 97
120 BRIGHT 0: BORDER 4: PAPER 4
130 INK 0: CLS
140 LET X=1: LET Y=0
150 LET U$="DEADDEAD": LET L
160: LET level=1: LET level=1: LET S
170
180 LET C=0
190 LET T=0
200 LET P=0
210 LET V=0
220 CLS: GO SUB 8000+level*10
230 PRINT AT X,4: "D": RESTORE 0
240 FOR f=1 TO 7: READ a,b: BEEP
250,5: NEXT f
260 DATA 1,0,2,2,1,0,2,-3,2,-5,
4,-1,1,3
270 LET time=time-dif: LET n#=I
NKEY#
280 IF time<=0 THEN GO TO 5000:
GO TO 30
290 PRINT #0: AT 0,0: "TIME LEFT:
PRINT time, "SCORE: ",SC: AT 1,10:
PRINT: "($ ( TO ))": LET C#=(#(
10)+C#( TO 0)

```



AMIDS ARON



```
110 PRINT AT X,Y;" "; LET X1=X:
LET Y1=Y: LET Y=Y+(J#="8")-(J#="
9") AND Y>0: IF ATTR (X,Y)=8 TH
EN LET X=X1: LET Y=Y1
111 IF Y=32 OR (Y=31 AND J#="8"
AND ATTR (X,Y)=32) THEN LET Lev
=lev+1: LET sc=INT (sc+(lev+tim
e)): LET (lev=lev+1: GO TO 80
114 IF ATTR (X+1,Y)<>8 THEN GO
TO 120
115 IF J#="9" THEN GO SUB 5000
116 IF J#="4" THEN GO SUB 5100
120 LET a=ATTR (X,Y): LET a1=AT
TR (X+1,Y)
130 IF a<>32 THEN GO SUB 2000
131 IF a1=200 THEN GO TO 5000
140 PRINT AT X,Y;"D" AND P); ("
R" AND NOT P): LET P=NOT P
145 IF fall>10 THEN GO TO 5000
150 IF a1=32 THEN LET fall=fall
+1: BEEP .01,20: PRINT AT X,Y;"
": LET X=X+1: GO TO 100
160 BEEP .01,10: LET fall=0: GO
TO 100
2000 IF a=8 THEN LET a1=8: LET X
=X1: LET Y=Y1: RETURN
2001 IF a=200 THEN GO TO 5000
2002 IF a=22 THEN GO TO 5000
2100 PRINT a: STOP
5000 BRIGHT 1: FOR f=1 TO 20: BE
EP .03,0: PRINT AT X,Y;"D": BEEP
.03,4: PRINT AT X,Y;"E": BEEP
.03,7: PRINT AT X,Y;"A": BEEP .03
,10: PRINT AT X,Y;"F": NEXT f: B
RIGHT 0
5010 PRINT AT X,Y;" ": FOR f=30
TO 10 STEP -1: BEEP .01,f: NEXT
f
5020 LET li=li-1: IF li=0 THEN G
O TO 5040
5030 FOR f=0 TO 10 STEP .3: BEEP
.01,f: NEXT f: GO TO 80
5040 FOR f=0 TO 4 STEP .1: BORDE
R f: BEEP .03,-f+10: NEXT f
5050 CLS: LET b$="" THE PYRAMID
HAS BEATEN YOU.
5060 FOR f=1 TO 100: BEEP .01,AN
D#10+30: LET g=INT (RAND*32)+1: P
RINT AT 10,g-1: INVERSE 1:b$(g):
NEXT f
5070 PRINT AT 10,0: INVERSE 1:b$
5080 PRINT AT 12,2: INVERSE 1)"Y
OU SCORED ";sc;" POINTS"
5090 PRINT AT 21,0:"PRESS ANY KE
Y TO START AGAIN...": PAUSE 1:
PAUSE 0: GO TO 80
5095 LET Y4=1: LET b$="F": GO TO
5300
5100 LET Y4=-1: LET b$="E": GO T
O 5300
5300 LET fall=0: PRINT AT X,Y;"D
": BEEP .01,20: RESTORE 5390: FO
R J=1 TO 5: LET time=time-.5: PR
INT AT X,Y;" ": LET X1=X: LET Y1
=Y: READ XX,YY: IF X+XX<0 OR Y+Y
Y>31 OR Y+YY<0 THEN RETURN
5301 IF ATTR (X+XX,Y+YY)<>32 THE
N LET X=X+XX: LET Y=Y+YY: RETURN
5310 LET X=X+XX: LET Y=Y+YY: PRI
NT AT X,Y;b$
5320 BEEP .01,J+J: NEXT J: RETUR
N
5390 DATA -1,0,-1,0,-1,94,0,94,1
,94,1,0,1,0
5400 RESTORE 8001: FOR f=0 TO 63
: READ a: POKE USR "a"+f,a: NEXT
f: RETURN
8001 DATA BIN 11000,a,BIN 100100
00,BIN 1111100,BIN 11011,BIN 110
00,BIN 100100,BIN 1000010
8002 DATA 255,170,85,170,85,170,
85,255
8003 DATA BIN 100,BIN 1001010,BI
N 1101001,BIN 1010001,BIN 100000
1,BIN 10010011,BIN 10011010,BIN
10101010
8004 DATA BIN 11000,a,BIN 1001,5
IN 111110,BIN 11011000,BIN 11000
,BIN 100100,BIN 1000010
```

```

8005 DATA BIN 1011000,BIN 101100
8006 DATA BIN 101000,BIN 11110,BIN 11110
8007 DATA BIN 10001000,BIN 100,BBIN 10
8008 DATA BIN 11010,a,BIN 10100,
8009 DATA BIN 10011110,BIN 100
8010 DATA 0,0,0,BIN 11000,a,0,0,
0
8008 DATA BIN 10000,BIN 101000,B
IN 1100101,BIN 10000110,BIN 1101
000,BIN 10000,a,a
9000 LET time=55: LET X=1: FOR f
=2 TO 19 STEP 2: FOR n=0 TO 1: P
RINT AT n+f,0: INK 0: PAPER 1:"B
BBBBBBBBBBBBBBBBBBBB" ( TO (f/2+7): AT
n+f,26-f/2:"BBBBBBBBBBBBBBBBBBBB": NE
XT n: NEXT f
9001 FOR f=0 TO 31 STEP 3: PRINT
PAPER 2: INK 6: AT 0,f:"C": NEXT
f
9002 PRINT AT 20,0: INK 6: PAPER
2:"CCCCCCCCCCCCCCCCCCCCCCCCCCCCCCCC
CCCC"
9009 RETURN
9010 LET time=58: LET X=1: FOR f
=2 TO 21: PRINT AT f,0: PAPER 1:
INK 0:"BBBBBBBBBBBBBBBBBBBBBBBBBBBB
BBBBBBBB": NEXT f
9011 LET X2=9: LET Y2=0: LET Y4=
1: FOR n=1 TO 10: RESTORE 8390:
FOR f=1 TO 4: READ XX,Y4: LET X2
=X2+XX: LET Y2=Y2+Y4: PRINT AT X
,Y2:"": AT X2+1,Y2:"": AT X2+
Y2+INT (RND*2): INK 6: PAPER 2
:"C" AND f=2: NEXT f: LET X2=X
2+4: LET Y2=Y2+1: NEXT n
9012 FOR f=1 TO 7: PRINT AT f,0:
"": NEXT f
9013 PRINT AT 17,30:"": AT 18,0
9:
9019 RETURN
9020 LET time=110: LET X=19: FOR
f=10 TO 20 STEP 5: PRINT AT f,2
: INK 0: PAPER 1:"BBBBBBBBBBBBBBBBBB
BBBBBBBBBBBBBBBB": NEXT f
9021 FOR f=3 TO 21: PRINT AT f,3
1: INK 0: PAPER 1:"B": NEXT f
9022 FOR f=1 TO 7: PRINT AT (RND
*14)+7,INT (RND*17)+5: INK 6: PA
PER 2:"C": NEXT f
9023 PRINT AT 21,0: INK 6: PAPER
2:"CCCCCCCCCCCCCCCCCCCCCCCCCCCCCCCC
CCCC"
9024 PRINT AT 20,0: INK 0: PAPER
1:"B": AT 7,9:"BBB": AT 4,21:"BBB
BBBBBBBB": AT 5,10:"BBBBBBBBBBBB": AT
12,0:"B": AT 17,30:"B"
9029 RETURN
9030 LET time=97: LET X=0: PRINT
AT 1,0: INK 0: PAPER 1:"BBBBBBB
BBBBBBBBBBBBBBBBBBBBBBBBBBBB": FOR
f=2 TO 18: PRINT AT f,0: INK 6:
PAPER 2:"CCCCCCCCCCCCCCCCCCCCCCCCCCCC
CCCC": NEXT f: FOR f=19 TO
21: PRINT AT f,0: INK 0: PAPER 1
:"BBBBBBBBBBBBBBBBBBBBBBBBBBBBBBBBBB
BB": NEXT f
9031 FOR f=1 TO 10: PRINT AT f,1
0+f:"": NEXT f: FOR f=11 TO 17
: PRINT AT f,36-f:"": NEXT f:
FOR f=17 TO 10 STEP -1: PRINT AT
f,f:"": NEXT f: FOR f=10 TO 1
8: PRINT AT f,9:"": NEXT f
9033 PRINT AT 19,9:"":
"": AT 20,22:""
9034 FOR f=17 TO 19: PRINT AT f
: NEXT f: PRINT AT 10,20
: PRINT INK 6: PAPER 2: AT
20,25:"CC": AT 19,26:"CC": AT 20,20
0000"
9035 PRINT INK 0: PAPER 1: AT 8,0
0:"B": AT 10,26:"B": AT 10,17:"BBB
B"
9036 FOR f=18 TO 11 STEP -1: PAPER
1: AT f,f-1: INK 0: PAPER 1:"B": A
T f-2,f:"B": NEXT f

```

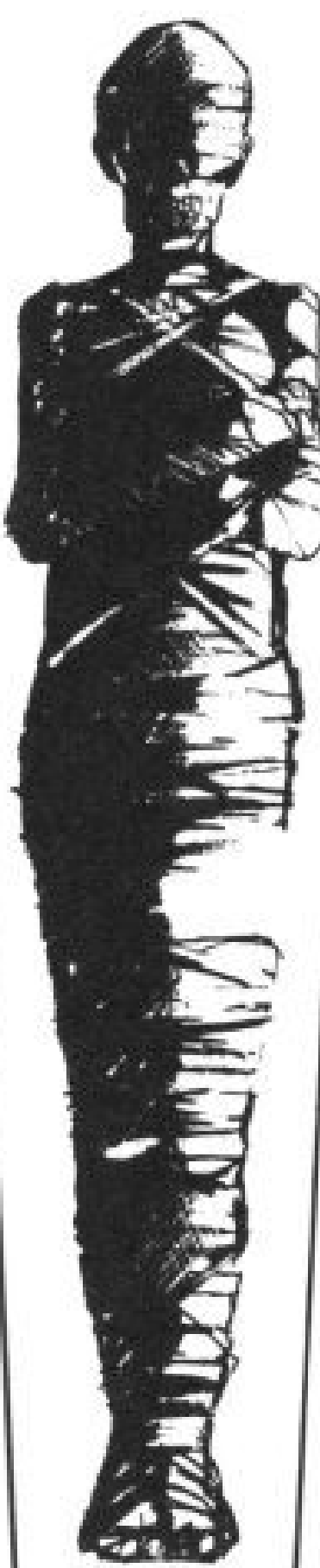

```

9040 RETURN
9040 LET time=105: LET X=19: FOR
f=0 TO 20: PRINT AT f,0: INK 0:
PAPER 1:"BBBBBBBBBBBBBBBBBBBBBBBB
BBBBBBBB": AT f,31:"B": PRINT AT f,5:"
"
9041 FOR f=17 TO 3 STEP -5: PRIN
T AT f,8: INK 0: PAPER 1:"BB": AT
f+3,5:"BB": NEXT f
9042 FOR f=4 TO 17: PRINT AT f,1
4: INK 6: PAPER 2:"CCCCCCCC": NE
XT f
9043 FOR f=2 TO 10: PRINT AT f,1
2:"": NEXT f: PRINT AT f,1
2:"": AT 12,12: INK 0: PAPER 1:"BB
BB"
9044 FOR f=2 TO 8: PRINT AT f+9,1
7-8B (5,5-f): NEXT f: PRIN
T AT 18,15:"": AT 19,15:""
9044 FOR f=20 TO 10 STEP -1: PAPER
2: NEXT f: INK 6: PAPER 1:"BB
B"
9047 PRINT AT 21,0: INK 6: PAPER
2:"CCCCCCCCCCCCCCCCCCCCCCCCCCCCCCCC
CCCC"
9048 PRINT AT 0,31:"": AT 1,10:"
": AT 19,0:"": AT 1,10:""
"": AT 3,1:"": AT 4,1:""
"": AT 5,0: AT 2,1:"": AT 1,1
1: AT 5,5:"B": AT 3,5:"B": PAPER
2
9049 RETURN
9050 LET time=43: LET X=0: FOR f
=0 TO 28 STEP 2: LET f=f+(RND)*5
AND f<>0: FOR n=f/2+4 TO 28 ST
EP 4: PRINT INK 0: PAPER 1: AT n,
f:"B": NEXT n: NEXT f
9051 PRINT AT 19,28: PAPER 1: IN
K 0:"BBBBB"
9052 PRINT AT 20,0: INK 6: PAPER
2:"CCCCCCCCCCCCCCCCCCCCCCCCCCCCCCCC
CCCC"
9059 RETURN
9060 LET time=87: LET X=17: FOR
f=20 TO 2 STEP -1: PRINT AT 23-f
: INK 0: PAPER 1:"B": NEXT f
9061 FOR f=1 TO 18: PRINT INK 6:
PAPER 2: AT f,28-f:"CCCCCCCCCCCCCCCC
CCCC": NEXT f
9063 FOR f=15 TO 18: PRINT AT f
: NEXT f: PRINT AT 13,2
4:"": AT 14,24:"": AT 18,14:""
"": AT 17,14:"": AT 16,14:""
"": AT 15,14:""
9064 PRINT "": AT f,17:"": NEX
T f
9064 PRINT AT 10,15: INK 0: PAPE
R 1:"B": AT 19,0:"B": AT 20,10:"BB
B"
9065 PAPER 4:"BBB": "BB": AT 17,21:"B"
9066 PRINT AT 21,0: INK 6: PAPER
2:"CCCCCCCCCCCCCCCCCCCCCCCCCCCCCCCC
CCCC"
9069 RETURN
9070 LET time=150: FOR f=11 TO 1
STEP 6: PRINT INK 6: PAPER 2: A
T f,0:"CC": AT f+3,2:"CC": NEXT f
9071 PRINT AT 21,0: INK 6: PAPER
2:"CCCCCCCCCCCCCCCCCCCCCCCCCCCCCCCC
CCCC"
9072 FOR f=3 TO 31 STEP 3: PRINT
AT 20,f: INK 0: PAPER 1:"B": LE
T f=f+INT (RND*3): NEXT f
9073 FOR f=1 TO 21: PRINT AT f,3
1: INK 0: PAPER 1:"B": NEXT f
9074 FOR f=4 TO 17 STEP 4: PRINT
INK 0: PAPER 1: AT f,27:"B": AT f
+2,30:"B": NEXT f
9075 PRINT AT 1,3: INK 0: PAPER
1:"BBBBBBBBBB": AT 1,16:"BBBBBBBBBB
BB"

```

SPRING INTO ACTION

ON Gribbly's Day Out



Welcome to Blabgor, home of Gribbly Gribbly, one of a race of peaceful creatures who have developed their brain to such an extent that they can move around entirely by thought power alone, their intelligence – or Psi – being stored in their Psi banks which must be topped up regularly.

The hills around them are infested with more primitive creatures who are out to attack and carry off the

younger Blabgorians, known as Gribblets.

In this exotic world the Gribblets lead a carefree life and can be found playing behind rocks, over the lakes and on mystical floating islands. Can you herd the threatened Gribblets to the safety of the cave? Trying to stop you is Seoni, a wayward Blabgorian, who is now imprisoned in the skies behind the energy web. But for how long?

Played over 16 colourful and titled

screens, each 30 times the on screen display this highly original game incorporates detailed graphics, smooth all direction multispeed scrolling, stunning sound effects and is controlled entirely by joystick for quick response. You'll see how well you're doing by Gribbly's expressions – too many frowns means that you need more practice! Bounce out and get your copy now!

Only £7.95
For the Commodore 64



3D Lunattack

Flying your Luna Hover Fighter, try and penetrate the 3 successive Seiddab zones to destroy their command base.

Up to the minute status reports on your fighter's condition and the Seiddab defences make Lunattack the space adventure of the decade.

May the power be with you!

For the Commodore 64

£7.95



HEWSON CONSULTANTS

568 Milton Trading Estate, Milton, Abingdon, Oxon. OX14 4RX



Heathrow International ATC

Use your detailed radar screen to guide incoming aircraft – including Concorde – safely down from holding stacks to the runway at Heathrow. Emergencies such as unknown aircraft intrusion and radio failure call for ice-cool concentration.

For the Commodore 64 **£7.95**

48K SINCLAIR ZX SPECTRUM

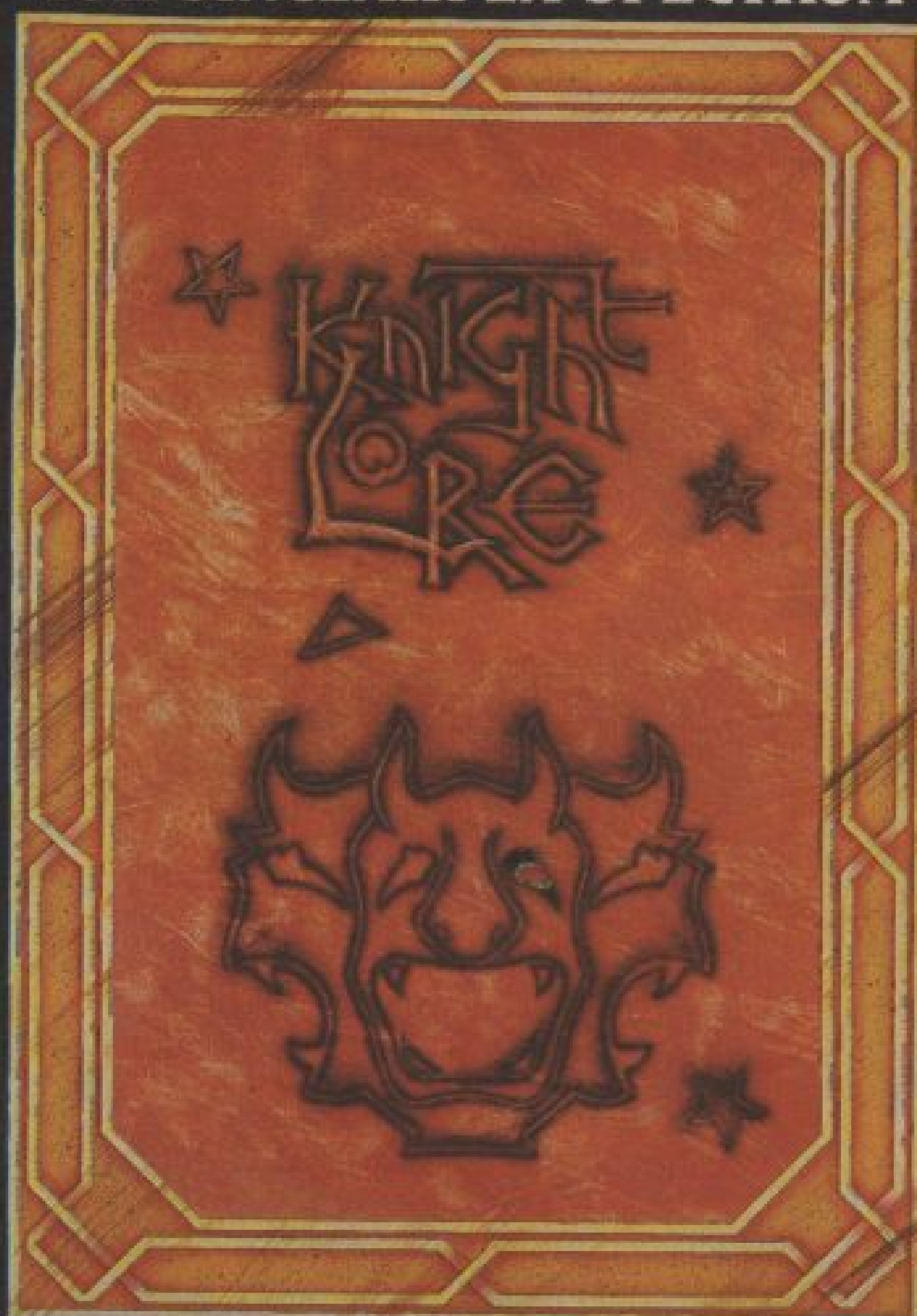

BBC MODEL B 1.2 OS

48K SINCLAIR ZX SPECTRUM

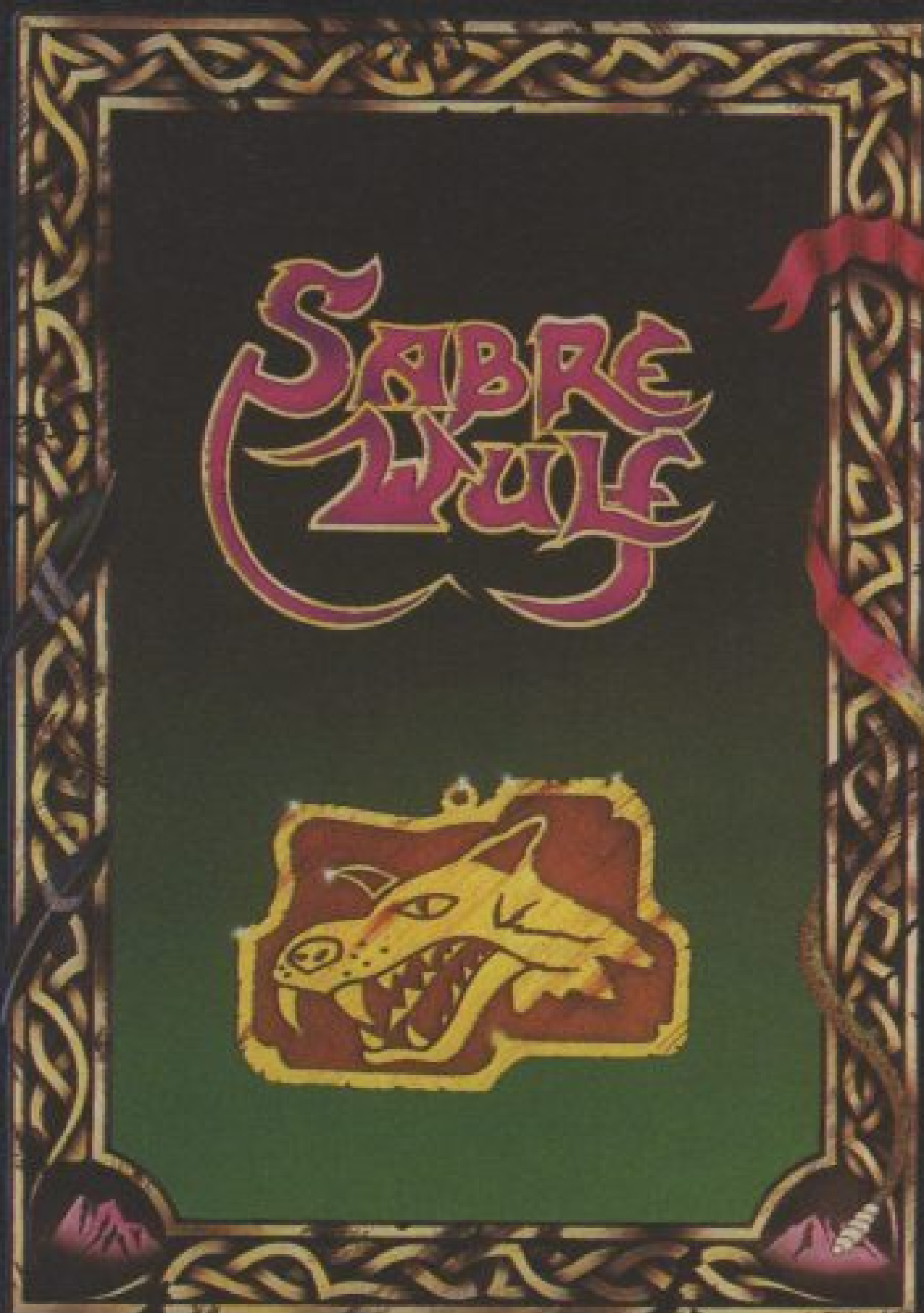

48K SINCLAIR ZX SPECTRUM

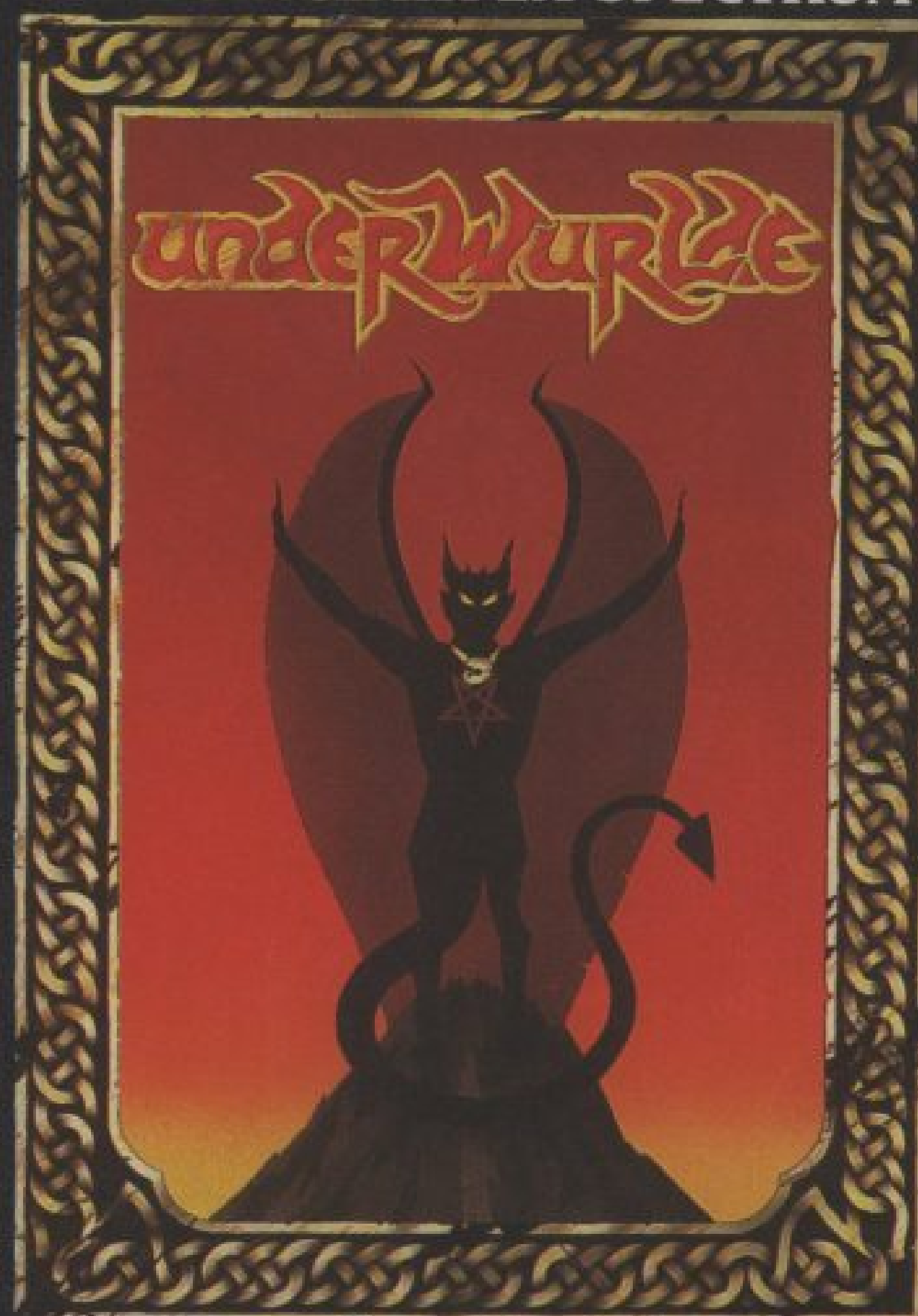

COMMODORE 64

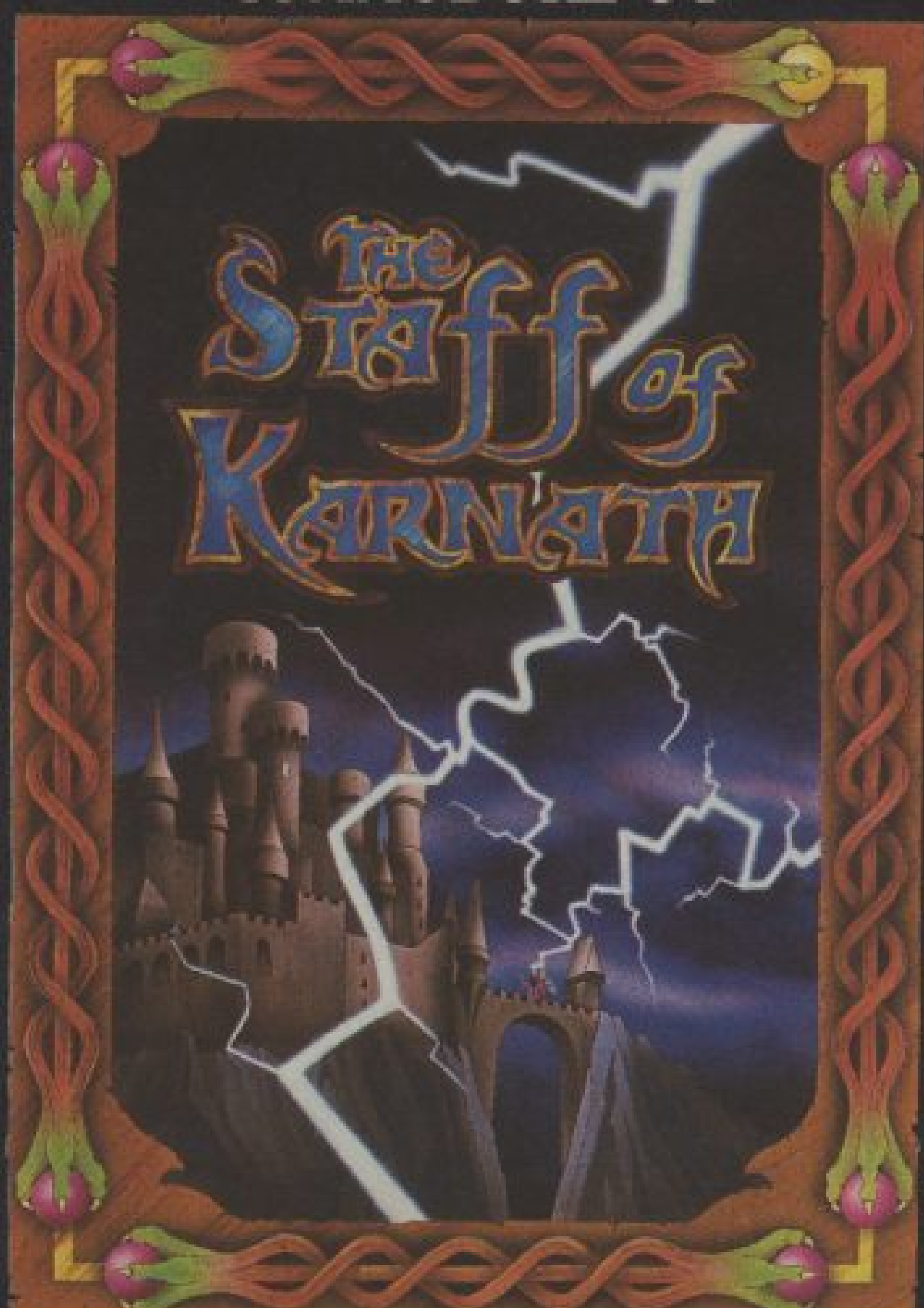

"KNIGHTLORE", "UNDERWURLDE", "SABRE WULF", and "STAFF OF KARNATH" recommended retail price £9.95 inc VAT. Available from W.H.SMITH, BOOTS, J.MENZIES, WOOLWORTHS and all good software retail outlets. Also available from ULTIMATE PLAY THE GAME, The Green, Ashby-de-la-Zouch, Leicestershire LE6 5JU (P&P are included) Tel: 0530 411485



SEGA[®]

THE ARCADE WINNERS

released
NOW

SPY HUNTER

THE OFFICIAL HOME VERSION OF BALLY MIDWAY'S ARCADE HIT

- You control the turbo charged race car/hydro spy boat.
- You control a deadly arsenal of missiles, machine guns, oil slicks and smoke screens.
- Sophisticated spy-challenging graphics.

U.S. Gold is stocked by
 John Menzies, WILDINGS
WOOLWORTH, WHSMITH,
Rumbelows
and Spectrum Shops

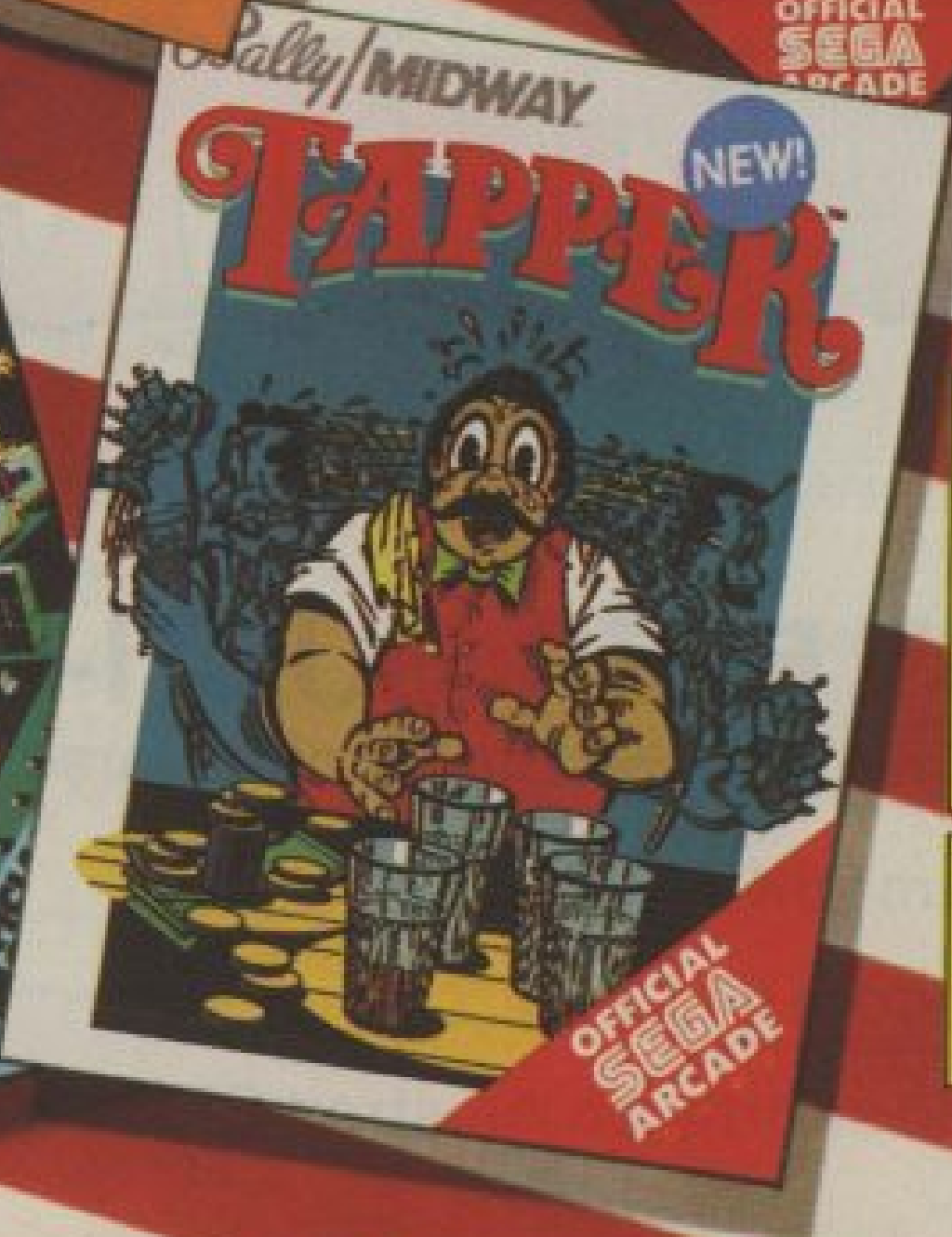
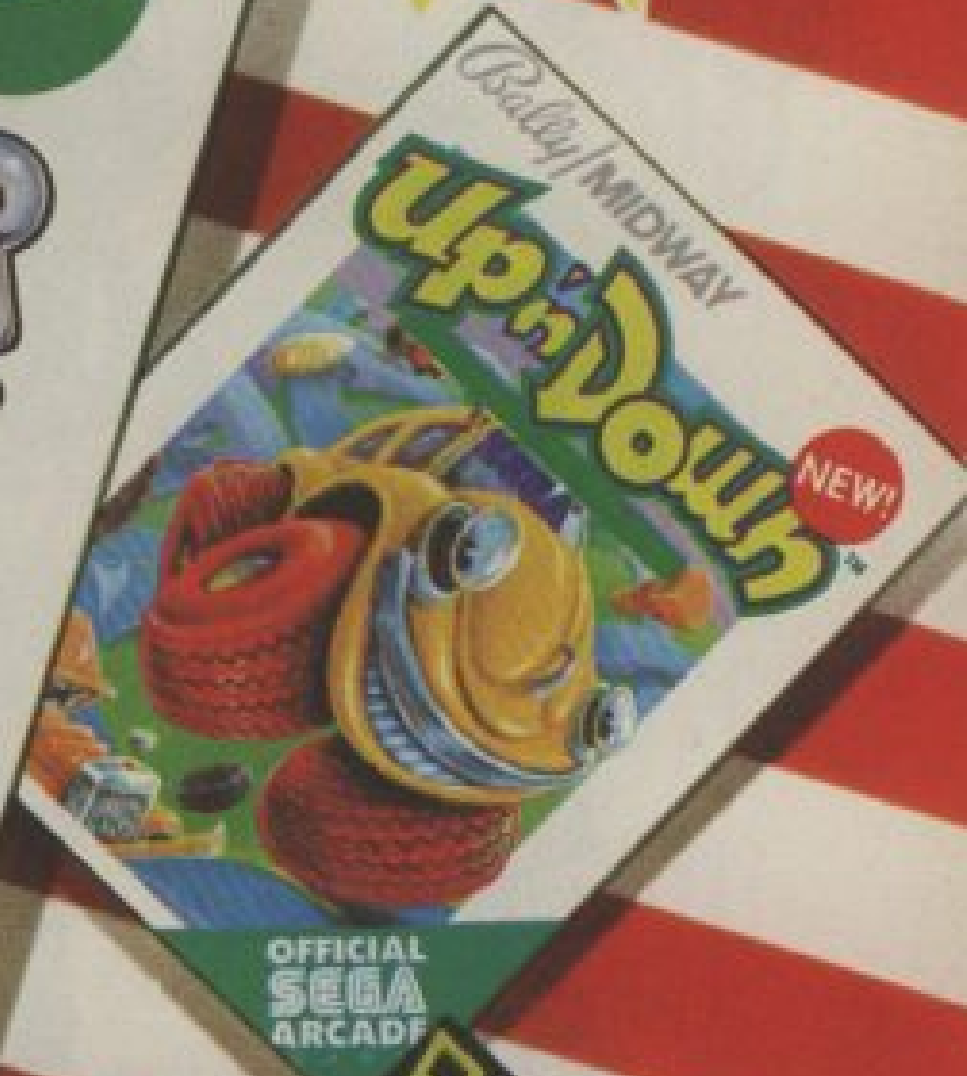

COMMODORE
CASSETTE
9.95
DISK
12.95

SPECTRUM
CASSETTE
7.95



Exclusive manufacturers for
SEGA and Bally MIDWAY.

For release schedule and trade details contact:
Centre Soft, Unit 10, The Parkway Industrial Centre, Heneage Street, Birmingham B7 4LY. Telephone: 021-359 3020. Telex: 337268.

Meet the Gang!

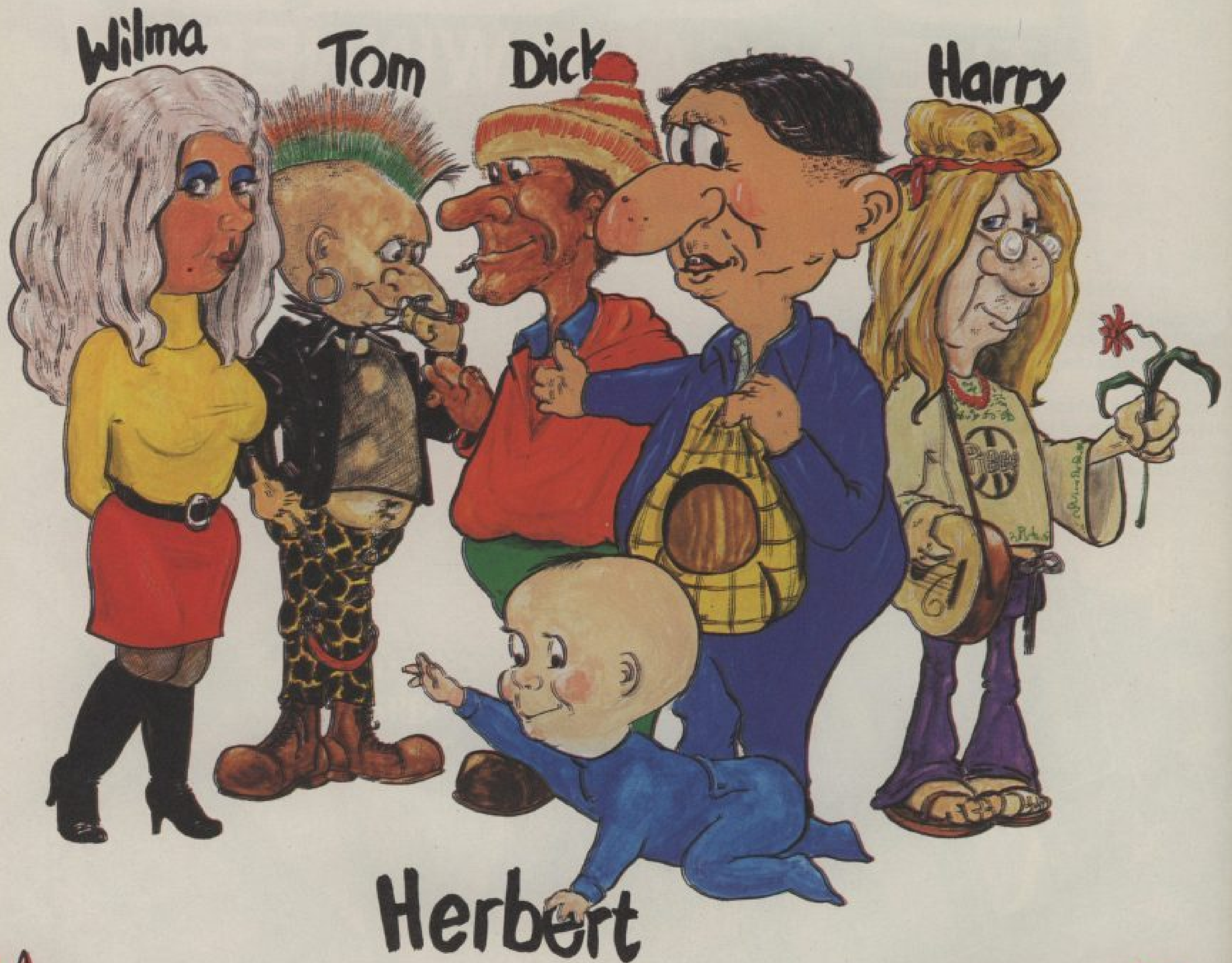

“**Everyone's a Wally**”

1ST EVER MULTI-ROLE ARCADE ADVENTURE

Includes Hit Single on reverse "Everyone's A Wally" performed by Mike Berry

Spectrum 48K £9.95

Commodore 64 £9.95

Available shortly on Amstrad CPC 464

MIKRO-GEN

44 The Broadway, Bracknell, Berks. 0344 427317



RUNS ON VIC 20 IN 3.5K

BY SHAUN MULLINS

```

30 REM DEFENDER
31 REM BY SHAUN MULLINS
32 REM UNEXPANDED VIC
33 REM INSTRUCTIONS
34 GOSUB1030
35 BA=4*(PEEK<36866>AND128)+64*(PEEK<368
36 >AND128)
37 POKE36879,47
38 POKE36867,44
39 PRINT"U"
40 PRINT"U"IN THIS GAME YOU MUST"
41 PRINT"U"STOP AN ALIEN INVASION
42 "
43 PRINT"U" BY SHOOTING THEM"
44 PRINT"U" WITH YOUR LASER"
45 PRINT"U" CONTROL "-"
46 PRINT"U" LEFT=K
47 PRINT"U" RIGHT=V
48 PRINT"U" LAZERS=N
49 GOSUB1000
50 PRINT"U" THE ALIENS MOVE IN 3"
51 PRINT"U" DIRECTIONS"
52 PRINT"U" DOWN
53 "
54 PRINT"U" DIAGONALLY "
55 PRINT"U" LEFT AND RIGHT."
56 PRINT"U" THE GAME ENDS WHEN"

```

```

100 PRINT"U" ONE ALIEN LANDS. "
101 PRINT"U" YOUR SCORE IS SHOWN"
102 PRINT"U" GOOD LUCK "
103 PRINT"U" INPUT DIFFICULTY"
104 PRINT"U" 1-HARD TO 9-EASY"
105 GETA#:IFVAL(A#)<1ORVAL(A#)>9THEN103
106 FORM=0TO200:NEXTM
107 REM GAME
108 POKE36869,255
109 PRINT"U":FORI=BA+484TOBA+505:POKEI,1
110 NEXTI:H=VAL(A#)+1:Y=BA+462
111 Y1=1:Y2=5:Y3=19 T=BA+1 R1=BA+481:L1=
112 Y R=27:O=26:F=28:C=32:P=197
113 A1=INT(RND(TI)*20+T) A2=INT(RND(TI)*
114 20+T) B1=INT(RND(TI)*3+21)
115 B2=INT(RND(TI)*3+21):POKEY,Y1:POKEY+
116 1,Y2:POKEY+2,Y3
117 L=PEEK(P):IFL<0FANDL<0RANDL<0THEN22
118 "
119 IFL=FTHEN300
120 IFL=RANDY<R1THENPOKEY,C:Y=Y+1:POKEY,
121 Y1:POKEY+1,Y2:POKEY+2,Y3:GOTO220
122 IFL=OANDY>L1THENPOKEY+2,C:Y=Y-1:POKE
123 Y,Y1:POKEY+1,Y2:POKEY+2,Y3
124 G=G+1:IFG>HTHENG=1
125 ONGGGOTO240,250,180,180,180,180,1
126 80,180,180,180

```

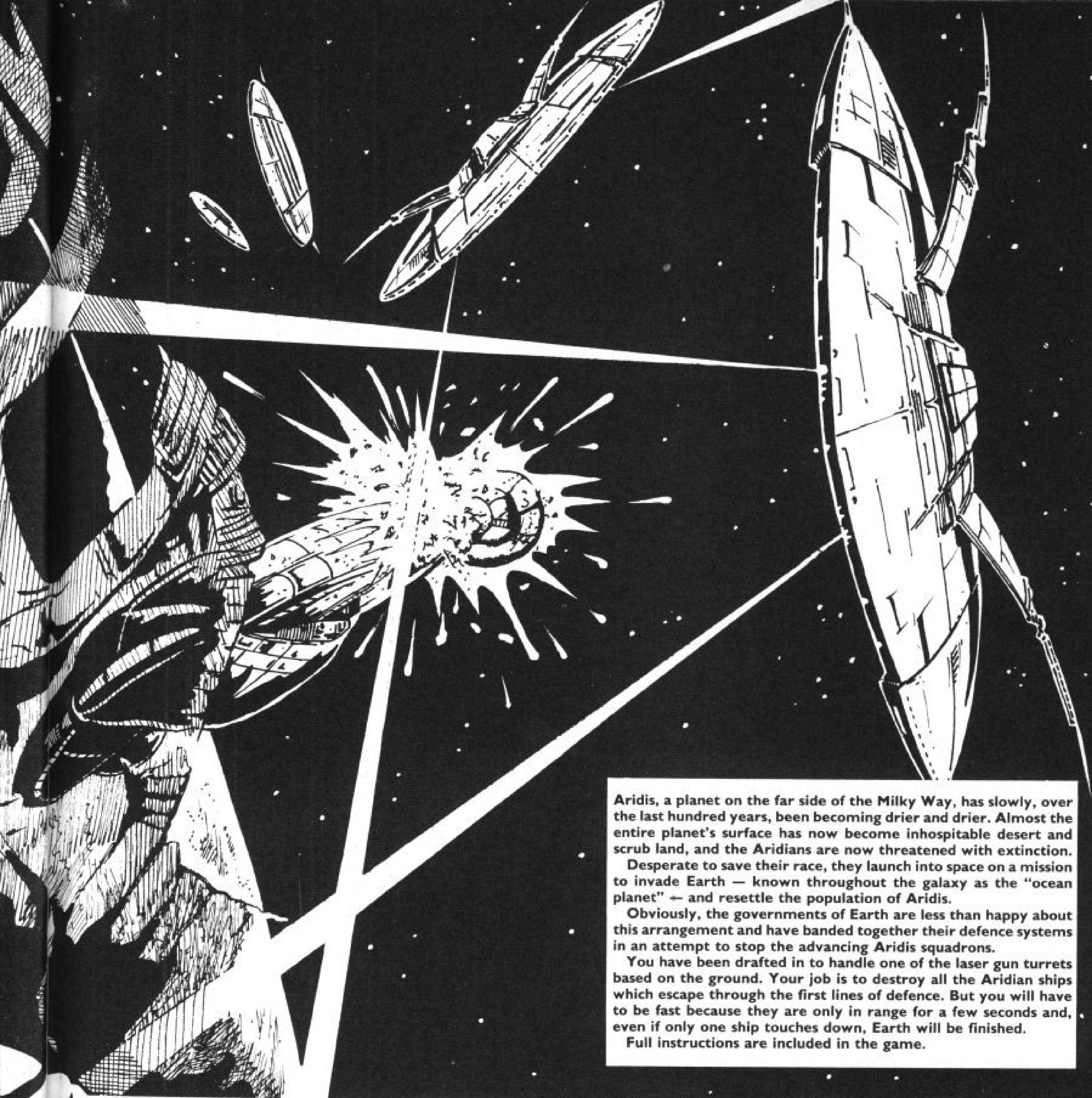

Aridis, a planet on the far side of the Milky Way, has slowly, over the last hundred years, been becoming drier and drier. Almost the entire planet's surface has now become inhospitable desert and scrub land, and the Aridians are now threatened with extinction.

Desperate to save their race, they launch into space on a mission to invade Earth — known throughout the galaxy as the "ocean planet" — and resettle the population of Aridis.

Obviously, the governments of Earth are less than happy about this arrangement and have banded together their defence systems in an attempt to stop the advancing Aridian squadrons.

You have been drafted in to handle one of the laser gun turrets based on the ground. Your job is to destroy all the Aridian ships which escape through the first lines of defence. But you will have to be fast because they are only in range for a few seconds and, even if only one ship touches down, Earth will be finished.

Full instructions are included in the game.

```

240 A=A1:B=B1:GOSUB260:A1=A:GOTO180
250 A=A2:B=B2:GOSUB260:A2=A:GOTO180
260 A=A+B:IFPEEK(A)=CORPEEK(A)=24 THENPOKE
EA-B,C:POKEA,24:RETURN
265 POKE36869,255
270 PRINT"THE ALIENS HAVE LANDED"
      H1=PEEK(366+H):POKE368
69,240
271 POKE36878,15:FORL=1TO20:FORM=220-LTO
260-LSTEP-4:POKE36878,M:NEXTM
272 FORM=160-LTO220-LSTEP4:POKE36878,M:N
EXTM:NEXTL:POKE36878,0:POKE36878,0
280 PRINT"YOU ZAPPED";S:PRINT"INVADER
S ON"
281 PRINT"SKILL LEVEL";H-1:IF S>H1 THENH
1=S
290 PRINT"HIGH SCORE =";H1:POK
E366+H,H1:IF S>H1 THENH1=S:H1=H1(S)
295 S=0:GOTO120
300 N=Y-21:FORI=MTOSTEP-22:IFPEEK(I)=CT
HENPOKEI,26:NEXT:GOTO330
310 S=S+1:POKEI,0:GOSUB350:IFI=A1 THENA1=
INT(RND(T1)*20+T):B1=INT(RND(T1)*3+21):G
OTO330
320 A2=INT(RND(T1)*20+T):B2=INT(RND(T1)*
3+21)
330 J=1:FORI=MTOJSTEP-22:POKEI,C:NEXT:G=
G+1:IFG>2 THENG=1

```

```

340 GOTO230
350 POKE36877,128:FORX=15TO0STEP-1:POKE3
6878,X
360 FORZ=1TO20:NEXTZ:NEXTX
370 POKE36877,0:POKE36878,0
380 RETURN
1000 PRINT:PRINT"HIT A KEY"
1010 GETA#:IFA#="" THEN1010
1020 PRINT"U":RETURN
1026 REM GRAPHICS
1030 DATA126,219,255,255,60,102,66,195
1040 FORA=7360TO7367:READB:POKEA,B:NEXT
1050 DATA0,0,0,0,15,15,15,15
1060 FORC=7176TO7183:READD:POKEC,D:NEXT
1070 DATA24,24,60,126,255,255,255,255
1080 FORE=7208TO7215:READF:POKEE,F:NEXT
1090 DATA0,0,0,0,240,240,240,240
1100 FORG=7320TO7327:READH:POKEG,H:NEXT
1110 DATA24,24,24,24,24,24,24,24
1120 FORI=7376TO7383:READJ:POKEI,J:NEXT
1130 DATA126,219,126,126,60,36,66,36
1140 FORK=7168TO7175:READL:POKEK,L:NEXT
1150 POKE55,255:POKE56,27
1170 FORI=7424TO7431:POKEI,0:NEXTI
1180 RETURN

```

READY:

BUG HUNTER

— WRITE TO ME AT: COMPUTER & VIDEO GAMES
PRIORITY COURT, 30-32 FARRINGTON LANE,
LONDON EC1R 3AU. OR PHONE ME
ON: 01-2516222.



Almost half of my monthly mailbag consists of letters containing cheat codes for various games. You know, those secret **POKES** that let you get straight to the hardest screen, or code words to give you unlimited lives. This month, *Bug Hunter*, Enterprises brings you a host of cheating **POKES** so, if you're stuck at level one on your favourite game, read on. We may have just the information you're looking for.

FALL GUY PROBLEM

First, though, a note about the *Fall Guy* for the Spectrum, from Elite. The turbo loader used on early copies of the game has been causing problems with many cassettes, and the game is now sold without the fast loader. If you still have an early copy and are having problems, return it to your dealer who should be able to get it replaced for you.

DISKS FOR THE 64

Paul Filmer writes from Kent in reply to an earlier letter about copying cassette-based games to disk on the 64. Paul recommends DOSOFT which costs £9.99 from 2 Oakmoor Avenue, Blackpool. I haven't tried the program myself but, if you're looking for such a program, write to the company and ensure that it will do what you want **BEFORE** you send off any money.

MICRONET MAILBOX

Next, here are some of the messages I received this month via Micronet. If you're a member, my mailbox number is 012 786 556. David Thomas says that, when playing *Match Day*, it is possible to stand with the ball just bouncing up and down on your head. It's a useful way of wasting time, he says. Hmmm!

P R Russell simply writes to tell me that he's Elite, while Leigh Hoyte says there's a bug in *Fred* for the Spectrum. Fire at a ghost while it's passing through a wall, says Leigh, and your score increases dramatically.

Gareth Clegg asks if he can write to Keith Campbell through Micronet. I

hear that Keith is in the process of getting online, Gareth, and will soon have his own mailbox number.

Maurice Poole says "On *Sherlock*, type 255 spaces and see what happens".

CODENAME CHEAT!

Now, all you potential cheaters, here goes...

Ian Farrelly says that for 255 lives on *Zalaga* for the BBC, type *LOAD "ZALAG3", then ?&301B=&FF and CALL &4522. For the equivalent on *FRAK*, *LOAD "FRAK22", ?&305B=&FF then CALL &468A.

If you have the *CBM Ghostbusters* game and want some more money, here's a name and account number which will give you \$260,500. Bray, Chris is the name, and the number is 05005211.

J G Gunning says that, for endless lives on *Motor Mania* for the 64, POKE 8646,255 and then SYS 8000.

Still on *Motor Mania*, Kamal Farmah suggests that, when you get out of the gas station, turn left instead of going straight on. You will disappear to where the police car usually comes from. Push the joystick forward and you'll find that whatever comes near can't kill you.

Next, US Gold's *Zaxxon* for the 64, courtesy of Paul Smith. Type the word RED at the start of the program to enter cheat mode. You are now immortal.

There's a bug in *Roland In The Caves* for the Amstrad, according to Ian Leitch. When you fall in the cave, hit the down-arrow key as soon as you appear. The machine thinks that you have jumped out of the cave and multiplies your points total by 10.

On *Crazy Kong* for the 64, says Andrew Mills, stop the program by pressing RUN/STOP and RESTORE. Then, LIST 400 and look for a statement that says L=L+1. Change the 1 to a 9 and this will change the level of play.

J Bonde offers the following tip for *Mr E* on the BBC. First, *LOAD "MAIN PROGRAM" 1900 then enter: ?&1ECB=&EA. Then use CALL &4300 to start the game, and you will be immortal.

HELP FOR THE VIC

M J Davies, like many others, complains about the lack of Vic tips. To remedy the situation, he's sent me the following very useful list. So, all you Vic owners, get your digits tapping and try these:

Perils of Willy: For infinite lives, reset the Vic then POKE 36879,8: POKE 646,1. Rewind the tape and VERIFY. When the cursor appears, type SYS 64802. Then type LOAD and press PLAY. After a while, the word READY will be printed. Press RUN/STOP and RESTORE then POKE 11020,204. SYS 12269 should start the game.

For *Vic Jet Pac*, rewind the cassette and LOAD the loader program. Change lines 50 and 110 to 110 DATA 160, 31, 32, 66, 2435, 160, 255, 140, 232, 35, 136, 140, 219, 35, 76, 29, 32

Type Run. The game will load and both players will have 255 lives.

Next, *Abductor*. Reset the Vic, rewind the tape, VERIFY the loader and stop the cassette. LOAD the main program then POKE 6869,255 and type RUN.

Finally, *Myriad*. Reset the VIC, rewind the tape, VERIFY the loader and LOAD the main program. POKE 1512,255 and then SYS 1175. Again, you'll have 255 lives. Thanks, Mr Davies, the cheque's in the post!

DIY WITH C&VG!

Redmond O'Leary says he actually likes all the adverts that appear in *C&VG*. He says that they're so colourful, he papers his bedroom wall with them. And, because there are so many, he can change them every month, saving him the cost of the paint. So you see, what other magazine lets you paper your bedroom for just 95p a month?!

Finally this month, a word to the person who sent me a mailbox on Micronet asking what I do on Saturday nights. Open letters, usually! And write *Bug Hunter*.

BY ROBERT SCHIFREEN

Experience the thrill of Formula One Motor Racing



POLE POSITION



TOP	7058	TIME	1:22.48
SCORE	3028	IN	SPEED 166 MI

This genuine reproduction of one of the worlds most popular arcade classics gives you the chance to experience the thrill of Formula One motor racing! Enter the practice sessions. Race against the clock to qualify. Dice with other drivers for the lead. Only your skill and endurance see you to the chequered flag first!

CASSETTE £9.95 DISK £14.95



Premier Arcades™ from **Datasoft**



For a change, this month let us look at the people who play pinball — players who have established themselves as a little bit special.

First, let's be under no illusions. Luck, both good and bad, can play a major part in a game of pinball.

Now, let's stir up the population north of Watford. All of the players I am about to mention come from the south of England. I honestly don't know of any outstanding northerners. Maybe you know differently . . .

London-based, Geoff "Arcade Attack" Harvey, is a superb player. Geoff plays very much in the American style, very animated and highly self-critical. When watching Geoff play, stand well back.

From a small Norfolk village comes Phil "The Greek" Oakley. The nickname doesn't denote his nationality, but his uncanny ability to pull off a shot called "Greeking".

Steve Dyer, of Slough, is a fine player with a style that contrasts with that of Geoff. He stands very upright, uses total concentration and the only movement is the flipper fingers.

Last, but not least, there is the legendary Graham "Fourth Ball" Goose from Norwich — so called because of the wicked consistency with which he destroys his opponent on ball four. He is also famous for his unusual stance, feet well away from the machine.

These are just four of the country's very best. There are others, of course, and hopefully some of them live up north . . . So let's hear from some of you up there!

IT'S A RECORD FOR ROBOTRON!

James Thomas has done it again! After a marathon attempt to play *Robotron* into the ground, we believe that a new British record now stands.

James is a second year geology student at Leicester University and a very keen alien basher. Just over a year ago, he scored a magnificent 80 million on *Juno First* (*C&VG* July 1984) and smashed the world record in an amazing 30½ hours.

Friday, February 8th was the day picked for nailing *Robotron* and started with an early delivery of the machine, donated by Keeday Leisure who fitted it with two brand new super deluxe joysticks especially for the marathon. Camp was set up with sleeping bags, blankets, food and lots of music to offset boredom.

determined not to use his secret weapon — caffeine tablets — until they were absolutely necessary.

During short restbreaks to give him time to recharge his batteries, James' trusty lieutenant, Paul Westmore, took over to prevent *Robotron* from taking over. Twenty-four hours from the start James had picked up a score of 120 million.

By midnight on Saturday, muscle fatigue and boredom set in, although a change in the music helped. He carried on for a while longer but, by 2.00 am on Sunday morning, James had to stop with a score of 196 million which took an incredible 42 hours to accumulate.

The world record still stands at 348 million but James has brought the British record closer to this massive



MR DO CLOWNS AROUND

Some games are instant hits in the arcades and fizzle out after a few short months. Other games are known as "steady earners" and those are the ones — like the Mr Do series from Universal — that catch your eye, are easy to play and always remain popular.

Mr Do's Wild Ride is the third in the series and has proved itself to be universally liked. Pun . . . Sorry! You play the part of Mr Do who's a cute little clown having the time of his life on a roller coaster.

The aim of the game is to get to the goal at the top of the screen which means that Mr Do has to make a hair raising climb using the roller coaster as a sort of ladder. Take great care to ensure that a coaster doesn't whizz by and flatten him.

If a coaster does come shooting round a bend, there are escape ladders that will take him out of danger. However, if his feet are safely off the track on one level, his head may well be poking above the track on the level above.

Fruit and a wide variety of objects let slip by happy passengers can be collected to earn extra points — but don't get too enthusiastic over these and lose sight of your goal!

Unlike the majority of games where the aim is to increase your score, *Mr Do* starts off with 4,500 points which decrease when the game starts. The longer you take, the lower your score. Speed and strategy are very important. An accelerator button can be used in emergencies to hasten Mr Do out of sticky patches

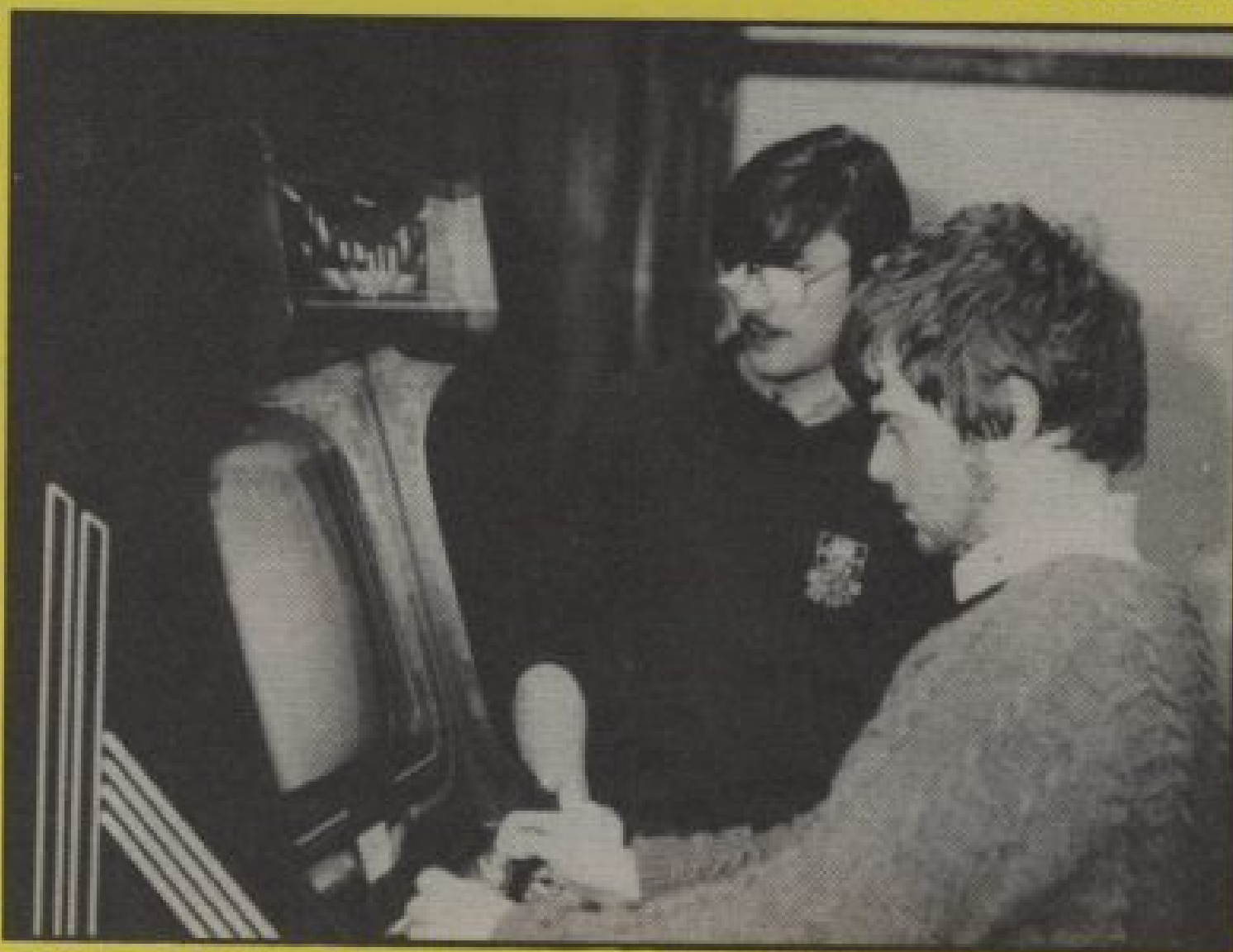

Photo: Michael Mullray

Play started at 10.00 am and James describes the first few hours: "The scoring was slower than was hoped and doom, gloom and despondency set in after 12 hours with a score of only 60 million."

With a heavy snowfall, the temperature dropped rapidly throughout the night but hot food and drinks were in constant supply.

Fatigue began to take its toll towards dawn of Saturday but James kept going,

figure. The photo of the dead-beat duo was taken 34 hours into the marathon with James at the helm.

Although he found out a few days later, James didn't realise that he had glandular fever at the time and did very well keeping going for 42 hours.

If you think you have beaten a world or British score at your favourite game, write into *Arcade Action* and we'll do our best to verify your score for you.

although this causes the score to decrease faster.

When the letters EXTRA appear over the goal and if you can remove those, you will be awarded an extra life. Likewise, if you get to the goal while a diamond is in residence, you will earn a replay.

The game ends when your score reaches zero. *Mr Do* is a colourful and snappy game which generates a lot of skill on later levels.



GET TO GRIPS WITH GALAGA

Galaga has always been a favourite of those players desperate for a fast, colourful shoot-'em-up. Julian Rignall, super champ of C&VG's 1983 Arcade Championship, shows you how to beat the Galagas at their own game. Over to you, Julian.

There are three types of aliens in *Galaga*: blue, red and Boss Galagas. Blue ones always loop back at the bottom of the screen, describing a circle before going past your fighter, and red ones swerve crazily down the screen straight past you to return to the top. Both these aliens are worth twice as much in the air.

The Boss Galagas are the most important — apart from being the key to high scores — worth 400, 800 or 1,600 points depending on the size of escort, they also do something special. Every second Boss which comes down the screen emits a tractor beam to capture your fighter. If you hit the Boss who captured your fighter, it descends to

join your current fighter as a tandem team with double fire power.

All Galagas shoot very accurately to where your ship is positioned so it is important never to stay too long in one place.

When starting a game, the Galagas always come from the top and sides in lines making a formation at the top of the screen. They always create the same formation but have three different patterns. These are always consecutive and are essential to learn so you know where the next Galagas are coming from.

On screen one, these lines of Galagas don't drop bombs but on screen two they do. After wave one, there are more Galagas in the formation than needed so the excess Galagas peel off and make death dives towards you. At screen 16, there are the maximum numbers of Galagas in the formation with up to six of them making dives at your fighters.

When the formation is complete, some Galagas start to break away from the group to dive bomb your craft — not many on screen one but up to 12 or more from screen 20. By screen 12, it is now that your memory of the lines of Galagas in formation becomes essential. Try to blast them all before they form at the top and have a chance to attack.

Keeping up a constant barrage of double firepower will leave only a few Galagas left to kill. Another point worth mentioning from this screen onwards — any Galaga that goes past your fighter will dive again as usual, but this time at twice the speed.

From screen four onwards there is a Bonus Galaga. During a wave, a red or blue Galaga will flash a few times and mutate into three aliens — the destruction of all three will result in a 1,000, 2,000 or 3,000 points bonus. The mutation is always heralded by a noise so keep an ear out for this as they will help to boost your score.

The special feature of *Galaga* is its "challenging waves" — these appear after

stage two and on every fourth stage thereafter. These consist of 40 aliens which appear separately in five groups of eight. They don't drop bombs and come in patterns which are easily memorised.

It is essential to memorise these waves to achieve maximum bonus points from each wave because, after each one, it states how many aliens were hit and multiplies the sum by 100 points, ie 20 aliens give 2,000 points. If all 40 aliens are killed, then a special 10,000 points are given. This is the key to the high scores as it is possible to obtain 36,000 from one challenging wave. Also the last alien shot in the line is worth between 1,000 and 3,000 points depending on where it is.

A few other points to remember — try not to shoot the Boss Galagas until they come down the screen after formation because of their point value. They might also beam. Memorize the line patterns prior to formation and the challenging wave patterns. Also remember wave ten and 18 are exactly the same as screen one, apart from the fact that screen 18 is twice the speed.

Finally, listen out for Bonus Galagas and keep up a constant barrage or else you won't last long! By the way, after screen 30 the game doesn't get any harder.



CAN YOU BRAVE THE BANDIT BANK?

Bank Clerk needed immediately.

\$1000 per month.

MUST shoot straight and have steel nerves.

Those of a nervous disposition need not apply. The job description for a bank clerk in

Mexico is a little strange but, when playing Sega's *Bank Panic*, you'll understand.

At one time, the bank in



question was well known to bandits as easy money and they attacked repeatedly, bursting in, brandishing a shooter and walking off with the loot.

One day the bank manager woke up to the fact that more money was flowing out of his bank than was being deposited and installed an early warning system.

You play the bank clerk and, as the citizens come in to deposit their money, you have to make a split second decision as to whether they are genuine.



You sit facing the 12 entrances, keeping a watchful eye on the warning grid above each door which warns of anyone approaching. Using the joystick, you scroll right and left until you have three doors filling the screen and wait for them to open.

The key to success is quick reflexes. As someone opens the doors, you have to wait to see whether they will pull a gun on you. Only then can you open fire. Shooting before a gun is pulled could mean that you murder an innocent citizen. The game has been well designed in that some bandits delay a moment before pulling their pistols. It leaves you gripping the joystick sweatily in anticipation.

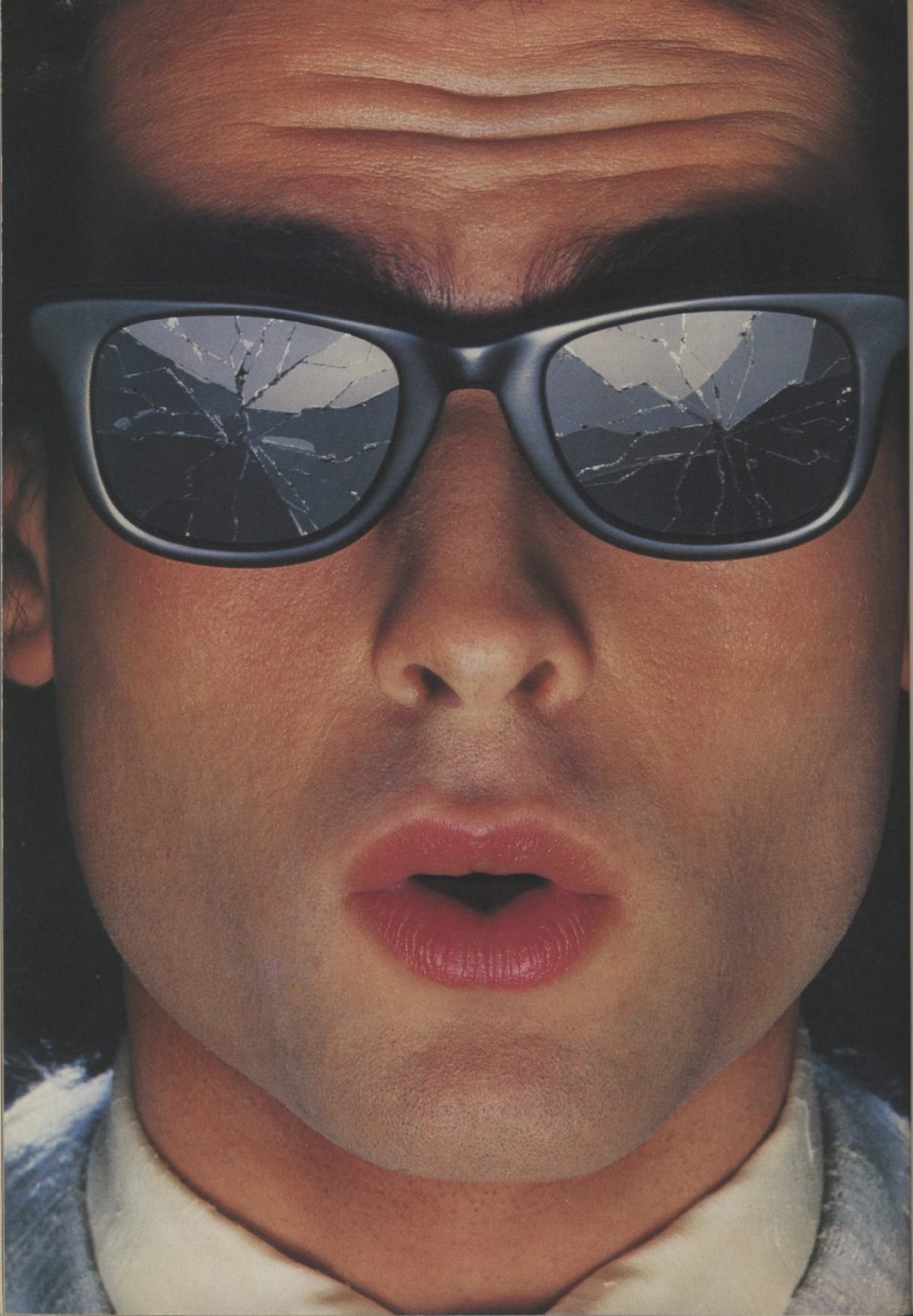

You should see what he's just seen.

Micronet 800.

Stretching the mind of your micro far beyond its limits.

Micro evolution continues with this unique communications, information and software system. Set on our mainframes nationwide.

Includes 30,000 pages and access to Prestel™ with its full range of services.

A tremendous Communications section that networks you to thousands of other members across the country. Send and receive electronic messages and graphics at a touch of a button.

And there's the Chatline service, Swapshop and Teleshopping.

Check with daily updates on the very latest computer news.

Micronet also has its own huge facts data base.

And a choice of up-to-the-minute software to download absolutely free.

For only £13 a quarter and just a local telephone call whenever you want to connect up (that's only 22p per half hour at cheap rates) you could be part of Micronet.

The only accessory you need is a Modem.

A small price to pay to join the other visionaries on this exciting new system.



Fill in the coupon for more details and send to Micronet 800, Durrant House, 8 Herbal Hill, London EC1R 5EJ.

But be warned, Micronet 800's features are almost limitless and constantly updating. So maybe you'd be better to call in at Laskys, John Lewis, main Boots or your local Micronet 800 Action Station.

To feast your eyes on all the amazing things it can do.

To: MICRONET 800, Durrant House, 8 Herbal Hill, London EC1R 5EJ. Telephone 01-278 3143.
Please send me the full facts about Micronet 800.

Name _____

Make/Model of Micro _____

Address _____

Telephone _____

CVG5

*For 97% of telephone users.

**Prestel is a trademark of British Telecommunications.

MEGA HITS



SPECIAL

OFFER

Here's an offer you just can't refuse. C&VG, your favourite computer games magazine, has teamed up with Beau Jolly to bring you an EXCLUSIVE money saving offer.

Beau-Jolly are releasing two tapes, for the Commodore 64 and the Spectrum, called *Mega Hits*. Each games tape features 10 top games from top software houses like Quicksilver, Beyond, Alligata, Anirog, Interceptor, Taskset, Micro-power, Micro-Gen, Elite, Melbourne House, PSS, Realtime and Micro-

sphere. All the games have featured highly in the C&VG Top 30 charts.

And we're offering you the chance to get your hands on one of these tapes for the special C&VG reader's price of just £16.49! A genuine bargain!

All you have to do is fill in the coupon and send it with your cheque/postal

order/credit card number to the address shown. Then just 28 days later a bumper bundle of the top games of 84 will come crashing through your letter-box. Don't delay - rush your order form off today!

Games on the Commodore 64 *Mega Hits* tape are: *Tales of the Arabian Nights*, *Poster Paster*,

Flight Path 737, *Psytron*, *Son of Blasser*, *Super Pipeline*, *Trollie Wallie*, *Automania*, *Ghouls and Booga-Boo*.

Games on the Spectrum *Mega Hits* tape are: *3D Starstrike*, *Blue Thunder*, *Son of Blasser*, *Automania*, *Booga-Boo*, *Psytron*, *Wheelie*, *Fall Guy*, *Blade Alley*, and *Penetrator*.

To: Mega Hits Special Offer, *Computer & Video Games*, Priory Court, 30-32 Farringdon Lane, London EC1R 3AU.

BLOCK CAPITALS PLEASE
Please send me:

Qty Mega Hits Machine @ £16.49 Total

I enclose a cheque/postal order for £.....made payable to *Computer & Video Games* magazine.

Please debit my Access/Visa account no.

for £.....

Signed..... Date.....

Name.....

Address.....

Tel.....

Offer applies to UK readers only. Allow 28 days for delivery. Offer applies while stocks last.



Playability: Will the game keep you up until the early hours of the morning, as you attempt to complete just one more screen in a desperate attempt to beat it? Or does it send you to sleep the moment the intro-screen appears? Could you spend hours locked away in your bedroom with it?

continued from page 24

an owl and finally the witch herself as she bids to save the village from an erupting volcano. There are four screens packed with neat "cute" style graphics and several skill levels.

To say much more about the plot would be to give the game away — the cassette inlay instructions don't give much away either. You have to work out what the witch must do to progress to the next screen by solving the riddles that the instructions set!

● Graphics	9
● Sound	8
● Value	8
● Playability	9

DAY IN THE LIFE

MACHINE: Spectrum
SUPPLIER: Micromega
PRICE: £6.95

Programmer Stephen Redman picked a controversial subject for his first game — Sir Clive Sinclair.

You have to guide Sir Clive through a very important day in his life — the day he has to pick up his knighthood from Buck House!

He has to brave the difficulties of getting dressed in his computerised house, the terrors of commuting, the problems of making a cash-card machine actually cough up and the perils of shopping.

The game isn't just good because of its novelty value — it is playable too. Lots of puzzles to be solved and lots of fun to be had doing them! The graphics are big and bold and the little "Sir Clive" character is really neat!

No, we don't yet know what the man himself thinks about the game. But watch C&VG to find out.

● Graphics	8
● Sound	8
● Value	9
● Playability	8

GANDALF

MACHINE: CBM 64
SUPPLIER: Tymac
PRICE: £9.95/£14.95

The great white wizard Gandalf leaps from the pages of *The Hobbit* and *Lord of the Rings* to take part in a small skirmish with an evil bunch of Lizard men who are about to make off with some of his best apprentices. Tymac have come up with a novel adventure style shoot-'em-up in which you control Gandalf and his deadly spells to blast the Lizard men who are attacking your castle.

Hordes of the creepy green things swarm towards you from the forest which surrounds your castle. Blast them with a spell and they turn into gold coins — you can nip out and pick these up if you are brave enough! The Lizard men have a nasty friend in the shape of a poisonous spider who sneaks into the castle and attacks our hero in a particularly nasty fashion.

It's inevitable that the Lizard men eventually get through your defences and drag away an apprentice — though you can follow him in an attempt at rescue.

Gandalf the Sorcerer is a two screen game with nice graphics and good sound. A nice change from blasting aliens from beyond the stars. Addictive too!

● Graphics	8
● Sound	8
● Value	8
● Playability	9

DUKES OF HAZZARD

MACHINE: Spectrum
SUPPLIER: Elite
PRICE: £6.95

At last! The long awaited debut of the Duke boys hits the computer scene. And although the game isn't as spectacular as one of those amazing stunts you see the General

Lee perform on TV, it 'ain't bad either.

The basic idea of the game goes like this. The Dukes need cash to pay off Boss Hogg — and to get it they decide to enter a road race which has a \$5,000 prize. But they have to get to the start of the race first — and the Boss and other assorted baddies are out to stop the General Lee getting there!

You have to drive the General across some rugged countryside — avoiding other vehicles, dodging bombs from helicopters, bi-planes and even a hot air balloon.

Dukes is basically a scrolling scramble-type game — with cars instead of spacecraft. The graphics are nice and the scrolling pretty smooth. It takes a while to get used to the controls — you can make the General jump and swerve around the roads — but once you've done this you can get stuck in.

I particularly enjoyed the "crash" sequence. The General does a neat three point spin before coming to rest!

Hazzard fans will enjoy the game. The rest of you should take a look at a demo first. Listen to the General Lee musical airhorn at the start of each game. A nice touch...

● Graphics	8
● Sound	6
● Value	7
● Playability	7

BANJAX

MACHINE: BBC
SUPPLIER: Robico Software
PRICE: £9.95

Legend has it that any bear intelligent enough to reach the Inner Sanctum of the Golden Temple shall become Lord of the Lands of Mystery. Will Banjax prove to be such a bear?

He might well, because this is not the hardest game you've ever played. It's a

mixture of arcade and Adventure in which you send Banjax scurrying around a series of locations, including hedge mazes, woods, mountains and castles — 240 screens in all — in search of the elusive Inner Sanctum.

Needless to say, there are various nasties to contend with — birds, spiders, snakes and blobs — which kill if you touch them, but they're a bit slow and not very fearsome.

The graphics are simple and effective and the game has an attractive slick feel, but it falls rather uneasily between arcade and Adventure without being one or the other, and there's not really enough mystery and variety to keep you coming back for more.

● Graphics	8
● Sound	5
● Value	6
● Playability	8

BRUCE LEE

MACHINE: Spectrum
SUPPLIER: US Gold/DataSoft
PRICE: £7.95

Bruce Lee haunted the pages of C&VG's reviews section for months after the CBM 64 version first appeared. And now he's back — on the Spectrum.

Briefly, the idea of the game is to help Bruce get to a wizard who is hiding inside a vast fortress protected by Ninja soldiers and the indestructible Green Yamo.

Bruce has to kick and chop, leap and hop his way through the fortress in this neat twist on the regulation platform game theme. The animation of the characters is great, the graphics bold and colourful — and the game features some unique multiple player/player vs. computer options.

● Graphics	9
● Sound	8
● Value	9
● Playability	9

SUPER

HUEY

UH-1X



WAKELIN.

SOLO FLIGHT - Computer controlled flight training teaches the techniques of flying and familiarization with instruments.

RESCUE - Your assignment is to locate and attempt pick up of stranded military personnel.

EXPLORE - Fly a survey mission over previously unexplored territory and map the terrain.

COMBAT - Use your rockets and machine guns to defend a secret desert installation from unknown hostile forces.

**HELICOPTER
FLIGHT SIMULATOR**



COSMI

CASSETTE **£11.95** DISK **£14.95**



U.S. Gold Ltd., Unit 10, The Parkway
Industrial Centre, Heneage Street,
Birmingham B7 4LY. Tel: 021-359 3020.



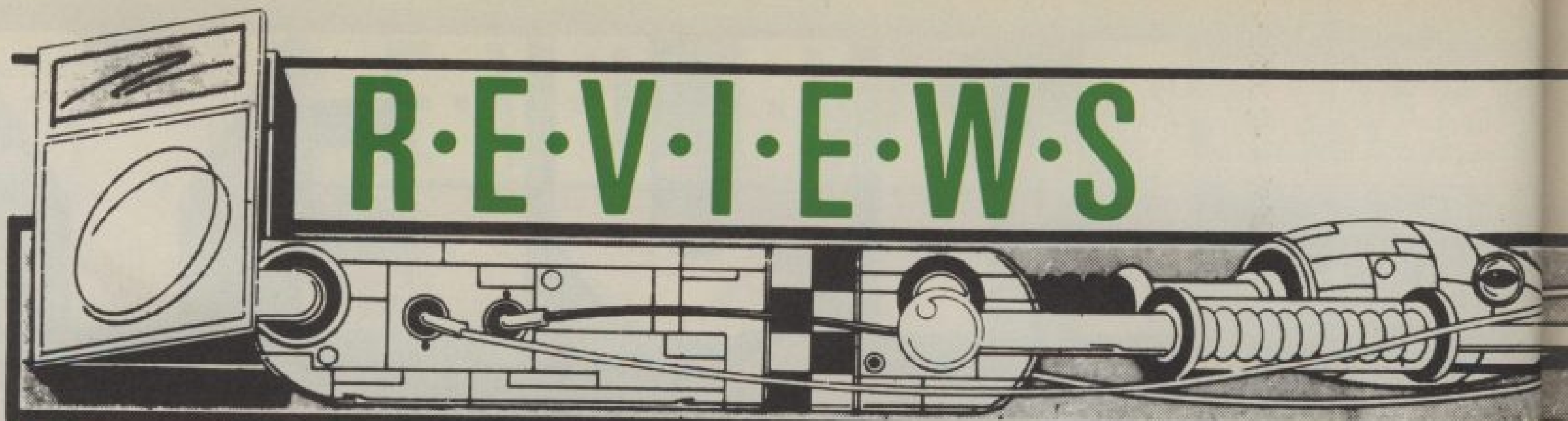

R·E·V·I·E·W·S

9 CAULDRON

MACHINE: CBM64/
Spectrum
SUPPLIER: Palace
Software
PRICE: £7.99

You've already read about the fantastic graphics in last month's C&VG. Now read how the game is great fun to play!

The basic idea of *Cauldron* is to help the witch defeat the evil Pumpkins and rescue the Golden Broomstick. To do this, the witch must brew up an evil potion in her cottage cauldron and find the Pumpkin leader in his hide-out deep within the mysterious planet.

The witch's quest takes place in, over and around her home world. The programmers have created an entire planet — with forests, seas and islands above ground and weird caverns underground.

There are lots of things to discover and puzzles to be solved — and the first C&VG reader to complete the game and send us a map will win the real Golden Broomstick. So we're not giving too much away here!

● Graphics	9
● Sound	9
● Value	9
● Playability	9



10 HYPERSPORTS 2

MACHINE: All MSX
SUPPLIER: Konami
PRICE: £15.00

Here is yet another offering from the Konami house for the sports enthusiasts. With the usual detail and superb use of graphics.

In the first part of the



game, quick reactions are required in the Skeetshooting (clay pigeon) event.

Vertical elevation of your gun sight is automatically set up by the computer and is shown by two small squares on the screen which move up and down. To get proper horizontal aim, match the swing of your gun with the flying targets, firing with either the space bar or joystick button.



The marksman grins or frowns according to his success, leading to the second event, Archery.

In essence, by looking at the target display, you can see if you are high or low, left or right and adjust accordingly with the following arrow. At the bottom right hand corner, the score of the last arrow is shown and the amount of arrows remaining are shown in a slot next to the archer. The upper screen display is in the same format as the previous event. Quite a degree of skill and judgement needs to be exercised to achieve consistent results. Qualifying for the next event

is one thing, world records are another, but at least you can move on to the Weightlifting event.

It goes without saying that here is another graphical treat. In addition to the already familiar information at the top of the screen, there are two further items showing a countdown from 30 seconds to zero and the weight being lifted in kilos.

When all three events have been successfully completed, you return to Skeetshooting, but this time the qualifying scores in all events will be higher.

Hypersports II has all the essential ingredients, from the judgement necessary for the first two events, to the sheer necessity of pounding the keys for the weightlifting.

● Graphics	10
● Sound	7
● Value	10
● Playability	8

11 E'ONE'S A WALLY

MACHINE: Spectrum/
CBM 64
SUPPLIER: Micro-Gen
PRICE: £9.95

The adventures of Wally Week, videogame superstar, continue in the only game to come with a "hit" single on the

B-side!

Wally, star of *Automania* and *Pyjamarama*, introduces

the rest of his family and friends in this latest graphical extravaganza from the Micro-Gen programmers.

You'll meet Wally's wife, the lovely Wilma, plus Tom the Punk, Harry the Hippy, Dick the Plumber and Herbert the baby — Wally's pride and joy.

Micro-Gen claim this is the first fully animated interactive arcade Adventure. You can control any one of the six characters — except baby Herbert — at any stage during the game.

The object of the game is to help Wally open the safe in the bank in order to pay the game some wages. In order to do this, certain tasks have



to be done and certain puzzles solved.

Each member of the gang has different characteristics and abilities — and you must decide which one can solve certain puzzles and complete certain tasks as you play the game.

Each character has three lives to begin with — and you must keep everyone "alive" throughout the game to succeed.

The graphics are excellent. The characters are drawn in true "cartoon style" and the backgrounds are packed with detail.

As in *Pyjamarama*, Wally's latest Adventure, the game includes both arcade style shoot-'em-up screens as well as arcade Adventure sequences.

Everyone's a Wally will keep you busy for hours — and when you've solved it you can still admire the pretty graphics.

The song, by Mike Berry, will have you humming along too — but, beware, prolonged

R·E·V·I·E·W·S

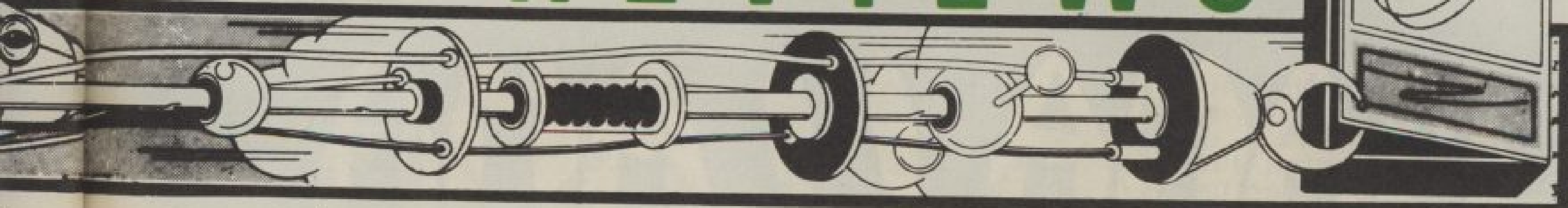

exposure to the music could cause a severe case of terminal whistling!

● Graphics	10
● Sound	8
● Value	9
● Playability	10



12 YIE AR KUNG-FU

MACHINE: All MSX
SUPPLIER: Konami
PRICE: Not Known

STAR GAME

Yie Ar, I am reliably informed, means one-two, and in this terrific game everybody gets the one-two treatment. This game will surely become a classic among those of us who have fancied themselves as exponents of the martial arts. The background is an oriental setting where competitors traditionally knock ten kinds of bells out of each other.

The top of the screen displays the score of Lee (yourself) and his particular opponent at that scene, together with a long bar which shows the "ki" or energy remaining for each. When the "ki" starts turning red, either you or your aggressor are in trouble and it's nearly knockout time. Beginning the game with three Lees, you get an additional life at 30,000 and 50,000 points.

The remaining Lees are shown after the indicator "Rest" and control of the action is either by joystick or keyboard.

The controllable actions are vertical jump, high kick, advance and retreat, low kick, punch and duck. The fire button must be activated to score a hit while using any of these techniques. You can also jump clean over your

opponent and deliver a flying head kick, but again timing and the point of contact need to be spot on.

The scoring is quite complex, ranging from 100 points for a straight punch, to a flying kick or footsweep at 500 points.

It all sounds great so far, but until you see the speed and moves that your opponents can make, you don't realise what you are in for. If you back him into a corner at either side of the screen, he simply nips round you and starts attacking from the other side. All opponents have the same striking power as Lee and most have additional weapons.

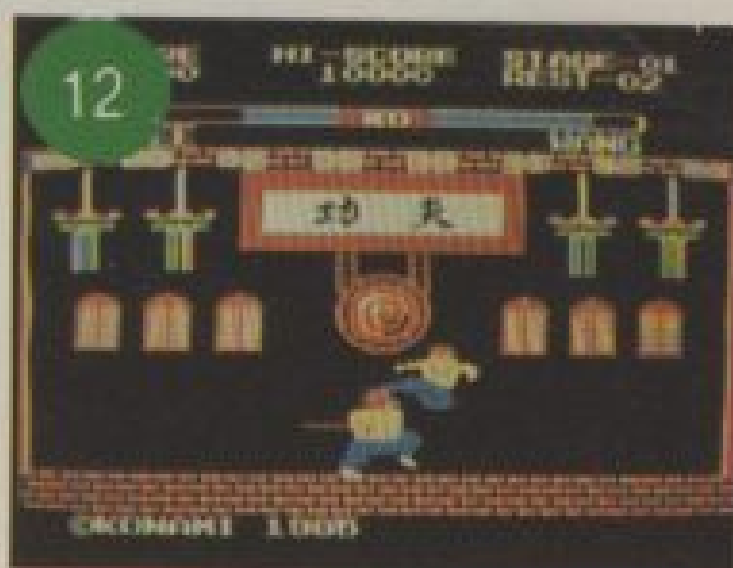

On stage one, Wang has a large stick which he wields very freely in addition to his other moves. The second stage has Tao spitting fireballs at you if you retreat too far. Chen, your third adversary, has a nasty length of chain which reaches out towards you and, incidentally, looks like Pluto in a green leotard! At stage four Lang is armed with throwing spikes and stage five has Lou springing through the air to connect with you.

You can hit the fireballs and throwing spikes at high and low levels to score extra points. Between stages there are also bonus points to be scored by hitting lamps, bottles and bricks moving at various levels. When you have reached stage five, you return to your first opponent and start amassing more points.

This game is very challenging. The superb graphics and background oriental music add authenticity to what, I am sure, will be a very popular game. If you

haven't got an MSX, beg or borrow one just to play this game.

● Graphics	10
● Sound	7
● Value	10
● Playability	10

13 CASTLE QUEST

MACHINE: BBC B
SUPPLIER: Micropower
PRICE: £12.95 cassette
£14.95 disc

I have not played anything like this before. It is fabulous. Let me explain. *Castle Quest* is an arcade Adventure game set in a large castle made of colourful bricks, planks and ladders with many objects, such as a torch, gold bar and an aqualung, scattered around. Like traditional Adventure games, the object of the game is to solve many puzzles and ultimately to find the wizard's treasure. The thing is, all this is played

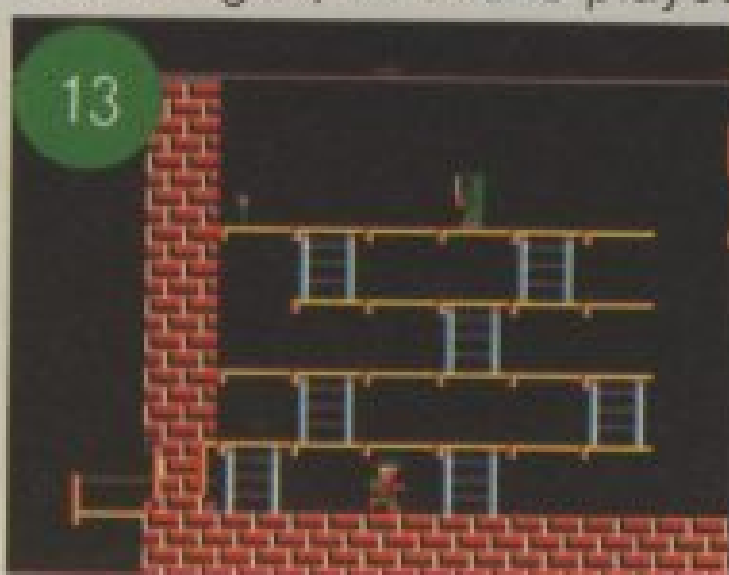

in beautifully animated real time arcade action which requires a high degree of digital dexterity.

There are many monsters patrolling various passages, usually in twos and threes. As you are not allowed to zap these creatures, you have to find a way to avoid them or fend them off with some of the objects found. The finding of objects will not score you any points, however. You are awarded points when you solve the puzzles which are all fairly tricky, almost to the standard of text based Adventures.

Therefore, *Castle Quest* is not an easy game to play. I expect many of you will be stuck for a long time without scoring a thing. Many times I

was caught by a mob of green hairbrushes and thrown into prison. It took me ages to work out how to escape from the prison by experimenting with some of the objects found inside the cell. The solution was perfectly logical but, since the execution of it is in an arcade format, it took a lot of attempts to finally work out the timing. Once you've made your escape, you will be able to do a fair bit of exploration.

As I said, this game is difficult but it is one of the few games which was so addictive I couldn't stop playing it. It is not for those who are new to arcade adventures but is a must for anyone who can cope with games like *Elite*. Go and buy it if you like a challenge.

● Graphics	10
● Sound	9
● Value	8
● Playability	9

IN SPACE

MACHINE: CBM 16
SUPPLIER: Microdeal
PRICE: £6.95

Microdeal's freckle-faced hero comes to the C16 with a colourful, well presented game. Cuthbert is on a looting mission. He has to collect fuel pods from several platform-style planets and return them — individually — to his space-shuttle. Avoiding various nasties, of course!

Sometimes Cuthbert's shuttle has engine trouble — and he has to hunt for vital spares before the ships blows up.

An action-packed game — with keyboard or joystick options available. Nice bold, colourful graphics and good sound all go to make this one of the better C16 games around.

● Graphics	8
● Sound	8
● Value	8
● Playability	8

MAMA LLAMA



commodore 

Price £7.50

LLAMASOFT

ORIGINAL SOFTWARE DESIGN

AVAILABLE FROM W.H. SMITHS, BOOTS, WOOLWORTHS AND MOST COMPUTER RETAILERS OR FROM LLAMASOFT 49 MOUNT PLEASANT, TADLEY, HANTS (TEL. 07356 4478) SAE FOR CATALOGUE & NEWSLETTER

'THE NATURE OF THE BEAST!'

Software

R·E·V·I·E·W·S



Sound: Does the game sound like a Duran Duran LP played at half speed — or does the noise from your micro knock you half-way across the room. The C&VG review team don't judge games with their ears plugged up, we can tell you!

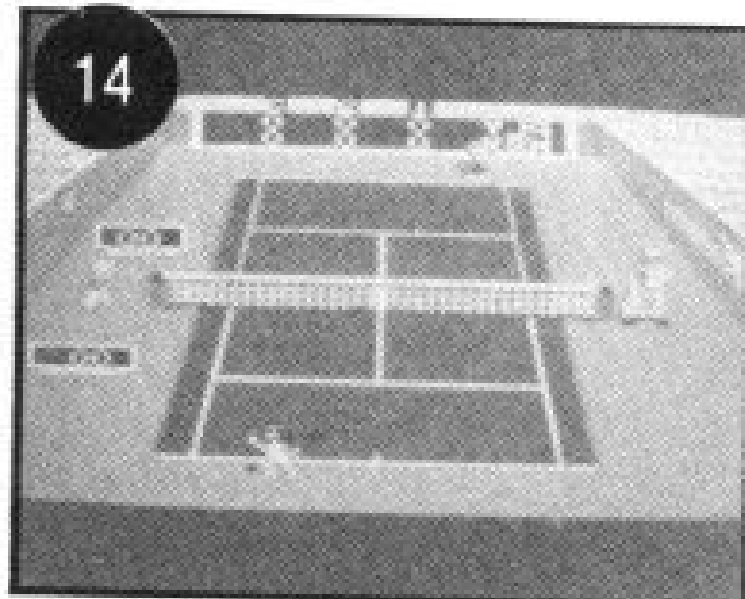

14

points is identical to the real game. The joystick movements controlling the player are self evident, but you start to use your skill from the serving aspect. A quick blip of the fire button (or spacebar) is all that's needed for the ball to leave the player's hand for serving. It is the time lag between this and the second blip that determines whether or not you clear the net and the distance you are able to hit it. Should you net it, the ballboy crouched on the sideline dashes out and retrieves it. Some games allow room for error inasmuch as a near miss is enough to connect. Not so with this game, where you must be correctly positioned, getting your racket behind the ball to move it. Players only change ends in the two player version and in the other options you control the player or players at the near end of the court.

Altogether, this game is very engrossing and requires lots of skill and co-ordination. I believe that the majority of purchasers will find this game good family entertainment. The only details omitted were abusing the umpire, breaking rackets and destroying the soft drinks stand!

● Graphics	10
● Sound	7
● Value	10
● Playability	8

15 SOFTAID

MACHINE: Spectrum/
CBM 64
SUPPLIER: Quicksilva/CTW
PRICE: £4.99

Softaid, the £4.99 games tape consisting of ten best selling games for the price of one, was launched in February at the LET show at Olympia.

Based on the Band Aid project founded by Bob Geldof and Midge Ure, *Softaid* was launched jointly by Quicksilva and industry newspaper

Computer Trade Weekly. *Softaid* is a compilation tape of some of the best games around for the Spectrum and CBM 64.

The Spectrum version comprises *Spellbound* (Beyond), *Star Bike* (The Edge), *Kokotoni Wilf* (Elite), *Ant Attack* (Quicksilva), *Sorcery* (Virgin), *Gilligan's Gold* (Ocean), *Horace Goes Skiing* (Melbourne House/Psion), *3D Tank Duel* (Real Time), *Jack and the Beanstalk* (Thor) and *The Pyramid* (Fantasy).

The Commodore 64 version comprises *Pitfall* (Activision), *China Miner* (Interceptor), *Star Trader* (Bug Byte), *Falcon Patrol* (Virgin), *Fred* (Quicksilva), *Flak* (US Gold), *Gumshoe* (A 'N' F) and *Gyropod* (Taskset), along with *Gilligan's Gold* and *Kokotoni Wilf*.

For each tape sold, £3 upwards will go directly to the Ethiopian Appeal.

The tape is great value for money — even if you have one or two of the games on it already.

● Graphics	10
● Sound	10
● Value	10
● Playability	10

16 DROPZONE

MACHINE: Atari
SUPPLIER: US Gold/
Datasoft
PRICE: £9.95 (Cass)
£14.95 (Disc)

This must be THE game of the moment for frustrated Atari owners with no new games to play. It's a fast moving combination of *Defender* and *Jet-Pack* with terrific graphics and sound — and a really neat line in explosions.

The general idea is to use your spaceman/jetman to help protect some poor little humans desperately attempting to reach home base on a hostile planet. *Defender*-style alien nasties are attempting to get them — and you Use your jetman to

swoop down and help the humans reach the "dropzone" and safety.

Fast smooth scrolling — as you'd expect from the Atari — nine different alien attackers and superb moon landscape graphics go to make this the best Atari game around right now.

Atari owners can't afford to miss this one!

● Graphics	9
● Sound	9
● Value	9
● Playability	10

17 OSPREY!

MACHINE: Amstrad
SUPPLIER: Amsoft/BES
PRICE: £9.95

Here's a game for the ornithologists and conservationists among our readers. It's already available for the Beeb, so you might well have seen

Osprey! at school.

The basic idea of the program — which is more of a strategy game than anything else — is to help protect and increase the breeding pairs of ospreys at their only nesting site in this country, Loch Garten in Scotland.

You are told — each season — how many people you have to work at protecting the birds. You have to allocate your team to jobs like nest watching to prevent egg stealers sneaking in and stealing eggs, working at the site or informing the public about the ospreys and their fight for survival. The way to utilise your resources reflects on the success of the ospreys breeding.

Overall a nice game — sort of educational — but don't let that put you off. You get a really nice booklet telling you all about ospreys with the package too!

● Graphics	7
● Sound	7
● Value	8
● Playability	8

14 TENNIS

MACHINE: All MSX
SUPPLIER: Konami
PRICE: £15.00

To me, having to watch tennis on television is a punishment and, when the family turn it on, I turn off!

However, I was soon to find Konami's *Tennis* a whole different ball game!

The game can be played either by a single player against the computer, two players against each other or two players against the computer in doubles. There are three levels of difficulty, from deciding the speed of the ball, to the style and movement of your opponent.

A single player can participate using the cursors and space bar and two players the keyboard, although I would suspect this method would create domestic pandemonium (imagine it on a Spectrum)!

My own standard of playing leaves a lot of room for improvement, so I found the joystick a real help in handling this game.

The player is treated to an excellent perspective view of a tennis court, with grandstands on both sides and a display board showing games, sets and match at the end. The correct court layout, complete with umpire, ballboy and nets, adds to the authenticity. The points for each player are displayed on the right hand side and a small window by the umpire appears at the right moment to show "In", "Fault" or "Net".

The system of scoring



LEVEL 9 ON THE MOVE

Level 9 are moving on to bigger Adventures! Having gone as far as they can with their sophisticated text compression techniques, the next move will be towards disc-based games, according to Pete Austin.

That does not mean that Level 9 Adventures will no longer be available on cassette! Disc will be more convenient to use, but adventurers with cassette systems will be able to run the new games. At certain points in a game, the player will be asked to load in a tape specified by the computer.

For example, suppose such an Adventure were set in a number of

different countries. If, in the game, the player left London and flew to New York, then a tape user would get a message "Insert Tape 3 and press Play on recorder".

In the meantime, Level 9 are on the verge of releasing *The Red Moon* and *Worm in Paradise*.

As well as moving to a new format, the Austins will be moving from their base at High Wycombe. They have found premises in Weston-Super-Mare which will give them more room in which to spread out their business activities. So mail-order adventurers — watch out for announcements of a change of address!

CHIEF EXAMINER FOR PRESIDENT

No club is complete without a President, and we at C&VG are proud to announce that SCOTT ADAMS has agreed to become ours.

There is still plenty of time to join the club, so fill in the form which appeared in our March

issue and send it off to us marked "Adventure Club" to guarantee you receive the bi-monthly newsletter and become eligible for the phone-in Helpline service — not to mention fantastic special offers and events!!

AMAZIN'

Your mission: extremely hazardous. Your clearance: top secret. Your chances of survival: minimal. So starts *Amazon* from Trillium (now renamed Telarium, by the way).

As an agent of NSRT (National Satellite Resource Technology), you are sent to the Amazon to discover what happened to cause the death of a recent expedition there. The natives are hostile, the army corrupt and the volcanoes erupting.

The action starts at NSRT headquarters in Washington, where you are just in time to watch the last transmission from the beleaguered team. The satellite transmission is just coming in and you are invited to tune it in using your joystick. The screen changes to display a receiving screen, with interference and a hissing noise. Movement of the joystick changes the tone of the hissing and eventually you get clear visual reception, alternating with spells of interference.

You are then summoned to the boss's office for briefing and a text conversation follows, in which you are asked your name. I called myself Supremo, of course! At the end of this session, you are asked if the assignment is OK — if you answer NO, the game ends with you getting booted out.

Now follows a series of airplane journeys, including a call on Professor Beneker, where you team up with a friendly parrot called Paco. From then on, PACO is the word for HELP, but he sometimes gets a bit insulting! All sorts of pitfalls confront you and, if you make the wrong choice, it's curtains — from getting beaten up in a parking lot to making a tasty casserole for cannibals.

Therein lies the drawback of this game. The story is narrative in its approach and the player is fairly firmly led along the chosen storyline, with minor deviations, leading in the direction of death. It tends to be almost a multiple choice type of



V'AMAZON

Adventure, only in a discreet way. For example, in Beneker's office, having befriended the parrot, if you try to leave without having taken all the objects that will be useful to you, Paco will squawk in your ear "Better take some more stuff!" and you will not be able to exit the room until you have done so!

The narrative sections are well presented, but are displayed with timing delays for reading and dramatic effect. This means that a replay is slow, with a lot of waiting during events that are repeated. Hence a SAVE disc is a must and saving must be done quite frequently to avoid the frustrations of the narrative delay.

Three levels of play are offered — Novice, Explorer and Leader — so I went into the game from the start at different levels quite a few times to observe the differences. There were none that I could detect up to the point I played, which I judge to be about the half-way mark.

I did discover, though, that the joystick has absolutely no effect on tuning in the signal from the expedition other than changing the sound slightly. The message you are given is a con! The best thing to do is to sit back and let it play.

The packaging is similar to that of *Rendezvous With Rama* and inside the *Amazon* sleeve comes two diskettes, a sheaf of top secret papers telling you how to play the game and a map with coded references on.

There are a few sound effects and some music, plus some of the best graphics I have seen on the Commodore — they really are good. However, graphics alone do not make a good Adventure game and I'm afraid I wasn't over-impressed with this one. It left me feeling that, with the apparently limited choices open to me, I would have been just as well off reading the game in book form.

Amazon is from Telarium for the Commodore 64 and Apple II, both on disc only, priced £19.95.

NUMBER ONE SUSPECT — ME?

Veronica Ashcroft, owner of Ashcroft Farm since the death of her father, was determined to keep faith with a tradition going back 110 years. So she held the Annual Halloween Ball as usual. Too bad I was invited along!

This was a fancy dress ball — they always have sinister undertones, don't they? There were guests there dressed in all manner of strange costumes from a peanut butter sandwich to a six foot invisible rabbit — name of Harvey no doubt!

There was I, dressed as a cowboy, leaning against the bar listening to the local scandal, when what should Veronica do than spill a drink all down her Fairy Queen outfit? She left the ballroom to clean herself up and that was the last I ever saw of her — alive! I swear it!

But guess what was tightly wrapped round her neck when her body was discovered? My lasso! If only Smythe, the damned butler (a gorilla of noble bearing), hadn't got in the way when I tried to follow her, then maybe I wouldn't be in the fix I am now!

This is the setting for *Suspect* which follows Infocom's *Witness* and *Deadline* mysteries. This time you are not the detective but a reporter and, as the title suggests, you are also the prime suspect. So prime, in fact, that it is very likely you will be arrested and convicted.

I said "setting" and I mean just that, for it is not just background. It all happened while I was there! The ballroom was crowded with guests in fancy dress, all moving around the house at will. I started off having a chat with Veronica about her favourite racing horse "Lurking Grue", a steed so black that it can hardly be seen in the dark! Then Veronica left to clean up her dress.

I had a dance or two with Alicia, but she seemed rather cold, so I returned to bar-propping.

The band was playing *Breathless* and this was followed, during the break, with *Stairway to Heaven* on the stereo. I danced that one with Linda.

Shortly after leaving the bar to settle an argument about the price of horses, Colonel Marston returned to announce our hostess had been

murdered! Shortly afterwards, Sergeant Duffy clamped my shoulder in a vice-like grip, and I was under arrest! I was subsequently convicted and, believe it or not, my actions at the party were brought up in court and held against me! I was virtually told how I played the game. My movements certainly seemed suspicious!

The next few times I played the game, I tried different tactics, and each time I could see the same events re-enacted from a different viewpoint. The murder seemed inevitable, so maybe I had better do a bit of snooping to prove my innocence? Looking through this vast mansion revealed nothing at a first pass. Perhaps there was a clue in the tape on the video? I tried to turn it on, but was told: "This is a type you haven't seen before and you can't fathom its controls. It is made by the Frobozz Magic VCR Company." Thanks a lot!

I think that my next course of action is to carefully record the movements of the guests as they wander around the house and farm — and they do seem to wander a lot! The house is huge, with "wings" in all directions. There are many interconnecting hallways — the long hall, the east hall, the front hall and so on.

Of course, if my name was Paul Coppins, I'd be smugly telling you by now how difficult I found it to complete the game. But then it's rumoured that Paul solves an Infocom Adventure before breakfast each morning!

MOSAIC'S DIARY

Watch out in a few months' time for Mosaic Publishing's release of the next most famous diary in the world after that of Samuel Pepys. *The Diary of Adrian Mole (aged 13.5 years)* will be coming to your computer screens as an Adventure game in the early autumn.

Mosaic have commissioned those purveyors of popular problems — Level 9 — to create the game around the Mole diary.

Around the same time, Mosaic will be bringing you a computer game based on the popular TV series *Yes Minister*.

DON'T LET THE GREMLINS GET THE BETTER OF YOU, WRITE TO...



HELP FOR FROGGERS!

Andy Jennings of Blackburn wins a T-shirt for solving a problem with *Crystal Frog*. "On the strength of Simon Marsh's review, I bought the game and agree with him that it has an excellent atmosphere about it. But there is one slight problem with my Spectrum version — you cannot finish it!"

The difficulty starts on trying to open a door, says Andy — a simple task especially as the program tells you it is locked with a four-digit code which he had already found. Getting suspicious, Andy investigated with the aid of the Quill and here's his diagnosis.

An entry has not been removed from the direction table for Location 49 (Vampire Room) which means certain flags are not cleared by the event table on leaving the room. Thus, there is no way to open the door. To cure the problem, using the Quill, delete the movement table entry for Loc. 49 and amend the last entry as follows:

NEW	OLD
AT 49	AT 49
CLEAR 11	CLEAR 11
CLEAR 5	CLEAR 5
DONE	GOTO 48
	DESC

and all will be OK!

Andy hopes this cure will stop many people staying up till 3 am before finally going out of their minds!

HELP WANTED . . .

How long do you go on playing an Adventure in which you're stuck? Isabel Turner of Ilkeston has got stumped in *Sphinx* and she has been playing it for two years! She can't find the castle or the mouse. I think she deserves a bit of help after all that time — who will gallantly step forward to help a lady in distress?

There are so many mini and main-frame versions of *Colossal Adventure* these days that it is almost impossible

to give help in a lot of cases, as each version has its own peculiar variations. Gordon Scammell of Basildon is playing on a Honeywell which he describes as a "rather naff machine to say the least!" *Colossal* is its saving grace, he says, and asks: how do we open the door with the supposed "walk in" safe and what is the use of the vial? Any other players on naff machines able to help?

Goblin Towers has yielded a wand, necklace, emerald, diamond and sapphire to Katweyn Jones of Co. Londonderry. She's killed a goblin and got a key, but still she and her husband cannot find the remaining treasures. "Are there any smart-arses around who have managed to get them all?" she asks.

How do you escape the Sahara Desert in *African Safari*, asks Nicholas Phillips of Merton Park, how can Andrew Bonser pick the jade flower in *Zim Sala Bim*, and how do you get past the statue of the archer, in *Mystery of Munroe Manor*, asks Ian Harrison of Romford?

Help!! Does nobody know how to get beyond the boat in the *Commodore Quest*? That's a plea from pretty nearly everyone who has played the game — including myself!

Brian Shortland has got expensive tastes! He wants to go up in a lift, but the attendant wants five gold coins which Brian doesn't have! Daylight robbery, I call it — Brian calls it *Ring of Power*.

Peter Billington writes from behind the locked gates in a dungeon in *Castle of Terror*. He just went in and the gate slammed behind him! "I can find nothing here to help me," says Peter, "Can you, please?"

AND HELP OFFERED . . .

Don't forget to turn the page upside down if you have a problem and really want a good clue! Your problem might be answered here! Sharing their good fortune and adventuring expertise with you this month are: Michael Spiteri of Victoria, Australia,

Steven Dix, T. Smith, Adrian Cox (who wins this month's tipster's T-shirt), Owen Davies of Woking, Psi & Temp, Mark Ryan of Manchester, Frank Fearn of Crawley, and Matthew Fletcher of Gloucester.

Strike a light — you're a real charmer!
AFRICAN SAFARI:
 fodder!
 The dinosaur is do-it-yourself cannon
EUREKA (PREHISTORIC):
 lucky!
 The witch would be happier if she felt
EUREKA (ROMAN):
 likes steak
 The Hexapod needs his Mum — he also
KINGDOM OF HAMIL:
 say the magic word
 Wave the wand to cool things down, and
GOLDEN BATON:
 right food?
 rotten! Perhaps he's not been eating the
 The tooth is in the Tiger's mouth, and it is
LORDS OF TIME:
 but you'd better have the sword.
 Touch a rock today if the wall is in the way,
FOREST AT WORLD'S END:
 weapons made in Valhalla
 use the bomb to destroy the idol. Only use
 Give the staff to the man in grey robes and
LORDS OF KARMA:
 RAINBOW and go N.
 up as you go through and at the exit type
 is — W, N, S, S, NW, D, NE, W. Pick things
 The way through the infamous Black Maze
CASTLE OF RIDDLES:
 city to another.
 The blue pass gets you from one ruined
RETURN OF THE RING:
 theless!
 completely successful, but passable, none-
 some of the most important acts may not be
SPIDERMAN:
 cough medicine!
 Ignore the pedlar — his magic cure is a
 night pedestal is useful.
 Moving an urn from a left pedestal to the
MASK OF THE SUN:
 into it.
 To get past the serpent, get the songbird
HEROES OF KARN:
 box. By night he's prowling like a fox.
 Can't find him? By day he sleeps in lock-up
THE COUNT:
 what you remove from it.
 To get into the castle, examine things in the
 null carefully, particularly the ladder and
CASTLE OF TERROR:
 in all directions!
 It's plain to see what to do — look and kick
SORCEROR OF CLAYMORQUE CASTLE:

master of the lamps. another piece of magic from activision.

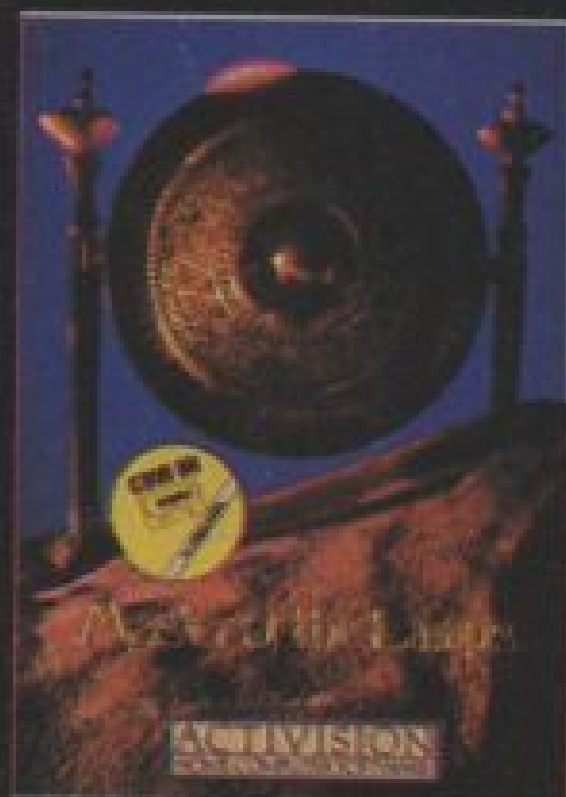

You are the heir to a great fortune. But the crown that was once your father's is almost beyond your grasp. How can you win it back?

First you must fly down an ever-changing corridor in space. Here is flying as it was meant to be. Just you and your magic carpet, flying literally by the seat of your pants.

Reach the end of the corridor and you will meet the first of three Genies who will set you a complex puzzle needing all your skill in colour and sound co-ordination to solve. Do this and the first secret of the lamps will be yours.

But you have only just begun.

Another twenty levels of intense challenge, with no less than seven different musical themes are waiting...

ACTIVISION
HOME COMPUTER SOFTWARE™

At 21.15 hours on the evening of May 16th 1943 a flight of specially prepared Lancaster bombers left Scampton Airfield for Germany. After months of planning and preparation Wing Commander Guy Gibson and his 617 Squadron were at last embarking on a mission so daring that it would guarantee them a place in the annals of history.

The mission would strike at Germany's industrial heartland. If the giant dams of Moshne, Eder and Sorpe could be breached, millions of tons of water would flood the Ruhr, cutting vital water supplies to steelworks and homes, flooding factories, power stations and farmland, and

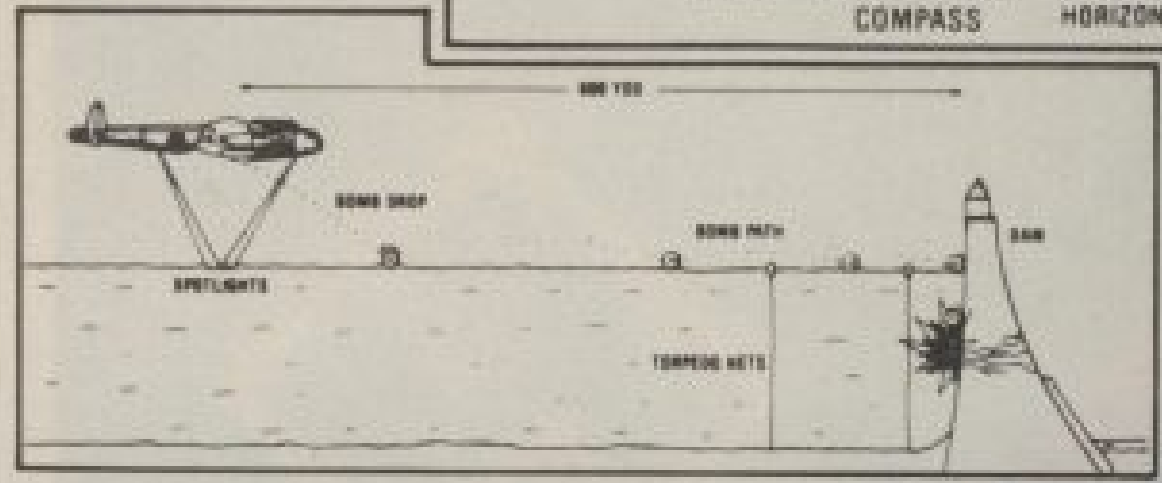
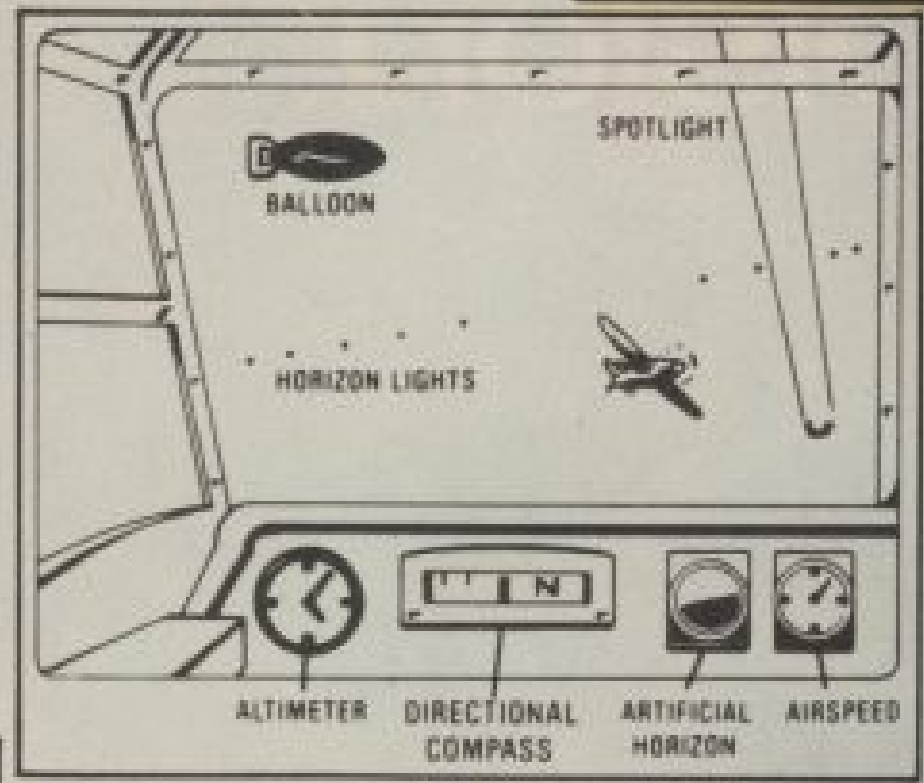

bring the important Mittelland Canal to a virtual standstill.

Of course the successful conclusion of this raid is now legendary, the young men who took part are acknowledged as heroes; and now U.S. Gold in conjunction with Sydney



Development Corporation and the International Computer Group are giving you the opportunity to relive the excitement, tension and drama of this famous mission.

You will be able to play the part of **PILOT**, flying the Lancaster from Scampton to the target, **NAVIGATOR** using screen maps of Europe,

THE DAM BUSTERS



DAMBUSTERS



FRONT GUNNER, REAR GUNNER, BOMBARDIER and FLIGHT ENGINEER.

You will have to fly across Europe at low level to avoid radar; lookout for the deadly ME109 night fighters, dodge barrage balloons, spotlights and flak.

At the target you will need all your nerve and skill to control the aircraft and release your deadly payload at just the right moment while avoiding enemy attack.

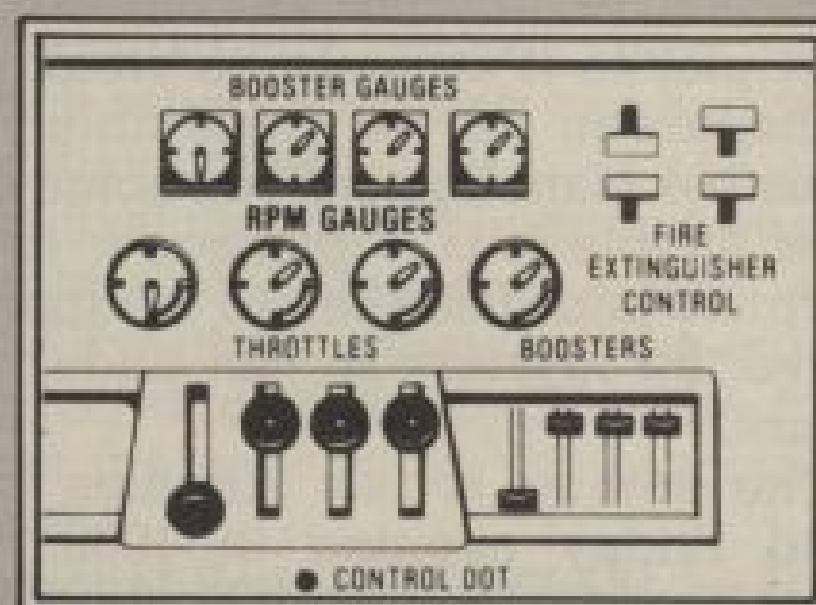

Game Features: **Superb graphics and sound, realistic joystick control, Pilot's screen and indicators, multiple screen navigators maps, front and rear gunners screens, bomb sighting screens, engineer's indicators, and much much more.** The package comes complete with **comprehensive flight instructions, maps, and confidential**

LANCASTER B. MK I/III (DAM BUSTER)

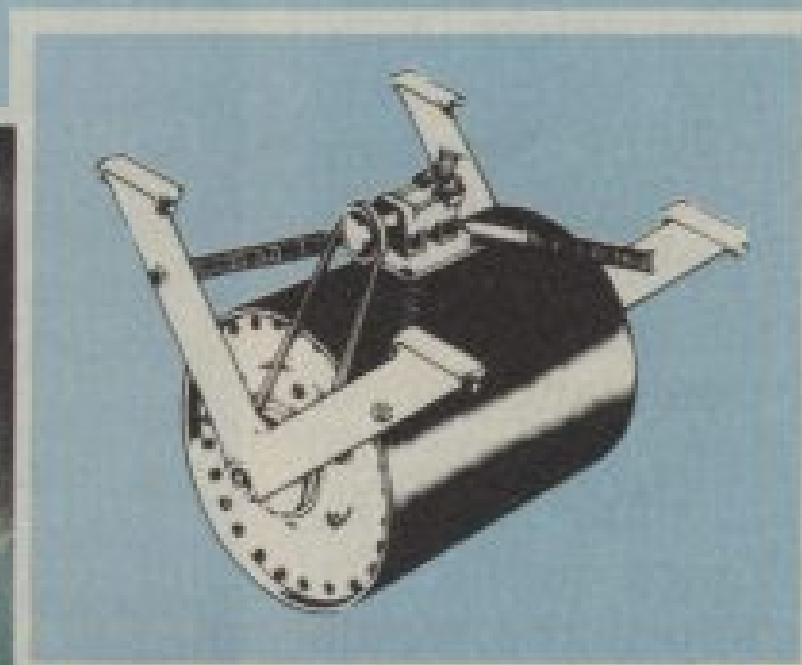
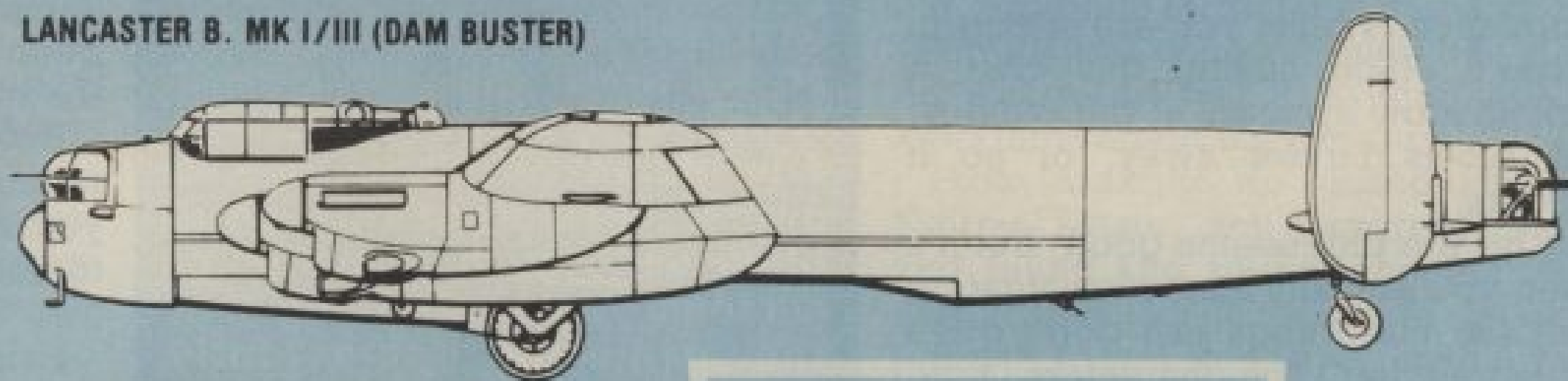

documents including authentic material by Barnes Wallace and Wing Commander Guy Gibson.

Officially endorsed by 617 Squadron of the R.A.F.,

Dambusters is available for **Atari** and **Commodore 64** computers with versions for **Spectrum, BBC** and **Amstrad** coming soon.



U.S. Gold is available from all leading computer stores and selected branches of **BOOTS · W.H. SMITH · JOHN MENZIES · WOOLWORTH · WILDINGS** Dealers! For information on how to become a U.S. Gold stockist contact CentreSoft, Lightning, Microdealer, Tiger and all other leading distributors or write to:
U.S. Gold Limited, Unit 10, The Parkway Industrial Centre, Hensage Street, Birmingham B7 4LY. Telephone 021-369 3020. Telex 337268.

WAKELIN

PAUL'S STATEMENT

It is said that in every barrel of apples there is at least one rotten one, and I have just found Infocom's. Although it retains the usual Infocom style of excellent text and full sentence input, the plot of this standard level detective story unfortunately does not.

In places it appears so weak and transparent as to resemble the Invisible Man. To give you some idea how simple it is, I managed, to my surprise and disbelief, to completely solve the mystery in just under two hours.

The setting is Los Angeles on a cold Friday evening in 1938. You have been invited to the home of a Mr Linder, who claims that his life is being threatened by a Mr Ralph Stiles. You are to establish some basic facts behind Linder's claim.

You gather that some time ago Stiles was having an affair with Linder's wife Virginia who, it is claimed, committed suicide when Linder found out. Stiles is holding Linder responsible and is out for vengeance. Whilst you are sitting in Linder's office having this chat, a dark shadow appears at the window and blows Linder away, or so it appears.

So far the plot seems good, but it's when you actually start investigating the case that things just don't quite come together. The characters in the story number only four, not counting yourself and your sidekick, Sergeant Duffy. This means, of course, that it's not going to take an awful lot of effort to work out who is the guilty party.

The DUFFY HELP command causes Duffy to come straight out and tell you where the next clue is to be found, instead of giving a gentle hint. In my opinion this spoils the whole point of the game which surely must be to solve the mystery yourself.

What is the point of shelling out good money for a puzzling game, if you are given the answer to almost every puzzle by typing just two words?

Personal Rating: 2

Paul Coppins

STEVE'S STATEMENT

It had been a normal day in the office until I received a telegram from some crazy Joe who called himself Linder. He was a hot shot in the business world, plenty of cash and no worries, or so it seemed. But here in my hand was a message sayin' his life was being threatened by a guy called Stiles.

I remembered a newspaper article I had read recently. Yeah! Mrs Linder had committed suicide and she'd been foolin' around with this Stiles guy because her husband had little

REVIEWS



What does our "Personal Rating" factor mean? We use it as a measure of the enjoyment an individual reviewer derives from a game. Because Adventures, like fiction, are so diverse, a reviewer's option is often very much a matter of personal taste, providing that the game is competently presented. As we have a regular team of reviewers, by naming the author of each review, it is hoped that the reader will be able to judge whether a particular game is his or her type. Of course, any particularly good or bad features will be mentioned in the review, in any case.

An illustration of how this works is well demonstrated by two reviews of *The Witness*, a detective Adventure from Infocom. PAUL COPPINS and STEVE DONOGHUE, both well known to regular C&VG readers, have very different views on the game...

time to give her any attention. I picked up my coat and headed off to Linder's house. I had this gut feelin' it was gonna be a long night.

When I arrived at Linder's house, it was the Chinese butler, Phong, who answered the door. I aimed a few sharp questions and was eventually ushered into Linder's office.

Linder sat in a well worn leather chair and beckoned me to take a seat. There was a large window to the rear of the office and a back-door exit. In one corner stood a beautiful grandfather clock. A cat was lyin'

asleep on the floor.

Linder handed me a note: "Read this, it's clearly a death threat by that man Stiles." Sounded ominous — I checked it over for dabs, but no dice. Just then Linder's daughter Monica looked in to say somethin' about going to the movies with her boyfriend. Good lookin' broad, smart with it, as well.

Just as a screech of tyres told me Monica had left, there's this almighty bang and the window explodes, shards of glass flyin' everywhere. When the dust settles, Linder is lyin' dead on the floor.

While I was searching the house, in came Sergeant Duffy, my trusty aide, with a man in tow. "I caught this guy in the woods outside, calls himself Stiles. Says Mr Linder asked him to come over tonight." Duffy handcuffed Stiles to the sofa while I questioned him. This was going to be a piece of cake, I thought.

It wasn't — nothing seemed to fit. As my searching and questioning continued, it became clear that every member of the household had a motive to commit the murder. Somethin' told me that Stiles had been set up. My mind was reeling, the mystery was getting deeper.

But what do you do when the only person to see the crime committed is yourself and you have only 12 hours to find the killer? You see folks, I am *The Witness*.

Personal Rating: 10

Steve Donoghue



EMPIRE OF KARN

The sequel to *Heroes of Karn* is a much snappier game than its fore-runner. Starting off at your place, the *Hall of Callastheon*, accompanied by Darin, thirty-seventh direct descendent of our old friend Beren, you set off to stop your empire from falling. Zheff, the corrupt king of Vorzdeshaa, is plotting your downfall.

Your arrival at Vorzdeshaa enables you to start the main part of your quest and, after trekking across the desert, you come to the capital city, Ivshem.

The text responses are instant, albeit a trifle dense in the presence of such words as EXAMINE and GET. The only response to an unknown word is "Sorry, I don't understand" which gives little help to the player.

On the other hand, I did not find I was groping around for words for too long, so the vocab must be adequate for the plot.

The fact that you can't examine anything, I always think, spoils a game somewhat. On the other hand, there are some multi-word commands which allow you to put things in and speak to the characters you come across on your journey.

The graphics are above average in detail and realism, but just a little slower than some to draw and fill. They are worth watching and they don't become a bore, as they display only on the first visit to a location.

All in all, I found *Empire* very pleasant to play and its music had my foot a-tappin' non-stop!

Empire of Karn is from Interceptor Software for the CBM 64 and Amstrad.

Personal Rating: 9

Keith Campbell

HITCH HIKER'S GUIDE

Before you are put off buying a copy of the game or the book of the TV series by Douglas Adams, let me correct one small point. It does not cost the £5,780,000,004.95 (incl. p&p) quoted, but a mere £34.50 (Atari version). And it does have an advantage over any other form of this great work. You actually get to play the part of the greatest hitch hiker of all time — Arthur Dent.

If you think things are going to be easy because you've read the book, seen it on TV, and heard it on radio, forget it! Douglas Adams, the mind behind the original guide, has joined forces with Infocom's Steve Meretzky, the intellect behind *Sorcerer* and *Planetfall*, to create a totally new game scenario that will delight even the most jaded adventurer. In fact, to be successful in *Hitch Hiker* you must forget all that has been written before and approach this extraordinary Adventure with a clear and uncluttered mind.

The game introduces new concepts into Adventuring which I found to be absorbing, pleasantly amusing and, in one instance, humiliating! I refer to a certain door that defied all the laws of common logic and just refused to open. On consulting the Master for suggestions, Keith only laughed, gloating over the fact that for once I was stuck.

As you play *Hitch Hiker*, you will come across most of the characters to be found in the book. There is Ford Prefect with a satchel full of hitch hiking goodies. Trillian, still as captivating as ever. Zaphod Beeblebrox, as always, in two minds about everything. And, even more self-righteous than in the book, Marvin the Paranoid Android.

There is also a whole host of Sirius

Cybernetics Corporation creations, all with Genuine People Personalities. These include the over-protective shipboard computer, a Nutri-matic drinks machine and some very self-centred doors.

The latter, I discovered to my frustration, won't let you pass through unless you can prove without a shadow of a doubt that you can reconcile totally contradictory situations without going completely bonkers. However, once you have mastered the science of Improbability Physics, you will get the opportunity to play the part of anything from a sperm whale to the president of the galaxy.



There is another unusual feature in this game which really adds to the humour. Let's face it, it's not every day one comes across an Adventure that will lie and argue with you, just for the sheer hell of it!

The guide itself is rather like a database from which you can glean information at any time simply by asking. It even contains footnotes that make good reading in themselves. Mind you, they do seem to have held some rather wild parties in the guide's technical department, the outcome of which was that some entries have been deleted. As a result, no-one can remember where the back-up tapes are kept, nor indeed, if there ever were any!

As with all Infocom Adventures, the packaging contains lots of little extras that add to the fun. With *Hitch Hiker* comes two sets of demolition orders, one on your beloved dwelling, the other, written in Vogon text, orders the total destruction of a little planet somewhere in the uncharted backwaters of the unfashionable end of the western spiral arm of the galaxy.

You also get a Don't Panic button badge, peril sensitive sunglasses (which are impossible to see through!) a microscopic space fleet for attacking microscopic civilizations,

and that all-important, go-anywhere pocket fluff.

The puzzles to be found in the Adventure are somewhat like its humour, that is, as rich and nutty as my mother's fruit cake — and that's great! To solve them you must throw feasible logic out of the window and start thinking in terms of the unthinkable, the seemingly impossible. In a galaxy of improbability drive ships and whacky robots, anything can happen, and usually does!

One final thought. Whoever it was at Infocom that called this a standard level Adventure, should, as the guide itself has declared, "... be the first against the wall when the revolution comes".

Personal Rating: 12,877,431.

Paul Coppins

TRIAL OF ARNOLD BLACKWOOD

Another game for Adventure-starved Dragon owners this month and this time it's from a small company called Nemesis. The game revolves around Arnold Blackwood, a private eye who has been hired by Lord Erebus, but the problem is that he has lost his memory and cannot remember what he was hired for! It is your task to help him regain his memory.

From waking up dazed on the Erebus Estate, you progress round and round and round, and not very easily forward! This game is very difficult to get into, even with a hint sheet! After a few hours hard slog, I managed to amass a fine collection of objects, ranging from a blowlamp to a half-eaten kipper.

On my journeys I met up with a rampaging Triffid, who was no blow over, and the cat Bonzo, who was also a pain. Regular readers will know that The Pink Fairy laughs out loud at such things and sure as taxes I ended up finishing the game with a score of 48%.

It is not necessary to score 100% to complete the Adventure, but if you do you will have had a very hard game. You will have had many more tasks to perform than just the main one which is to return the Gold Amulet to Lord Erebus.

The Dragon has been used to almost its full capabilities, with the character set having been redefined and sound used extensively. If you get to the piano, play it and listen to what makes the Dragon's sound functions so good — it's enough to turn Spectrum owners green with envy!

The Trial of Arnold Blackwood is for Dragon and Amstrad computers, price £4.50 inc p&p, from Nemesis, 10 Carlow Road, Ringstead, Kettering, Northants. I look forward to more Dragon releases from Nemesis!

Personal Rating: 7.5

Simon Marsh

ADVENTURE PLANNER

For a long time now arcade freaks have had joysticks, and hackers have had modems, but there have been no real accessories for the cream of the micro-users, that A-team of the keyboard — the Adventurers!

Print and Plotter, the company that became famous for its graphics planners for the ZX81 and Spectrum, have changed all this with the introduction of the Adventure Planner. This is a tool that no serious would-be hero should be without. It can help you obtain treasure just as easily as it can help to free a beautiful princess.

In the good old days before *Manic Miner* got to Surbiton, the only planner available was a scrap of paper on which to draw a map. In our rush to progress with the Adventure in hand, the map inevitably becomes covered in a criss-cross collection of lines that would need a road planner to unravel.

The Adventure Planner is a large (11 inches by 16 inches) pad of 50 pages, each one of which has over 150 squares, so that your Adventure can be mapped or planned with ease. With the pad comes some useful hints on how to plan and construct maps. It costs £4.50.

Personal Rating: Can I have another one?

Simon Marsh

EMERALD ISLE

Before offering the third part of the *Snowball* trilogy to the world, Level 9 have taken time out to squeeze in a "quickie". Described by Pete Austin as a slightly easier Adventure than their usual style, *Emerald Isle* is £3 cheaper than the rest of the Level 9 range.

The action takes place in and around tree-top cities of wooden buildings, where a contest for the heir to the throne is about to take place. Presumably it is your object to win and take over from the existing king! How you set about this task is a problem in itself, since the rules and conditions don't seem to be around.

But first you must escape the parachute from which you are dangling at tree-top level, for you have bailed out of your plane somewhere over the Bermuda triangle. Once down, you find yourself confronted by a maze of branches, through which you must fight your way to enter the city.

The usual style of Level 9 text is accompanied by what is becoming the familiar look of Level 9 graphics. These are fast to draw and quite pleasant to look at without being exceptional.

There are two commands, WORDS and PICTURES, which toggle the

graphics on and off. I found I needed to use these in a number of locations where the text description was longer than the space below the graphics window. Unfortunately, the words don't stop scrolling when the new message reaches the top line of the text window, so one either has to read very quickly, or type WORDS to be able to follow the descriptions.

I think Pete Austin was being modest when he described this game as easier than usual, judging by the size of the map and number of objects I had amassed compared with my score out of 1,000. All in all, another offering from Level 9 of the high standard we've come to expect.

Emerald Isle is available for BBC, CBM 64, Spectrum, Amstrad, Atari, Memotech and MSX at £6.95 on cassette and for BBC and CBM 64 at £8.95 on disc.

Personal Rating: 8

Keith Campbell

THE PRISONER

Many of the smaller software companies cannot afford large advertisements and tend to go relatively unnoticed. That doesn't mean that their Adventure games are necessarily inferior, as I discovered when I played *The Prisoner*, from Spooft Software.

The Prisoner is based on the television series of the same name and many of the locations in it will be instantly recognisable to followers of the programmes.

The character you assume is No. 6, surely the most famous number ever! You wake up in a village — really a high security prison for ex-secret-service personnel, to ensure they don't spill the beans! From your room, you progress outside where you see many weird things — a statue, a rock boat and a taxi to nowhere!

The first real problem is to overcome your hunger which develops to fatality after 30 moves. Not a brilliantly original trap, but its saving grace is a nearby restaurant where, during the course of a meal, you may come across the Book of the Village. Reading this transports you to some very original problems based on various episodes in the series. On the way to your goal, you are confronted with such things as exploding cricket balls and poisoned ale.

The Prisoner has been written using the Quill plus the new Illustrator. The graphics produced with the Illustrator are just simple line drawings which do not add to the game and, like most Adventures with graphics, a larger vocabulary would have been preferable! On the other hand, good use is made of colour and sound and a new character set has

been created.

I can recommend this as a well thought out and well written game. I hope to see more from Spooft soon!

The Prisoner is for the 48K Spectrum priced £5.50, including postage and packing, and in case you have difficulty in locating Spooft they are at 58 Railway Road, Urmston, Manchester M31 1XT.

Personal Rating: 7

Simon Marsh

NUCLEAR WAR GAMES

Severn Software are well known for their *Mystery of Munroe Manor* and *King Solomon's Mines*. There is something peculiarly frustrating about Severn's games and, in playing *Nuclear War Games*, I think I have got to the bottom of it.

Here, as in the other games, the graphics are very effective and extremely speedy. Sound, too, is used effectively. The problem is the problems!

By that, I mean the player is given no leads, for instance which words are not recognised, nor allowed to carry out actions which would seem logical unless they are part of the one true route to success. Couple with this a slightly "off-track" logic and one soon gives up.

This is a pity, for I think *Nuclear War Games* has some very good points. The presentation I have already mentioned. The plot, too, is interesting. You have to stop a Norad computer from initiating a nuclear war — and it has already taken over control and started the countdown!

Let me give an example of the difficulties I encountered. On a highway running north/south, I am blocked at one end since that leads to Munroe Manor (a nice touch to explain an invalid exit on an open highway!) and, after a few moves south, I am blocked by security gates at Norad. There is a garage en-route which yields various tools and an unmanned army truck further up the road.

After deciding, possibly mistakenly, that I couldn't get through or over the security gate and fence, my own logic suggested that if I drove the truck, the gate might be opened to let me through with no more than a cursory check. In any event, the truck was there for some purpose, so I investigated.

Despite LOOK TRUCK saying YOU CAN'T SEE A DRIVER, I could not ENTER, CLIMB, GO TRUCK or CAB, nor could I DRIVE, START, MEND, REPAIR ... you name it!

Nuclear War Games is for the Commodore 64 from Severn Software.

Personal Rating: 3 (but could improve with time)

Keith Campbell

Super Gran

FREE 16 X 24
FULL COLOUR
POSTER



TT
TYNE TEES
COLOUR

COMING SOON SUPER GRAN
THE ADVENTURE
SPECIALLY WRITTEN FOR KIDS

This great new game is based on the Tyne Tees series Super Gran and produced in association with Tyne Tees Television.

Super Gran will be available for the CBM 64, Spectrum 48K,

C16 and Amstrad on April 2nd with versions for the BBC/B Electron, MSX, Atari and Einstein to follow.

TYNESOFT
COMPUTER SOFTWARE

Ring Tynesoft on (091) 414 4611 for your local stockist.

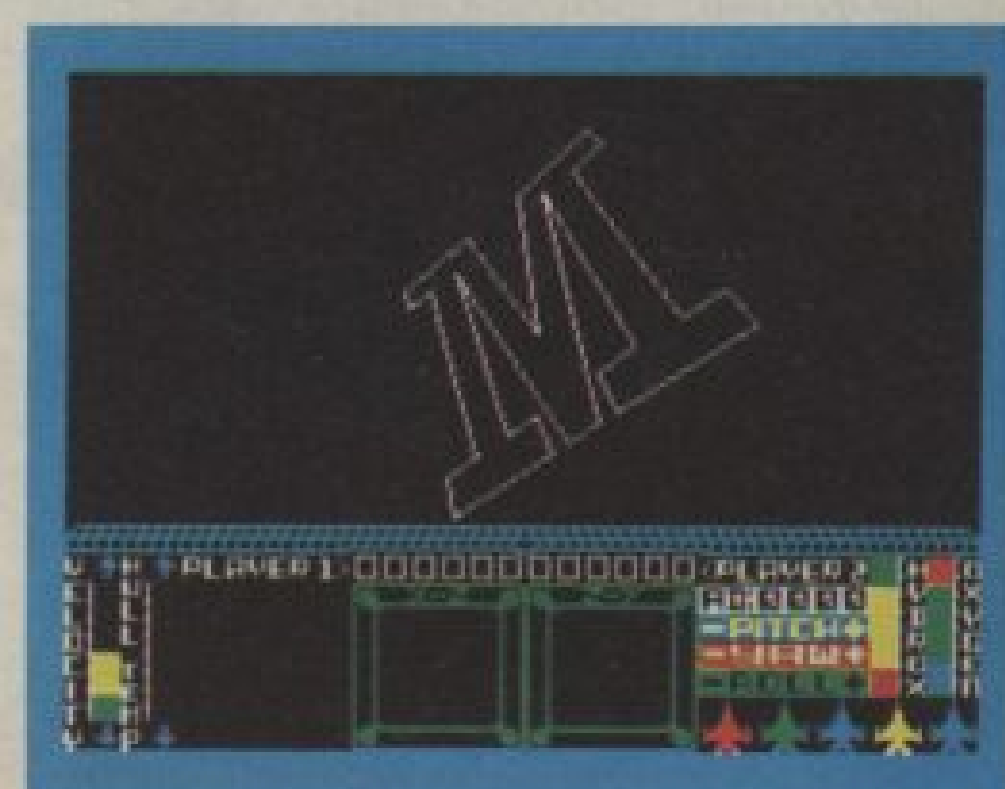
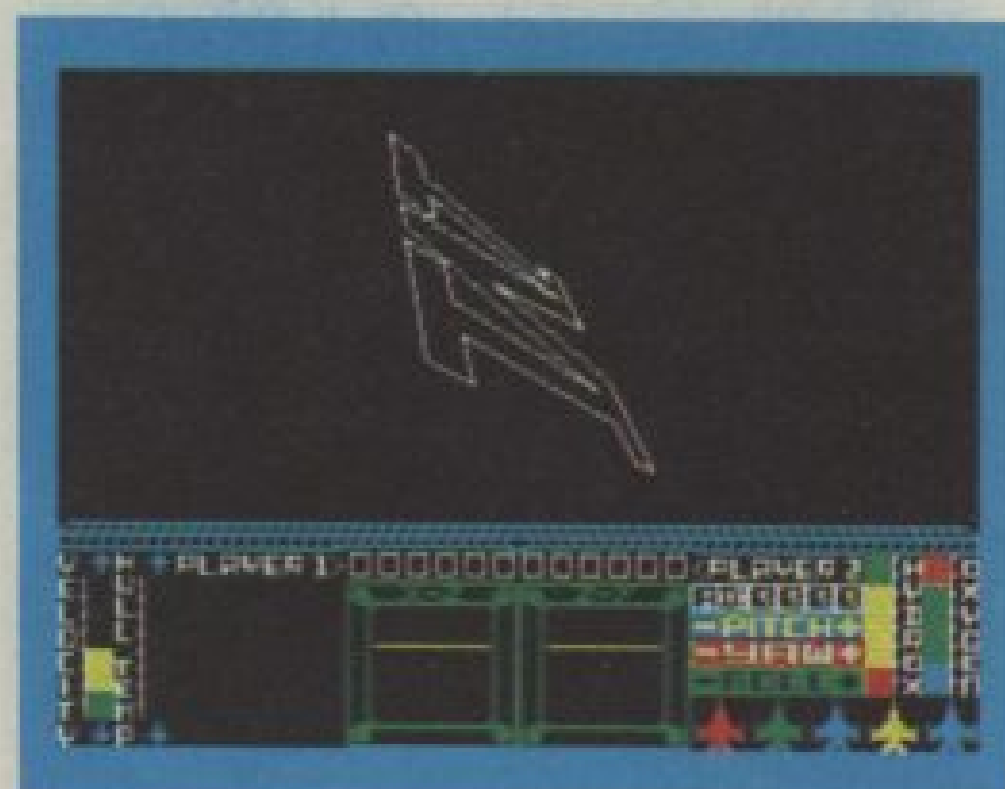
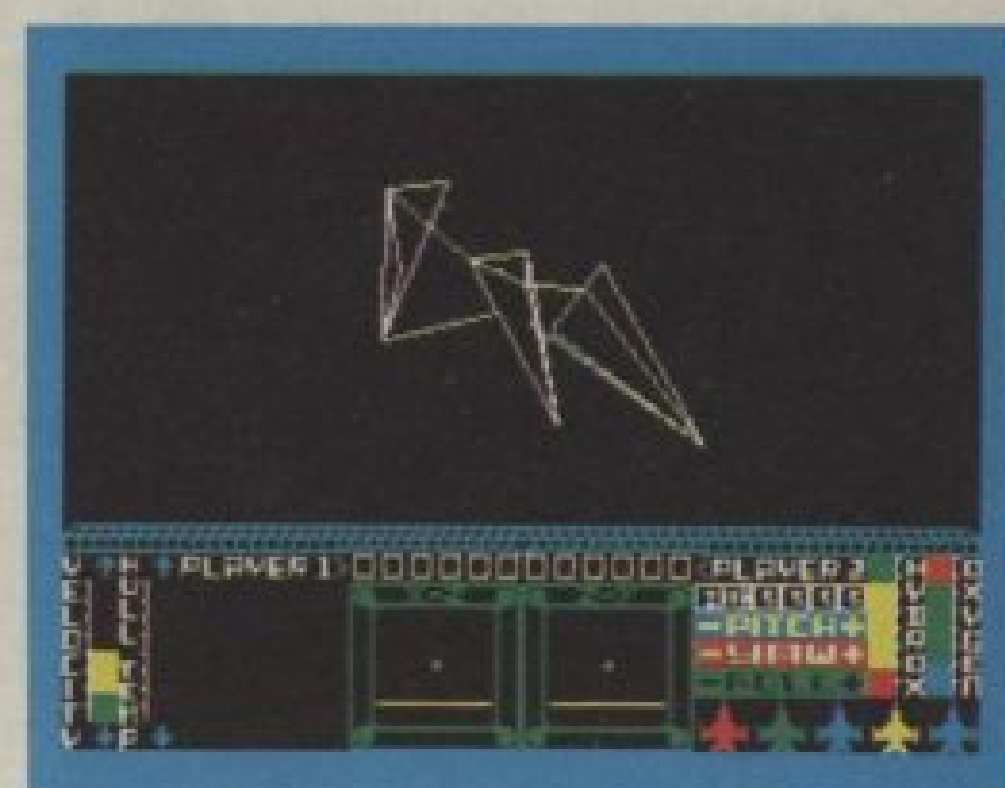
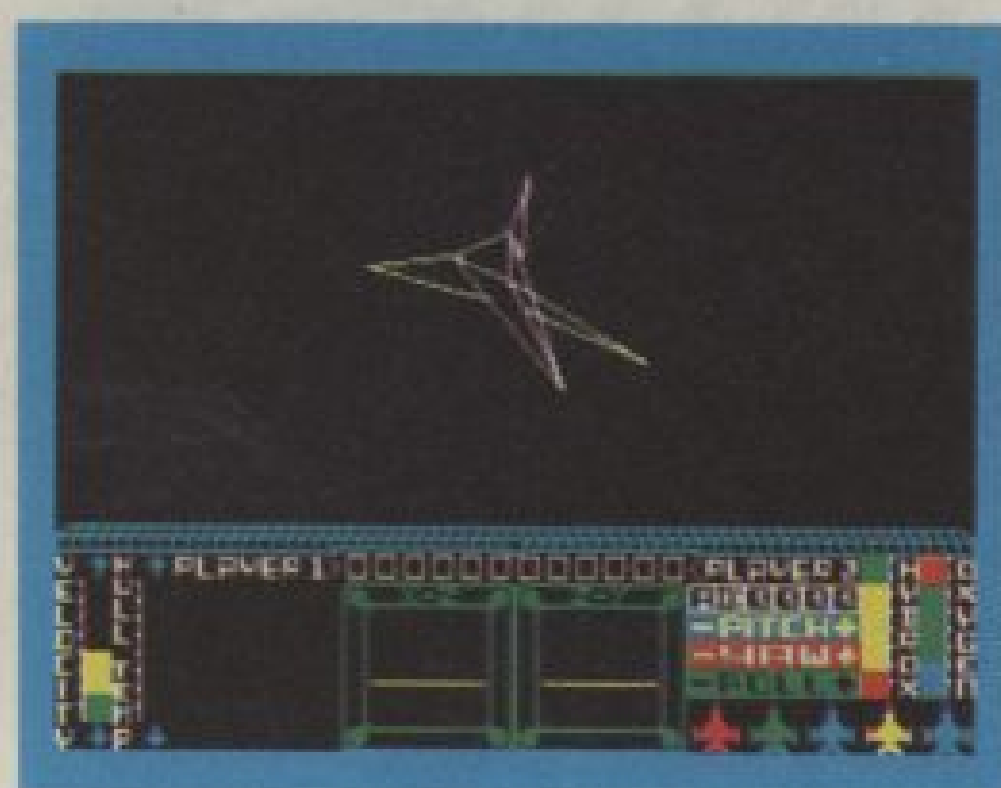
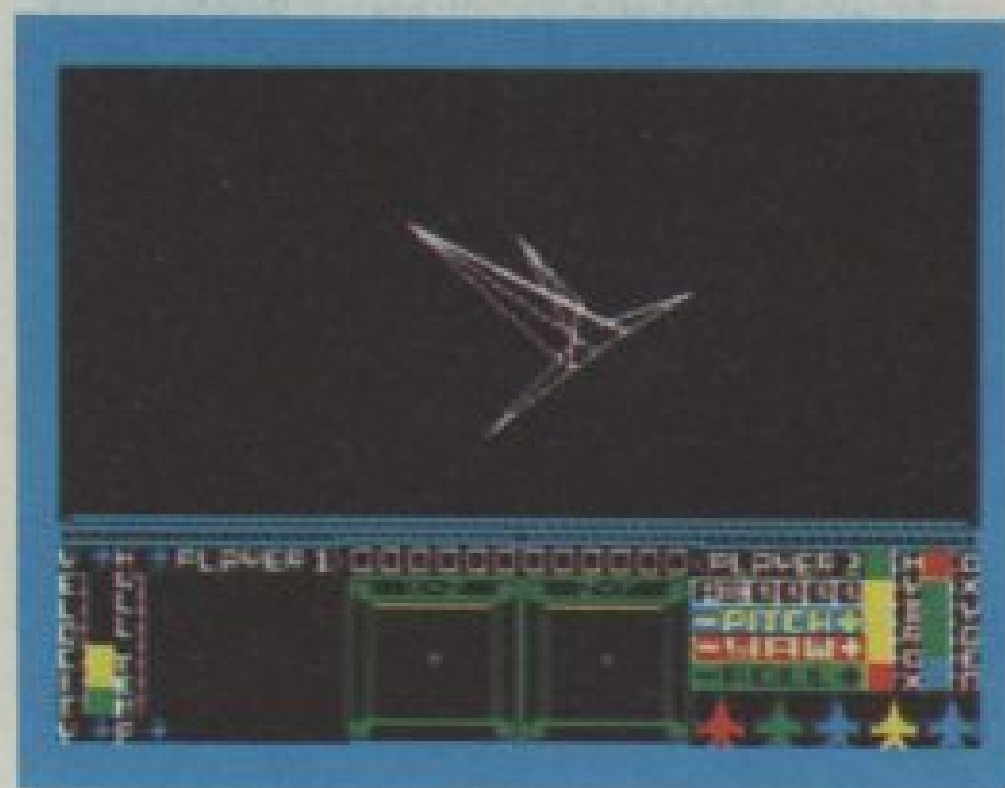
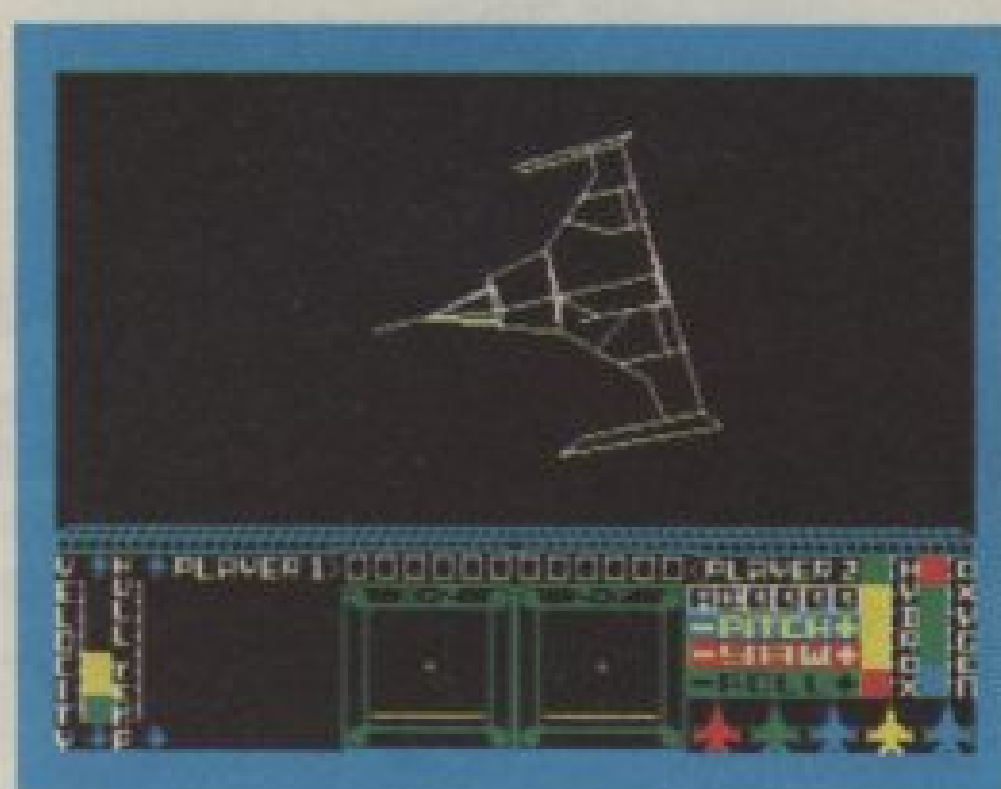
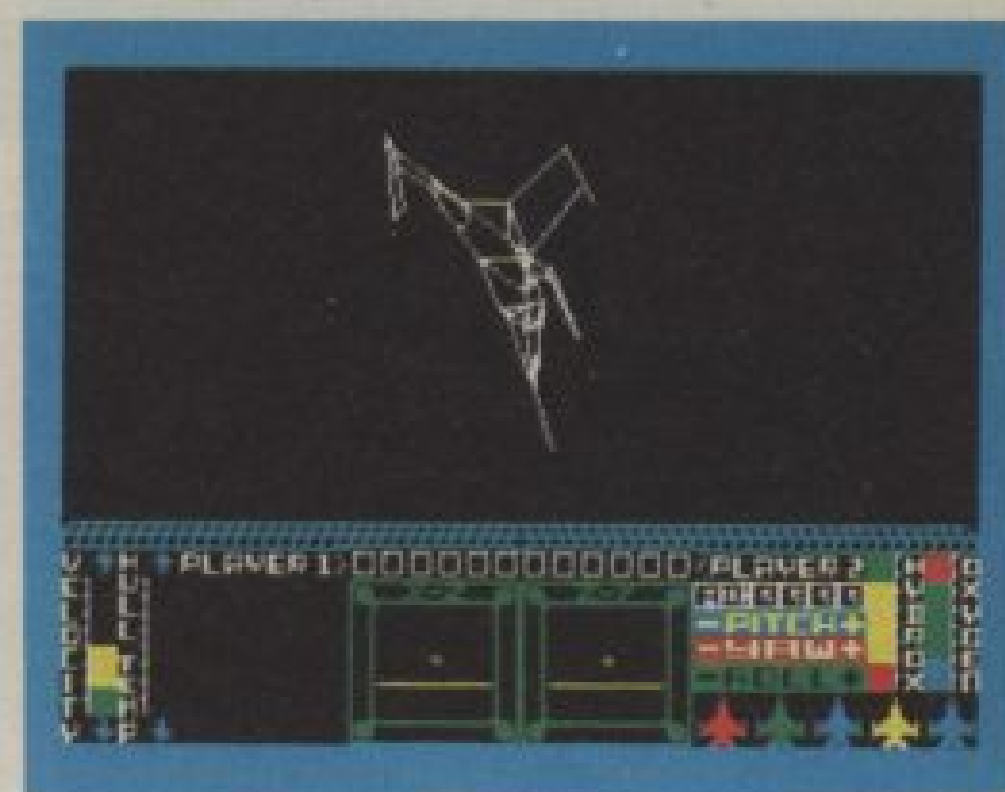
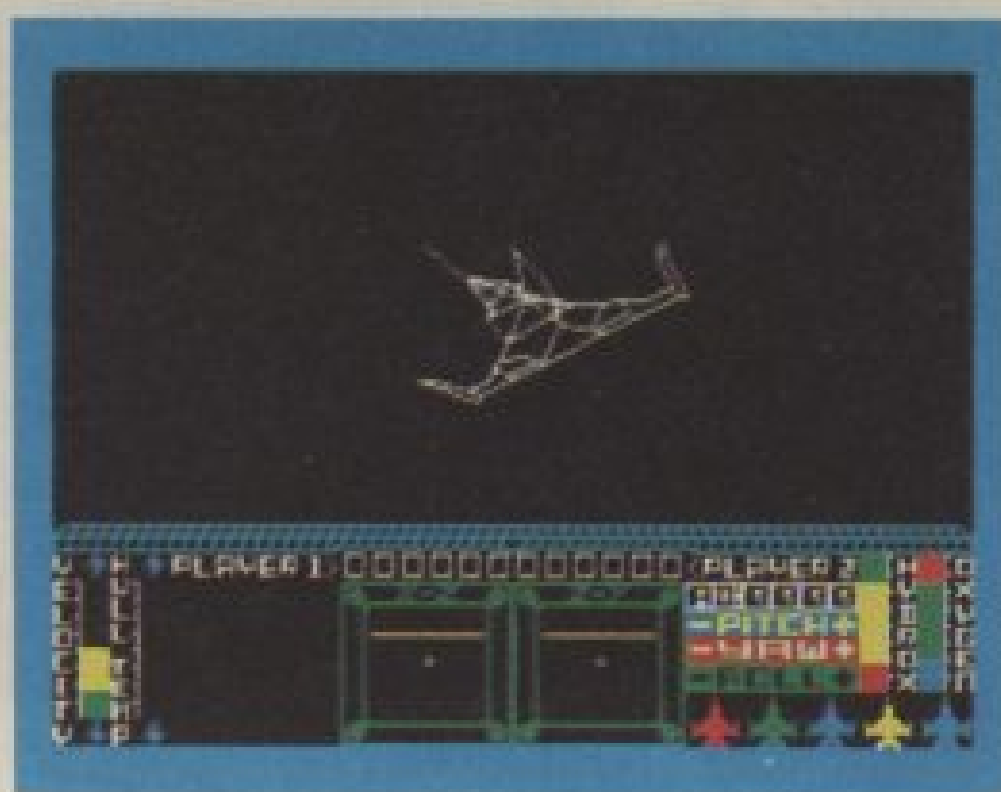
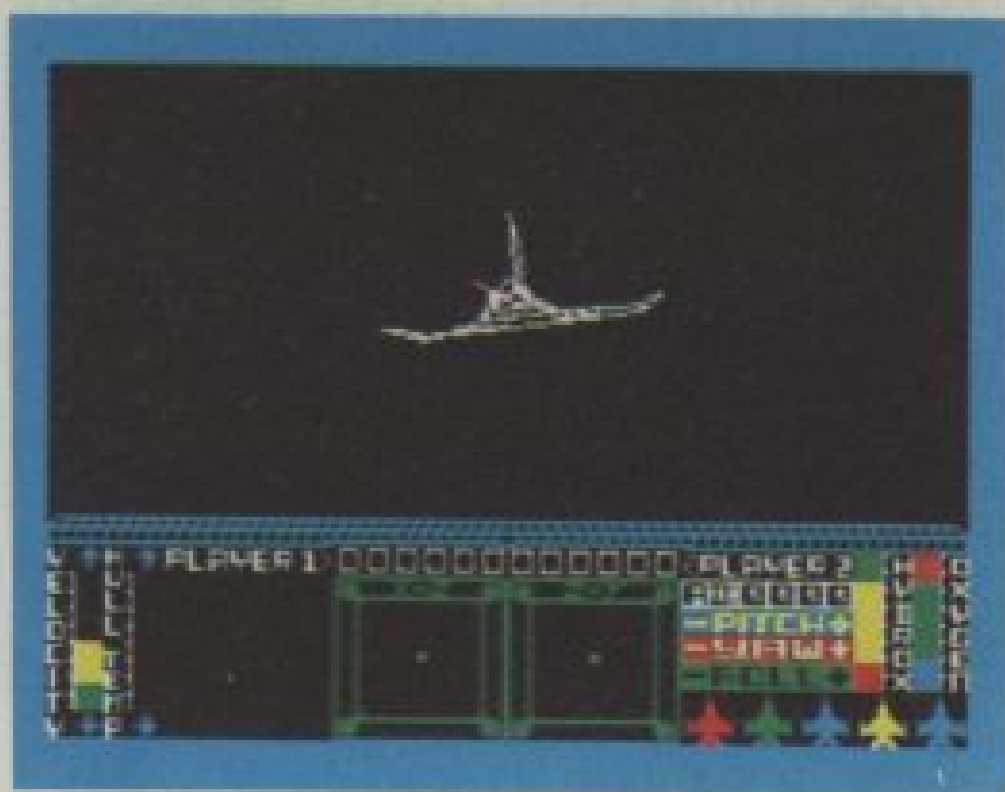

For the 48K SPECTRUM

Arcade space battles, 3D flight simulation, and mind-stretching strategy problems - take on these challenges and become ace space duellist STARION.

As pilot of the world's first space time transmuter, the USS Stardate, your quest is to fearlessly travel through the space time continuum. Recover the secret cargo, a feat which will not only test your fighting skills, but your wits; and escape

through the inter-dimensional timewarp and forward onto another time state.

But be warned! Your dexterity, cunning and combative skills will be tested to the full when battling against the enemy fleets and other hazards you will encounter.

STARION has it all - amazing 3D space action, stunning graphics and high resolution colour. A game of almost unbelievable complexity,

designed to stretch your Spectrum beyond its limits to undreamt of capabilities.

Don't just play it, experience it!

STARION is available for your 48K Spectrum and Spectrum+ at £7.95.

Barclaycard and Access orders can be accepted on our 24 hour ansaphone, just call (0235) 83 5001.

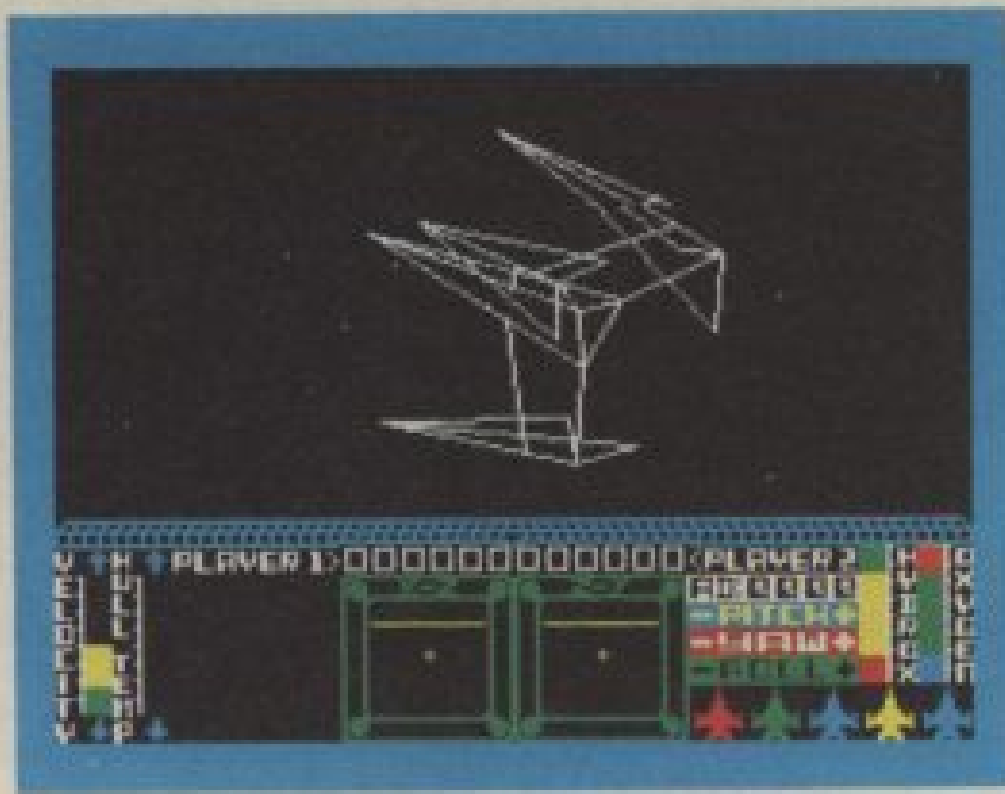
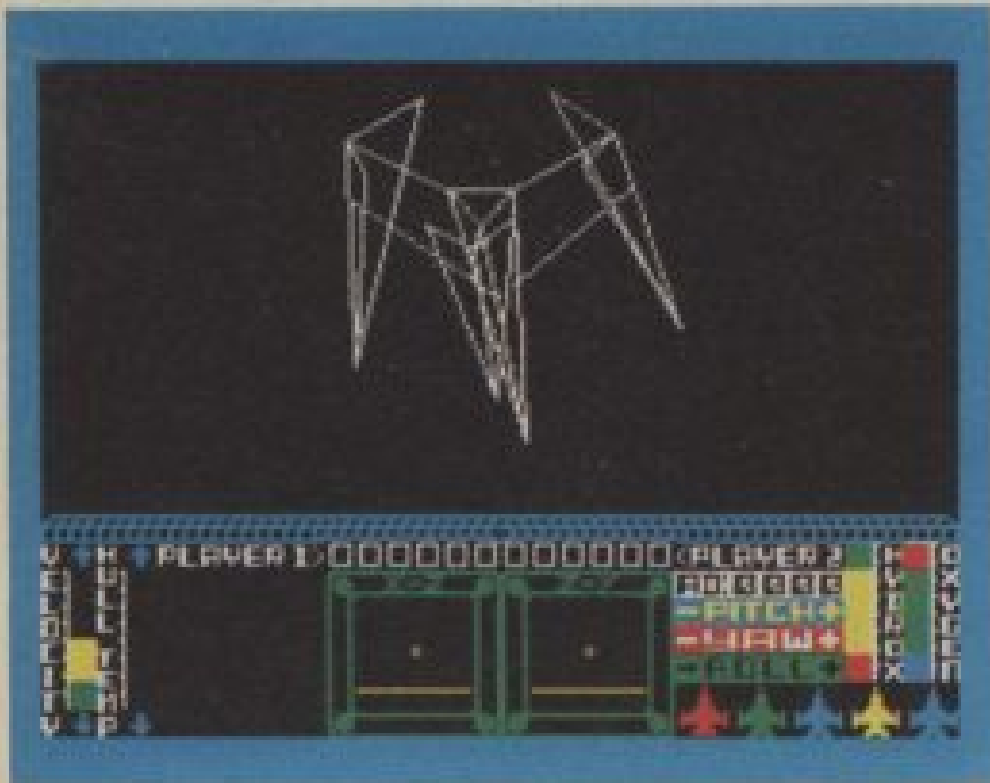

**Thrilling
space
battles**

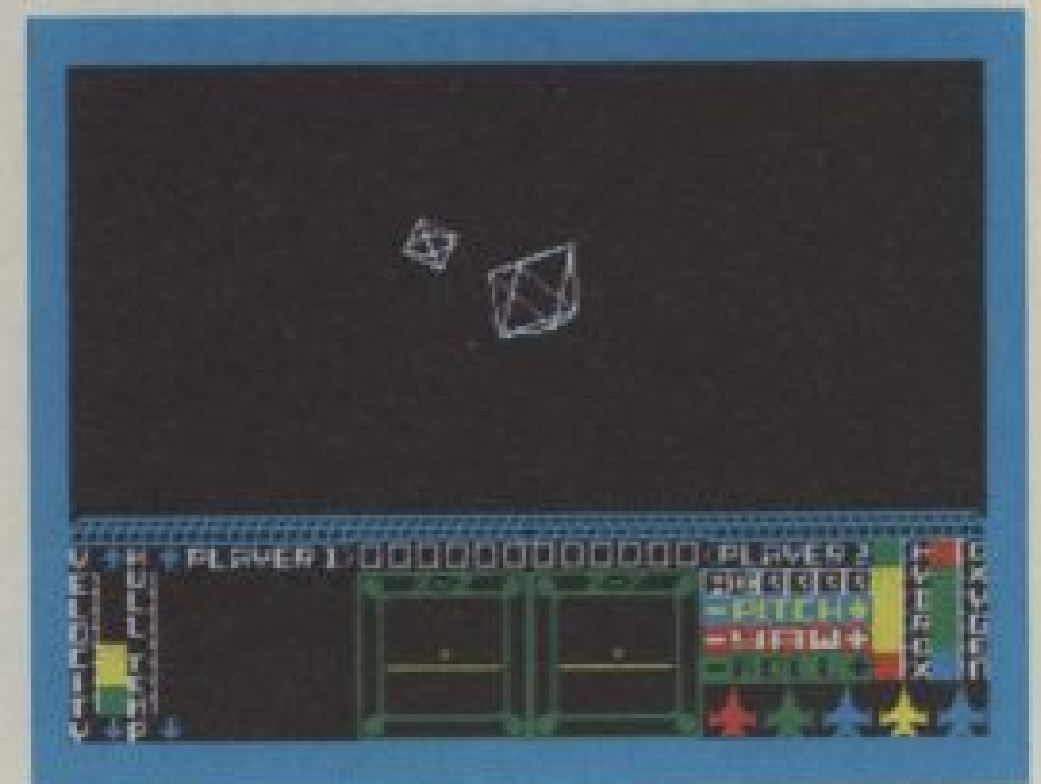
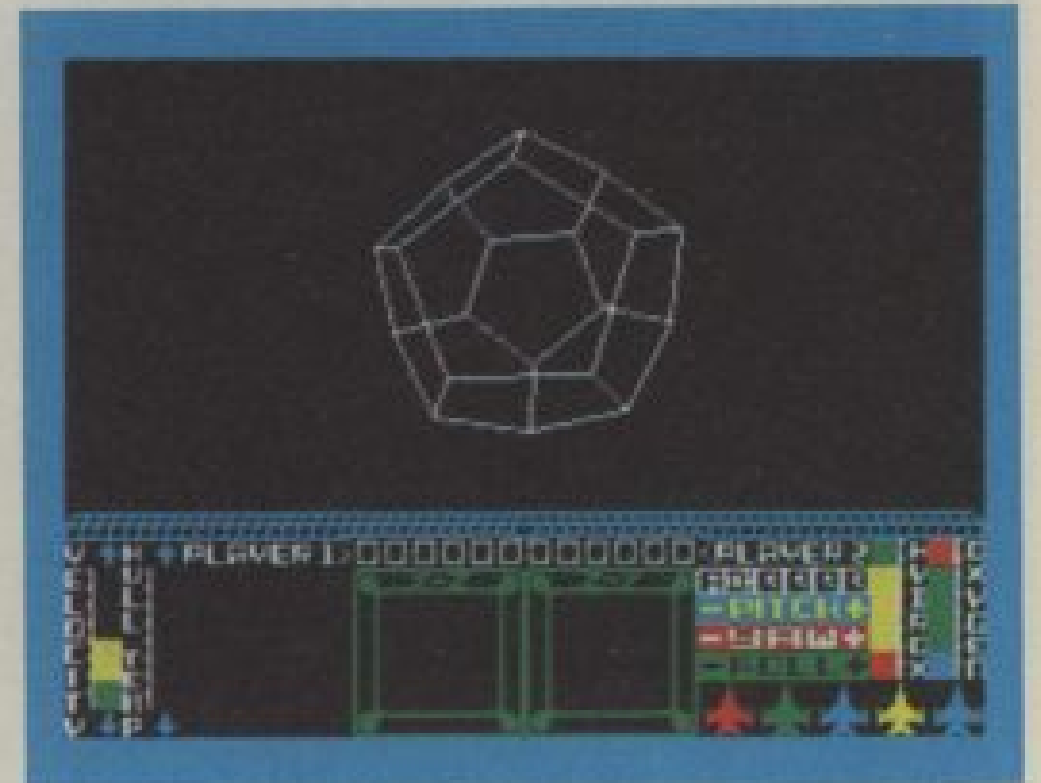
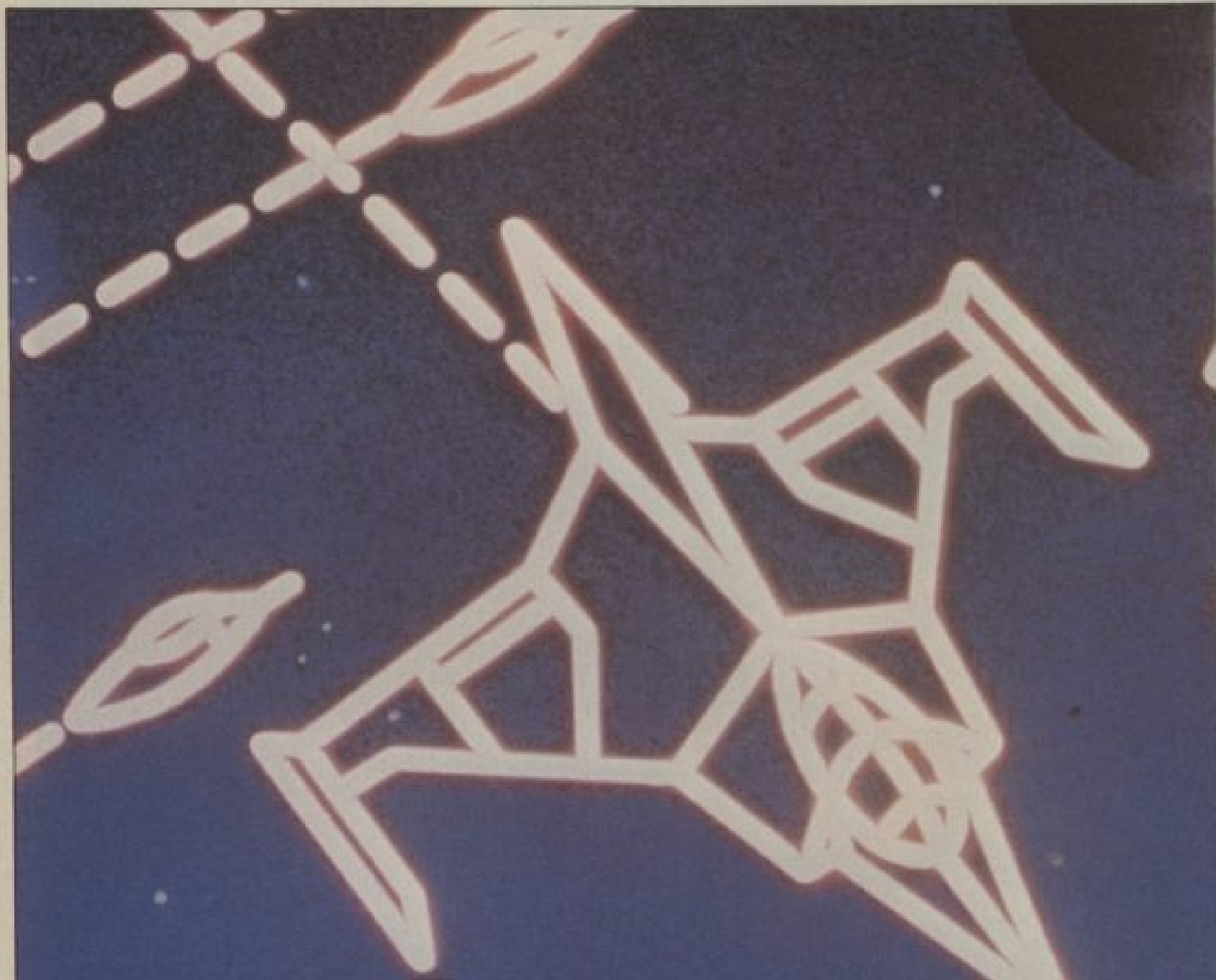

STAR ORION

From Melbourne House



BEYOND

CHALLENGING SOFTWARE

Now for
Spectrum 48K
and
Commodore 64

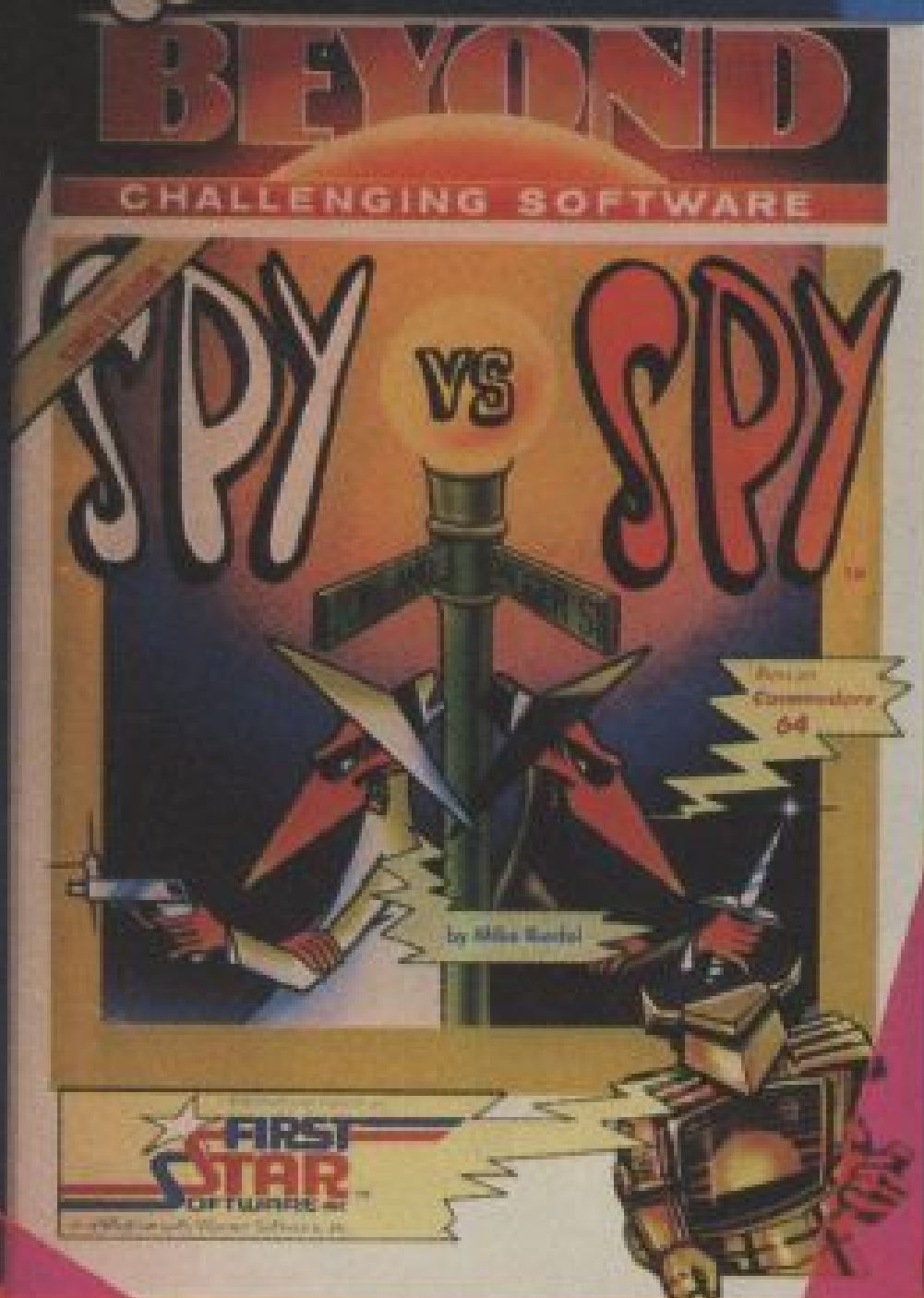

Spy vs Spy is two player cartoon fun!
The black and white spies chase each
other around the embassy.

They steal secrets and plant
traps, playing against each
other on a split screen display.

Available from software dealers everywhere or direct from
Beyond Competition House, Farndon Road, Market Harborough, Leicester LE16 9NR.
Access/Barclaycard telephone: 0858 34567. **Price £9.95** inc. P&P

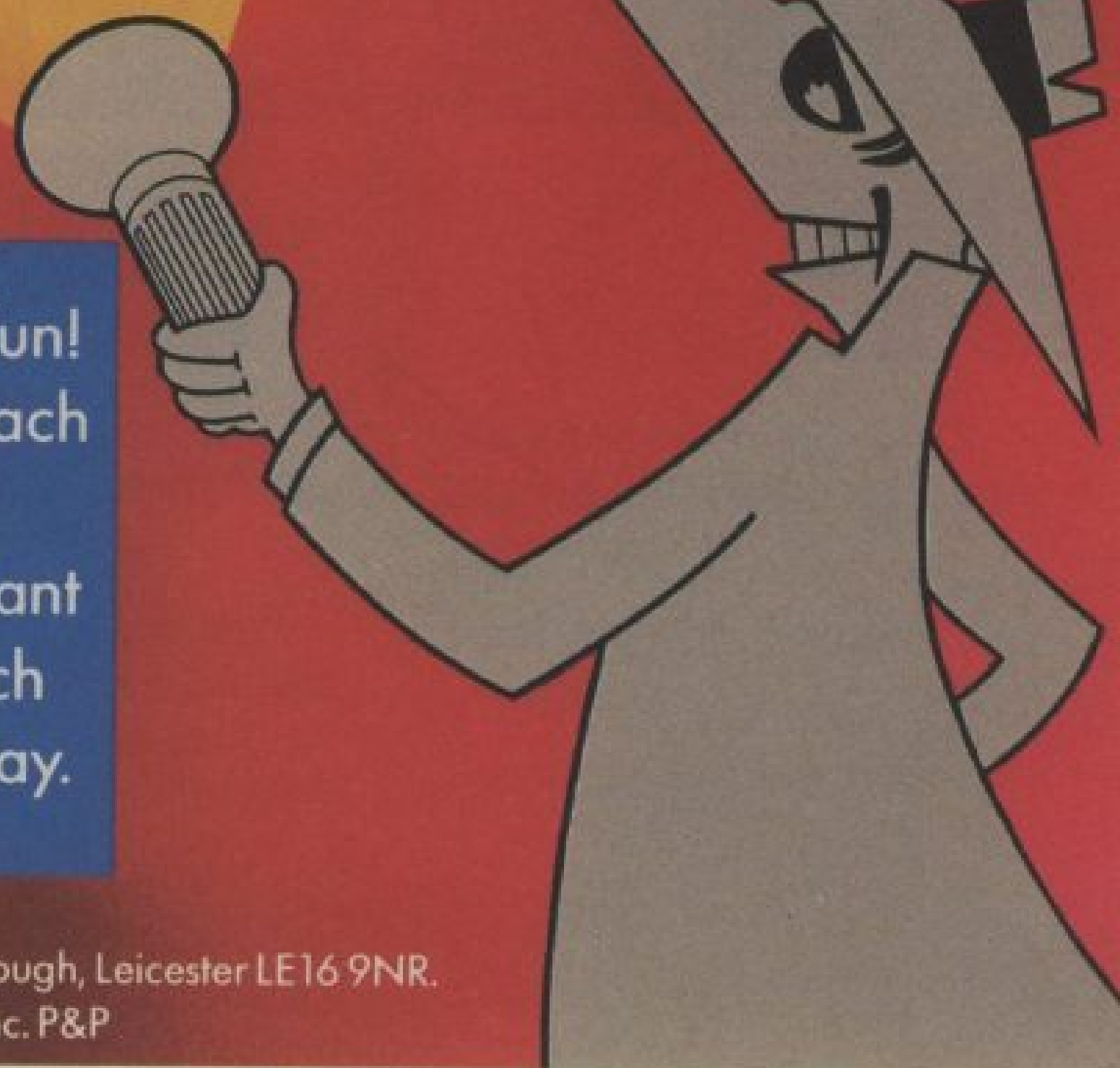



SOFTWARE WORLD

12 ETHEL STREET, BIRMINGHAM B2. TEL: 021 643 7559
FOR ALL POPULAR MICRO HARDWARE, PERIPHERALS & SOFTWARE

Birmingham's largest stockists of:
AMSTRAD, ATARI, COMMODORE, DRAGON, ELECTRON, MSX, ORIC, SPECTRUM AND TEXAS



**SOFTWARE AT
AMAZING PRICES!**
(i.e. Atari from £4.00)

**ATARI COMPUTERS
800XL/1050 DISK DRIVE PACK**
inc. Home Filing Manager
Pay off: Text Adventure
Sound & Graphics Demo
£249.99

800XL/1010 RECORDER PACK
inc. Pole Position
Inv to Programming
Sound & Graphics Demo
£129.99

800XL COMPUTER
inc. Joystick, Pacman
£99.99

ALL LATEST ATARI SOFTWARE INCLUDING
V.C.S. CARTRIDGES, IN OUR NEW 1ST
FLOOR ATARI CENTRE

SEND S.A.E. FOR FREE LISTS
(SPECIFY MACHINE)

ATARI BOOKS & MAGAZINES

ANTIC
ANALOG
PAGE 6
ATARI USER
(inc BACK ISSUES)
PLACE YOUR
REGULAR ORDER
WITH US NOW
MANY ATARI BOOKS
IN STOCK

PLEASE PHONE TO CHECK STOCK AVAILABILITY
BEFORE SENDING MONEY - REMEMBER
IF WE DO NOT HAVE WHAT YOU REQUIRE IN STOCK
WE CAN NORMALLY 'OBTAIN IT' FAST!
U.K. & AMERICAN SOFTWARE IS AVAILABLE
MAIL ORDER U.K. POST FREE (EXCLUDING BOOKS &
MAGAZINES). GOODS DESPATCHED BY RETURN
POST, SEND FOR UP TO DATE LISTS

BACK IN STOCK

Atari Technical Ref. Notes	17.00
De-Re Atari	17.00
Atari Roots	17.20
Your Atari Computer	17.50

ATARI STOP PRESS!

M.P.P. PRINTER I/FACE	69.99
R-VERTERS 232 I/FACE	59.99
U.S. DOUBLER	79.95
(converts 1050 to d/d)	
MINOR MIRACLES WS MODEM	149.99
MINER 2049'er (cart)	17.95
BOUNTY BOB STRIKES BACK (cart)	49.95
GHOSTBUSTERS (disk)	14.95
DROPZONE (c/d)	9.95/14.95
POLE POSITION (c/d)	9.95/14.95
MR. DO (c/d)	9.95/14.95
SPIDERMAN w. GRAPHICS (d)	17.95

ATARI SELECTED CARTRIDGES

e.g. STAR RAIDERS, PAC-MAN £8.50 each
£15.00 for two please
£18.00 for three phone

MEGASAVE FANTASTIC SAVINGS

SPECTRUM	
Kong Strikes Back	5.90
Alien 8	8.50
Skooldaze	4.95
Sam Stoat	5.85
Star Strike	4.95
In Dam Trouble	5.85
Air Wolf	5.95
Underwilde	8.50
Knight Lore	8.50
Doomdark's Revenge	8.50
Combat Lynx	7.85
American Football	8.50
Ghostbusters	8.75
Shadow Fire	8.50
World Baseball	5.95
Zombie Zombie	5.85
Pyjamarama	5.85
Fall Guy	5.95
Sabre Wolf	8.25
Beach Head	6.95
Lords of Midnight	8.50
Football Manager	5.85
White Lightning	12.50
Dev-Pac 3	10.50
Tasword II	11.75
Hampstead	8.50
Match Day	6.85
Blue Max	6.85
Gift from the Gods	8.50
Hunchback II	5.80
Monty's Innocent	5.85
Death Star	6.85
Zaxxon	6.85
Raid over Moscow	6.85
Everyone's a Wally	8.50
Duke's of Hazzard	5.85
Software Star	5.85
Technician Ted	4.95
Brian Bloodaxe	6.85
Project Future	6.00
Airwolf	5.50
Quill	11.25
Illustrator	12.50
Emerald Isle	5.85
Buggy Blast	4.95
Toy Bazaar	6.85
Tapper	6.85
Spy Hunter	6.85
Bruce Lee	6.85
Subterranean Striker	5.85
Soft Air	4.95
Flak	6.85
Quick Shot II plus interface	18.50
Flightpath 737	6.85
Brian Jacks	6.85
Gremlins	8.50
Day in a Life	5.85
Komplex	8.50
Wizards Lair	5.85
Gyron	8.50
Formula 1	6.85
Grand National	5.85
Stay Cool	5.85
Fantastic Voyage	5.85
Chockie Egg	5.85
Confuzion	5.85
Dragontorc	6.85
Mighty Magnus	5.85
Mega Hits	16.00
Minder	8.50
Starion	6.85
Rock 'n' Bolt	6.85
911/TS	6.85
Frankie Goes to Swords and Sorcery	8.50
Automan	6.85
Rocky Horror Show	8.75
Buck Rogers	6.85
Moon Cresta	5.95
COMMODORE	
Staff of Kamath	8.50
Indiana Jones	8.50
Conan the Barbarian	8.50
Zaxxon	8.75
Hunchback II	6.95
Give my Regards	6.85
One on One	8.50
Bungleing Bay	8.50
Choplifter	8.50
World Baseball	6.85
Quo Vadis	8.75
Everyone's a Wally	8.50
Cliff Hanger	6.85
Football Manager	6.85
Beach Head	8.50
Pole Position	8.50
Emerald Isle	5.85
Penetrator	5.95
Slap Shot	7.85
Software Star	6.85
Tri Na Nog	8.50
Shades	7.85
Gryphon	6.85
Frak	7.85
Impossible Mission	7.85
Knightmare	6.00
Lords of Midnight	8.50
Automan	8.00
Stella 7	8.50
Buck Rogers	6.85
Soft Aid	4.99
Up and Down	8.50
Super Huey	10.50
Dough Boy	8.50
Talladega	8.50
Pacman	8.50
Mr Do	8.50
Dig Dug	8.50
Dark Tower	6.85
Aimazz	8.50
Mama Liama	6.50
Brian Jacks	7.85
Gremlins	8.50
Fistful of Fun	8.50
Rocket Ball	6.85
Mega Hits	16.00
Pipeline II	7.75
Grand National	6.85
Airwolf	6.85
Pitfall II	7.85
Kong Strikes Back	6.90
Archon	8.50
Front Line	5.85
Flyerfox	6.85
Gandalf	6.85
Joust	6.85
Ciphoid 9	8.50
Pastfinder	8.50
Rock 'n' Bolt	8.50
911/TS	6.85
Aqua Racer	5.85
Music Studio	12.50
Bounty Bob	8.50
Skull Island	12.50
Murder Water Front	12.50
Confuzion	5.95
Frankie Hollywood	8.50
Blagger Hollywood	7.95

Postage included UK. Please state which micro. Fast Service.
Send cheque/PO to: MEGASAVE, Dept. CVG, 76 Westbourne Terrace,
London W2

DORCAS
SOFTWARE

NEW
RELEASE

THE RUNES OF ZENDOS

This fascinating animated graphic and text
adventure game with the challenging RUNIC
PUZZLE is now available for:

AMSTRAD CPC464

As well as for the 48K Spectrum. Its many
features include:

12 different adventures,
full sentence input,
continuously displayed graphics.

"Addictive" - Micro Adventurer (Jan 85)

"A very fine game" - Crash Christmas
Special

"Compulsive fun" - HCW (Jan 1985)

Available from Boots and other leading
retailers or direct from:

DORCAS SOFTWARE
3 THE OASIS, GLENFIELD, LEICESTER

PRICE: £7.95 inc. p&p

**NEXT
MONTH**

Get ready to change up to top gear for next issue's very special *Pitstop II* competition. You could be at one of this season's Grand Prix races thanks to CBS and *C&VG*! So grab your skid-lid and prepare to qualify for the June issue of *Computer & Video Games*. You'll need to be quick to catch a copy...

* * *

Hello John, got a new game? Find out about how Mr Daley and our Tel got tangled up in the software business in your favourite computer magazine. 'Er indoors won't like it at all!

* * *

Find out all about the people who put the word special into special effects in blockbuster movies like *Tron* and *The Last Starfighter*. And it's definitely not all done with mirrors...

* * *

C&VG's special agent has been going undercover to bring you the inside story on the new James Bond game *A View to a Kill* — with some EXCLUSIVE pictures of the game. Discover some secrets next issue.

* * *

Solve the mystery of Electric Software's *The Wreck* and win yourself an MSX computer. Worth getting your feet wet for!

COMPETITION RESULTS

Did Morkin destroy the evil Shareth with the Ice Shards in your version of *Doomdark's Revenge*?

If you successfully completed the three "Fighting Fantasy" episodes based around Beyond's best-selling game *Doomdark's Revenge* in the December, January and February issues of *Computer & Video Games*, the three questions should have caused no problems.

In part one, we asked which treasure of Luxor's was the most valuable. The answer was The Crystal Ball which allowed Luxor his first glimpse of his adversary.

Part two asked which of Tarithel the Dreamer's three Fey runes was the most useful in her quest to find Morkin. The answer was the rune of the Sun — it is the only spell which would defeat Shareth the Heart-stealer in her guise as a wolf.

Part three requested that you find the most useful of Morkin's three magical possessions. The Cup of Dreams was the best as it allowed Morkin to revive the all-important Dragon.

There are 20 copies of Beyond's *Lords of Midnight* awaiting the winners. This first of the Midnight trilogy, by *C&VG* columnist Mike Singleton, featuring 32,000 screens of action, independently moving enemies, treasures, traps, dark lords and wizards has just been converted to the Commodore 64.

For Spectrum owners who already have *Midnight*, we can offer *Doomdark's Revenge* for the winners.

Ian Drury, Ashford; Colin Roger, Aberdeen; M Eaden, Sheffield; M Bagshaw, Staffs; Ian Greener, Hereford; W M Chua, London; David Naylor, Leeds; Geoffrey Herher, Worcestershire; Clay Willing, Aylesbury; A Wales, Northwich; M Bergh,

Enfield; Tony Jeffries, Kent; Richard Johnston, Banffshire; I Murphy, Liverpool; Andrew Paynter, Wrexham; Vincent de Sanctis, Luxembourg; M J Davies, Dyfed; Stephen Jones, Chester; R Price, Cornwall; Paul Goodman, London.

20 people are going to help Alex Rogan — The Last Starfighter — save the universe and their Survival Kits will be winging towards them very shortly.

In the meantime here are the names of the winners: Shaun Wong, N Humberside; Neal Addison Leeds; Adam Parry, Stevenage; Karen Saxton, N Yorkshire; Stuart Douglas, Hull; Martin Knespel, Vienna; Andrew Davies, Clwyd; Hans Lauring, Denmark; Darren Rutherford, Co Durham; Christopher Carr, Preston; David Collins, Bournemouth; Jason Stevens, Broxtowe; John Palmer, Louth, Barry Pope, Cheshire; Conrad Lucas, S Wales; Robert Crowther, Leeds; Neil Punton, Fife; John Adams Powell, London; Richard Wilkinson, Epsom; Justin O'Brien, Eastbourne.

The three winners of our February crossword are: Miles Chidlow, Gwent; David Alan Biggs, Co Durham; Andrew Hulcoop, Cornwall.

There will be a slight delay in the arrivals of the T-shirts as we are awaiting a new batch in the office but, don't despair lads, they will arrive.

A couple of months ago we asked you to send in your ghost stories, and 50 winners would win a copy of the *Ghostbusters* game by Activision. Next month we'll be printing a couple of the best. So watch this space! PS. Could Darren Broughton, one of the winners, please send us his full address?

RAPID ROUND-UP OF NEW RELEASES

AMSTRAD Amsoft	Centrecourt Detective Survivor	C16 Melbourne House	Games Pack I Games Pack II Roller Kong Flight Path 737
Anirog Solid Software Amsoft	The House of Horrors Splat Blagger Pyjamarama Classic Racing Dragon's Gold Software Star	Anirog	
Addictive		DRAGON Design Design	Rommel's Revenge
ATARI English Software	Atari Smash Hits 1, 2 & 3 Colossus Chess 3.0	MSX Activision	River Raid Pitfall II Hero Beamrider Mr Wong's Loopy Laundry
BBC Visions	Apple Pie Hubert	Artic	
BBC & ELECTRON Kosmos	Identity Europe	ORIC/ATMOS Severn Software	Chopper
		VIC 20 Interceptor	Villain

The art of making music.

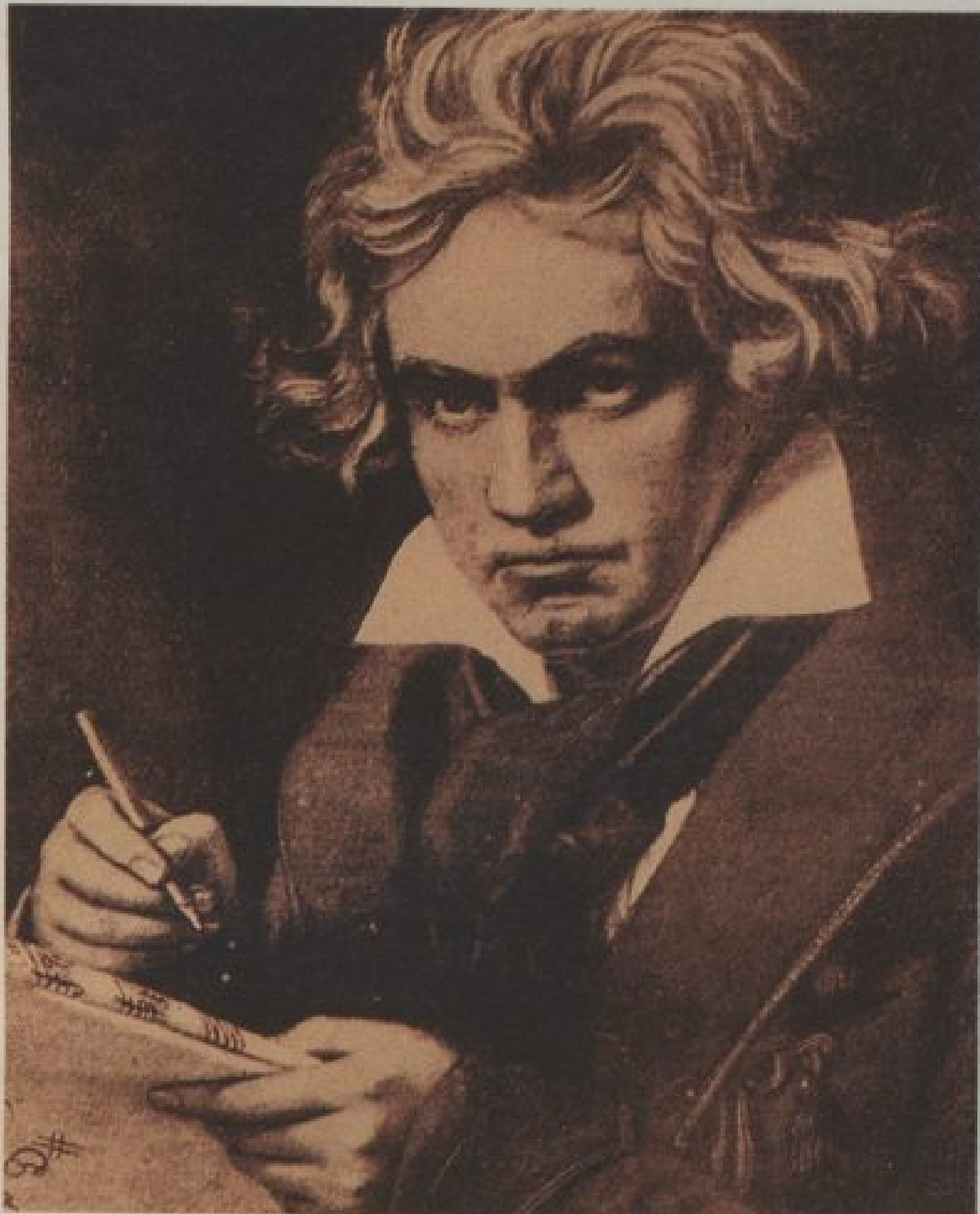

The old way.

How many of us have the feeling that if we could only write down music in the same way that we can write words, there would be no holding us.

Well, now you can.

With Activision's Music Studio.

Note by note, you can build a melody from the music in your head. And see it on your TV screen as well as hear it.

You can add harmonies.

Lyrics. Change key. Change tempo. Change instruments (from a choice of 15 including keyboard!) You can scroll the melody through the TV screen and then print out the result.

You can do all this with your computer and a joystick.

If, musically, you're a beginner, don't worry. Music Studio

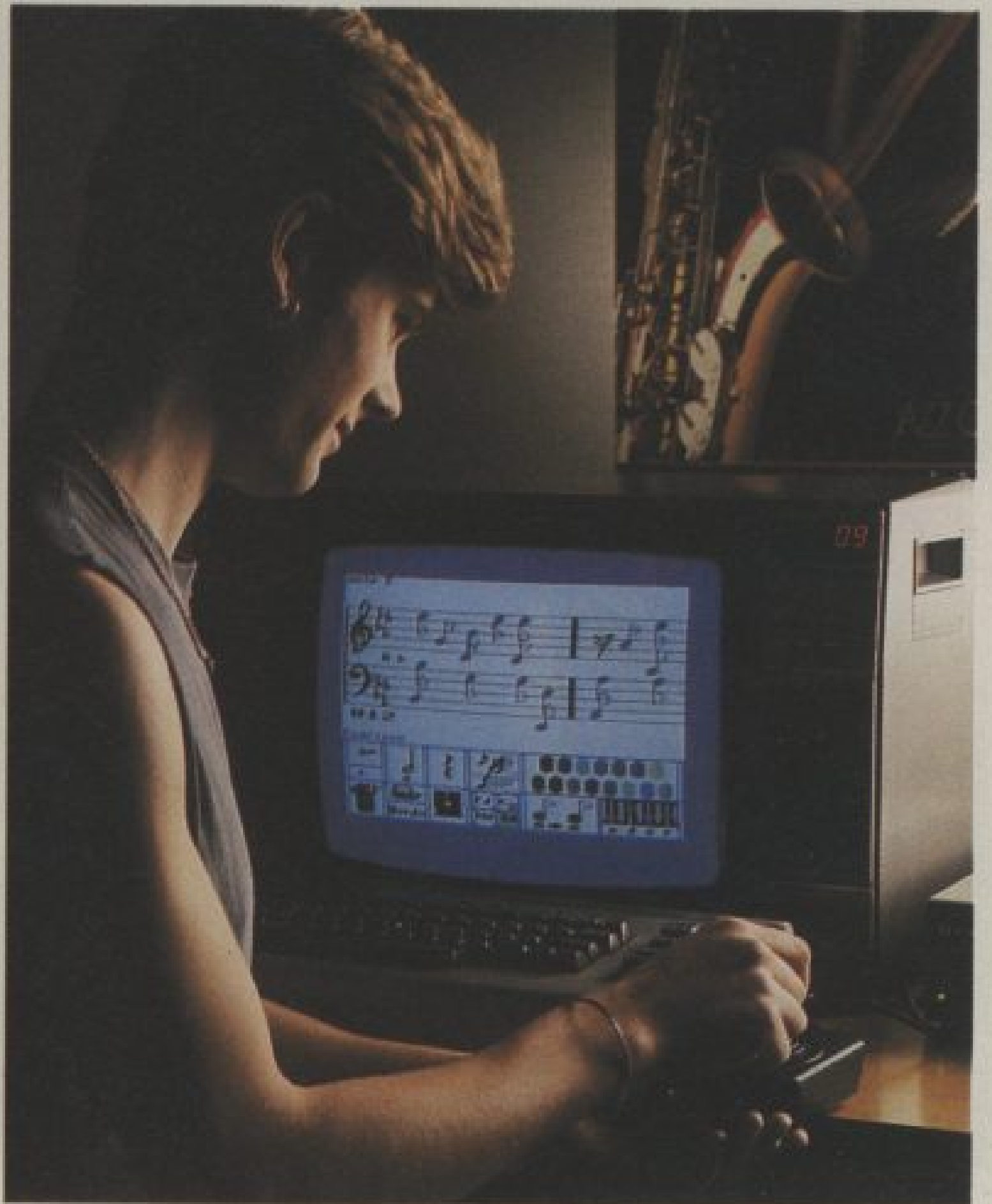

The new way.

will help you create your own sounds, step by step, with no previous knowledge of music whatsoever.

There's even a menu of fifteen assorted melodies, ranging from Ravel to Joplin, for you to experiment with. (Try scoring Mapleleaf Rag for Keyboard and Steam Train. It takes two seconds with Music Studio!)

If you are a musician, you'll wonder how you ever lived without the Music Studio.

If you're not a musician, you soon will be.

£14.99 for the cassette and £19.99 for the disk from all good software stores.

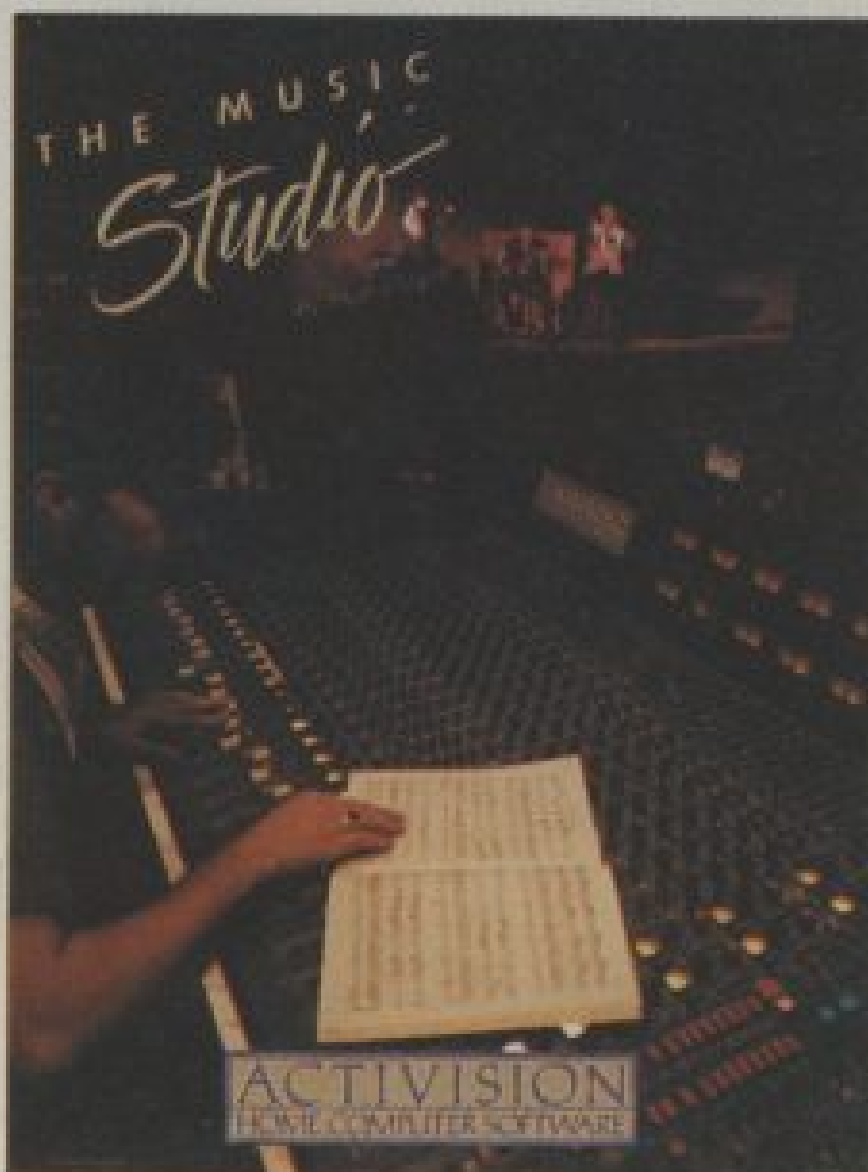

ACTIVISION
HOME COMPUTER SOFTWARE™

FROM SELECTED BRANCHES OF BOOTS, WH SMITH, JOHN MENZIES, LASKYS, SPECTRUM, RUMBELOWS, WOOLWORTH AND GOOD COMPUTER SOFTWARE STORES EVERYWHERE.

BEYOND

CHALLENGING SOFTWARE



WE'VE DESIGNED AN ADVENTURE
AND DESTROYED THE TEXT!

SHADOWFIRE
USES PICTURES NOT WORDS
TO ISSUE COMMANDS.

SHADOWFIRE

COMING SOON FOR SPECTRUM 48K
AND COMMODORE 64

INCENTIVE

CONFUZION

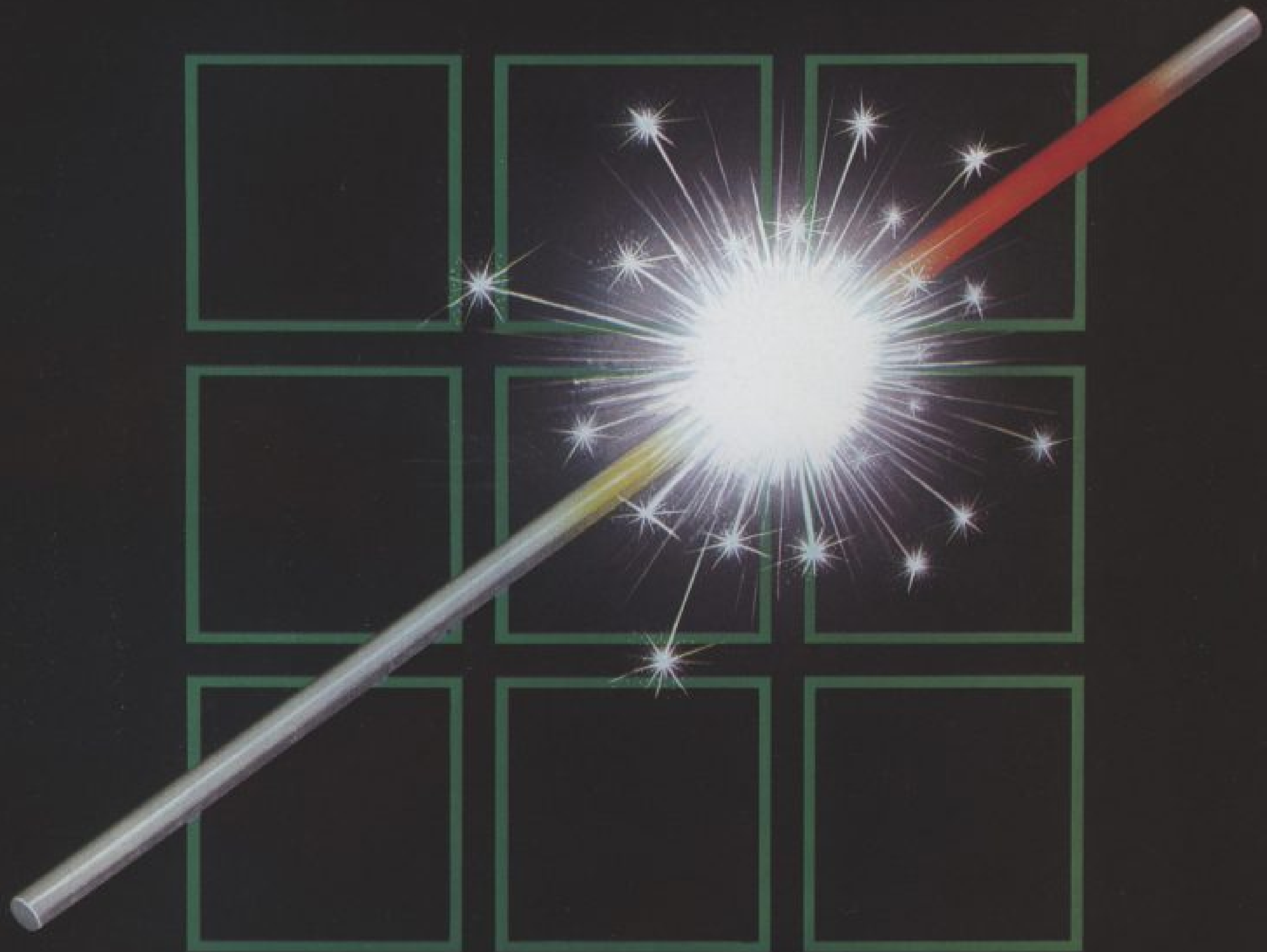

THE FUZION OF MIND AND MACHINE

★ AMSTRAD ★ SPECTRUM ★ COMMODORE 64 ★ BBC B ★ ELECTRON ★

Price £6.95 Trade and Credit Card orders: Telephone (0734) 591678

INCENTIVE, 54 London Street, Reading RG1 4SQ

SUPER SKETCH

A Remarkable Innovation in Video Graphics

Until now, creating computer graphics in colour has been both a demanding and expensive endeavor. The Super Sketch Graphics Tablet provides a totally unique and simple medium for creating video graphics at a surprisingly low cost.

By simply moving the stylus control arm, as you would a pencil, Super Sketch reproduces the movement on the video screen. Four control buttons at the top of the tablet assist in operating the graphic functions of the software. Graphics may be created by "free hand" or by "tracing" from drawings clipped to the pad.

Compared with other computer graphic products, it is much easier to use than keyboard controls, does more than joysticks, paddle controllers and mouse controllers, and is less expensive than touch pad products.

A brief demonstration instantly proves the remarkable features of Super Sketch. This product makes an excellent "Demo Display" in retail stores because anyone can immediately produce graphics with little or no instructions.

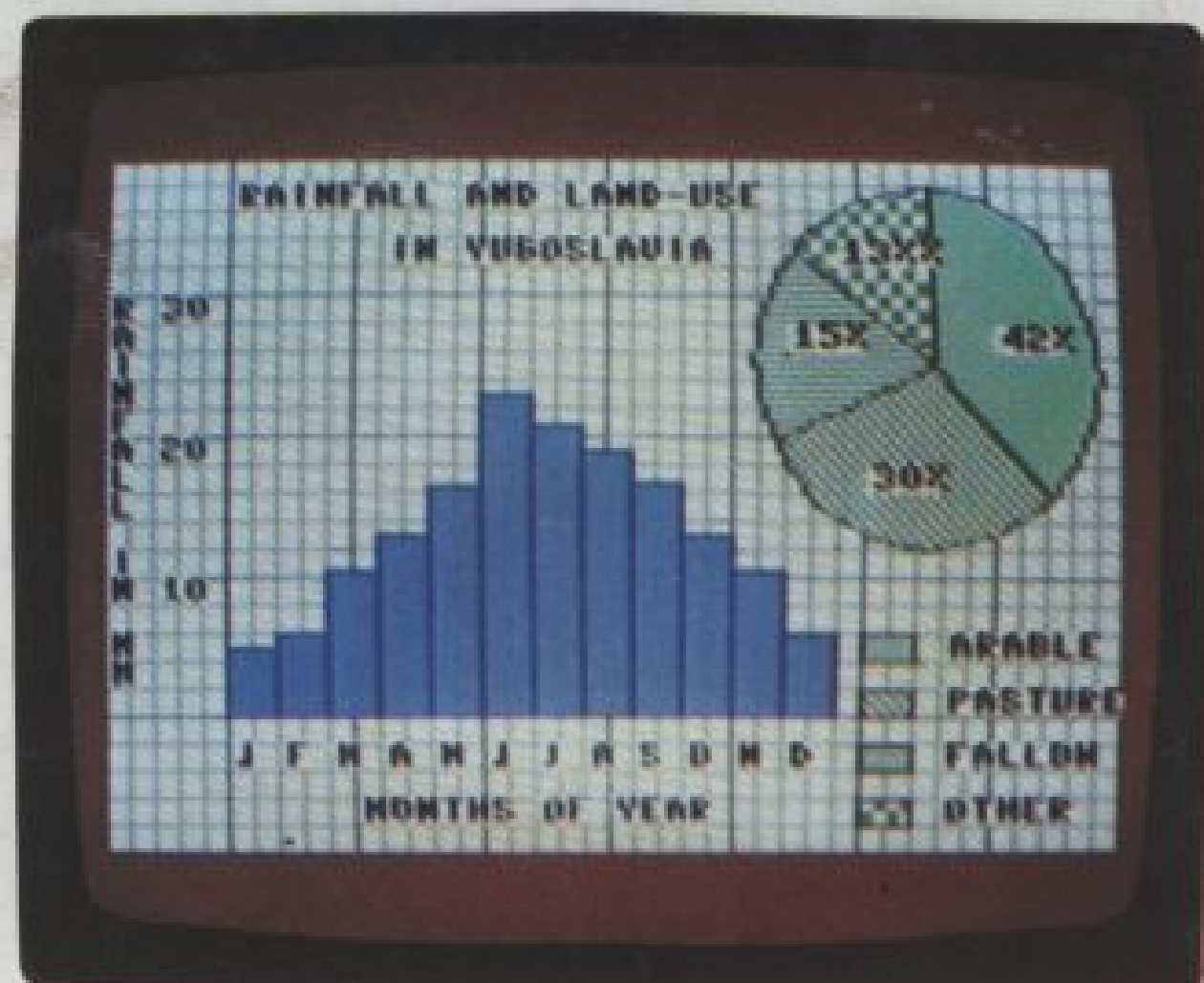

NOW £49.95

The graphic above was created using the Super Sketch Software

- Creates Super Video Graphics
- Absolutely Simple To Use
- Cassette Software Included
- Printer Utility Included
- Starter Kit Included



- Cassette Software Includes Printer Utility and Starter Art Programs
- Four Easy To Use Menus: Main, Brush, Design, Expert
- Custom Brush & Design Capability
- Keyboard Text Entry Capability
- Tracing & Free Hand Drawing On One To One Ratio To Video Screen
- Easy To Use Push Button Controls
- Graphics Can Be Saved To Cassette And Reproduced On A Printer
- Zoom Window

Compatibility	Screen Resolution	Color Selection	Unit Dimensions (In Gift Box)
Commodore 64	160 x 200	16	16 1/2" x 12 1/4" x 2 1/2"

ANIMADOG

Trade Enquiries
Unit 10 Victoria Industrial Park, Victoria Road, Dartford, Kent DA1 5AJ Tel: 0322 92513/8