

# ACE

■ ST ■ AMIGA ■ C64 ■  
CPC ■ SPECTRUM ■ PC  
■ NINTENDO ■ SEGA ■

## THE ULTIMATE GAMES MAGAZINE

### ADVANCED COMPUTER ENTERTAINMENT

## SIM EARTH EXCLUSIVE

First playtest of the extraordinary successor to Sim City

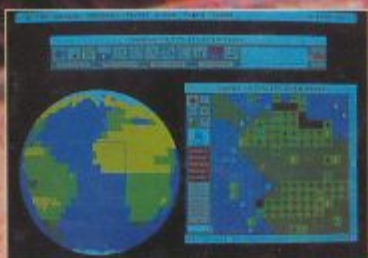

### MOVIES IN YOUR MICRO

Interactive games from Sierra On-Line and Dynamix

# WIN

a trip to

# HOLLYWOOD

and the set of

## BACK TO THE FUTURE II

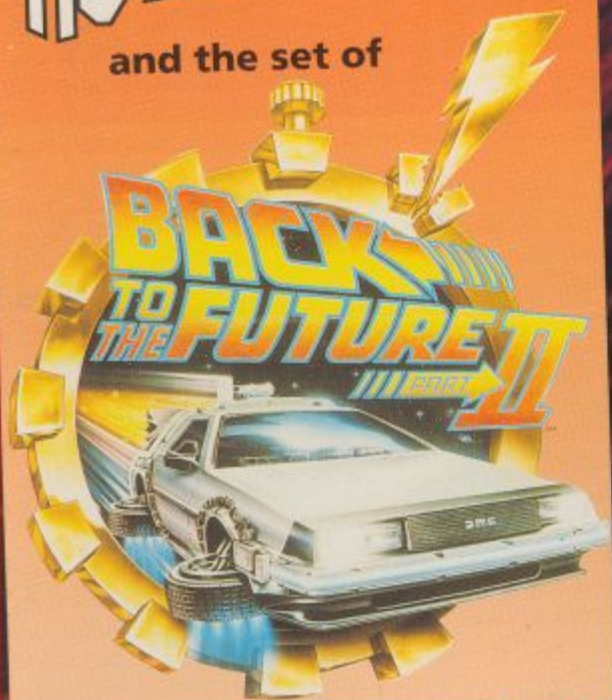

### STAR WARS

Origin's  
cinematic space-sim



### HANDHELD ENGINE

Hands-on testdrive of the portable PC Engine



Over  
**40**  
games  
reviewed and  
previewed



# INTO THE M.C.I.

There's nowhere to hide from... "SLY SPY"  
His calling card is your invitation to dance with danger!  
Experience the explosive existence of the secret agent in this arcade action thriller that will leave you gasping for breath!

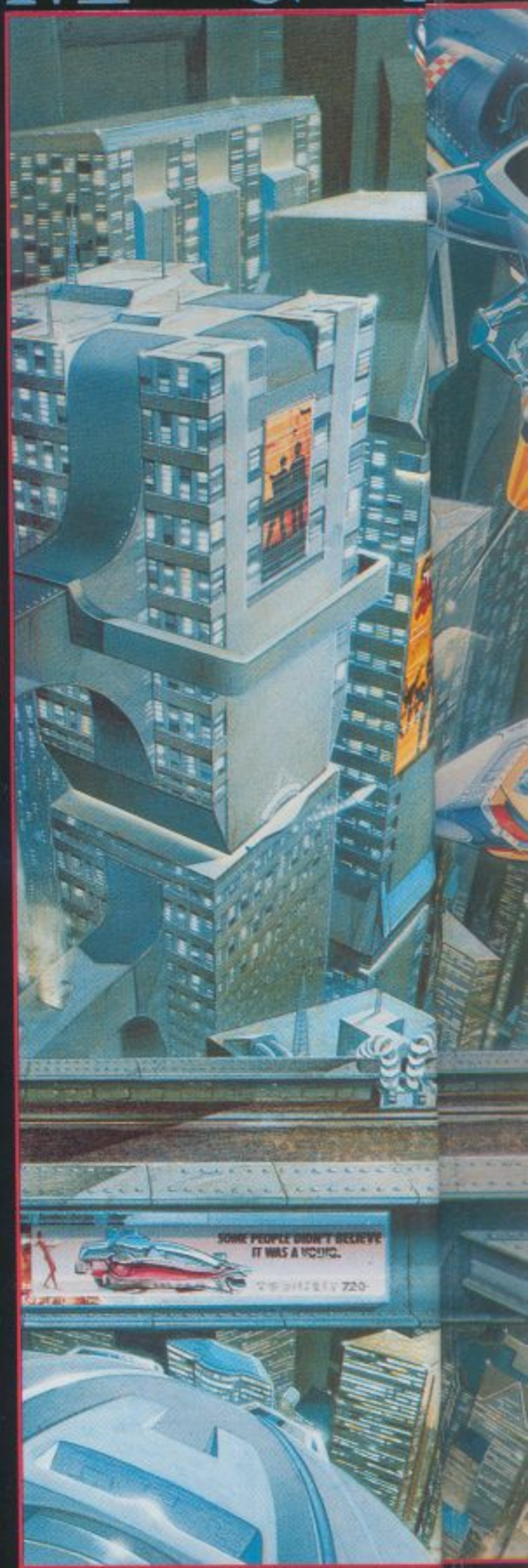

DATA EAST



**THE FASTEST, MOST THRILLING, 3D DRIVING GAME YET!**

Take the wheel of your turbo-charged Porsche as you and your partner go in pursuit of dangerous criminals all driving an evil array of souped-up roadsters. Need to catch up in a hurry? Well, just one press of your **Turbo Button** will leave your eyes in the back of your head!



From the Island of Doh to Monster Island you will encounter Doh himself, stinging insects, hideous toy creatures, lethal combat machines, mechanical assailants, the formidable beings of legend and folklore and finally you will enter the world of darkness and its inhabitants! Featuring all 7 islands and faithfully reproducing the fun and excitement of this monster arcade hit.

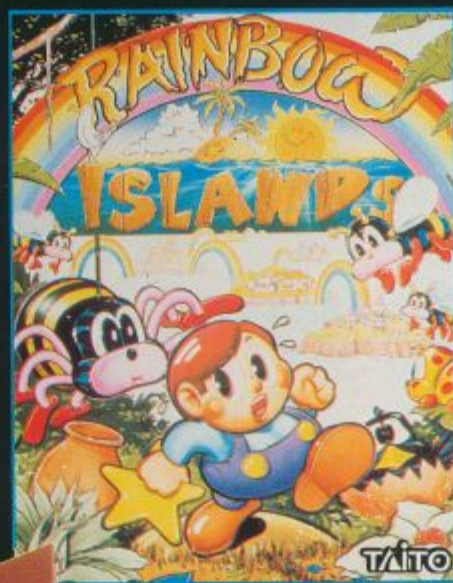

\*ALL GAMES AVAILABLE ON SPECTRUM, AMSTRAD, COMMODORE, ATARI ST, CBM AMIGA.

\*F-29 RETALIATOR ONLY AVAILABLE ON ATARI ST & AMIGA.

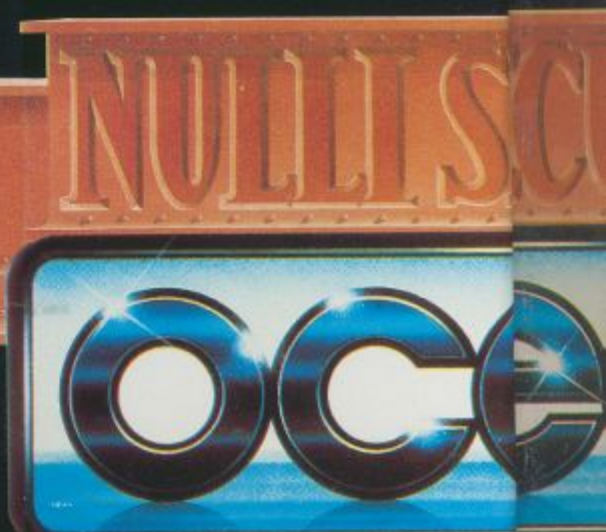

# MAX FUTURE



Utterly mouth-watering graphics and an amazing depth of play ... the best flight simulation I have ever seen (and there's nothing on the visible horizon that looks set to come close). It's not a simulation, it's an experience ... Ocean's first flight sim is the best out!" Zzap 97%.



## SHADOW Warriors

**SHADOW WARRIORS**, the latest, greatest and most ambitious martial arts coin-op game now rages onto your computer featuring interactive scenic backdrops! The secrets of the Ninjitsu assassination techniques have been handed down since the Mediaeval wars...now they live on in the jungle of the American metropolis. A thousand years of the Ninjitsu secrets at your fingertips... the Phoenix Backflip, Triple Blow Combination, Flying Neck Throw, Hang Kick and more, give you a formidable amoury of stunning moves. Take your techniques to the streets **SHADOW WARRIOR...** the hero of the nineties.





**EMAP IMAGES**  
**PRIORY COURT**  
**FARRINGTON LANE**  
**LONDON EC1R 3AU**  
**TEL: 071-251 6222**  
**FAX: 071-490 0991**

**EDITOR**  
 Steve Cooke

**DEPUTY EDITOR**  
 Rik Haynes

**REVIEWS EDITOR**  
 Laurence Scotford

**DESIGN EDITOR**  
 Jim Willis

**CONTRIBUTORS**  
 Eugene Lacey  
 John Cook

Christina Erskine  
 Pat Winstanley  
 Mark Patterson  
 Tony Dillon  
 Ben Mitchell

**ADDITIONAL DESIGN BY**  
 Pete Hawkes

**ILLUSTRATION**  
 Geoff Fowler

**PHOTOGRAPHY**  
 Edward Park

**ADVERTISING MANAGER**  
 Jo Cooke

**DEPUTY ADVERTISING MANAGER**  
 Jerry Hall

**ADVERTISING PRODUCTION**  
 Melanie Costin

**PUBLISHER**  
 Garry Williams

**SUBSCRIPTIONS**

EMAP Frontline, Subscriptions Department  
 1 Lincoln Court, Lincoln Road,  
 Peterborough, PE1 2RP  
 0733 555161

**COLOUR ORIGATION**

Balmoral Graphics, Canonbury Yd, N1  
 Proprint Repro, Barking Road, E13  
 Faxime, Fanshaw St, N1

**TYPESETTING**

CXT, 1 Tanner Street, SE1

**DISTRIBUTION**

EMAP Frontline, Park House, 117 Park Road,  
 Peterborough, PE1 2TR

**PRINTING**

Severn Valley Press, Caerphilly

© EMAP IMAGES 1990

No part of this publication may be reproduced in any form without our permission.

## GAMEPLAY

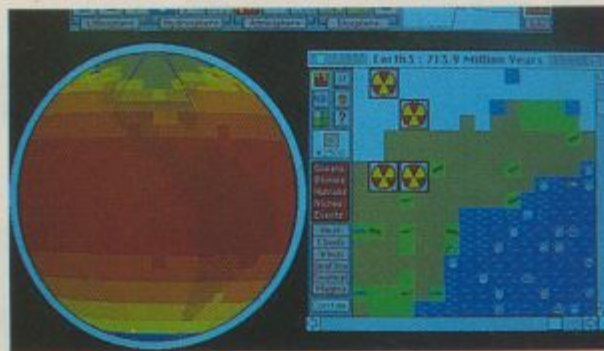

### SIM EARTH .....32

An exclusive look at the sequel to the stunning *Sim City*.

### SCREEN TEST .....37

Red hot reviews...*Wing Leader*, a soaring 3D space fantasy from the producers of *Ultima VI*; Millennium's *Thunderstrike* combines arcade playability and flight sim detail; *UMSII* allows you to battle it out across a whole planet...and many more.

### CONSOLE GLORY .....58

Our new console software section includes *Powerdrift* on the PC Engine, *Batman the Movie* on NES/Gameboy, *Tetris* on the Megadrive, and *Ultima IV* on the Sega Master System. Enjoy...

### CD SENSATIONS .....62

Check out these superlative CD titles under production by Sierra On-Line.

### ACE UPDATES .....62

The latest conversions, including *Klax* and *Pirates* on Amiga and *Sim City* on ST.

### TRICKS AND TACTICS .....89

The first part of a complete solution to *Drakkhen*, maps of *Xenomorph*, and a mega-hack for *Bombuzal*.

### NEO GEO CHALLENGE .....79

Will the Neo Geo coin it on the streets? Plus more arcade news including *Moonwalker*, and *Smash TV*

### ACE NEW WORLDS .....83

*Manhunter II*, *Secret of the Silver Blades*, plus hints and tips in Pat Winstanley's fantasy column.

## THE ACE TREATMENT

The latest releases on computer and console, each given the authoritative ACE treatment...

### ON COMPUTER .Pages 37-56

AMOS Mandarin .....	56
APOCALYPSE 4th Dimension.....	54
BAD BLOOD Origin.....	40
BSS JANE SEYMOUR Gremlin .....	52
CHESS CHAMPION 2175	
Oxford Softworks.....	52
DELIVERANCE STORMLORD II	
Hewson .....	51
FALCON MISSION DISK TWO	
Mirrorsoft .....	46
F19 STEALTH FIGHTER	
(ST Version) Microprose .....	47
FLIGHT OF THE INTRUDER	
Mirrorsoft.....	46
FLOOD Electronic Arts .....	42
PERISCOPE SIMULATOR Marconi ..	48
POWER BOAT Accolade.....	51
PROJECTILE Electronic Arts .....	54
PROPHECY ONE Electronic Zoo .....	42
RAIL ROAD TYCOON Microprose .....	50
THUNDER STRIKE Millenium .....	44
TURRICAN Rainbow Arts .....	42
WING LEADER Origin .....	38
UMSII Rainbird.....	53

### ON CONSOLE ....Pages 58-61

BARUMBA .....	PC Engine
BATMAN THE MOVIE .Gameboy/NES	
POWERDRIFT.....	PC Engine
SNOOPY .....	Gameboy
TETRIS .....	Megadrive
THUNDERFORCE III.....	Megadrive
ULTIMA IV.....	Sega Master System

## HOLLYWOOD HERE WE GO!

ACE takes you to Hollywood in more ways than one in this issue. First there's our mega competition that could fly you to Celluloid City, the set of *Back to the Future*, and the trip of a lifetime – see page 26. Then on page 16 there's an exclusive location report from Pixar in North California – a group of graphics special-effects wizards who used to be part of the Lucasfilm empire. You can find out more about the parallels between game and film production in *That's Entertainment* on page 74, and there's a special investigation of film licensing on page 23. It's all part of the ACE Special Issue plan – bringing you the latest game reviews – and a good deal more.

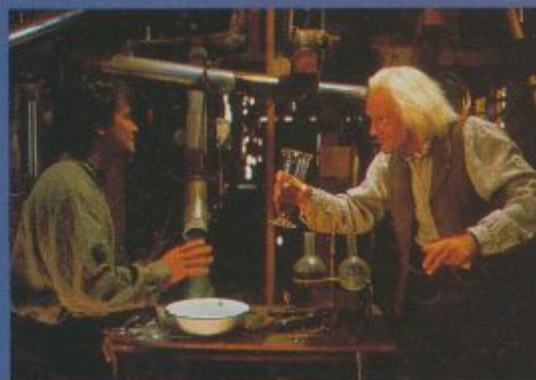

Univesal's *Back To The Future II* - just one of the recent movie blockbusters that's set to make the transition from celluloid to silicon. Find out about other movie license deals on pages 23 and 24, and meet a Hollywood license hunter in the process.

# FLY TO

# GOING FOR GOLD

Things are changing here at ACE as we introduce a series of improvements to the magazine that's already acknowledged as the UK's finest for the sophisticated gamer. First, the **SPECIAL ISSUES** plan. You'll have noticed in recent months that several issues of ACE have carried a theme. So far we've had a **Hyper Issue** (looking at Hypermedia), a **Euro Issue**, a **3D Issue**, an **American Issue**, and - this month - a **Hollywood issue**. We've had great feedback from readers on this, so from now on we'll be continuing the tradition with special issues on - amongst others - Japan and Russia. ACE has always been renowned for giving you more than great games coverage and the ACE Special Issue plan will ensure that you'll get more out of the magazine than ever. Then there are our **DEDICATED REVIEW SECTIONS** for computer, console, and CD. We've introduced these because the world of games is changing. ACE readers have always been one step ahead - now we've given you regular sections that between them will cover **ALL** the major games releases for the foreseeable future. Again, no other magazine gives you such comprehensive coverage. We're also busy **REDESIGNING** the magazine to ensure it looks as contemporary as the topics it covers. This process will be completed by the October issue and will result in a more vibrant, varied style to maintain the magazine's reputation as a pacesetter in terms of style as well as content. Finally, we're planning a **MAJOR NEW SECTION** for launch at the CES Show in September. But **THAT** will have to remain a secret!

## SPECIALS

### TOTAL REALITY ..... 16

Academy Award winning animators Pixar have produced a package for micros that could revolutionise graphics programming.

### THAT'S HANDY! ..... 73

Hand-held war hots up as NEC launch their scaled down version of the notorious PC Engine.

### PREPARE FOR INVASION ..... 20

Robocop for the Gameboy, a PC that's Nintendo compatible, Days of Thunder from Mindscape - all showing at the world's largest consumer electronics show in Chicago. ACE was there...

### HOLLYWOOD CAPERS ..... 23

Meet a man who wheels and deals in the big, bad world of movies - hunting down film licenses for British gamers.

### THAT'S ENTERTAINMENT ..... 74

From making games to making movies - John Cook explores the links between silicon and celluloid.

### OLD BUT GOLD ..... 71

Every so often a game comes out that stretches the boundaries of computer entertainment. First in a new series about games that made history.

### CD-I GETS SETS ..... 10

CD-I gets full-motion video capability and may appear sooner than we think. A report from the London CD-I Multimedia Conference.



The software technology that produced this frame and the central wave image on this spread could soon be running on your micro. See page 16.

## REGULARS

### ACE NEWS ..... 7

SAM goes bust, Activision's *Aliens Vs Predator*, and a host of other whispers from the world of advanced computer entertainment.

### YOU SAID IT! ..... 13

Feedback on the CD-TV, licensing, and a host of other subjects that ACE readers feel demand your urgent attention.

### THE ACE CLUB ..... 96

ACE gives you the latest, greatest games - and much more. Save money on a subscription.

### COMING SOON ..... 29

What's on the cards for the next issue of Britain's best games technology magazine?

### IN THE PINK ..... 99

The ACE Charts and Stockmarket, giving you the best indication of which games to buy. Plus the ACE Crossword and Puzzle.

### PAGE 11 ..... 11

Games to watch out for, presented in typical, inimitable Page 11 style.

## WIN! WIN! WIN!

### FLY TO HOLLYWOOD ..... 26

What a prize! Not only do you get the chance to fly to Universal Studios in Hollywood, but we've even added a special bonus feature that could give you £500 in cash to spend while you're there! Get the full, silver screen story here and enter NOW.

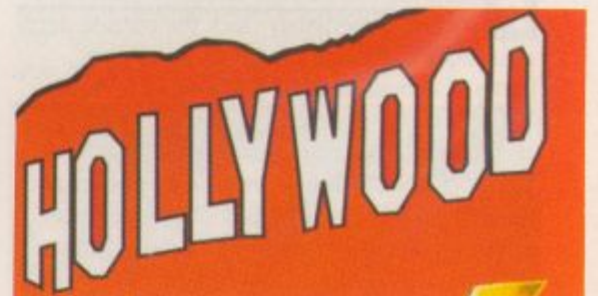

# HOLLYWOOD

# NEWS

## ATARI AND ACORN PREPARE CD MACHINES

**A**n Atari ST with built-in CD drive is to be launched next year. And Acorn is considering launching an all-in-one version of the BBC A3000 with Compact Disc drive.

The Atari CD-ST will be in direct competition with Commodore's CDTV (exclusively revealed in ACE 34) which software developers around the world have received over the past month. As yet no price has been fixed but it is thought likely that buyers will be required to fork out something in the region of £600.

Atari president Sam Tramiel has stated that he wants to make the advanced CD-ST as accessible as possible. Software publishers are already working on a variety of titles - many of them games. Two have already been completed.

Meantime, Next Technology in Cambridge (which helped in the development of the Amiga CDTV) says there is a real possibility of a similar machine from Acorn. Next was responsible for

the Archimedes CD drive which is currently being sold as a separate peripheral. The firm has also worked with IBM on similar projects.

ACE readers need not be reminded of the Archimedes' astonishing capabilities in graphics and speed and such a machine would clearly appeal to gamers searching for truly state of the art kit.

Next president Graham Brown-Martin explained: "The Archimedes would be a very suitable platform for such a project because of its speed and graphics capabilities. We have talked about it and there have been a lot of good ideas. But I can't say anything more apart from that it's open to speculation."

Acorn, in characteristic form, denied any such project. Spokesman Michael Page said: "It bears no relation to anything I've heard." Nevertheless, the Acorn rumour mill is in full motion.

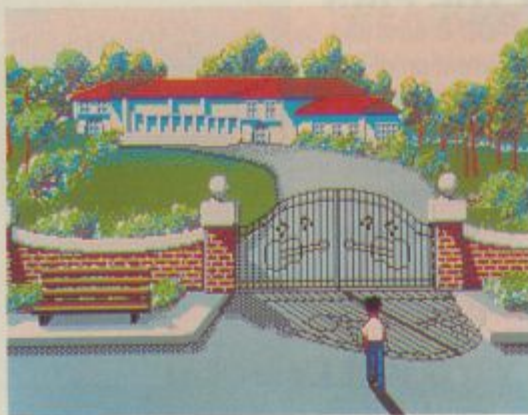

A very graceful location in Accolade's Search for King!

## KING FOR A DAY

**R**ecognise this humble abode? Astute readers will immediately clock the outside decor as being just a shade similar to Gracelands, home of former Rock 'n' Roll king Elvis Presley.

Curious then that it's just one of the locations in Accolade's up and coming game *Search For the King*. The adventure, written by Hacker and Hacker II author Steve Cartwright, has players searching all over the place for a missing superstar called The King.

In the graphic intrigue you have to travel around the US putting to use a variety of bits and bobs in an attempt to find this gauche star. The late Mr Presley isn't named in the game. But publisher Accolade clearly doesn't believe many gamers will have any illusions as to who the much loved "King" is based on.

## MICKEY MOUSE SOFTWARE

**S**oon you'll be able to recreate the classical characters of animation master Walt Disney on your home computer.

Disney's software label is to launch *The Animation Studio* for Amiga, ST and PC later this year. The program utilises cel animation techniques first perfected by Disney. Artists and novices alike will be able to create and animate full length sequences.

You can also perfect the see-through technique known as 'onion-skin' technology which allows you to time the movements of each part of a character's body. You can also superimpose images on any background with music and sound effects to boot.

*The Animation Studio* will be launched here through Titus for about £100 and consists of three disks with sample Disney animations which can be modified as well as a full length demo disk. Buyers will also be offered the chance to win a trip to, you guessed it, Disney World.

Other Disney Software offerings on the way include a game based on Madonna and Warren Beatty movie *Dick Tracey*, and *Arachnophobia* - the movie conversion of Steven Spielberg's latest.

## MULTISYSTEM AND COUPE: WHATEVER NEXT?

**W**hat the devil has happened to those two hardware "wonders" of 1989, the Konix Multisystem and MGT's Sam Coupe?

Unfortunately there's little in the way of good news. Konix hasn't said a word about its curious creation since the end of last year and MGT, well, the firm is in a spot of bother.

Software developers working on the Konix have all but stopped making any effort to produce games. System 3 managed to finish a version of *Last Ninja II* but the company doesn't know what to do with the game.

Most other software houses have simply put their projects on ice until further word is received from Welsh firm Konix. That company has been attempting to get back into the groove following a management buy-out late last year. Attempts to talk to any senior figures in the company are drawing a blank.

This is all very unfortunate for gamers. The Multisystem is, in theory, one of the most innovative pieces of hardware to be produced in recent years. Its variety of control devices which included motorcycle handlebars, a steering wheel, flight yoke and chair a la *Thunderblade* wowed everyone when the machine was launched in 1988.

However, some industry pundits are beginning to wonder if time isn't running out for Konix. Since the original Multisystem launch, up to a dozen consoles have been launched around the world.

Meanwhile, Miles Gordon Technology has slipped into receivership and, at the time of going to press, was looking for a buyer to take over the Spectrum compatible Coupe.

"It's the company that's failed - not the product," lamented Alan Miles, one of the founders of MGT. "We owe it to our customers, the developers and ourselves to try to find a stronger company to take on the Coupe and the later products we had planned."

Apparently, Coupe owners are being pointed in the direction of the Sam User Group...

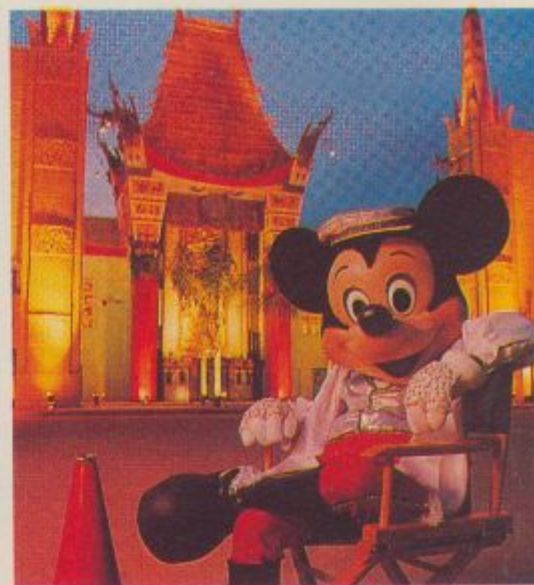

# NINTENDO GETS TOUGH WITH CHEAT MACHINE

**P**okes and cheats are generally accepted to be an everyday part of computer gaming – until now.

Nintendo of America has cracked down on a company which has been selling a device designed to make certain games easier to play. The gadget, called the Game Genie, allows players to skip levels across a broad spectrum of Nintendo games.

For instance, in *Super Mario Brothers* the Genie will allow you to jump past levels which have been mastered and will allow you to slow down difficult levels.

Although the Genie was being sold by a company called Lewis Balooob Toys in the US it has been designed by an altogether more familiar company – Code Masters of the UK.

A spokesperson for the Coders "could not confirm nor deny whether the product is ours" but admitted that it was all "a tricky legal situation".

Brian Moore of Nintendo's UK distributor Serif explained why the firm is so annoyed with a gadget which purports to help hapless punters. "The designers of games spend a long time getting everything right. This is a copyright of infringement," he said.

Code Masters had released its Genie into the US before a UK launch because of the Nintendo's huge popularity over there. It is thought likely that similar projects have been underway for other consoles or even computers.

## ALIENS vs PREDATOR: THE GAME

**T**wo of cinema's nastiest horrors are to appear in the same computer game courtesy of Activision. *Aliens vs Predator* pits the extra-terrestrial human hunters against each other in a battle bound to be of gargantuan proportions.

Activision's chairman Bruce Davis has no doubts about the attractive nature of his grizzly characters. "It's the ultimate match-up of the 1990's," he enthuses. "Ask any kid to name the biggest, most frightening creatures of our time and they'll tell you these are it. Not since *Godzilla versus King Kong* have such widely known creatures come together in a science fiction conflict of this magnitude."

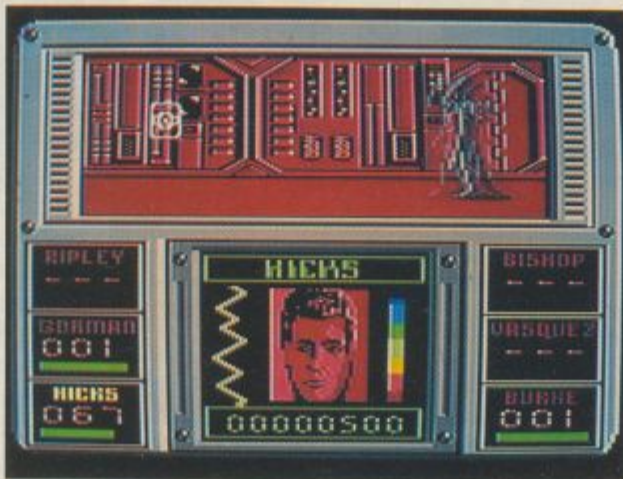

The original *Aliens* from *Electric Dreams* (Activision)



Moviegoers and video gamers alike will recall that the Alien is a thoroughly appalling creature which does unpleasant things to space travellers while Predator takes a gruesome pleasure in carving up all humans – using their skulls as trophies.

The characters are taken from Twentieth Century Fox's forthcoming films *Aliens III* and *Predator II*. Activision was also responsible for the computer versions of *Aliens* and *Predator* movies.

The original *Predator* was designed by System Three for Activision

## ONLY A GAME...

**T**he bizarre theory that computer games can rearrange your brain cells may have some credibility after all.

It seems that a key member of the USA's hapless soccer team - namely the goalkeeper Tony Meola - sharpens up his dubious reflexes with the aid of Nintendo video games.

Stranger still is the story of the convicted US murderer whose last request was to play his favourite computer games before being aided on his way to the next world.

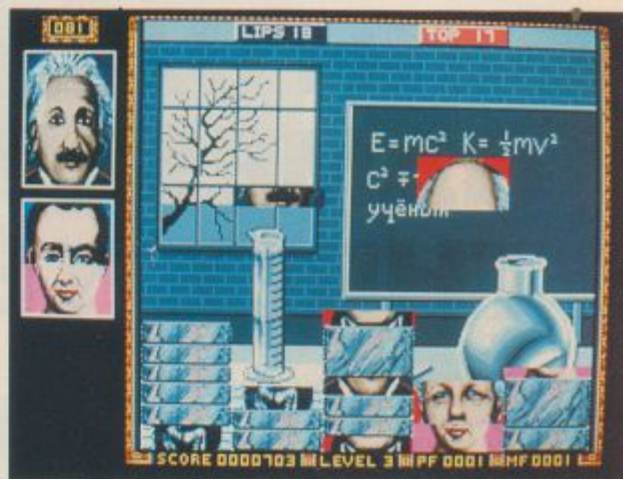
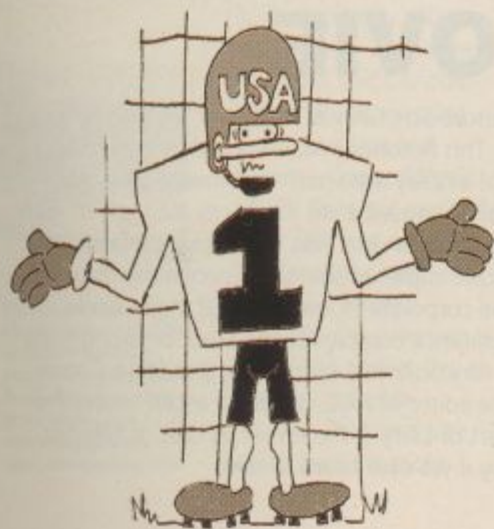

Imagine Tetris, add colour, sophisticated sounds and a very human element and you've got Faces

## FACES FACES CHALLENGE

**I**magine Winston Churchill's jowls, Napoleon Bonaparte's nose and the eyes of Marilyn Monroe - all on one face. That could be the intriguing result of a new game – the follow up to the enormously successful Soviet game *Tetris*. *Faces* works on much the same principle as block building wonder *Tetris* but instead of weird bricks the player has to arrange horizontal slices from faces – famous or otherwise.

It's the third game from designer Alexey Pajitnov whose *Tetris* is widely regarded as one of the best computer games ever. Pajitnov, 35, works at the Computer Centre of the USSR Academy of Arts in Moscow and spends his legitimate working time developing advanced voice recognition systems. He only began writing computer games to learn more about the hardware and, in the past five years, has put together fifteen brain crunching teasers. He attracts much praise for writing games based on construction rather than the opposite.

*Faces* is sure to be one of the most challenging games of the year. Segments of the faces fall in pairs and often have to be swapped over. If you make a mistake in building a face the visage will turn to marble. However, points are awarded for complete faces even if chins, eyes and cheeks do not completely match. Completion of a bona fide face means more points.

As yet no UK publisher has been arranged but the game is being released in the US by Spectrum Holobyte which has close connections with Mirrorsoft here. That firm was also responsible for *Tetris* in the UK

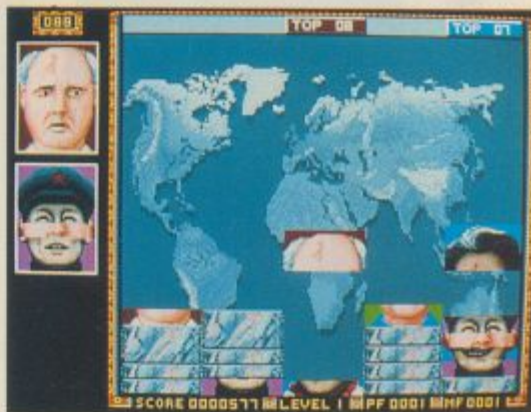

# VIRTUAL REALITY GAMES WITHIN THREE YEARS

**A**CE can exclusively reveal that Nolan Bushnell, the father of the video game, is developing a virtual reality product for the leisure consumer market. He expects a finished, marketable, consumer product within the next three years.

Virtual reality (VR) is possibly the most exciting concept for video games since they began. Amazingly, VR was originally developed by NASA. The VR idea is to create a complete artificial world inside your computer or console! You interact with this world - also known as cyberspace - using sophisticated human-machine interface peripherals such as data glasses, gloves and even suits. You're able to view and visit this artificial world as if it was real. You enter a virtual reality.

*The Mattel Power Glove: the first steps towards a total VR game experience*

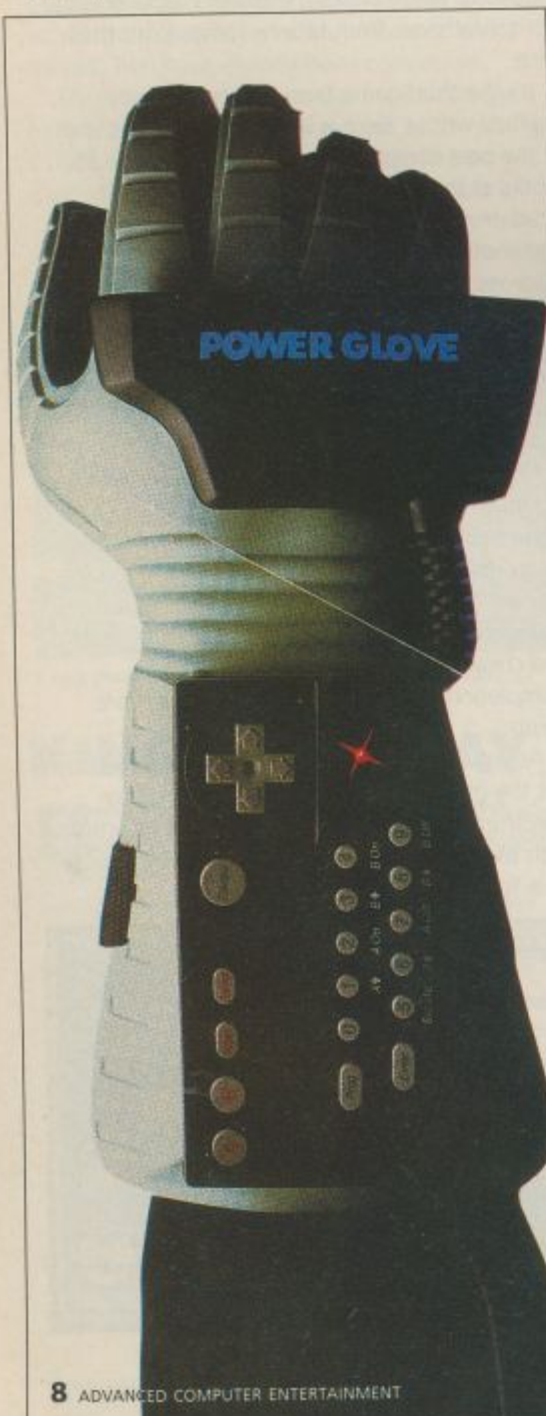

There is already a VR 'joystick' available on the Nintendo NES console. The Mattel Power Glove, developed by a cyberpunk Californian company called VPL, fits over your hand and allows you to actually punch while playing a boxing simulation or karate chop your opponent in a kung fu game.

Bushnell was the co-founder of Atari in the 70's and is currently helping Commodore launch its CDTV. "There are a series of things that are happening that will accelerate the development of consumer cyberspace," Bushnell told us.

But as for any more details, all he would say was: "I believe virtual reality is an important thing. Stay tuned to this channel". And stay tuned to ACE for the first news of tomorrow's games technology.

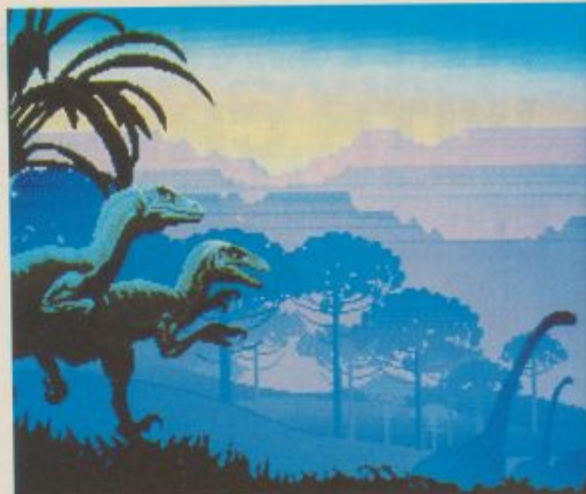

*Origin modelled the movements of the dinosaurs in Savage Empire after the latest in paleophysiological evidence!*

## BRAVE NEW WORLDS FOR ULTIMA FANS

**U**ltima, the award-winning ACE-rated series of fantasy role-playing games, has just given birth to a healthy bouncing baby. Origin is celebrating *Ultima's* 10th anniversary with the launch of *Worlds of Ultima: The Savage Empire*. The best just got better.

*Savage Empire* is the first in the *Worlds of Ultima* series, and uses an enhanced version of the 'dynamic world simulation' system found in the superlative *Ultima VI: The False Prophet*. But instead of placing you in the familiar fantasy kingdom of Ultima, *Savage Empire* throws you into an exciting new world populated by dinosaurs, stone-age tribes, mad scientists, aliens, steamy jungles and lost cities.

The game is typical of the complexity and excellence found in Origin titles. It mixes pulp fiction of the 30's with accurate animation of dinosaurs - to create a thrilling fantasy role playing game.

*Savage Empire* is due for release in the autumn on PC for \$59.95dk. Amiga and ST versions will follow later in the year. Origin told us other *Worlds of Ultima* games are already in the pipeline.

*Origin's Savage Empire: "two-fisted adventure, spine-tingling graphics, pulse-pounding sound, cliffhanging excitement"*

**Dial  
0898 555563  
NOW!**

The ACE Interactive News Line is the only way to get a weekly update on the latest games gossip, games technology and games in progress. Plus you get the chance to win special prizes - every week. Just dial 0898 555563. Calls cost 38p per minute peak, 25p per minute off-peak. The service is updated every Tuesday at midday.



## LEISURE SUIT LARRY: THE MOVIE

**T**he sleazy star of the popular *Leisure Suit Larry* 'interactive sex-ventures' is set to make a move to the silver screen.

Warner Bros. is one of the major movie companies interested in turning this infamous Sierra On-Line games character into a film hero. Could Leisure Larry become the Dirty Harry of the 90's?

For those not in the know, the *Leisure Suit Larry* series of games concentrate on one simple theme. Sex - and how Larry the lounge lizard can get more of it. The latest chapter,

*Leisure Suit Larry III*, has Larry 'looking for love'.

This notorious American adventure game has already attracted mainstream press coverage. It caused a stir in the city a couple of years ago after a virus was found to be attached to pirate copies of the game circulating through the corporate PC networks of major banks, insurance companies and stock brooking firms.

Unconfirmed reports suggest Steve Cooke, the editor of ACE, has been asked to play the part of Larry in the movie. A case of typecasting if we ever heard of one!



CD-I in different shapes, sizes, and colours. These machines come from Panasonic, Pioneer, Ricoh, and others. Philips hope to get the CD-I cost down to just \$100 above the cost of a normal CD audio machine, leading most CD audio manufacturers to include a CD-I option in their standard audio ranges



Sony's portable CD-I in prototype form. The colour LCD display is extremely bright and attractive - it'll look even better with Predator 2 running on it!

### TV WINDOWS

A US company has produced an extraordinary add-on for the Mac that could catch on with Amiga and ST owners if a conversion is produced.

The MicroTV allows the user to watch telly on your monitor while running another application. The system puts up a small window (which you can move just as you would any other WIMP window) with the TV program running inside it. Although currently monochrome only, a colour version is expected next year.

For more details, contact Aapps Corp, 110 Pioneer Way, Mountain View, CA94041, USA.



# CD-I FIGHTS BACK

**Philips and Sony are fighting back following the lead taken by Commodore's CD-TV in the race to produce a CD-based video home entertainment system.**

The CD-I team launched a multi-media conference at London's Royal Lancaster Hotel with exhibitors from Japan and Europe and host of new hardware.

Most startling of all were the prototypes for a Sony portable CD-I machine. Combined with the announcement that CD-I, when it launches next year, will come complete with full motion video capability (FMV), this means that you could be watching your favourite movies while sitting on the bus by next Christmas.

With FMV, CD-I now promises to offer full CD audio capability, CD video (up to 72 minutes per disk), and CD computer data processing (for interaction and games). Commodore's CD-TV does not currently offer FMV and although the company have promised an FMV upgrade, the pressure is now on to deliver this as soon as possible.

This pressure could become more

intense if hints dropped by Philips at the conference that CD-I could be launched earlier than previously thought. Although originally scheduled for release back in the mists of time, the most recent date put forward by Philips for a UK launch was Christmas 1991. However, a Philips spokesman at the show indicated that this may now change and we could see systems available in the Autumn or even earlier. Certainly the systems demonstrated at the conference seemed to be at a very late stage of development, though some bugs were still painfully obvious in the demonstration software.

### WE HAVE THE TECHNOLOGY

The age-old science fiction dream of the Six Million Dollar Bionic Man could come true sooner than you think.

A team of physicians and electrical engineers from Stanford University in the States have designed a chip that features thousands of microscopic apertures. When a limb is amputated, the existing nerve ends are severed and destroyed. Using the new chip, the old nerves regrow and pass their fibres through the holes in the chip. Each fibre is then interfaced to the controlling computer.

The computer scans the electrical impulses sent by the nerves, each of which signals a particular muscular movement. This information can then be used to manipulate an artificial limb.

The challenge, however, is first to interpret the meaning of the nerve signals. This can only be done through extensive trial and error, nerve scanning, and heavy duty programming. Since there are millions of different combinations, the work is far from over! However, the chip has already been tested successfully on rats.



Yet another CD-I application - this juke box holds hundreds of songs. FMV could bring us video jukeboxes too...

There's no doubt that the entertainment medium of the future is the one that combines FMV, audio, and computer data. Whoever gets there first is going to reap rich rewards. At present there's an admirable gallantry about the Philips/Commodore conflict: 'We've seen the CD-TV and we think it's a very nice piece of kit,' said one Philips spokesman, 'but they're taking a tremendous risk. It doesn't have FMV and it isn't CD-I compatible - and CD-I is the standard that most manufacturers of similar equipment will be following.' Commodore, on the other hand, maintain that the Amiga power of the CD-TV means it can do anything CD-I can, except better.

Wouldn't it be nice if we got just one standard instead of two? Perhaps Commodore could include a CD-I chip set as an upgrade for the CD-TV? We live in hope...



No, it's not a ghetto blaster - it's a CD-I ghetto blaster! Another product prototype from Sony - Christmas 1991 is certainly going to be make-up-your-mind time. Start saving now!

THE FINAL

# BATTLE

TM

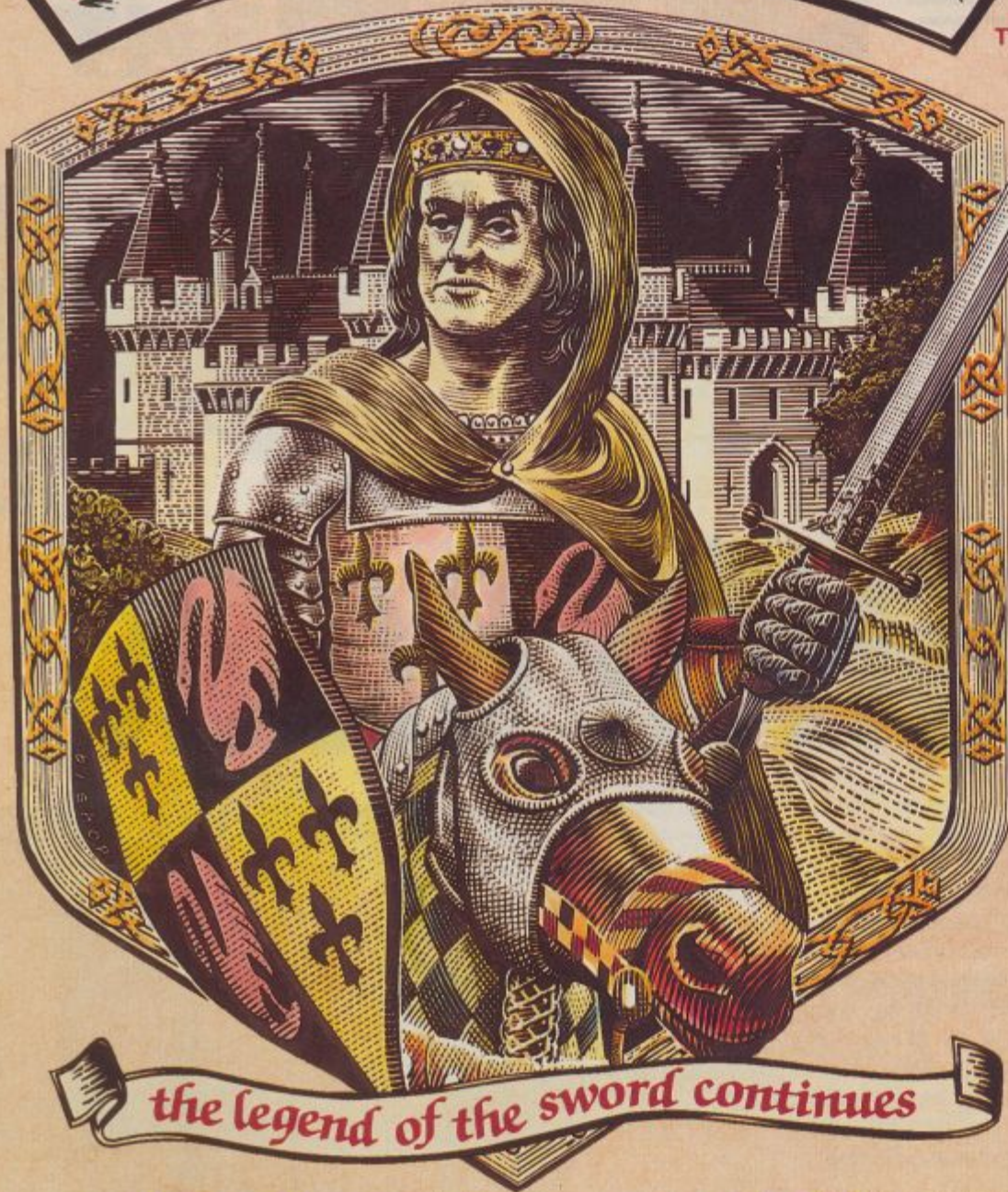

IN THE BEGINNING  
THERE WAS A SWORD,  
THEN CAME THE  
ADVENTURE.



A wizard trapped in a teardrop. A magical sword. A race of mutant humanoids.

Their attempts to destroy the kingdom were thwarted by a band of fearless adventurers. In the chronicles of Anar that chapter became known as the Legend of the Sword.

Then the teardrop shattered and the wizard unleashed a plague of death and destruction upon the land. The world of Anar has one remaining hope: whoever recovers the six power crystals created when the sword was forged, may banish the wizard to the deepest pit of hell...



Final Battle, the sequel to the much-acclaimed Legend of the Sword, features a much larger vocabulary, an expanded inventory and superior graphics. Its highly sophisticated action system allows for weather changes and gives a 3D view of every location – a system at the forefront of contemporary adventuring.

When the teardrop explodes, only the brave can save the land.

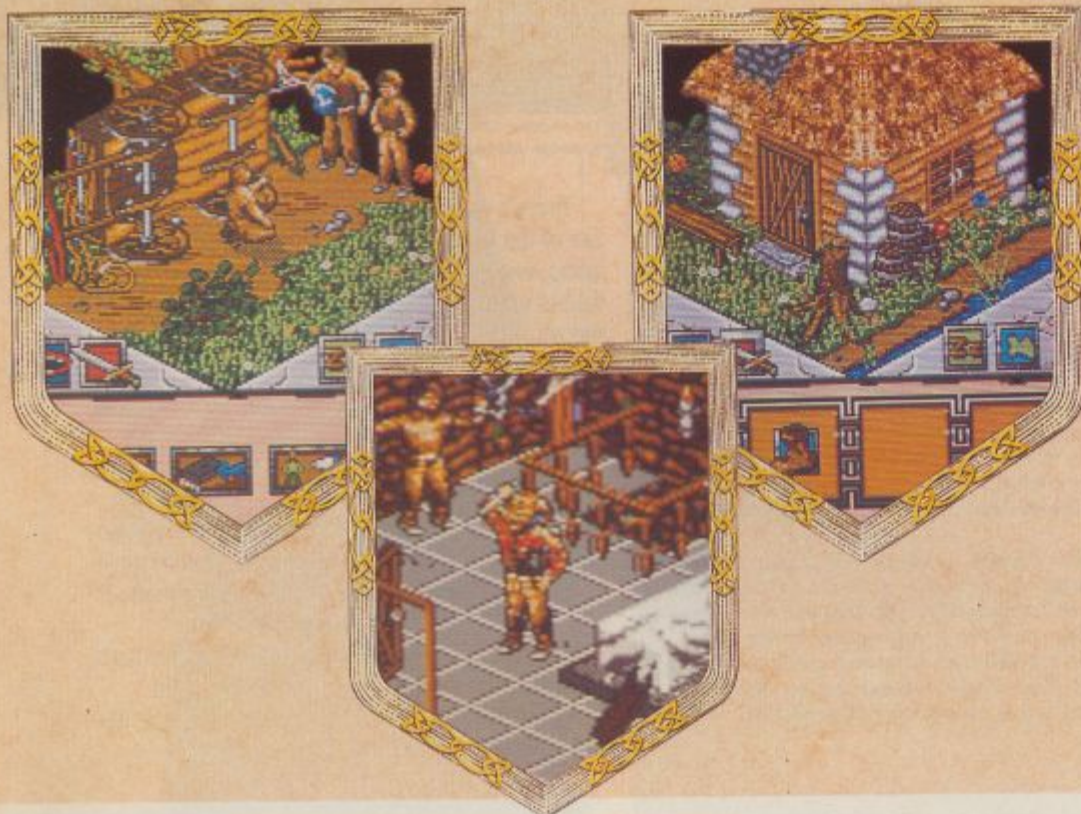

NG  
ORD,  
E

# GO GET 'EM

Stuff that should be ripe for the picking any day now...

Remember *Bugaboo*? Now defunct software team Quicksilva had a good productivity session and the result was a bouncing baby flea that caught the hearts of games players world wide (aaahhh...). Now insects are back with a vengeance in *Venus—the Flytrap* from Gremlin.

Dateline: the future

The planet is damaged beyond repair... ecological stress has taken it's toll. Nature is out of balance. There's only one way to save the day – create new species! But... DNA disaster strikes. A mutant virus is on the loose, and results in a breed of rogue killer insects.



**Don't just Live and Let Die – Fire and Forget. The wolfmen at Titus are working away on red-hot conversions of *Fire and Forget II – The Death Convoy*. Yep, there's a convoy in town, and there ain't no sissy Rubber Ducks in this crowd. These are Nuclear Packing Terrorists on their way to cause some Dastardly Destruction. Only you can save humankind, and only the ultimate combat vehicle can help you. Owners of all major machines can work their way along the convoy aiming to destroy the leading vehicle before facing the ULTIMATE EXPLOSION...**

Gallic games get greater. Well those from Infogrames do.

*Metal Masters* is a mighty mash between mammoth malign robots. Can you construct a robot strong enough to fight its way to the

top in one of ten combat arenas?

We rush forward in time once more to the year 7014. The Human-Cyborg war has raged for 263 years and their ain't many humans left. Only one man can save humanity – Captain Steve Jordan – and only the ultimate combat vehicle can help him (Right! Hold it right there... Stop the preview page! We've had all this once before on this page. Let's have some original copy shall we! Good... er... OK. Carry on...). The Eagle, a chase-interceptor constructed by the enemy is the only craft that can get Jordan, as the *Eagle Rider* through to the Cyborg Mother Planet. Feel like saving the universe? Then this arcade adventure is for you!



Can anything wipe this plague from the sky? Yes! The Fly! Not Jeff Goldblum but the ultimate in pest control. You too can shoo in style for a while with reverse gravity icons, big shots, 3-Way shots, and power-ups galore in *Venus*, buzzing the way of all Amigas and ST's soon.

**Where have Hewson been of late? Tucked away working on some superb new versions of some very old games. Braybrook is back with *Paradroid '90*, an all new version of everyone's favourite droid bashing game. Go battle those droids for spare parts for your own R2D2 rip-off.**

**More hard work has gone into finding an original name for the sequel to smash hit *Nebulus*. And here it is (tara tara tara): *Nebulus 2*... Good eh? Arcade puzzle fans who managed to climb every tower in the first game can now exercise their grey matter and their pinkies in guiding the little green**



**fella through even more screens full of stunning graphics. Check the shelves soon.**

# BETRAYAL

*Your Father's been murdered,  
Your Peasants are in revolt  
and your wife's run off with your best  
friend - the Kings' brother.*

*Quite possibly the best news you've had  
for some time!*

*Betrayal.*

*From Rainbird.*

*A web of intricate possibilities - but fair  
play isn't one of them.*



MASTERS OF STRATEGY

# Feedback

## More response to CD-I, and a thought on the increased responsibility that goes with advanced technology

### LICENSED TO THRILL?

I am writing to you after seeing the results of the phone-in debate about software licensing. If 75% of your readers think that licensing should stop, how come games like Robocop stay in the charts for near-

ly a year, and at the moment there are 12 licensed games in the charts?

I buy quite a few licensed games for my Amstrad. I don't buy them on the strength of their name alone, but because I read the reviews, and if the game is good then I will eventually buy it. So I think licensing should continue.

**David Pearce, Southampton**

• Yes, it is odd that such apparently strong feeling against licensing does not seem to affect the sales of licensed games. Licensed products are easier to sell than original

games, because a lot of the publicity groundwork has already been done. With a major hit movie like Batman for instance, computer games are only one example of the type of associated merchandise that can be sold on the hype behind the film. Lets face it – your aunt Mildred is more likely to buy you a copy of Batman for your birthday than a copy of Robot Cucumbers from the Planet Xrythh, because she's got some idea what she is getting with the former. You are of course right that what matters in the end is the quality of the software.

### BLEEPING MAD!

I own an IBM PC, and some of the games for it look brilliant. But, the sound... Bleep Bleep. It's driving me MAD. I was reading one of your reviews and you mentioned various sound cards. Please, please, please tell me more.

**John Cooper, Cambridge**

• We know just how you feel John. PC games are great in every other department – great graphics, great gameplay, and then, for sound effects, a horrible squeaking that sounds more like a demented mouse than a Mk.V Super-Freighter entering hyperspace. Fortunately there is a solution – several in fact. A number of manufacturers produce add-on sound cards. These slot into a spare expansion port like any other card, giving you the sort of sound facilities found on other 16-Bit machines (or better).

Two of the best supported boards are: Game Blaster, £130 from Creative Labs, and the AdLib card costing £150. Both of these are available from specialist computer stockists (shop around for the best prices).

### OUT OF PROPORTION

I was recently in a local department store when I noticed something I have been searching for ever since I purchased my computer several years ago. A proportional control joystick which acts like a mouse, the more you move the stick to, say the left, the more the object would move to the left.

Unfortunately the stick I saw was for the IBM PCs and compatibles and I have an Atari 520ST.

Do you at ACE (in my opinion the best computer magazine around) know of a company who makes such a thing for the Atari mouse port?

Also could you please tell me about the current situation with Damocles. Whenever I go into my local computer shop and ask for the above, the assistants tell me I'd be lucky to get it before the turn of the century!

What Has happened?

**Mr. D. Lavercombe, Norwich**

• Unfortunately it is not possible to make an analogue joystick function in such a way that it replaces the standard Atari Mouse. The only alternative that will work is a Graphics Pad, and any Atari stockist should be able to provide you with more details of those currently available. You might want to consider upgrading your ST to an STE. This model has two additional ports

## A VISION OF VIOLENCE

I have been reading your magazine since issue one, some thirty odd months now. Each month you have brought to my attention new developments in the industry – consoles, CDI, interactive this, interactive that, virtual realities.

Initially I was bowled over and stunned by the ever increasing complexity of these technical wonders. Then one day, I wondered what use it was all going to be put to.

Imagine it... The year: 2020 AD

The place: An average home

A room designated to computer entertainment.

A lone child of 13 years, is dressed in a full black body suit, all wired up to the latest home computer, primarily designed to create totally artificial 3D worlds. On his person he carries an electronic gun.

"Moving along the damp alleyway somewhere in New York, the smells of a kebab shop's kitchen mix with the sounds of the night. Steam rises from the ground. A lone figure appears before me. His distorted face, hideously ugly, demands my wallet. I reach inside my jacket to retrieve it, but instead I grab my gun, which I now have held to his face. I force him against the wall and laugh at his now terror stricken features. While I laugh my trigger finger tightens...

I walk away. No one looks. No one dares to, for I am covered in another punk's blood – another trophy."

This juvenile fantasy could well become a reality for my children. I will remember the good old days – Op Wolf, my trusty CPC, my fun, my entertainment, my ability to walk away for my tea. These kids will never walk away, they will be trapped in their own artificial worlds.

You might think I have over exaggerated the potential danger. If you do, then think again. I believe the future of home entertainment is no longer geared towards fun and enjoyment, but towards ultimate involvement, atmosphere, surroundings. Is this what we really want? The more advanced the equipment, the more 'real' the opponent. There was a debate not so long ago, about games like Op Wolf, their violence and the effects of that violence. What might the effects be of the imaginary game I have outlined above?

Sure, all this electrical wizardry could be put to good use. The same 13 year old kid could be 'physically' exploring an accurate representation of an African village, for instance. But if that sort of program was ever going to sell then it would be available now for my Amiga. But it is not what the consumer wants, and I doubt if it ever will be.

So onwards the industry plods, towards it's aim of ultimate interaction. True, there's no point going backwards, but lets not forget that education can be fun as well as senseless violence. Lets not get so engrossed that we forget the constructive potential of our computers and consoles. But most importantly let us never forget the greater responsibility that goes hand in hand with ever advancing technology.

**Paul Kerslake, West Glamorgan**



which do support analogue joysticks.

For all you Damocles watchers out there – your sleepless nights are over. By the time you read this both ST and Amiga versions of the game will be in the shops – and that's official.

**NOT SO HOT CD-I**

As an avid reader of your magazine, I greatly encourage and enjoy your increasing coverage of interactive media. However, in the case of the forthcoming Philips CD-I unit, you are giving a greatly misleading image. In reality, it isn't anything like you make it out to be, especially not a full motion video interactive entertainment system, as you will see:

1) Its Motorola 68020 CPU is in no way powerful enough to handle full colour, full-screen, full motion video, (which represents at least 15MB/s processing), and will be obsolete by the time the machine is launched anyway (more so due to the recent release of the 68040).

2) Its graphical user interface is based on some ancient Tandy computer's OS, and isn't ideal for such a system.

3) Full-screen motion can only be performed for a few seconds. To maintain it for any length of time, as will be needed for most software, the animated area will be no more than 100 pixels square or similar.

4) It needs a dedicated system on which to run CD-I discs. You won't be able to run, for example, Sesame Street on a PC with CD-ROM.

5) The fastest it can do is 10 frames/second at a 384x280 resolution with 128 colours – not exactly a leap into the future and VERY jerky video/animation.

This level of interactivity in this quality of video was already available on the cumbersome BBC Domesday for four years. Apart from superb multi-lingual sound, this has broken no new ground (more like retreading old wasteheaps) I am now personally convinced that DVI is the future. Cool 30 frames/second from a CD-ROM drive, (even people without CD-ROM drives will get 10 frames/second in full colour if they've got a 40 meg hard drive) full screen motion and colour with interactivity is already possible on 286 PCs and above. At the moment it's around £1599, but should come down soon. And it has Big Blue's full support – this is the way to an interactive future.

**Manu Kumar, London**

• The points you make are perfectly valid, but let us not forget one

important factor. The Philips CD-I system is still in development, and the current specification may not accord with the specification of the final device. Despite any limitations the machine may have, Philips should be congratulated and encouraged for investing time and money in a new technology, rather than for the market to become established, as many firms will do. Somebody has to do the groundwork. As to the future of DVI, only time will tell...

**PIECES OF EIGHT**

I would just like to say what a disgrace it is that some companies are letting down their 8-bit customers by not producing games for their machines. Admittedly it is not possible to convert some 16-Bit games, but just look at some of the seemingly impossible conversions which have been achieved, such as *Virus* and *Hard Drivin'* to name but two.

I must congratulate Domark (the ACE conference hosted by Domark was excellent by the way) on producing 8-bit versions of all their games and I hope other companies will follow their lead. If companies stop producing 8-bit games, it will reduce the number of new computer owners (parents are less likely to buy their kids a console than a computer, which can also be used for school), as not everyone can or will splash out £300 on a computer.

The 8-bit market is not dead, but some companies are intent on killing it.

**Michael Brannan, Bedfordshire**

• You are right – the 8-Bit market is not dead. Around 50 per cent of the product shipped by large companies like US Gold and Ocean is for 8-Bit machines. I think you are doing a disservice to the software producers to say that they are deliberately killing off the 8-Bit market. No firm deliberately goes about reducing its own potential market – that would be silly. When companies stop supporting 8-Bit machines it will be because it is no longer financially viable for them to do so. That is inevitably going to be a universal trend at some stage, but I don't think 8-Bit owners have too much to worry about just yet.

**SINGLE SIDED SUCCESS**

Thank you for publishing my letter (*Single Sided Blues*, Issue 30) about games on the ST being on single-sided disks, thus causing a lot of otherwise unnecessary disk swapping. This letter is just to tell you that some good did come of it. I received a letter from Mr. Terry

Morris of Activision saying "Thank you for your comments concerning single sided disks. However, the majority do still have single sided disk drives. But, having said that, with some of our titles we will make disk No.1 double sided while supplying a second disk for people with single sided drives. Therefore, everybody should be happy."

I would like to thank Activision for addressing the problem, and hope that other software manufacturers take notice too.

**Philip Hall, Harleston, Norfolk**

**CDTV IS BRILLIANT...**

I just picked up your latest issue (number 34) and was prompted to write after seeing the two big surprises – the Amiga CDTV and the Neo Geo console.

The CDTV looks great and will probably change the face of computer entertainment, so your coverage of CD-I was justified. But the CDTV will probably destroy any chances the other CD-I machines had of selling.

Amiga owners should feel pretty smug. They now have an upgrade path to CD-I while ST users are still awaiting the arrival of the Atari Laser Disk unit.

The price of the Neo Geo is £425, which seems fair, but the software is £230 per cartridge. Who is going to pay that sort of money for one game?

**G.Laird, Loughborough, Leics.**

• We're glad that you are finding our CD-I coverage interesting, and we agree with your assessment of the CDTV as a revolutionary new development. Remember though, that the market for CD-I is likely to be a rapidly growing one, and there will be room for more than one company and more than one machine. As good as the CDTV is, it is unlikely to have a monopoly for long.

Yes, the Neo Geo cartridges are prohibitively expensive. The idea is that dealers will be the major buyers, and they will rent the cartridges to the general public. Having a Neo Geo in your home will be like having any number of arcade machines at home for a couple of pounds a night.

**SOME SOUND ADVICE**

Recently my son was contacted, out of the blue, by telephone to ask if he was interested in some computer games (Megadrive) at a much reduced price. We became suspicious when the boy concerned told us that we would be unable to ring his number because the telephone

was faulty!

I tried to devise a fair method of safeguarding both parties involved. I came up with the letter below. It may be in the interest of ACE readers to use it when dealing with unknown individuals!

**Tony Norris, Manchester**

P.S. Needless to say we did not get our £10 megadrive games and the cheque was stopped.

The Letter:

Dear XXXX,

Re: our recent telephone conversation and the cheap software you are offering. Because I did not want to send such a large amount of money without some sort of security I have enclosed a post dated cheque for the agreed amount. If I do not receive the games by the date on the cheque I will know that you have changed your mind and I will stop the cheque. If the games are received then the cheque will clear normally.

I think this method is safest for both of us. If you do not have a bank account and would like to put the cheque into a **trusted** friend's or a family account, then just sign the back of the cheque.

Yours sincerely,

XXXXX XXXXX

• This is a very good idea Mr. Norris, and one which ACE readers buying second hand software by mail would do well to take note of.

Needless to say, if you suspect that the software you are being offered is not original, do not buy it. Instead contact Bob Hay of FAST (Federation Against Software Theft)

**HAVE YOUR SAY!**

ACE would not be the magazine it is if we made a habit of ignoring our readers. We are always interested to know what you think, and the letter pages are the part of the magazine where you can have your say on any subject connected with Advanced Computer Entertainment. So don't keep mum – if there is something on your mind let us know at:

**ACE Letters,  
Priory Court,  
30-32 Farringdon Lane,  
LONDON. EC1R 3AU**

Remember that you could win our £25 prize too!

Disponible dans les FNAC et dans les meilleurs points de vente

# UNREAL

“Best arcade game on Amiga” GEN 4

ENTER THE MAGICAL WORLD OF UNREAL  
AND OVERCOME THE ALL POWERFUL  
MASTER OF DARKNESS !



FIVE different types of INTERACTIVE MUSIC along with incredible sound effects, such as the rushing waters of a river, the crackling of fire...

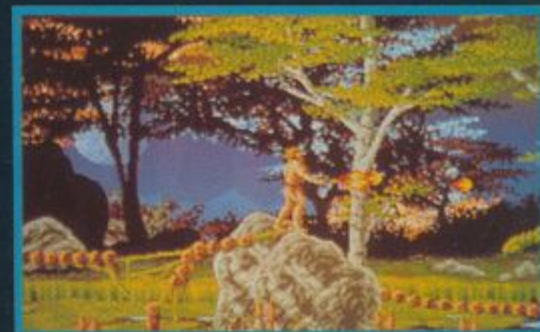

“A completely INTERACTIVE environment: feel free to run and jump up and down hills, but be careful not to slip on the snow and ice or be blown off a cliff by the wind !



Stunning TWO and THREE DIMENSIONAL graphics. A VARIETY of monsters, dragons and bizarre enemies with their own strategies and different weapons.



**UBI SOFT**

8-10, rue de Valmy  
93100 MONTREUIL SOUS BOIS  
Tél. (1) 48 57 65 62

Disponible dans les FNAC et dans les meilleurs points de vente

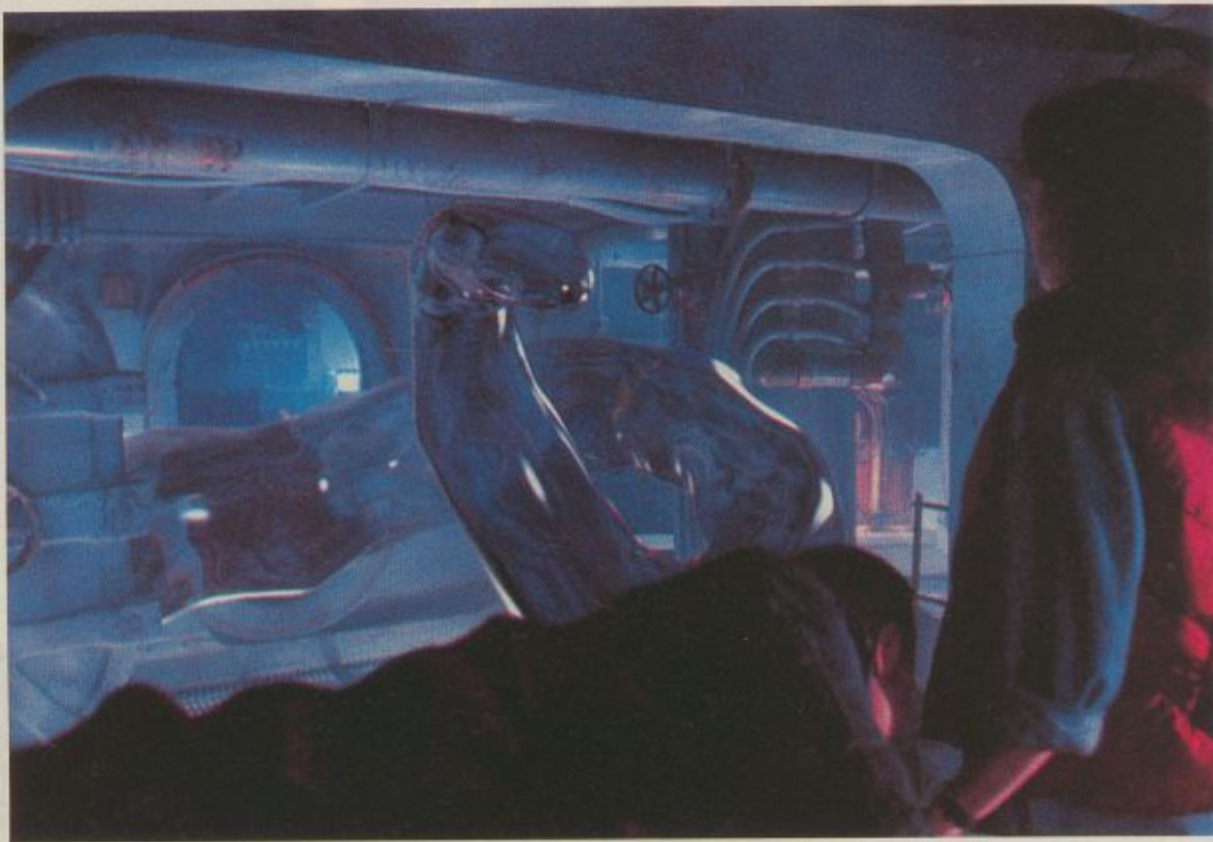

Computer graphics come of age. Here, in a shot from Lucasfilm's *The Abyss*, you see a creature made of seawater. The reflection algorithms that give the beast its realistic appearance were generated using Renderman technology under license from Pixar. Soon software companies will be able to reap similar benefits from adopting Pixar's technology.

# Total Reality?

**D**isney's doing it. Lucasfilm are doing it. And now Pixar's doing it. Suddenly the big names in film and video are looking at the games industry and getting excited. And in the case of Pixar it means the development of games beyond our imagination...

Based in San Rafael, Pixar are a world famous Academy Award winning animation studio. They're now looking at the PC, Amiga, and Macintosh as a platform for their work – and the benefits will soon be felt by owners of other machines when their know-how is adopted by other software houses.

Now that we can look forward to more advanced graphical computer entertainment, thanks to CD technology, people keep wondering what sort of games we'll be playing on the new machines. The Pixar story is a good pointer to what we can expect.

## TAKE ONE

The Pixar screenplay starts – as many film entertainment stories do, with a close-up on George Lucas of 'Star Wars' and Lucasfilm fame. Ahead of his time, Lucas was acutely aware of the potential of computers for film production and formed a Computer Division within Lucasfilm to exploit that potential. 'The goal,' recalls Steve Upstill, one of Pixar's leading graphics programmers, 'was to use computers to produce computer generated imagery that

could share the scene with live actors and sets, yet appear perfectly natural.' Thanks to the efforts of that division, that goal has now been largely achieved – see the shot elsewhere on this page.

Pixar grew out of the Lucasfilm division. After their original formation within Lucasfilm in 1979, Pixar founders Alvy Smith and Ed Catmull brought together one of the largest teams of software and hardware graphics experts in the world. Their research was applied, initially, to the production of special effects in films. Check out *Star Trek II – The Wrath of Khan*, *The Return of the Jedi*, and *The Young Sherlock Holmes*, and you'll find evidence of the team's efforts.

However, the potential of advanced graphics applications seemed to spread far beyond the film industry. As a result, the computer division was spun off as a separate company in 1986. By this time, the team were developing powerful graphics processing techniques, state-of-the-art graphics processing hardware (the Pixar Image Computer), and the creative development of some superlative animations. *Tin Toy*, already featured in ACE, received an Academy Award for the Best Animated short film in 1988.

Best of all for us gamers, however, was that Pixar had a further goal to accomplish – '...to make the tools and systems that would let thousands of people create photo-realistic pictures of whatever they chose to design.' The first out-

Wouldn't it be nice if we could play games that took place on Mars, but looked as real as Leicester Square? ACE went to California and discovered a revolution in computer graphics that could blast gameplay into a new dimension of graphic glory...

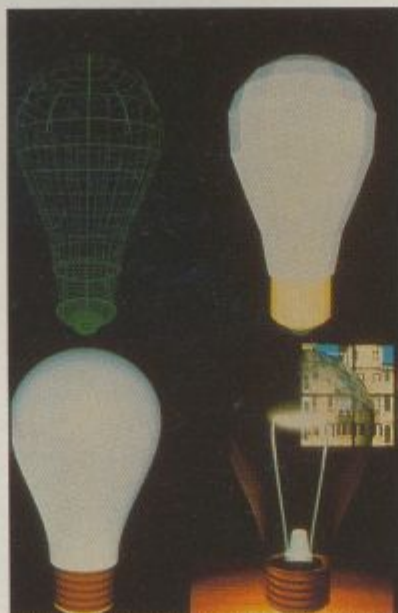

Four different stages in the graphics process. Top left, a polygonal image created using modelling software such as Sculpt 3D. Top right, the image with shading information (the limit of most modelling software). Bottom left, Renderman smooths out the curve. Bottom right, Renderman adds texture and light-source information and seamlessly blends in another bitmap.



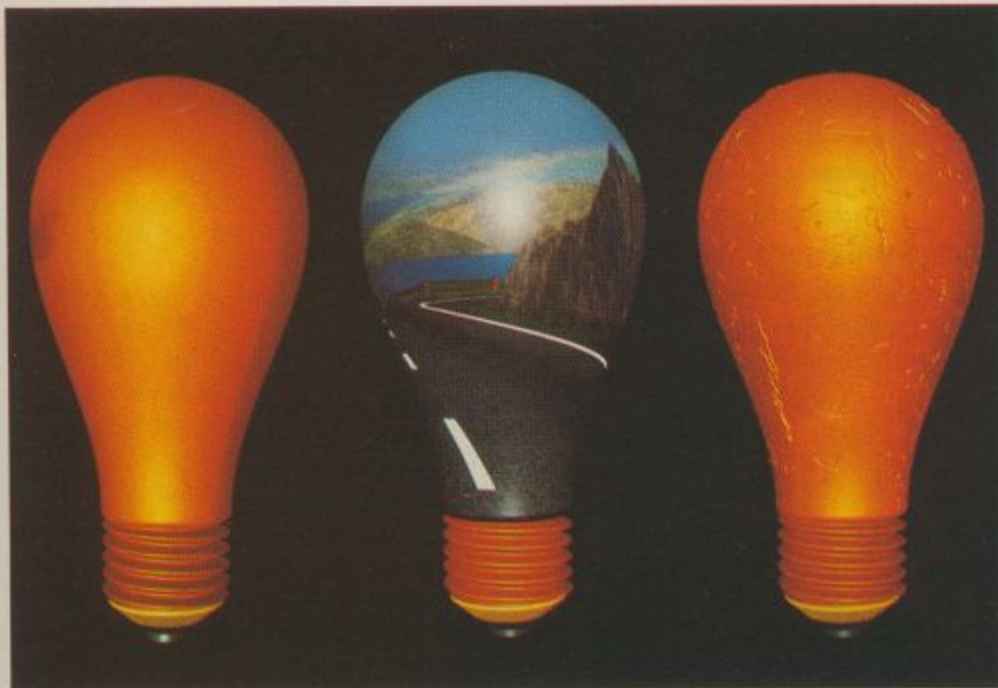

Three lightbulbs rendered as: copper, using the `METAL0` shader (left); textured plastic `TEXTPLASTIC0` in the middle; and a pitted metal surface on the right using `PIT0`. Note that *Renderman* technology also handles lightsource information: the shot below shows the bulb again, in an image mimicking a slide projector using `SLIDEPROJECTOR0`.

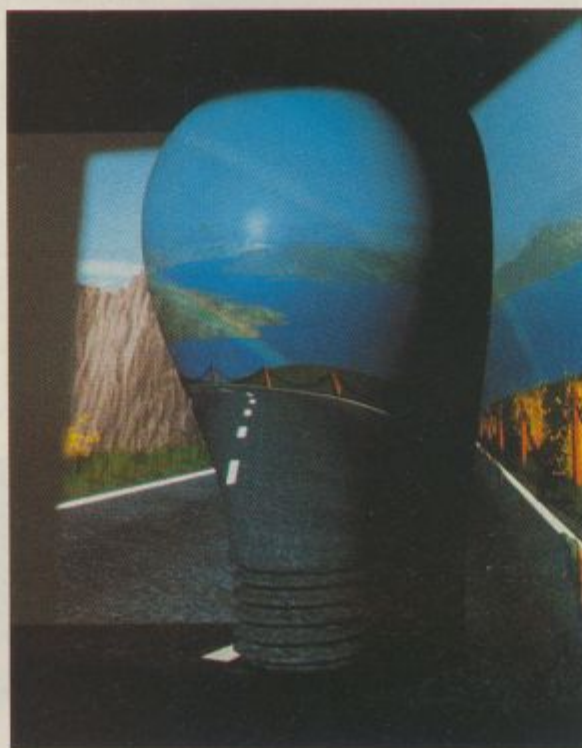

The *Renderman* graphics language includes special commands that can mimic real world textures. In this image, you can see the use of the shading commands `WOOD0`, `DENTED0`, `BLUE_MARBLE0`, and `GRANITE0`.

come of this intent is *Renderman* – an extraordinary product that bridges the gap between computer graphics and real-world images. Here's what it's all about...

#### TAKE TWO

There are basically two different ways to construct pictures on a computer: graphics and imaging.

We normally use the term 'graphics' to cover anything appearing on a computer display, but this is actually inaccurate. In specialist terms, graphics are pictures created on a computer. At the lowest level, they are freehand drawings produced using a package like *Deluxe Paint* or *Neochrome* – simple pixel bitmaps and sprites. Many games use these techniques to build up screens and animated characters. The advantage of this form of graphics is that you can include as much detail in your image as you like. Games like *Shadow of the Beast* and *The Pawn* show what you can do by 'painting with pixels'. The disadvantage is that the images are fixed. If you try to enlarge them, they simply stretch, losing detail in the process. You can't rotate them, because they're two dimensional.

These disadvantages are overcome by 3D graphics technology where the picture is constructed from geometric graphic shapes (called 'primitives') which, because they are defined mathematically, can be scaled, rotated, and otherwise manipulated. These techniques allow you to produce games like *Starglider II* and the *Freescape* titles. Unfortunately, anyone who has compared a screen from, say, *Elite* with one from *Xenon II* will have noticed that what you gain in manipulability, you lose in detail. 3D gamescapes often look starkly geometrical and lack the life-like appearance of a good bitmap drawing.

This conflict between bitmaps and images constructed using graphic primitives (often referred to as vector graphics because of the lines – vectors – used to define the primitive polygons) still bedevil game designers. The shot in this article of *Empire's Let Sleeping Gods Lie* is a good example of an attempt to resolve that conflict.

The other way to create a computer picture is through imaging. Unlike graphics, which are constructed by hand, imaging deals with digitised representations of the real world. In games, this tends to mean scanned photographs or digitised video images. It can also include, however, satellite images, sonar data, and medical CT scans.

Imaging has some big advantages, as anyone who's played a game with digitised backgrounds will know. A scanned image or a digitised video still can give you a real-world accuracy that can look very impressive. But these image bitmaps, although created differently, still suffer from all the disadvantages of their graphics bitmaps counterparts – they can't be easily manipulated.

Wouldn't it be nice if we could get pictures that had the vividness and detail of real world images, the creative power of freehand graphics, and the manipulability of 3D graphics primitives. In short, wouldn't it be nice if we could play games that took place on Mars, but looked as real as Leicester Square.

Hold your breath – here it comes...

#### RENDERMAN

*Renderman* is a unique product from Pixar, developed for the PC and the



*Empire's Let Sleeping Gods Lie* was an interesting example of a game that tried to overcome the limitations of vector graphics and bitmaps – by using both. Unfortunately, just as you get the advantages of both techniques, you also get both their disadvantages.



Renderman power. This entire image was generated algorithmically. The waves are a complex texture pattern and the shading, light-source, and other elements were all defined using the Renderman graphics language.



Macintosh but currently under consideration for the Amiga as well. Furthermore, it's a product that other software companies can purchase 'off the shelf' and use to generate graphics displays that could then be converted onto other machines. The technology it uses will soon benefit all gamers.

Basically, *Renderman* creates a bridge between the limited world of 3D graphics and the limitless detail of real-world images. It retains all the manipulability of vectors but adds photorealistic display and output capabilities. In short, it can take a disjointed, polygonal alien monster and turn it into a nightmarishly realistic beast that looks as if it had been captured on film by an interstellar safari photographer.

As part of Lucasfilm Ltd, the Pixar team had developed software algorithms for assigning (or 'rendering') color texture, volume shading, depth of field, and motion blur to 3D generated computer models. These attributes make the difference between a flat, lifeless 3D image and a vivid real-world appearance.

Take surface texture, for example. Currently the only way for most people to assign texture to a surface is to either create or capture the texture as a pattern and then 'wrap' it onto the surface of the graphic object, rather like applying a transfer. Like a transfer, however, this bitmap cannot be stretched or manipulated without distorting it.



Steve Upstill, master *Renderman* programmer, outside the Pixar offices in San Rafael, California

*"Renderman is the ultimate graphics tool. Just as Postscript describes a page, so a file output by Renderman describes a displayable image. From the word go, Renderman was conceived with quality in mind."*

Steve Upstill, *Renderman* programmer

### THREE STEPS to 3D ANIMATION

There are three steps to producing a production quality computer animation. Here's the procedure...

- First, you need to *model* the objects and elements involved. This involves creating a description (in mathematical terms) of the object - its dimensions, curvature, number of faces etc. There are many 3D modelling packages on the market... *Sculpt 3D* is a good example.
- After creating the model, you need to animate it. This involves defining the movement patterns of the model - as you can do in a package like *Deluxe Paint III*. This is much more complex than you might think - see the shot below.
- Finally, you need to *render* the image. This involves the computation of light sources, surface shading and texture. It is this stage that *Renderman* is concerned with. *Renderman* takes a file defining the model and assigns display characteristics that enable a production quality frame to be constructed. Calculating the lightsource and texture information is extremely complex and can take literally hours for each frame.

One way to do it is to create the texture as a polygonal 3D graphic, but the level of detail required is so enormous that the sheer number of polygons involved is going to weigh down any conventional processing system to the point where it packs up completely.

*Renderman*, however, applies to texture the same mathematical approach that a program like *Sculpt 3D* applies to the modelling of 3D objects. The program uses a special graphics language that enables programmers to mimic real world graphic elements. You can see the results in some of the shots in this article.

Graphics programmers can now create graphic primitives and then process them using *Renderman* to achieve astonishingly realistic results. So does that mean that we will be seeing real worlds coming to life in our games in the near future?

The problem we have to overcome is processing time. *Renderman* images take hours to compute on a small computer. However, Pixar can get round this by producing a scaled-down version of the technology that will run faster at lower resolution. It won't completely solve the problem but it will help.

Probably the most useful aspect of the system, however, is its potential for CD-based systems. *Renderman* programmers will be able to generate frames that can be stored on CD for animation purposes. Realistic backgrounds can also be created. This means that owners of the Commodore CD-TV could soon be able to play games with graphics undreamt of only a few months ago. Even standard computer games will benefit from having backgrounds that combine manipulability (limited by processing power) with enormous detail. The computer-generated universe is not only closer than you think. It also looks more realistic than you ever dared hope.

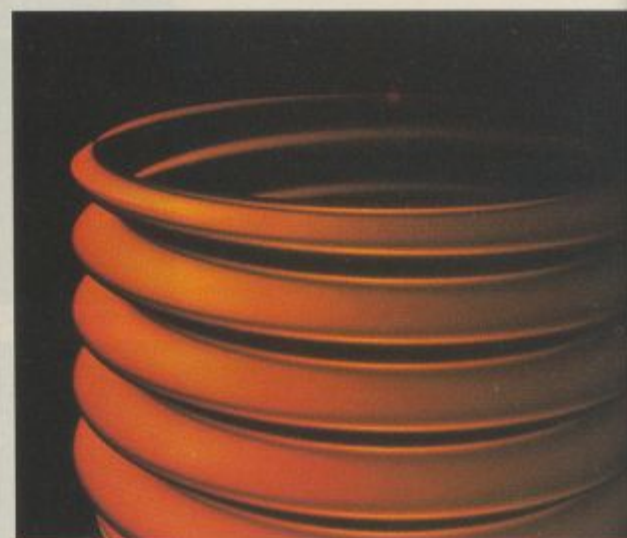

Textures are algorithmic in *Renderman* and go far beyond simple surface variation. Here shading commands are used algorithmically to generate complete structures. Here's a close-up of the bottom of the bulb pictured elsewhere in this article - the thread is not drawn, it's generated.

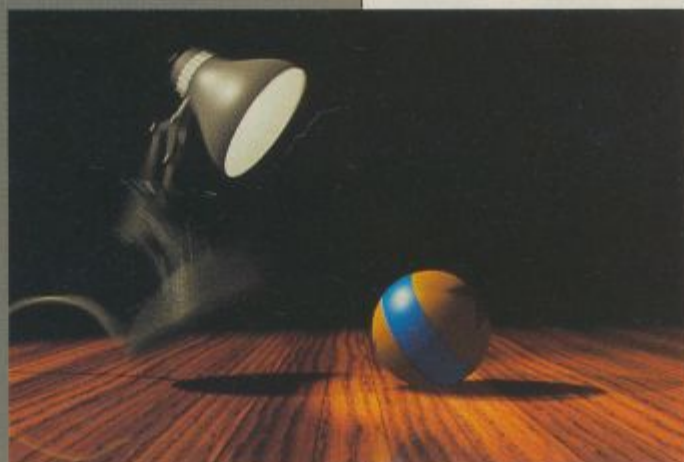

This is a scene from an animation in which the frames were computed using *Renderman*. One of the principal abilities of the package is the calculation of 'motion blur'. This technique imparts a blur (see here) to a moving object so that, when frames succeed each other in an animated sequence, the object appears to move smoothly. Previously, animators used literally to 'jiggle' the objects with sticks while holding the shutter open to blur their images on the film - a technique called by Lucasfilm (who developed it) *GoMotion*. *Renderman* achieves a similar effect in software.

# UMS II

## NATIONS AT WAR

**Universal Military Simulator**

**was**

**the definitive battle strategy  
game.**

**Where it led others tried  
to follow.**

**Now Rainbird are set to  
re - write history  
again.**

**UMS II - NATIONS AT WAR.**

**The whole world at your fingertips.**



**MASTERS OF STRATEGY**



Five, four, three, two, one. Thunderbirds are go! Activision is resurrecting the Gerry Actric puppets in a new NES game which features "detailed splash screens", Mach 20 Thunderbird 1 rocket, Neptune Hydro-Turbo Jet, Fire Flash Atomic Plane, poisonous space scorpions and deadly sea-worms.

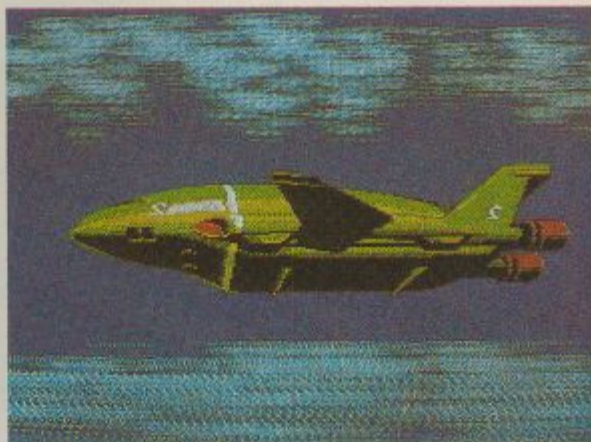

**DAYS OF THUNDER** by Mindscape. Based on the new Tom Cruise movie from Paramount Pictures, this racing game is due to be released on Nintendo NES and Gameboy, Amiga, ST, PC, Spectrum, C64 and CPC this Christmas. The NES version of 'the Top Gun of car movies' features eight different races on seven different race tracks and a pit crew to change tires, make repairs and refuel. "Lay it on the line."

The Laser Scope Voice Command Stereo Headset from Konami is the latest cyber peripheral for the Nintendo NES console. This lightweight headset allows you hands-free control of your games. You direct fire by moving your head and lining up your 'electronic scope' with the target. The firing sequence is then activated by voice commands. The tech is straight out of the cockpit of an Apache helicopter gunship. This \$39.95 'headstick' is compatible with all existing Zapper games - plus the ones currently in development. "Get totally involved in the synergy between man and machine."



# Prepare for Invasion

**W**hat is the Summer Consumer Electronics Show? What has it got to do with Advanced Computer Entertainment? Why doesn't ACE cover the 16-bit Computer Fair instead?

The Summer and Winter Consumer Electronics Shows are the biggest and best electro exhibitions outside Japan. From CDs to camcorders, DAT to Digital TV, video games to VCRs. If it's electrical, consumable and out in the shops by Christmas - it's at the Summer Consumer Electronics Show. In the light of these facts, it's easy to see what this has to do with Advanced Computer Entertainment. Everything. Here's a quick glimpse of what went down in Chicago.

So what new gadgets and games are going to invade our shores over the next six months?

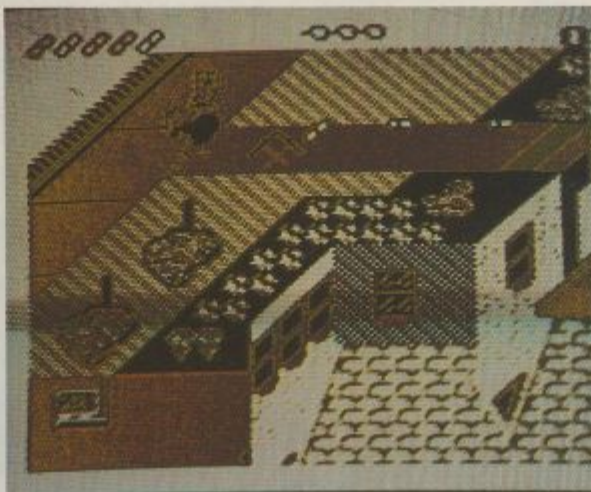

**PAPERBOY** by Mindscape. One of the most original coin-ops of all time is due to be released on the Gameboy this autumn.

**Rik Haynes** replays the best from the recent Summer Consumer Electronics Show



**DIRTY HARRY** by Mindscape. "Do ya feel lucky? Well, do ya, punk?" Dirty Harry is due to hit silicon this Christmas on Nintendo NES, Amiga, ST, PC, Spectrum, C64 and CPC. The NES game features multiple levels of play including shoot-outs in streets and alleys, search and seizure in rundown buildings, slimy surprises in sewers and a final showdown in Alcatraz. "Go ahead. Make your day."



## TOO LITTLE, TOO LATE

Atari's Lynx, the world's first colour hand-held console, looked a little limp against the competition from the Nintendo Gameboy and NEC TurboExpress. Put bluntly, too few games are available for the Lynx. Tengen is the major supplier of Lynx games with titles including Klax, Paperboy and Road Blasters. In addition, Xenophobe, Rygar and Rampage are due to be converted. Breakout, American Football and World Cup Soccer games are also being developed. Unfortunately, Lynx owners must wait for these much needed games carts because they won't be released until the end of the year or even early '91

## THE WORLD OF NINTENDO

If a thing's worth merchandising, it's worth merchandising right. Here's a brief list of the Nintendo inspired goodies on sale in Stateside supermarkets: beach towels, kitchen textiles, placemats, bathrugs, wood cartridge holder, plastic play sword, moulded character water squirts, plastic mugs, satin Christmas ornaments, plush chairs, character inflatables, 2D key chains, plush dolls, lunch kits, wooden folding tables and trays, plastic light switch plates, nightlights, edible cake top decorations, 3D moulded lollipops, tableted candy, stickers sold in vending machines, latex balloons with digitised images, punch balls, playballs, bookmarks, door hangers, bookcovers, pocket calendars, collector books, comics, diaries, address books, photo albums, scrapbooks, autograph books, PVC figures, pencil toppers, pencil huggers, pencils, pencil sharpeners, magnets, linticular stickers, snowdomes, paper bags, posted note pads, ceramic mugs, nylon wallet, children's beds, night tables, desks, bench, chest, gift wrap, paper party goods, chocolate bars, jelly candies, footwear, popcorn, mirrors, waste baskets, paper lunch bags, plastic game cartridge caddy, drinking canteen, Super Mario moulded phone, Super Mario Bros. super birthday party videotape, swimsuits for boys and girls, sleepwear, beachrobes for toddlers, beach blanket anchors, wall clocks, keywound double bell alarm clock, sleeping bags, quilted patterns, cookies and crackers, ice cream sandwiches, frozen pudding pops, frozen juice pops, ice cream bars, ice cream in cartons, directors chairs, sheet music for concert and marching bands, trophy figures, knitted socks, backpacks, gym bags, duffel bags, wallets, canteens, theme books, memo pads, belly bags, softsided luggage, insulated lunch bags, character shaped plastic straws, wrap around plastic insulated beverage holders, puffy stickers, bubble toys, battery operated toothbrush, jumbo plastic gift bags, play a tune book, embroidered and iron-on patches, nylon jackets, etc...

LJN is producing A Nightmare on Elm Street, Back to the Future Part II & III, Who Framed Roger Rabbit, The Punisher, Beetlejuice, Bill & Ted's Excellent Adventure and Pictionary for NES - and The Amazing Spiderman and Beetlejuice for Gameboy.



ROBOCOP by Ocean. The most successful computer game of 1989 is now being converted to Gameboy in 1990. Ocean told us they're using the original Spectrum graphics as a base for the Gameboy's visuals!



THE LAST NINJA on the NES by Jaleco. System Three's classic C64 arcade adventure has been Nintendo'd.

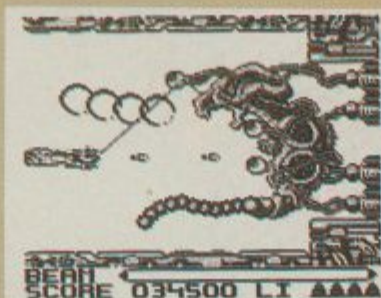

R-TYPE by Irem America. R-Type on the Gameboy was one of the many examples of the excellent range of games being converted to this leading handheld console.

M1 Tank Platoon, Vette, F-15 Strike Eagle, 688 Attack Sub, Hard Drivin' and Klax are all being converted over to the Sega Genesis/Megadrive.

*"Genesis does...  
you can't do this  
on Nintendo!"*  
Sega's inane and infuriatingly infectious singa-longa-slogan

## LEARN TO PLAY THE PIANO

Mindscape's Miracle Piano Teaching System for the Nintendo NES was launched with the help of Dudley Moore. The Miracle System combines a special cartridge, advanced electronic keyboard and artificial intelligence software. The Miracle Piano Teaching System takes a child or adult through a series of carefully customised, progressive, video-based lessons. "The Miracle System's full-stereo sound and stand-alone MIDI keyboard will have anyone playing one and two-handed melodies within hours." Using Miracle you'll learn real music notation, proper fingering techniques, how to read and play rhythm properly, how to teach yourself a new piece of music and pedalling.

Les Crane, Chairman and CEO of The Software Toolworks, explained, "We believe that it will attract everyone from novice players to formerly accomplished pianists who wish to refresh their skills. The keyboard alone is on par with the premier MIDI consoles available."

The Miracle Piano Teaching System costs \$299.95 and features over 100 instruments and sound effects, artificial intelligence used to customise lessons to meet your individual musical needs, a musical repertoire of over 100 songs (classical, rock, standards, show tunes and even materiel written by a Grammy award-winning composer), fun lessons (with video games, historical facts and computer accompaniment), built-in stereo speakers, foot pedal, earphones, MIDI-in and MIDI-out ports.

## MUSIC TO YOUR TURBOGRAFX

Warner New Media is producing a series of interactive compact discs with graphics (CD+G) for NEC's TurboGrafx-CD player. The first PlatinumTrax title is due in the autumn. Tentatively named Loud Guitars, it contains four channels of graphics and narration that trace the history of the electronic guitar. It will feature Chuck Berry, Van Halen and Jimi Hendrix. You can access interviews with the artists, extensive graphics commentary and additional music from animated menus. Warner New Media is the pioneer of CD+G technology and currently has more than 50 CD+G titles.

### CHICAGO BEATS

1. Bizarre Love Triangle by New Order
2. Vogue by Madonna
3. Express Yourself by Madonna

### CHICAGO CLUBS

Baja Beach Club - rednecks, brits on the piss, karaoke  
Excalibur - sexy girls, easy women, karaoke

Enix in Japan sold 1.3 million copies of its Dragon Quest IV NES game during the first day of release.

Ocean has signed up the movie Fire Birds - "a sort of Top Gun with helicopters"



# POWER UP OR PULL OUT!

# MIDNIGHT RESISTANCE



**DATA EAST**

**THE "POWER UP" COIN-OP HIT FROM DATA EAST BRINGS SUPER-ACTION TO YOUR MICRO SCREEN.**



*"Graphics are very impressive...all sprites and backgrounds are beautifully detailed...more playable than its arcade parent. Brilliant!"*

Join the resistance fighters in their crusade against the awesome powers of KING CRIMSON - the manic scientist, and his Crimson Corps - mere earthlings transmuted into treacherous fighting machines... giant armoured tanks, lethal circular saws, airborne fighters, mechanized snakes and many more. Each level throws you into confrontation with an enemy even more terrifying than the last. If you have the skill you can locate the weapons of your predecessors' failed missions - if you have the courage you can fight to reach **YOUR ULTIMATE GOAL - THE DESTRUCTION OF KING CRIMSON HIMSELF.** SO, POWER UP AND TAKE ON THE MECHANOID WORLD OF MAYHEM AND ITS LEADER - KING CRIMSON.



**SPECTRUM  
AMSTRAD CPC  
COMMODORE  
ATARI ST  
CBM AMIGA**

**ocean**

Ocean Software Limited · 6 Central St  
Manchester · M2 5N5 · Tel: 061 832 6  
Telex: 669977 OCEANS G · Fax: 061 834

# A License to Print Money?

**P**hone calls, gossip columns, rumours, and fat, fat cheques. That's what it's all about, bro, and never more so than at this very moment. In the Hollywood jungle, the drums are beating as the natives prepare for total war at the box office. Armed with some of the biggest budget releases in recent years, the fat cats are bounding out of the undergrowth and screaming for blood. Some of it, beloved gamester, could be yours.

Yours because that game you bought, licensed from a Hollywood movie, meant a few more pence for the movie machine. And if you thought film licenses were old hat, believe us – you ain't seen nothing yet. If you want to find out what's coming up, just listen to those drums.

Right now, the drums say, watch Dick. Dick Tracey, that is. In some luxurious air-conditioned office, the Big Boy has sent out the word. Dick is going to be big.

"Yes, it's going to be big, alright – a major licensing event," smiles Mirrorsoft agent Dick Lehrberg, seated beside the pool outside his Palo Alto home. "First came the video trailer. There was a big campaign for the video game people. Calls were made to the board game guys, the toys, the party hats, the T-shirts. You're going to see all the power and weight of Disney behind this one – merchandising, action figures, clothing, even a Madonna album."

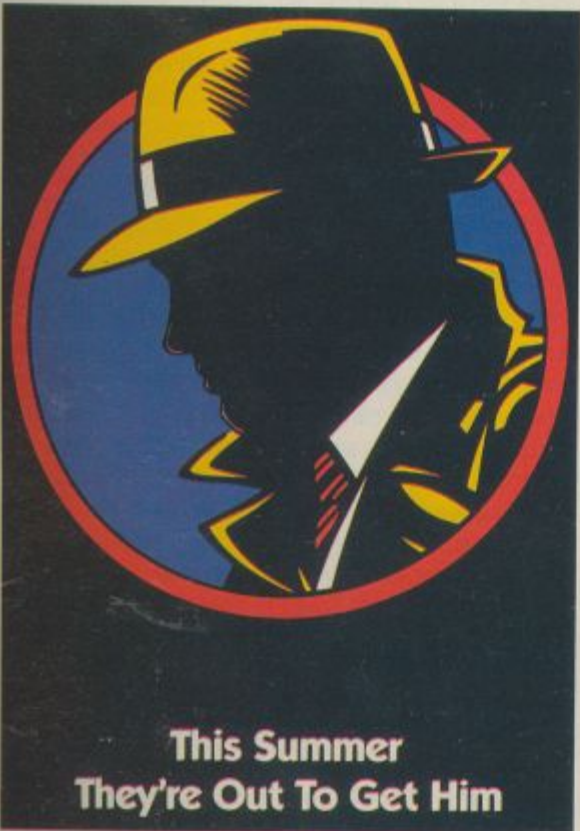

Dick Tracey – this summer they're also out to get your money

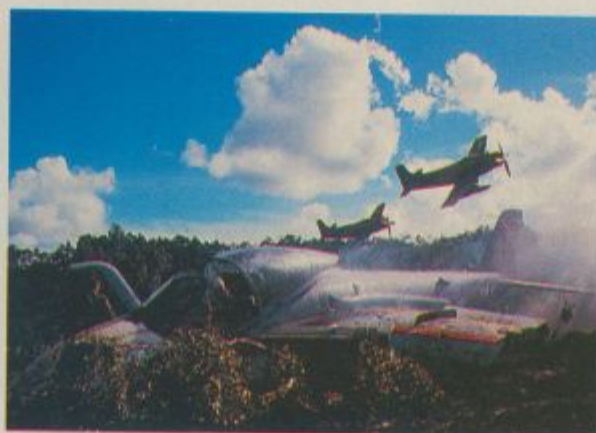

Flight of the Intruder – nabbed by Spectrum Holobyte before the movie boys got hold of it and coming soon from Mirrorsoft

Dick Tracey is just one of a number of mega-releases that are due to hit the screen this year. The result is almost certainly going to be the closure of at least one major studio for the simple reason that there are only so many cinemas in the big bad world and there are too many movies trying to squeeze into them. It's a battle for screen space, box office cash and spin-off revenue. And it's the spin-off revenue that has Mirrorsoft on the phone to Dick (Lehrberg, that is) from London...

'What's cooking Dick?'

'Total Recall took \$25 million last weekend. It's going places.'

'Too late. Ocean got that one. (Muttered curses from both ends of the line) What's the situation on Predator II...?'

Well, we can interrupt that call to tell you that. They've got it. Dick's obviously delighted and thrusts a bulky document into our hands. It's thirty pages of closely packed information telling you why Predator II is going to be a hit. Dick's long experience in the film licensing business (begun at Activision with Aliens) has enabled him to skip the spiel and sift out the nitty gritty...and he's been impressed enough to buy.

'No-one can predict a hit,' he says, 'but there are two determinants you look for from the beginning. First, the director. If he's got several good credits under his belt, you take notice. Then there are the stars. The bigger they are, the better the box-office draw. The whole film business revolves around what people have done before – it's all about resumes.'

We skim through the thirty pages and, yes, it's thirty pages of resume with a potted history of achievement for practically everyone connected with the film. By page 25 you're wondering when you'll get on to the award-winning pot of Earl Grey the tea boy put together for Mr Big in 1984.

'The other important thing,' adds Dick, 'is the High Concept.'

The what??

There's gold in them thar hills. The Hollywood Hills, that is. ACE headed off to the West Coast and challenged Mirrorsoft agent Dick Lehrberg to spill the beans about film licensing. Here's the multi-million dollar story...

## MIRRORSOFT

Four Mirrorsoft licenses are going to hit your small screen this year. Here's the tally:

### BACK TO THE FUTURE II

Due for release on ST, Amiga, and Spectrum real soon now, with C64, Amstrad, and PC versions scheduled for August. The film has been out on general release and the video rental release starts about the time you read this.

### BACK TO THE FUTURE III

Set in the Wild West in the late 1800's, the film is due out about the time you read this. The game is being developed by Probe and should be released to coincide with the video rental release this Xmas.

### FLIGHT OF THE INTRUDER

Not strictly a film license, but a film is coming out at the same time. PC version should be out in July, with ST and Amiga versions following in October

### PREDATOR II

Film hits the States at Christmas, with the UK distribution in the following summer (movies often release up to six months later in Europe).

'Basically, the High Concept is the story of the movie in a single sentence. Take Total Recall, for example. The High Concept there is 'Arnie Goes To Mars'. It's a winner. Or Predator II: 'The Predator Goes To LA And Fights Drugs.' The High Concept is very important.'

**LICENSED TO CASH IN**

Once you think you've spotted a hit, you go for the license. Or do you?

'Not if it's Driving Miss Daisy, you don't, laughs Dick. 'You have to remember that our audience are mostly either pre-pubescent or pubescent males. Driving Miss Daisy may win all the awards, but it isn't going to hit the top of the game charts.'

**DISNEY GOES GAMING**

According to Dick Lehrberg, most film companies aren't that interested in the video game business. But there are exceptions. 'Of the big studios both Disney and Lucasfilm recognise and understand the power and potential of the medium,' says Dick. 'Disney have started their own games divisions and are going to produce educational and entertainment software. Dick Tracy is obviously going to hit silicon, and so will Duck Tales and Rescue Rangers (starring the Chip'n'Dale chipmunk duo). Disney have been particularly - and I think sensibly - cautious by publishing only on computer and licensing out the console rights to other parties.'

Lucasfilm, of course, have been in games for quite some time and ACE readers will be familiar with them from the recent article on Skywalker Ranch in issue 31, not to mention their many games releases ranging from the early Rescue and Fractalus to the more recent Loom and Indiana Jones titles.



Disney are highly successful licensors - characters like Mickey and Goofy make the company millions of dollars a year. Disney have even created the ultimate merchandising operation - two complete cities devoted entirely to displaying and promoting the Disney experience: Disneyland in California and Disney World in Florida, with a third to come outside Paris. Every visitor gets a Disney passport (shown here) and can even change his/her cash into 'Disney Dollars' for use in the shops!

**BOX OFFICE WAR**

Every day, Variety magazine spots the box office trends for the film biz and prints regular listings: here's how the Top Ten releases were stacking up when ACE visited Celluloid City...

FILM	TAKE	SCREENS	AV	TOTAL	RELEASE
Total Recall (Tri-Star)	25,533,700	2060	12395	25,533,700	3
Back to the Future III (U)	10,337,625	2025	5105	38,098,875	10
Bird on a Wire (U)	6,350,305	1963	3235	42,256,355	17
Pretty Woman (BV)	4,755,105	1791	2655	126,741,424	73
Cadillac Man (Orion)	2,885,324	1878	1536	19,598,361	17
Fire Birds (BV)	2,611,812	2006	1302	10,168,398	10
Teen. Mut. N. T. (NLC)	1,953,695	1777	1099	121,026,660	66
Hunt for Red Oct (Par)	1,046,867	933	1122	112,256,167	94
Tales from Dk Side (Par)	560,556	618	907	15,405,624	31
Joe Vs the Volcano (WB)	413,166	566	730	38,169,803	87

Key:

Film: Film (Distributor: U=Universal; BV=Buena Vista (Disney); NLC=New Line Cinema; Par=Paramount; WB=Warner Bros)

Take: Takings over the weekend of June 1-3

Screens: No of screens the film is showing at

Average: Average takings per screen

Total: Total box office takings to date

Release: Number of days on release



Back to the Future III - licensed by Mirrorsoft and pulling in millions of dollars.

The frighteningly violent Total Recall is a biggie: it took more in the first three days than any other movie this year and ranks number nine in the top ten box office weekend takings of all time. It also ranks number three in the non-holiday opening charts, behind Batman and Ghostbusters II. BTTFIII is looking pretty good too - which can't be bad news for Mirrorsoft.

Ocean can't be too happy about the performance of Fire Birds, for which they are believed to have the license. After only ten days in the charts its takings

are already beginning to slip. With films costing anything from \$10 to \$60 million, and the income to the studio from box office revenue amounting to only 60%, Fire Birds looks as if it could end up a turkey. Cadillac Man isn't scintillating either - perhaps it could be the last straw that breaks Orion's back in the Battle of the Studios.

But you can there's gold in them thar hills. Pretty Woman must have made a packet for Disney/Buena Vista and Total Recall, although it was hugely expensive to produce at \$60 million, looks like a whopping great money machine that's only just getting into gear. Watch those cash registers roll.

'The other problem is timing. You can't tell from the script whether a film is going to make it, but you can't afford to wait either. A game takes nine months to produce and if you wait the film is going to have been and gone before the game appears.'

As far as timing is concerned, Mirrorsoft were particularly lucky with Flight of the Intruder. 'Spectrum Holobyte spotted Steven Coontz' book and liked what they saw. They took out the license while it was still a hardcover book. They were lucky because later Paramount saw it as well and decided to make a film of it.'

If you can get in early, the time it takes to produce the film can help the software house do the best possible job. Most films take at least a year to put together. The principal photography usually takes around four months and you can allow almost twice that for post-production work - special effects, sound, editing and so on. In addition there's a good deal of pre-production work involved (casting, scouting locations etc. You can find out more on pages 74/75 of this issue).

Thanks to Dick, Mirrorsoft are now sitting on four very promising film licenses (see box). They cost a bomb (no-one's saying how much, but licenses start at around \$100,000 and work upwards) and there's always an element of risk. You and your joystick will cast the votes - and a small portion of your hard-earned cash will slip across the Atlantic and cast a further vote in the battle of the studios. Deep in the jungle, someone will be counting your contribution...

*"The film and game business are going to get closer together. The Cinemaware product is stage one - and soon the console market, with bolt-on CD drives, is going to open up a new market."*

Dick Lehrberg, Mirrorsoft license agent

PETITION THE COUPON FOR FREE COLOUR BROCHURES!



**RETURN THE COUPON FOR FREE COLOUR BROCHURES!**

# NEW! - AMIGA PACK

Commodore A500  
Flight Of Fantasy  
**£399** INC VAT



## A500 BATMAN PACK



The Commodore A500 Batman Pack must surely rank as one of the most popular computer packs ever! The pack features the Commodore Amiga 500 computer with mouse controller and TV modulator, plus four top software titles. The software includes: 'Batman The Movie' - Rid Gotham City of the cunning joker, in Ocean's top selling title based on the blockbuster Batman film; **New Zealand Story** - high quality conversion of the leading arcade game; **Interceptor** - Dogfight with two F-16's in this leading flight simulator; **Deluxe Paint II** - top quality Amiga graphics package which set the standard for others to follow. Return the coupon for further details.

**PACK INCLUDES:**  
 A500 Computer & Mouse £399.99  
 A520 TV Modulator £24.99  
 Batman The Movie £24.95  
 New Zealand Story £24.95  
 Interceptor £24.95  
 Deluxe Paint II £49.95

**TOTAL RRP: £549.78**  
 Less Pack Saving: £150.78  
**PACK PRICE: £399.00**

**£399** INC VAT

## AMIGA 2000



For the more serious or professional applications user, Commodore have a selection of systems based around the expandable Amiga 2000, at prices from £1295+VAT. The A2000 features a full 1Mb RAM (expandable to 9Mb), 9 system expansion slots, plus IBM compatibility with the use of PC-XT or PC-AT bridgeboards. Complete and return the coupon, putting a tick in the A2000 box, for details of A2000 computer systems.

**£1295** +VAT= £1489.25

## FLIGHT OF FANTASY

Flight of Fantasy is the very latest Amiga 500 pack from Commodore, featuring BRAND NEW software releases, to make this the most spectacular A500 pack ever! The pack features the Amiga 500 computer with mouse controller and TV modulator, as well as four top software titles. These include the following:

**DELUXE PAINT II:** The high quality graphics program that set the standard for other Amiga art packages. Deluxe Paint II includes powerful, easy to use tools that bring out the artist in you. Create masterpieces, presentations, 3D perspectives or just doodle.

**ESCAPE / ROBOT MONSTERS:** Here's something completely different - a science fiction story with comic book style graphics. Our heroes Jake and Duke are on the Planet X rescuing Humans who have been captured by the Robot Monsters and forced to create an evil Robot Army to DESTROY EARTH! Jake and Duke fight their way through hordes of evil Robots to help the Humans escape.

**RAINBOW ISLANDS:** Slip on your magic shoes, practise throwing a rainbow and you're ready to go island hopping. From the Island of Doh to Monster Island, you will encounter Doh himself, stinging insects, lethal combat machines, mechanical assailants, the formidable beings of legend and folklore. Finally enter the world of darkness and its inhabitants.

**F29 RETALIATOR:** The ultimate in flight simulation with a choice of two aircraft and four battle environments with dozens of different tactical missions. Aerial combat, strategic bombings, interactive ground based battles, seagoing carriers... the list of features is endless. Real time cockpit displays, including 'true radar' enhance the realistic feel of this stunning simulation.

**PACK INCLUDES:**  
 A500 Computer & Mouse £399.99  
 A520 TV Modulator £24.99  
 Deluxe Paint II £49.95  
 Escape/Robot Monsters £19.99  
 Rainbow Islands £24.95  
 F29 Retaliator £24.95

**TOTAL RRP: £544.82**  
 Less Pack Saving: £145.82  
**PACK PRICE: £399.00**

**£399** INC VAT

**FOR FURTHER DETAILS OF THE AMIGA RANGE, COMPLETE THE COUPON AND RETURN IT TO SILICA SHOP THE UK's No1 AMIGA SPECIALISTS**

**SILICA SHOP OFFER YOU**

**FREE OVERNIGHT COURIER DELIVERY:** On all hardware orders shipped in the UK.  
**TECHNICAL SUPPORT HELPLINE:** Team of Amiga technical experts at your service.  
**PRICE MATCH:** We normally match competitors on a "Same product - Same price" basis.  
**ESTABLISHED 12 YEARS:** Proven track record in professional computer sales.  
**£13M TURNOVER (with 60 staff):** Solid and reliable with maintained growth.  
**BUSINESS/EDUCATION/GOVERNMENT:** Volume discounts available for large orders.  
**SHOWROOMS:** Demonstration and training facilities at our London & Sidcup branches.  
**THE FULL STOCK RANGE:** All of your Amiga requirements from one supplier.  
**FREE CATALOGUES:** Will be mailed to you with offers and software/peripheral details.  
**PAYMENT:** By cash, cheque and all major credit cards.  
**CREDIT PAYMENT TERMS:** Silica are licensed credit brokers - return coupon for details.

Before you decide when to buy your new Amiga computer, we suggest you think very carefully about WHERE you buy it. Consider what it will be like a few months after buying your Amiga, when you may require additional peripherals or software, or help and advice with your new purchase. And, will the company you buy from contact you with details of new products? At Silica Shop, we ensure that you will have nothing to worry about. Silica have been established for over 12 years, and have an annual turnover of £13 million. With our unrivalled experience and expertise, we can now claim to meet our customers requirements with an understanding which is second to none. But don't just take our word for it. Complete and return the coupon now for our latest Free literature and begin to experience the "Silica Shop Service".

**RETURN THE COUPON NOW FOR FREE BROCHURES**

**SILICA SHOP**

**MAIL ORDER:** 1-4 The Mews, Hatherley Rd, Sidcup, Kent, DA14 4DX Tel: 081-309 1111  
 Order Lines Open: Mon-Sat 9:00am-6:00pm No Late Night Opening Fax No: 081-308 0608

**LONDON SHOP:** 52 Tottenham Court Road, London, W1P 0BA Tel: 071-580 4000  
 Opening Hours: Mon-Sat 9:30am-6:00pm Late Night: Thursday until 8pm Fax No: 071-323 4737

**SIDCUP SHOP:** 1-4 The Mews, Hatherley Rd, Sidcup, Kent, DA14 4DX Tel: 081-302 8811  
 Opening Hours: Mon-Sat 9:00am-5:30pm Late Night: Friday until 7pm Fax No: 081-309 0017

**BUSINESS/EDUCATION:** 1-4 The Mews, Hatherley Rd, Sidcup, Kent, DA14 4DX Tel: 081-308 0888  
 Order Lines Open: Mon-Fri 9:00am-6:00pm Closed on Saturdays Fax No: 081-308 0608

To: Silica Shop, Dept ACE-0890-32, 1-4 The Mews, Hatherley Rd, Sidcup, Kent, DA14 4DX

**PLEASE SEND INFORMATION ON THE AMIGA**

Mr/Mrs/Ms: ..... Initials: ..... Surname: .....

Address: .....

Postcode: ..... Tel: .....

Which computer(s), if any, do you own?  A2000

©1992 - Advertised prices and specifications may change - please return the coupon for the latest information.

# Hooray for

**F**antasy has filled my life, and I love fantasy so much! So sings Jon Anderson in the nostalgic look at movie land, *A friend of Mr. Cairo*. This month, in an exclusive competition in conjunction with Mirrorsoft we are giving you the once in a lifetime chance to live out your fantasies in Hollywood, movie capital of the world.

To celebrate their forthcoming licenses for *Back to the Future II* and *III*, Mirrorsoft will be flying a lucky ACE reader and friend out to sunny Los Angeles to sample all the delights that tinseltown has to offer. While there you will tour the set for *Back to the Future II*, where you can follow in the footsteps of stars Michael J. Fox and Christopher Lloyd.

*Back to the Future II* and *III* are just the first two of some exciting movie licenses that Mirrorsoft has lined up for release in the near future. And who better to bring the glamour and action of the big screen to the small screen behind your computer than the company responsible for some of the most outstanding software releases of the past five years.

So don't hang about, get your entry in, and go back to the future now...

**ACE and MIRRORSOFT bring you a once in a lifetime chance to live out your dreams in Hollywood, and on the set of *Back to the Future II***



## THE QUESTIONS

Just answer these two questions correctly, and send your completed card (mounted on the cover of this issue) back to us. If you also want the chance to win £500 of spending money you should attach to your card the bonus coupon printed in next month's issue of ACE. The coupon can also be found on the cover of the manual for Mirrorsoft's *Back to the Future II* game.

1. Who produces the *Back to the Future II* game?
2. Name one other film that has starred Michael J. Fox.

## MOVIE MAGIC

Those software sensations Mirrorsoft have four sure-hit movie tie-ins destined for release over the coming months. Here is a quick run-down for you grateful gamers to drool over...

## THE PRIZE

The winner of the first correct entry out of the hat will win a return flight to Los Angeles, and Hotel accommodation for a week (including breakfast). During the holiday you will also take a trip to Universal studios (home of such epics as *Jaws* and, more recently, *Born on the Fourth of July*). The universal trip is completed with a visit to the set of the hit Michael J. Fox movie, *Back to the Future II*.

If the winning entry has a bonus coupon attached (see below) then the winner will also take £500 of spending money with them.



# Hollywood!



## Back to the Future II

In the first *Back to the Future* film Marty has managed to ensure he gets born, by getting his father and mother together. In the sequel he must travel forward to the year 2015 to influence the lives of his children. While in the future he discovers a racing almanac and is tempted to use it to make himself rich. Fortunately Doc talks him out of the plan, but their arch enemy Biff is less scrupulous about using the almanac.

In the game you must guide Marty and Doc through five action packed missions in a last ditch attempt to stop Biff causing disaster in the present. Each mission is a superb arcade challenge that will keep you coming back for more.



## Back to the Future III

Marty and Doc are back again. This

time the DeLorean time machine transports them back in time the Wild West in the 1800's. There Doc and Marty find there are many more adventures awaiting them. The computer game is being programmed by first class development team Probe, and is due for release at Christmas.

# PREDATOR 2

## Predator II

Schwarzenegger is back, and this time he is fighting for more than his life. In *Predator* old Arnie and his platoon get caught in the jungle by something very nasty from outer space. Fortunately the Iron man got out alive. But in the sequel there are even nastier things in store...

## THE RULES

1. The closing date of the competition is Friday 24th August 1990.
2. The winning entry must have the bonus coupon attached to be eligible for the bonus prize of £500 spending money.
3. The holiday must be taken in October/November 1990 or from January to March 1991.
4. If the winner is under 18, then the accompanying person must be aged 18 or over.
5. The judges decision is final, and no correspondence will be entered into.



## Flight of the Intruder

This game is based on Steven Coonts best-selling novel of the same name, now made into a major movie. The game deals with the US Navy's bombing campaign in North Vietnam in the early 1970's. There is a choice of two planes to fly: the Intruder, or the Phantom. The film is a harrowing story of two pilots flying missions in Vietnam and the conflict between their commitment to their friendship and their country.

**Your dates:**

13th-16th  
September

**Your venue:**

Earls  
Court

**Your show!**



**Continuing the tradition  
but dedicated to leisure.**

Sponsored by C&VG, SINCLAIR USER, CU, ACE and THE ONE.

Contact: Sally Buller at EMAP International Exhibitions: 01-251 6222 ext: 2406  
or Gary Williams ext 2518

Fas  
he  
in  
iss

N  
tech  
out g  
and

● We  
read  
face  
desig  
myste

Hey  
at A  
Mir  
get  
pro  
opp  
out  
eno  
and  
the  
A  
plan  
that  
also  
E  
subs  
appl  
enou  
appl  
12th



Tetris running on the Macintosh. Find out more about this Russian success story in next month's special Glasnost issue

# WE'RE CELEBRATING!

Fasten your seat belts: here's what's coming up in next month's ACE issue...

**N**ext month sees the third anniversary issue of your favourite entertainment technology magazine, and we're handing out goodies galore. Yup...we're celebrating, and y'all are invited to join in the fun.

● **We're celebrating** – with a competition for all readers who think they've really got the guts to face the unknown. Lord British, the fiendish designer of the *Ultima* series, has constructed a mysterious mansion atop a hill in Austin, Texas.

## ACE CONFERENCES

Hey! Don't miss out! The next ACE Conference – at Activision – still has some vacancies (the Mirrorsoft is now full). If you come along, you'll get a fascinating glimpse into the business of producing games, find out about career opportunities, and get the opportunity to try out some of the latest software. And if that isn't enough, you also get loaded up with freebies and can indulge yourself with a free lunch into the bargain.

Activision are based in Reading and are busy planning a great event for you. And don't forget that you don't just get to see the games – you also get your photograph in the magazine.

Entry to the conferences is free for subscribers, and a nominal £5 for other applicants. The software you get should be enough on its own to make it worth it. Get your application in NOW – the conference is on July 12th – so you'll have to be quick!

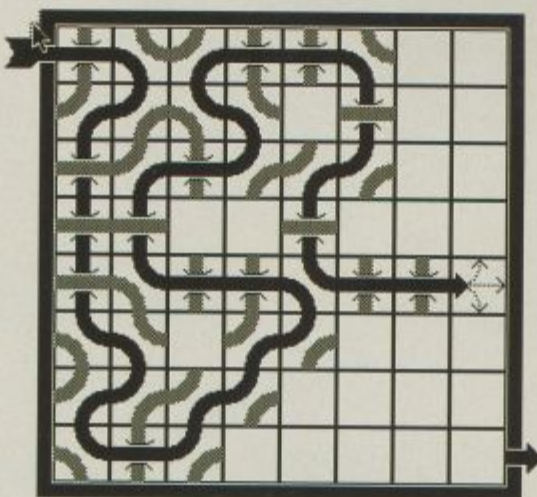

Remember Brian Crawford? He was the programmer we stayed with in Marin County, California and wrote about in our American issue (no 31). At that time we reported that Brian would be sending us his new game – which we found simple but infuriatingly addictive in Pipemania fashion – for review. The finished copy has finally plonked through the letter box and we'll be covering it next month, together with details of how lucky Mac owners can order a Shareware copy and some tips from Brian on how to set about writing your own game – without sacrificing every minute of your life to do so. See 'Brian's Guide to Laxy Programming' in the next issue...

Every year, he expends a considerable portion of his enormous wealth in creating the sort of Halloween party most people just dream of.

Lord British has been a long-standing ACE-friend, ever since we got so hooked on *Ultima V*, and he's issued a personal invitation to an ACE reader to attend the Lord British Halloween Party. You can find out more about it in next month's issue...

## CES SHOW HOTS UP!

And not the American CES either, but our very own Computer Entertainment Show in Earls Court in September. It runs from the 13th to the 16th of September – the 13th and 14th are trade-only days and the show opens to the public for the 15th and 16th.

Next month you'll be able to get further details about the ACE stand, which boasts a unique Living Room of the Future exhibit. Full details of the show will be published over the next couple of months in ACE.

Some good news already, however. We've been to California to meet with Subjective Technologies – the producers of the IMME (Interactive Multi Media Engine) and they have now definitely agreed to show the IMME in action.

We also hope to have the Commodore CD-TV in action, and possibly a prototype of the extraordinary Sony hand-held CD-I unit. Experts will be on hand to answer all your questions and we'll be running special competitions on each day with some fabulous prizes. Don't miss it!

● **We're celebrating** – giving you the first chance any British gamester has had to penetrate behind the Iron Curtain with our Russian Special Issue. Set off to the birth-place of Tetris and let ACE be your guide...

● **We're celebrating** – with more computer, console, and CD coverage than ever before. Plus a chance to add £500 spending money if you win the Hollywood competition in this issue.

**Don't miss it! Out on the shelves on Thursday August 3rd. Or why not take out a subscription? See page 96 for details.**

Radar can't detect it –

**F-19**

STEALTH FIGHTER

but it's coming..



The Biggest,  
Fastest and Smoothest Flight Simulation ever seen.

You're flying on high octane adrenalin

# F19

## STEALTH FIGHTER

Forget about other flights of fancy – This is the Real World.



*Imagine Falcon – imagine a few hundred square miles of fantasy.*

*Imagine F29 – imagine a few thousand miles of fantasy.*

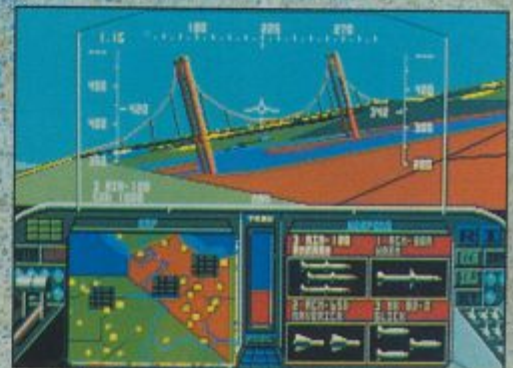

Fly F19 – fly over 409,600 square miles of reality. Fly fast. Fly the real thing.

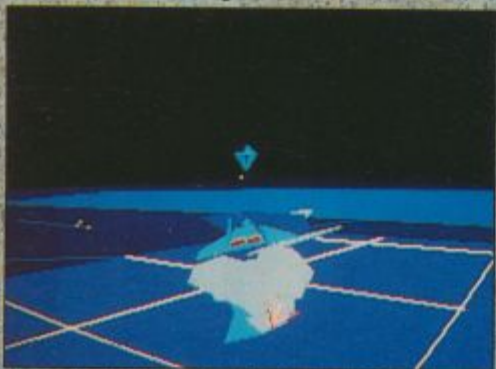

*Over 3,300 missions possible.*

*Cold, limited or conventional war.*

*Four grades of opponent.*

*Four real-world scenarios.*



*All the action you can handle – and always a new challenge waiting.*

*Graphical detail and depth of gameplay are claims made by others – here they are reality.*



**FLY F19 SOON ON  
YOUR ATARI ST AND  
COMMODORE  
AMIGA.**

**MICRO PROSE**



IBM Screen shots shown. Actual screens may vary.



# Sim Earth

## The Gaia Principle

The world is your oyster!  
 Have you got what it takes to  
 create and manage a whole  
 world? And what on earth  
 is the Gaia principle?  
 ACE reveals all in this  
 exclusive playtest of Maxis'  
 Sim Earth...

**S**im City, the City Simulator by Maxis, was one of the most original titles to hit home computers last year. The other main contender was, of course, *Populous* by Electronic Arts. *Sim City* allowed the player to create, evolve and maintain their own bespoke urban environment, it broke through a lot of traditional computer gaming boundaries and more than a few of the so-called hard and fast design rules. This hasn't stopped it becoming a global phenomena in its own right, being a major hit in all territories – Europe, USA and Japan.

So, what do you do after publishing the ultimate City Simulation? Well, by the looks of Maxis's next release – *Sim Earth* – you go on to publish the ultimate Planet Simulator. Yes, just when you closet megalomaniacs have got tired of lording it over a paltry few million sims, very soon you'll have the opportunity to shape the destiny of whole planets! Sounds interesting?

Presently in the final stages of development on the Macintosh, *Sim Earth* will be available on more common 16bit formats – and the CDTV – in the fullness of time, but ACE has acquired an exclusive look at the product right now – and it's looking good!

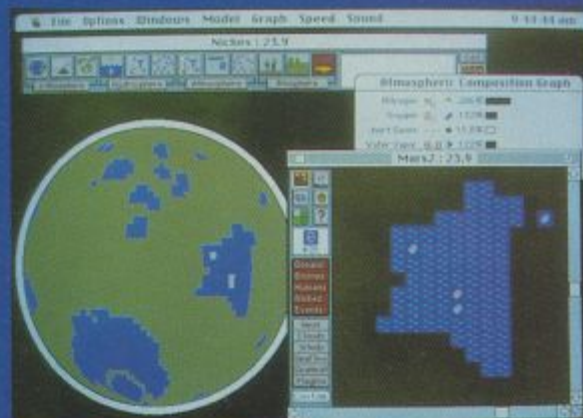

If there life on Mars? Only using Sim Earth!



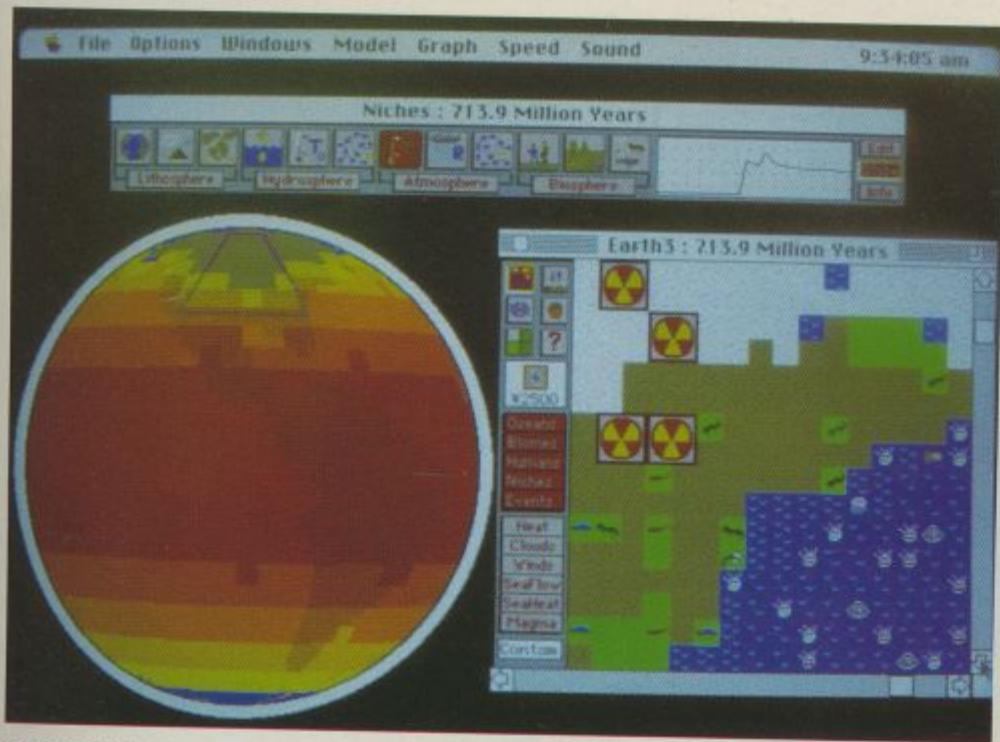

**CARICATURE**

Ambitious in the first word that springs to mind. Modestly Maxis describe *Sim Earth* as a "rough caricature" as far as simulating an Earth-like environment. True enough, considering that even using the largest million pound super computers, a fully accurate model of the Earth's atmosphere alone has yet to be developed.

What *Sim Earth* will let you do on your 'primitive' system costing only a few hundred notes, is take this planet from the very moment that a crust forms on the molten lava of its surface billions of years ago – and play around with just about every major environmental variable right through to past the present day. Even the most impartial observer would have to admit, it's an impressive achievement.

In actual fact, there are several different scenarios you can start off with at the beginning of *Sim Earth*. Taking on the role of Planetary Regulatory Manager, you can start fooling around with a planet at three points in its history: at the Archean Era just when the crust is forming (4.5 Billion years ago), the Cambrian Era when multi-cellular life had just started forming (550 million years ago) or take on the Technological Era (starting around 40 years ago).

Selecting a starting Era, you can play Earth as it is, or take a randomly generated planet in hand. The point of having these three stages is to have manageable time-scales appropriate for the major planet forming events that were taking place during these times.

From the Archean Era on to the Cambrian is the period of Geological time. Here the major factors affecting the development of the planet are Continental Drift, atmospheric composition, extra terrestrial collisions and the evolution and action of single celled life forms. Hence, the planet changes very slowly – therefore the time allowed for each simulation 'cycle' is 10 million years.

On to the Cambrian and 'Evolutionary' time. Here your major goal is to nurture life and intelligence up to the development of civilisation – be it human, mam-

This planet is hot... just like Sim Earth

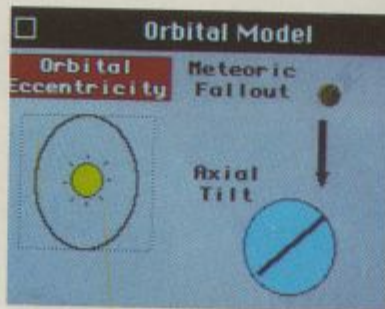

Altering the Model, by playing around with the basic constraints of the simulation. Superb 'what-if' scenarios can be thought up. Like what if the Earth has the axial tilt of Neptune? What if the Sun was hotter? Let your imagination run riot!

*"If you plan for a year, plant rice. If you plan for ten years, plant trees. If you plan for 100 years, educate your children."*

Ancient Chinese Proverb

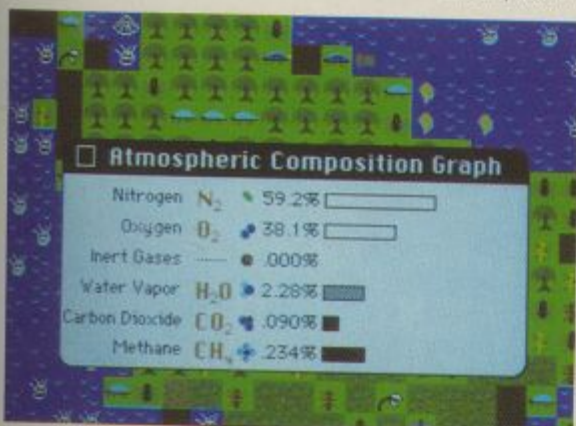

Information boxes give you detailed data on your progress

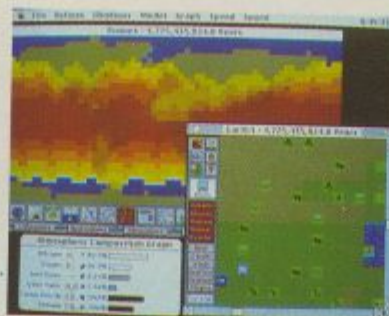

Zooming in on the action

**THE GAIA PRINCIPLE**

A few years ago, a scientist named James Lovelock proposed an idea that you could think of the whole planet as acting as a single organism, rather than being a collection of unrelated species, niches and ecosystems. If you're interested in the detail of the idea, you can go and read his book, but the upshot is that in this view of the global ecology, there are self-regulating systems that tend to absorb environmental shocks and attempt to bring the system back in equilibrium.

This is not as way out and wacky as it sounds, particularly if you treat the theory as a mind set to use on a conceptual view of the world, rather than taking it literally. Living organisms are packed full of self-regulating feedback systems – it's not that wild to extrapolate this to collections of organisms.

The model within *Sim Earth* encompasses the Gaia (Greek Goddess of the Earth) principle – indeed one of the initial scenarios is Lovelock's simplified example of a global interacting ecology, 'Daisyworld', on which the only two species are black and white daisies, black being sensitive to heat, white being sensitive to cold. Those with a smattering of ecology will understand what happens from there on in – others will have to buy *Sim Earth* and find out! And try playing *Sim Earth* with the Gaia principle turned off – that's when it really starts getting difficult. Maybe Lovelock is on the right track after all?

malian or sentient molluscs. The major factors you have to watch are Climate, Life Forms (Biomes) and their Evolution. The cycle time speeds up to 500 million years per turn.

Moving on, you get to Civilisation time from 10000 years ago to 100 years ago – where the problem of sentient expansion has to be dealt with in addition to other factors. So the cycle time is now slowed down even further to 10 years per turn. Finally, when you start dealing with Technological Time, it's one year per turn. Things happen fast in this mode.

**RULES AND TOOLS**

You can think of the simulation consisting of Rules – the logic of the program itself that determines cause and effect and Tools, variable factors that you can alter to attempt to create the kind of world you want. And naturally, being the kind of simulation it is, if you really want - you can even change the most basic of rules, when in Experimental Mode. Like turning the Sun off. Not terribly good for the planet, but spectacular in result!

After selecting the style of game you want to play – and as well as Earth-like planet management, there are the Mars and Venus terraforming challenges – a new world is generated and displayed in a box across the screen in Mercator map style format. This is the World Display Area (WDA). Along the bottom of the WDA is a series of boxes that, if selected, will overlay specific information on top of the map.

This display gives you a whole overview of what is happening down there, and you need to make frequent use of it as your eyes and ears. The information you can call falls into four categories: Lithosphere, Hydrosphere, Atmosphere and Biosphere. Respectively, the boxes will show you Altitude, Current Major Events, Continental Drift Vectors, Raise or Lower the Oceans (to inspect the sea bottom), Ocean Temperature, Ocean Currents, Air Temperature, Rainfall, Air Currents, Human Population Density, Biome Distribution and Animal Diversity. All this is overlaid in easily digestible form, while accompanying information is displayed on a small graph to the right of the boxes.



Choose your game type

The world may also be displayed as a globe – but although this is very appealing aesthetically, most Planetary Managers prefer to see the whole of the planet at once. You now have an idea of what is going on, down on your planet – for a close up, you select the View Window, which will display a close up of part of the planet. It's from here that you do all the major interference.

On the bottom right of this Window is a strip of buttons that regulate what is displayed within the Window (Oceans, life forms, etc) and what information, if any you want overlaid on top, such as temperature.

At the top right are the six controls that you'll use most within the game to make your mark on the planet. Starting with the bottom left of the six, clicking on this brings up a sub-menu that lets you select and place a Niche onto the surface of the planet – a habitat for an organism or species. Many will evolve naturally, but maybe not to your liking.

Once you've set up a niche, you'll want to pop in some life, maybe. Clicking on the top left box gives the sub-menu for selecting various forms of Sea Life,



View Window Controls



Landscape gardening on a global scale! What would Spain be like as a swamp?



It's life Jim, but not as we know it! Prokaryote to Nanotech – back to biomes, back to reality

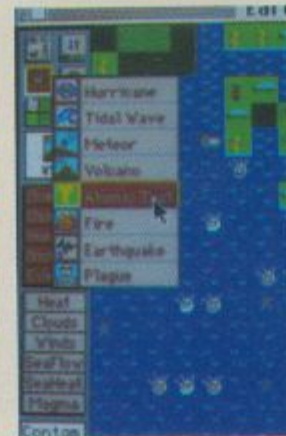

Let's plague Portugal, atomic test Argentina and tidal wave Tokyo...

## THE EARTH AT YOUR POINTER CLICK

The World Display Area is controlled via the Display Icons. Click on a particular icon and specific information will be overlaid onto the screen. The icons are divided into four specific groupings: Lithosphere, Hydrosphere, Atmosphere and Biosphere



LITHOSPHERE GROUP	HYDROSPHERE GROUP	ATMOSPHERE GROUP	BIOSPHERE GROUP
<p><b>GIVES INFORMATION ON THE SOLID PART OF THE EARTH</b></p> <p><b>Terrain Map:</b> Shows oceans and altitude across the planet</p> <p><b>Event Map:</b> Indicates local events such as earthquakes or meteor strikes</p> <p><b>Drift Vectors:</b> Shows the direction and speed of continental drift</p>	<p><b>GIVES INFORMATION ON THE OCEAN</b></p> <p><b>Raise/Lower Oceans:</b> Toggles the Ocean display on/off so you can see what's going on underneath. This can be used in combination with other maps</p> <p><b>Ocean Temperature:</b> Displays average water temperature. Usually corresponds to the air temp, but changes much more slowly</p> <p><b>Ocean Currents:</b> Displays surface currents of the Oceans, which shift vast quantities of heat around the planet</p>	<p><b>DISPLAYS INFO ON THE ATMOSPHERE AND CLIMATE</b></p> <p><b>Air Temperature:</b> Displays average annual air temperature, coming primarily from the Sun and then from the Ocean</p> <p><b>Rainfall:</b> Displays average yearly rainfall, the heaviest usually being concentrated around the equator</p> <p><b>Air Currents:</b> Displays average air currents around the globe</p>	<p><b>GIVES INFORMATION ABOUT LIFE ON THE PLANET</b></p> <p><b>Human Population Density:</b> Shows the distribution of humans on the planet – more advanced the civilization, the darker the display</p> <p><b>Biome Distribution:</b> Shows distribution of major ecosystems</p> <p><b>Animal Diversity:</b> Darker areas show a higher number of species per acre</p>



The world really is your oyster!

Land Life or Civilisations. If conditions are right on the planet, many of these will evolve naturally as well, but perhaps not to your grand design.

Finally on the left is an event generator. Available to you are Hurricanes, Meteors, Tidal Waves, Volcanoes, Atomic Tests, Fire, Earthquake and Plague. Four Horsemen of the Apocalypse eat your heart out. All sorts of fantasies can be lived out using these, especially when selecting Modern Day Earth. Nuke Argentina? No worries. Sure, this can be a bit sick... but you do get to realise that it only takes a few nukes to generate a serious nuclear winter. Not exactly the best way to promote life on earth!

Ever wanted to know what happens when you fill in the Atlantic? Try it with the raise/lower option on the upper right. Going down that column, the Hand icon lets you move Life Forms about (good for separating warring tribes), and the Question Mark lets you click on any area for a detailed report on its contents.

Fiddling about with the planet does cost, however. You have an overall Planetary Interference Limit that varies according to the difficulty level you choose – but it works like the budget did in *Sim City*. Big things – like trying to plant a technological life form in the Precambrian Era – cost a lot and won't last long in any case. Smoothing out the rough edges of an ecosystem is more sensible and more likely to produce a result.

That's the simple overview of the controls, then, but like as in *Sim City*, the real joy of *Sim Earth* is getting down, booting it up and getting to grips with exploring the complexity of the model. Just taking the Earth from Geological age to the present day – watching the continents form and evolution taking place before your very eyes – is quite remarkable. Then you start thinking – well, what if...

The confessed aim of the game is to nurture a technological species to the stage where they can get the hell off the planet and 'seed' another – in fact you find your own pleasure and goals in the things as soon as you've got to grips with the controls.

Ocean has signed up the European rights to *Sim Earth*, persuading Maxis to develop a version for the CDTV – due early next year.

Fascinating, intriguing – gulp dare we use that word, educational? No, let's try 'informative' instead. *Sim Earth* is shaping up to be a more than worthy successor to *Sim City*, and in the current 'Green and Globally Aware' climate is certain to find a audience way beyond that of most games.

### RELEASE BOX

ATARI ST	£TBAck	EARLY '91
AMIGA	£TBAck	EARLY '91
PC	£TBAck	LATE '90
MAC	£TBAck	IMMINENT
CDTV	£TBAcd	EARLY '91

Other versions under consideration.

### WORRIED ABOUT THE WORLD?

World Resources – 1990-91 Guide to the Global Environment is "the most comprehensive report on the world's critical environmental and natural resource problems". Its published by Oxford University Press for \$17.95 (paper) or \$29.95 (cloth).

# HARLEY-DAVIDSON: THE ROAD TO STURGIS

It's Harley heaven as you straddle your 1340c.c. Hog and scream through the box. You're off to the biggest bikers rally yet in Sturgis, South Dakota - if you can make it in time.

Speeding tickets, blow outs and plain dumb decisions could leave you eating dirt instead of burning rubber. There are five games with varying difficulty levels. The graphics are great and the sounds will outrage even the friendliest neighbour.

So climb on, max out and cruise the open road for the ride of your life.

Available for Amiga, Atari ST, IBM, Tandy and compatibles.

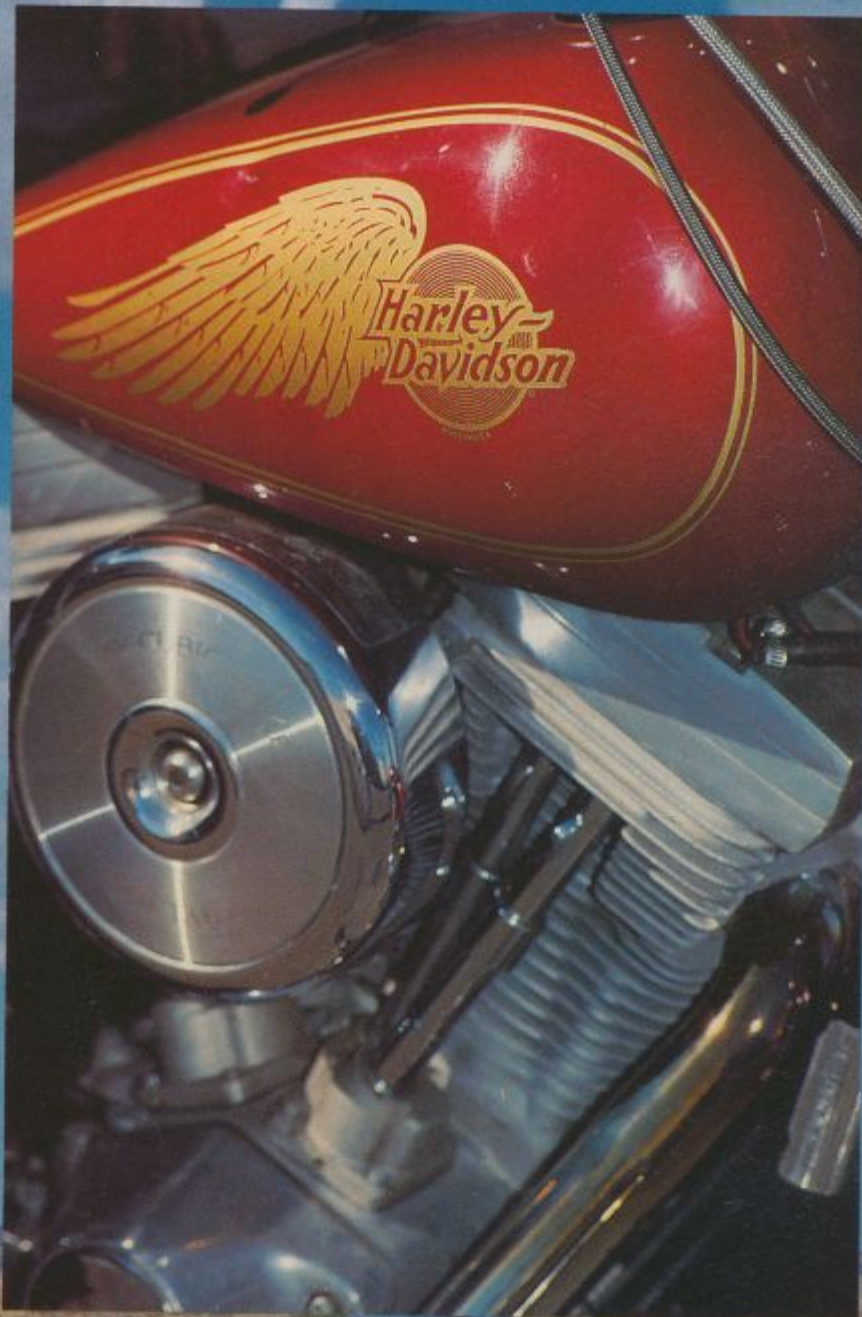

# M I N D S C A P E

For further information on Mindscape products and your local Dealer, contact:  
Mindscape International Limited, PO Box 1019, Lewes, East Sussex BN8 4DW. Tel. (044 486) 545/547.

COMING SOON...

# BACK TO THE FUTURE II

PART II



© 1990 MIRRORSOFT LTD © 1989 UCS & Amblin

IMAGE WORKS, Irwin House, 118 Southwark Street, London SE1 0SW. Tel: 071-928 1454 SCREENSHOTS:

Atari ST

4 & 5 Courtesy of MCA

**THE**  
Screen  
That's  
around  
maga  
First  
(inclu  
The  
advan  
Fin  
review  
At  
tomor

**AN**  
Que  
grab  
Anst  
the A

Each re  
special  
imple  
ratings

**GRAPH**  
All asp  
each n

**AUDI**  
The m  
is poss  
PC if th

**IQ FA**  
The Br  
gener  
human  
expect

**FUN I**  
Basica  
Arkan  
power  
score  
satisf  
intellig

**ACE**  
To get  
very a  
gener

90  
rese  
80  
lon  
cate  
70

THRE  
to do  
game  
Game

# Screenest

## THE DEFINITIVE GUIDE TO GAMES

Screenest is designed to give you a solid foundation for the games reviews of tomorrow. That's why we divide the section into three. We review and preview the latest games from around the globe... British to French, Japanese to German, American to Russian. No other magazine offers you as comprehensive a guide to games as ACE!

First, you get reviews of traditional **COMPUTER** games running on ALL major formats (including 8-bit and minority machines).

Then there's our **CONSOLE** section, bringing you up-to-date coverage of the most advanced console entertainment.

Finally, ACE is the *world's first magazine* to introduce a regular section for the exclusive review of **CD** entertainment – the storage medium and hardware format of the future.

At last – computers, consoles, and CDs, for the complete coverage of games today – and tomorrow.

## ACE Rated!

**Question:** Is this game really going to grab me? And for how long?

**Answer:** the PIC curve – the heart of the ACE Rating System.

Each review carries a PIC Curve (see Pic Power panel) and special 'Version Boxes' that give you details of the game's implementation on a specific machine. These boxes include ratings for...

### GRAPHICS

All aspects of the game's graphics – with the limitations of each machine taken into account.

### AUDIO

The music and sound effects are rated here. A high rating is possible on even limited machines like the Spectrum and PC if the computer's shortcomings are cleverly sidestepped.

### IQ FACTOR

The Brain Strain rating. Note that ACE readers are generally reckoned to be more intelligent than other human beings, so the ratings may be lower than you expect...

### FUN FACTOR

Basically a measure of mindless addictiveness. Games like *Arkanoid* and *Flying Shark* require virtually zero brain power but are still remarkably addictive. Most coin-ops score well here because they are designed for instant satisfaction. Games don't have to be either fun or intelligent – they can be both.

### ACE RATING

To get a really high rating a game will not only have to be very addictive but stand the test of time as well. Here's a general guide to what the ratings mean:

**900+** A classic game, recommended without reservation.

**800-899** A superb game, but perhaps lacking the long-term depth to last into the month and year categories.

**700-799** Still highly recommended, but probably has

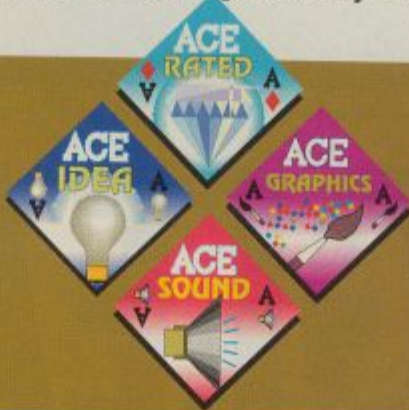

### THE ACE AWARDS

ACE always rewards excellence. Our seals of approval for outstanding software performance. If a game really breaks the boundaries in sound, graphics, or originality you'll see the appropriate ACE Award flash on the review. Unless it's truly dire – in which case it'll get the ACE Turkey award. Software houses: you have been warned!

a couple of aspects to the gameplay that take the edge off it.

**600-699** The 'fair' zone, where it tends to be very good 'if you like that sort of thing'.

**500-599** This still has good things going for it, but the game clearly has some noticeable problems.

**400-499** Problems with gameplay and programming make this an inferior game.

**300-399** Not only is the gameplay bad but the design was probably flawed in the first place.

**200-299** Things are getting really serious now...

**100-199** ZX81 games running on an Amiga.

**Under 100** Nothing has ever achieved this appalling level of rating. If anything ever does, it wouldn't even be worth having it for free.

### VERSION BOXES

This covers version-specific information on graphics, audio, loading problems etc. If there's no box for your machine but a version is planned, it'll be covered as an update in a later issue.

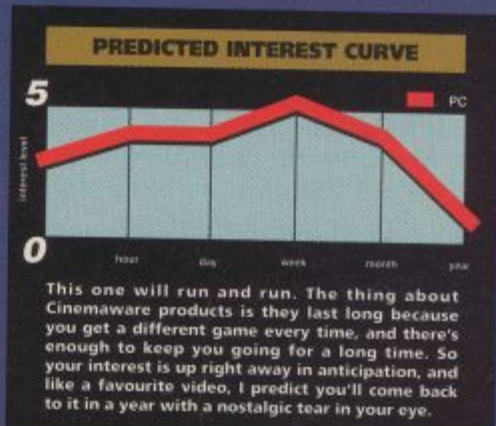

This one will run and run. The thing about Cinemaware products is they last long because you get a different game every time, and there's enough to keep you going for a long time. So your interest is up right away in anticipation, and like a favourite video, I predict you'll come back to it in a year with a nostalgic tear in your eye.

## PIC POWER!

The PIC – Predicted Interest Curve – is the most sophisticated reviewing tool around.

We on ACE know you don't just play a game – you experience it. The Predicted Interest Curve is the only review system that takes this all-important factor into account.

The curve is divided into six sections, indicating the player's adrenalin level after one minute, one hour, one day, one week, one month, and one year. But this tells you an awful lot more than just what your interest level will be at any given time (although that's obviously important in itself)...

For example, a high one minute rating means that the game must look fantastic and get you all excited from the word go. That means it's probably a good game to show off to the neighbours – who probably aren't going to pay attention for much more than a minute anyway.

The minute, hour, and day ratings can tell you a lot too. If there's a dip here, followed by a rise, you've got a game that may take a bit of getting into – not recommended if you like to get down to something quick and easy. Alternatively, the graphics may put you off for a while until the gameplay starts to grip. Check out the PIC comment for more details.

Finally, you've got the month and year ratings. The better a game holds up here the more deserving it is of your hard earned cash.

## THE ACE PROMISE

1. Unlike many magazines, ACE ONLY reviews finished games. If it's reviewed here, it's what you'll get in the shops. If there's any exception to this rule, the page will clearly be marked PREVIEW and the game is not rated. We won't let you down by reviewing half finished versions and demos.

2. Every game has been extensively tested. If we come across bugs or other deficiencies, we check immediately with the company concerned. Then we give you the whole story. Whenever possible, we'll give you more than just the review – analysis, comparison, and technical information is all included wherever possible.

3. All ratings are carefully calculated. You can rely on them to make your buying decisions.



THREE NINTENDO GAMEBOYS are up for grabs! All you have to do is read the preview of Mindscape's new role-playing game by Tony Monty Mole' Crowther, enter our Name the Game competition, and wait to win. Full details on page 45.



The classic Paperboy rides onto the Sega Master System – check out the hot four page console section for reviews of Sega Megadrive Tetris, PC Engine Powerdrift, Nintendo Gameboy Batman, Sega Master Ultima IV, plus much more...



Rise of the Dragon – one of the stunning micro movies previewed in this issue. Sierra On-Line and Dynamix have teamed up to produce Enteractive Entertainment titles for the PC, Amiga, ST, Macintosh and various CD-ROM machines.

"Groundbreaking 3D graphics. Spatially realistic stereo sound. A new cinematic game experience," that's what the guys at Origin and UK distributor Mindscape are promising with their new game, *Wingleader*. And they're not joking either. *Wingleader* was the hottest game on display at the recent Summer Consumer Electronics Show in Chicago.

Origin already has thousands of role-playing fans thanks to its highly successful series of *Ultima* fantasy games. Now the leading Texas-based software developer has set its sights on the shoot'em-up player looking for something special and a little more sophisticated. *Wingleader* is the result. It combines three dimensional space shoot'em-up action with the audio-visual feel of sci-fi movies like *Battlestar Galactica*, *Star Wars* and *The Last Starfighter*.

Sadly, the screen-shots shown here completely fail to convey the cinematic experience of the game. "*Wingleader* has to be seen and heard to be believed."



Navigating a dense asteroid field

# WINGLEADER

## LEADING THE WING

"In the 27th century, personkind is locked in a deadly war with the Kilrathi, a vicious, militaristic alien race. Leading the fight are the daring pilots of the Terran Confederation, meeting Kilrathi warships in their fast, well-armed one-person starfighters. With faithful wingpeople flying by their side, the fearless *Wingleader* battles with Kilrathi aces in heated deepspace dogfights for the future of humanity." You play that *Wingleader*.

"In the game you lead daring missions against Kilrathi fighters and warships, transport ships and space stations. You're not alone out in space. On every mission, you have one of eight trusty wingpeople at your side. Each with their own personality and flying style, individual quirks and priorities. Your wingperson is an invaluable ally, guided by your commands and the mission objectives."

"During the campaign you fly four different Terran Confederation starfighters. The Hornet,



Cinematic launch and docking sequences hurl you into the action

Scimitar, Rapier and Raptor each have their own unique armament and flight characteristics. You face a similar assortment of starfighters on the Kilrathi side - quick, under-armoured light fighters, reliable medium fighters, and heavy fighters carrying a wide array of missiles and guns."

"As you close with the enemy, you can open up with intelligent missiles - Image-Recognition and Friend-or-Foe - capable of independently tracking a target. Or you could switch to your guns - lasers, neutron cannon or mass-driver cannon. If you can manoeuvre behind your opponent, lock a Heat-Seeking missile on their exhaust and watch it chase them down. And for the killing blow, you might choose a Dead-Fire missile, which lacks tracking sensors, but packs the most powerful warhead in your arsenal."

Of course the Kalrathi pilots aren't going to sit still while you

**ORIGIN/MINDSCAPE hit hyperspace with the world's first cinematic 3D space combat simulator**

PC	\$59.95dk	AUTUMN
AMIGA	£TBAck	EARLY '91
ATARI ST	£TBAck	EARLY '91
No other versions planned.		

engage them in combat. "The enemy starfighters are controlled by advanced artificial intelligence. You see them perform incredible acrobatic manoeuvres - barrel rolls, Immelmann turns, split Y's - as they close in for the kill."

"But there are more than just starfighters in this game. You attack and defend larger vessels ranging from small corvettes and transports to huge dreadnoughts and starbases. It's especially important that you defend your own carrier, the Tiger's Claw, against Kilrathi warships. If the Claw blows, you'll be stuck in deep space with only a few hours of air and no place to go."

## EXPERIENCE THE CINEMATIC

"Origin has incorporated several cinematic and interactive animated sequences into *Wingleader*, which set the stage and frame the dogfight action. In these sequences, you meet the crew of the Tiger's Claw, as well as visit the hangars, launch tubes, and landing bays of the huge starship."

"Before each mission, you attend a briefing, where your commander outlines your mission



The Claw has a resident bartender and amateur psychologist

CREATING COMPUTER CELLULOID

*Wingleader's* creator is Chris Roberts, the author of *Match Day*, *Times of Lore* and *Bad Blood*. "When Roberts set out to create *Wingleader*, his goal was to design the most exciting, realistic three-dimensional space combat simulator ever."

"Roberts was unsatisfied with the 3D colour-filled polygon graphics systems used by existing simulators. He wanted greater detail and realism. The obvious alternative was bit-mapped graphics, but data storage is a great problem for this type of graphics system. For while a polygon-based system only stores one version of an object in memory, a bit-mapped system requires a separate image for every possible view of that object. To address this problem Roberts wrote a unique system for moving bit-mapped objects through 3D space."

"Each ship was designed on paper and then modelled as a 3D shape on a computer. Then dozens of ray-traced views of this 3D shape were generated and saved as bit-mapped images. Finally, computer artists touched up the ray-traced images by hand, refining them and adding detail. The resulting bit-mapped starships are far more realistic than any polygon shape could be, taking full advantage of the highlights, shading, curved surfaces, insignia and surface detail possible in bit-mapped 256-colour VGA graphics."

"Now that he had bit-mapped ships that could be viewed from

any angle, Roberts began work on the driver that would move them about in space. A vector movement system plots and moves objects in space relative to the player's ship and point of view. Scaling and rotation routines reorient the graphic image of the ship."

"Together, these functions allow the programmer to place the point of view, or camera, at any point in the universe, and aim it in any direction. The computer, which has already plotted the position and vector (direction and speed) of all objects, then determines which objects are visible, selects the appropriate view of each, then scales and rotates that view to reflect the object's distance from the camera and its vector."

"Incidentally, this highly-flexible system allows *Wingleader* to offer a wide variety of camera angles, including front, rear, right and left, 'chase-plane', tactical - which chooses an angle showing the player's ship and their opponents regardless of their relative positions, missile - which follows a missile to its target, and cinematic - which presents dramatic third-person views of the ship zooming past the camera or locked in a tight dogfight."

"To create realistic animated characters, Roberts emulated the cinematic technique of rotoscoping, staging the character's actions with human actors and shooting them on high-quality video. The video images were then turned over to Origin's computer artists, who defined and enhanced each animation frame for inclusion in the game. And like the starships in outer space, these cinematic sequences are fully rendered in 256-colour VGA for the richest possible colour."



*Wingleader* is the first computer game to bring you the audio-visual quality of movies like *Star Wars*, *Battlestar Galactica* and *The Last Starfighter*

objective on a large vid screen. Every character is fully animated, with both long, full-body shots and close-ups. Then you see the pilots scramble, charging down the corridor to their starfighters. The launch sequence shows your starfighter hurled into space at full velocity by a magnetic rail."

"Out in space, animated sequences take advantage of *Wingleader's* unique 3D technology to offer cinematic transitions as well as dramatisations of critical events. If your flight plan includes a lot of empty space to cover, simply engage the autopilot - the scene will cut to a cinematic view of your ship and that of your wing-person, roaring past the camera. When you're at your destination the computer returns control of the ship to you."

"When your ship's taken a fatal hit, you see sparks spout from your control panel. Then the camera cuts to an exterior view, and you see your crippled fighter tumbling out of control. The camera cuts back inside the ship, with a shot of you covering your face against the explosion of your ship."

"To emphasise the cinematic feel of *Wingleader*, Origin used George Alistar Sanger - a professional composer and arranger better known as The Fat Man - to assemble a complete, movie-style score for the game. In addition to the *Wingleader* theme tune, various separate musical

passages were composed to reflect specific events and conditions in the game. Based on the flow of the battle, the program intelligently selects and plays appropriate background music - for example, the tense chaotic battle theme that accompanies dogfights increases in tempo and complexity as the pace of the action rises. A crescendo marks the death of an ally, and a dirge follows your death."

"Along with the cinematic score, *Wingleader* also incorporates a wide variety of carefully selected and crafted sound effects for the starships, weapons and explosions. The game also supports full stereo sound effects for players with PC soundboards. Explosions boom from one speaker or the other, depending upon their point of Origin, and the engine noise of enemy starfighters pans from one speaker to the other as they buzz past your ship."

PREPARE FOR LAUNCH

*Wingleader* will be released on the PC in early autumn. The game comes on seven 5.25" disks or four 3.5" disks. It's compatible with Tandy, EGA, VGA and MCGA graphics cards and AdLib, Soundblaster, Roland MT-32, LAPC-1 and Tandy 3-Voice soundboards. Amiga and ST versions are also planned for later in the year. Playing *Wingleader* is like playing a film.

● Rik Haynes



The dramatic final seconds of your death sequence

# BAD BLOOD

**ORIGIN/MINDSCAPE get friendly with the muties in this post-holocaust arcade adventure**

**H**ey there, if the olduns is right there's some bigbig trubbs comin' for us muties. Our himukk gave us the chat last night. Way he shivs it, the humes are hacking on slaggin' us proper. Buzz is that those hume tuffs have stockpiled their nades 'n' oozees, plannin' to make ev'ry taint they see into a stiff. No way we're gonna tackle 'em - too damn dicey. We need somethin' to boost us pretty fast. Looks like you just got yourself a bigbig chunk of the action.



Our mutant hero takes to the water - not the most friendly of environments with the likes of the Legtter around



Zero Town is all that is left of an ancient city. Highly radioactive, but unfortunately an essential stopping off place on your quest

OK that's enough indecipherable chat. Better get used to it if you plan on completing *Bad Blood* though. The game is set in the future in a world ravaged by Nuclear War. The radiation resulting from the war has given rise to mutations amongst the wildlife and the human species. Over the years the pure humans have come to despise the muties and are now preparing to wipe them out completely. You have been

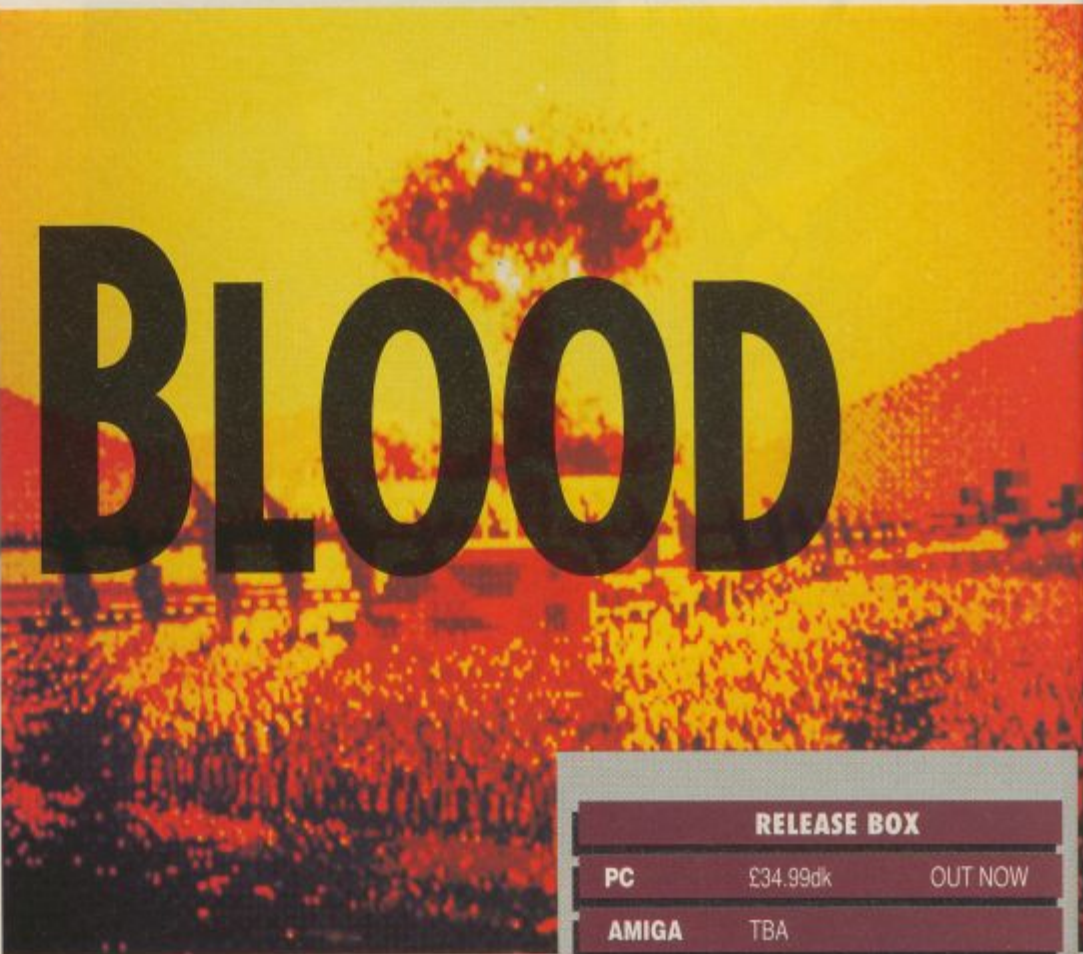

chosen by the other mutants to find out who or what is behind the planned attack and to try and prevent it.

A television screen shows a birds-eye 3D view of your character and the area around him or her (in a rather similar manner to *Ultima VI*). You move around using the cursor keys or a joystick. Items are automatically transferred to your pack when you walk over them - useful if you are in the middle of a fight. A group of commands are displayed at the side of the screen - these allow you to communicate with other characters and manipulate objects.

The plains you must explore encompass four mutie villages, two human townships, an ancient irradiated city, and a hell of a lot of wilderness. If you are to succeed in your quest there are two things you must quickly master - talking and fighting. Making instant decisions as to which of these two actions is the most appropriate is, of course, the most essential skill of all.

You begin with very basic combat equipment - a knife, your bare hands, or a power eye. It is vital that you accumulate some more powerful weaponry quickly, or you will soon find yourself little more than a pile of dry bones in the desert. Neither is wandering around aimlessly likely to be any less deadly. Even if you do manage to equip yourself well, you will ultimately die of starvation or thirst unless you approach your quest in a systematic way. This means questioning every friendly character you encounter, and being sure to follow up any leads you get.

During the early stages of the game the frustration factor can easily set in. There is a lot of questioning, and a lot of trekking to be done, and you are weak and under-equipped. The meat of the game comes once you have found enough equipment and information to give some shape to your quest.

At first, *Bad Blood* seems limited because of the sameness of the early gameplay, and the simple command system that is used. Given some time, however, things soon hot up and the game provides some solid, long term entertainment.

● Laurence Scotford

RELEASE BOX		
PC	£34.99dk	OUT NOW
AMIGA	TBA	
ATARI ST	TBA	
No other versions planned.		

**PC**

If you are lucky enough to have a VGA machine then you can enjoy a stunning colourful opening sequence. The in-game graphics are quite polished and do manage to convey a sense of atmosphere which changes depending on your location. Sound is limited to the odd beep, unless you have an add-on sound board. If this is the case you can play along to a throbbing soundtrack.

GRAPHICS	8	IQ FACTOR	7	ACE RATING	<b>850</b>
AUDIO	5	FUN FACTOR	7		

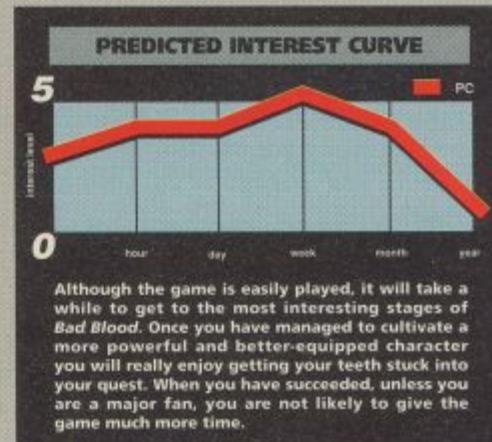

You are under attack, but at least you've acquired some serious heavy weaponry for protection



# A THOUSAND WAYS TO DIE...

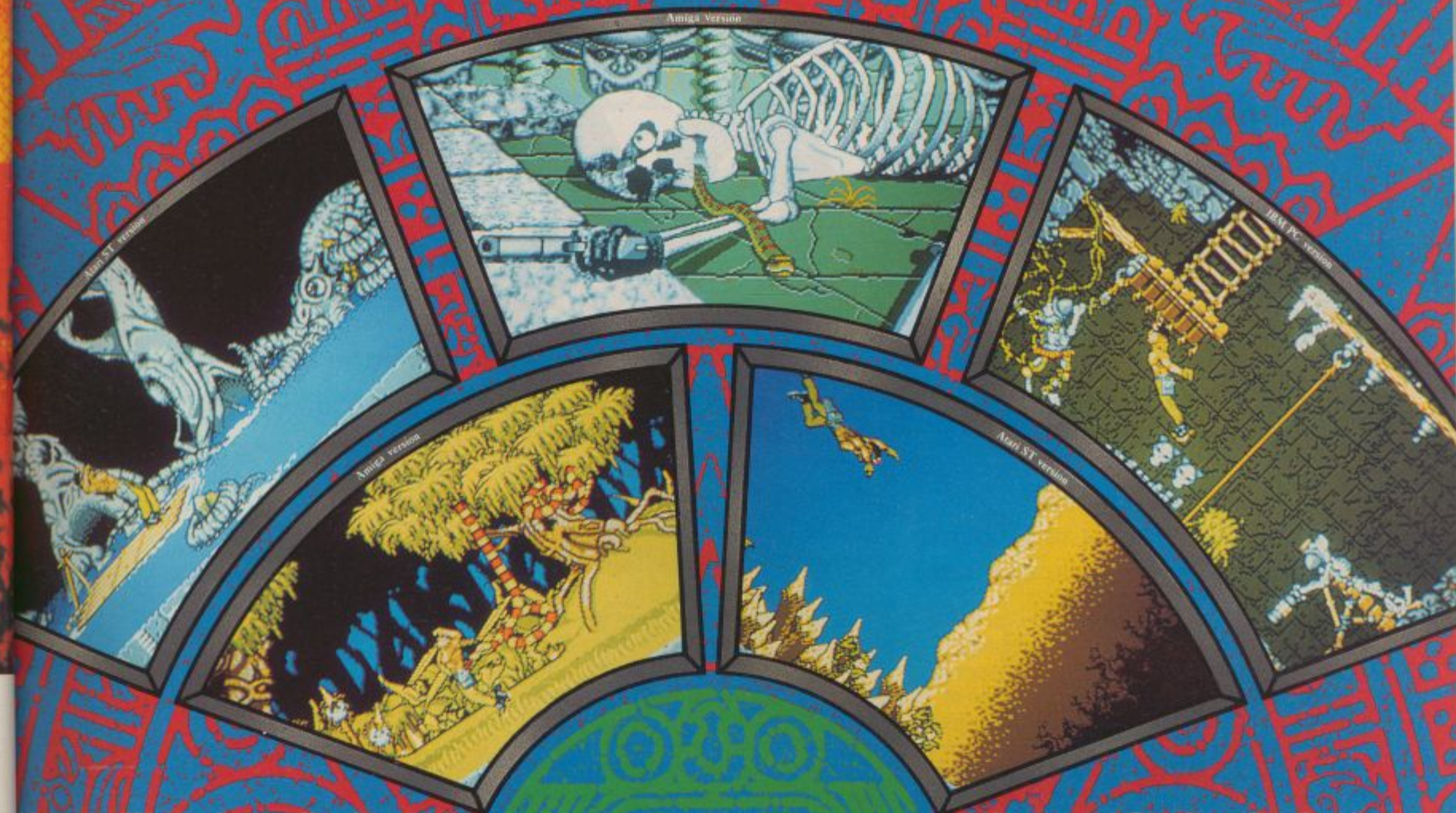

More than 300 men have suffered terrible fates in pursuit of the untold wealth hidden in the Aztec Tomb of Quetzalcoatl. For 400 years no-one has dared to take up the toughest challenge man has ever known, despite the promise of riches beyond imagination. The ancient Mexican treasures are protected by the most evil forces in an underground world of hostile creatures and traps.

Your name is Bret Conrad, and you're not like other men. Your Special Forces training and Vietnam combat duty have made danger a way of life. But this time the odds really are stacked against you. If you succeed in stealing the greatest undiscovered treasure of them all, it'll be a miracle. But be realistic - in the Land of the Aztecs, gold is the passion .... but death is the probability!

## ...BUT ONLY ONE WAY TO STEAL...

AVAILABLE  
ON  
ATARI ST

AMIGA

IBM PC &  
COMPATIBLES



U.S. Gold Ltd, Units 2/3 Holford Way,  
Holford, Birmingham B6 7AX.  
Tel: 021 625 3388.

# THE Gold

## OF THE AZTECS

### VISIT THE LAND OF THE AZTECS!

We think this game is one of the toughest action adventures ever devised. That's why we're giving away the trip of a lifetime to visit the Land of the Aztecs in Mexico next Summer.

To win you have to beat all-comers in

### THE GREAT AZTEC GOLD RUN!

SEE BOX REVERSE FOR DETAILS.

# AMOS

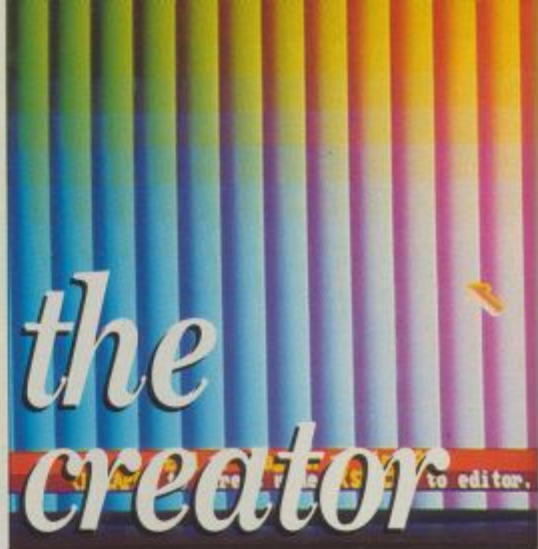

**MANDARIN's game orientated language bring power to the average user**

**N**ot the name of a minor character in The Waltons, but the long awaited Amiga equivalent of the best-selling STOS package for the Atari ST. AMOS is an advanced version of BASIC geared towards games writing. The idea behind both STOS and AMOS is to allow programmers to write games and demos easily in an interactive environment without resorting to the complexities of machine code. AMOS also provides built in routines to control aspects like

**RELEASE BOX**  
**AMIGA** £49.99dk **OUT NOW**

One rather neat feature is that the listing window is totally separate from the run window, unlike in STOS where the two tended to corrupt each other. There is also a direct mode which allows you to enter commands that are obeyed immediately. This is useful for trying out sprite sequences, for instance, before incorporating them into the program. This has been organised cleverly by using a smaller floating window in which commands are entered. This can be moved anywhere over the output window, or even off the screen altogether, so it is easy to see the results of your experiments.



Castle AMOS is one of the examples of how AMOS can be used to create anything from educational software thru arcade games to adventure games

Sprites and scrolling backgrounds, so these don't have to be written from scratch.

Since BASIC is the language that most computer users tend to encounter first, AMOS will be very easy to learn for most people. Unlike the BASIC in STOS, AMOS BASIC does not use line numbers. The listing is also indented to show up loops and other structures. Even if you are already a competent BASIC programmer you will find many commands in AMOS that are unfamiliar to you. These are the special commands that provide features like sprite control, window control, scrolling, and so forth.



The AMOS editor, showing the quick function key commands and indented listing

One problem with AMOS, as with its ST counterpart, is that BASIC, being an interpreted language, is not renowned for it's speed. AMOS overcomes this to a certain extent by having most commands performing little more than calls to self-contained machine code routines. AMOS also makes maximum use of the Amiga's specialised hardware for speed. (See the panel for more details).

STOS has managed to accumulate a veritable horde of add-ons like the STOS compiler (essential for anyone planning to publish their work), and STOS Maestro, the sampler. Undoubtedly AMOS will also be complemented by these add-ons in the near future. The compiler, especially, is one to hope for, because without it AMOS remains little more than a powerful toy.

One area where AMOS is slightly less of a bargain than the ST program is in the support programs supplied with the main utility. STOS had a whole host of small but useful programs to accompany the language, and all of them were fully documented either in the manual or in READ.ME files on the disk. AMOS has only a few support programs



(like a Sprite Designer, and Sprite Grabber), and they are undocumented, leaving the unfortunate user to fathom them out as best as he can.

On the whole, AMOS is an improvement on STOS, and definitely a must for Amiga users who would like to be able to develop their own games, but can't face the thought of learning machine code.

● Laurence Scottford

**WOT ABAHT THE 'ARDWARE?**

The most impressive feature of AMOS is the superb support of the Amiga's specialised hardware. Hardware sprites are fully supported by an interrupt driven sub-language called AMAL, but software techniques are also used to increase the availability of sprites beyond the basic eight per line. The Copper, hardware scrolling, and blitter can also be controlled easily using powerful commands. As an example of the power of AMOS, just one command is required to set up a Dual Playfield, allowing, for instance, blitter objects to be manipulated in the foreground, while an interrupt driven landscape scrolls by uncorrupted in the background.



# One two three.



**SPECIAL OFFER**

Computer Games

Buy 3\* get one  
**Free**



\*Please see reverse for details

... too.

W  
Se  
it  
ou  
... on your card, all you have to do is return to your  
local Boots store. And then we'll give the game away.

A better buy at 

All titles must cost £9.95 or more and be for the same computer. The free offer does not apply to compilations. Subject to availability in larger stores only.



Millenium give you fast 3D graphics, without sacrificing the playability

RELEASE BOX		
ATARI ST	£24.99dk	IMMINENT
AMIGA	£24.99dk	IMMINENT
PC	£29.99dk	OUT NOW
No other versions planned.		

**PC** As with everything else, this is best played in VGA - that way you get the benefit of fully shaded 3D shapes. EGA still looks colourful, but is not quite as subtle. Surprisingly, good use is made of the PC's tinny internal speaker to produce warning alarms, shots, and other effects.

GRAPHICS	9	IQ FACTOR	5	<b>ACE RATING</b> <b>885</b>
AUDIO	6	FUN FACTOR	9	

**PREDICTED INTEREST CURVE**

Easy to play, difficult to get good at. You will probably get through the first couple of levels quite easily before the drones start getting the better of you. With fifty levels spread over five arenas, there is enough action in *Thunderstrike* to keep most gamers happy for a while, but I doubt if there is enough involved in the game to give it long term staying power.

# THUNDERSTRIKE

## MILLENIUM's super-fast 3D flight of fancy

**T**he trouble with flight simulators is they are too difficult to fly!

That sort of statement would probably have purists screaming in disgust, but think about it for a moment. There are lots of games players out there who quite enjoy the experience of flying a plane (albeit a simulated one) at speed, but they are not at all interested in realistic handling or combat. If they can't get the thing in the air easily, and shoot something within the first minute of play they are likely to switch off and load up something else instead.

Millenium seemed to have realised this, and have come up with a game which is bound to appeal to those of you who fall into this category. The plot is quite clichéd - a TV contest set in the far future in which pilots have to defend their home installations against a horde of robotic drone craft. If you think this sounds like something you've seen before, you're probably right. But the hackneyed storyline can be forgiven when the game is this good.

The arena you play in is a chequered rolling landscape over which your craft skims. Your objective is to destroy the drone generators and all of the drones while protecting your ground installations. This is achieved fairly effectively in good ol' shoot 'em up style.

As in all good shoot 'em ups there are bonuses to be had providing you are skilled enough to pick up pods during flight. These range from

more effective shot power to defence pods, which circle your craft protecting you from collisions.

One interesting feature of the Thunderstrike arenas are the tracks that run around the combat zone. These can be utilised in a technique known as Tracklocking. By pulling the craft down onto the tracks you will be sped around the arena at high speed. Lifting the craft away from the track gets you back to normal speed again. On later levels you will certainly need to use this to reach trouble spots quickly.

Because the game is supposed to be a TV show, your view of your craft is from a trailing camera unit. This means that as you sink over a hill the camera loses sight of the craft momentarily while it catches up. Far from being confusing this adds to the impression of speed and motion created by the fast moving landscape.

Control of the craft is easy, especially if you have a mouse, and you will soon find yourself manoeuvring spectacularly in dog-fights with the drones. The more exciting you can make the action, the better - you have to keep the show's audience ratings high.

Two other factors that are taken into consideration during scoring are your success in defending your ground installations and your



The map of the arena is an essential point of reference before you get stuck into defending your installations



hit rate. If either of these are less than satisfactory at the end of each round, then your craft will be downgraded, making it far less manoeuvrable. Perform well, on the other hand, and you will be rewarded with a faster, better craft.

If you are one of those people bored of looking at empty sky from the simulated cockpit of an F-16, 19, 29 or whatever, then you should definitely give this a try. *Thunderstrike* puts the playability back in 3D.

● Laurence Scotford

# NAME the GAME

**Do you want to win a Nintendo Gameboy with loads of great software? Just name this new game from MINDSCAPE !**

A game with infinite levels, *Project X* is the latest release from veteran programmer, Tony Crowther. Taking over a year to write, *Project X* is a radical departure for the programmer of such C64 classics as *Loco*, *Blogger* and *Monty Mole*. Not only is *Project X* his first 16-bit game, it's also his first role-playing game.

Crowther enthuses, "Last year I really got into the role-playing games from Electronic Arts". With this new found enthusiasm for role-playing games, it wasn't long before he decided to write his own epic. "EA's *Wasteland's* was a great inspiration - it pushed me along."

"*Dungeon Master* is the only role-playing game released so far that offers the gameplayer intricacy and, more importantly, atmosphere. I intend to extend these features in *Project X*," states Crowther.



Building up your droids capabilities using the easy icon system

RELEASE BOX		
ATARI ST	£TBAdk	SEPTEMBER
AMIGA	£TBAdk	SEPTEMBER
PC	£TBAdk	DECEMBER
No other versions planned.		

"The game's storyline will be developed in a sci-fi novella included in the finished product. This is the rough outline. You're imprisoned in a huge galactic fortress - orbiting far in the depths of space. You're held simply because you're dangerous - the most evil man in the galaxy. Held deep in a frozen sleep for two hundred years, you're awakened by a fault and miss-function of the holding computer. You then find a brief case with a computer built into it and start to make contact with the outside world. So begins your slow escape to freedom. Trouble is you don't know who you are, where you are or even what to do once you escape."

Basically *Project X* is a sophisticated icon-driven 3D maze game. "You control four droids through the 10 bases that hold the galactic fortress in stationary orbit. They must successfully get through the inside and outside viewpoints of the bases and destroy the power source in each. You use the droids to steal a space craft - getting you to the next base as soon as possible. For it's only a matter of time before your captors notice your escape. The four droids start as simple constructs - you have to build their dexterity, technical and brawling levels."

"The droids are capable of manipulating amazing amounts of technology, weaponry and com-



The vid screens at the top of the screen allow you to use multiple pieces of electro kit such as scanners

puter equipment. Your droids are made up of component parts - *Project X* is the first game that allows you to replace your players legs if they're not walking fast enough! Better heads give better eyesight and hearing power. The game also includes multiple camera control options - allowing the positioning of a camera in a corridor far away from you - to monitor the action elsewhere."

Perhaps the most revolutionary new concept found in *Project X* is Crowther's technique for generating maps for the game. "Architect produces all the level maps in the game automatically. The computer constructs never-ending worlds. As a result the game has an infinite number of levels."

● Rik Haynes

## GRAB A GAMEBOY

Mindscape would like your help to name this game. As a reward for your effort, the leading US software company is generously giving away THREE Nintendo Gameboy handheld consoles with the COMPLETE range of Mindscape Gameboy games cartridges - including the brilliant *Paperboy*, *Days of Thunder* and *Eclipse* games carts. And it doesn't stop there. When the game is released, the lucky winner will have their name on the title screen credits of the game! This has got to be the ultimate competition for gameplayers!

So sit back. Read all about the game. Push your imagination to bust. And think up the most original name for this game. The best three entries will each receive a Gameboy with all the Mindscape games software. Mindscape will then pick the overall winner.

Write your Name the Game suggestion on the back of a postcard and send it to: NAME THE GAME, ACE Magazine, EMAP Images, Priory Court, 30-32 Farringdon Lane, London EC1R 3AU. Don't forget to include your full name and address. Entries must reach us by Thursday 9 August. No employees of Emap Images or Mindscape are eligible for entry. The decision of the judges is final and no correspondence will be entered into.



Adversaries come in all shapes and sizes, from this monster tank to fire breathing dragons and head exploding doormen!

# Flight Departures

## FLIGHT OF THE INTRUDER

MIRRORSOFT/SPECTRUM HOLOBYTE take a flight back to 'Nam in the game of the film of the book

Spectrum Holobyte's first flight sim, *Falcon*, has been widely acclaimed as one of the best simulations yet. It is still selling well and is about to be blessed with another mission disk. Now its creators have come up with something a little different.

*Flight of the Intruder* is based on the book of the same name by Steven Coonts, which has been selling very well over the pond. Well enough, in fact, to attract the attention of the film makers - the movie is due to be released in the US this summer.

Film, book, and game all centre around the US navy's concentrated bombing of key sites in Vietnam during the early 1970's. There are two aircraft featured in the sim - the Intruder of the title, and the better known Phantom. It was the Intruder that undertook the bulk of the bombing missions, while the Phantom, a better plane for dog-fighting, provided it with air support.

It is quite refreshing to play a flight sim without an F-number in sight. I'm sure that you are as tired as I am of the endless streams of Stealth Fighter simulations, based to a large extent on conjectural data. The aircraft featured here are now approaching obsolescence, and the technical specs for both of them are more readily available.

There are a number of missions available, most of which involve taking out threats or destroying strategic buildings and structures (like bridges, SAM emplacements, and suchlike). Your task in each mission will depend to a large extent on which plane you choose to fly. In a bridge strike for instance, it will be the Intruder that actually attempts to take out the bridge, while the Phantom will patrol for, and intercept, incoming Migs.

Although neither of these planes has the sort of sophisticated artificial intelligence systems to be found in the most recent fighters, Spectrum



A phantom on patrol screams in low over some storage silos

Holobyte have included an extensive auto-pilot function. Switch this on and the plane will practically fly the whole mission without human intervention. Although this is far from being realistic it does give beginning players the opportunity to ease themselves gently into the simulation with-



RELEASE BOX	
ATARI ST	TBA
AMIGA	TBA
PC	£TBA JULY

**PC**

It is easy for a game of this type to look impressive on a super-fast 80386 based AT. Nevertheless, *FOTI* does hold its own in terms of smooth flicker-free rendering of both 3D objects and 2D backgrounds (something that a lot of other flight sims fall down on). EGA/VGA screens look good, with reasonably believable colouring for both shapes, land and seascapes. Sound can be switched in and out as required.

GRAPHICS	8	IQ FACTOR	7	ACE RATING
AUDIO	2	FUN FACTOR	6	
				<b>910</b>

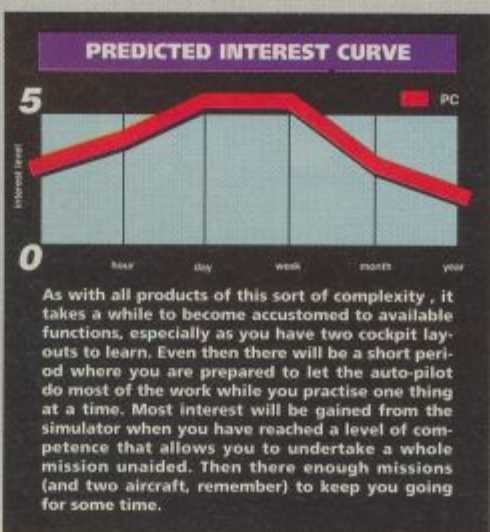

As the planes themselves get more sophisticated, so do the simulations, but they don't all head in the same direction. ACE checks out the bearings for three new high flyers

## F-19 STEALTH FIGHTER

MICROPROSE relaunch the fighter of the decade in new clothing

The PC version of *F-19* has already enjoyed a year of acclaim, and is one of the main contenders for *Falcon*'s crown as the best simulation of a modern fighter. With the launch of new and improved ST and Amiga versions, *F-19 Stealth Fighter* looks like it may well finally establish itself as THE flight sim for those who take their flying seriously.

The trouble with any simulation based on this machine is that there ain't a lot of data available, so things like handling, ordnance capacity, radar signature, and ECM systems that are featured in the sim have to be largely conjectural. You can be sure, however, that a company with a background in simulations will have done its homework thoroughly. So what you get is going to be as close to the real thing as possible.

There are four scenarios built-in: Libya, The Persian Gulf, The North Cape, and Central Europe. Each of these can be played in a num-

out having to worry about everything at once.

There are a whole complement of views from within the cockpit for over the shoulder fans. There are a number of gimmick out-of-cockpit views as well, with the usual rotate and zoom functions. These include a missile view, which follows the missile as it drops down onto ground installations.

With the exception of the auto-pilot feature and one or two more alternative views, *Flight of the Intruder* does not really offer much more in terms of features than other recent flight simulators. What it does offer is the chance to fly two planes not likely to be featured in any other simulators. Taking off from and landing on a carrier is a whole different kettle of fish to doing the same thing on an airstrip. Playability is also superb. *Flight of the Intruder* is definitely recommended if you fancy something a little different.

● Laurence Scottford



ber of conditions from peacetime to all-out war. Within these broad scenarios there are a large number of missions ranging from simple patrols, through reconnaissance, to rapid strikes against selected targets.

One thing that becomes immediately apparent on playing F-19 is the amount of detail that has been packed into the program. A few scattered polygons across a sparse grey landscape that you could drive across in half an hour is, thankfully, not a feature of this game. Instead you are treated to several thousand miles of accurately mapped land and seascapes with highly detailed ground features. The detail also extends to the sky – not only are the movements and phases of the sun and moon correct, but the constellations are set precisely so that you could feasibly navigate by them if you know how.

Microprose have used their own sophisticated shape editor to produce all the 3D shapes in the game, and very nice they are too. They have tried not to skimp on the number of polygons used, especially on complex curved areas. On some of the external views of the F-19, the wings actually look curved (despite the fact that they are constructed of many flat surfaces).

The speed and smoothness with which images are rendered is quite admirable, and watching ground details appear gradually as you close on them is realistic, and not jerky as it is in other inferior sims.

F-19 was impressive enough on the PC. With their added features, these versions seem set to further establish F-19's claim to being the best serious simulator available for fighter enthusiasts. It gets my vote anyway.

● Laurence Scotford

RELEASE BOX		
ATARI ST	£29.99dk	OUT NOW
AMIGA	£29.99dk	IMMINENT
PC	£39.99dk	OUT NOW

**ATARI ST**

The ST is not the easiest machine to implement fast 3D graphics on, but the Tetbury based crew have made a pretty good job of things. Object and ground colourings are all quite good considering the 16-colour limitation. Sound is functional, as is always the case with this type of product. Playability is superb, especially considering you have to use a digital joystick.

GRAPHICS	9	IQ FACTOR	7	ACE RATING <b>935</b>
AUDIO	5	FUN FACTOR	7	

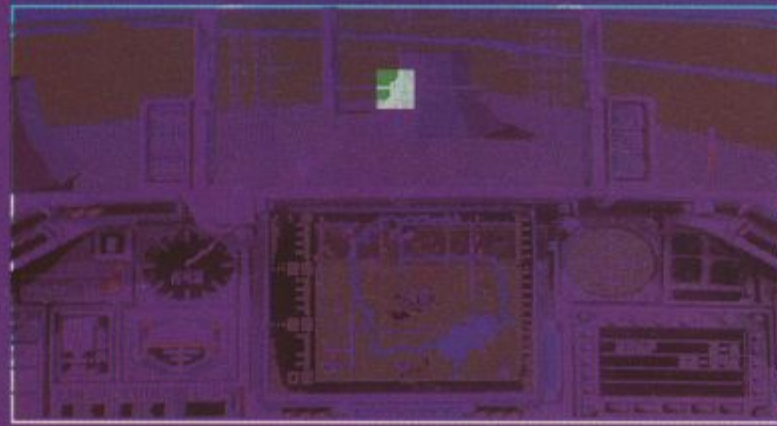

Falcon – getting on a bit, but still playing as well as ever

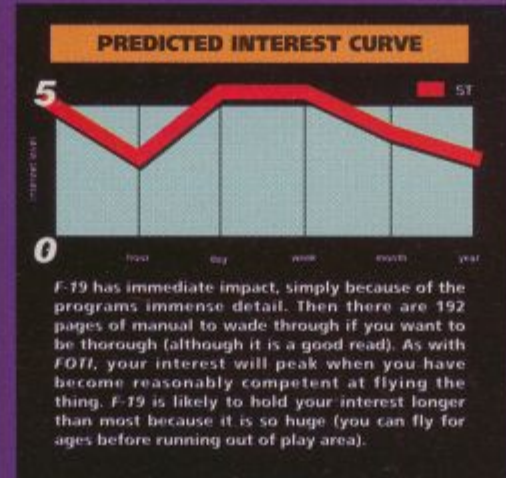

# FALCON MISSION DISK II

Price point: £19.99

Following the roaring success of the first mission disk, Mirrorsoft have once again attempted to improve on their original flight sim 'good idea'. Designed in the same vein as the original mission disk, its sequel replaces the original Falcon disk one, so there's no messy copying or updating.

The first real difference is the missions, they've been completely rewritten. Now the missions range from wiping out pairs of marauding tanks to fighting off a full scale enemy invasion with your airbases under attack. Another feature is the enemy's ability to attack from two different directions on land and in the air, so you need to completely rewrite your tactics otherwise you could find yourself without a place to land.

Helicopters have been added to make life a little tougher. They tend to appear in every mission and hover annoyingly around installations causing a few problems if you need to get in close on a bombing run. And it's not worth wasting a missile on them as they're not too dangerous, so close combat with the cannons is more beneficial.

A modified version of the Sidewinder missile has been added which lets you attack opposing planes before you see them, useful for major campaigns.

The graphics haven't been changed, though there are extra sound effects for expanded machines, which included more nagging remarks from the plane's on board computer, Betty.

Mission Disk II will especially appeal to die hard Falcon maniacs, and for those it comes highly recommended. But Falcon is getting on a bit, so if you're after new experiences in the flight sim market you might be better checking some of the more recent entries in this field.

● Mark Patterson

The cockpit of the Stealth Fighter is remarkably bare – most of the important info is displayed on the HUD

## SECOND OPINION

I expected this to be a hard game to start with. Other simulators I have played have been too difficult for the beginner. But as soon as I was in the cockpit of the F-19 I found that I could fly the plane and reach the waypoints, yet the dog-fighting was as challenging as it should be. The reason for F-19 being so easy to start and enjoy is that Microprose have set the difficulty level perfectly for the beginner although you can easily make the game harder for yourself as you get more competent. Also for the beginner is the sophisticated auto pilot, which can usefully get you back on course.

Overall I really enjoyed playing the game. The plane handles well and does not react heavily to stick movements like F29 Retaliator. F19 is very complex though and will take a lot of practise and time if you are to get the most out of it. But as you progress through the missions I am sure the game will become even more enjoyable and the lasting interest will be very good.

ce Scotford





# UP YOUR PERISCOPE, MATEY!

What kind of game does the Navy play? MARCONI's new *Periscope Simulator*!

"A submarine's periscope is a vital sensor. It ensures safe navigation of the submarine in close water or harbour approach manoeuvres and provides the final identification and data to complete attack scenarios. The Periscope Operator is a key link in the command chain, with skills demanding uncompromising excellence in training."



Marconi's *Periscope Simulator* offers "true obscuration and multi-target capability"

"The Marconi *Periscope Simulator* makes training more effective and cost-efficient by providing a dedicated safe environment in which to carry out procedures of periscope operation."

"The Marconi approach enables initial or continuation training in both recognition and operational procedures related to the periscope



Run silent, run deep with *Silent Service II*

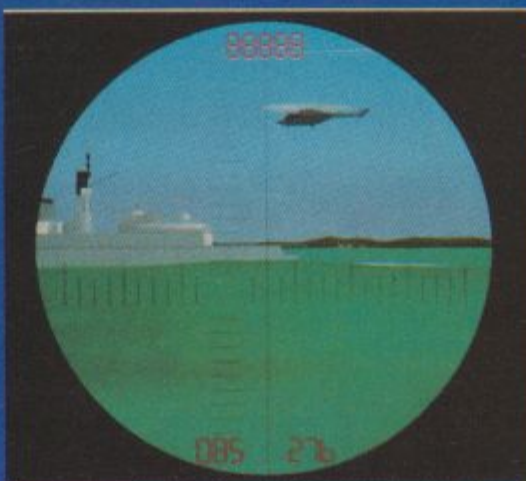

Marconi Simulation provides trainers and simulators for Naval Forces around the world

## RELEASE BOX

**SIMULATOR** Over £1 million OUT NOW

No other versions planned.

being simulated which may be of any type or design. The *Periscope Simulator* provides realistic training in search routines and attack procedures, with in-shore or open-water navigation in a multi-ship scenario, under normal or emergency conditions."

"To the operator the periscope feels and operates just as in the real submarine. Even the rotational inertia is simulated for added realism."

"The Marconi *Periscope Simulator* represents a significant advance in simulation technology. It incorporates high-resolution graphics for seascape, land and image generation using sophisticated software techniques which provide high levels of realism for the user. In particular, the fidelity of ship modelling provides sufficient detail of superstructure and major features to enable vessel identification and accurate assessment of range, bearing and angle on the bow."

"Advanced visual systems based on commercially available graphics engines of high performance provide the best means of representing day, dusk and

## SILENT SERVICE II

If you like the idea of Marconi's *Periscope Simulator*, but don't fancy joining the Navy to play with one, why not try Microprose's new sub-sim?

"*Silent Service II* is a modernised version of *Silent Service*, the award-winning simulation of World War Two submarine action in the Pacific. It contains a training game, convoy attacks and war patrols, and also has a full campaign game in which you develop a career as a submarine commander."

"The game provides action in the South Pacific with mission objectives that include hunting military shipping in addition to merchant shipping and encountering enemy warships. At the conclusion of convoy attack and war patrol scenarios, a time lapse replay of the action is displayed to allow you to review your successes and learn from your failures."

"Each enemy ship is portrayed using digitised photographs taken from 24 perspectives. External views of the submarine show torpedoes being launched and depth charges spiralling from above and exploding near, sometimes fatally near, your boat."

*Silent Service* is due for imminent release on PC and supports CGA, EGA, VGA, MCGA graphics modes and AdLib and Roland sound synthesizers. ST and Amiga versions are expected to follow later in the year.

night scenes in a variety of weather and sea-state conditions. All aspects of the periscope picture, such as graticule and data displays, are reproduced, providing total control from a single system."

"The visual technology built into the *Periscope Simulator* is also used to great effect in gunnery training and is directly applicable to other 'view-through-sight' trainers. Versions of the technology are used in other visual-based trainers such as Flight and Ship Bridge simulators."

"The Marconi Simulation *Periscope Simulator*... a sight nearer to reality."

● Rik Haynes

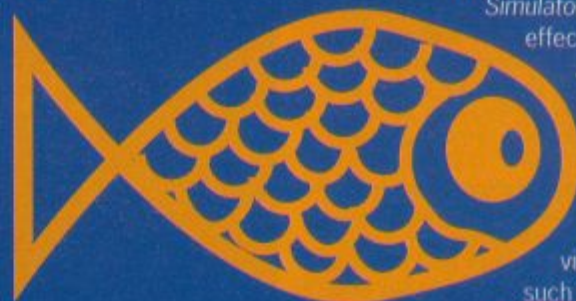



# HEROES

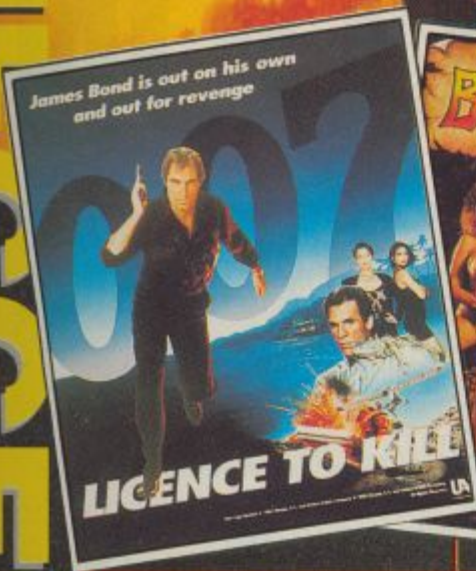

## 4 LEGENDARY HEROES • 1 BLOCKBUSTING COMPILATION

**LICENCE TO KILL**  
Bond is back to take revenge on Sanchez, the evil, double dealing drugs baron. Can you beat the odds and deliver the goods?  
"... excellent graphics and sound make this by far the best Bond game to date... a brilliant game in its own right." Computer & Video Games



Amiga & Atari ST Screenshots

**BARBARIAN II**  
Hack 'n' slay action. Gristly traps and hideous monsters await in the Dungeons of Drax. The most successful hero ever created for home computers.  
"By far the best (and goriest) beat 'em up..." Zap! 64



**THE RUNNING MAN**  
It's Showtime! Face death in the most dangerous game show of all time!  
"... a perfect computer game... Stirling stuff" Your Sinclair



**STAR WARS**  
Join the ultimate Sci-fi hero Luke Skywalker in a death-defying last ditch attempt to blow up Darth Vader's stronghold, the Deathstar.  
"Classic film, classic coin-op, classic game" Computer & Video Games



Available on: Atari ST, Amiga, Commodore 64 (cassette, disk) Amstrad (cassette, disk) Spectrum +3, Spectrum 48/128



Published by Domark Ltd, Ferry House, 51-57 Lacy Road, London SW15 1PR Tel: 081-780 2224

The Running Man: © 1989 Taft Entertainment Motion Pictures/Keith Barish Productions.  
© 1989 Grandslam Entertainment Ltd.  
Barbarian II: © Palace Software 1988  
Star Wars: ® & © 1987 Lucasfilm Ltd & Atari Games  
Licence to Kill: Distributed by MGM/UA Distribution Co.  
Gun Logo Symbol © 1982 Danjaq, S.A. and United Artists Company. All Rights Reserved.

!

scope  
e  
acks  
o a  
South

of  
o  
ng  
g  
b  
d  
w

ea-  
ope  
s, are  
single  
scope  
great  
ring

other  
'sight'  
ions  
logy  
ther  
ers  
'ip'

Haynes

SCHWARZENEGGER • BOND

SKYWALKER • BARBARIAN

The 4-2-0 is not exactly a candidate for an Intercity 125 line, but it's a start...

Nothing like Network SouthEast, but once your Empire grows to a reasonable size you'll face similar problems to BR's bosses

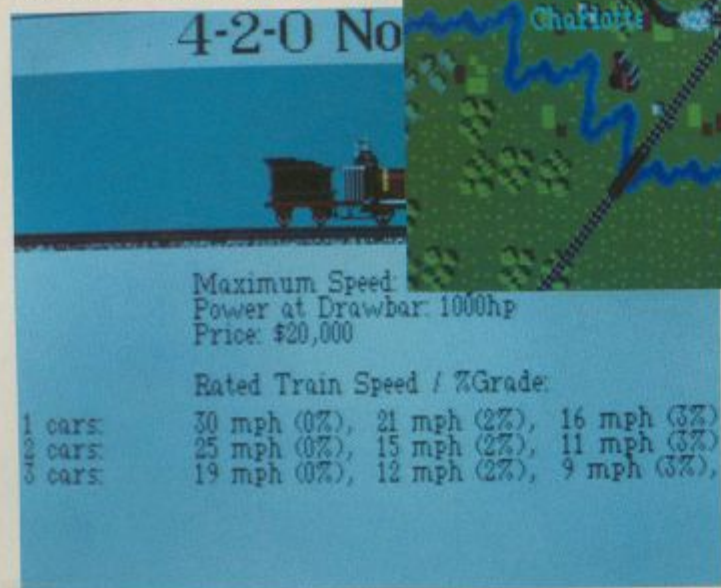

4-2-0 No

Maximum Speed:  
Power at Drawbar: 1000hp  
Price: \$20,000

Rated Train Speed / %Grade:

1 cars:	30 mph (0%),	21 mph (2%),	16 mph (3%)
2 cars:	25 mph (0%),	15 mph (2%),	11 mph (3%)
3 cars:	19 mph (0%),	12 mph (2%),	9 mph (3%)

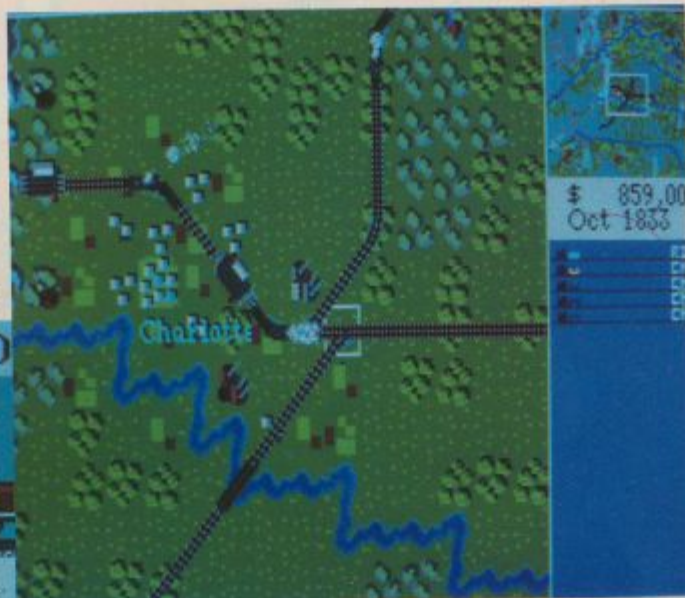

# RAILROAD TYCOON

## MICROPROSE give you the chance to outdo BR and build your own Railroad Empire

Being thrown to the mercy of British Rail every morning and evening, my train association is a pretty ghastly one; leaves on the line, points and overhead power cable failures and a myriad of glib and criminally insincere apologies. If you've had similar problems and think that you could run a railway system better, here's the chance to put your money where your mouth is and risk the wrath of a million commuters as you build your very own rail empire.

Options at the start of the game let you choose one of four scenarios, England, Europe and Eastern and Western America (the starting varying from 1828 to 1900 depending on the location), and one of four difficulty levels.

The map where the action is set is accurate, with all main towns and cities included. Only landscape features, such as mountains, lakes, farms, mines, chemical plants and steel mills are randomly generated.

The seeds of your empire are sown by building a track between two reasonably close conurbations and running a train service between them. Since this is an historically accurate program, at the start of the game train technology is poor. As the game progresses through time, new trains are "invented" and can be bought to replace your out-of-date units. But

for now you have to bite the bullet and suffer with a jalopy that does 15mph tops with two carriages.

Money is earned every time a train arrives at a station with a load. Obviously the more carried, the more revenue is generated. And with more money, you can build your track further afield, buy shares in other railroads with takeover bids in mind, or even improve your stations with hotels, restaurants, large storage areas and the like!

Any station built in an urban environment produces mail and passengers. If its catchment area includes such features as a harbour, farm or mine, goods are produced, which can be taken to other stations for even more revenue!

### THE INDUSTRIOUS INDUSTRIALIST

The key to growing your empire lies in supply and demand. At first this seems simple: take goods from one place and dump them somewhere where they can be consumed. Not so. A more intelligent railroad operator will spot areas where goods can be taken and made into other commodities to be picked up later and deposited elsewhere, such as coals to a steel mill to make steel, cotton to a textiles mill to produce textiles, hops to a brewery for beer, and steel to factories to end up with manufactured goods. This method of play produces more than double normal revenue, since manufactured goods are worth more than raw goods, and gives you a firm footing for the future.

**RELEASE BOX**

PC £34.95dk OUT NOW

No other versions planned.

**PC**

All graphics cards are catered for. Obviously VGA is tops, but EGA is a jolly colourful whizz, and even in putrid CGA the action is still crystal clear. Sound is pretty good, with effective train noises on the standard squeaker speaker - sound cards offer the benefit of atmospheric music and FX. Best of all, though, is that you don't need to own a 25 Mhz stonker PC to appreciate the game. *Railroad Tycoon* runs happily even on the crummiest machines.

GRAPHICS	7	IQ FACTOR	9	ACE RATING
AUDIO	5	FUN FACTOR	9	<b>943</b>

**PREDICTED INTEREST CURVE**

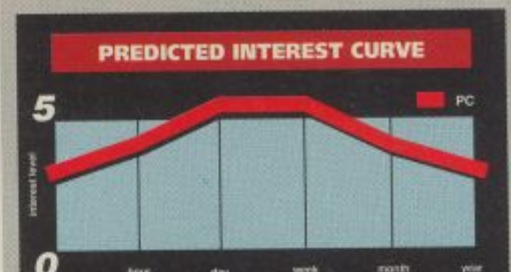

Obviously this is not the sort of game you can just plough straight into. There is a fairly substantial manual to be absorbed first. Once you got a grasp of the basic principles behind the game you can really begin to enjoy yourself. Soon you will be building railroads to your hearts content, and for a good while too!

Keeping track of the supply and demand is easy at first, but as more trains and stations are added, the action becomes increasingly more frantic as you re-schedule your vast train roster and tweak your sprawling track network to ensure optimum performance.

And that's where *Railroad Tycoon's* winning formula lies. At the very outset you're irresistibly drawn into the action, and within minutes you begin to swiftly climb a horrible and very steep exponential curve of addiction as the game makes greater and greater demands on your concentration. Hours fly by, sleep is lost, and in my case, even entire weekends get taken up as you become a bigger and bigger Railroad God.

Put simply, *Railroad Tycoon* is an absolute classic. A game that gives your brain one of the most stimulating and enjoyable neural work-outs yet devised. Surely that's what computer gaming is all about.

● Julian Rignall

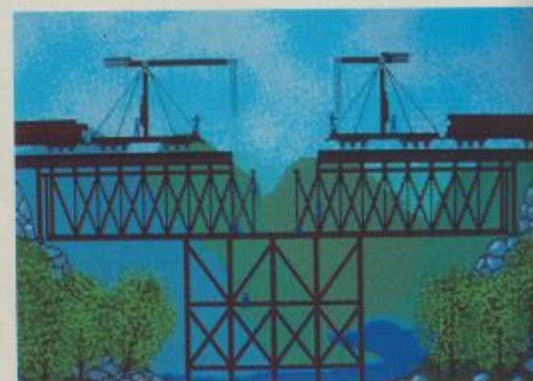

Hurrah! Hurrah! The final piece of track is about to be laid, and the trains can begin to run

# DELIVERANCE

**HEWSON continue to play with fairies in Stormlord II**

Not so much a sequel of the amazing arcade adventure *Stormlord* as a continuation – rather like an extra set of levels, only this time the puzzles are fiendishly difficult and the enemies are some of the toughest I've ever come across.

But to the story. The Viking stormlord (for the sake of argument, let's call him Lars), pleased with his success in rescuing all the enslaved fairies, took a few moments well-earned rest. In the few short days he slept, all the little folk were captured again, and this time hidden even deeper within the evil realms populated by stumpy fire-breathing dragons and naked rampant nymphettes (I kid you not). Fool that he is, Lars awakes from his slumber, wolfs down his Raisin Splitz and heads back into hell.

The game system is essentially the same as that in *Stormlord*. Collect objects and deposit them elsewhere to solve problems. Move the honey to distract the bees, and so on. Only this time things aren't quite as obvious as they were before. The bad guys and the tasks aren't the only things that have been improved, the



The fairies have been captured again – can our Nordic hero save the day?

weapons you can collect along the way have progressed too. My personal favourite is a small bouncing bomb that, if fired correctly, can take out a fair few nasties before disappearing off either side of the screen.

*Deliverance* is a slight improvement over the first game, but is nowhere near as progressive as it could have been. If you already have the first one then there might not be enough in this sequel to tempt you.

● Tony Dillon

## RELEASE BOX

<b>SPECTRUM</b>	£10.99cs	£14.99dk	OUT NOW
<b>C64/128</b>	£10.99cs	14.99dk	IMMINENT
<b>AMSTRAD</b>	£10.99cs	14.99dk	IMMINENT

## SPECTRUM

A good use of colour on the huge sprites make the game very attractive until things start moving, at which point colour clash abounds. I found the controls to be rather sluggish at times, and the sheer size of everything in comparison to the small playing area makes evasion impossible for the most part. That, coupled with some over difficult puzzles, makes the game genuinely frustrating.

GRAPHICS	7	IQ FACTOR	9	ACE RATING
AUDIO	6	FUN FACTOR	7	

**720**

## PREDICTED INTEREST CURVE

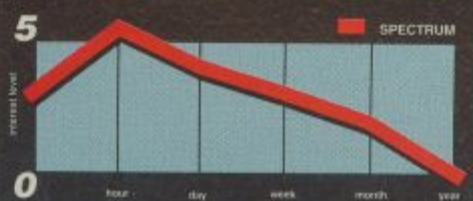

Initial interest is spurred by the nice graphics, and you do get hooked as you progress into the game. Soon, however, you realise there isn't too much in the way of variety and the game soon finds its way back onto the shelf.

# POWER BOAT USA

**ACCOLADE slip into their expensive designer suits and take to the waters around Miami**

Of all the tenuous links that could have been used to sell a game, one of the least likely seems to be between speedboat racing and *Miami Vice*, but here it is. There's even a quote from Don Johnson in the manual, not to mention the custom Scarab 43, subtly named the Don Johnson special.

Powerboat racing is a pretty exciting sport, and the opportunity to compete in the US Grand tournament isn't one to be passed off lightly. Comprising of six tough courses based in and

around the coastal waters of Miami and San Francisco, winning the tournament is anything but easy, but the rewards are worth fighting for.

Each 'course' is marked out by buoys on each bend, and as the bends can be quite far apart you find yourself speeding across large areas of unmarked water, which is where your navigational skills come in. You can fly by the nav points and the compass, but it's far easier just to switch to the map screen now and again.

The race is run using first person perspective filled vectors that are smooth, fast and totally adjustable. For example, you can lower the number of polygons used on your boat to speed the game up, or increase the frame rate to make the action smoother, if not a little slower. Also, in true flight sim style, there is an external view option, which effectively gives you a wider field of vision.

Even though it's packed with options and plays nicely, I couldn't help getting bored with *Powerboat USA* almost immediately. Speedboat racing is highly exhilarating and I was a bit dubious as to whether Accolade were going to be able to capture that feeling of a throbbing monster beneath your legs. As it happens, they didn't.

● Tony Dillon

## RELEASE BOX

<b>PC</b>	£24.99dk	OUT NOW
<b>C64/128</b>	£9.99cs	16.99dk
<b>AMIGA</b>	24.99dk	IMMINENT

## PC

A wide smattering of options tailor the game for any PC, though I was surprised to see the lack of support for any other sound systems. The keyboard response is slow, and over compensation is far too easy. Though based around an original topic, it doesn't strike me as a very original game.

GRAPHICS	7	IQ FACTOR	6	ACE RATING
AUDIO	2	FUN FACTOR	5	

**655**

## PREDICTED INTEREST CURVE

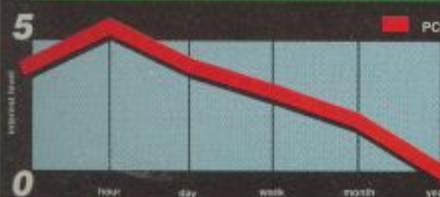

As *Powerboat USA* is a very easy game to pick up, you can get stuck right in from the word go. You soon realise, however, how repetitive the game becomes, and then interest wanes. After that, it's downhill all the way.

Experience all the thrills and spills of Powerboat racing in glorious 3D



# BSS JANE SEYMOUR

**GREMLIN try their collective hands at a bit of DIY aboard a fleet beleaguered starships**

Whatever the title may suggest, *Federation Quest* has absolutely nothing to do with a certain famous actress. It is actually the story of one man's struggle to save a fleet of twenty biological survey ships that flew too close to a star and suffered massive system damage.



One of the mutations - a Tyrannosaurus Rex. The revealed skull shows that he's already had a good couple of chunks out of you

The aim is to travel around the three decks of each ship, collecting items to fix the various parts of the ships, such as life support, computer, and laboratory-systems.

The only real problem seems to be the eight-million years worth of mutation that has consumed the irradiated crew, and the life forms that were under investigation at the time of the accident. As there are quite a few mutants wandering the decks, all bent on killing you on sight, they cause a fair problem.

Along the lines of Ubisoft's *Zombi*, the mouse controls all movement and object manipulation by clicking on different icons. A cluster of arrows at the top of the screen move you around in the 3D universe, while icons at the bottom of the screen gave you access to inventory, droid program and computer screens.

Visually, the game is very impressive. The first person perspective window works well, and all the graphics are colourful and instantly recognisable.

It's not an easy game, by any standards. It's size in one of the things that increases its difficulty, along with some obscure puzzles. If this doesn't keep you playing for years, nothing will.

● Tony Dillon

## RELEASE BOX

ATARI ST	£24.99dk	IMMINENT
AMIGA	£19.99dk	OUT NOW

No other versions planned.

AMIGA

Bright and attractive, the game makes good use of the Amiga's sound capabilities. The sound works well, even if a little sparse in places. *FQ* is surprisingly addictive for a game of this style, but maddeningly frustrating at times. A fair bit of brain power is needed which means this may not be everybody's cup of tea.

GRAPHICS	8	IQ FACTOR	8	ACE RATING <b>810</b>
AUDIO	6	FUN FACTOR	8	

## PREDICTED INTEREST CURVE

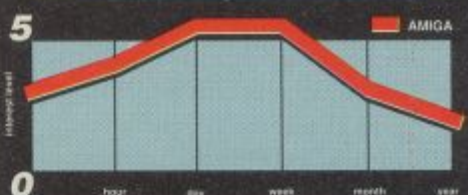

Initial aimlessness puts a damper on a quick start, but once you get your bearings, the game starts to fly along. There are no real secrets to finishing it, so the challenge is always there, and it's the kind of challenge you'll always want to meet. Frustration is the only thing that'll stop you playing.

# CHESS CHAMPION 2175

**OXFORD SOFTWARE produce a powerful Chess program with a humorous touch**

Since computer games began, a whole library of chess games have appeared. The latest being Oxford Software's offering. This effort has all the features possessed by many previous chess incarnations and many more.

*Chess Champion* like nearly all chess programs can be played in 3D or in 2D mode. The difference between *Chess Champion* and many others is that, in the 3D mode, you are not restricted to normal chess pieces, but you can choose between characters from 'Animal Farm', a selection of toys, Sci-Fi, and Chunky pieces. The only problem with this wide range of pieces is that they can not be employed during 2D mode.

2D mode is more useful for showing the square references and the places on the chess board are much clearer. Other options include the ability to Take Back moves.

The only problem with *Chess Champion* is the computer's slow response. This can be speeded up by pressing a couple of keys but it is still annoying having to wait so long every time the computer makes a move.

The different character's used for the chess pieces are amongst the best that I have seen, only beaten by *Battle Chess* which has great animated fighting chess pieces. But *Chess Champion* is much more complex and with many more options.

Unless you are a connoisseur of chess games or have beaten your old chess program then it is probably not worth upgrading to *Chess Champion 2175*.

● Ben Mitchell



Cute ain't they. Alternative Chess Pieces are just one of the features offered by *Chess Champion*.

## RELEASE BOX

ATARI ST	£29.95dk	OUT NOW
AMIGA	£29.95dk	IMMINENT
PC	£29.95dk	IMMINENT

No other versions planned.

ATARI ST

All the chess pieces are well drawn - it's only a shame they are not animated. The colours of the chessboard can be user-defined so the colour scheme can be to your liking. There is a severe lack of spot effects, only a small beep when an illegal move is attempted.

GRAPHICS	8	IQ FACTOR	9	ACE RATING <b>700</b>
AUDIO	2	FUN FACTOR	5	

## PREDICTED INTEREST CURVE

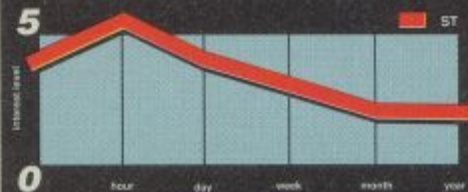

The cute alternative pieces are a good way to hook the less dedicated player, but the novelty soon wears off. When it comes down to the nitty gritty, *Chess Champion* has enough options to keep you going, but it takes too long to respond.

# UMS II

Do they try to maintain diplomatic relations while waging war on a single front, or, like Napoleon for instance, attack on multiple fronts? Being able to adjust features like this not only allows you to design scenarios and generals from scratch, but also to modify IDL's own scenarios if you disagree with their parameters, or simply wish to experiment.

*UMS II* deserves to be an even bigger success than its predecessor. It offers much to the casual gamer, as well as the dedicated war gamer. It is nice to see a product which will appeal to educational, entertainment, and serious markets, and which has evidently been lavished with lots of Tender Loving Care. Just what computers were made for!

● Laurence Scottford

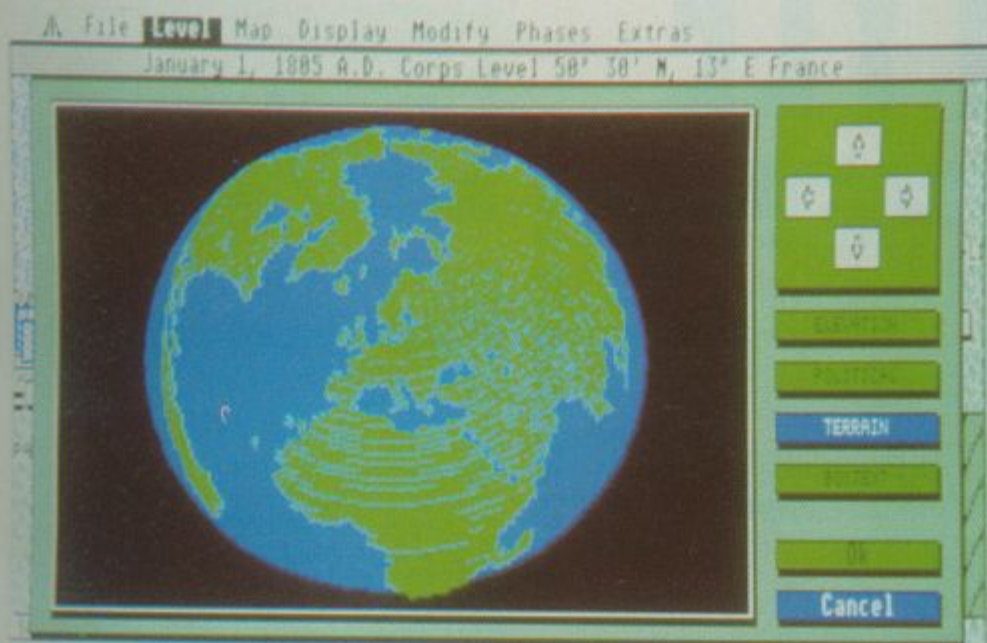

The whole globe can be viewed, allowing you to easily select locations to zoom in on

## MICROPROSE/INTER-GALACTIC DEVELOPMENT go to war for the second time - against a whole planet...

A month ago, if you were looking for a versatile simulator of military actions there was only one decent contender: *Universal Military Simulator*. Now that is no longer the case. By the time you read this, Microprose will have released a bigger brother for the first program, imaginatively titled: *UMS II*. What *UMS* did for single battles, *UMS II* does for planetwide warfare, and more besides.

As with the original program the presentation of *UMS II* is attractively functional. This makes it perhaps, slightly less visually appealing than lesser war simulations, but the depth and detail of the program is nothing less than astounding. Conflicts across an entire planet can be simulated (they need not necessarily be modelled on Earth). Because the program is entirely data driven, virtually any parameter can be altered, so it is a simple matter to represent the fighting conditions for any epoch, or even a totally invented



Most of the parameters can be easily adjusted using slider bar

time and place. You can even set up weather systems to see, for instance, the effects of storms upon troop movement and fighting, or how battle is affected in a dry and arid atmosphere.

One thing that *UMS II* does lack are the three-dimensional views of the battlefield. These are replaced by a more traditional birds-eye view of the area, with units shown as stacked tiles rather than flags. This is not really any great loss, especially as the map view can be shown in several modes, one of which reveals elevation.

Everything from giving orders to editing the scenarios is done via the graphical interface native to the machine you are running the program on, so it should not take too long to get used to controlling all the aspects of the program. Having said that, *UMS II* is so large and so detailed that you will probably still be encountering features months after first using it.

One of the nicer touches in this simulation is the personalised stationary and theme tune for each commander. If you choose to print battle reports they will be printed with the letterhead belonging to the commander you are playing.

Another feature that will appeal to war gamers is the ability to 'design' generals by altering the Artificial Intelligence parameters. This is done by tailoring specific aspects of their personality and decision making. Are they aggressive or passive?

## PENTAGON PEDIGREE

If you want some idea of the esteem afforded to the original *UMS* program then you need look no further than a certain famous five-sided building in the United States. Yes, even the boys who do it for real at the Pentagon opted for *UMS* when they wanted a low cost package for training purposes. In fact, they were so impressed by the simulator that they went out and bought new machines just to run it. A similar level of interest has already been shown towards *UMS II*.

But don't the Pentagon already have some pretty tasty hardware? You're damn right they do - a powerful VAX mini-computer is employed to handle training simulations. Trouble is, it takes two weeks to set up a full scale simulation on the Vax, compared to a few hours on *UMS*! The Pentagon's impatience to have things up and running quickly is reinforced by an anecdote that Ezra Sidram, the game's creator, related to me during his demonstration. One day he received a phone call from a frustrated officer who had been sat in front of a machine running *UMS* and left to get on with it. Eventually the man chose to come clean about his problem. "Boy," he said, "I just wanna shoot some lead!" Hmmm...

## RELEASE BOX

ATARI ST	£24.99dk	AUGUST
AMIGA	£24.99dk	AUGUST
PC	£24.99dk	AUGUST
MACINTOSH	£34.99dk	AUGUST
APPLE II	£24.99dk	AUGUST

No other versions planned.



1805: Napoleon's troops get ready to invade Britain while the Austro-Russian army creeps in from the East

# PROJECTYLE

**ELECTRONIC ARTS bounce back with twenty-first century footie**

**S**aturday afternoon recreation in the far future will not be boring old football or rugby, but an exciting new projectile game called Tribal. The basic idea behind Tribal is very simple: knock a spherical thingy around a pitch in an attempt to get it into your opponents' goals before they get it into yours. I know what your thinking – that sounds just like Footie. There are substantial differences however.

Tribal is played on a walled-in pitch divided into four sectors connected via tunnels to a central neutral sector. Each game is played by three teams (tribes) of five players (with one occupying each sector). Three of the outer sectors contain a single goal defended by one of the tribes, with the fourth outer sector having three goals (one for each of the tribes).

Players move the projectile by actually bouncing against it. Moving the joystick will cause the player to move slowly in the direction indicated, while pressing the fire button will cause the player to slide rapidly towards the projectile.



Projectyle is fast moving fun with bouncing spherical thingies...

What makes Tribal fun to play is that each tribe has a home pitch made of a different type of material. This affects the way that the projectile moves and the way that the players move, so each pitch requires totally different tactics. Even the projectile changes (sometimes it is a squidgy blob of protoplasm, at other times a hard, fragile ball which is easily crushed if you collide with it too harshly).

Play is further complicated by the bonus objects which appear from time to time. These have a number of effects (either helpful or detrimental) on players, projectile, and pitch. There are also tempting deposits of dosh to be



Apocalypse treats you to fast solid 3D graphics and frantic action

**A**n action packed voyage of annihilation and destruction, featuring some of the most impressive graphics yet seen on the Archimedes is what Apocalypse is all about.

The Rakonans, an evil breed of superbeing, have conquered the solar system and wiped out all human lifeforms. As one of the last remaining pilots of the Guild of Spacing, your mission is to seek out and destroy all Rakonian forces.

The guild can regain control of a planet once 95% of Rakonian defences have been destroyed. This is no easy task though, as some planets have over 1000 settlements and defences protecting them. Not a simple job for your small Llanerk ship.

There are two planets you can initially choose to attack, more can be selected once you have proved your skill to the Guild. Your progress can be saved to disk and reloaded for future games.

Once you have chosen your assault route, via a map of planet's surface, the flight down to the planet is shown in an impressive 3D sequence. Safely down, you can manoeuvre your ship

# APOCALYPSE

**The 4TH DIMENSION sets a new standard in Archimedes action**

across the surface destroying anything that moves (or anything that doesn't for that matter). The ship is controlled with the mouse - left and middle buttons give forward and reverse acceleration respectively, with the right button firing your laser canon. Unlike many previous games of this type, control is very positive, leading to fast addictive action.

All the buildings and enemy craft are shown in superb flicker free detail, even down to the doors and windows on the houses. The power of the Archie comes into its own here - the incredible processor speed allows all the surfaces to be fully shaded and filled in, without slowing down the hectic action.

Sounds are well implemented too, with many samples, effects and stereo explosions. Definitely a game to keep the neighbours up! (It's a good thing that a volume control is provided).

Colourful, fast action, along with ease of play and addictiveness ensure that this will be an all-time classic for the Archimedes.

RELEASE BOX		
ATARI ST	£24.99dk	OUT NOW
AMIGA	£24.99dk	IMMINENT
No other versions planned		

ATARI ST	Although neither graphics or sound are particularly stretching the machine, the presentation is very slick. This is the sort of game where playability is everything, and that aspect of Projectyle is certainly superb.			
	GRAPHICS	6	IQ FACTOR	3
AUDIO	6	FUN FACTOR	8	<b>750</b>

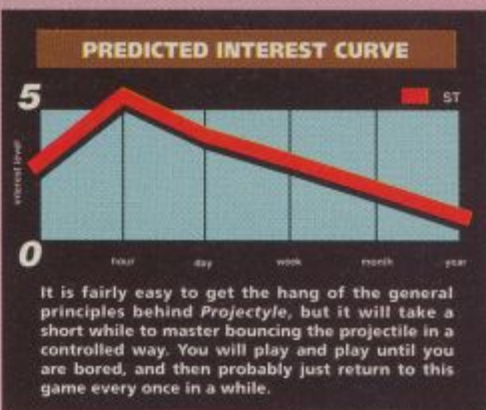

collected. This money can be used for training to increase your players' skills between matches.

Projectyle is a fast moving fun game. The idea is not that original – as Speedball, Ballistix, and similar fare will testify, but it is well executed. If you enjoy a bit of rapid joystick bashing which doesn't really put any strain on the old grey matter, then this is for you.

● Laurence Scottford

RELEASE BOX		
ARCHIMEDES	£29.95dk	OUT NOW
No other versions planned		

ARCHIMEDES	Although rapidly gaining in popularity, the Archimedes has yet to take off as a games machine – there are only a handful of games available that fully exploit the power and speed of the machine. Apocalypse incorporates some of the fastest and smoothest graphics yet seen on the Archie.			
	GRAPHICS	9	IQ FACTOR	6
AUDIO	8	FUN FACTOR	9	<b>875</b>

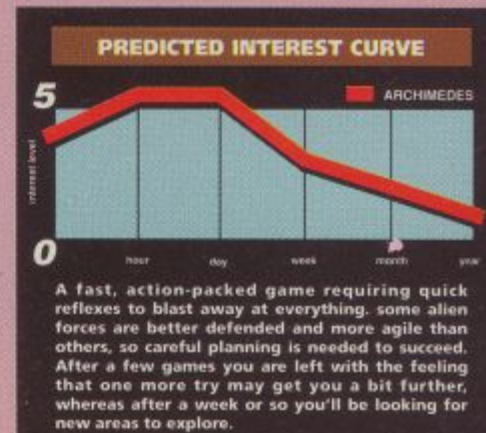

● Paul Vigay

# Quickjoy

## Joysticks



124-TURBO  
6 Microswitches.  
Autofire. £9.95



120-JUNIOR STICK  
Twin Fire Buttons.  
Hand Held. £6.95



119-JUNIOR  
Twin Fire Buttons.  
£5.95



127-TOP STAR  
Steel Shaft.  
Microswitches.  
Autofire. £22.95



125-SUPERBOARD  
10 Microswitches.  
Digital Stopwatch.  
Autofire. £19.95



126-JETFIGHTER  
6 Microswitches.  
New Pilot Grip.  
Autofire. £14.95

II PILOT



£7.95

122

SUPERCHARGER



£10.95

123

INFRARED



£39.95

130

M5 FOR IBM PC.



£19.95

201

QUICKJOY JOYSTICKS. Leading in design, technology and choice. Check out the range and features. Buy with confidence.

\*Now available from Larger Branches of....

WH SMITH

John Menzies

Selfridges

Hamleys

.... and all good computer dealers.

SPECTRAVIDEO

Unit 27 Northfield Industrial Estate, Beresford Avenue, Wembley, Middlesex HA0 1NU England.

Telephone: 01-900 0024

Facsimile: 01-903 6625

# LOOK BEFORE YOU

Platform games suddenly seem to be flavour of the month again. Veteran gamer Eugene Lacey steps out and puts three of the latest contenders through their paces

## TURRICAN

Magazine awards at the end of RAINBOW ARTS latest opus

Just when you thought platform games could go no further, along comes *Turrican*, to be instantly showered with awards and accolades by the cartload. But is the finished product worthy of all this hyperbole? Yes, most definitely. It is technically superb yet low on originality – it borrows all of its game plan from various recent coin-ops, but the resulting mixture turns out to be an arcade style game worthy of merit.

*Turrican* leaves the other two platform offerings on this page for dead. Whilst *Flood* and *Prophecy* are mainly about

repopularising cute platform games on 16-bit machines, *Turrican* is attempting something altogether more interesting. It takes the platform/shoot 'em up/adventure hybrid from the arcades (Best examples of the genre being Data East's *Midnight Resistance*, and *Rastan Saga*) and implements it superbly on computer.

This means five worlds to conquer, in which your hero *Turrican* takes on a weird selection of nasties whilst at the same time negotiating his way around the various platforms and levels. His weapons are collected by picking up symbols on his travels and are very sophisticated – both graphically and in terms of the effect they have in the game play. A delightful multiple shot gun shoots out flak brilliantly whilst the flame thrower, which shoots from the hip, and can be made to rotate its constant stream of flame through 360 degrees, is unparalleled by anything outside of a coin-op in its deadliness.

To match the arcade-sophistication of *Turrican*'s weaponry is a selection of nasties of equal virulence. Some of the end of level guardians are worthy of a special mention – giant scaly monsters that swallow tons of flak before they blow. *Turrican* himself is beautifully animated. Every part of his body seems to move in a muscular way as he travels around the screen.

Another nice touch is a map poster in the box. Some would say that this spoils the fun of mapping the game your self. I don't agree. It is difficult and challenging enough even when you

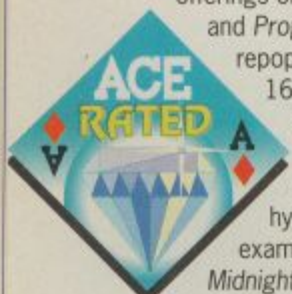

**C64**

*Turrican* is ideally suited to the C64. Its horizontal scrolling, reliance on bright colours and strong sound effects make maximum use of the strengths of the Commodore's older and cheaper machine. *Turrican* proves that the machine that gave you such brilliant arcade game as *Uridium* and *Impossible Mission* has a lot of life left in it yet.

GRAPHICS	9	IQ FACTOR	6	ACE RATING	<b>901</b>
AUDIO	8	FUN FACTOR	8		

**RELEASE BOX**

AMIGA	£24.99dk	OUT NOW
C64/128	£9.99cs £14.99dk	OUT NOW
AMSTRAD	£9.99cs £14.99dk	IMMINENT
SPECTRUM	£9.99cs £14.99dk	IMMINENT

No other versions planned.

**AMIGA**

*Turrican* gets more out of the Amiga than most of the Amiga games to date. Rainbow Arts 'know something' about the Amiga that other programmers in Europe and the US clearly don't. It is almost enough to restore faith that the Amiga is the best games machine money can buy despite rumours of things like FM Towns and Neo Geo's stealing its thunder. From a sound, graphics, and colour-use perspective it is simply head and shoulders above the rest.

GRAPHICS	9	IQ FACTOR	6	ACE RATING	<b>912</b>
AUDIO	9	FUN FACTOR	9		

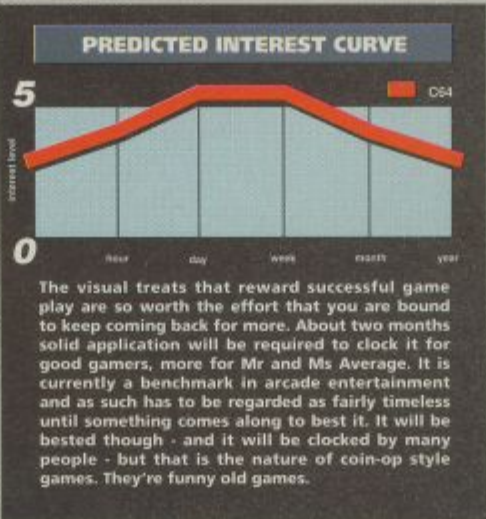

do know where you are and where you are supposed to go. Better still would be a computer generated map that fills in as you travel.

The overall feel of *Turrican* is pure coin-op. The most arcade-like game I have played on a home system since *X-Out* earlier this year and surpassing many similar games for the more advanced console systems.

● Eugene Lacey



*Turrican* encounters something big and nasty, and I'm not talking about his gun!

## FLOOD

ELECTRONIC ARTS/BULLFROG's platform caper narrowly avoids a drowning

After delving into things ethereal with the world wide success of their 'God' simulator, *Populous*, Bullfrog come right back down to earth with something far more temporal in the shape of cutesy platform game, *Flood*.

The hero of *Flood* is a 'slightly overweight wee green Blobbie' called Quiffy. He lives in the caves deep below the ground, feeding on trash left behind by an ancient civilisation. But all is not well in Quiffy's world. The caverns are being taken over by a weird selection of nasties who make life decidedly uncomfortable for our hero. And there is another more serious problem – the caverns are slowly flooding as the 'Taps of Wrath' empty millions of gallons into the underground world that is Quiffy's home. There is only one course open to him – flee the rapidly flooding caverns to the surface where he will be able to breathe.

Quiffy has a task to complete before he can enter the Teleport that will take him to the next cave. He must collect all of the trash that is littering the underground complex. The computer keeps track of the number of items collected – just half a dozen on cave one but up to forty two items by the time he reaches level 39.



*Flood* – something Bullfrog's programmer's dreamed up in the bath?



# LEAP

Although deadly, the nasties are really rather cute. Particularly cuddly are the Psycho Teddies who bounce along the platforms in neat formations. The Bulbous Headed Vong and Sparkling Fungi are not quite so cute though, and they will sap Quiffy's life force, shown by a disappearing brown bar at the top right hand corner of the screen.

Various weapons are available to our hero to help him keep the nasties at bay, but he has to find them first, and this is not always easy on the later levels. The weapons are a delight to use, and graphically excellent. The hand grenades bounce along the ground with a metallic tap, tap, tap, until they blow, sending a gush of flames in both directions. This is a good way of clearing the ground of Snails or Vacuum Gombo's before dashing in to grab the trash. Better still, is the pistol. It looks like an innocuous ladies purse pistol but when you pull its trigger it spits a long streak of fire like a military flame thrower.

All the time Quiffy is trying to fight his way to the surface the taps are slowly filling the caverns with water. Our hero can ease the flow by finding the plungers that are hidden around the screen and sticking them into the taps. But there are also the droplets which, if Quiffy runs into them, will speed up the flood again. Fortunately, there are other useful items to be found in the caverns to help him out.

Quiffy has a unique method of moving. Unlike the hundreds of platform heroes that went before him he is not restricted to simply leaping from ledge to ledge. He can also walk up them vertically or beneath them, or even right along the roofs of the screens. Another nice touch are the teleports. The screen lights up with an explosion of colour as Quiffy is transported from one part of the cavern to another.

As enjoyable as *Flood* is, it lacks depth. It would have benefited from more puzzles requiring several actions to be successful. Good, clean arcade, fun but not really challenging enough for the average ACE reader.

● Eugene Lacey

## PROPHECY

*ELECTRONIC ZOO'S console basher jumps to it*

**P**rophecy is unashamedly a game which borrows all the best design elements of console games and brings them to your computer. If you have played titles like *Ys* on the Sega Master System, and *The Legend of Zelda* on the Nintendo Entertainment System, then you will feel immediately at home with *Prophecy*.

The game play is very simple, but also very appealing. It takes elements of role playing, like strong characterisation of the game hero, a bit of buying and selling, and adversaries to question, and then cross fertilises these with a fairly basic, but addictive, arcade game. The net effect is that of a complex, taxing, arcade adventure with a valuable objective to achieve. No trivial arcade game here.

In *Prophecy* the arcade element is a platform game. Not a pure platform game like *Bubble Bobble*, but an adventure style platform game along the lines of *Super Mario Bros*. The objective is to rescue your family who have been locked in an 'astral plane' by Odin's wicked son, Loki.

The only way Brian, the Viking Child, can rescue his family is to travel the sixteen levels of *Prophecy* and kill Loki's Eight Apprentices of Evil before finally confronting the Dark Lord himself. As Brian travels he must collect money by killing the nasties he encounters. The more money he gets the more power-ups he can buy in the shops he enters as he travels.

Power-up Shops have become a cliché in computer games. About as passe as Next for Men. *Prophecy's* shop lifts itself out of the hackneyed image thanks to its surly sales staff. A gaffed little Gremlin hops around the shelves kicking whatever you fancy into your basket. The owner either nods his head if you have enough money to buy what you fancy or shakes his head if you don't.

The power-ups themselves are a little disappointing. The bombs seem to pop with about as much explosiveness as a flat bottle of Asti. The Fire Sprites and Stuns are a little better but its not until you get into the posh shops where the Potions and Swords are available (to those who are sufficiently flush) that you can really start mixing it with those Apprentices of Evil.

RELEASE BOX		
AMIGA	£24.95dk	IMMINENT
ATARI ST	£24.95dk	OUT NOW
No other versions planned.		

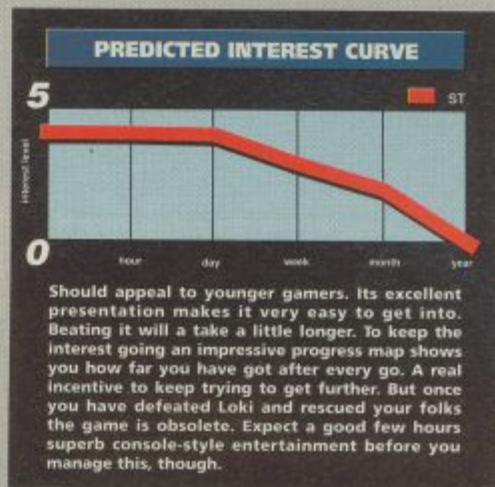

ATARI ST			
GRAPHICS	8	IQ FACTOR	7
AUDIO	7	FUN FACTOR	7
			<b>ACE RATING</b>
			<b>790</b>

The use of the weapons is a little suspect. The space bar moves a cursor along a series of icons representing the various weapons at your disposal. A bit tricky this, particularly when you've got hordes of nasties tracking you while you are attempting to leap on to a moving platform.

*Prophecy* is interesting. Its sixteen levels are varied and pretty to look at, but the game play may not be taxing enough for some. The leaps are a little bit easy, with Brian hanging in the air on occasions as if he was holding on to a string of balloons. That criticism aside, the game does set an absorbing challenge in a most engaging way, and those who do start to play it will find it difficult to put down until they have rescued their folks from that 'Oh-so-hippy' astral plane.

● Eugene Lacey

C64			
Technically excellent, particularly in the sound department. A nice range of sound effects enhance <i>Flood's</i> game play. There are stacks of creatures to discover with a good variety of graphics and visual treats towards the end of the game. Well worth the effort to see them.			
GRAPHICS	8	IQ FACTOR	6
AUDIO	8	FUN FACTOR	7
			<b>ACE RATING</b>
			<b>715</b>

RELEASE BOX		
AMIGA	£19.99dk	OUT NOW
ATARI ST	£19.99dk	OUT NOW
No other versions planned.		

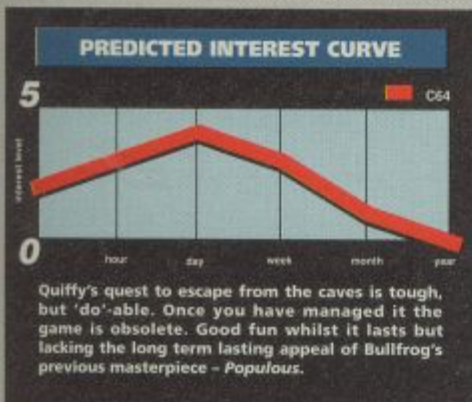

Console style action for the Viking Child from Electronic Arts

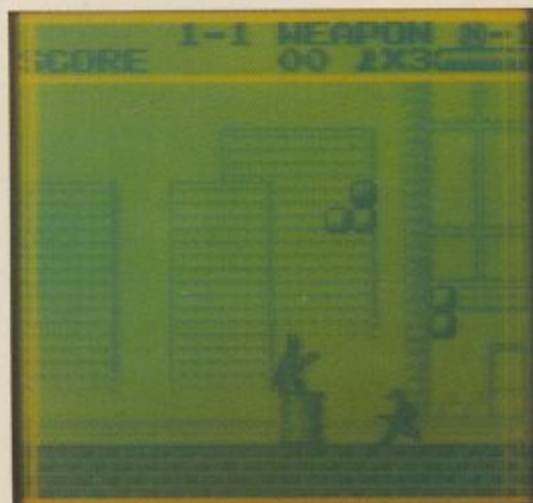

Batman fights it out in the chemical factory with Jack's goons.

# Coming

Our resident Console expert Eugene Lacey gets stuck into the latest games headed for your cartridge port

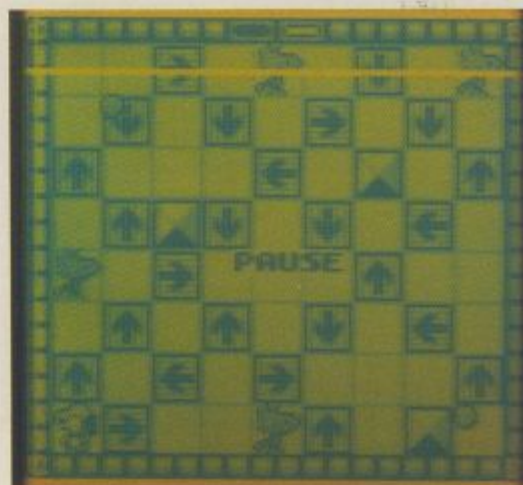

Level sixty two requires a lot of brain work if you are to successfully rescue those Snoopys.

## BATMAN – the Movie

### Gotham City's Gameboy romp

RELEASE BOX			
GAMEBOY	£26.99ct	OUT NOW	
GRAPHICS	6	IQ FACTOR	9
AUDIO	8	FUN FACTOR	8
			<b>ACE RATING</b> <b>890</b>

**PREDICTED INTEREST CURVE**

The toughness of Batman's various levels make it ideal for whiling away those boring hours spent on a regular train or bus journeys. You are going to need a good few rides before you clock.

The caped crusader is no more than the size of a match head on Gameboy's tiny black and white display, but this doesn't stop Suncom from producing a brilliant Gotham City arcade adventure.

The game follows the same basic design as the the bigger Nintendo version, which is just about to be released in the UK. Jack is up to no good in a chemical plant and you have to fight your way past all his henchmen, leaping from platform to platform as you go, before coming face to face with Jack in a life or death scrap. The loser falls into a giant vat of acid. The scrap with Jack is made a hell of a lot easier when you finally realise that you have to shoot Jack in the head to weaken him.

But even if you defeat Jack this is not the end of the wily old Joker. The chemical plant is the first of several progressively difficult levels. After the chemical plant comes Gotham City, two levels of Museum, and the Bat Wing level where you are at the controls of the Bat plane. This is a

mean, scrolling shoot 'em up with the Joker lobbing bombs, planes, and missiles at you.

Although the variety of levels makes Batman a varied and exciting game it is in the Mario Land-style game play that the game really excels. Just as in Mario there are secret weapons, energy pills, and other items to be found by shooting out the blocks that are scattered around the levels. The best of these are the three Batarans that the caped crusader can swing around his head, creating an impenetrable protective force field as he explores the platforms.

Recent reports from the US tell of a quantum leap in the quality of new Gameboy titles. Batman is one of the first of this new breed. An unputdownable and addictive arcade adventure.

The limitations of Gameboy graphics created by its tiny black and white display have been a blessing in disguise. It has forced game designers to concentrate on playability, ensuring that there are sufficient entertaining and addictive hooks to keep the player committed.

A typical example of this is the new game, Snoopy. A series of progressively more difficult maze puzzles in which you have to rescue the four Snoopys whilst avoiding the nasties. Blocks can be shoved around the screen to block off the nasties or to gain access to the areas where the Snoopys are trapped.

Lots of secrets are hidden behind some of the blocks, like a clock for extra time, teleports for getting around the screen and many more.

The basic aim is to get to the highest screen possible. There are several hundred of these so be prepared to invest a considerable amount of time if you want to get onto a really high level.

RELEASE BOX			
GAMEBOY	£26.99ct	OUT NOW	
GRAPHICS	6	IQ FACTOR	7
AUDIO	6	FUN FACTOR	8
			<b>ACE RATING</b> <b>750</b>

**PREDICTED INTEREST CURVE**

Snoopy is a real brain teaser and will appeal to people who see their Gameboy as a crossword alternative. A word of warning though; its puzzles are not for those who enjoy more traditional, arcade-style maze games. Snoopy's superficial similarity to Pacman could well be misleading. Much more of a puzzler than a race and chase game.

A useful secret code number system enables you to begin the game where you left off, as long as you can remember the code that is.

The fun part of Snoopy is in working out the puzzles. The best route to take to rescue the Snoopys in as quick a time as possible whilst at the same time avoiding the nasties. Snoopy is a test of brain power as well as reflexes, ideal for a long car or train journey.

## SNOOPY

### How much is that doggy in the Gameboy?

# for Consoles

## TETRIS

The Sega Megadrive dances to a Russian tune

Oh the difference colour makes. There has been a lot of *Tetris* playing around the ACE office of late, mostly on Gameboy and Macintosh. Both of these versions are excellent but they do have the disadvantage of being brought to you in black-and-white-o-vision.

Megadrive *Tetris* is a full colour version just as were the earlier Amiga and ST incarnations. But it offers more than just bright colours in terms of game play enhancements.

You can choose the level you wish to compete on which has the important effect of determining the speed at which the shapes fall groundwards. For the uninitiated *Tetris* is a simple game in which you have to make lines by fitting together shapes. When a complete solid line is created it will then disappear earning you bonus points. If you fail to make solid lines then pretty soon the whole play area will fill and no more shapes can fall, thus losing you the game.

It sounds simple and it is but it is also mad-deningly addictive. The benefit of colour is that you can earn extra bonus points by making up solid lines of the same colour. You can do this in the black and white versions by going for the pieces with similar shading but it is much more difficult to do and hurts your eyes after a while.

Gameplay is very smooth and enables very swift manipulation of the shapes. I particularly like the way the Megadrive version enables you

to shuffle a shape along a solid object. If you flick the joypad really quickly you can get a shape to move up to two places along a solid surface, a useful trick if you want to get out of tight spots and take a quantum leap into the super league skills bracket of *Tetris* play.

Sound effects are also excellent. That mad-deningly catchy Russian folk tune that you can't help humming along to plays throughout but does not cancel out other sound effects, like the good, solid thumps as the pieces fall into place.

*Tetris* is a masterpiece and no system should be without a version. The Megadrive version is one of the best I've seen, certainly out performing Amiga and ST versions. Its great strength lies in its timeless appeal. You are always going to feel in the mood for a spot of *Tetris* every so often, so the cartridge will earn its keep perhaps more than any other game you might buy.

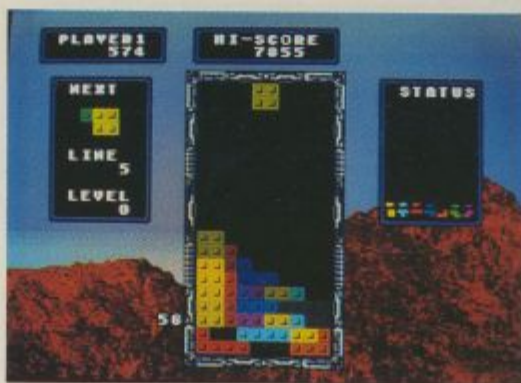

Megadrive *Tetris* - the Russian masterpiece has never sounded or looked better.

**RELEASE BOX**

**MEGADRIVE** £39.99ct OUT NOW

GRAPHICS	7	IQ FACTOR	9	<b>ACE RATING</b> <b>890</b>
AUDIO	9	FUN FACTOR	9	

**PREDICTED INTEREST CURVE**

Although one of the simplest games you could possibly imagine the scope for applying strategy and technique is boundless. *Tetris* is so addictive and enjoyable that it is difficult to think of a game with more long term lasting appeal.

The most important of these are the Batarangs. These can be made to swirl around Batman's head and he can also lob them at Jack's henchmen.

Of course the caped crusader never relies too heavily on weaponry. He has two good fists and uses them in plenty of hand to hand scrapping with the Joker's baddies.

The graphics and sound are very atmospheric creating a definite feel of the movie even if the plot of the same is pretty much disregarded.

A superb opening scene shows the Batmobile zooming off and tells you what you have to do in scrolling text and pictures.

Batfans will love this. It is more of a platform beat 'em up than the arcade adventure that you might expect. But fast and furious and not for the beginner.

## BATMAN

Holy Nintendo, the Caped Crusader is back

Lets get one thing straight right away. This is not the same *Batman - The Movie* game that was produced last year for home computers by Ocean. This is an entirely new game based on the blockbusting film, designed especially for the Nintendo machines (Gameboy and Entertainment System) by Sunsoft.

Your aim is to pursue the Joker through five levels of play in and around Gotham City. The look and feel of the early stages put you in mind of *Super Mario Brothers*. There is a lot of platform work to be carried out, with very precise jumps required in some stages. There are also hidden power-ups and life-boosters to be discovered.



**RELEASE BOX**

**NES** £29.95ct OUT NOW

GRAPHICS	8	IQ FACTOR	7	<b>ACE RATING</b> <b>890</b>
AUDIO	8	FUN FACTOR	8	

**PREDICTED INTEREST CURVE**

The game play is taxing and pretty to look at. However, the whole appeal of the game is highly reliant on being a Batman fan. You are unlikely to regard the game as a classic in its own right if you are not a Batfan. That said, it is tough and will take a lot of playing to clock it. Once its done though, thats it.

# POWER DRIFT

## Sega's hot rod racer revs up the Engine

**P**ower Drift has always drawn a strong response from gamers. They either love it or they hate it. In the arcades it was a modest success without ever rivalling the mega-success of Sega's other brilliant racer, *Out Run*.

The home computer versions from Activision did little to win new fans to the hot rod racing game. Now this PC Engine version takes up the mantle.

At first glance you think "wow" this really is just like the arcade game but pretty soon the limitations of this version become apparent. The basic problem is the simple simulation of speed of motion in 3D. It just doesn't hack it. Your speedo may say you are doing over a ton but it just doesn't feel like.

The basic aim of *Power Drift* is to win races against other computer controlled cars. Your hot rod is built like a sleek dart with giant wheels at the back and small ones at the front. Moving through the gears enables you to accelerate at great speed, pulling ahead of your opponents.



PC Engine *Power Drift* is better than the other versions but still fails to set the world alight.

There are nine courses of different difficulty levels and with nice changes in scenery, from desert to snowy mountain peaks. Best of all are the bonus levels if you finish first in enough races. These enable you to have a ride on the *Super Hang on* bike or the *Afterburner* jet, much better than the usual digitised screen in which a couple of bikini clad bimbos place a laurel leaf garland around your neck.

The best part of *Power Drift* is the presentation and game select screens. These are identical to the coin-op and very impressive. It is just a shame that the game itself does not provide the thrills and spills of the arcade machine.

**RELEASE BOX**

PC ENGINE £34.99ct OUT NOW

GRAPHICS	6	IQ FACTOR	6	ACE RATING	<b>604</b>
AUDIO	6	FUN FACTOR	6		

**PREDICTED INTEREST CURVE**

You have to be a real *Power Drift* fanatic to go for this one. It really is a fairly average conversion. There are better racers in the Engine range, *Chase HQ* and *Victory Run* for example. Both of these are likely to provide a racing game of much longer lasting appeal.

# THUNDERFORCE III

## The Sega Megadrive's favourite blaster gets an upgrade

**A**ll new computers and games consoles need a benchmark shoot 'em up so that gamers can judge what they are capable of. In the case of the PC Engine it was *R-Type* and much later *Gunhed*. The Megadrive had *Thunderforce*. Its bright colours, superb sound and frenetic shoot 'em up action were strong evidence that the Megadrive was every bit the equal of the PC Engine.

Now *Thunderforce III* improves on the original game with even better graphics and sound, and several new levels to battle your way through.

At the start of the game you view the galaxy from the bridge of the ship. This is where you receive your mission briefing. You are told the name of the planet to head for and the end of level guardian you have to attack when you get

there, including its weak spot which is very useful information because when you first encounter them it appears that they don't have any weaknesses whatsoever.

*Thunderforce III* is pretty thin on plot. You know the script anyway. Pick up those power ups and blast anything that moves.

The good thing about *Thunderforce* is that it requires good flight skills as well as a quick finger on the fire button. Use of the power ups also requires intelligence, in as much as some of them are appropriate in certain situations and this is for you to work out.

*Thunderforce* ups the stakes in the console wars. For my money it is a better shoot 'em up than anything I have seen on any other system. It is also better than many coin-ops I have played. Well worth a gander.

# BARUMBA

## PC Engine shoot 'em ups go cute

**RELEASE BOX**

PC ENGINE £39.99ct OUT NOW

GRAPHICS	8	IQ FACTOR	7	ACE RATING	<b>835</b>
AUDIO	7	FUN FACTOR	8		

**PREDICTED INTEREST CURVE**

*Barumba* follows the tradition of games that are cute but tough. Its cavernous levels are fun to explore and using its cartoon-style weapons is also entertaining. Not in the PC Engine super game league by any stretch but a nice little game just the same.

**RELEASE BOX**

MEGADRIVE £39.99ct OUT NOW

GRAPHICS	9	IQ FACTOR	6	ACE RATING	<b>911</b>
AUDIO	9	FUN FACTOR	9		

**PREDICTED INTEREST CURVE**

*Thunderforce III* is a very taxing shoot 'em up. Even really good gamers are going to need to put in the hours to clock this one. Superb graphics and sound make it one of the very best games for the Megadrive. Should more than earn its keep in terms of getting plugged in on a regular basis.



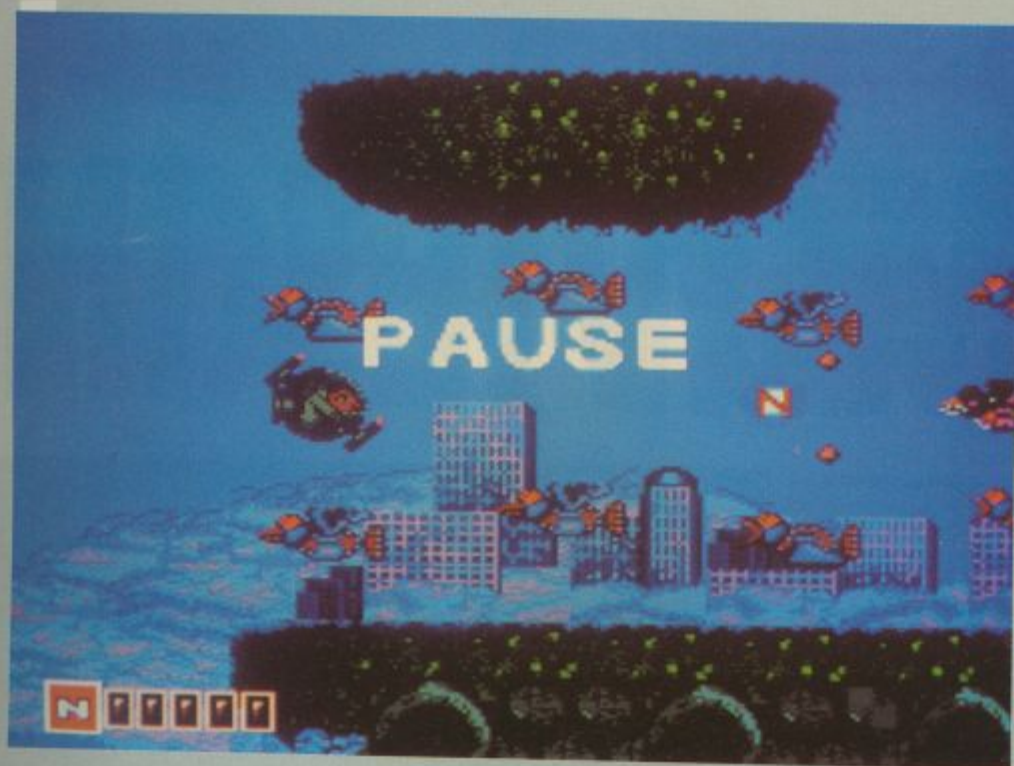

Barumba has several cute power ups that are excellent fun to use.

**B**arumba takes its inspiration from the cute school of Japanese shoot 'em ups. It owes more to the likes of *Mr Heli* than to the mean and moody *R-Type* and *Dragons Breed* school.

You are at the controls of a strange helicopter-like machine on a mission to seek out and destroy a mad Professor who is threatening the world. The various levels are cavernous, taking you below ground as well as into the sky.

The challenge of *Barumba* is as much to find your way around the huge and complex play area as it is to blast the nasties in the employ of the mad Prof.

Power ups are of a similar cute ilk. Particularly neat are the two bubbles that can be made to spin off towards your enemy. A whole range of multi-directional weapons are available to power-up with.

The main nasties are also cute. The flying dragons at the end of the first level are green and scaly but they still somehow manage to look like an inflatable toy that a child might play with in the bath.

Despite its cuteness, *Barumba* packs a mean challenge. Lovers of cute will not want to miss it.

RELEASE BOX		
SEGA	£39.95ct	OUT NOW

GRAPHICS	8	IQ FACTOR	9	ACE RATING <b>929</b>
AUDIO	8	FUN FACTOR	9	



Good RPG's always score highly in the longevity stakes and this Sega version of the excellent *Ultima* game is no exception. There are so many commands for you to master, territories for you to explore, spells to cast, people to talk to, creatures to fight, and mysteries to solve that it has the potential to keep you hooked for months. Many *Ultima* players find it doesn't last quite that long. But this is generally because they find it so gripping that they play it virtually around the clock until they have solved it. Enough said.



# ULTIMA IV – The Quest of the Avatar

## Lord British casts his unique spell on the Sega Master System

**T**he *Ultima* series of role playing games are America's favourite RPG's. Their eccentric designer, the self styled Lord British, has become fabulously wealthy on the proceeds of his games and has invested some of his cash in building a fabulous castle-style home complete with secret passages and its own observatory.

The attraction of the games rests in their complexity, attention to detail, and the variety of commands at the players finger tips. They offer you so much more than the average Search,

Talk, and Move commands. The impressive achievement in the Sega version is that it has lost none of its RPG sophistication through the loss of a keyboard. If anything the keypad makes the game quicker and easier to use.

*The Quest of the Avatar* sets the adventurer the mystical task of searching the land for, in the words of Lord British, "a new standard, a new vision of life" and guidance from the "Age of Darkness into the Age of Light".

There are "Eight Virtues of the Avatar" and the adventurer must become well schooled in all of them to attain the true enlightened state of the Avatar.

The path of enlightenment lies in conversation as well as exploration. The traveller must talk to all people in all the towns, villages, and Hamlets in the land of Brittania. He who finds the Avatar will become truly enlightened.

The early history of Brittania is provided in the excellent manual that accompanies the game. This is essential reading if you want to

experience the rich characterisation of the characters and also to learn the history of the land as played out in *Ultima I, II, and III*. You do not need to know this to play the game. *Ultima IV* is the first of the series to appear on Sega and stands alone in its own right. You will get more out of it if you do read it though, especially if you have not played an RPG game before.

The land of Brittania is viewed from above with the terrain scrolling in four directions in a window to the left of the screen. The window on the right opens up to enable you to select the actions you want to implement. These are many and varied, and divide into various subheadings depending on which main heading you select. Spell, for example, leads into a list of ingredients that you will need to make the spell that you wish to cast it. Full instructions on casting spells and other magic is provided in the manual.

As with all RPG games, the 'Status' panel needs to be visited regularly to check your health and strength, find out what you are carrying, and see if your weaponry is sufficient to enter into combat with a certain enemy.

There is so much depth to *Ultima IV* that it is difficult to get all of it across in short review. If you have never had the inclination to try one, then there has never been a better incentive. There are a lot of games in this style for consoles, particularly in Japan. The *Ultima* series are the originals and the best. This is good enough to last you right through the Summer holidays and into the Winter as well, by which time, hopefully, Lord British's minions will have finished work on *Ultima V*.



Hemmed in by water. You need some good advice.

# MOVIES IN



**RISE OF THE DRAGON** by Dynamix. This futuristic cyberpunk private-eye adventure is a totally new type of interactive game, a product of Dynamix's new GDS (Game Development System).

**KING'S QUEST V** by Sierra On-Line. With over 10Mb of game data, chapter five in the King's Quest saga is one of the biggest computer games ever produced. King's Quest will be the first game to employ Sierra's new 'cinemagraphic' technology utilising sophisticated Hollywood animation techniques. It is scheduled for release in autumn on PC, Amiga, ST, Macintosh and PC CD-ROM.

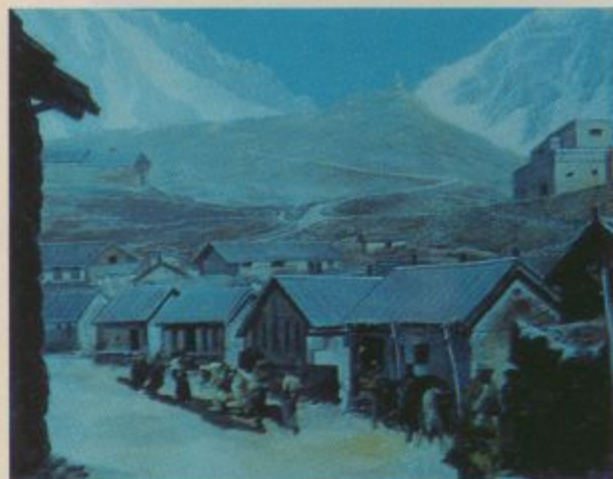

**HEART OF CHINA** by Dynamix. This action adventure is set in the 1930's at the beginning of the Chinese revolution. You play 'Lucky' Jake Masters, hired to rescue Kate Lomax, the kidnapped daughter of a wealthy American investor.



**HEART OF CHINA.** The game features a no-typing 'point and click' interface, 256-colour VGA graphics, cinematic cutaways, 'meanwhile' screens, and a viewpoint that switches between the three major characters.



**HEART OF CHINA.** Kate Lomax is held by the leader of a war-torn feudal state. Her life now rests in your hands. During the game you travel through such exotic locations as China, Hong Kong, Kathmandu, Istanbul and Paris.



**RISE OF THE DRAGON.** This game has the feel and atmosphere of the classic Ridley Scott sci-fi movie, Blade Runner, coupled with the interaction of an involved game with an advanced - but simple to use - player interface. When it's finished it could be the game of the year!

**RISE OF THE DRAGON.** The animated dancer in this sleazy nightclub scene was originally a girlie working for Dynamix - before her dancing routines were digitised and 'retouched' into sprites. All the backgrounds for these Sierra On-Line/Dynamix games are digitised from airbrushed paintings - producing stunning visuals in the games.



# IN YOUR MICRO

Sierra On-Line and Dynamix have joined forces to create revolutionary

Interactive Entertainment titles. Rik Haynes previews their incredible interactive CD-ROM movies...



**SPACE QUEST IV** by Sierra On-Line. Subtitled *Roger Wilco and the Time Rippers*, Space Quest IV features 256-colour VGA graphics and the first scrolling screens ever seen in a Sierra adventure. It will be available this autumn initially for PC in both floppy and CD-ROM formats. Versions for the Amiga, ST and Macintosh will follow soon afterward.

Although these Sierra On-Line and Dynamix CD-ROM games will be initially released only on PC CD-ROM format, the innovative US software developers aren't ruling out versions for the Commodore Amiga CDTV, Macintosh CD-ROM, Fujitsu FM Towns and NEC PC Engine/TurboGrafx CD-ROM machines



**HEART OF CHINA.** In your mission to reunite Miss Lomax with her father, you must enlist the aid of a street-wise ninja, Chi. You then set out to storm the kidnapper's fortress and rescue the heroine. Gameplay involves character interaction, puzzle solving and action simulations.

*"True interactive 'film-like' entertainment is within the grasp of every computer owner."*

Sierra On-Line and Dynamix

**RISE OF THE DRAGON.** "As a 21st century private investigator, you wander through the city gripped by evil as you attempt to unravel the darkest, most deadly mystery of your career." Every scene and sequence is portrayed as you would see it if you were actually there.

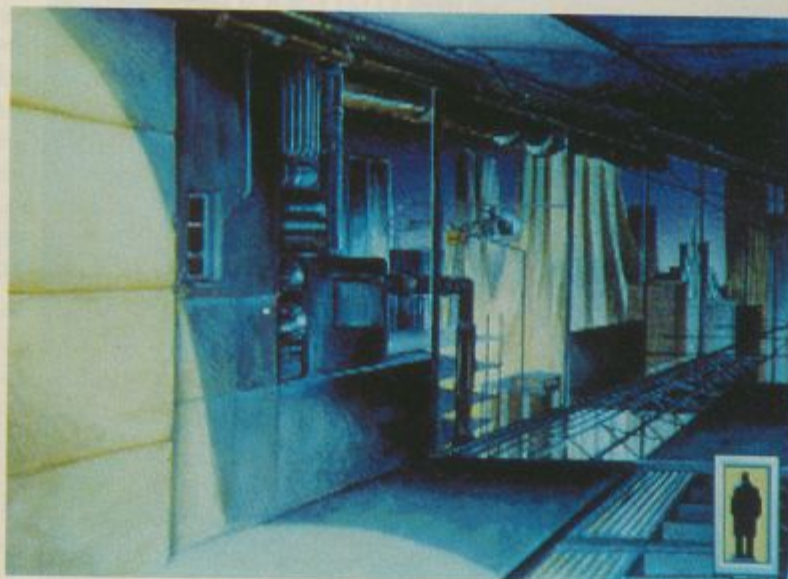

**MIXED-UP MOTHER GOOSE CD-ROM** by Sierra On-Line. The new range of Sierra and Dynamix games feature breathtaking visuals - some of the best graphics ever seen in computer games. With almost 30 years of motion picture experience, Bill Davis - Sierra's Vice President of Creative Development - is exploring the limits of computer graphics technology. Davis has assembled a staff of over 30 illustrators, animators and background painters from around the world.



**MIXED-UP MOTHER GOOSE CD-ROM** contains several language soundtracks allowing you to hear the game's characters speak and sing in English, Japanese or Spanish. The game is due for release on two compact discs this autumn for PC CD-ROM machines.

**MIXED-UP MOTHER GOOSE CD-ROM** is an enhanced version of the original Sierra game with 256-colour VGA backgrounds and animated characters, stereo soundtrack, and digitised speaking and singing voices.



# dates up

Tony Dillon  
keeps you up  
to date with  
new releases  
of old  
games...

## C64

### ATOMIX

Thalion; £24.95 dk; Amiga version reviewed issue 22; ACE rating 680

You know what they say: the best ideas are simple. That's not to say that simple ideas are the best. But the question you're all asking is where does *Atomix* fit in? Somewhere between the two. Along the lines of a children's slide puzzle where you rearrange the numbers, *Atomix* has you moving molecules around putting together complex structures. It plays well and looks fine on all machines, even though for a game like this you don't really need amazing graphics. It's hard enough to last ages and addictive enough to keep you playing. A goody.

ACE RATING 815

### VOYAGER

Ocean; £24.99

The game with the cover that inspired millions of worried parents and stuffy guardians of public morals to wonder "Is he reading what I think he's reading?" (A tacky girlie mag for those who missed out on this one). Well, what do you expect? Luke Snayles has been sat out in deep space for 50 years, and it's time to come home. The problem is that home is being invaded by aliens, and Snayles is a little annoyed about that. So he does what anyone would do, he sets out to annihilate them. Full of fast, smooth vectors, *Voyager* looks uncannily like the first level of *Psygnosis' Infestation*. The difference here is that this doesn't get any different. After half an hour of travelling around the same grey landscape, I can only admit to being bored stupid. Looks good, shame about the game.

ACE RATING 610



## PC

### SIM CITY

Domark; £24.99; Amiga Version reviewed Issue 24; ACE Rating 945



One of the greatest games ever written has finally made its way across the the ST, and for the first time ever, I'm glad it's a port. Begin with an area of barren land and create your very own population, or start with an established city (such as San Francisco) and see the effects of an earthquake, a nuclear meltdown or even an attack from Godzilla. The graphics are identical to the Amiga and PC, and it plays exactly the same. DO NOT MISS!

ACE RATING 915



## AMIGA

## KLAX

Domark; £24.95 dk; ST Version reviewed Issue 32; ACE Rating 895

*Klax* is one of the few puzzle games that could ever hold a candle to *Tetris*. The only real problem with the Amiga version is that it is almost identical to the ST version, bar the sound, which is full of very long, very clear samples. Playability wise the game is difficult, brain numbingly so. The speed between blocks is far too fast, making planning your stacks impossible, especially when you have to create diagonals. A tough yet enjoyable puzzler.

ACE RATING 830

## LEAVIN' TERAMIS

Thalion; Price £24.95dk; ST Version reviewed Issue 32; ACE Rating 810

*Leavin' Teramis* has absolutely nothing new to offer at all. A straightforward vertical scroller with the same old bubble guns that rise out of the ground, the same old spaceships that loop around and the same old collectible weapons. Even the sight of a clockwork Pacman could do nothing to add originality. It's fun to play, mind, just not very original. Not worth buying if you have any decent SEU's in your collection.

ACE RATING 610

## PIRATES

Microprose; £24.95; C64 Version reviewed Issue 1; ACE Rating 734

With a heave, and a ho, we set sail for blighty, oh matey! Crows nest, ships cat etc. and various other sea-faring swashbuckling phrases. *Pirates*, one of the best games Microprose have ever done has now appeared on the Amiga, and it's as amazing as ever. The game is basically the same, you as Captain of a pirate ship,

have to kill as many people and get as much gold as possible. There's even a bit of sword fighting involved, if that's your thing. The upgraded graphics and sound are incredible, and it's basically a superb product. What more can I say?

ACE RATING 910



## ST

## BLOOD MONEY

Psygnosis; £9.99 cs; £14.99 dk; Amiga version reviewed Issue 22 ACE Rating 732

On 16-bit machines *Blood Money* had almost everything a perfect arcade game needed – attractive sprites and backdrops, smooth scrolling and animation, well hyped by a young and hungry company and tons of aliens for you to blast. The real problem with 16 bit *Blood Money* was that it was just irrepressibly dull and far too hard. The C64 version, interestingly, solves some of this problem by being very easy. But, the game still remains amazingly uninspiring, and it was only sheer hard work that kept me playing. A sizzling, red hot duffer.

ACE RATING 385

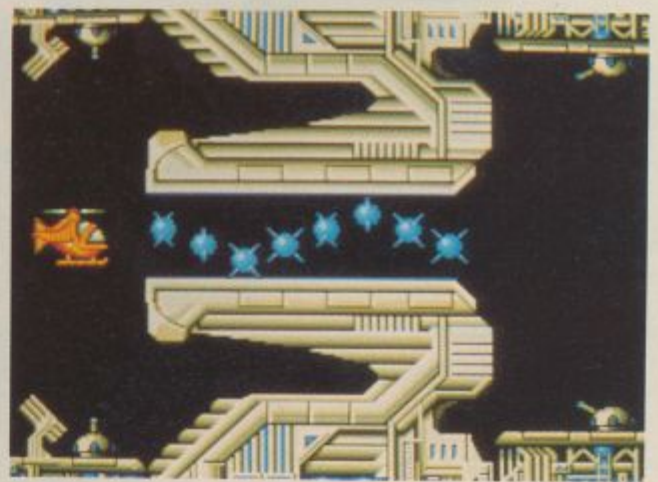
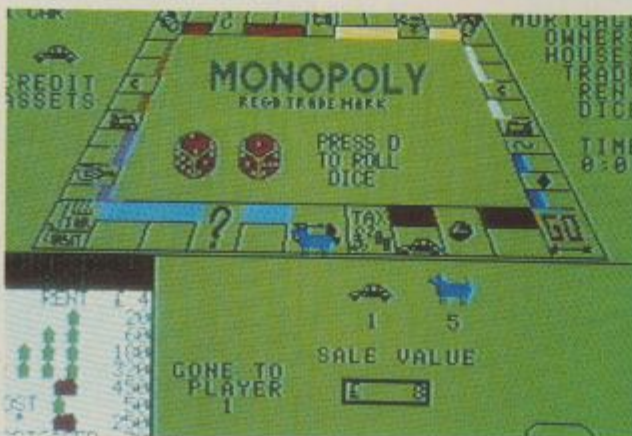

## MIND-STRETCHERS

Virgin; £19.99 cs/dk

Three classic board games in one happy package! *Mind-Stretchers* gives you the chance to play *Scrabble* ("the game of words"), *Monopoly* ("the game of money") and *Cluedo* ("the game of murder") against your friends or your computer. The games play identical to the board game in every respect, so the only real advantages in playing on a computer are (a) you can't lose any of the pieces and (b) you always have somebody to play against, even if the satisfaction of beating the computer doesn't come close to that of beating a human opponent. Worth getting hold of for a trip down memory lane.

ACE Rating 720

## AMSTRAD

## CASTLE MASTER

The only real differences between the Amstrad version and the other formats, bar the Spectrum, is that it has less colours and is a lot slower. The controls are incredibly sluggish and the frame rate matches. This is definitely a product for either masochists or someone of great patience.

ACE RATING 680

## SUPER GRID RUNNER

Llamasoft; £10.95dk

Jeff Minter has always struck me as nothing more than a slight eccentric with a fixation for sheep-like animals, using his strange obsessions to create would could be seen as unusual games. This, however, does not mean that they are any good. *Super Grid Runner* is conversion of a very old C64 game looks just that – very old and very dated. The Mouse only control I found to be quite usable but very limited. Aliens coming on in small single waves accompanied by very little in the way of playability left me with a feeling of "What a waste of time". Colourful, fast and boring.

ACE RATING 410



OPERATION WOLF £29.99

# SEGA®

FROM

*Virgin*



CHASE HQ £29.99

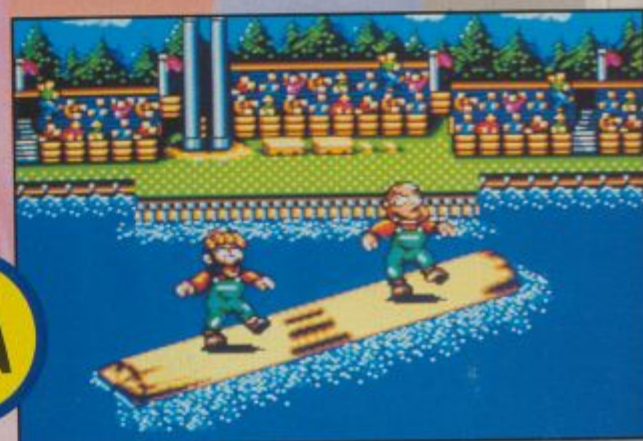

WORLD GAMES £24.99

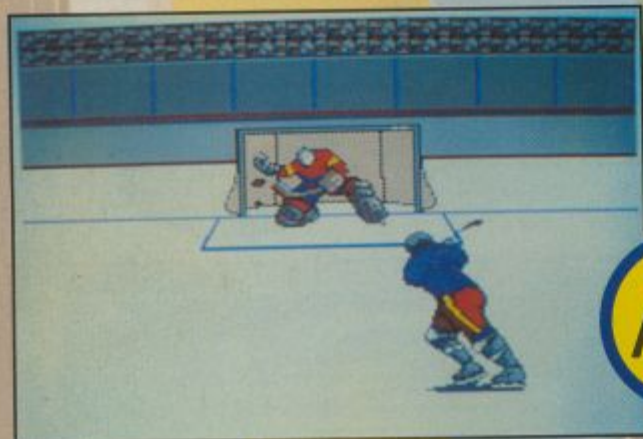

SLAP SHOT £29.99



RC GRAND PRIX £29.99



ASSAULT CITY £29.99



BATTLE OUTRUN £29.99

®

# WAAAH!

IT'S THE

# SEGA®

## SONG COMP!

WIN 2 DAYS OF FREE STUDIO TIME AT THE FAMOUS VIRGIN 24 TRACK LONDON STUDIO - TOWNHOUSE 3!

ALL YOU HAVE TO DO is write a song about how cool and groovy the Sega Console is, bung it on a cassette (quality of recording is NOT important but we'll be listening for lyrics and content!!). Send it in to Virgin Mastertronic 2-4 Vernon Yard, 119 Portobello Road, London W11 2DX. Please also include a photo and something about yourself. (Send a *suitable* S.A.E. if you want your pix and tape back!).

THE WINNING BAND/ARTIST will record their 'Sega Song' plus one track of their own material. The 'Sega Song' will be released on Flexi-Disc through a top computer magazine! You get a professionally recorded 1/4 inch mixed copymaster and 25 free demo-cassettes to take away, (rice extra!).

CLOSING DATE is August 20th 1990 and Judges decision will be final! Don't forget that Sega is pronounced 'SEYGA'. More info is available from Virgin on 071 727 8070. Ask for the Beast!

*ALL STYLES of music are welcome. This comp is NOT open to any employee or associate of Virgin Mastertronic so there!*

GO ON...DO YOURSELF A FAVOUR!

FROM

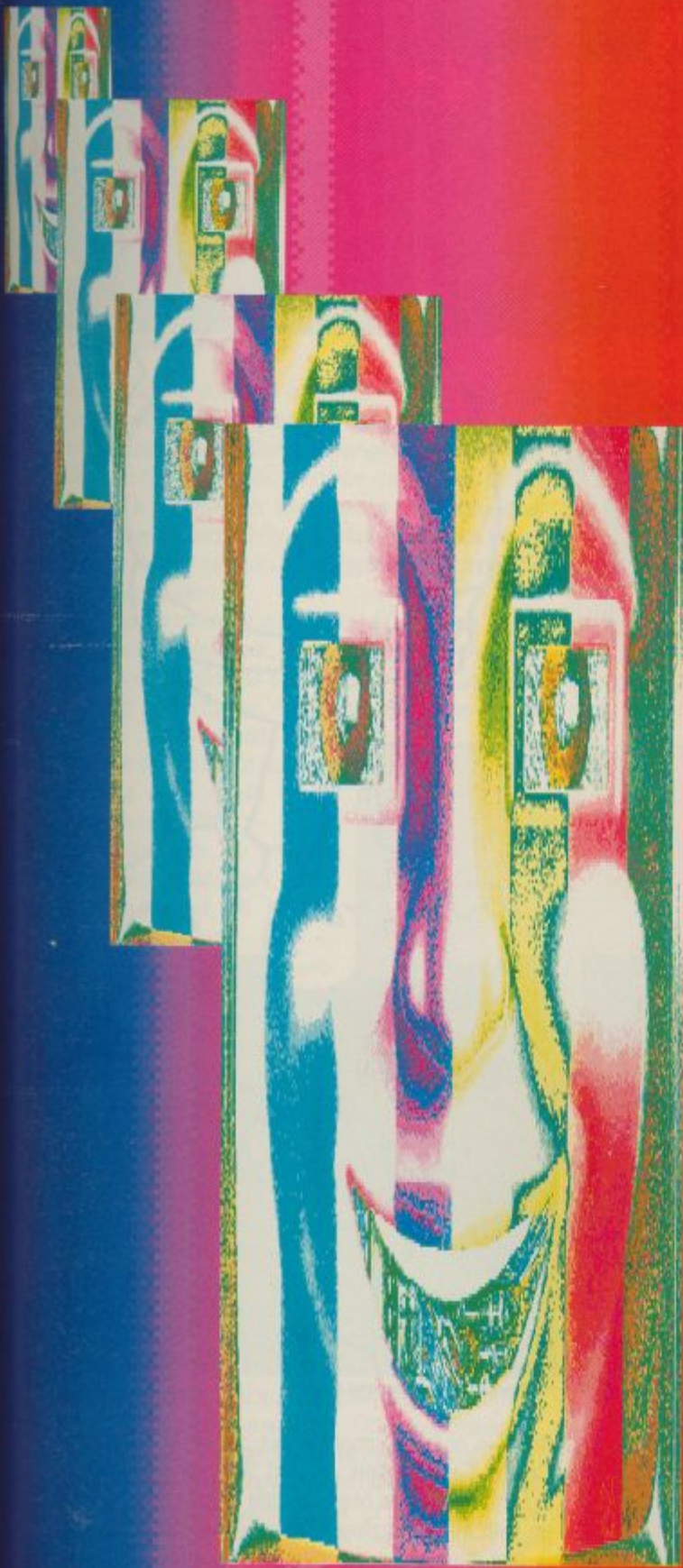

9

99

.99

# Too Cute to Handle

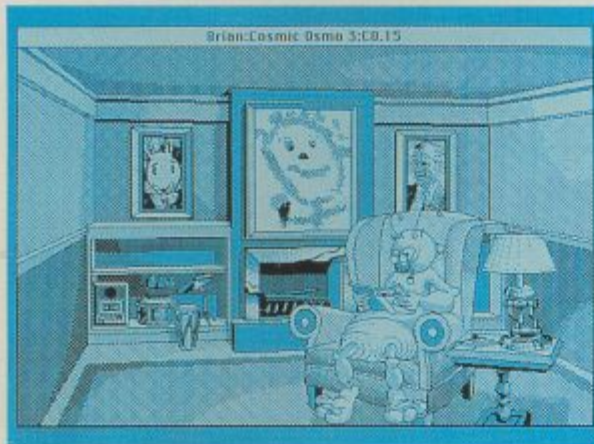

Cosmic Osmo - proving that cute games are not only for kids. You need a powerful Apple Macintosh with a meaty hard disk to support the game. Individual characters that are important but the style of characterisation itself - which transcends national barriers

Just how much cuteness can you stand in a computer game? Cuddly Eugene Lacey confronts the classic cute culprits

Since Pacman begat Ms Pacman and Q'bert stuck his long red snout into a Gottlieb arcade cabinet in early 1981 computer games have been obsessed with cute.

This penchant for cuteness has never been properly explained. One obvious reason may be that computer games are, in the majority of cases, designed by adults to be played by children - or the young at heart. It is therefore assumed that cutesy teddy bears, rodents, animals, and cartoon characters will go down best.

Not surprisingly, it is on the consoles that cute games reign supreme, thanks to a generally younger age profile amongst their owners. Nintendo have become the IBM of video games on the back of one cute video game character - Mario. The Super Mario series have sold mountains of cartridges all over the world. Consoles have always majored on cute games. The Colecovision starred the Smurfs, the Atari VCS had Pitfall Harry, the Sega has Alex Kid, and the Nintendo has the irrepressible Mario - now on game four, and selling upwards of five million each episode.

But what the child-targetting theory doesn't explain about cute is the universal popularity of the games on big home computers, and in the arcades, where games players, in general, are over sixteen. It is interesting to note the universal popularity of cute games amongst all ages.

A major reason for this has to do with the nature of the games. Cute does not necessarily mean easy. Although they may look like a Saturday morning cartoon - or at least aspire to that style of presentation -

## CUTEST GAMES OF ALL TIME

1 Cosmic Osmo	Cyan
2 Pacman	Gottlieb
3 Ms Pacman	Williams
4 Little Computer People	Activision
5 Pengo	Sega
6 Super Mario Brothers	Nintendo
7 Alex Kid	Sega
8 Q'bert	Gottlieb
9 Frogger	Sega
10 Monty Mole Series	Gremlin
11 Garfield	The Edge
12 Hungry Horace Series	Melbourne House
13 Road Runner	US Gold

## CUTE BUT NAFF

1 Postman Pat	Again Again
2 Ah Diddums	Imagine
3 Who Framed Roger Rabbit	Buena Vista
4 Pink Panther	Magic Bytes
5 Tom and Jerry	Magic Bytes

## MOST PLAYABLE CUTE COIN-OPS

1 Bubble Bobble	Taito
2 Rainbow Islands	Taito
3 New Zealand Story	Taito
4 Crystal Castles	Atari
5 Pacman	Namco



Pacland by Grandslam and Namco

there is nothing simple about Super Mario Brothers, Crystal Castles, New Zealand Story or Bubble Bobble. In fact, one of the reasons cute games so often come up with mind boggling difficult video game challenges is that they allow the designer to start with a blank sheet. When a group of Sega designers were given a brief to design a game about a frog they were forced to think laterally. The end result was the monster hit Frogger - a game with totally original game play.

BurgerTime was another game that scored highly in the originality stakes. The idea was to assemble hamburgers by dropping various items on to a bread roll base - first the meat pattie, then the lettuce, onions, tomato sauce and pickled cucumbers until you were ready for the top slice of the bun, whilst all the time dodging the nasties in the form of mustard and mad sausages. The home computer software houses were



Rainbow Islands by Taito and Ocean

quick to spot the potential of *BurgerTime*. Ocean, for instance, had a clone called *Mr Wimpy* – just one of dozens of copies of the DataEast original.

Many of the best cute coin-ops came out of the early 1980's. *Pacman*, for example, became a national hero in America with fluffy *Pacman* dolls, clockwork ghosts and even a cartoon series spinning off from the cult video game hero.

*Q'bert* was another original cute hit. The long snouted alien had to hop from square to square changing the colours of the tiles as he landed on them until they were all the same colour. A hissing snake was hot on his heels and would take *Q'bert's* life if he caught up with him. Losing a life would cause *Q'bert* to swear (#@\$!\*) – immediately winning him an army of foul mouthed supporters. Like *BurgerTime*, almost all of the home software houses were in for a slice of *Q'bert* and produced thinly disguised clones.

The cutest game of them all was Sega's *Pengo*. Your penguin had to rearrange giant blocks of ice by shoving them around with his beak – squashing the 'Sno Bees' that were in hot pursuit.

Sometimes the freedom of 'cute' goes straight to the designers heads and leads them well over the top. *Joust*, for example, is the all time *Sergeant Pepper* of video games. When gamers saw the knights flying around in space on giant ostriches the word went out around the arcades – what were those designers drinking – or smoking?

Jeff Minter took spaced out themes even further with many of his cuddly creations. Titles like *Sheep in Space* and *Mutant Llamas Battle at the Edge of Time* pushed 'cute' to hilariously absurd limits. But not all cute games had the same spark of originality. The genre has had its share of 'me to's' with a particular obsession for platform capers. In the mid-eighties everyone had to have one. Mirrorsoft had *Dynamite Dan*, Firebird had *Booty*, Bug Byte had *Manic Miner*, Bubble Bus had *Star Quake* and, best of all, Gremlin had *Monty Mole*.

What all these platform games had in common was a 'cute' hero with whom the gamer could identify as he struggled to manoeuvre the character around the ever more intricate platforms and ladders. The software houses worked on the characterisation of these characters in their advertisements and packaging – as well as in the computer graphics of the characters themselves.



Rick Dangerous by Core Design and Microprose

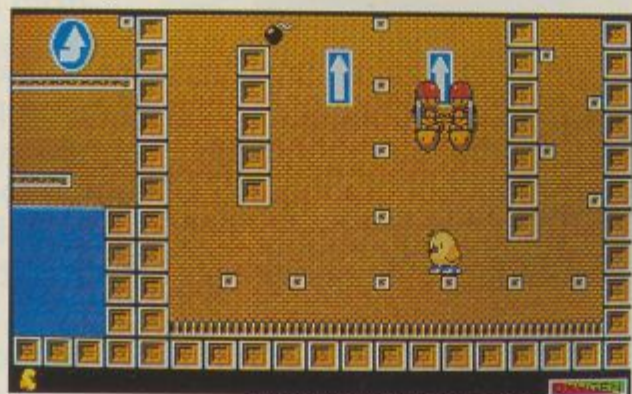

New Zealand Story by Taito and Ocean



Bubble Bobble by Taito and Firebird



## MARKETING CUTENESS

Gremlin were expert at marketing their cute characters. *Monty Mole*, *Thing On A Spring*, and *Jack The Nipper* were the subjects of classic glossy illustrations in the popular mags of the day. Hewson also scored cute hits with *Gribbly's Day Out* and *Ranarama*.

The packaging of cute video game characters has proved a tremendously profitable business for many companies. Nintendo has literally built a multi-billion dollar international empire on the back of the *Mario* character. The official Nintendo logo is the NES badge on all consoles – but equally synonymous with all things Nintendo is *Mario's* smiling, moustachioed countenance, emblazoned the world over on everything from sports bags to suspender belts.

From *Pacmania* days the merchandisers have been quick to look for opportunities to sell off the back of video game characters. Its just like going to a rock concert. They are no longer content with extorting an outrageous entrance fee out of you they also want you to buy the sweatshirt, sports bag, towel, programme, key ring, poster and so on. Video games are going the same way and - if *Super Mario* breakfast cereal is anything to go by - a good deal further. The *Mario* and Nintendo phenomenon is well documented as it continues to break business records but less known are many of the secondary characters made famous by Nintendo games. *Zelda*, *Link* and *Princess Daisy* are all set to be made famous in a motion picture that has just gone on release in America.

The home computer 'cuties' never had the same marketing muscle behind them that the Nintendo characters enjoy. Few products do. As such they are known mostly to a UK audience. But it is not the individual characters that are important but the style of characterisation itself – which transcends national barriers.

## PUSHING THE LIMITS

Activision pushed cute to the limits with *Little Computer People*. It was the nearest computer games ever got to the cabbage patch doll. Each computer person could be named by his/her owner who then spent most of the time watching the LCP slouching around the house – watching TV, preparing a meal, and other mundane but fascinating daily chores viewed through a cut away wall of the LCP's house. It was the ultimate in computer cute. You could almost give your monitor a hug. But the love affair with LCP's soon passed. The fly on the wall appeal of the game was hampered by a lack of real interaction and it became boring watching the little fellow after a while.

Cyan took advantage of the massive memory of powerful computers for the detailed characterisation of *Cosmic Osmo*. The potbellied alien has the distinction of gobbling up huger chunks of computer memory than any other game. The player becomes familiar with all of *Osmo's* foibles, habits, likes and dislikes. Though the exploration of *Osmo's* world is ultimately as pointless as pursuing domestic chores with a *Little Computer Person*, the game does provide a glimpse of the future of cute games. The power of CD-ROM or, as in *Osmo's* case, a gigantic Macintosh hard disk, provided the ideal medium for *Osmo's* 'cute and cuddly' personality to be played out to the full.

*Osmo* and a variety of 'cute' games emerging in Japan prove that the CD-ROM computers are not going to be used solely for mega-authentic simulations. The designers want to use them to create alien beings with rounded, three dimensional personalities. Be prepared for the cute game to rise again in the 90's - prettier, noisier, and more cuddlier than ever.



# WORLD CUP SOCCER ITALIA 90 THE ONLY OFFICIAL WORLD CUP COMPUTER GAME FOR THE 1990 CHAMPIONSHIP

ACCEPT NO  
SUBSTITUTES

### AVAILABLE ON:

IBM PC	CBM 64 DISC
AMIGA .1 MEG	SPECTRUM 48/128
AMIGA .1/2 MEG	SPECTRUM +3
ATARI ST	AMSTRAD CASS
CBM 64 CASS	AMSTRAD DISC

### PACK CONTENTS:

Free World Cup wall chart

**Plus**

World Cup Story 1930-1990

**Plus**

Amazing facts & figures from all championships

**Plus**

Competition to win :- weeks at the Bobby Charlton School of Football (to be coached by 1st Division Footballers). Plus a Football Strip of your own choice. Videos of the 1990 World Cup Championship. Footballs. T-Shirts.



IBM



ATARI ST



AMIGA

ITALIA '90

Licensed by OLIVETTI official supplier ITALIA '90

Available from W.H. Smiths, Menzies, Boots, Woolworths your local VIRGIN store and all leading software retailers.

©1990 Virgin Mastertronic, 2-4 Vernon Yard, 119 Portobello Road, London W11 2DX.

# ALTER

**D**uring the mid-eighties a series of off-the-wall - not to say positively bizarre - programs appeared from Activision. Games such as *Zenji*, where you emptied your mind and related to your micro in zen-like oneness (maa-an), and *Little Computer People*, the software equivalent of the Pet Rock.

But my favourite manifestation of Californian cookiness was *Alter Ego*, A Fantasy Role-Playing Game About Life. Devised by clinical psychologist Peter J Favaro PhD, it actually encouraged the player to make moral decisions and become emotionally involved with the game play. All of which makes today's flood of arcade conversions, where increased adrenalin production is the only objective, seem immature and unadventurous.

## LIFE GAMES

One advantage of a computerised autobiography is that you can start with any of the seven ages. Relive only your Childhood or forego adolescent angst and plunge straight into Middle Adulthood. But to enjoy the full experience, begin with Birth, cozily curled up in your mother's womb.

The *Alter Ego* manual emphasises that it's just a game, an opportunity to live out alternative lives in a light-hearted fashion. Did you ever wonder what sort of juvenile delinquent you'd have made? Then cut loose, razz your parents, fail your high school grades (you live an American life as no concessions were made to a British version) and have a whole heap of fun as you head towards a premature death.

Most players will want to check out their own personality though, producing a prognosis for years yet to come. You start by letting the computer know who you are via a short, multiple-choice, psychological profile of the sort so popular with *Reader's Digest*. This provides the program with a way to evaluate the consistency of your future actions.

Then it's time to start clicking those icons as you progress through a succession of Life Experiences and Choices. You select which areas of your character you wish to develop, so that a young adult who's not earning enough may select the Vocational icon and try to increase their salary. Alternatively that loose living hell-raiser may just concentrate on hedonistic areas such as Relationships, neglecting High School.

Clicking on an icon presents you with a description of a situation and several responses. The events were selected by Dr Favaro to include typical, life-shaping occurrences and it's fascinating to encounter future experiences, such as the failing faculties of Old Age, or ones you've long forgotten, such as the Infant's limited responses and perceptions of an alien world.

Experiences and Choices differ in that the former are one-off

What are the classics of computer entertainment? John Minson starts this new series with a game which allows you to live an alternative life

## HALL OF FAME EXPLAINED

How does a game qualify for the Hall of Fame? It may have been a best seller in its day or overlooked and underrated. But one thing's for certain, it led the field, either creatively or technically. Clones don't qualify, however competent. And it's got lasting appeal. It's the program you still want to play after years - not weeks. So if you've got any suggestions, drop us a line at ACE HALL OF FAME, EMAP Images, Priory Court, 30-32 Farringdon Lane, London EC1R 3AU.



The game is text based with multiple choice answers but attractive presentation and an engrossing subject transcend the boundaries of limited replies

events while you can return to the latter repeatedly. For example, as a Child you might select a Familial Experience and find your father asking you to help him clear the yard while you'd prefer to watch television. However you play it, the event will go forever, though you'll have to live with the results.

In Adolescence you might return again and again to the Risk Choice though, seeing how far you'll go to gain peer group respect and self-assurance. Life Choices allow you to date, get married, buy a home and raise a family. At the end of each Life Stage you're presented with a brief summation of your current state.

As with any role-playing game, the more you exercise your imagination, the more you become involved. Once you've developed a bond with your character the will to succeed exceeds any quest for top-scores. Finding the right life-partner can be tough; having them die in Old Age is literally heart-breaking.

All of life is here and despite Peter Favaro's reminders that it's just a game, you may learn something about yourself and life if you play properly. And should you really want to try something different, as both Male and Female versions were available, you can see what it's like to belong to the opposite sex!

# EGO

The map presents a path through each of the ages of man (or woman - no sexism here). You click on the events to experience the thrills and traumas of life

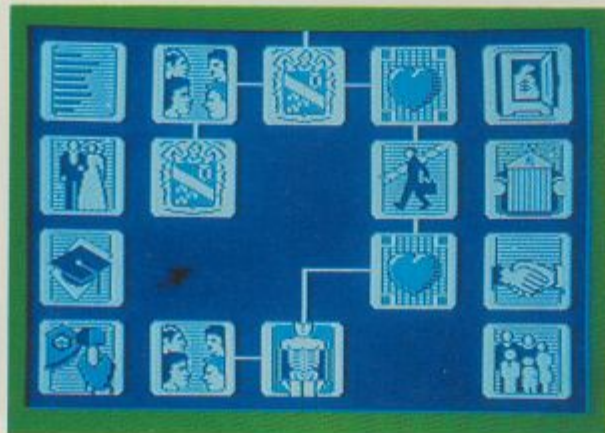

## LAST WILL AND TESTAMENT

If this all sounds too good to be true... it is. Activision has 'de-listed' *Alter Ego*, which means it's no longer available in any of its four formats (C64 disk, PC, Macintosh and Apple II). Which is a tragedy because this is a game unlike any other. Whatever its sales five years ago, surely the more mature computer user of the nineties would welcome serious products like this.

Or better still, consider the potential for a CD-ROM version, with greater variety of Life Experiences and Choices, more cross referencing of events (a drawback with the program is that a Vocational Experience might not be fully consistent with your Work Choice status, for example). Despite this, *Alter Ego* is the ultimate adventure - not dragons and dungeons but into your own consciousness.

# KICK OFF 2



## BLISTERING PACE – PIXEL PERFECT PASSING – SUPERB TACTICAL GAME PLAY

KICK OFF 2 greatly enhances the game play of KICK OFF, winner of THE GAME OF THE YEAR award in U.K. and similar awards right across Europe. A host of new features have been added to the ones that enthralled the players the world over.

Full size multi directional scrolling pitch with the players, markings etc. in correct proportion.

1 to 4 players (Amiga & ST only) option.

2 players TEAM option against the computer or 2 other players.

Hundreds of players, each with a unique combination of attributes (Stamina-Pace etc.) and skills (Passing, Shooting and Tackling etc.)

Instinctive Kick Off joystick controls to dribble, pass, shoot, head or chip a ball and do sliding tackles or scissor kicks.

After Touch controls to bend or dip the ball.

Set Piece Free kicks including dummies to chip the ball or bend the ball round a defensive wall.

9 types of corner kicks with full control of shot power. Long and short Throw In.

Team selection from a squad of 16 with substitution and choice of tactics.

League and Cup competitions with extra time, injury time and sudden death penalty shoot out.

Facility to view, edit and save the action replays and create Golden Shots disc.

AMIGA & ST £19.95

IBM (AT & XT Turbo – CGA, EGA & VGA) £24.95

CBM 64 – SPECTRUM – AMSTRAD £9.95/£14.95

SAM COUPE – £10.99/£14.99



Kit design – 6 styles and 32 colours. (Amiga & ST only)  
Facility to load Player Manager teams for a single game or league game.

Load your own designed Tactics from Player Manager. Red & Yellow cards, 16 different referees, injury time and host of features to create the atmosphere for a game which is a real fun to play.

Special Events provision to load Data Discs or Cassettes for events like World Cup, European Cup etc...

Restricted features on IBM and 8 bit machines.

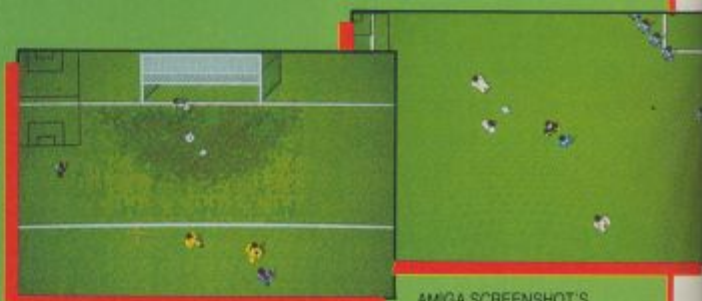

AMIGA SCREENSHOT'S

# ANCO





**A**s exclusively revealed in ACE 30, NEC has finally unveiled a portable version of its popular PC Engine (TurboGrafx) video games console. The \$249.95 TurboExpress colour handheld video game system is completely compatible with all existing TurboGrafx games cartridges (TurboChip games) and can be turned into a colour television with a TV tuner accessory.

NEC's impressive beast utilises active matrix, backlit, liquid crystal display technology capable of displaying 512 colours simultaneously on screen. Amazingly, the compact high resolution TurboExpress display is as good as a normal TV image. With the backlit option, you can use the TurboExpress in poorly lit rooms, cars, outdoors and at night. The screen has a resolution of 238x312 pixels.

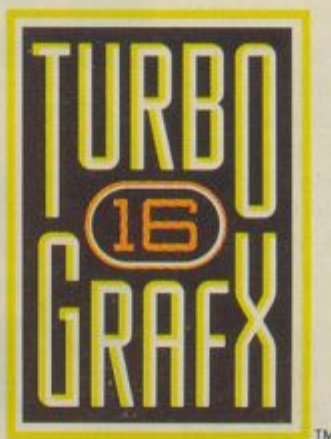

TurboExpress is a smart matt black deck with a Walkman headphone jack for six-channel stereo sound and turbo-fire selectors for the dual fire buttons. Additional accessories for the handheld include a communication link for two-player games, an AC adaptor, battery pack and car cigarette lighter adapter. TurboVision, an optional \$99.95 snap-on tuner, turns the handheld into a portable TV. The tuner also features a video-in port that allows the system to act as a camcorder or VCR monitor.

Hardware features include a HuC6280 7.16MHz processor and 64K of Video RAM. The unit is powered by six AA batteries. Battery play time lasts from between three to five hours. TurboExpress is designed for optimum playability and includes moulded grooves for your palms. The joystick and fire buttons are also well positioned for ease of use.

TurboExpress is the only handheld system fully compatible with an existing home video game system and consequently has the largest library of games titles currently available for any handheld unit. There are approximately 300 PC Engine games presently available in Japan. No free games are provided when you buy the unit.

TurboExpress is due for simultaneous release in Japan and the States in late summer. Unfortunately, there are no firm European release dates from NEC.

The TurboExpress is technically superior to the Nintendo Gameboy mono-handheld, but Gameboy is fast attracting a huge supply of excellent games titles and, at only \$89.95 (with free Tetris game cart, game-link and stereo headphones), is considerably cheaper than the TurboExpress. With predicted sales of five million units this year, the success of the Gameboy is not in doubt.

Atari's Lynx, however, seems to be the handheld system with the most to lose from the release of TurboExpress. The Lynx has only attracted a disappointing selection of mediocre games titles in its first year of existence, whereas TurboExpress can field a good variety of quality games including *Gunhed* (*Blazing Lasers*) - the best vertically scrolling shoot'em-up on any home video games system. Incidentally, Hudsonsoft has just completed *Gunhed II* - look out for a full review in a future issue of ACE.



TV tuner sold separately

Simulated television screen



The handheld PC Engine could turn Atari's Lynx into an endangered species. Rik Haynes grabbed a Turbo Express at the Consumer Electronics Show for a hands-on review...

# LYNX KILLER

## MOVIES

The movie making production process is complex, with, at times, hundreds of people involved and budgets over tens of millions of pounds. However, you can break down the whole thing into seven broad stages.

**1. OUTLINE CONCEPT**

Yes, someone has to sit down in front of a hot keyboard – or cold drink – and think up a basic idea for a movie. It might be an adaption of an existing work, be it a book, TV show or licensed character. It might be something completely original. It might be a "Star Vehicle" for a particular actor. In any case, the Outline Concept is the first stage, where the basic idea is put down in the form of a brief document - and then taken around to Producers and/or Studios.

The Producer is probably the most important individual at the initial stage of the production. He or she is the person who decides whether a project is viable and then has to go on and raise the money and organise the team to make the picture.

If a Producer thinks that a Concept has merit, they'll probably commission a Treatment.

**2. TREATMENT**

The person who had the idea will now take the basic idea and flesh it out, in consultation with the Producer, to a more detailed document. In this might be samples of dialogue – it will certainly include a suggested structure to the movie and full breakdown of the action.

**3. SCREENPLAY/STORYBOARD**

Now comes that stage where a Writer comes in and writes a full script for the movie, including all the dialogue and some minimal direction. It has to be said that this document is used as a working basis for the film – but is subject to radical change in detail when the movie starts to shoot. Writers' egos are considered expendable in movie-making!

The Producer will show the script to the Director he wishes to shoot the movie and will also submit it to Principle cast members that they might want to play a particular role.

The Screenplay is the basis for the dialogue – and many projects get no further than this. If the Concept and the Screenplay don't excite a critical mass of individuals, that's it. The project is dead.

The Storyboard is something that is working on later in the project – being a rough shot by shot cartoon representation of the whole of the movie. This moves us into...

**4. PRE-PRODUCTION**

Before anyone gets in front of a camera, there is the huge job of preparing for the shoot. This is not so much making a film, it's an invasion of Poland.

Acting and Technical staff – plus equipment – have to be hired. Locations sought out, sets constructed, costumes made, rehearsals done – and a million of other things, all, hopefully, to a strict budget. The shoot itself has to be planned carefully and a schedule drawn up for that. Naturally, any delays during shooting - when most people are hired and most cost incurred – can be financially disastrous.

**5. SHOOTING**

This is where the Director comes into his own. The shoot is completely under the control of the Director – whose word is law. Unless they're dealing with particu-

# Film Production

VS

# Game Production



larly famous stropy actors, in which case it's more like being a babysitter.

This is where the photosensitive emulsions are exposed to light and the part of the process we are most familiar with, takes place. Cameras roll, actors act, accountants worry about going over budget.

Beforehand, the shoot has been planned down to the last detail and there is usually little margin for error.

One interesting thing – the scenes are filmed in the sequence that is make the most efficient use of resources. That is almost certainly not in the same sequence as you see them on screen in the final product. Lights, Camera, Action!

**6. POST-PRODUCTION**

Once the basic film is shot, all the Director really has is several thousand feet of useless celluloid. Now the thing must be edited into a comprehensible whole with the addition of any special effects and sound – which is re-dubbed completely... usually the very last thing to be done.

Editing is just as important as the shoot – it's in the cutting room that a film can be raised to a new height of wonderfulness or be utterly ruined.

**7. PRINTING, DUPLICATION, RELEASE**

After all that time, the final cut is printed, duplicated and sent out to the cinemas – once the marketing terms have done all the pre-release hype and advertising. Now you, the punter, gets to pass opinion after 90 minutes or so have gone by – over something that probably has over 2 years to produce since the original idea came about.

# That's Entertainment

# MICROS

Compared to making a movie, producing a computer game is a relatively simple business – but still fraught with its own peculiarities, pitfalls and perils. Few have a six figure budget, none a seven – as yet! Though again, it can be thought of as a seven stage business.

## 1. OUTLINE CONCEPT

It's back to the drawing board again, where someone, somewhere, sitting in a pub – or as it happens, driving through the Nevada Desert – has that lightening flash of inspiration that we call a Concept. Scribble it down onto two sides of A4 and you have yourself an Outline Concept. Although it's rare for a Software House to commission on the basis of an Outline, although they do on occasion. It's the distillation of the game. A bad idea will make a bad game – with a good idea, you've at least got a chance.

## 2. STORYBOARD/DESIGN

Now is the time to get the word processor fired up and start thinking seriously about how to put some meat on the bones of the idea. After a period of time, consultation with prospective publishers and much deep thought, the result is a detailed design document that will detail the whole of the action involved in the game. Often this might include some hand drawn graphics – a Storyboard (although this is not the detailed shoot schedule that is used in the movies) – or more likely a short demo of the major programming techniques and/or graphics that are to be used within the game.

At this point it is likely that, if your idea is any good and you have a programming team to write it, you can get external finance and the commitment to publish.

## 3. TECHNICAL SPEC

Now a programmer has to get to grips with the design document and break the whole thing down into individual programming tasks. This is a disciplined business – and will form the basis of a programming schedule that the team will have to keep to in order to keep a prospective publisher happy.

## 4. CODING

This is the nitty gritty, the equivalent of the Shoot in Movie terms. Thing is, it's likely to last six to nine months for a game of any complexity or size – six to

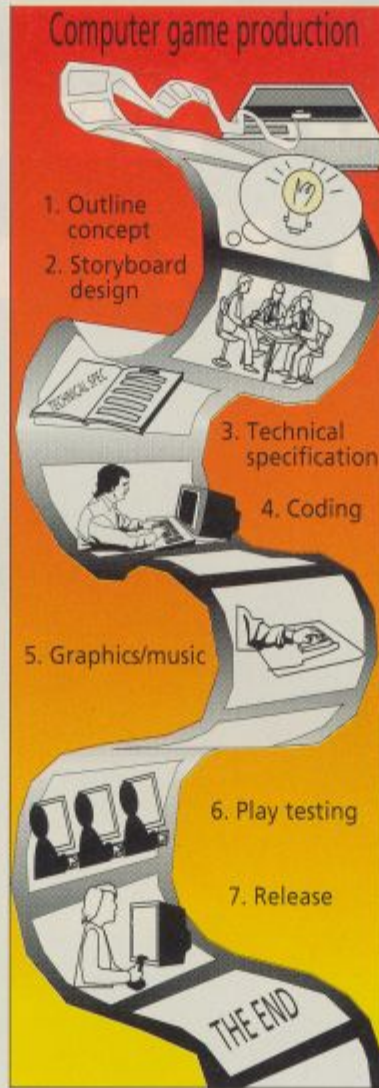

nine months of constant pressure to perform and deliver. Programming a game can be fun, but it's also a hard slog that requires application and self-discipline. A programmer will often be working as part of a team of people working on the same project - particularly if it's multi-format. One programmer tends to work on one processor type.

## 5. GRAPHICS AND MUSIC

At the same time as someone is writing the hard code of the game, there'll be someone else who is drawing all the graphics and yet another someone else who is working on the sound. Of the two, it's the graphics guy who is most important. Good graphics are hard to come by. If you find someone who can produce great graphics, you tie them down and offer to have their children. Music is easier to do and tends to be plugged in at the end of the game. This is a throwback from the times when all machines could do was beep – it's likely that sound will get more important as the machines and memory allow.

## 6. PLAYTESTING

OK, so the game is almost finished. But is it any good? This is where good playtesting comes into its own. Of course, the gameplay will have been monitored by the programming team and the publishers throughout the course of development, but ideally, at the end of the project, panels of users who are unfamiliar with the game are brought in to give it a thorough testing. It's here that simple faults, often overlooked by those too close to the project, are found.

It's also true that playtesting is sadly neglected by the majority of UK software houses – hence the bugs that appear in released version of the game.

## 7. MASTERING, PROTECTION AND RELEASE

The technical side to getting the game onto a disk, then protecting it and then duplicating it could alone be the subject of a book - albeit a fairly boring one. Imagine – you have to copy the game to duplicate it... so if the protection is exceptionally good, you run into duplication problems.

Once the disk is duplicated it's stuffed into a box and from there into a warehouse - waiting for the marketing and advertising to hit and the orders from the punters to come flooding in. Hopefully. Then you get to play it. Once you boot up, it's likely that over a year has past since some poor sod had the original idea. Was it worth it?

**USA punters spent around \$5 Billion going to the movies last year. That's a lot, but if you combine the whole of the videogame business, coin-op, floppy and cartridge, you come up with roughly the same figure spent on computer games... who'd have thought it? Both are Big Business alright - and with the advent of CD Storage, it looks like these two strands of the enter**

**tainment industry are going to get closer and closer as time goes on. But how close are they already?**

**John Cook delves into the secrets of the confessional to show you how movies and computer games are made... and where celluloid and silicon interface**

# ment!

**Find out its limits.  
Look in the mirror.**



**Introducing the powerful new Atari 1040 STE. With such an awesome machine, we're convinced the only limits you'll come across are your own.**

Based on the incredibly successful 1040 STFM, the 1040 STE itself goes beyond the limits of its predecessor.

The 'E', by the way, stands for 'Enhanced'. But once you've discovered its amazing array of features, you may consider 'Enhanced' to be the understatement of the decade.

Perhaps the most outstanding feature of the 1040 STE is its graphics. Its palette contains over 4000 colours (all right, 4096 to be exact).

To ensure precise and realistic images, the STE features 'hardware scrolling', enabling smooth scrolling in any direction and split-screen effects. And, with the SM124 monitor, you'll get razor sharp black-out-of-white text that's as clear as the type on this page.

To complete the picture, it is able to 'phase-lock' its video output to an external video source, permitting direct linking to a Genlocking device.

The 1040 won't just have your eyes swivelling in their sockets. Your eardrums will also take a pounding from the 8-bit PCM stereo sound.

The new PCM (Pulse Coded Modulation) sound system's two chips allow the 1040 STE to replay high-quality sampled sounds, in stereo, without burdening the CPU. Or, for even more of an earblasting, just add a couple of RCA output jacks and power the sounds through your own stereo.

Of course we mustn't forget memory. One megabyte of RAM comes as standard. If that's not enough, the 1040 STE provides four SIMM sockets. Simply plug in some SIMM (Single In-line Memory Module) boards and boost the RAM up to four megabytes.

To help you handle all this technology, we've added even more: a Blitter chip, capable of shifting data at high speeds independent of the CPU, and a new version of TOS.

The TOS 1.6 (operating system) has an enhanced file selector with drive-change buttons, improved desktop with file move, MS-DOS compatible disk formatting, and better application installation and auto-booting facilities.

As you'd expect, there's a huge range of peripherals including hard disks, floppy disks, laser printers, colour monitors and even Megafile 44, Atari's unique 44-megabyte removable hard disk.

As well as all this hardware, there are hundreds of software programmes for the 1040 STE - we're even throwing in the ST-Series Productivity and Leisure bundles free.

The Productivity bundle features a database, spreadsheet, word processor and business graphics package, and there's S.T.A.C., FirST BASIC, Hyperpaint and Prince in the Leisure bundle.

If you're itching to get your hands on the controls, there are two 15-pin analogue controller ports (which accept paddles, light-guns and light-pens) and a 9 pin mouse port and joystick port.

With adaptors, up to six people can use the 1040 at one time. Just in case it's too much for one person to handle.

At £499.99 it certainly won't be too much for one person to afford.

The ideal computer at the ideal price, you may think. We think so, too. But there remains only one potential problem: not whether you'll make impossible demands of the 1040, but whether the 1040 will make impossible demands of you.



Please send me further details of the 1040 STE and other Atari products.

NAME: \_\_\_\_\_

ADDRESS: \_\_\_\_\_

POSTCODE \_\_\_\_\_

Please send to Atari Corp (UK) Ltd. Atari House,  
Railway Terrace, Slough, Berkshire. SL2 5BZ.

**ATARI 1040STE**

**WITHOUT IT YOU'RE JUST PLAYING GAMES**

# ROTOX

**ROTOX** – The man was a trooper in the elite marines, injured on combat duty. **ROTOX** – The **Cyborg** has been transformed by 22nd century science into a devastating computer, assisted fighting machine.

**ROTOX** – The game features a revolutionary technique called **ROTOSCAPE** which allows the whole landscape to revolve around you providing a 360° nightmare environment of deadly machines and hostile life forms. **ROTOX** – a revolutionary new experience.

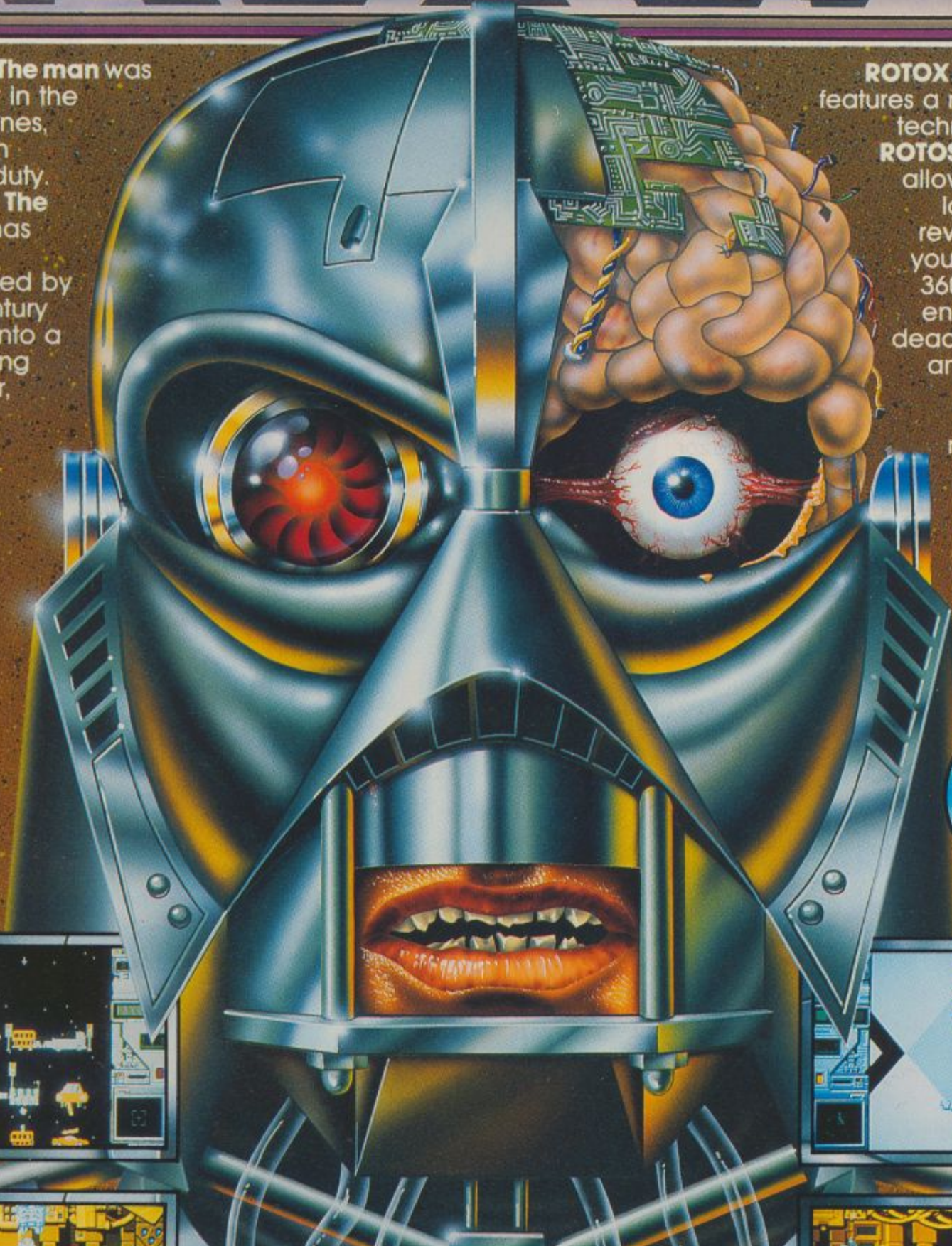

INCLUDES  
"THE ROTOX FILES"  
AND FREE ROTOX  
STICKER!

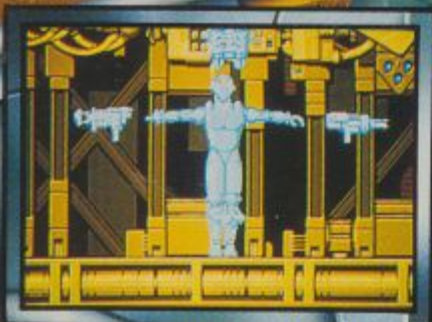

Screen shots from 16 bit formats.



YOU SAY YOU WANT  
A REVOLUTION –  
THIS IS IT!



IBM PC & COMPATIBLES  
ATARI ST · AMIGA

U.S. Gold Ltd., Units 2/3 Molford Way, Holford,  
Birmingham B6 7AX. Tel: 021 625 3388.

ROTOX © 1990 U.S. Gold Ltd./Creative Materials Ltd. All rights reserved.  
ROTOSCAPE © 1990 Creative Materials Ltd. All rights reserved.

# It All Shapes Up

**The good, the Bad, the very Bad – John Cook gets on down to the arcades to check out the latest coin-ops and comes back funky**

**NEO-GEO  
- the shape of things to come**

**W**ell, ACE told you all about the SNK's Neo-Geo home console last issue – and gave you a chance to win one – now you'll be interested to know that a cabinet version of the machine is going to be making it into the arcades this summer.

The trade can now buy a custom manufactured stand-up cabinet with the guts of the machine inside, together with a quality monitor, speakers, two industrial strength joysticks and four fire buttons per player. The cartridge array inside the box appears to be able to hold up to six games at once, selectable by the player when you put your money in the slot. Whether or not the arcade operators will want to have six games inside a single cabinet at one time... well, that's a matter for debate.

The units were on show to an invited trade audience recently and seemed to be fairly well received. However, anyone expecting performance vastly in advance of present PCB technology was going to be disappointed, proving that, for the present at least, dedicated units experts such as Atari and Sega can rest easy in their beds.

No-one doubts that the Neo-Geo is impressive for what it is - the specs suggest it has the potential to be the most powerful home console to date (as does the price) but the first generation of software simply does not grip like it should if this format is not going to be yet another also-ran in the arcades.

*Baseball Stars* – nice game, but is anyone in the UK (or Europe for that matter) ever going to get that excited about Baseball? *Motorcycle Lord* – a potentially innovative mix of role-playing (yes role-playing) and motor cycle racing. Bizarre? Yes. Destined to set the pulse racing – up against corkers like Taito's *WGP Grand Prix* and Sega's *Racing Hero* (to be reviewed next issue)? No way.

*Top Play Golf* is a fine title, but I'd put my money on Sega's *Super Masters* as being a better game. *Magician Lord*? Good quality but uninspired arcade adventure action that makes no great effort to set itself out from the crowd.

My favourite out of the present crop of games on offer was *Nam 1975*. This hybrid cross between *Op Wolf* and *Cabal* was easily the most playable of all the titles on view, with good use of graphics and sound effects to boot.

This criticism is judging the games by arcade standards, of course. Now if we were talking



*Magician Lord on the Neo-Geo: tasty graphics, unoriginal gameplay*



*The revolutionary Neo-Geo home and arcade video games system allows you to store player data on your IC smartcard. You can play the game at home, save your position onto the card, and resume the game in the arcades as if nothing had changed*

about home console games – that would be another matter. There's no question that the Neo-Geo is powerful when compared to any other home game format. But the price? Say £250 for the unit, then £150 for the software?

No-one is going to pay £150 for a shoot-em-up - and to generate a significant rental market, the games themselves are going to have to be of outstanding quality, that is, better than those on offer right now. Considering the strength of some of the new Genesis/Megadrive titles, the Neo-Geo has got its work cut out to penetrate the home market to any degree – although it may point the way to the end of PCB's as the trade knows them today.

**SMASH TV  
- the shape of things ten years ago?**

**T**he equivalent of a video-game hippy is the sort of guy who shows you his *Defender* blister during your first conversation. Ugly thought, huh? Three pints later and it's highly likely that the subject of Williams Games in general and *Robotron* in particular is going to come up.

In case you didn't know, Williams (the astonishingly successful pinball manufacturers) used to be a major player in the video market, back in

the early 80's. It probably helped that *Defender*, its first release in November of 1980, was one of the most successful games in the history of the industry.

The follow-up, *Stargate*, followed just under a year later then a disappointing title that never made it over to the UK in any numbers, *Make Trax*. Williams hit gold again, though, with *Robotron 2084*.

This was a game played on a single static screen with you controlling a robot sprite with two joysticks. One moved you around the screen, avoiding the vast mobs of enemy robots that inexorably followed your every step, and the other controlled your direction of fire.

This meant that you could, for the first time in a game, fire in a direction other than that in which you were moving.

*Robotron* was quite popular, but was not in the same league as *Defender*. Williams carried on in the business for another year or so, coming up with the excellent *Joust* and the much maligned



*Smash TV: the Price is Right with chainsaws?*

INCLUDES  
ROTOX FILES™  
FREE ROTOX  
CHECKER!



TIBLES  
GA

All rights reserved.

Sinistar (best conversion ever on the BBC B), but never did much more after that.

So now it's a bit of a surprise that, cue fanfare, we are now faced with a new Williams coin-op after all these years. Alas, it's not a 4th generation *Defender*, although we can only hope that something similar might be on its way. But what it is, is the next best thing after that - a 4th generation *Robotron*.

Called *Smash TV*, the scenario is a kind of *The Price is Right*, but with chainsaw's! It's a gameshow, played on a single screen, where you move around picking up gift-wrapped prizes and money and power-ups. Problem is, the room gets a bit crowded, what with all these baseball bat wielding skins, who pour out, lemming-like, from the edges of the screen, with only a single object in mind. To hit a home run against your cranium.

Using controls identical to *Robotron*, we are talking about senseless violence on a mind-boggling scale here, with the body count reaching thousands in an average game. Worry not, however, as it's all done in the best possible surrealist taste, with excellent graphics and animation - and hardly surprising given the level of audio technology in the average pinball - superb sound.

The thing has humour, gameplay and pace and despite that unsophistication of the action it is highly likely that you'll want to play more than a few games of this baby. More please Williams.

**MOONWALKER**  
- the shape of the dollar sign

Michael Jackson is Bad. No arguments there, eh. His films are pretty awful as well, so I hear, such that even after spending loadsa money on *Moonwalker "The Movie"* it really didn't make much of an impression at the box office. Come to think of it, neither did the US Gold licensed home computer game which - apart from ACE - didn't get reviewed much at all by the home computer press. That Bad.

Well, because Sega and Mikie Baby, as I call him, are so kissy together - something about



Take it away Michael...



Putting the spotlight on Sega's Moonwalker coin-op



Nintendo's Dr Mario - the latest Mario game to ship on silicon

Red and yellow and pink and green, orange and purple and blue, you can play Sega's Colours too

Sega lending him a *Galaxy Force* for the duration of his Japanese tour - said megastar has come up with a concept for a coin-op that Sega has jumped on like a ferret on a rabbit flavoured icelolly. In front of the joystick, I steered myself for a truly Bad experience. In fact, it was great.

The game itself is a fair to middling isometric kicky-kicky job, in the same mould as *Escape from the Planet of the Robot Monsters*, but much more "realistic" graphics. Up to three of you (all Michael Jacksons) use your mystic zapper powers on Evil monsters and have to free kiddies that are tied up. Sounds tedious, but the game has a number of things going for it in a big way.

For a start, it has vast amounts of Jackson soundtrack. Now, love or hate the guy, he has written some pretty nifty riffs in his time and copyright music is lavishly played throughout. Good.

Next the game has polish and some very neat touches. Leave your sprite alone for a few seconds and he starts bopping in true Jackson style. Press your smart bomb and the scene dims, a spotlight comes down on you (and your clones) and you start to bop to the sampled sound of "I'm Bad". So do all the monsters, choreographed in synch with you! And at the end of the sample, they all blow up! This is fun!

The graphics themselves are excellently drawn and animated, bringing in the mood of a film set, somehow. In fact, the whole mood of the game feels like a video. The action itself seems to be choreographed and after a while it's easy to imagine that this is an interactive version of the *Thriller* video itself.

After the sad offerings on home format - and Genesis - *Moonwalker* coin-op is a great example of how to exploit a licence to the full. Me - well, I'm looking forward to the Kyle Minogue version of *Op Wolf*...

**COLUMNS AND DR MARIO**  
- have we seen this shape before?

Let's not go on about *Tetris* too much and what a video game visionary I am because I persuaded Mirrorsoft to publish it in the first place, shall we? It's simply a phenomenon that has irrevocably demonstrated that simple games can be classics, if the basic concept is sound.

Fine - and since *Tetris*, almost every coin-op company has been trying to repeat that success. No-one has yet, but *Columns* and *Dr Mario* are two games that are going to try.

From Sega and Nintendo respectively, both are played in the *Tetris*-style U-Shape playfield,



with shapes falling down from the top to the bottom. Only this time, it's not different shapes you are manipulating, it's colours.

In *Columns*, 3\*1 shapes fall from the top of the screen. You can't rotate them, but pressing fire changes the sequence of colours within a shape. So looking from top to bottom, Red, Green, Purple will become Purple, Red Green. You can manoeuvre the shapes left/right with joystick as they fall down the screen.

The shapes stack up, but if you get four of same colours in a row, then these disappear anything on top falls down to fill in the vacated spaces, which may cause another four-in-a-row, etc, etc.

*Columns* is interesting, but various things make it not great. Any four in a row - horizontal or vertical or diagonal will disappear. That makes the game very confusing - as odd chain reactions can occur that baffle the player. You don't feel in control. There's no progressive difficulty either, other than speed of falling of the blocks. No bonuses for getting more than four in a row so it seems.

With some more work at the design stage *Columns* could have been a classic. As it is the game is something of a curio that is well worth playing, but fails to grip in the way *Tetris* did. Nice try Sega, but no banana.

*Dr Mario*, on the other hand, sticks to basics and consequently is a lot more fun. Again you have the *Tetris* format, but what comes falling down are 2\*1 shapes, which you can move and rotate, although the sequence of the colours of course, set.

As I recall, there are four colours - all you have to do is make four or more of the same colour in a row and, yes, the line disappears, etc, etc.

Wildly simple, *Dr Mario* has the edge on *Columns* as it stands, despite the inferior graphics and sound. I'm sure there's a moral there somewhere.



# Tracon and Rapcon

## Air Traffic Control Simulators



### A game, or a deadly reality? . .

These two new programmes bring a dimension of reality seldom achieved in a computer game. The screen display and controls are very close to real ATC operations, and commands and responses are both displayed through your PC's internal speaker.

**Rapcon** is an out and out Military Air Traffic Control simulator. You handle the movements of F14 and F16 fighters, and B52 and B1 bombers amongst others, each flown by a hot-dog pilot who thinks he is the ultimate Top Gun. You have to vector and separate each onto final approach whilst the weather deteriorates, aircraft lose engines and nuclear laden bombers swing off course. Can you handle it?

Available for IBM PC or compatible with 512K memory. Options: Microsoft compatible mouse.

**Tracon** is a Simulator based on Civil Aircraft movements. You'll handle traffic on a 'real' ATC radar scope and cope with wildly fluctuating traffic loads from the relative calm of midnight to 'peak time' travel. Stormy weather and pilot errors test your skills to the limit. You get a realistic traffic mix in a choice of sectors including a European control zone.

Available for IBM PC or compatible with 256K memory. Options: Microsoft compatible Mouse. Audio cassette tape player.



*Wesson  
International*

# M I N D S C A P E

For further information on Mindscape Products and your local Dealer, contact:  
Mindscape International Limited, PO Box 1019, Lewes, East Sussex BN8 4DW. Tel. (044 486) 545/547



# HIDEOUS MUTANT LIFE FORMS LURK AROUND EVERY CORNER

## FEDERATION QUEST 1 B.S.S. JANE SEYMOUR

A fleet of huge biological survey ships has been immersed in deadly radiation, with many alien life-forms roaming its rooms. Your mission is to penetrate the ships, locate and repair the damaged systems, capture the aliens and finally, steer the fleet back home. This mammoth strategy role playing game encompasses more than 4,000 rooms spread across 20 ships.

Available on:  
**ATARI ST/STE  
& AMIGA**



"Hugely entertaining and deeply involving."  
Steve James, *CU Screen Star*.

"If you have a spare 3 weeks and a coffee machine next to you, buy Federation Quest 1 BSS Jane Seymour."  
Paul Glancey, *C&VG*, 91%

"Well executed, well playable and well worth a look."  
Paul Lakin, *Zero*, 89%



Screen shots from various formats.

All mail order enquiries to: Gremlin Graphics Software Limited, Alpha House, 10 Carver Street, Sheffield S1 4FS. Telephone: (0742) 753423

# ACE New Worlds

## MANHUNTER 2 SAN FRANCISCO

When trouble strikes, who you gonna call? SIERRA-ON-LINE provide the answers

The prequel to this game, *Manhunter - New York*, was a hot Sierra adventure. It boasted loads of puzzles, an interesting control system and stacks of gameplay. So good was this product that Sierra have done the unexpected (ha ha) and created a sequel. The story goes something like this...

As a Manhunter on the trail of a notorious mass murderer whom you know only as Phil, you searched the heights and depths of New York. Unfortunately he managed to evade you and travel to San Francisco. In your haste to find him the only soft spot you can find to land your already damaged craft is the body of another Manhunter, whose identity you quickly adopt. Soon you realise that things aren't quite right in 'cisco. Something stranger than normal is going down...

The key to the game is based around a little Z88 variant called a MAD (Manhunter Assignment Device) terminal. When used to hack into some pretty major superpower hypercomputers, the Mad gives you instant access to small amounts of information on every human being in the current city. Once you have a lock on somebody, by using a handy little tracking program, you can watch the subject's most recent movements around the city. Watch carefully where they go, and more importantly where in each room the visit. Clues are everywhere.

### RELEASE BOX

ATARI ST	£29.99dk	IMMINENT
AMIGA	£29.99dk	OUT NOW
PC	£29.99dk	IMMINENT

No other versions planned.

**LANDSCAPE** .....70  
Not the greatest graphics you've ever seen. The city is large but locations are only accessible at certain times.

**ENCOUNTERS**.....55  
These are few and far between, and unfortunately you rely on them to get you anywhere in the game.

**CHALLENGE**.....90  
This is a very difficult game. beginners will find it too frustrating and should try some other Sierra games first.

**SYSTEM** .....50  
*Manhunter 2* utilises a very idiosyncratic system which I found annoying, but it does work, just!

### ACE RATING 550

If you don't mind the idiosyncratic system, and the initially slow pace, there is quite a brain-boggling challenge here for advanced adventurers. Beginners should steer clear.



Yet another location that you are barred from entering, until you find the correct person

Once you have determined some direction to your search (by tracking people) the places they have visited become accessible on the map. This is apparently to stop you wasting time going into empty buildings. I personally find it a little disheartening to have a massive city with, initially, only four accessible places in it.

All movement is mouse controlled, as normal. Movement around the city is reached by clicking

We check out Sierra-on-Line's latest opus, as well as the most recent arrival in the long-running AD&D series. Pat Winstanly rounds off this month with a luscious selection of hints and tips contributed by your good selves



*Manhunter 2 is certainly not for the faint-hearted - there is blood and gore aplenty*

on a building you want to visit when in map mode. The map is pretty large, so there's a lot of searching to be done. The real problems with playability start when you get to the close up, first person perspective screens at your destination. Rather than work like a Lucasfilm product, where the mouse pointer is the game pointer, *MH2* uses the mouse pointer to click on the area you want the game pointer to move to, which then moves far too slowly. By using this system, searching a location for clues now takes a most annoying length of time.

As with *MH1*, there are lots of little arcade sequences thrown in. I found these could occasionally be a little too difficult, and might frustrate a lot of players.

Another point which may annoy beginning players is the very limited object manipulation. There is little to do with items but look at them, which can also make the first few hours of play frustrating.

While this is by no means Sierra-on-Line's best release, it will no doubt appeal to experienced adventure fans. Beginners and occasional adventure players may find it a little too hard, and consequently quite limited.

● Tony Dillon



There are some shady folk about in 'Frisko - can you discover what they are up to?

### AMIGA VIEW

*Manhunter 2* is for 1 meg machines only, and there is still a lot of disk accessing. Graphics and sound effects are copied from the PC game. Thankfully, Sierra claim they will never directly port artwork from the PC again. Mouse control is not particularly well-implemented, there is an unusual double-cursor system which doesn't really work very well.

# SECRET OF THE SILVER BLADES

US GOLD/SSI discover something nasty at the bottom of a mine in their latest AD&D adventure – and I don't mean Arthur Scargill...

This is the third volume in the *Forgotten Realms* series of AD&D adventures. SSI have already had a good run out of this TSR license. As well as *Forgotten Realms* there is the *Dragonlance* set of games, which employ a different, and graphically superior game system to that found in *Forgotten Realms*. And for those who still enjoy playing D&D without a computer, there are a set of utilities to aid Dungeon Masters.

The idea of taking the most popular table-top role-playing game and transplanting it to a computer was initially greeted with enthusiasm. One of the problems with the manual D&D system was the tedious dice throwing, and the frequent necessity of wading through page after page of combat tables. This sort of number crunching is exactly what computers are good at, so why not let the computer take care of that, and leave the player to enjoy concentrating on solving problems and manipulating his or her party during combat.

Unfortunately the reality is a far cry from the dream. One thing that computers are not very

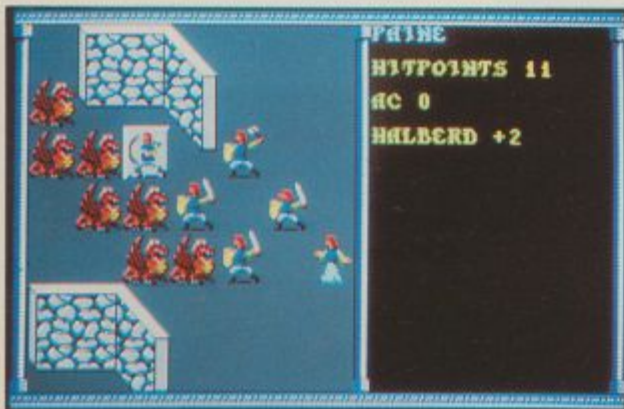

Combat is a regular occurrence in AD&D so you had better get used to it.



The mining village of New Vergridis may look peaceful enough but...

**LANDSCAPE** .....60  
Quite a large playing area, but each location looks the same and it is easy to get lost without careful mapping. The boring pseudo 3D screens are occasionally relieved with superbly drawn 2D images.

**ENCOUNTERS**.....70  
Most encounters are of the extremely violent kind, and you will soon get tired of not being able to walk down a corridor without having to fight off at least two hordes of rogues and brigands.

**CHALLENGE**.....65  
It is difficult to survive this game with a weak party, and you will have to apply lots of common sense if you are to remain intact, but good old fashioned brainwork is not a major requirement.

**SYSTEM** .....50  
The menus are, at times, unbearably slow. Add to this an over-fussy combat sequence, and you don't have the world's greatest game system. It is just about usable though.

## ACE RATING 650

An imaginative scenario spoilt by a poor problem solving to combat ratio, and a game system very much in need of updating.

good at delivering is atmosphere and spontaneity – two of the aspects that make human moderated D&D games so appealing. This was where the first game in this series, *Pool of Radiance*, fell down, and unfortunately the fault is by no means rectified in *Secret of The Silver Blades*.

Following your adventures in *Pool of Radiance* and *Curse of the Azure Bonds* (yes, you can use your characters from those modules), you are beginning to hanker after a little more excitement. Fortunately, or unfortunately, depending on how you view the situation, you find yourself materialising in the mining town of New Vergridis.

While opening up a new mineshaft, the citizens of the town have unleashed an ancient evil. The creature begins to plague the town and threatens to put an end to the mining that is the towns livelihood.

By sacrificing their treasury to the Well of Knowledge the townspeople manage to summon your party. You are their last hope (God help them)! Although you materialise in the town with no equipment the hapless townsfolk donate to you all that remains of their treasure and equipment (and let me tell you – it ain't a hell of a lot!). A quick jaunt around the town and the mayor's house (which you can use as a base) will soon reveal other useful items as well as the occasional clue.

Clues, as you will know if you have played the other games in this series, are cleverly tied up to the adventurer's journal supplied with the disks. Cross references are made to entries in the journal, rather than the text appearing on screen. There are several advantages to this way of going about things. First, it is a rather neat anti-piracy device. Secondly, it saves a hell of a lot of memory and disk accessing. Finally, the entries are easily referred to again should you need to check up on a few facts.

Once you are fully equipped you can begin to solve the mystery of the new mine shaft and the evil that has been unearthed there. If you think this sounds like it might be a departure from the usual AD&D hack and slay stuff – forget it! There is still far too much reliance on the tediously slow combat system. There are better ways to handle combat in games of this type – just take a look at the superficially similar but far superior system in Origin's *Knights of Legend*.

*Secret of the Silver Blades* is not a bad game. Once you have resigned yourself to the slow menus and overly complicated combat, then it is quite easy to get involved. That does not alter the fact that there are better games of this type around which have more to offer the traditional adventure player.

● Laurence Scotford

### PC VIEW

You will need at least two floppy disk drives to play this game or, better still, a hard drive. The game is compacted on the original disks and needs to be decompact before play. The only graphics modes supported are CGA and EGA, but some of the EGA screens do look very attractive. Control is simple enough with the keyboard, but mouse and joystick are also supported. If you are lucky enough to own either an AdLib or CMS sound board then you will also be treated to decent sound, rather than the PC's usual squeaks.

### RELEASE BOX

ATARI ST	TBA
AMIGA	TBA
PC	£29.99dk OUT NOW
C64	£24.99dk IMMINENT
No other versions planned	



William Gibson gets rezzed in Neuromancer from Electronic Arts

## NEW RELEASES

From **Electronic Arts** comes the news that *Neuromancer* is to be released on the Amiga. The game is described as science fiction RPG where the player takes the role of a hacker plugged into a vast computer system in the twenty-first century. The more the player interacts with other hackers, the more passwords and tips will be gained thus giving access to more databases. Should be available for £24.99 by the time you read this.

Also due for release by **EA** is *Dragon Wars* for the Amiga £24.99 which comes from **Interplay Productions** of *Bard's Tale* fame. In the watery world of Oceana, one island, Dilmund, is reputed to have streets paved with gold, which is why the player is trying to reach it. But, the once good King Drake appears to be making a takeover bid for Oceana and has forbidden magic. Several islands have threatened to unleash their guardian dragons and Dilmun is under threat of self-destruction in the ensuing chaos. The player's task is to discover why magic has been banned and stop Drake's conquest. Characters can be imported from *Bard's Tale I & II* and the system offers an automapping mode. Should be available in July.

Meanwhile **Activision** announce a host of **Sierra-on-Line** releases which again are of particular interest to Amigans. *Kings Quest IV* should be available at the time of reading for £34.99 and sees Rosella meeting creatures from ancient legends such as unicorns and ogres in her search for the one item that can save her father. *KQIV* is already available for the ST and PC at £24.99 and £29.99 respectively (why the great difference in prices?) as is *Police Quest II* which is also due now for the Amiga.

In *PQII* you take the role of Sonny Bonds, a homicide detective on the trail of an escaped convict. The escapee is sworn to kill everyone who helped to convict him and the game features bomb disposal squads and underwater detective work.

Yet another current Amiga release from **Sierra** is the first of a series of games designed by Lori Cole which aim to introduce the role player to adventures and vice versa. *Hero's Quest* sees you in the Alpine peaks where, having recently completed a correspondence course in "How to be a Hero" you must dispose of a band of brigands to win the title of "Hero". Your choice of character class alters the

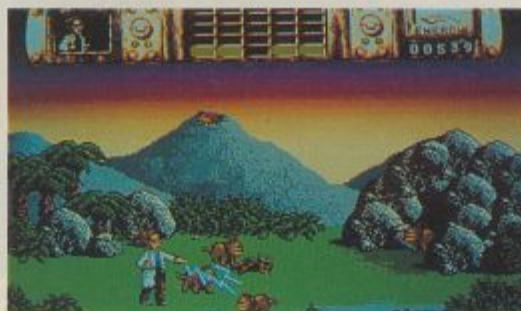

Time Machine is an off-beat quest in which the Professor plays God

scenario so the game can be played several times.

The Amiga is certainly a busy machine right now. From **US Gold** comes *Sword of Aragon* £29.99 which is an **SSI** fantasy wargame that combines hex style movement and battling with the economic problems of keeping your citizens happy. The PC version was reviewed in issue 25 so check that out for more detail.

Finally from **Activision** comes a **Vivid Image** game, *Time Machine*, billed as a "4D fantasy role playing arcade adventure" (hope that doesn't mean jack of all trades and master of none) where Professor Potts is thrown back to prehistoric times when bombed while working on his time machine. Your task is to interfere with evolution to stop the bombing whilst trying to protect your forbears and environment to prevent your own extinction. Due for release in August on C64, ST, Amiga, Spectrum & Amstrad.

## HINTS & TIPS

**JINXTER** – getting started by **Charley Allan**  
First show the ticket to inspector when he asks for it and press the button after the bus goes past the first stop. Then get off and take the key ring. After reading the document open the gate and go north. Unlock the door with the iron key, open the door and go north into the house. In the house you will need the cello case, the sock under the bed, the shoes in the wardrobe, the tin-opener on the kitchen table, the bottle of milk in the fridge and the tablecloth in the conservatory. Unlock the conservatory door with the iron key, open the door and go north into the garden. Take the gloves and go north then east then wave the tablecloth. Drop the tablecloth and go southeast. Go east and get the bottle, west then southeast. Go south and take all (make sure you get the bung). Go north, north-

west, south and unlock the door with the rusty key. Open the door and go southwest into Xam's house.

**ALTERNATE REALITY (THE CITY)** – tips by **Adam Lock**

How to be "good" – Offer gifts to the poor, work as much as possible, never start fights, only charm or trick evil characters, don't join evil guilds.

In order of good to bad the guilds are order, law, light, physician, blue, star, green, thieves, chaos, red, assassin, dark.

## POTIONS

<b>Amber</b> plain	cure poison/sour spirits
<b>Black</b> acid	invincible to fire
alkaline	invincible to water
bitter	delusion
dry	invincible power
plain	invincible
	sharp/mental/fleetness
salty	invincible air
sour	strong poison/invincible earth
sweet	invincible blunt/cleric
<b>Clear</b> acid	acid/cleansing
bitter	unnoticeability
dry	mineral water/invisibility
plain	water
salty	salt water
<b>Green</b> sour	heal minor wounds
sweet	ugliness
sour	protection +2
sweet	dumbness/protection +1
<b>Red</b> acid	vinegar
bitter	strength
dry	wine
sweet	poison/juice/find treasure
<b>Silver</b> bitter	poison/intelligence
plain	heal major wounds
sweet	charisma
<b>White</b> alkaline	poison/milk
bitter	slowness
salty	heal all wounds
<b>Yellow</b> bitter	noticeability
dry	weakness
plain	healing wounds

**LURKING HORROR** – hints by **Ian Houghton**

To clear the rubbish away from the storage area just near the basement you use the forklift.

To lift the manhole cover in the ancient storage you use the crowbar to prise it open.

To get rid of the maintenance man and get to the alchemy lab you must search the infinite corridor until you find a glass cabinet. Smash the cabinet with the crowbar and get the fire axe. Also get floor wax. Go to the power cord which is connected to the floor waxer and pour the wax onto the floor. Cut the power cord with the axe then wait as the maintenance man attempts to get to you through the floor wax. Eventually he will die.

**GUILD OF THIEVES** – hints

To get down the thin shaft dig in sand then wear boots (you need the lamp).

Break the window to enter undertaker's shop. Lift flap to get past counter and press button to open the till.

If you keep getting buried you are hanging around too long.

Tell the mynah bird something to get it to talk.

To get rid of the spider open the jam jar in the stable, close the jar then throw jam at spider.

The finger bone unlocks the sarcophagus.

**CHRONOQUEST** – by **D.G. Lyndon**

**Prehistory**

Hut – look then get bone and dry grass (ignore stone)

Stream – east quickly!

Fire – use grass on fire, light lighter then light fire. get burning branch then drop lighter and get stone.

Chamber – look skull then get part of punch card, look drawing.

Hut – drop lighted branch then return to machine and pull switch.

Library – drop bone and stone then get bottle.

Machine – up, pull switch then use first from left punch card in slot.

**India**

Leper – use gloves on his hand, get sanskrit note.

Square – use sanskrit note on keeper.

Temple – use bottle in pool.

Leper – use water on leper's hand then get key.

Machine – use key in keyhole.

Table – look envelope then pick up letter and piece of punch card. Drop letter (no use).

Fakir – get scroll (by left knee).

Machine – pull switch.

**INDIANA JONES & THE LAST CRUSADE** by **John**

**Beranek**

**University**

First enter your office after talking your way through the students. Take all the junk mail then



The Nazis are up to no good in Indiana Jones – The Graphic Adventure

the package and open it. Leave through the window. After meeting Donovan go to Henry's house and take the painting then go to Venice.

**Venice**

At the restaurant look at the wine bottle then take it. Enter the library. Take the Mein Kampf in the bookshelf which is not completely filled (you would have to search for the correct shelf). At the stained glass window look at the Grail Diary.

Note the picture of the window that is drawn in the diary and the statement (first on the right etc). Press ENTER and leave the area. Search the place for the metal post and then take it. Search the library for the stained glass window which matches the one in the diary.

Look at the pillar corresponding to the statement in the diary, either left or right. Using the post open the slab represented by the inscription on the pillar (first on the right means the first inscription on the right pillar). Climb in to enter the sewers.



With our tips, you too can be as tough as Harrison Ford



In the Library Indy may find the most valuable book is his diary

**Skulls**

In the Grail Diary there is a part about the skulls in which the higher note in the diary corresponds with the skull with the higher tone. With this you can easily play the correct tune to enter the knight's tomb. The tune changes for each game so if you've missed the tune you can enter the room again to hear the tune again. After opening the casket and looking at the remains of the knight, move forward. Pull the rusty lock and exit the sewers through the manhole. Now for Castle Brunwald.

**Castle Brunwald**

After getting past the butler enter the north passage. Meet the drunken guard and either by talking or fighting take his stein. Go to the room where the keg of ale is and where the roast boar is cooking. Fill the stein with ale then pour it all over the roast boar. Take the roast boar and refill the stein. Leave and enter the east passage. Search until you find the servant's uniform. You can bypass most of the guards by talking using different phrases of speech.

Go to the second level and find the brass key. Go down to the area where you found the servant's uniform. Unlock the grey uniform and wear it. Go back up and head for the southwest corner where the soldier guards the art area. Give him the painting then search the rest of the area until you find a first-aid kit. Enter the alarm room in the northwest corner and give the guard the Mein Kampf. Go upstairs to level three.

Enter the first room and give the roast boar to the dog. Take the trophy, open the file cabinet and take the pass. Go back down to the art section. Push the Mona Lisa, enter the vault and look at the painting. Leave and go back down to the keg of ale. Fill the trophy with ale. Back to level three, give the trophy to the Nazi then hit him. Take the southern corridor and talk your way past Sigfried the officer and say that you're new. Enter

the last room and take the silver key. Return and take the northern corridor. Go to the second door, use the silver key, enter and open the window on the right. Open the cabinet to find some money. Open the door. You will be captured. To get more money you can fight the guards and steal their money.

**The Escape**

Get Indy to pull and Henry to push the chair until you get to the suit of armour. Push it and the axe will slice the rope. Push the statue, go out and take the motorcycle. At the check points you should select the third phrase then say that you are on a secret mission and that you have no ID. The guard will let you pass. At Berlin, after retrieving the diary, offer Hitler the pass. At the airport buy the tickets for the Zeppelin if you have enough money, otherwise go outside and enter the bi-plane and take off. This way you bypass the Zeppelin.

Give the tickets or talk your way past the ticket collector. Get Henry to go to the piano and put coins in the bowl. Let Indy stand outside the locked door. When the German leaves the room open the locker and take the wrench. When he returns use the wrench in the hole. Then climb up the ladder. You're now in a maze and must find your way to the bi-plane. To do that, go up several levels then east and then down again. After finding the bi-plane and getting shot down, use the car to get out of Germany. At all guard posts give the pass to the guard. You will eventually end up at the temple.

**Temple**

In the first test near the location of the corpse and above rocks, you will see two areas, split apart on both sides by lines. Walk to the area on the right and you'll pass the blades. For the second test you must get to the other side of the cavern. The only safe tiles are the ones used to spell the god's name. This name is different from game to game. For the third test you should move the pointer to the outcrop of rock jutting out above the opposite tunnel entrance and walk there. Now you should cross safely. Lastly, choose the brass chalice with the Greek inscriptions. After Elsa dies, look at the broken seal, use the whip with grail and give the grail to the knight. When the temple is destroyed, leave and you have won!

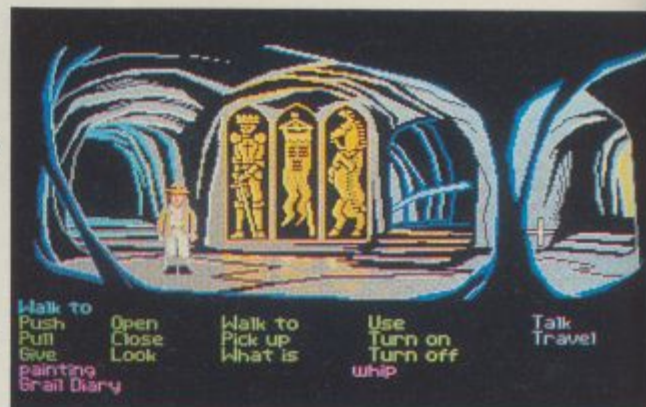

Indy discovers that chivalry is not dead in the Catacombs

# THE 1990 ATARI ST PRODUCT GUIDE

## PERIPHERALS & ACCESSORIES



FLOPPY DISK DRIVES



MONITORS



JOYSTICKS



SCANNERS

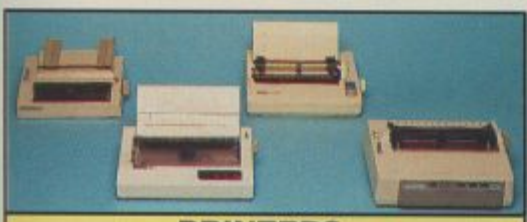

PRINTERS



DISK BOXES



ROBOTICS

**PLUS MUCH MORE!**  
SEND FOR YOUR FREE PRODUCT GUIDE!

## THE UK's No 1 GUIDE TO THE ATARI ST

# AND ITS FREE!

If you are interested in buying an Atari ST (or if you already own one), then you will not want to miss the FREE Atari ST Product Guide from Silica Shop. This 48 page, full colour guide is packed with details of peripherals, accessories, books and software for the Atari ST range of computers. In fact, the 1990 Atari ST Product Guide is the most comprehensive product handbook available for the Atari ST. Not only does the Product Guide provide an invaluable source of information on the UK's largest range of ST products, it is available absolutely FREE OF CHARGE! Just complete and return the coupon below for your FREE COPY! In addition to ALL Atari hardware, the range of products featured in the catalogue includes:

### PERIPHERALS:

Robotics	Clocks	Floppy Disk Drives
Hard Disk Drives	Emulators	Graphic Tablets
MIDI/Music	Modems	Modulators
Monitors	Mouse controllers	Plotters
Printers	Scanners	Scientific Equip
Sound Digitisers	Sound Samplers	Video Enhancers

### ACCESSORIES:

Cables	Cleaning Kits	Disks
Disk Boxes	Dust Covers	Joysticks
Monitor Access	Mouse Access	Power Supplies
Printer Labels	Printer Paper	Printer Ribbons
Stands	Upgrades	

### BOOKS:

ST Dedicated    68000 Processor    General Computing

### SOFTWARE - ENTERTAINMENT:

Arcade Games	Compilations	Advanced Sims
Sport Sims	Adventures	Board & Strategy

### SOFTWARE - PRODUCTIVITY:

Art & Graphics	Accounts	CAD
Communications	Databases	Desktop Publishing
Education/Childs	Music	Programming
Spreadsheets	Utilities	Word Processors

## SOFTWARE & BOOKS



ARCADE GAMES



ART & GRAPHICS



EDUCATIONAL



MUSIC



BOOKS

**& STILL MORE!**  
RETURN THE COUPON NOW!

**COMPLETE & RETURN THE COUPON FOR YOUR**

# FREE COPY

**OF THE 1990 ATARI ST 48 PAGE PRODUCT GUIDE**

FROM SILICA SHOP - THE ATARI SPECIALISTS

Silica are the UK's No 1 Atari Specialists. We have been established for over 12 years, and have an annual turnover of £10 million. With our experience and expertise, we can claim to meet our customers requirements with an understanding which is second to none. But don't just take our word for it. Complete and return the coupon for our latest free literature and begin to experience the "Silica Service".

**SILICA SHOP**

**MAIL ORDER:** 1-4 The Mews, Hatherley Rd, Sidcup, Kent, DA14 4DX Tel: 081-309 1111  
Order Lines Open: Mon-Sat 9.00am-6.00pm No Late Night Opening Fax No: 081-308 0608

**LONDON SHOP:** 52 Tottenham Court Road, London, W1P 0BA Tel: 071-580 4000  
Opening Hours: Mon-Sat 9.30am-6.00pm Late Night: Thursday until 8pm Fax No: 071-323 4737

**LONDON SHOP:** Selfridges (1st Floor), Oxford Street, London, W1A 1AB Tel: 071-629 1234  
Opening Hours: Mon-Sat 9.30am-6.00pm Late Night: Thursday until 8pm Fax No: 071-495 8321

**SIDCUP SHOP:** 1-4 The Mews, Hatherley Rd, Sidcup, Kent, DA14 4DX Tel: 081-302 8811  
Opening Hours: Mon-Sat 9.00am-5.30pm Late Night: Friday until 7pm Fax No: 081-309 0017

To: Silica Shop, Dept ACE-0790-37, 1-4 The Mews, Hatherley Rd, Sidcup, Kent, DA14 4DX

**PLEASE SEND ME A FREE ST PRODUCT GUIDE**

Mr/Mrs/Ms: ..... Initials: ..... Surname: .....

Address: .....

Postcode: ..... Tel: .....

Which computer(s), do you own? .....

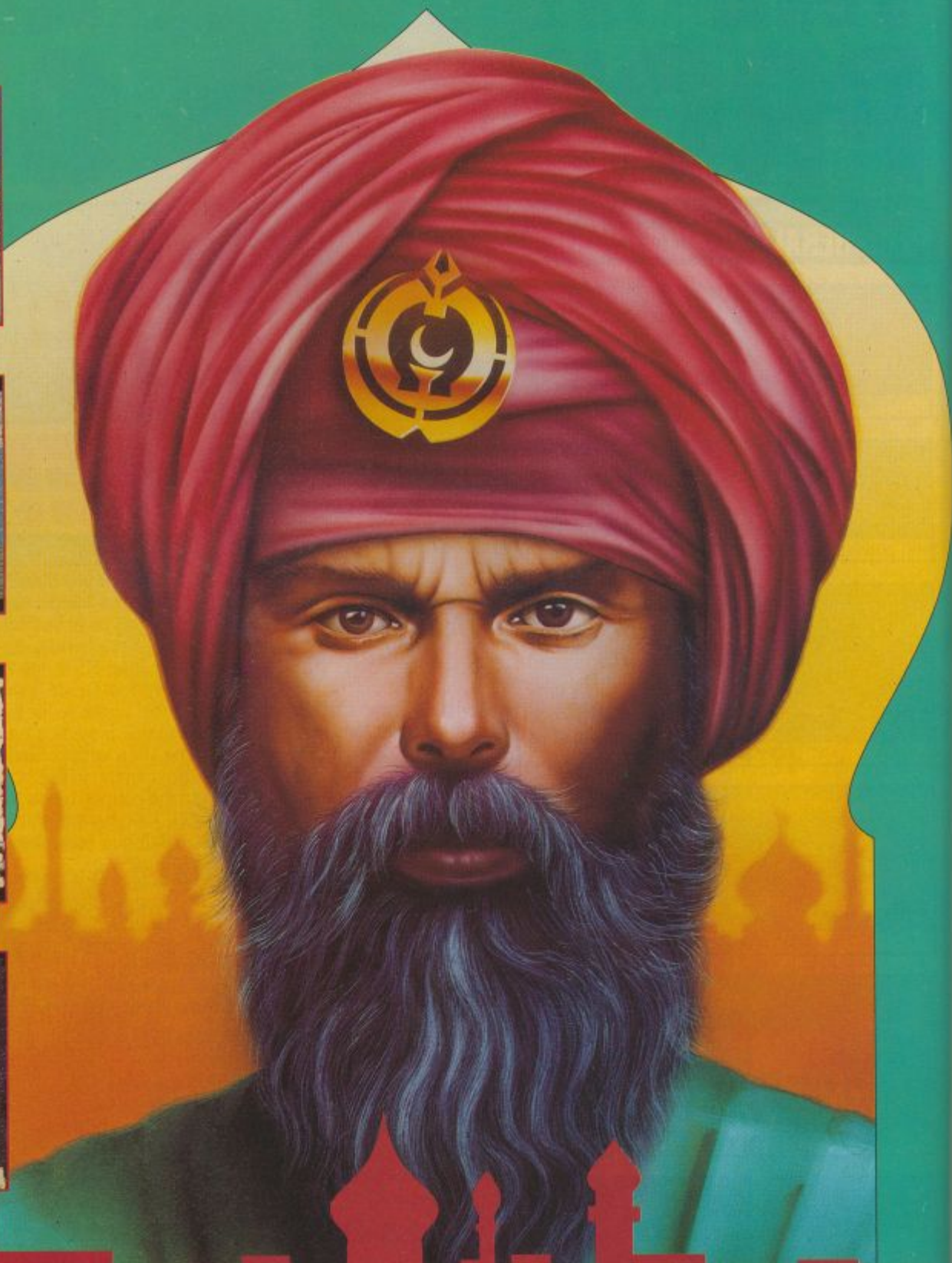

# Khalaan



*Be spellbound. Let Khalaan enchant you. Adventures, dangers, intrigues and secrets await you in the mystical world of the Orient.*

*As one of four Caliphs you covet the throne of the Great Caliph, supreme ruler over all land and life. The army obeys your every whim, your ships ply the oceans, your caravans range far and wide, carrying exotic goods to your country's markets. You decide between war and peace .....*

*Khalaan is a complex strategy simulation. All actions are simulated in real time. You have also got an options menu at your disposal with which the skill level can be adjusted to suit your requirements.*

- "PHOTOREALISTIC" graphics and animation
- Five gripping action sequences, one in 3 D
- Mouse, joystick or keyboard controls
- And let's not forget the atmosphere of "Arabian Nights".





## DRAKKHEN

### The Complete Guide Part One THE GAME WORLD

The Drakkhen world is a mysterious island, made up of four equally sized temperature zones; Artic, Marshy, Temperature & Desert. Each zone contains road systems of varying complexity, an Anhak temple of healing, two palaces and a portal or two, as well as dwelling places in the style of the local inhabitants (from whom information can usually be gleaned, although this varies in relevance). You will also meet, in certain places on the road system, old men who absolutely insist on giving you information which may or may not concern your quest – they may be annoying, but are actually quite dangerous awhile your characters are at low levels, so avoid the temptation to slice them up into dragon fodder.

**When you begin the game**, make sure you have generated a good, balanced group of characters – all containing high scores in their primary stats; this may take some time and can be tedious, but it is almost essential if you want to get anywhere in Drakkhen. The best groups are ones which contain one character from each profession.

Upon entering the game world you should immediately outfit your characters. They all possess certain items to begin with, and these help increase your protection level. The next thing you should do is turn east and enter the Palace of Prince Hordtkhen, as the world outside is a very dangerous place for novice adventurers.

Wait until the sharks fin has passed under the drawbridge and started to move to the right before trying to enter, or you might find yourself with one less character before you've begun. Once in the palace, switch off the force field by moving a character towards the symbol between the two doorways facing you, and selecting 'operate'. Then, using your warrior and scout first, start to explore.

There are loads of different enemies around, and plenty of equipment to pick up and use. Avoid going upstairs at the beginning, as you will come across enemies who can easily defeat you at this point. It may take time, but you should be able to raise some of your characters a few levels after a bit of hacking and slashing – protect your magic users until their levels have improved substantially, because they are more or less vital.

**Hot Tip:** To gain experience quickly after you've already risen a level or two, reenter Hordtkhen's Palace and operate the wrong symbol. This causes two Hunchback guards to enter. Kill them, and repeat the procedure until you get bored; always remembering to heal any wounded characters after each skirmish.

**When you have risen a few levels** you should leave the palace and save the game, just in case something happens to undo all your good work. It is a good habit to save your game regularly, as you will almost

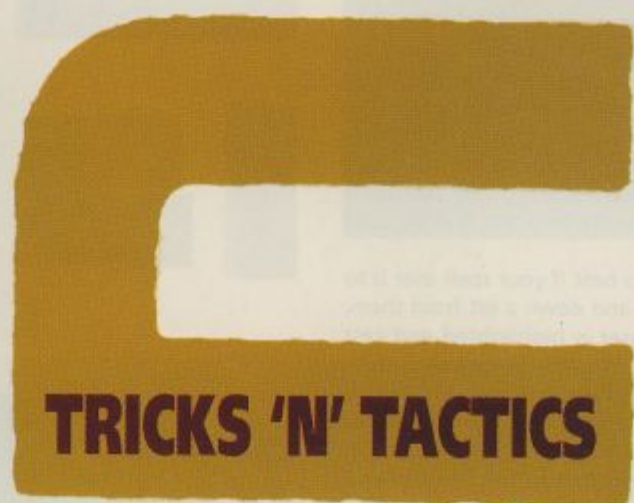
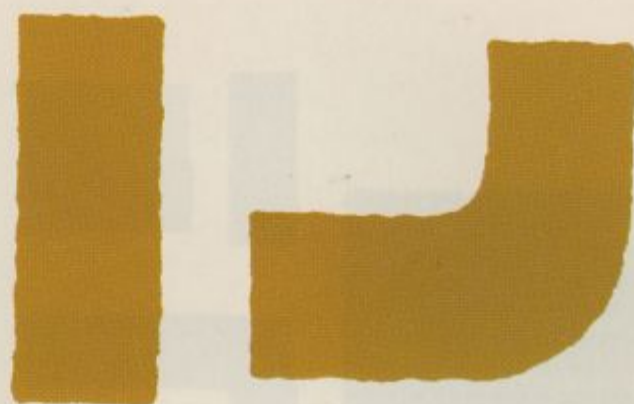

## TRICKS 'N' TACTICS

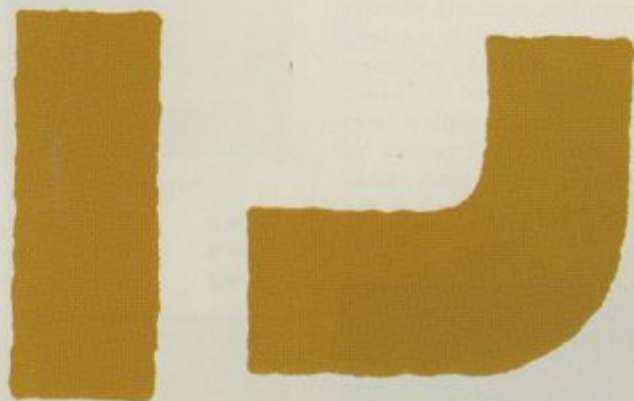

Hints and tips on the latest blockbusters. The easiest and best, nay finest way to tame your game.



This month we begin two great new serials. First, a complete guide to Drakkhen from Adam Morley –

the man who brought you superlative solutions to Battletech and Batman.

Then, as so many people seemed to enjoy the Dungeon Master guide we have similar fare for its futuristic counterpart, Xenomorph, from ACE explorer Alan Coates.

Budding C64 hackers can also get stuck in to the second part of Jon's guide to the art of C64 cheats.

certainly die with an irritating frequency. Games can only be saved outside of palaces and temples, so save before you go in and also when you leave.

You may feel like taking a stroll through the countryside now, but be careful, as the creatures you will meet out here are dangerous (with the exception of the packs of killer rats which may threaten to overwhelm your ankles, but little else). Orientation in the game world has proved difficult for some people, but if you remember that the sun rises in the east and sets in the west you shouldn't have too many problems; except when you can't see it of course!

**It is wise to stay out of the Desert Zone** until your characters are well equipped and fairly strong, because it is the most hazardous of all the zones, and contains many creatures which kill you in an instant. The Artic zone is also quite dangerous, but you may wish to make a visit or three to the swordsmiths there to buy and sell equipment. In general, however, it is

best to stick with the Marshy and Temperate zones until you feel like attempting the quest proper.

**At first most of the armour you find** will only be suitable for your warrior and scout, but eventually you will find pieces that your magic users can wear. The sorcerer usually wears the grey and orange cuirass and greaves obtained from dead Drakh Knights; those with orange cloaks. While your priest wears the golden cuirasses (the ones with the large shoulder pads) and greaves, found after slaying some of the more exotic creatures. You can guarantee that the larger and more powerful the creature you slay, the better the equipment that you find will be.

One of the main features of the game is the magic system, which must be mastered quickly if you wish to progress very far. At first your magic users will have fairly limited power, but this rises quite quickly as the character levels improve. Both the sorcerer and the priest can use a healing spell to replenish hit points, and this will be used often.

Application of the spell works best if your spell user is to the left of the target character and down a bit from them. Make sure the correct magic user is highlighted and cast the spell by aiming the cursor at the target and then clicking on the right-hand mouse button. If the spell has no effect, try repositioning one, or both of the characters involved. The shield spell (number 7) is also useful in protecting the magic users, and can be used from level 2 onwards.

**While travelling in the game world** it is possible to escape attack by pressing the return key just before or just after your foe appears – however, this approach doesn't help improve your characters' experience and, in the long run, it may not be such a good idea (unless you are about to be fried by a dragon). Injured characters can be healed, for a price, at any of the Anhak Temples; although it takes quite a bit of money to convince the priest to bestow his blessings on your blood spattered warrior and scout – dead characters may be resurrected here if you have the necessary ship-load of Jade.

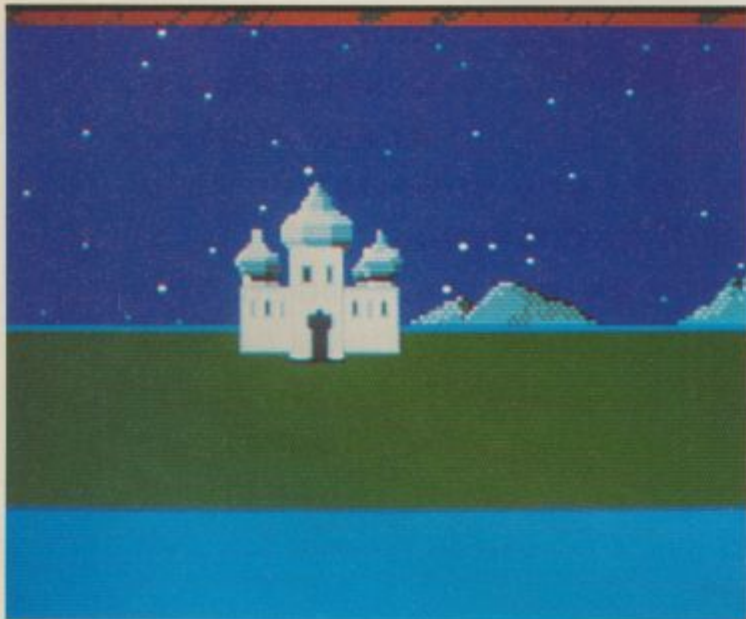

Apart from the ubiquitous "Old Men", you can also gather information from the houses scattered about, and more directly from the Inn, situated SW of Hordtkhen's palace (although you need rather a lot of Jade pieces to get the juiciest bits).

Rather a neat little aid to help your foot-sore characters get around are the well-scattered portals which transport you across great distances at headache inducing speeds. Portal 1 – shown on the map – takes you to portal 6. Portal 2 takes you to Portal 3, & Portal 4 takes you to Portal 5 – and vice versa in all cases.

**One final warning** about travelling in the Temperate zone (where you begin). Do not attempt to pass through the firestones at the centre of the zone unless you have strong characters, or unless they are armed with bows,



because it is a place heavily occupied by rather large, dangerous dragons who like nothing better than to land on innocent adventurers like yourself.

Next month Adam will be back with more maps and playing tips for Drakkhen.

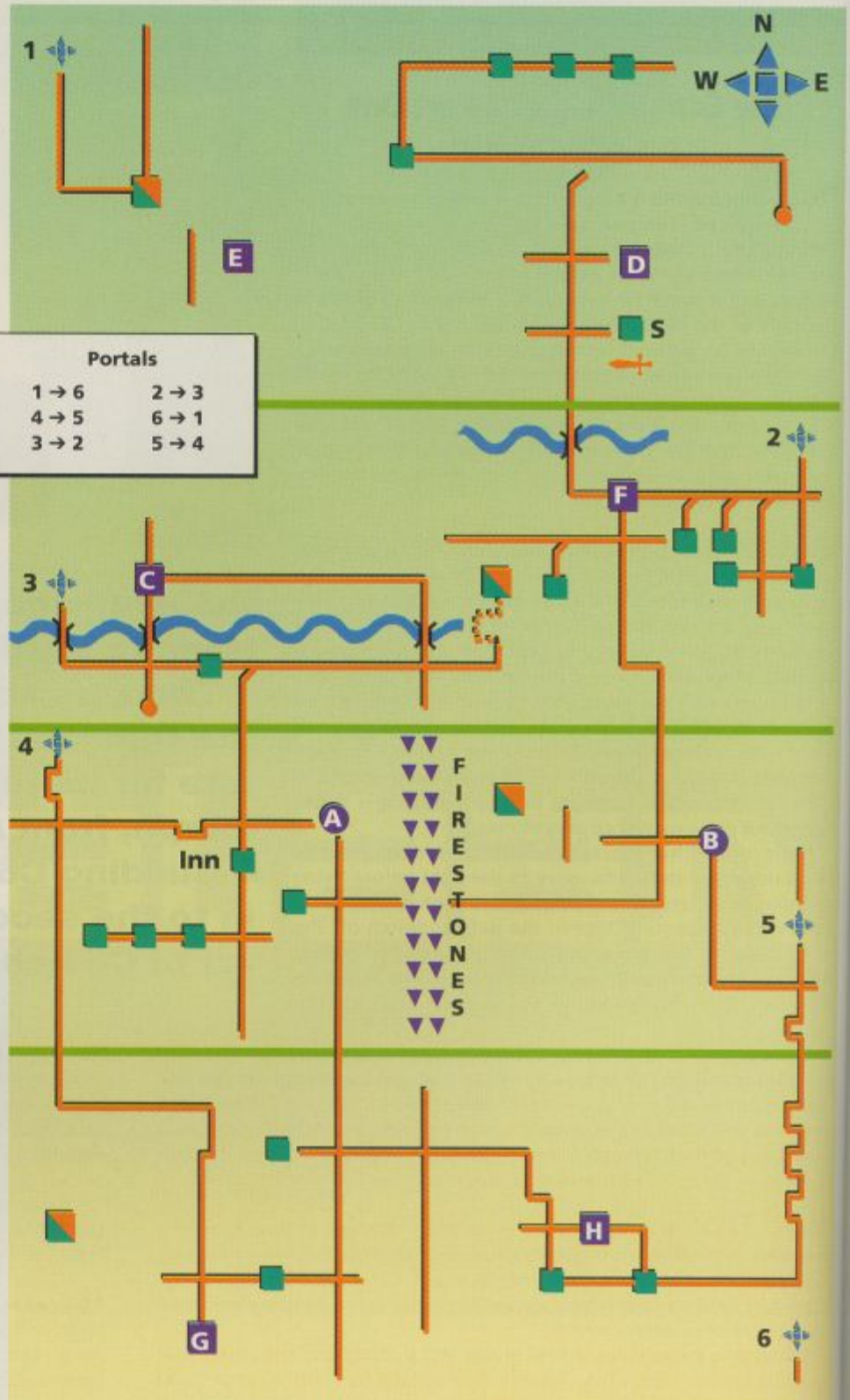



## XENOMAPS!

Here is the first of a series of maps for adventurers feeling a little lost in Pandora's Xenomorph, courtesy of Alan Coates.

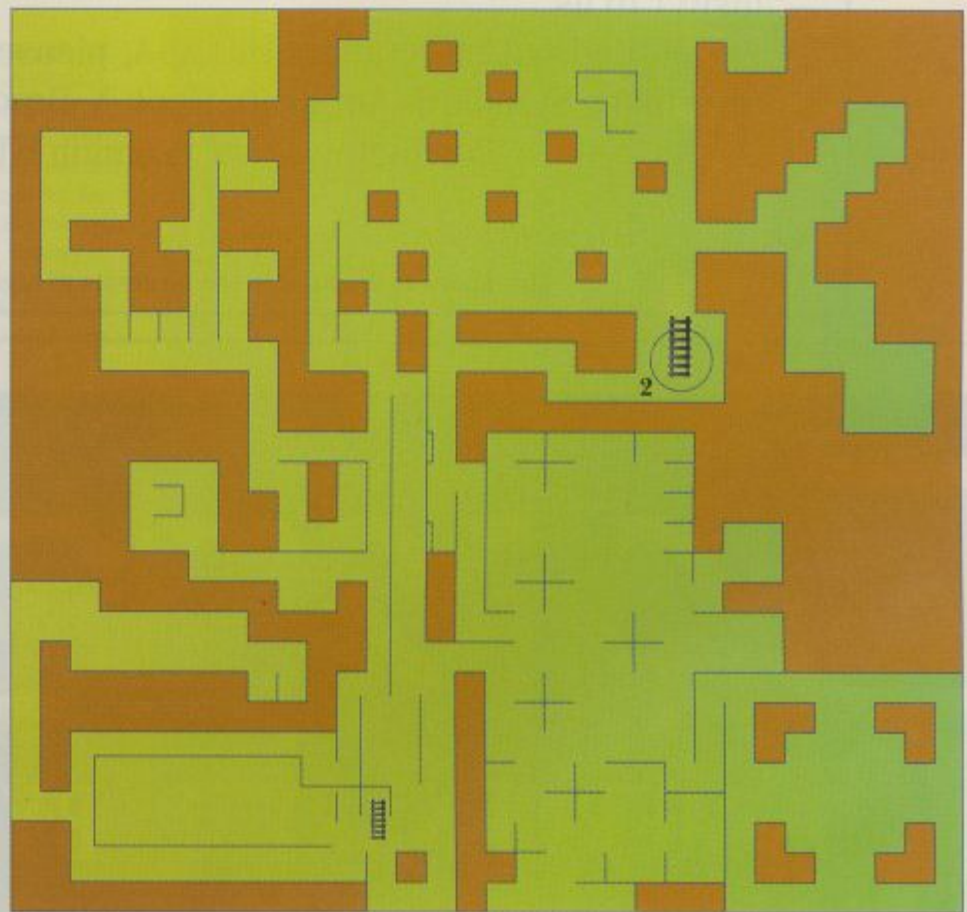
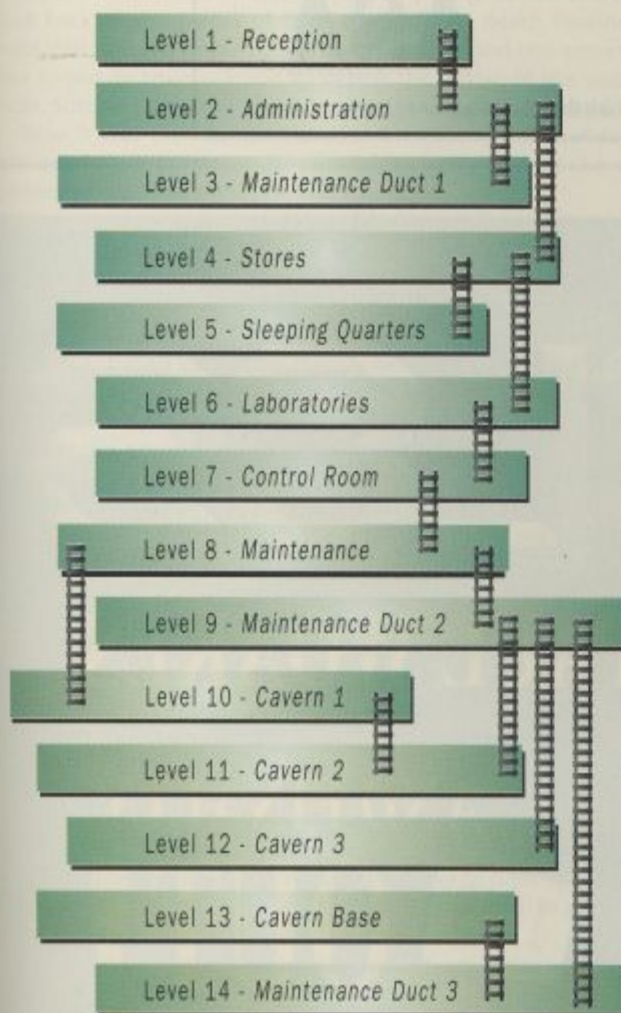

## TNT SURVIVAL GUIDE - C64

This month we continue our TNT Survival Guide with more hacking hints from our C64 master, Jon.

Most people who read games magazines are used to keying in pokes from the cheat section, few have more than a vague idea how they work.

Over the next few months I hope to explain some of the things that go into writing a good cheat mode and will try to give you a clear idea of how they work, without getting too technical. There is also a finished listing for you to type in and use yourself. If you already write your own cheats, don't skip this part of the magazine, there are things here you might need to know, like how to write a cheat that doesn't require a reset of the machine.

This month's cheat is for Bombuzal.

For Bombuzal I wanted immunity to all the different ways of dying, the removal of the 'Don't Stand Still' warning, and the ability to skip levels by pressing the space bar.

Tracing the game's code right through would be an onerous task, but is fortunately totally unnecessary. Let's take immunity: when you die you lose a life, so we need to look



# IF AN ADVERT IS WRONG, WHO PUTS IT RIGHT?

We do. The Advertising Standards Authority ensures advertisements meet with the strict Code of Advertising Practice.

So if you question an advertiser, they have to answer to us.

To find out more about the ASA, please write to Advertising Standards Authority, Dept. X, Brook House, Torrington Place, London WC1E 7HN.



This space is donated in the interests of high standards in advertisements.

# DAMOCLES

## IS MERCENARY II BY PAUL WOAKES

AND FINALLY

**IT IS OUT!  
NOW!**

FOR ATARI ST & COMMODORE AMIGA £24.95

# NOVAGEN

Copyright © 1990 Novagen Software Ltd 142 ALCESTER ROAD BIRMINGHAM B13 8HS 021-449 9516

for some code which decreases your lives. The byte that is decremented will, of course, reflect the number of lives you have left.

Once I had found infinite lives, I began to look for an immunity poke. It turns out that your lives are decreased immediately before the 'Get Ready' message. Tracing the code backwards to find the conditional branch that forms the link to the death sequence might have taken some time. (A conditional branch is a machine code instruction that will only jump to a piece of code if a certain condition is satisfied, otherwise the program will just continue with the next instruction.)

I found the location of the flag that indicates whether or not the player should lose a life. There were two pieces of code that used this location to kill you. One of them turned out to be connected to the timer, and the other is for all the other ways of dying. Death from timer expiry is accompanied by a sound effect, so I soon found the address of the sound effects generator (very useful). The effect, and the two routines were then removed. Starting the game again confirmed that I could not now be killed.



**Sometimes protection against death** can be problematic. If, for instance you get stuck in a place you cannot get out of then you'll have to reset. On this occasion Sinister and Dexter, who normally kill you when you come into contact with them, passed harmlessly but exploded with every pixel of movement, slowing everything down. The answer was to look back at the pieces of code that call the death routine. Looking for code that jumped to the non-timer deaths I found one occurrence. I merely had to put in an instruction to bypass the whole of the suspect section of code. Success – now the twins can be passed safely and quickly.

Now it was time to get rid of the tiresome time-out sound. This was achieved by systematically removing every call to the sound effects generator until the right one was found.

Next on the hit list was the 'Get Moving' warning and the tedious spinners. Here's one of those occasions when knowing the address of the sound effects generator comes in handy. As with the time-out sound I systematically checked calls to the generator until I'd found the right one. The routine which checks whether the warning needs to be sounded was, of course, based upon the length of time you spend without moving. Bearing this in mind I swiftly found the location holding the length of time you remain still. Rather surprisingly it's value counted up and not down, and was not equal to the value of the counter you see if you hang around for too long. Removing this process seemed to do the trick.

A few minutes of play later and I'm beginning to run into problems. I've destroyed all the bombs, but the game won't let me progress to the next level. Of course, to get to the next level you must also be standing still, but the program believes that I'm still moving because of the cheat I installed earlier. The answer, in cases like this is to reverse the problem - I just 'tell' all the relevant sections of the program that I am always standing still.

**All that remains to be done** is install a hot key to allow you to skip levels. I chose the space bar because it already has an in-game 'quit' function. The first step was to search for programmer Tony Crowther's own space bar check. The obvious method (replacing the programmer's routine with my own), didn't work - I got the time bonus, but no look at the completed level. I suspected that the program was occasionally jumping right into the middle of the replaced routine (a right recipe for a complete crash), and I was right. Relocating my own routine to safer memory soon saved the day.

As a final exercise I decided to find out what the level passwords were by looking them up in memory. A search through the whole of the C64's available RAM turned up nothing that remotely resembled a password. OK so the programmer has encrypted them all – we can handle that. This sort of problem requires a bit of lateral thinking. I went into the password entry mode and calculated the screen addresses that the password is written to. By looking for code which checked these addresses I managed to locate the section of the program that checks for the correct code. The encryption was achieved by doubling the ASCII value of each letter and performing a logical NOT on every other bit. The reward for this effort were the passwords to all 256 levels (even though they haven't all been implemented).

Right, here's the listing. Next month I'll be back with more info for budding C64 hackers.

```

10 REM +* BOMBUZAL CHEAT: BY JON *+
20 F=90
30 FOR X=17384 TO 17695: READA$: L=ASC(RIGHT$(A$,1)): IF L>64 THEN
L=L-7
40 L=L-48:
H=ASC(LEFT$(A$,1)):
IF H>64 THEN H=H-7
50 H=H-48: P=H*16+L: POKE X,P: POKE 53280,P: D=D+P: Y=Y+P
60 C=C+1: IF C=8 THEN READ A: Y=Y+A: F=F+10: C=0: IF D<>A THEN
PRINT "ERROR: IN LINE ";F: END
70 IF C=0 THEN D=0
80 NEXT X: IF Y<>71328 THEN PRINT "ERROR: UNKNOWN LINE": END
90 POKE 53280,14: PRINT "PRESS A KEY WHEN READY.": WAIT 198,1: SYS
17384
100 DATA 78, A9, A0, 85, 35, A9, E0, 85, 1161
110 DATA 37, A0, 00, 84, 34, 84, 36, 8C, 725
120 DATA 11, D0, B1, 34, 91, 34, 8D, 20, 824
130 DATA D0, B1, 36, 91, 36, 8D, 18, D4, 1015
140 DATA C8, D0, EF, E6, 35, E6, 37, D0, 1423
150 DATA E9, A9, 35, 85, 01, A2, 44, A0, 979
160 DATA C2, 8C, A9, FC, 8E, AA, FC, 88, 1455
170 DATA 8C, B1, FC, 8E, B2, FC, A9, 60, 1406
180 DATA 8D, E0, E4, A2, 44, A0, 58, 8C, 1214
190 DATA 14, 03, 8E, 15, 03, A2, F4, A0, 755
200 DATA A5, 8C, 30, 03, 8E, 31, 03, A9, 719
210 DATA FE, 8D, 20, D0, A9, 1B, 8D, 11, 989
220 DATA D0, 4C, 56, F5, A9, 37, 85, 01, 973
230 DATA A2, EA, A0, 31, 8C, 9F, 02, 8E, 1048
240 DATA A0, 02, 60, E6, 35, A5, 35, 29, 800
250 DATA 07, F0, 03, 4C, 31, EA, A2, 44, 839
260 DATA A0, 77, 8C, E9, 02, 8E, EA, 02, 1032
270 DATA A9, 37, 85, 01, 4C, 51, 03, A2, 680
280 DATA 44, A0, 84, 8C, CE, 01, 8E, CF, 1056
290 DATA 01, 4C, 81, 44, A2, 44, A0, 91, 809
300 DATA 8C, 63, 46, 8E, 64, 46, 4C, EB, 932
310 DATA 02, 78, A9, 00, 85, FE, A2, 17, 863
320 DATA BD, C3, 44, BC, DB, 44, 85, FF, 1315
330 DATA BD, F3, 44, 91, FE, CA, 10, F0, 1357
340 DATA A2, 06, BD, 0B, 45, 9D, 8B, 30, 781
350 DATA CA, 10, F7, A2, 0C, BD, 12, 45, 915
360 DATA 9D, B5, 30, CA, 10, F7, 4C, 00, 927
370 DATA 30, 5B, 44, 15, 15, 15, 15, 1F, 322
380 DATA 1F, 2C, 2E, 2E, 2E, 2E, 2E, 351
390 DATA 2E, 80, 80, 80, 80, 82, 82, 82, 948
400 DATA 82, 87, A6, 42, 49, 70, 91, DB, 1046
410 DATA E2, 39, 10, 12, 13, 14, 15, 2D, 422
420 DATA 7B, 46, 47, 50, 51, B9, BA, BF, 987
430 DATA C0, BF, 90, AD, AD, 1A, 0A, AD, 1082
440 DATA AD, A9, A9, 8D, 22, 21, 60, 1A, 841
450 DATA AD, 00, FD, 00, FD, 00, FD, 00, 932
460 DATA FD, 4E, AD, 20, 43, 48, 45, 41, 809
470 DATA 54, 20, 20, 41, 43, 45, 20, 52, 463
480 DATA 45, 41, 44, 45, 52, 53, 21, 00, 469

```

# Battle Masters™

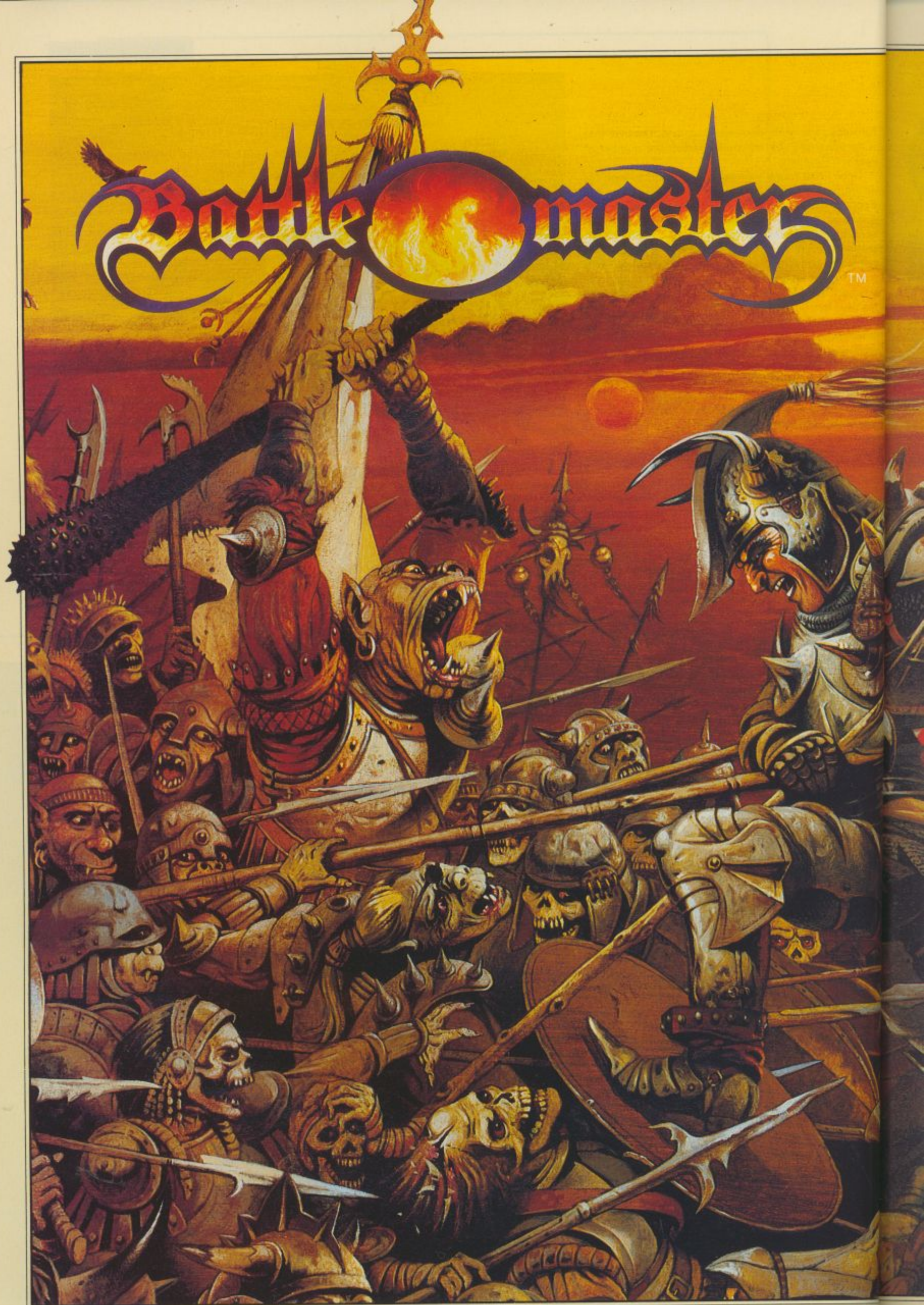

# A TIME of MISERY, A TIME of BLOOD

*'A hero is coming from the south who will conquer the four kings of this sorely troubled land. And amidst the bloodshed and magic, the clash of shield and the glint of steel, the seeds of peace will be sown. When the battle is over a new age begins.'*

FOR AS LONG AS ANYONE CAN REMEMBER, ORC, ELF, MAN AND DWARF HAVE BEEN LOCKED IN TERRIBLE COMBAT; THE LAND IS A DESOLATE WILDERNESS REEKING OF DEATH AND DECAY. BUT THE WATCHER HAS PROPHESIED THAT THE AGE OF CONFLICT WILL END WHEN THE CROWNS OF THE FOUR FEUDING KINGS ARE WON AND BROUGHT TO THE TOWER.

BATTLEMASTER TAKES THE FANTASY ARCADE ADVENTURE INTO A TOTALLY NEW DIMENSION. SURVIVE HAIR-RAISING ENCOUNTERS WITH FEROCIOUS MONSTERS, NEGOTIATE TO BUILD UP YOUR OWN PERSONAL ARMY AND BECOME A MASTER OF THE MAGIC ARTIFACT. FEATURING HIGHLY DETAILED MAPS, PACKED WITH PUZZLES, DRAGON AND POTIONS, AND INCORPORATING UNIQUE FIGHTING STRATEGIES, BATTLEMASTER OFFERS THE ULTIMATE CHALLENGE.

*War creates many heroes, but there is only one BATTLEMASTER.*



DESIGNED BY MIKE SIMPSON, GAME CONCEPT OF THE YEAR AWARD WINNER.  
AVAILABLE SOON ON AMIGA (£29.99), ATARI ST (£24.99), IBM PC & COMPATIBLES (£29.99).  
SCREENSHOTS, ATARI ST VERSION, ILLUSTRATION AND LETTERING, CHRIS ACHILLOS.



PSS, IRON HOUSE, 118 SOUTHWARK STREET, LONDON SE1 0SW, TEL: 01 928 1454  
© 1990 MIRRORSOFT LTD.

SAVE MONEY!

**12**

**ACE ISSUES  
FOR ONLY £17.95**

- 12 issues from your newsagent would normally cost you £19.20
- Receive free quarterly issues of InterFACE – an exclusive subscriber's newsletter



- Don't queue for your copy!
- Receive **priority allocations** at ACE conferences\* and get **free tickets** (non-subscribers pay £5).

\*Attendance limited.

**Guarantee**

If you aren't completely satisfied with your subscription, you may cancel and receive a prompt refund for all unmailed copies.

Overseas subscriptions (12 months) Air Mail Europe £42.95 ● Air Mail Rest of World £72.95  
● Surface Mail All Territories £27.95  
just fill in the form below or call **0858 410510**  
credit card hotline **0858 410888**

**PLACE YOUR ORDER**

To subscribe the ultimate games magazine just complete the coupon below, or send your details on plain paper, or ring our special 24 hour Orderline service on 0858 410088 and quote your credit card number.

To: ACE Subscriptions Department, PO Box 500, Leicester LE99 0AA.

Name.....

Address.....

.....Postcode.....

Please start my subscription from the  enter month issue of ACE. I enclose my cheque/postal order (payable to ACE MAGAZINE) for £

Please charge £  to my Access/Visa/Diners Club/American Express account. Card Number

Expiry Date

Signature.....

We suggest that overseas readers pay by International Money Order. Other airmail rates are available on request. For subscription enquires telephone 0858 410510.

**THE ACE**

The future of electronic entertainment has never looked better – and neither has the magazine that's universally acknowledged as THE most authoritative magazine covering games technology. People who read ACE regularly know that they will always be kept right on the cutting edge of the entertainment revolution. If you haven't been getting the mag regularly, here's what you've been missing – and this is just the last four issues!

**EXCLUSIVE COVERAGE**

CD-I Batman, Ultima VI, the revolutionary Microprose arcade flight simulator, hypergames, Sid Meier's superbly playable Railroad Tycoon, location reports from US companies, Centurion – the successor to Defender of the Crown, and much more – all covered FIRST in ACE.

**IN-DEPTH REVIEWS**

The ACE PIC curve system is unique – no other

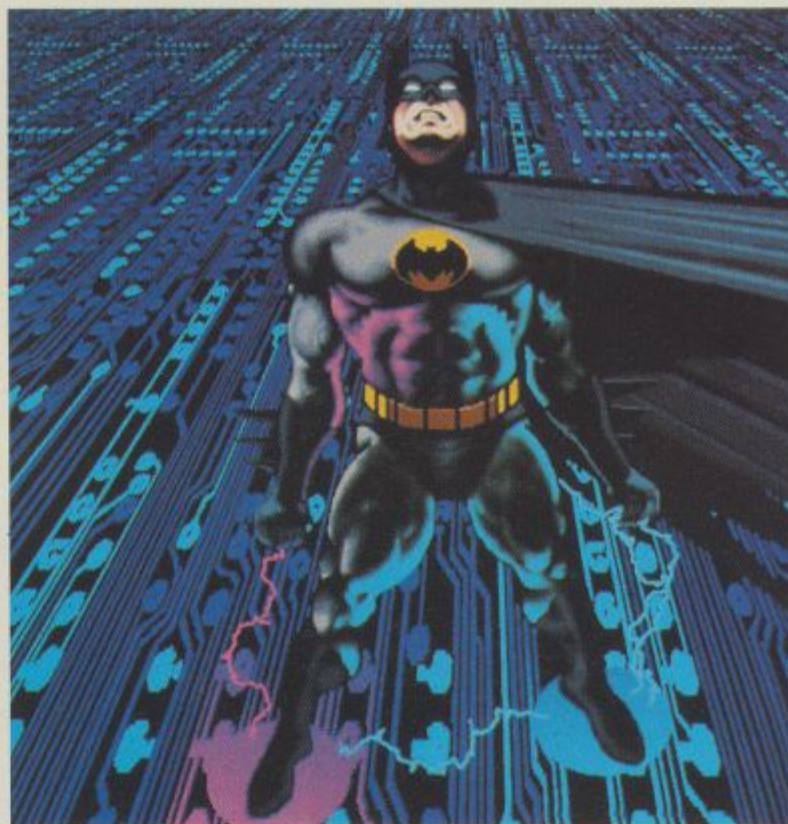

Batman on CD-I – you saw it here first!

**EXCLUSIVE  
to subscribers**

**ACE CONFERENCES**

ACE isn't just a magazine – it's also a communications link between you, the readers, and software houses. We've set up a series of ACE conferences in which subscribers to the magazine are given the opportunity to meet software houses and talk to them about their games (and you don't have to be polite either!) on an informal basis. Lunch is supplied and admission is free to subscribers, who will also receive priority



# CLUB



Centurion – Electronic Arts' Roman conquest scenario, from the designer of Defender of the Crown and exclusively in-depth previewed in ACE

reviewing system tells you more about the games you're going to play. What's more, unlike many other magazines, ACE ONLY reviews the finished versions of games, not demo or preproduction samples. If it's reviewed here, it's exactly what you'll buy – not what they'll say you'll buy. And from this month, the reviews section is better than ever. Check it out and see for yourself.

## GREAT FEATURES

Exclusive on-the-spot reports from parts of the games world that other magazines simply cannot reach. Where else would you find a location report from George 'Star Wars' Lucas' Skywalker Ranch programming house, or the castle of Lord 'Ultima' British, or the Hollywood offices of AIM's Interactive Entertainment project? Not to mention up-and-coming reports from Japan, Soviet Union and America – and that's just for starter's!

## GREAT PRIZES!

You could have won a fabulous FM Towns CD-ROM computer, a NEO-GEO console, a Video Cassette Recorder, an all-expenses paid trip to Paris' Science City, a CD Walkman, and £££'s of free software. And if that's not enough for you, check out the incredible prizes we're offering over the next few months in the Win! Win! Win! panel on the right.

allocation – a valuable bonus since space at conferences is strictly limited. Each event is fully covered in the magazine, so you could get your mug in the mag as a bonus!

## InterFACE

Subscribers will receive, completely free of charge, a special quarterly newsletter written exclusively for them by the ACE Team. This will bring you details of some of the topics that we can't, for reasons of space or secrecy (!), mention in the magazine itself. Subscribers will have the chance to contribute to it if they wish. With ACE every month, and InterFACE every three months, you'll really be at the cutting edge of the computer entertainment revolution.

## WIN! WIN! WIN!

Want to go places? Want to grab loads of free software? Here's a couple of great competitions ACE readers can enter over the next few months...

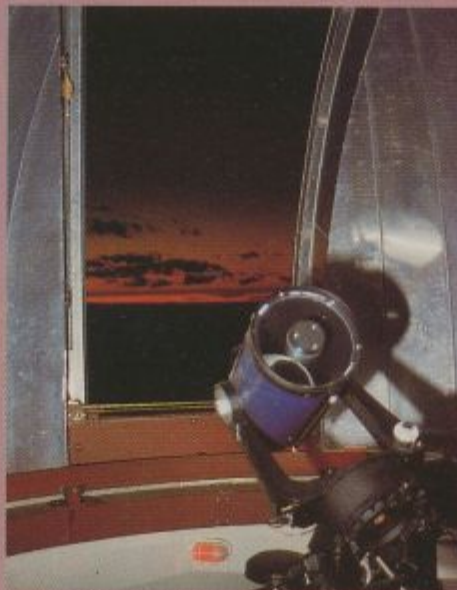

Richard Garriott – Lord British – has built his own private observatory at the top of his house in Texas. You could be gazing at the skies here this Halloween if you're stars are lucky!

NEO GEO – exclusively covered in ACE, and an exclusive chance to own one!

### HOLLYWOOD HIJINX!

Nope, not an Infocom game – but a stunning chance to win a ticket to Universal Studios in Hollywood courtesy of Mirrorsoft. There you'll be taken round some of the sets of recent blockbusting movies, including *Back to the Future II AND III*, plus a secret visit to a new movie location currently being filmed and licensed by Mirrorsoft. Your ticket application is on this month's cover!

### TEXAS CHAINSAW MASSACRE!

Well, not quite. At least we hope not. But a visit to Lord British's renowned Halloween party at his palatial abode in Austin, Texas is bound to be full of surprises. Not only will you get to meet all the Origin gang and see their latest games in development, but you'll also be a VIP guest at the party of a lifetime as LB and his friends stage a massive Halloween spectacular featuring all sorts of special effects and wizardry. Thanks to Origin and Mindscape, you'll be there – and you'll never forget it!

## SPEAK OUT!

As an ACE Reader you also get the opportunity to apply for a place on the ACE Conferences. For just £5 (FREE if you're a subscriber) you get to visit some of Britain's top software houses, a free lunch, bags of freebies (including software, T-shirts, and other goodies), and – most important of all – the chance to meet the people who produce the games you play. You'll be given the opportunity to play some of the new games under development, and to tell the programmers and publishers what you think of them. They'll listen. And you'll have a great time.



At the ACE Domark Conference – future trips include Mirrorsoft (meet the Bitmaps) and Activision. See pages 67/68.

*"An excellent day out and well worth it to other readers."*

From a letter sent to us by a recent attendee at an ACE Conference

# THERE'S ONLY ONE

*Emllyn Hughes*



## INTERNATIONAL



*Audiogenic*

NOW AVAILABLE FOR ATARI ST & AMIGA

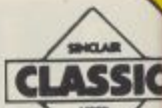

### OVER A YEAR IN THE CHARTS ...OVER 100,000 SOLD!

The 8-bit soccer game of the 80's becomes the 16-bit sensation of the 90's with the release of the long-awaited Atari ST and Amiga versions.

When EMLYN HUGHES INTERNATIONAL SOCCER was released for C64, Spectrum and Amstrad, reviewers were amazed. It rated 90% in ZZAP, 91% in Sinclair User, 88% in Games Machine, 91% in Amstrad Computer User, 94% in Computer & Video Games, 887 in ACE, Game of the Year in CCI - we could go on for ever!

Now, with the release of the Atari and Amiga versions reviewers are reaching for their dictionaries to find new superlatives. ZERO described the game as 'totally excellent', the sound as 'absolutely brilliant' 89%; Your Amiga rated it 'the best soccer simulation to date - 95%'; YC World Cup Winner 97%.

Forget the rest - there's only one EMLYN HUGHES INTERNATIONAL SOCCER!

AUDIOGENIC SOFTWARE LTD

Winchester House, Canning Rd, Wealdstone, Harrow, Middlesex HA3 7SJ. Tel: 081-861-1166

# IN THE PINK

## HARDWARE

Once again this month our computer system has let us down during the output of our Hardware Section. We do apologise for this, and are now busy completely redesigning the section for next month. The redesign will involve creating a new file structure for the pages that will ensure the problem does not reoccur.

### THE ACE CHARTS AND STOCKMARKET .....100

Where else can you find out which games are getting the best reviews in ALL the UK magazines? The ACE Charts are compiled every month by researchers who read each UK magazine they can buy before we go to press. All review marks are entered into a database and statistically processed to produce the Charts, which can also be used as reliable buying guides. And you can win prizes too! If you can predict which games are going to hit the high spots next month, free software could be on its way.

### HOT OFF THE SHELF .....106

You're in the market for a new game. but which one should you buy? The trouble is, most magazines are full of reviews of games that have only just been released and may not even be on the shelves yet. This software buyers section pinpoints games that have been ACE-rated over the last few months and should be readily available from most dealers.

### ACE READERS PAGES .....126

Everything from pen pals to second hand machines in the ACE market place. Please remember, however, that advertisements that encourage software piracy will not be accepted.

### THE ACE PRIZE PUZZLE .....121

Another tough ACE challenge that offers bounty for brain-boxes. This month's teaser is all about gifts in Cornflake packets – solve it and you could get a gift yourself.

### THE ACE PRIZE CROSSWORD .....118

Einstein discovered relativity – a trivial task compared to solving the infamous ACE crossword. Crack it, and we'll reward you handsomely.

### THE ACE DIARY .....117

New releases, anniversaries – facts and trivia for the gamerster who likes to keep up with the times.

### ACE DEALS .....116

If you go down to the shops today, you're in for a big surprise – freebies galore. Better than a teddy bear's picnic.

## ASK JERRY!

We have a full-time Pink Pages reader's liaison officer: Melanie Costin, who will always be on hand to help you out with problems about Reader's Pages and or Pink Pages mailorder difficulties. And if you're a dealer and would like to place an advertisement in the pinks or arrange a voucher offer, contact Jerry Hall on 01-251 6222 Ext. 2452.



FOR

SSIC

N\*1

AR  
TS  
D!

's

1% in  
4%  
ould

ching  
e as  
ted it

CCER!

1-1166.

# ACE CHARTS

PLUS THE ACE STOCKMARKET - THE BEST CHARTS IN THE BUSINESS, AND THE CHANCE TO WIN WIN WIN!

**W**elcome to the ACE charts and Stockmarket - the most accurate, thorough listing of games releases in the country.

How come?

Well, to start with, the ACE Charts are not compiled like other charts. Most organisations who print listings like these either (a) make them up or (b) rely on sales information from retailers. Here at ACE, we thought you deserved something better. What about, we thought, a chart that didn't reflect sales (which are often distorted - or just plain hyped) but a chart that reflected how good the games really were - in the opinion not just of ACE reviewers but other magazines as well.

That's what you've got here. Every game is

rated according to ALL the reviews we've gathered together during the previous month. That means you can look at these charts and tell EXACTLY which games are hot potatoes!

What's more, you can win prizes by trying to predict which games are going to hit the high spots next month. The entry form's on page 128. To make things easy, you can try to pick a winner in any of the charts - and you can go for a jackpot prize by trying to predict the top five in any category as well.

**Top Ten Console Sales compiled by Shekhana Computers, 2 Gladstone House, High Road, Wood Green, London N22. Tel: 081-889 9412, Fax: 081-889 9413 and at 221 Tottenham Court Road, London, W1 Tel: 071-631 4627**

## THE WINNERS: ROUND EIGHT

OK, who gets the goodies this month?

First out of the bag for the Spectrum was **Ben Wicks** of Chorleywood who was one of a small band of punters who correctly predicted that *Pipemania* would be hitting the high spots last month. *3D International Tennis* took the honours in the C64 chart, which should bring a smile to the lips of **Ambereen Akram** of Halesowen who came first out of the hat with correct answer there. Lots of people spotted *F19 Stealth Fighter* on the Atari ST - but it was **Brian Hambley** of Prescott who turned up in the draw. One or two shrewd punters guessed that *Midwinter* would hit the Amiga last month following conversion from the ST and would reach first place - well done to **Richard Mather** of Formby there. *Railroad Tycoon* hit the top spot on the PC last month, which many people predicted but it was **Steven Painter** of Wrexham who came first out of the hat. Well done, meboy.

Now for the bad news. Not one of you lily livered scoundrels managed to spot *Castle Master* for the CPC. Surely that one wasn't TOO difficult! And even more astonishing, despite the tremendous reception given to *Ultima VI*, no-one guessed that Origin would be number one in the Stockmarket (Company Counter). Even more extraordinary, many of you who submitted the Stockmarket as your jackpot choice didn't mention Origin at all. Very strange.

Meanwhile, our further apologies to those of you who are still awaiting prizes. All prizewinners (except this month's) should now have received a letter from us. Prizes are now on their way. Yahoo!

## THE STOCKMARKET

The ACE Stockmarket gets its name from the fact that each month we list the top software companies together with a 'share price' for each one. The Stockmarket tells you which software houses are currently producing the most successful titles.

There are four columns for each company. The first shows the company's Rating - a figure calculated according to the reviews its games have received during the current month. A company whose games are all rated highly will have a high Rating.

The next column in the company counter is the +/- Difference. This simply tells you how well a company is doing compared to last month.

The third column is the Price. This is a rating of the company's current performance compared to its performance in all previous months that it has appeared in the Stockmarket. If you wanted to buy shares in a company, check this column! Note that companies who get no reviews at all have their price decreased each month until they get reviewed again.

Finally, there's the company's Index. This shows how well a company's games have done this month compared to the average score gained by all the other games reviewed. It's this rating that determines the position of a company in the charts. This month reviews of Origin games have been a staggering 22% higher than those for other titles - could that be the *Ultima VI* effect, we wonder?

The average score for ALL games reviewed each month is called the SOFTWARE INDEX and it's printed at the top of the Stockmarket. This helps you tell whether or not the current month was a bumper month for gamers. This month it's down down down...

## THE 16 BIT CHART

Title	Publisher	Format	Rating
Midwinter	Rainbird	Amiga, PC	95.5
Railroad Tycoon	Microprose	PC	93
Ultima VI	Origin	PC	92.75
F19 Stealth Fighter	Microprose	PC, ST	91
Hammerfist	Activision	Amiga	89.63
Turrican	Rainbow Arts	Amiga	89
Budokan	Electronic Arts	Amiga, PC	88.63
Combo Racer	Gremlin	Amiga, ST	88.25
Player Manager	Anco	Amiga	88.17
Flimbo's Quest	System 3	Amiga	88

Bubbling under: *Their Finest Hour* (US Gold) on Amiga and PC, *Might and Magic II* (US Gold) on the Amiga and *International 3D Tennis* (Palace), also on the Amiga.

## THE 8-BIT CHART

Title	Publisher	Format	Rating
International 3D Tennis	Palace	C64, Sp	93.38
Flimbo's Quest	System 3	C64	89.25
Bloodwych	Image Works	Sp	87
Klax	Domark	Sp	86.25
Pipemania	Empire	CPC, Sp	85.84
Lords of Chaos	Blade	Sp	84.25
Fiendish Freddy	Mindscape	Sp	79.17
World Ch'ship Boxing Mgr	Goliath Games	CPC, Sp	78
Yogi's Great Escape	Hi Tec	CPC, Sp	75.75
Overlander	Encore	CPC, Sp	75.34

Bubbling under: *Ninja Spirit* (Activision) on C64, CPC, and Spectrum, *Hopping Mad* (Encore) on C64 and Spectrum, and *Impossamole* (Gremlin) on C64, and Amstrad CPC.

## THE MACHINE CHARTS

### AMIGA RATINGS

Midwinter	Rainbird	91
F29 Retaliator	Ocean	90.84
Hammerfist	Activision	89.63
Turrican	Rainbow Arts	89
Rotox	US Gold	88.3

It's all very tight at the top in the Amiga chart this month, with *Player Manager*, *Flimbo's Quest* (System 3) and *Their Finest Hour* (US Gold) also scoring over 87% on average. *Midwinter* has topped both the ST and PC charts before and it's obviously converted well.

### AMSTRAD CPC RATINGS

Castle Master	Domark	84.34
Pipemania	Empire	84
World Cup Compilation	Empire	80
World Ch'ship Boxing Manager	Goliath Games	76
World Cup Italia 90	Virgin	67.78

No respite from football, as both Virgin and Empire's offerings make it into the top five. But there's not much strength in depth in the CPC market at the moment, with *Castle Master* and *Pipemania* so clearly ahead of the pack.

### IBM PC AND COMPATIBLE RATINGS

Railroad Tycoon	Microprose	93
Ultima VI	Origin	92.75
Pipemania	Empire	88.75
Their Finest Hour	US Gold	88
LHX Attack Chopper	Electronic Arts	85.97

*Ultima VI's* ratings have improved over four points over last month, but it's still been knocked off the top spot, as *Railroad Tycoon* steams in. Strategy/simulation titles always fare better on the PC than out and out arcade action - no exception to that rule this month.

### SPECTRUM RATINGS

Pipemania	Empire	87.67
Bloodwych	Image Works	87
Klax	Domark	86.25
Lords of Chaos	Blade	84.25
Fiendish Freddy	Mindscape	79.17

*Pipemania* is featuring strongly in all our machine charts - on the Spectrum it's top of the pile. Domark's *Klax*, while a very different game, is of the same genre, while *Bloodwych*, a highly rated 16-bit success, offers Spectrum owners something different from the usual budget/arcade-based fare.

### ATARI ST RATINGS

F19 Stealth Fighter	Microprose	93
Resolution 101	Millenium	89.29
Castle Master	Domark	86.17
Escape/Robot Monsters	Domark	84.09
Projectyle	Electronic Arts	83.75

A clear winner with the reviewers this month, despite a generally high-scoring top five, with *F19* the only title to score over 90% consistently. *Castle Master* and *Robot Monsters* are on their way down, *Resolution 101* and *Projectyle* on their way up.

### COMMODORE 64 RATINGS

International 3D Tennis	Palace	95.25
Ninja Spirit	Activision	90
Flimbo's Quest	System 3	89.25
Parallax	Hit Squad	88
Hot Rod	Activision	80.25

There's new life in the Commodore 64 games market at the moment - for the second month in a row, a 64 title gets the highest rating of the lot. Palace's 3D wire frame graphics presentation, unusual for a sports simulation, comes off to good effect on this format.

## TOP CONSOLE GAME SALES IN MARCH 1990

These are the console games that are selling the most copies at Shekhana's London outlets...

It's all change this month on the Megadrive with a host of new titles reflecting the sudden increased interest in the system prior to its launch by Virgin.

On the other hand, the Lynx sticks with the same old top five - software isn't exactly flooding out for this system, perhaps because the market is distracted by the promised launch of the PC Engine handheld.

### SEGA MEGADRIVE TOP 10

- 1 THUNDERFORCE III
- 2 D.J. BOY
- 3 GOLDEN AXE
- 4 GHOULS AND GHOSTS
- 5 WHIP LASH
- 6 SUPER SHINOBI
- 7 FORGOTTEN WORLDS
- 8 FINAL BLOW
- 9 CURSE
- 10 ASSAULT SUIT LEYNOS

### PC ENGINE TOP 10

- 1 SPLATTER HOUSE
- 2 POWER DRIFT

- 3 PARANOIA
- 4 BARUMBA
- 5 CHASE HQ
- 6 NEW ZEALAND STORY
- 7 TENNIS
- 8 SHINOBI
- 9 CYBER CORE
- 10 SUPER VOLLEYBALL

### GAME BOY TOP 10

- 1 BATMAN
- 2 MAKAIMURA GAIDEN
- 3 TETRIS
- 4 TENNIS
- 5 POPEYE

- 6 SUPER MARIO LAND
- 7 SOCCER BOY
- 8 SNOOPY
- 9 WIZARD
- 10 QUIX

### LYNX TOP 5

- 1 CALIFORNIA GAMES
- 2 BLUE LIGHTNING
- 3 CHIPS CHALLENGE
- 4 GATES OF ZENDOCON
- 5 ELECTROCOP

## THE ACE STOCKMARKET - THE TOP 25 SOFTCOS

Last month we asked if reviewers were becoming more generous with their marking, as the Software Index rose to nearly 74. The answer appears to be a definite 'no', since the index this month has plummeted down to 72.19.

We think there are two possible reasons for this: firstly that many companies consciously hold back their 'top' games for an autumn release and we're now in the middle of the low summer season, and secondly, you can't have failed to notice all those World Cup football round-ups, and with a few honourable exceptions (such as Anco's *Player Manager* or US Gold's *Italy 1990*), football games haven't

been getting very high ratings. If these explanations are correct, you should see a slight rise next month (no more soccer games) and a bigger one in the October issue. Watch this space ...

It's clear that the strategy enthusiasts are getting the best games at the moment, with Origin, Microprose and SSI filling the top three places in the company counter.

Companies rated 100 and marked \* are 'new entries'. They haven't featured in the Counter

before and a company's launch share price is always 100. Companies with an existing share price but no reviews lose 10 points for each month that no reviews appear.

**THIS MONTH'S SOFTWARE INDEX RATING:**  
**72.19**  
**PLUMMETING DOWN!**

Company	Ratings +/-	Price	Index											
Origin	94.25	23.37	132.97	22.06	Zeppelin	82.5	13.17	119	10.31	Domark	77.74	-5.87	92.98	5.55
Microprose	89	-1	98.89	16.81	Palace	81.56	-1.51	98.18	9.37	Firebird	77.25	n/a	139.44	5.06
SSI/US Gold	87.83	5.5	106.68	15.64	Britannica	81.5	n/a	100*	9.31	Image Works	77	-10.75	87.75	4.81
Blade	86	3.5	104.24	13.81	Anco	79.84	-11.75	87.17	7.65	Electrocoin	76.95	4.95	106.88	4.76
System 3	84.5	-8.25	91.11	12.31	Gonzo Games	79.69	0.94	101.19	7.5	US Gold	76.35	-0.58	99.25	4.16
Empire	83.4	14.85	121.66	11.21	Cinemaware	79.5	-7.43	91.45	7.31	Millennium	76.27	-6.6	92.04	4.08
Rainbird	82.88	0.68	100.83	10.69	Loriciel	79.31	3.31	104.36	7.12	Electronic Arts	76.23	3.43	104.71	4.04
					Sierra	79.08	6.33	108.7	6.89	Psygnosis	76.19	1.79	102.41	4
					Rainbow Arts	78	-8.5	90.17	5.81	Gremlin	75.96	-3.42	95.69	3.77

# Special Reserve

Best PRICES, Best GAMES, Best SERVICE

## Just £5.00 Annual Membership Fee

- Bi-monthly *Buyer's Guides*, each with reviews of 40 games and more.
- *Release Schedules*, issued bi-monthly, with advance release information.
- *7-day hotline*, to 8pm weekdays, 10 to 5.30 Saturdays, 11 to 5 Sundays.
- *Fast despatch* of stock items. Most lines in stock.
- *Catalogue, Membership Card & Folder* for the Buyer's Guides.

### ATARI LYNX



(In stock at time of publication)

Atari Lynx colour handheld games system with mains powerpack and California Games cartridge.

**£154.99**

Blue Lightning 21.99 Chips Challenge 21.99  
Electro Cop 21.99 Gates of Zendecon 21.99

### Joysticks



Euromax Racemaker Joystick (Yoke) .....25.99  
Euromax Ultimate Rapid Fire Joystick (Wide Base) 16.99  
Dynamics Competition Pro Extra (Clear Base) ...13.99  
Naksha Mouse, Bracket & Mat (Amiga, ST, IBM) 34.99

### AMIGA and ATARI ST Software

16 BIT	AMIGA	ST	16 BIT	AMIGA	ST	16 BIT	AMIGA	ST
888 ATTACK SUB	16.99		GHOULS 'N' GHOSTS	16.49	13.49	POPULOUS	16.49	16.49
ADIDAS CHAMP FOOTBALL	15.99	15.99	GRAVITY	16.49	16.49	POPULOUS PROMISED LANDS	7.99	
AMOS (GAMES CREATOR)	27.49		GRIDIRON (U.S. FOOTBALL)	15.49	15.49	POWERDROME	16.49	
AMOS SPRITES 1000	9.99		GUNSHIP	15.99		PRO TENNIS TOUR	16.49	
AMOS VIDI DIGITISER	51.49		HAMMERFIST	15.99	15.99	PROTEXT W/PROCESSOR	64.99	
ANARCHY	15.99	15.99	HARLEY DAVIDSON	15.49		PUBLISHERS CHOICE DTP		
B.S.S. JANE SEYMOUR	18.99	16.99	HERO'S QUEST	21.99	21.99	(KIND WORDS 2, PAGESETTER 1,2,		
BACK TO THE FUTURE 2	15.99	15.99	HITCHHIKERS GUIDE	39.99	24.99	ARTISTS CHOICE, CAL FONTS,		
BACKGAMMON PRO	14.99	14.99	HOME OFFICE KIT (KIND WORDS 2.0,			RAINBOW SCRIPT) (1 MEG)	59.99	
BALANCE OF POWER 1990	15.49	15.49	MAXI PLAN, INFO FILE, PAGESETTER			RESOLUTION 101	15.99	
BATMAN THE MOVIE	15.99	15.99	ARTISTS CHOICE, FONTS)	86.49		RISK	12.49	
BATTLE OF BRITAIN	19.99	19.99	HONDA RVF 750	15.49	15.49	ROBOCOP	15.49	
BATTLECHESS	16.49	16.49	HOUND OF SHADOW	16.99	16.99	ROTOR	16.99	
BATTLEHAWKS 1942	16.49	16.49	IMPERIUM	16.99	16.99	ROURKE'S DRIFT	15.99	
BEYOND ZORK (INFOCOM)	24.99		INDIANA JONES ACTION		13.49	SCRABBLE DE LUXE	12.99	
BLADE WARRIOR	15.99	15.99	INDIANA JONES ADVENTURE	16.99	16.99	SECRET AGENT SLY SPY	15.99	
BLOODWICH DATA DISK	9.99	9.99	INFESTATION	15.49	15.49	SHADOW OF THE BEAST		
BOMBER	18.49	18.49	INFIDEL (INFOCOM)	16.49	17.99	SHADOW WARRIORS	15.99	
BOMBER MISSION DISK	13.49	13.49	INTERNATIONAL 3D TENNIS	16.49	16.49	SHADOWWATERS	15.99	
BRIDGE PLAYER 2150	19.99	19.99	IRON LORD	16.49	16.49	SHADOWWATERS	15.99	
BUDOKAN	16.49		IT CAME FROM THE			SHADOWWATERS	15.99	
CABAL	15.49	12.99	DESERT DATA DISK (1 MEG)	10.49		SHADOWWATERS	15.99	
CARTOON CAPERS	12.49	12.49	ITALY 1990 (US GOLD)	16.99	16.99	SHERMAN M4	16.99	
CASTLE MASTER	15.99	15.99	JACK NICKLAUS GOLF	16.49	16.49	SHOOT 'EM-UP CONSTR KIT	9.99	
CHAOS STRIKES BACK EDITOR	10.49		JACK NICKLAUS GOLF DATA1	8.99		SIM CITY TERRAIN EDITOR	27.49	
CHAMP H.O.	15.99	12.99	JUMPING JACKSON	12.49	12.49	SPACE ACE	27.49	
CHESS CHAMPION 2175	19.99	19.99	KEEP THE THIEF	17.49		SPACE QUEST 1 (SIERRA)	16.49	
CODENAME ICEMAN	24.49	24.49	KICK OFF	12.49	12.49	SPACE QUEST 2 (SIERRA)	16.49	
COLONEL'S BEQUEST	24.49	24.49	KICK OFF 2	12.49	12.49	SPACE QUEST 3 (SIERRA)	17.49	
COLORADO	15.99	15.99	KICK OFF EXPANSION DISK	7.49	7.49	SPACE ROGUE	17.49	
COLOSSUS CHESS X	15.49	15.49	KIND WORDS 2.0 (W/P)	29.99		SPELLBREAKER (INFOCOM)	24.99	
CONQUEROR	15.99	15.99	KINGS QUEST 1, 2 & 3	21.49	22.49	STARBLADE	16.49	
CONQUEST OF CAMELOT	23.99		KINGS QUEST 4 (SIERRA)	21.49	21.49	STARBUCKS (INFOCOM)	24.99	
CRACK DOWN	16.99	12.99	KLAX	12.99	12.99	STARFLIGHT (KIND WORDS 2.0,	16.99	
CYBERBALL	12.99	12.99	KNIGHTFORCE		13.99	STARTER KIT (KIND WORDS 2.0,	16.99	
DAMOCLES	15.49	15.49	KNIGHTS OF CRYSTALLION	19.99		FUSION PAINT, SUPER SKI, CRAZY	16.99	
DEJA VU 2	15.49	15.49	KRISTAL		16.49	CARS, MINIATURE GOLF)	43.49	
DELUXE PAINT III	51.49		LASER SQUAD		12.99	STEVE DAVIS SNOOKER	12.49	
DEMONS TOMB	15.99	15.99	LEADERBOARD BIRDIE	16.49	13.49	STRYX	12.99	
DOUBLE DRAGON 2	13.49	13.49	LEATHER GODDESSES		17.49	STUNT CAR RACER	15.99	
DRAGON NINJA	15.99	12.99	LEISURE SUIT LARRY 1	18.99	18.99	TANK ATTACK	14.49	
DRAGON'S LAIR	28.49	28.49	LEISURE SUIT LARRY 2	21.49		TEAM YANKEE	17.49	
DRAGONS BREATH	18.99	18.99	LEISURE SUIT LARRY 3	24.49	24.49	THE LOST PATROL	15.99	
DRIVING FORCE	16.49	16.49	LIVERPOOL	11.99	11.99	THEME PARK MYSTERY	15.99	
DUNGEON MASTER EDITOR	7.49	7.49	LURKING HORROR	24.99		THIRD COURIER	15.99	
DYNASTY WARS	16.99	13.99	MANCHESTER UNITED	15.99	12.99	THUNDERSTRIKE	16.49	
E-MOTION	16.99	13.49	MANIAC MANSION	16.99	16.99	TIE BREAK	15.99	
ELVIRA	19.49	19.49	MAVIS BEACON TYPING	17.99	17.99	TIMES OF LORE		
ESCAPE SINGE'S CASTLE	28.49		MIDWINTER	18.99	18.99	TIMESWORKS DTP		
ESCAPE FROM THE PLANET			MIGHT AND MAGIC 2	19.99		TOWER OF BABEL	16.49	
OF THE ROBOT MONSTERS	12.99	12.99	MINI OFFICE PRO COMMS		17.49	TREASURE TRAP	15.99	
EUROPEAN SUPER LEAGUE	15.49	15.49	MINI OFFICE PRO GRAPHICS		17.49	TURRICAN	12.49	
F16 COMBAT PILOT	15.99	15.99	MINI OFF PRO SPREADSHEET		17.49	ULTIMA 4	17.99	
F19 STEALTH FIGHTER	18.99	18.99	MUSIC X	99.99		ULTIMA 5	17.99	
F29 RETALIATOR	15.99	15.99	NEW ZEALAND STORY	12.99	12.99	UNTOUCHABLES	15.99	
FERRARI FORMULA 1	16.49	16.49	NINJA SPIRIT	15.99	15.99	VENUS - THE FLY TRAP	13.49	
FINAL BATTLE	15.99	15.99	NINJA WARRIORS	16.49	12.99	VETTE (CORVETTE)	18.49	
FIRE AND BRIMSTONE	16.49	16.49	OMNI-PLAY HORSE RACING	15.49		VYIKING CHILD	15.99	
FIRST WORD PLUS	58.99		OPERATION THUNDERBOLT	15.99	12.99	WARHEAD	15.99	
FLAIR PAINT 2	22.49		PAPERBOY	12.99	12.99	WAYNE GRETZKY HOCKEY	15.99	
FLOOD	16.99	16.99	PERSONAL NIGHTMARE	17.49	17.49	WINGS (CINEMAWARE)	18.99	
FOOTBALL DIRECTOR 2	12.99	12.99	PHANTASIE 3 (SS)	49.99		WORLD BOXING MANAGER	12.99	
FULL METAL PLANET	15.49	15.49	PHOTON PAINT 2.0 (1 MEG)	49.99		WORLD CUP SOCCER, ITALIA 90	12.49	
FUN SCHOOL 3 (2-5 YRS)	15.49	15.49	PIPEMANIA	15.99	15.99	X-OUT	12.49	
FUN SCHOOL 3 (5-7 YRS)	15.49	15.49	PIRATES	12.49	12.49	XENOMORPH	15.49	
FUN SCHOOL 3 (7+ YRS)	15.49	15.49	PLAYER MANAGER	15.99	15.99	ZOMBI	16.49	
FUTURE WARS	16.49	16.49	POLICE QUEST 1 (SIERRA)	21.99	16.49	ZORK 1 (INFOCOM)	35.99	
GAUNTLET 2	7.99	7.99	POLICE QUEST 2 (SIERRA)	21.99	16.49	ZORK TRILOGY (INFOCOM)	35.99	

UNAVAILABILITY, SOME OF THE ABOVE GAMES MAY NOT YET BE RELEASED. ALL GAMES ARE DESPATCHED AS SOON AS POSSIBLE. PLEASE NOTE THAT THERE IS A SURCHARGE OF 50P PER GAME FOR ORDERS PLACED BY TELEPHONE. Special Reserve and Official Secrets are trading names of Inter-Mediate Ltd. Reg. Office: 2 South Block, The Mall, Sawbridgeworth, Herts CM21 9PG. Registered in England Number 2054733. VAT reg. no. 424 8532 51

### AMIGA Mega-Savers

ALTERED BEAST	7.49	KRISTAL	8.99
ARCHIPALAGOS	6.99	KULT	7.49
ARKANOID	10.49	LANCELOT (LEVEL 9)	6.99
AUSTERLITZ (BATTLE OF)	11.99	LASER SQUAD	7.99
BAAL	6.99	LEATHER GODDESSES	9.99
BALLISTIX	6.49	LEATHERNECKS	10.49
BALLYHOO (INFOCOM)	8.99	LOMBARD RAC RALLY	10.49
BLACK CAULDRON	7.99	LORDS OF THE RISING SUN	4.99
BLACK LAMP	6.99	MENACE	8.49
BLOOD MONEY	7.49	MICROPROSE SOCCER	8.49
BLOODWICH	7.49	MILLENNIUM 2.2	5.99
BUGGY BOY	9.49	NEVER MIND	6.49
CARRIER COMMAND	7.99	NEW ZEALAND STORY	6.49
CHAMP (USA) GFL FOOTBALL	4.99	NIGEL MANSELL'S GRAND PRIX	5.99
CHESSMASTER 2000	8.49	NORTH AND SOUTH	10.49
CHRONOQUEST 2	9.49	PACLAND	5.99
CLOUD KINGDOMS	7.99	PACMANIA	6.49
CONFLICT EUROPE	5.99	PASSING SHOT (TENNIS)	8.49
CONTINENTAL CIRCUS	11.49	PAWNI (M/SCROLLS)	9.99
CORRUPTION (M/SCROLLS)	9.99	PHOTON PAINT	6.49
CUTTHROATS (INFOCOM)	15.49	POWER DRIFT	4.99
DRAKKHEN	13.99	ROCKET RANGER	8.99
DUNGEON MASTER (1 MEG)	9.99	SHADOW OF THE BEAST + SHIRT	10.99
DYNAMITE DUX	7.49	SHOGUN (INFOCOM)	9.99
EDDIE EDWARDS SUPER SKI	4.99	SIM CITY	13.99
ELIMINATOR (1.2 AMIGAS ONLY)	4.49	SPEEDBALL	6.49
ELITE	9.99	STARGLIDER 2	11.49
EYE OF HORUS	11.99	SUPER WONDERBOY	7.99
F16 FALCON	11.99	SWORD OF SODAN	7.99
F16 FALCON MISSION DISK	7.99	TEENAGE QUEEN (STRIP POKER)	8.49
FAST BREAK (VOLLEYBALL)	6.49	THE PRESIDENT IS MISSING	5.99
FISH (M/SCROLLS)	9.99	THREE STOOGES (CINEMAWARE)	6.99
FOOTBALL MANAGER 2 + EXP	10.99	THUNDERBIRDS	5.99
FOOTBALL MANAGER WORLD CUP	10.99	TIME & MAGIC (LEVEL 9)	7.99
FUN SCHOOL 2 2-6, 6-8 OR 8+	7.99	TRIAD VOL2 (MENACE, BAAL, TETRIS)	7.99
GUILD OF THIEVES (M/SCROLLS)	9.99	TRIVIAL PURSUIT	8.49
HARD DRIVIN'	9.99	TURBO CUP	6.49
HIT DISKS VOLUME 2	8.49	TV SPORTS BASKETBALL	11.99
HOSTAGES	7.49	TV SPORTS FOOTBALL (U.S.A.)	11.99
HYBRIS	5.99	UMS - UNIVERSAL MILITARY SIM	7.49
INDIANA JONES ACTION	11.49	VIRUS	8.49
INTERNATIONAL KARATE +	7.49	VOYAGER	10.49
IT CAME FROM THE DESERT (1 MEG)	10.99	WATERLOO	9.99
JINXTER (M/SCROLLS)	9.99	WHO FRAMED ROGER RABBIT	9.99
KID GLOVES	7.49	XENON 2, MEGABLAST	6.99
KING OF CHICAGO	11.99		

Amiga 512k Ram upgrade to 1 meg **99.99**  
(genuine item with clock)

### Atari ST Mega-Savers

AFTERBURNER	8.49	LURKING HORROR (INFOCOM)	
ALTERED BEAST	6.99	MENACE	8.49
ARCHIPALAGOS	6.49	MICKEY MOUSE	15.99
AUSTERLITZ (BATTLE OF)	11.49	MILLENNIUM 2.2	11.49
BAAL	5.99	NEVER MIND	6.49
BALLISTIX	6.49	NIGEL MANSELL'S GRAND PRIX	5.99
BALLYHOO (INFOCOM)	7.99	NORTH AND SOUTH	10.49
BATMAN CAPED CRUSADER	6.99	OIDS	8.49
BEYOND ZORK (INFOCOM)	8.49	P47 THUNDERBOLT	7.49
BLOOD MONEY	7.49	PACLAND	5.99
BLOODWICH	7.49	PACMANIA	6.49
BUGGY BOY	8.99	PANDORA	9.99
CARRIER COMMAND	7.99	PASSING SHOT (TENNIS)	8.49
CHAOS STRIKES BACK	9.99	PAWNI (M/SCROLLS)	9.99
CHAMP (USA) GFL FOOTBALL	4.99	PURPLE SATURN DAY	7.49
CHESSMASTER 2000	7.49	R-TYPE	7.49
CHRONOQUEST 2	9.49	ROCKET RANGER	8.99
CLOUD KINGDOMS	7.99	SDI (ACTIVISION)	9.99
CONFLICT EUROPE	5.99	SEASTALKER (INFOCOM)	10.99
CORRUPTION (M/SCROLLS)	9.99	SHADOWGATE	15.99
DEJA VU	4.49	SILICON DREAMS (LEVEL 9)	13.99
DRAKKHEN	13.99	SIM CITY	9.99
DUNGEON MASTER	9.99	SKYCHASE	9.99
EDDIE EDWARDS SUPER SKI	4.99	SORCERER (INFOCOM)	4.49
ELIMINATOR	4.49	SPEEDBALL	9.99
ELITE	9.99	SPELLBREAKER (INFOCOM)	24.99
EXOLON	3.99	ST ADVENTURE CREATOR	10.99
EYE OF HORUS	5.99	STAR RAY	7.99
F16 FALCON	10.99	STARGLIDER (INFOCOM)	10.99
F16 FALCON MISSION DISK	7.99	STARGLIDER 2	11.49
FISH (M/SCROLLS)	9.99	STATIONFALL (INFOCOM)	7.99
FOOTBALL MANAGER 2 + EXP	10.99	SUPER HANG ON	7.99
FOOTBALL MANAGER WORLD CUP	10.99	TEENAGE QUEEN (STRIP POKER)	8.49
FUN SCHOOL 2 2-6, 6-8 OR 8+	7.99	TETRIS	7.49
GUILD OF THIEVES (M/SCROLLS)	9.99	THUNDERBIRDS	5.99
HARD DRIVIN'	9.99	TIME & MAGIC (LEVEL 9)	7.99
HIT DISKS VOLUME 2	8.49	TIME BANDIT	7.49
HOSTAGES	7.49	TRINITY (INFOCOM)	8.99
HYBRIS	5.99	TRIVIAL PURSUIT	8.49
INDIANA JONES ACTION			

## Can you afford not to join?

- Games sent *individually wrapped by first class post.*
- We send *written confirmation of order* (receipt).
- In the event of delay, *refunds on request.*
- No commitment, no obligation to buy**
- The best games at the best prices**



### IBM PC & Compatible Software

AMIGA	ST	DISK SIZE	5.25	3.5	DISK SIZE	5.25	3.5
16.49	16.49	ATTACK SUB			FUN SCHOOL 2 (6-8) CGA/EGA	12.99	
7.99	7.99	ATANK KILLER	19.99	19.99	FUN SCHOOL 2 (8+) CGA/EGA	12.99	
16.49		BURNER M/CGA/EGA/VGA	24.49		GALDREGON'S DOMAIN EGA	15.99	15.99
16.49	16.49	CGAMMON PROFESSIONAL	18.99		GALDREGON'S DOMAIN VGA	17.99	17.99
84.99	47.99	CGAMMON	15.99		GO PLAYER PROFESSIONAL (ORIENTAL CHESS)	19.99	19.99
		CGAMMON M/CGA/EGA/VGA	21.49	21.49	GUNBOAT	18.99	18.99
		CGA/EGA	7.99	7.99	GUNS AND BUTTER	19.99	19.99
		CGA/EGA	17.49	17.49	GUNSHIP M/CGA/EGA	23.47	23.47
		CGA/EGA	13.49	13.49	HARD DRIVIN' CGA/EGA/VGA	16.49	16.49
		CGA/EGA	23.49	23.49	HARPOON CGA/EGA	24.49	24.49
		CGA/EGA	17.49	17.49	HEAD COACH (U.S. FOOTBALL)	18.49	18.49
		CGA/EGA	15.99	15.99	HERO'S QUEST M/CGA/EGA/VGA	27.99	27.99
		CGA/EGA	16.49	16.49	HILLSFAR CGA/EGA (SSI)	18.49	
		CGA/EGA	16.49	16.49	HITCHHIKERS GUIDE	15.99	
		CGA/EGA	21.49		HOORAY FOR HENRIETTA	15.99	15.99
		CGA/EGA	13.49		HOYLES BOOK OF GAMES M/CGA/EGA/VGA	19.48	
		CGA/EGA	19.99	19.99	INDIANA JONES ACTION	16.49	16.49
		CGA/EGA	21.99	21.99	INDIANA JONES ADVENTURE	20.49	20.49
		CGA/EGA	18.99	18.99	INDIANAPOLIS 500 CGA/EGA/VGA	16.99	16.99
		CGA/EGA	17.49	17.49	JACK NICKLAUS GOLF CGA/EGA	16.99	16.99
		CGA/EGA	19.99	19.99	JACK NICKLAUS GOLF DATA1	9.49	9.49
		CGA/EGA	17.99	17.99	KICK OFF	15.49	
		CGA/EGA	15.99	15.99	KINGS QUEST 1, 2 & 3 M/CGA/EGA/VGA	23.49	23.49
		CGA/EGA	15.99	15.99	KINGS QUEST 4 M/CGA/EGA/VGA	22.49	22.49
		CGA/EGA	15.99	15.99	KLAX	15.99	15.99
		CGA/EGA	27.99	27.99	KNIGHTS OF LEGEND CGA/EGA	18.49	18.49
		CGA/EGA	27.99	27.99	LEISURE SUIT LARRY 1 M/CGA/EGA/VGA	16.99	16.99
		CGA/EGA	27.99	27.99	LEISURE SUIT LARRY 2 M/CGA/EGA/VGA	22.49	22.49
		CGA/EGA	16.49	16.49	LEISURE SUIT LARRY 3 M/CGA/EGA/VGA	27.99	27.99
		CGA/EGA	15.99	15.99	LHX ATTACK CHOPPER	25.99	25.99
		CGA/EGA	16.49	16.49	LIFE AND DEATH CGA/EGA	15.99	15.99
		CGA/EGA	27.99	27.99	LIVERPOOL	15.49	
		CGA/EGA	27.99	27.99	LOOM M/CGA/EGA/VGA	23.99	23.99
		CGA/EGA	14.99	14.99	M1 TANK EGA (MIRRORSOFT)	21.49	21.49
		CGA/EGA	21.49	21.49	M1 TANK PLATOON CGA/EGA/VGA	25.49	25.49
		CGA/EGA	16.49	16.49	MANHUNTER SAN FRANCISCO M/CGA/EGA/VGA	22.49	22.49
		CGA/EGA	24.99	24.99	MANIC MANSION	17.49	
		CGA/EGA	16.49	16.49	MAVIS BEACON TEACHES TYPING CGA/EGA	18.49	18.49
		CGA/EGA	16.49	16.49	MECHWARRIOR CGA/EGA/VGA	19.49	19.49
		CGA/EGA	28.99	28.99	MIDWINTER	22.49	22.49
		CGA/EGA	24.99	24.99	OMNI-PLAY BASKETBALL	15.99	15.99
		CGA/EGA	22.49	22.49	OMNI-PLAY HORSE RACING	15.99	15.99
		CGA/EGA	16.99	16.99	PAPERBOY CGA/EGA	16.99	16.99
		CGA/EGA	20.99	20.99	PERSONAL NIGHTMARE	15.99	
		CGA/EGA	16.99	16.99	POLICE QUEST 1 M/CGA/EGA/VGA	16.99	16.99
		CGA/EGA	19.99	19.99	POLICE QUEST 2 M/CGA/EGA/VGA	19.99	19.99
		CGA/EGA	18.49	18.49	POOL OF RADIANCE (SSI) CGA/EGA	18.49	18.49
		CGA/EGA	17.49	17.49	POPULOUS CGA/EGA/VGA	17.49	17.49
		CGA/EGA	7.99	7.99	POPULOUS PROMISED LANDS	7.99	7.99
		CGA/EGA	16.99	16.99	POWERPOW CGA/EGA	16.99	16.99
		CGA/EGA	22.49	22.49	RAILROAD TYCOON	22.49	22.49
		CGA/EGA	19.99	19.99	RAPCON	19.99	19.99
		CGA/EGA	19.99	19.99	RED LIGHTNING (SSI) CGA/EGA	19.99	19.99
		CGA/EGA	22.49	22.49	RED STORM RISING CGA/EGA/VGA	22.49	22.49
		CGA/EGA	16.49	16.49	RICK DANGEROUS CGA/EGA	16.49	16.49
		CGA/EGA	16.49	16.49	RISK CGA/EGA	16.49	16.49
		CGA/EGA	13.99	13.99	ROBOCOP CGA/EGA	13.99	13.99
		CGA/EGA	16.49	16.49	SARGON 3 CHESS	16.49	16.49
		CGA/EGA	12.99	12.99	SCAPEGHOST (LEVEL 9) M/CGA/EGA	12.99	12.99
		CGA/EGA	16.49	16.49	SCRABBLE DE LUXE CGA	16.49	
		CGA/EGA	17.49	17.49	SHERMAN M4 CGA/EGA	17.49	17.49
		CGA/EGA	25.49	25.49	SILENT SERVICE 2 CGA/EGA/VGA	25.49	25.49
		CGA/EGA	9.99	9.99	SIM CITY TERRAIN EDITOR CGA/EGA	9.99	9.99
		CGA/EGA	27.99	27.99	SORCERIAN M/CGA/EGA/VGA	27.99	27.99
		CGA/EGA	16.99	16.99	SPACE QUEST 1 M/CGA/EGA/VGA	16.99	16.99
		CGA/EGA	19.49	19.49	SPACE QUEST 2 M/CGA/EGA/VGA	19.49	19.49
		CGA/EGA	22.49	22.49	SPACE QUEST 3 M/CGA/EGA/VGA	22.49	22.49
		CGA/EGA	17.99	17.99	SPACE ROGUE CGA/EGA	17.99	17.99
		CGA/EGA	17.49	17.49	STAR TREK 5 (MINDSCAPE) EGA/VGA	17.49	17.49
		CGA/EGA	16.99	16.99	STARBLADE	16.99	
		CGA/EGA	16.99	16.99	STARFLIGHT 2 CGA/EGA/VGA	16.99	16.99
		CGA/EGA	16.49	16.49	STUNT CAR RACER CGA/EGA/VGA	16.49	16.49
		CGA/EGA	16.49	16.49	SUSPECT (INFOCOM)	16.49	
		CGA/EGA	19.49	19.49	SWARD OF THE SAMURAI CGA/EGA/VGA	19.49	19.49
		CGA/EGA	18.49	18.49	TANGLED TALES CGA/EGA	18.49	18.49
		CGA/EGA	16.49	16.49	THEME PARK MYSTERY	16.49	16.49
		CGA/EGA	16.99	16.99	THUNDERSTRIKE	16.99	16.99
		CGA/EGA	16.49	16.49	TIMES OF LORE	16.49	
		CGA/EGA	19.99	19.99	TRACON	19.99	19.99
		CGA/EGA	17.49	17.49	TRINITY (INFOCOM)	17.49	
		CGA/EGA	15.99	15.99	TURF (SPORTS STRATEGY)	15.99	15.99
		CGA/EGA	19.99	19.99	TV SPORTS FOOTBALL (U.S. FOOTBALL) EGA/VGA	19.99	19.99
		CGA/EGA	17.99	17.99	ULTIMA 4 CGA/EGA	17.99	17.99
		CGA/EGA	21.49	21.49	ULTIMA 5 CGA/EGA	21.49	21.49
		CGA/EGA	18.49	18.49	ULTIMA 6 M/CGA/EGA/VGA	18.49	18.49
		CGA/EGA	10.49	10.49	ULTIMA TRILOGY (1, 2 AND 3) (CGA/EGA)	18.49	18.49
		CGA/EGA	10.49	10.49	UMS CIVIL WAR DISK CGA/EGA	10.49	10.49
		CGA/EGA	13.49	13.49	UMS VIETNAM DISK CGA/EGA	13.49	13.49
		CGA/EGA	16.49	16.49	VOYAGER CGA/EGA	16.49	16.49
		CGA/EGA	15.99	15.99	WAR IN MIDDLE EARTH CGA/EGA	15.99	15.99
		CGA/EGA	14.49	14.49	WAYNE GRETZKY HOCKEY CGA/EGA/VGA	14.49	14.49
		CGA/EGA	21.99	21.99	WISBRINGER (INFOCOM)	21.99	21.99
		CGA/EGA	18.49	18.49	WOLFPACK CGA/EGA/VGA	18.49	18.49
		CGA/EGA	18.49	18.49	WORD WIZARD 2	18.49	18.49
		CGA/EGA	33.99	33.99	WORLD ATLAS	33.99	33.99
		CGA/EGA	15.99	15.99	WORLD CUP SOCCER-ITALIA 90	15.99	15.99
		CGA/EGA	13.49	13.49	YES CHANCELLOR! (ECONOMY SIM) CGA/EGA	13.49	13.49
		CGA/EGA	16.99	16.99	ZOMBIE	16.99	16.99
		CGA/EGA	16.49	16.49	ZORK 2 (INFOCOM)	16.49	16.49
		CGA/EGA	18.49	18.49	ZORK 3 (INFOCOM)	18.49	18.49

OR JOIN EUROPE'S BIGGEST ADVENTURE CLUB

## OFFICIAL SECRETS

FOR ADVENTURES & ROLE PLAYING & MORE

All the benefits of Special Reserve plus:

**Confidential.** Our 32 page bi-monthly magazine is essential reading for those interested in adventures or role playing games. Written by experts, *Confidential* has covered everything from How to Host a Murder to Which F16 Flight Simulator? Our agents, led by the Master Spy known as "The Boss Upstairs", seek out the secrets of RPG's, FRP's, MUG's, PBM's, Leisure Suit Larry, The Russians, Elvira..... and more.

**Myth.** Written by Magnetic Scrolls, authors of The Pawn, exclusively for members of Official Secrets. Myth is a small adventure set

in Ancient Greece. In it you'll meet The Ferryman, cheat Death and face the nine-headed Hydra. Myth includes the famous Magnetic Scrolls parser and graphics and is included in the price of membership.

**Amiga Format said:**

"An excellent adventure... witty, cunning and just plain good fun! If you liked Fish! you'll probably like this, because they're very similar in style: you may even prefer Myth, it's that good!"

Myth Ratings: Crash 91%, CU 90%, Amiga Format 87%, TGM 85%

**Sim City or Drakkhen** rrp 29.99. Choose one free with membership.

**Of Drakkhen, ST Action said:** "Drakkhen really impressed me. For

me, the game was a subtle cross between my all-time favourite, Dungeon Master, and the SSI fantasy role-playing games. The graphics are superb.... Overall, Drakkhen is an excellent RPG, one that will take quite some time to beat" and **Zero said:** "Absolutely brilliant".

**Of Sim City, ACE said:** "Sim City is a politician's - or a gamesplayer's - dream... comparisons spring immediately to mind with

Populous... but Sim City seems to have much more depth..." and **C&VG said:** "Sim City is utterly fab"

**Help-Line.** Manned weekdays until 8pm and Sundays - with solutions to most adventures.

**Annual Membership to Official Secrets**

With 6 issues of Confidential, Myth, Drakkhen or Sim City, Help-Line and membership of Special Reserve. **27.99**



## SALES LINE 0279 600204.

### IBM Mega-Savers

DISK 5.25 3.5

APACHE STRIKE CGA/EGA	6.99	KRISTAL	10.49	10.49
ARCHIPELAGOS CGA/EGA	7.99	KULT CGA	6.99	8.49
AUSTERLITZ (BATTLE OF)	15.49	LANCELOT CGA/EGA	9.49	
BAR GAMES	6.99	LOMBARD RAC RALLY	10.99	10.99
BORDER ZONE (INFOCOM)	8.99	LURKING HORROR	8.99	
BUREAUCRACY (INFOCOM)	8.49	MENACE EGA	7.49	7.49
CLOUD KINGDOMS	8.49	MICROPROSE SOCCER M/CGA/EGA/VGA	8.99	8.99
CONFLICT EUROPE CGA/EGA	6.49	MILLENNIUM 2.2 CGA	6.49	
CONFLICT IN VIETNAM	7.49	NORTH & SOUTH CGA/EGA	10.49	10.49
CORRUPTION (M/SCROLLS)	10.99	PAWN (M/SCROLLS)	10.99	10.99
DEFENDER OF THE CROWN	8.99	PLANETFALL (INFOCOM)	9.99	
DON'T GO ALONE	7.49	PURPLE SATURN DAY CGA/EGA	8.49	8.49
DRAKKHEN CGA/EGA	13.99	ROCKET RANGER CGA/EGA	7.99	7.99
EDDIE EDWARDS SUPER SKI	4.99	SENTINEL CGA/EGA/VGA	9.99	
ELITE M/CGA/EGA	5.99	SHERLOCK (INFOCOM)	9.99	
EYE OF HORUS CGA/EGA	8.99	SIM CITY CGA/EGA	13.99	13.99
F16 FALCON CGA	11.49	SINBAD (CINEMAWARE)	6.99	6.99
F16 FALCON EGA	17.99	SOLO FLIGHT (FLIGHT SIM)	6.99	
FISH! (M/SCROLLS)	10.99	SPEEDBALL CGA/EGA	5.99	5.99
FOOTBALL MANAGER 2+		SPITFIRE ACE	8.99	
EXPANSION CGA/EGA/VGA	10.99	STAR RAY	7.49	
FOOTBALL MANAGER		STARGLIDER CGA/EGA	6.99	
WORLD CUP EDITION	10.99	STRIKE FORCE HARRIER	6.99	
FUN SCHOOL 2 (2-8) CGA/EGA	8.49	TEENAGE QUEEN (STRIP POKER) M/CGA/EGA	9.49	9.49
FUN SCHOOL 2 (6-8) CGA/EGA	8.49	TETRIS CGA/EGA	5.99	
FUN SCHOOL 2 (8+) CGA/EGA	8.49	THIRD COURIER	7.49	7.49
GAMES WINTER EDITION	8.49	THREE STOOGES (CINEMAWARE) CGA/EGA	6.99	6.99
GOLD RUSH! M/CGA/EGA/VGA	8.99	THUNDER CHOPPER	6.49	
GUILD OF THIEVES	10.99	TIME & MAGIC (LEVEL 9)	10.49	
HARD BALL 2	6.99	TOMAHAWK CGA/EGA	6.49	
HELLCAT ACE	6.99	UMS - UNIVERSAL MILITARY SIMULATOR CGA/EGA	7.49	

\* SHEKHANA COMPUTERS : ESTAB SINCE 1978 \*

\* ACCESS - ORDER BY CREDIT CARD 081-348-2907/081-340-8565 - VISA

SOFTWARE TITLE	ATARI ST	CBM AMIGA	SOFTWARE TITLE	ATARI ST	CBM AMIGA	***ACCESSORIES***	Shinobi	World Bowling
1ST Word Plus	39.99		Photom Paint 2.0		19.99	1084 Monitor	29.99	24.99
Addis Football	19.99	19.99	Player Manager	15.99	15.99	14" Screen Filter	29.99	***SEGA 16-BIT***
Ageis Sonix		39.99	Pro Tennis Tour	19.99	19.99	1/2 Meg Upgrade	39.99	SEGA SYSTEM + FREE GAME
Amos Sound Digitizer		89.99	Rainbow Islands	15.99	19.99	Super Darius - CD	34.99	SEGA SYSTEM + FREE GAME
Amos Games Creator		39.99	Robocop	15.99	19.99	Super Dodge Ball	34.99	+ 2 CONTROL PADS
Anarchy	19.99	19.99	Shadow of the Beast	19.99	19.99	Super Volleyball	29.99	JoyPad Deluxe
A-Max + Rom		179.99	Sherman M4	15.99	19.99	Tiger Road	29.99	Joystick XE-1 ST
Back to the Future 11	19.99	19.99	Sim City	24.99	24.99	Vigilante	29.99	Platz Grip JStick
Batman - Movie	15.99	19.99	Sly/Spy	15.99	15.99	World Court Tennis	29.99	Power Supply Unit
Blade Warrior	19.99	19.99	Space Ace	39.99	39.99	***SEGA 8-BIT***		Afterburner 11
Blade Warrior	19.99	19.99	Stos	24.99		Sega Master System	79.99	Air Diver
Boxing Manager	15.99	15.99	Superbase 2		39.99	Sega Control Stick	14.99	Alex Kidd
Bridge Player 2000	15.99	15.99	Tennis Cup	15.99	19.99	Quickshot Joystick	14.99	Altered Beast
Chaos Strikes Back	19.99	19.99	The Beast	19.99	27.99	California Games	25.99	Assault Suit Leynos
Conqueror	19.99	19.99	Their Finest Hour	24.99	24.99	Chase HQ	25.99	Batman
Cyberball	15.99	19.99	Time Soldier	15.99	19.99	Double Dragon	29.99	Curse
Damocles	19.99	19.99	Triad Vol 3	24.99	24.99	Dynamite Dur	29.99	Curse
De Luxe Paint 2		29.99	T.V. Basketball	19.99	24.99	Galaxy Force	29.99	DJ Boy
Deluxe paint 111		69.99	Ultima 5	24.99	24.99	Golden Axe	25.99	Forgotten Worlds
Deluxe Video 3		79.99	Winners - U.S. Gold	23.99	23.99	Operation Wolf	25.99	Ghouls + Ghosts
Dragons Breath	24.99	24.99	Workbench 1.3	15.99	15.99	Psycho Fox	25.99	Ghostbusters
Dungeon Master	19.99	24.99	World Cup Soccer 1990	14.99	14.99	RO Grand Prix	25.99	Golden Axe
F16 Falcon	19.99	23.99				R-Type	25.99	Herzog Zwei
F16 Falcon	19.99	19.99				Tennis Ace	25.99	Kiryakoe King 11
F16 Combat Pilot	19.99	19.99				Wonderboy 111	25.99	New Zealand Story
Fighter Bomber	24.99	24.99				World Games	29.99	Rambo 3
Fight Simulator 2	27.99	27.99				World Soccer	24.99	Sokoban
Foot Man, World Cup	15.99	15.99				Zip Stick Auto	14.99	Space Harrier 11
F19 Stealth	29.99	29.99						Super Thunderblade
F-29 Retaliator	19.99	19.99						Super Baseball
Hawaiian Scenery	15.99	15.99						Super Hylics
Home Accounts	23.99	23.99						Super Basketball
It Came From The Desert		24.99						Super Hang on
Italia 1990	4.99	4.99						Super Shinobi
Italy 90	19.99	19.99						Tatsujin
Ivanhoe	15.99	19.99						Thunderforce 11
Kick Off 2	19.99	19.99						Thunderforce 3
Killing Game Show	19.99	19.99						Whip lash
Kind words V2		39.99						
Klax	14.99	14.99						
Leisure Larry 3		34.99						
Lost Patrol	15.99	19.99						
Magnum 4	24.99	24.99						
Manic Mansion	19.99	19.99						
Micropro Soccer	19.99	19.99						
Leisure Larry 3		34.99						
Lost Patrol	15.99	19.99						
Magnum 4	24.99	24.99						
Manic Mansion	19.99	19.99						
Micropro Soccer	19.99	19.99						
Mid Winter	24.99	24.99						
Mini Genlock		79.99						
Music - X		149.99						
Photom paint		14.99						

**★ SPECIAL OFFER ★**

**JVC 3.5" DSDD  
BOX OF 10 DISKS £8.99**

**TOK 3.5" DSDD MULTI COLOURED  
FREE STORAGE BOX OF 10 DISKS  
£9.99**

**3.5" DSDD BOX OF 10 SONY  
UNBRANDED  
£5.99**

**5.25" JVC DSDD BOX OF 10 DISKS  
£4.99**

<b>3.5" X 40 BOX</b>	<b>£4.99</b>
<b>3.5" X 80 BOX</b>	<b>£6.99</b>
<b>5.25" X 40 BOX</b>	<b>£6.99</b>
<b>5.25" X 80 BOX</b>	<b>£9.99</b>

**PERSONAL CALLERS** Can purchase software at our branch at 2 Gladstone House, High Rd. Wood Green, N22 (opp Top Rank Club) Tel: 081-859-9412 ABOVE ARE MAIL ORDER PRICES ONLY. 221, Tottenham Court Rd, London W1R9AF (near Goudge St tube station) Tel: 071-631-4 627

**MAIL ORDER CUSTOMERS** CHQ P.O. Payable to: S.C.S. (ACE), 605 Green Lanes, London N18 0DY P-P add 50p per software + £1.00 for accessories. £5.00 for machines. EEC add £1.00 per item, elsewhere add £2.00 per item for annual. Please specify machine type in order. New releases will be sent to you on day of release. E & O E Tel: 081-340-8565, 01-348-2907, FAX: 081-889-9413

**ACCESS AND VISA CARDS ACCEPTED** Credit card orders despatched same day subject to availability. Tel: 081-348-2907, 340-8565 Fax: 081-889-9413 Licensed credit Brokers. Trade enquiries welcome.



**PC SUPER GRAFX**

<b>PC ENGINE</b>	
<b>PC ENGINE CORE GRAFX</b>	
PAL inc free game	£169.95
SCART inc free game	£165.95
<b>PC ENGINE SUPER GRAFX</b>	
PAL inc free game	£279.95
SCART inc free game	£269.95
<b>CD ROM PLUS</b>	
<b>INTERFACE</b>	£299.00
<b>PC ENGINE GAMES</b>	
DRUNKEN MASTER	16.90
TALE OF THE MONSTERPATH	16.90
WONDERBOY	16.90
GALAGA 88	19.90
DRAGON SPIRIT	19.90
SPACE HARRIER	19.90
MOTO ROADER	19.90
R-TYE 1	24.90
VIGILANTE	22.90
FANTASY ZONE	22.90
VICTORY RUN	24.90
NAMCOT BASEBALL	24.90
PACLAND	25.90
WORLD COURT TENNIS	29.90
R-TYPE II	31.90
LENGENDARY AXE	31.90
SON SON II	29.90
NAXAT OPEN	29.90
DUNGEON EXPLORER	29.90
P-47	31.90
SIDE ARMS	32.90
CYBER CROSS	31.90



NINJA WARRIORS	31.90
BLOODYWOLF	31.90
BREAKIN' BILLARDS	31.90
TIGER HELI	32.90
ORDYNE	32.90
GUNHEAD	32.90
DORAEMON	31.90
DIGITAL CHAMP	31.90
ALTERED BEAST	32.90
USA BASKETBALL	32.90
PC KID	32.90
F1-TRIPPLE BATTLE	32.90
KNIGHT RIDER	32.90
HEAVY UNIT	32.90
VOLFIED	32.90
MR HELI	32.90
SHINOBI	32.90
TAITO MOTORBIKE	
RACING	32.90
WRESTLING	32.90
CHASE HQ	33.90
TIGER ROAD	33.90
ATOMIC ROBO KID	33.90
NEW ZEALAND STORY	33.90
SPLATTER HOUSE	33.90
BULL FIGHT BOXING	33.90
PARANOIA	33.90
SUPER VOLLEYBALL	33.90
SPACE INVADERS PLUS	33.90
ARMED FORMATION	33.90
POWER DRIFT	33.90
DOWN LOAD	33.90
CYBERCORE	33.90
PSYCHO CHASER	33.90

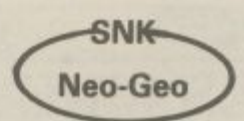

SUPER SAMURI	33.90
BARUMBA	33.90
IMAGE FIGHT	TBA
OPERATION WOLF	TBA
AFTERBURNER	TBA
<b>CD ROM GAMES</b>	
STREET FIGHTER	33.90
ALTREDED BEAST	33.90
WONDERBOY III	33.90
SIDEARMS SPECIAL	33.90
VARIOUS II	33.90
RED ALERT	33.90
FINAL ZONE II	33.90
BASEBALL	33.90
SUPER DARIUS	33.90
<b>SUPER GRAFX</b>	
BATTLE ACE	33.90
GRANZORT	33.90
GHOULS 'N' GHOSTS	TBA
STRIDER	TBA
<b>SEGA MEGADRIVE</b>	
PAL inc. 1 game	£179.95
SCART inc. 1 game	£169.95
<b>SEGA MEGADRIVE GAMES</b>	
ALEX KID	24.90
MR KOMATSU	24.90
ALTERED BEAST	29.90
SUPER THUNDERBLADE	31.90

SPACE HARRIER II	31.90
THUNDERFORCE II	32.90
WORLD CUP SOCCER	32.90
GOLF SUPER MASTERS	32.90
GHOULS 'N' GHOSTS	37.90
RAMBO III	33.90
LAST BATTLE	33.90
SUPER HANG ON	33.90
FORGOTTEN WORLDS	33.90
TATSUJIN	31.90
KUJAKIHU II	31.90
SOKO BAN	32.90
ZOOM	32.90
GOLDEN AXE	34.90
CURSE	32.90
FINAL BLOW	34.90
SUPER DARWIN	33.90
ASSAULT SUIT LEYNOS	33.90
AFTER BURNER II	34.90
DJ BOY	33.90
WHIP RUSH	34.90
THUNDERFORCE III	36.90
GHOSTBUSTERS	34.90
SUPER MONACO GP	JULY
INSECTOR X	JULY
E-SWAT	TBA
BATMAN	TBA
<b>SNK NEO-GEO</b>	
NEO-GEO	£450
BASEBALL	£199
GOLF	£199
NAM 75	£199
MAGICIAN LORD	£199

Please make cheques and P/O's payable to: NEW WORLD CONSOLES, 61 Stainmore Road, Bedford MK41 0PZ. Tel: (0234) 266352. Please add £1.00 p&p for games and £5.00 for machines.





# HOT OFF THE SHELF

OK, SO SUMMER IS HERE. THE LAST THING YOU WANT TO BE DOING IS SITTING INDOORS GETTING ALL HOT AND STICKY OVER A COMPUTER GAME. NO, YOU WANT TO BE OUT THERE ON THE BEACH, GETTING A TAN, STRUTTING AROUND IN YOUR TOM CRUISE SHORTS, OR YOUR ROLL-DOWN BIKINI, GENERALLY LOOKING COOL AND HAVING A GOOD TIME. BUT, WE ALL KNOW WHAT SUMMERS CAN BE LIKE DON'T WE? JUST AS YOU'VE GIVEN YOURSELF A HERNIA STRUGGLING INTO LAST YEARS BATHING COSSIE (NOW TWO SIZES TOO SMALL), THERE IS A TINY PITTER-PATTER, EVERYTHING GOES GREY, AND DOWN IT COMES (NOT THE BATHING COSSIE STUPID!). SO JUST IN CASE THE DREADED RAIN STRIKES AGAIN YOU HAD BETTER GET STOCKED UP ON A FEW GOOD GAMES, AND OUR ACE GUIDE TO THE LATEST AND GREATEST IS THE PLACE TO START LOOKING...

## ANTHEADS

Cinemaware/Mirrorsoft • Amiga £14.99dk  
For all those who loved *It Came From The Desert* here is more of the same in the shape of a handy bolt-on scenario. It's fifties style Sci-Fi again, and this time some very strange things are happening to the inhabitants of the tiny Mid-West American town of Lizard's Breath. You play 'Brick' Nash, an ex-fighter pilot determined to solve the riddle of the Antheds. If you enjoy puzzle solving with great graphics and sound, then you can't go far wrong with this number, and if you haven't played *It Came From The Desert* then why not give that a try first?  
★ ACE RATING 902

## BATMAN

US Gold • Atari ST £19.99dk • Amiga £24.99dk • Spectrum £9.99cs £14.99dk • C64 £9.99cs £14.99dk  
The game of the movie. Michael Keaton put up a pretty good show as the caped crusader in the film, and his digital counterpart isn't too bad either. There are no less than five sections to the game. The first, Axis Chemical Plant, and last, Gotham City Cathedral, are superb 2D platform games in which our hero has to swing around on his batrope bumping off the villains before they get him. There is also a brain game in the Batcave and two excellent 3D games set in the Batmobile and Batwing respectively. A must for all DC comic fans.  
★ ACE RATING 922

## BOMBER

Activision • Atari ST £24.99dk • Amiga £24.99dk • Spectrum £14.99cs £19.99dk • Amstrad £14.99cs £19.99dk • C64 £14.99cs £19.99dk • PC £34.99dk  
A flight sim employing fast solid vector graphics with more bells and whistles than most similar programs. There are a total of fourteen fighter bombers from around the world featured in the program. If you get bored of the standard forward cockpit view then it is possible to select one of a variety of out of cockpit views. The PC version is an experience not to be missed (providing you have a 286 or 386 machine with EGA or VGA), but for all the other versions - try before you buy!  
★ ACE RATING 925

## CHAOS STRIKES BACK

FTL/Mirrorsoft • Atari ST £24.99 • Amiga TBA  
The long awaited sequel to *Dungeon Master*. If you have already played through the first program you can use your existing characters, otherwise there is another hall of mirrors you can select from. Chaos has a similar feel to *Dungeon Master*, but is much tougher. There are also some new features thrown in, like a character editor and help oracle (very handy). If you haven't played *Dungeon Master* then play that first before making a definite date with this game.  
★ ACE RATING 945

## CONQUEROR

Rainbow Arts • Atari ST £19.99dk • Amiga £24.99dk • PC £24.99dk  
An arcade style tank sim which makes use of a 3D graphics system based around the one David Braben developed for *Zarch*. There are three types of game available: arcade, attrition, and strategy. All three are best played with two joysticks *Battlezone* style, but there are enough control options to suit every set-up. A definite buy for tank buffs.  
★ ACE RATING 925

## DAMOCLES

Novagen • Atari ST £24.95dk • Amiga £24.95dk • PC TBA  
This unusual combination of flight sim and adventure game, and sequel to the well-received *Mercenary*, has been in development for a couple of years now, but the resulting game has been worth the wait. The wireframe graphics of the original game have been replaced by solid 3D vector graphics, but they are just as fast. There are now nine planets to explore instead of one city, so there is plenty of long term challenge here.  
★ ACE RATING 935

## FUTURE WARS

Palace • Atari ST £24.99dk • Amiga £24.99dk • PC TBA  
A totally mouse-driven graphic adventure from French developers Delphine. You are cast as a mild-mannered office window cleaner who gets caught up in an alien plot to conquer Earth in the 43rd century. The graphics and

background music are very striking and the game is made very accessible by the lack of text entry. There is enough of a challenge here to keep most adventurers happy for some time. A delightful game.  
★ ACE RATING 910

## GRAVITY

Imageworks • Atari ST £24.95dk • Amiga £24.95dk • PC TBA  
Deep space strategy unlike anything you've ever seen before. The universe is being invaded by the alien outies who are attempting to turn all the suns in the universe into black holes. Meanwhile you must create as many inhabitable systems as possible. The game makes use of the principle of Einstein-Minkowski fourspace - this makes for some very unusual graphics. When you add programmable drones and travel via black holes you have yourself a highly original and compelling game.  
★ ACE RATING 930

## HARD DRIVIN'

Domark • Atari ST £19.99dk • Amiga £19.99dk • Spectrum £9.99cs £14.99dk • Amstrad £9.99cs £14.99dk • C64 £9.99cs £12.99dk • PC £24.99dk • Archimedes £30.00dk  
A very competent conversion of the Tengen coin-op. Drive your Ferrari round either a speed track or a stunt track complete with a loop and open bridge to leap. The coin-op scored on its super fast solid vector graphics, and these have been faithfully reproduced in

the computer versions. A must buy.

★ ACE RATING 937

## HARPOON

Mirrorsoft/PSS • PC £29.99dk  
Quite simply the best naval simulation to be released for the General Public. The battleset that comes with the game deals with East-West conflict in the North Sea, but other battlesets will be available soon. A clever system of three map types is used to effectively manage each mission. The nice thing about *Harpoon* is that the computer takes care of all the boring mechanics, allowing you to concentrate on broad tactics. A must buy for anyone interested in modern naval warfare.  
★ ACE RATING 940

## INDIANAPOLIS 500

Electronic Arts • PC £24.95  
The ultimate racing game. *Indy 500* uses state of the art solid vector graphics which really add something to the high speed action. As in Activision's *Bomber* there are a variety of out-of-cockpit views to select from. The realistic handling of the cars will have you coming back to this game time and time again.  
★ ACE RATING 935

## INTERPHASE

Imageworks • Atari ST £24.99dk • Amiga £24.99dk • PC £24.99dk  
Your task is to guide a female saboteur to the heart of the Dreamtrack Corporation by interacting with a strange 3D

Continued on page 110



### ● CLASS OF THE 90's ●

Amiga A500 Educational Pack with Word Processing, Art and Design, Maxiplan 500, Publishers Choice, Amiga Logo, the list goes on.  
**OUR PRICE £545.00**

**Commodore 64 World Cup pack.** Includes C64 Computer with cassette unit. Two joysticks and features the amazing Adidas World Championship football. Plus Beach Volley, Pro Tennis, Basketmaster etc.  
**OUR PRICE £149.50**

**Commodore 64 Light Fantastic Pack.** Includes C64 Computer with cassette unit, light gun, 3D glasses and ten games. Plus toolbox tape with Art package etc.  
**OUR PRICE £149.50**

**Software** all current titles  
48 Hour Delivery  
**P.O.A.**

● ALL PRICES INCLUDE VAT ● ALL PRODUCTS CARRY UK SPECIFICATION ●

### SUMMER SIZZLER

**BATMAN PACK ● FLIGHT OF FANTASY**  
ONLY \* **£299 Inc. VAT** \* ONLY

When you purchase any 10 Titles at £9.95 each from the following Selection.

1 Micro Prose Soccer	7 Dominator	13 Saint & Greavsie	19 Galaxy Force
2 Battle Valley	8 Cybonod II	14 Espionage	20 Archipelagos
3 Star Blaze	9 Frost Byte	15 Exolon	21 Blasteroids
4 Running Man	10 Mouse trap	16 Knight Orc	22 Crunches Factory
5 Warp	11 Ice Hockey	17 President is Missing	23 Pacland
6 Eye of Horus	12 Slayer	18 Thai Boxing	24 Karting Grand Prix

You also get the following items free

Mouse Mat ● Dust Cover ● Joystick ● 10 Blank Discs

(Titles may change subject to stock without notice)

### ACCESSORIES

MONITOR STANDS FROM	£ 16.95
3.5" BLANK DISKS FROM	£0.70 Each
5.25" BLANK DISKS FROM	£0.70 Each
3.5" DISK BOXES FROM	£1.95
5.25" DISK BOXES FROM	£6.95
PRINTER LEADS FROM	£4.95
DUSTCOVERS FOR PRINTERS AND MONITORS FROM	£4.95
WE STOCK A FULL RANGE OF JOYSTICKS PRICES START FROM A LOW	
DESIGNS INCLUDE KONIX, QUICKSHOT, CHEETAH AND CRUISERS	£3.95
WE HAVE THE FOLLOWING SOFTWARE OFFERS	
KINDWORDS	£ 44.95
● SPRITZ PAINTPACK	£9.95 NORMALLY £ 29.95 ●
● SUPERPLAN SPREADSHEET	£69.95 NORMALLY £99.95 ●
● SUPERBASE PERSONAL II	£69.95 NORMALLY £99.95 ●
● SUPERBASE PROFESSIONAL	£149.95 NORMALLY £249.95 ●

### STAR PRINTERS

LC10 MONO 9PIN 144 CPS	£148.95
LC10 COLOUR 9PIN 7 COLOURS	£194.95
LC2410 24PIN 170 CPS	£239.95
XB2410 24PIN 240 CPS	£448.31
WITH COLOUR KIT	£489.95
XB2415 15" CARRIAGE	£590.51
PRINTER RIBBONS FOR STAR PRINTERS FROM	£4.95
LASER SERIES	P.O.A.
AUTO SHEET FEEDERS AVAILABLE ON ORDER	

### PANASONIC PRINTERS

KXP1081 9PIN 120 CAP NLQ	£138.00
KXP1124 24PIN 120 CAP NLQ	£285.00
KXP1540 WIDE CARRIAGE	P.O.A.

### EPSON PRINTERS

EPSON LX850 9PIN	£210.00
EPSON LQ550 24PIN	£310.00

### OTHERS

SEIKOSHA SP180	£118.00
CANON PW1080	£139.00
CITIZEN 120D	£124.95
CITIZEN HQP40	£299.00
AMSTRAD DMP3160	£119.00

### MONITORS

1084SD STEREO COLOUR	£247.50
8833 STEREO COLOUR	£265.00

### DRIVES & RAM EXTENSIONS ETC

A501 RAM EXPANSION	£ 89.00
512 RAM EXPANSION	£ 85.00
MDC30 EXT 3.5" DRIVE	£ 79.00
A1010 EXT 3.5" DRIVE	£ 85.00
CUMANA CAS354 EXT DRIVE	£ 79.00
C64 1541 C11 EXT 5.25"	£120.00
A590 20Mb HARD DISK	£375.00
1352 MOUSE	£ 29.95
IBM HANDY MOUSE	£34.00
AMIGA 2300 GENLOCK	£208.10
GENIUS MOUSE IBM	£ 38.95
SPIKE SURGE PROTECTOR	£ 10.95

To: 42-44 Millbrook Road East, Southampton

I wish to order .....

I enclose cheque/PO for £ ..... inc. VAT

Or charge my Access/Visa No.      Expiry date ...

.....

Name ..... Signature .....

Address .....

Postcode ..... Tel. No: .....

PRICES CORRECT ON DATE GOING TO PRESS      ACE

● DELIVERY CHARGE £10 COURIER ● ALL PRICES CORRECT AT GOING TO PRESS ●

### ● CLASS OF THE 90's ●

Amiga A500 Educational Pack with Word Processing, Art and Design, Maxiplan 500, Publishers Choice, Amiga Logo, the list goes on.  
**OUR PRICE £545.00**

**Commodore 64 World Cup pack.** Includes C64 Computer with cassette unit. Two joysticks and features the amazing Adidas World Championship football. Plus Beach Volley, Pro Tennis, Basketmaster etc.  
**OUR PRICE £149.50**

**Commodore 64 Light Fantastic Pack.** Includes C64 Computer with cassette unit, light gun, 3D glasses and ten games. Plus toolbox tape with Art package etc.  
**OUR PRICE £149.50**

Megaland can also supply a complete range of personal computers including Amstrad, Commodore, Hyundai and Olivetti.  
**P.O.A.**

# LOOK OUT FOR OUR SUMMER SIZZLERS

# M E G A L A N D

# NAUGHTY JOKE LINE



0898 800 205

**JOKE OF THE CENTURY**  
0898 800 206



**FAT FREDA'S RUDE JOKES**

0898 800 207

GORDON THE GOALIE'S FOUL! FOOTY JOKES



0898 800 208

**AUSSIE NAUGHTY JOKES**  
0898 800 209

TASTELESS TIM'S BAD TASTE JOKES



0898 800 210

**ROGER SMELLEE**  
0898 800 211

5p PER 12 SECS CHEAT RATE 5p PER 8 SECS ALL OTHER TIMES INC VAT  
ULTRA NAUGHTY LINE FOR READERS OF SMALL PRINT 0898 800 212

## THE HI-TECH GAMES ZONE

Console & 16 Bit Specialists.

Sega Megadrive, PC Engine, Atari Lynx, Nintendo Entertainment System, Sega Mastersystem, Atari 2600 & 7800 systems, Game & Watch Handhelds, Amiga, Atari ST & IBM PC Software & Hardware.

★ SEGA MEGADRIVE £169.99 + £3.50 p&p ★

Send SAE and tell us which machine/s you are interested in. We'll send you a detailed catalogue by return post!!

Or leave your name & address on our 24 hour answerphone service (Number below).

Open 7 days a week 10am-7pm. 24 hour answerphone.

The Hi-Tech Games Zone, P.O Box 13, Feltham, Middlesex, TW14 8BG

The HI-TECH GAMES ZONE is a fully Authorised Nintendo Dealer (Supported by SERIF, the UK Distributors of NINTENDO)

IBM • AMIGA • C-64 DISC • ST

# STRATEGIC PLUS

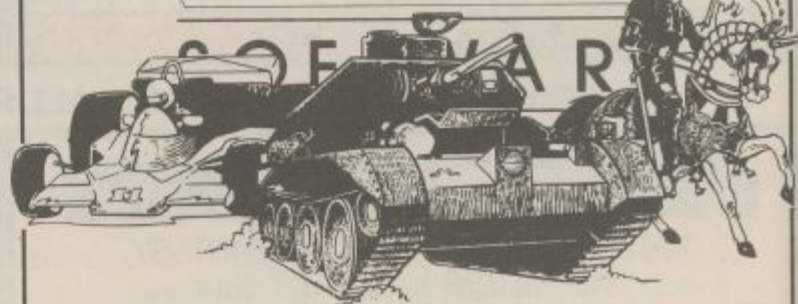

## WAR GAMES ADVENTURE GAMES SIMULATORS & SPORTS

STRATEGIC PLUS SOFTWARE

Strategic Plus Software

PO Box 8, Hampton, Middx TW12 3XA

Telephone 01 941 6163

Send £2.50 for Extensive Catalogue

Proprietor Mr. S. Harper

9AM - 6PM

0784 48 3524

# MUTANT SOFTWARE

THURS FRI SAT  
7PM 01 - 890 3296 7AM

### UNBRANDED BLANK DISCS

10DSDD .....	7.50
20DSDD .....	14.00
30DSDD .....	19.50
40DSDD .....	24.00
50DSDD .....	27.50

### JOYSTICKS

KONIX SPEEDKING A/F .....	9.99
KONIX NAVIGATOR .....	11.99
QUICKJOY SUPERBOARD .....	18.50
COMP PRO 5000 .....	14.99
QUICKSHOT II TURBO .....	8.99

### SOFTWARE AMIGA ATARI

F29 RETALIATOR	16.99	16.99
RAINBOW ISLANDS	16.50	13.99
DAN DARE III	14.50	14.50
WIPE OUT	14.50	14.50
NORTH AND SOUTH	15.50	15.50
X OUT	14.50	14.50
STUNT CAR RACER	16.50	16.50
OPERATION THUNDERBOLT	16.50	14.50
DRAGONS BREATH	18.50	18.50
TV SPORTS BASKETBALL	18.50	
HOUND OF SHADOW	16.99	16.99
PRO TENNIS TOUR	16.50	16.50
FUTURE WARS	16.50	16.50
KICK OFF 2 (END OF MAY)	14.50	14.50
THE UNTOUCHABLES	16.50	14.50
GHOULS + GHOSTS	16.50	14.50
DRAKKHEN	18.50	18.50
IT CAME FROM DESERT	18.50	
ANTHEAD (DATA)	10.50	
SIM CITY	18.50	18.50
MIDWINTER	18.50	18.50
CYBERBALL	13.99	13.99
PLAYER MANAGER	14.50	14.50

### HARDWARE + PERIPHERALS

AMIGA 500 FLIGHT OF FANTASY .....	399.00
\$MEG ONLY .....	69.99
\$MEG WITH CLOCK .....	74.99
RF 302 C DISK DRIVE .....	69.99
PHILIPS COLOUR MONITOR .....	269.00

### SPECIAL MUTANT PACKS

PRO TENNIS TOUR	
FUTURE WARS	
F29 RETALIATOR .....	49.99
CYBERBALL	
RAINBOW ISLANDS	
WIPE OUT .....	44.99
KICK OFF	
PLAYER MANAGER	
XTRA TIME .....	34.99
CHRONOQUEST II	
MIDWINTER	
MANCHESTER UTD .....	52.50
TV SPORTS BASKETBALL	
CHASE HQ	
PIPEMANIA .....	49.99

ALL PRICES INCLUDE FREE DELIVERY WITHIN 24hrs IF IN STOCK. RING FOR AVAILABILITY

MUTANT SOFTWARE  
475 STAINES ROAD

081	BEDFONT	081
890	MIDDX	890
0900	TW14 8BL	3296

CHEQUES + PO MAKE PAYABLE TO MUTANT SOFTWARE. ACCESS AND VISA AVAILABLE BY PHONE.

MAIL ORDER TO:- 16 BIT DEPT, 55 HARROW DRIVE, LONDON, N9 9EQ

**HARDWARE:-**

A500 + Modulator + WB 1.3 + Batman the Movie + £100 Software .....	£364.95
A500 + Modulator + F29 + Rainbow Islands + Esc. Planet of Robots .....	£369.95
Atari 520 STFM + 4 Games + STOS + Paint Package .....	£274.95
Atari 520 ST PowerPack inc £500 software .....	£344.95
Free 10 DS/DD and Mouse Mat with above when paying Cheque/Cash	

Amiga 1/2 Meg RAM with Clock .....	£59.99	Panasonic KXP 1081 Printer .....	£149.99
ST/Amiga External Drive .....	£74.99	Commodore 1084S Monitor .....	£249.99

Just in... ATARI LYNX £164.99  
(Portable Colour Entertainment System)  
Software Cartridges from £23.99

QUALITY 3 1/2" DD/DS DISKS  
10 £6.99 30 £19.99 50 £29.99  
All Disks Boxed in 10's (Not Bulk Packed)

**JOYSTICKS/ACCESSORIES :-**

Competition Pro 5000 .....	£11.99	Disk Drive Cleaner .....	£2.99
Competition Pro 5000 Xtra .....	£13.50	Dust Cover .....	£3.99
Cheriah 125 + .....	£7.50	Mouse Mat .....	£1.99
Konix Navigator .....	£10.99	Mouse Holder .....	£5.50
Konix Speedking (Auto) .....	£9.50	Twin Ext Leads .....	£5.50
		40 Cap Box .....	£6.50

**SOFTWARE:-**

<b>ST AMIGA</b>	Fire & Brimstone	ST AMIGA	P. Gascoigne Soccer	15.99	15.99
888 Attack Sub	Flight Command	16.75	Pheton Storm	16.75	16.75
*Adidas Football	*Flight of the Intruder	19.50	Pinball Magic	12.99	12.99
Altered Beast	Ferocious World	15.99	Pipemania	12.99	15.99
American Dreams	Full Metal Planet	13.75	Pirates	16.75	16.75
AMOS	Future Dreams	15.99	Populous	16.75	16.75
A.P.B.	Future Wars	15.99	Promised Lands	7.50	7.50
Bad Company	F29 Retaliator	16.75	Powerdrift	15.99	15.99
Batman the Movie	Galaxy Force	16.75	Pro Tennis Tour	16.75	16.75
Battlehawks 1942	Ghostsbusters II	12.99	*Quarterback	12.99	12.99
Beast Tiger	Ghosts and Goblins	15.99	Rainbow Islands	13.75	16.75
Bloodwych	Gravity	13.75	Resolution 101	16.75	16.75
Bomber	Hammerfist	15.99	Robocop	13.75	16.75
Cabal	Hot Rod	16.75	*Rotax	16.75	16.75
Castle Master	Int 3D Tennis	16.75	R.V.F. Honda	15.99	15.99
Chambers of Shaolin	Interphase	16.75	*Shadow Warrior	13.75	16.75
Chaos Strikes Back	Infestation	15.99	Scramble Spirits	12.99	12.99
Class HQ	Italy 1990	15.99	Sherman M4	13.75	16.75
*Combo Racer	It Came From Desert	16.75	Shinobi	13.75	13.75
Conqueror	Ivanhoe	19.50	Skidz	13.75	13.75
Continental Circus	Jumping Jackson	15.99	Sim City	16.99	19.50
Crack Down	Kick Off II	12.99	Sim City - Editor	12.99	12.99
Cyberball	Knights of Crystalion	12.99	Sinder	13.75	16.75
Dan Dare III	*Last Ninja II	15.99	Star Wars Trilogy	15.99	15.99
Double Dragon 2	Lazer Squad	13.75	Styx	12.99	12.99
Dragon Ninja	Leisure Suit Larry 3	16.75	Stunt Car	15.99	15.99
Dragon Spirit	Licence to Kill	13.75	Super Wonder Boy (Ltd)	12.99	9.99
Dragon's Breath	Light Force	12.99	Super Cars	12.99	12.99
Drashen	*MI Tank Platoon	16.75	Switchblade	12.99	12.99
Drivin Force	Magnus 4	16.75	*The Lost Patrol	15.99	15.99
*Dynamic Debugger	Man Utd	16.75	Ther Fastest Hour	19.50	19.50
Dynastix Dux (Ltd)	Midwinter	19.50	Theme Park	15.99	15.99
*Dynasty Wars	Moonwalker	13.75	Thunderstrike	15.99	15.99
E Motion	Nevermind	12.50	Toobin	12.99	12.99
*Edition One	New Zealand Story	13.75	Triad III	16.50	16.50
Emlyn Hughes Int. Soccer	Ninja Spirit	13.75	Tower of Babel	15.99	15.99
Esc. Planet of Robots	North & South	16.75	Turbo Outrun	12.99	15.99
Falcon	*Operations Stealth	16.75	Turrican	13.99	13.99
*Falcon Mission II	Operation Thunderbolt	16.75	TV Sports Basketball	12.99	15.99
*F19 Stealth Fighter	PK7	13.75	Untouchables	13.75	16.75
		15.99	Warhead	16.75	16.75
			Xenon II	15.99	15.99
			Xenomorph	15.99	15.99

TEL 081-803-0883 Many more software titles stocked ring for availability. Items marked \* not available at time of going to press. New releases sent on day of release. Stock items are now sent 1st class post by return (FO/CR Card) - Cheque orders please allow clearance. All prices include P+P for UK for mail order only. Visit our shop (Bring this advert to obtain above prices on hardware and 25% off RRP on software e.g. F29 (ST) £18.75).

28A WESTERHAM AVENUE, EDMONTON, LONDON N9

**T.C.COMPUTERS**

12A Barnards Way, Charlton Heights, Wantage, Oxon. OX12 7EB  
Tel : Wantage (02357) 60177

**AMIGA A500**

Amiga A500 Flight of Fantasy Pack .....	£369.00
Amiga A500 Batman Pack .....	£359.00
Amiga A500 Appetizer .....	£379.00
(Word Processor / Paint Program/Music program/Game)	
Amiga A500 inc TV modulator & 2nd Disk Drive .....	£439.00
Amiga A500 1mb Ram inc TV modulator & Game .....	£449.00
Amiga A500 & Colour monitor .....	From £579.00
Amiga A500 System Pack .....	£749.00
(A500/Colour monitor/Printer/The Works software)	
Amiga A500 Class of the 90's Pack .....	£539.00

**AMIGA 2000**

Amiga 2000 Upgrade (PX A500/A100) with 40Mb hard disk .....	£1099.00
Amiga 2000 CPU Base Unit .....	£999.00
Amiga 2000 & Colour monitor .....	£1199.00
Amiga 2000/PC Pack .....	£1525.00
(2000 / Colour / XT Bridge board / 5.25 drive / 20Mb HD)	
Too much to list please call for other systems and prices.	

**PERIPHERALS**

TCAmiga Console for the A500 (Keep things together) .....	£39.99
512K Ram/Clock expansion .....	From £59.00
Commodore A501 Ram/Clock expansion .....	£129.00
Commodore 1084S Colour Monitor .....	£259.00
Philips CM8833 Stereo Colour Monitor .....	£249.00
Cumana CAX 354 1Mb External d'k drive (Disable/Enable) .....	£89.00
NEC or Citizen 1Mb Ex'D'k Drive (Disable Enable & Through) .....	£79.50
Star LC-10 80 col. 144cps. Dot Matrix printer .....	£169.00
Star LC 10 80 col. 144cps. Colour Dot Matrix printer .....	£212.00

Software at up to 30% OFF RRP. Phone for prices.  
All prices inc VAT & are subject to change without notice

**TREBLE**  
*Champions*

A STUNNINGLY REALISTIC  
FOOTBALL STRATEGY GAME



**TREBLE CHAMPIONS -**  
Can YOU Win the League Championship,  
The F.A. Cup and the League Cup?

An Amazing range of Realistic Features  
and Superb Gameplay combine to create  
all the Tension, Drama and Excitement  
of Football Management as you  
compete for Soccer Glory and -  
**THE TREBLE.**

**AN OUTSTANDING RANGE OF FEATURES**

- 4 Divisions of 20 Teams
- Non-League Division of 20 Teams
- Full Home and Away League Programme - 38 Matches
- Results of ALL games for ALL 5 Divisions
- League tables for ALL 5 Divisions
- F.A. Cup including Non-League Teams
- League Cup (1st, 2nd Round and Semi-Final over 2 Legs)
- Promotions and Relegations
- Only 1 Team Promoted from Non-League Division
- Squad of 20 Players and Reserves
- Squad of 15 Players for ALL Other Teams
- Details of over 1900 Players
- Transfer Market - Offer for any Player in any Division
- Transfer Deadline
- Long and Short Term Injuries
- Time management System - limited time for Club management each week
- 2 In-Match Substitutes
- Opposition use Substitutes
- Fitness Training - Keep your Squad at maximum fitness
- Coaching - Improve the Ability of your younger Players and Reserves
- Midweek Matches
- Cup Replays
- Penalty Shoot-Outs
- Player Retirements
- Change Player/Team Names
- Season ticket, Wages, Bank Loans, Interest, Attendance
- SAVE GAME
- 3 Skill Levels
- Start in any Division
- PLUS MUCH MUCH MORE

SPECTRUM SCREEN SHOTS



ALL VERSIONS INCLUDE COMPLETE INSTRUCTIONS

SPECTRUM 48/128K: Tape £9.95. Disk £13.95. COMMODORE 64/128K: Tape £9.95.  
AMSTRAD CPC 464: Tape £9.95. CPC664/6128 Disk £13.95. DISK £12.45.  
ATARI ST: £19.99. AMIGA: £19.99.

AVAILABLE NOW FROM RETAIL OUTLETS  
AND BY MAIL ORDER FROM:

CHALLENGE SOFTWARE, 37 Westmoor Road,  
Enfield, Middlesex, EN3 7LE.

Please make your Cheque or Postal Order payable to  
Challenge Software and state which machine. Orders outside  
U.K. add £1. Add £1.50 for Air Mail outside Europe.

**CHALLENGE**

**SOFTWARE**

TRADE ENQUIRIES WELCOME ON 01 443 1936.

Continued from page 106

environment. The game is very weird and very compelling. It is also very hard – don't expect to get through this one in a hurry.  
★ ACE RATING 915

#### KNIGHTS OF LEGEND

Origin/Mindscape • PC £29.99dk

Role Playing at its best. An expandable game set in the land of Ashtelarea. There are twenty-four quests to complete, or you can simply enjoy exploring. The program stands out because of its attention to detail. There are no less than forty different algorithms to decide how and when an enemy retreats for instance. Impressive stuff.

★ ACE RATING 945

#### KNIGHTS OF THE CRYSTALLION

US Gold • Amiga £29.99dk including musicassette of soundtrack

The most original game that US Gold has released in a long time. It has been marketed as a 'culture simulator', but that doesn't really say much about the game. You play a member of a futuristic community, and your task is to rise to the highest possible status within that culture. This involves playing through several distinct sub-games. The whole is a highly unusual experience with distinct graphics and a superb soundtrack. This certainly won't be to everybody's taste, but if you are looking for something a little different – try this.

★ ACE RATING 935

#### M1 TANK PLATOON

Microprose • PC £39.95dk  
The ultimate tank sim. Not only are there realistic 3D vector graphic sequences with a hell of a lot of atmosphere, but you also have to think carefully about choice of platoons, men, and the way you tackle each scenario. Microprose had to call on the Freedom of Information Act to get all the information that they needed for the game. The result is one of the most

frighteningly accurate tank sims we've seen.

★ ACE RATING 926

#### MIDWINTER

Microprose • Atari ST £29.99dk

The latest mega hit from top programmer Mike Singleton, creator of *Lords of Midnight*. The game is set on a frozen island in the future. Your task is to recruit members of the Peace Force to fight off General Masters' invasion force. This is done by managing people and resources via a series of Fractal Maps and menus. The game has disappointing sound, but nice 3D graphics, and enough solid gameplay to keep you going for months.

★ ACE RATING 948

#### MYTH

System 3 • C64 £9.99cs £14.99dk • Spectrum £9.99cs £14.99dk

The game that pushes the C64 and Spectrum further than they have ever been before. Fight your way through several time zones to reach the ultimate confrontation with the god Dameron. The game is captivating not only because of its size and depth but also because of the superbly animated sprites and sheer playability.

★ ACE RATING 925

#### OPERATION THUNDERBOLT

Ocean • Atari ST £19.99dk • Amiga £24.99dk • Spectrum £9.99cs • Amstrad £9.99cs • C64 £9.99cs

Eminently successful conversion of the hot coin-op hit *Operation Wolf*. Grab your Uzi and shoot your way through hordes of terrorists to rescue the luckless hostages. There are new 3D scenarios this time to add to the frantic lead spitting of the original. Best played with a light gun, but a mouse will suffice if you don't have one. Joystick or keyboard controls don't really cope however.

★ ACE RATING 927

#### PIPEMANIA

Entertainment International • Atari ST £19.95dk •

Amiga £19.95dk • Spectrum £9.99cs £14.95dk • C64 £9.95cs £14.95dk • Amstrad £9.95cs £14.95dk • PC £19.95dk • Macintosh £24.95dk • Archimedes £24.95dk • MSX £9.95cs £14.95dk • BBC/Electron £9.95cs £14.95dk

The game that proves plumbing can be fun. You must construct a continuous length of pipe from several sections before the floop escapes. The action is just as compelling as that in games like *Tetris* and will have you burning the midnight oil in an attempt to beat the odds. It is available for practically every machine, so there is no excuse for not owning a copy.

★ ACE RATING 910

#### PLAYER MANAGER

Anco • Atari ST £19.95dk • Amiga £19.95dk • Spectrum £9.95cs £14.95dk • C64 £9.95cs £14.95dk • Amstrad £9.95cs £14.95dk

*Kick Off* with a management/strategy element. The game is completely icon driven, making it easy to get into. The management detail is superb, right down to planning in-match tactics. And for the match you can either watch from the sidelines or join in with the *Kick Off* style fun.

★ ACE RATING 920

#### PRO TENNIS TOUR

UBI Soft/Blue Byte • Atari ST £24.99dk • Amiga £24.99dk • Spectrum £9.99cs £14.99dk • C64 £12.99cs £16.99dk • Amstrad £9.99cs £16.99dk • PC £29.99dk

One of the best tennis games yet. The control method works really well, although the standard of the computer players is good, so you'll have to put in a lot of practice. There is a choice of grass, concrete, clay, and indoor courts, as well as comprehensive practice options. A good way of spending a few hours while you are waiting for Wimbledon.

★ ACE RATING 900

#### THEIR FINEST HOUR: THE BATTLE OF BRITAIN

Lucasfilm • Atari ST £24.99dk • Amiga £24.99dk • PC £24.99dk  
World War II air combat relived in this superlative flight sim. You have the opportunity to fly a variety of WWII craft from the Spitfire to the Hurricane. A neat option is the camera which records your flight and can be replayed to assess your performance.

★ ACE RATING 933

#### TOWER OF BABEL

Microprose • Atari ST £24.99 • Amiga £24.99  
An imaginative 3D puzzler from Pete Cooke – the man who brought you *Tau Ceti*. You control three robots, a zapper, a grabber, and a pusher. They must be used to complete a specific task on a number of futuristic levels of a tower. This involves working your way past various nasty obstructions deliberately designed to impede your progress. This game will have you burning the midnight oil as you attempt to get past a particularly tricky level.

★ ACE RATING 930

#### ULTIMA VI

Origin/Mindscape • Atari ST TBA • Amiga TBA • PC £34.99dk • C64 TBA  
The ultimate rôle playing game. Sixteen thousand objects, two hundred and fifty characters, unlimited encounters, a quest that will take months to solve, and graphics better than you'll see on any other game of this type. The Ultima series of RPGs go from strength to strength. Join forces with Lord British and once more enter the fray... unbeatable stuff!

★ ACE RATING 950

#### VENDETTA

System 3 • C64 £9.99cs £12.99dk  
A great arcade adventure that really pushes the C64 to its limits. You must fight your way past the terrorists to defuse a bomb, and rescue the professor and his daughter. But while you are on the terrorist's tails

the police are on yours. Most of the action takes place against an isometric 3D background, but there is also an excellent driving section to rival many full-scale driving games.

★ ACE RATING 912

#### VETTE

Mirrorsoft/Spectrum Holobyte • Atari ST TBA • Amiga TBA • PC £29.99  
High speed racing round the streets of San Francisco in one of four Corvettes on offer. The superb 3D colour graphics in the game give a great sense of the wind in your hair as you roar down precariously steep streets desperately trying to avoid pedestrians and other vehicles. Realistic and lots of fun, this game, from the people who brought you *Falcon*, will have you hooked.

★ ACE RATING 926

#### WARHEAD

Activision • Atari ST £24.99dk • Amiga £24.99dk  
Veteran programmer Glynn Williams' latest masterpiece is set in deep space. Earth is under threat from a horde of nasty extra-terrestrial insects. The only hope is the FOE-57, an advanced craft absolutely loaded down with weaponry. Fast solid vector graphics and rapid action make this a winner. Work your way up through the training missions and you'll soon be zapping away quite happily.

★ ACE RATING 920

#### X-OUT

Rainbow Arts • Atari ST £19.99dk • Amiga £19.99dk • Amstrad £9.99cs £14.99dk • Spectrum £9.99cs £14.99dk | C64 £9.99cs £14.99dk  
Possibly the best horizontally scrolling shoot 'em up ever written. There's everything in this game any trigger happy chap could want: well animated sprites, pretty backgrounds, lots of speed, a bagful of weaponry for the taking, loadsabonuses, and plenty of challenge – What more could you want?

★ ACE RATING 939

# TOFWARE INTERNATIONAL

TOFWARE INTERNATIONAL, 24 Tresham Road, Orthon Southgate, Peterborough,  
Bank: Midland Bank, Sort code 40-18-17 51172859 acc. no. 018620472 Fax: 0744-371703

**FREE ORDER PHONE: 0800-898455**

## New New New New New

Newsflash, a monthly diskmagazine with great music, graphics, reviews, programmes, tips and tricks and many more.

Subscription 6 months £ 25.00  
Subscription 12 months £ 45.00

Introduction: Newsflash issue march and april now £ 5.00

### GAMES PACK VOL I

10 disks packed with 30 beautiful games for £ 16.00

### GAMES PACK VOL II

10 disks packed with 11 big and exciting games £ 16.00

### STAR TREK

The game of the movie  
3 disks £ 6.00

### RETURN TO EARTH

game, 1 disk £ 3.00

### SONIX SOUND PACK

10 disks with sound sampling, demo's and great music. 10 disks £ 16.00

### SUPER SEX PACK

10 disks packed with the most beautiful girls, including the best animation £ 16.00

### STARTER PACKAGE

10 disks packed with tips, tricks, CLI help, DEMO's etc. £ 16.00

### SUPER PROGRAMM PACKAGE

15 disks with cadcam, household programmes, anti-virus, games and utilities. A german magazine had tested this package and wrote: "the quality of the programmes is good to very good".  
15 disks £ 22.00

### FRED FISH PACKAGE

We supply all the Fred Fish disks at a price of £ 2.00

We can now offer you the latest 15 Fred Fish disks (246-260) in 1 package with Dmake, labelprint, crossdos, zerg, trektrivia, Fast action, Stevie, Slotcars, Monopoly, Flipper and many more for just £ 22.00

### NEW:

#### SOFTWARE SUBSCRIPTION

Now you can receive the very best new software for your amiga computer every month, at a very low price. Including games, demo's, utilities etc.

5 disks a month £ 9.00 per month  
10 disks a month £ 15.00 per month

### NEW PACKAGE

(18 year and older)

Sexy girls vol 1, 7 disks	£ 10.00
2	£ 10.00
3	£ 10.00
4	£ 10.00

Part 1 + 2 + 3 + 4 28 disks £ 45.00

NEW: PARTY ALL NIGHT/DO IT AGAIN  
PAM £ 5.00

### DISKETTE DUPLICATION

Tofware International is the leading diskette duplicator in Europe. We can offer you the lowest prices, best services, full fulfillment, warehousing, sealing etc.

If you are interested in our services don't hesitate to contact us, we are sure that we can offer you the lowest price available.

5.25" ds/dd	starting at	£ 0.15
5.25" hd/dd	starting at	£ 0.34
3.50" ds/dd	starting at	£ 0.34
3.50" hd/dd	starting at	£ 0.68

All prices are inclusive diskette.

### HOW TO ORDER?

#### Call our freephone 0800-898455

FAX: 0744-371703 (attn. Tofware International Dept.)  
and we will send you the goods by firstclass post. (C.O.D.)

Send cheques or cash to: Tofware International  
24 Tresham Road  
Orthon Southgate  
Peterborough

You also can transfer the total amount to our bankaccount (see above)  
We will ship the goods after arrival.

All prices are inclusive VAT. Please add £ 1.50 to total order.  
We also sent C.O.D. Orders. Please add £ 2.50 to total order.

### NEW PACKAGES:

#### FRED FISH VOL II

Number 261 to 280  
20 disks at £27.50

#### FRED FISH VOL II

Number 281 to 300  
20 disks at £27.50

#### AMIGA TAIFUN PACK I

Numbers 110-120  
10 disks at £16.00

#### AMIGA KICKSTART PACK I

Number 181 to 192  
11 disks at £18.00

#### SEXY GIRLS VOL 5

7 disks £10.00

#### SEXY GIRLS VOL 6

7 disks £10.00

#### SEXY GIRLS VOL 7

7 disks £10.00

**Write for FREE Catalogue.**  
**We stock ALL**  
**Amiga Public Domain**



TEL:  
0782 213993  
(6PM-7.30PM)

TEL:  
0782 712759  
(9AM-5.30PM)

**MAIL ORDER:**  
PC ENGINE SUPPLIES,  
223B WATERLOO ROAD,  
COBRIDGE SOT  
STAFFS  
ST6 2HS

**SHOP:**  
CONSOLE CONCEPTS,  
THE VILLAGE  
NEWCASTLE UNDER LYME  
STAFFS  
ST5 1QB



**NEO GEO Console £420.00**

**GAMES**

MAGIC LOAD	£200.00
BASE BALL	£200.00
VIETNAM 1975	£200.00
GOLF	£200.00

Also suppliers of Sega Megadrive, PC Engines. Specialists in Consoles for over 12 months.

Same day despatch on all access and Visa telephone orders.

We pride ourselves in a fast and reliable service, why not check us out. New Titles arriving all the time

These machines are not officially endorsed by SNK and are imported machines. We supply a full 12 month Guarantee. We undertake this Guarantee as our responsibility and not SNK's or any of it's Licensees

# CONSOLE \* QUEST

Tel : (0903 63786)

Office hours : 10am-1pm 2-9pm Mon-Fri

CONSOLE PILOTS - HERE'S WHERE YOU TAKE TO THE SKIES

We, at Console Quest, would like to share our enjoyment of the very latest consoles with you. Our prices are wonderful, how about a MEGADRIVE or PC ENGINE for £155 for instance.

We supply the games and machines for the GAMEBOY, PC ENGINE, LYNX, SEGA-MEGADRIVE & NEO-GEO. When placing this advertisement, our stocks included the following :-

GAMEBOY	PC ENGINE	MEGADRIVE	IMPORTED NEO GEO
RED ALIMER	POWERDRIFT	THUNDERFORCE 3	BASEBALL
BATMAN	PSYCHO CHASER	DJ BOY	GOLF
SUPER MARIO	BARUMBA	PHANT.STAR 2	MAG'IANLORD
FOOTBALL	NZ STORY	WHIPLASH	VIETNAM -75
BUGS BUNNY	GUNHEAD	GHOSTBUSTERS	More expected
+27 more	+50 more	+23 more	

We supply machines, joypads/sticks, SEGA 8 Bit convertors, 2 player leads - ALL at reasonable prices.

We have the ATARI LYNX with a FREE game and mains lead adaptor. The other games in are : CHIPS CHALLENGE, GATES OF ZENDOCON, BLUE LIGHTNING & ELECTROCOP.

At Console Quest, we also have a game EXCHANGE system for PC ENGINE & MEGADRIVE owners. Please ring for full details.

We are here to help you obtain the maximum pleasure from your machine. At Console Quest, we play them too, you know!

**CONSOLE QUEST, 1 ASHACRE MEWS, OFFINGTON,  
WORTHING,  
W.SUSSEX BN13 2DE**

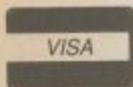
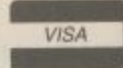

# mph

COMPUTER SPECIALIST

10 Chandlers Court, Eaton, Norwich. NR4 6EY  
Telephone : Norwich (0603) 503382



## DISKS! DISKS! DISKS! DISKS!

10	3.50" DISKS + CASE	£7.75
25	3.50" DISKS	£16.00
50	3.50" DISKS	£30.00
100	3.50" DISKS	£58.00
80	CAPACITY BOXES	£6.50

10	5.25" DISKS + CASE	£4.00
25	5.25" DISKS	£9.50
50	5.25" DISKS	£18.00
100	5.25" DISKS	£34.00
100	CAPACITY BOXES	£6.50

**ALL DISKS COME WITH 2 FOR 1 LIFETIME GUARANTEE : 3.5" MADE BY SONY.**

**CALL FOR PRODUCTS  
NOT LISTED**

**WE CAN OBTAIN  
ANYTHING WITHIN 48  
HOURS**

**ST PD CATALOGUE DISK  
£1.00**

**GAMES RRP MPH  
£19.99 £14.50  
£24.99 £18.50**

**MOST RELEASED GAMES  
IN STOCK. NEW GAMES  
SENT ON DAY OF  
RELEASE**

**ATARI LYNX  
NOW ONLY  
£157.99**

**LYNX GAMES  
RRP MPH  
£29.99 £22.00  
£34.99 £25.50**



# PROGRAMMERS 8 BIT GRAPHIC ARTISTS

We are looking for talented people to join  
our successful team in  
**SWITZERLAND!**

A good knowledge of machine code in either  
Z80, 6502, or 6800 is required.

**WE ARE WAITING FOR YOU!**

If you think you've got what it takes then  
contact Mark Grimmer.  
Oh! Not to forget, we will pay your flight to  
the Swiss mountains...

# LINEL

LINEL,  
Guetlistrasse, 9050 Appenzell,  
Switzerland.

Tel : 01041 71 87 49 19 Fax : 01041 71 87 49 21

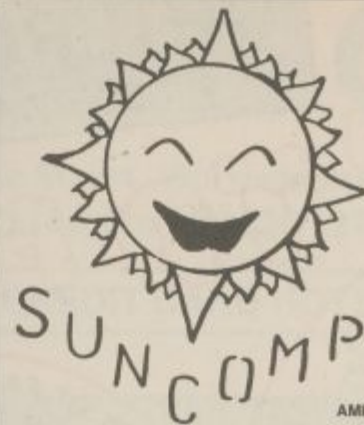

Dept ACE  
39 Edmunds Road,  
Cranwell Village, Sleaford,  
Lincs. NG34 8EL.  
Tel : 0400 62046.

	AMIGA	ST	C64	DISC
American Dreams	18.99	18.99	6.99	10.99
Bomber	22.99	22.99	10.99	14.99
Black Tiger	18.99	14.99	-	-
Cloud Kingdoms	18.99	18.99	6.99	10.99
Cyberball	14.99	14.99	6.99	10.99
Damocles	18.99	18.99	-	-
Defenders of Earth	14.99	14.99	6.99	10.99
Drakkhan	22.99	22.99	-	-
E-Motion	18.99	14.99	7.99	10.99
Escape Planet Robot Man	14.99	14.99	6.99	10.99
F-29 Retaliator	18.99	18.99	-	-
Full Metal Planet	18.99	18.99	-	-
Gravity	18.99	18.99	-	-
Hammerfest	18.99	18.99	-	-
Kick Off 2	14.99	14.99	6.99	10.99
Italy 1990	18.99	18.99	9.99	12.99
Manchester United	18.99	14.99	6.99	10.99
Midwinter	22.99	18.99	-	-
Op Thunderbolt	18.99	14.99	6.99	10.99
P47 Thunderbolt	18.99	18.99	6.99	9.99
Ppmania	18.99	18.99	6.99	10.99
Pro Tennis Tournament	18.99	18.99	-	-
Rainbow Islands	18.99	14.99	6.99	10.99
Shadow Warriors	18.99	14.99	6.99	10.99
Sim City	22.99	22.99	-	14.99
Theme Park Mystery	18.99	18.99	-	-
Treasure Island Dizzy	4.49	4.49	-	2.99
Vendetta	-	-	6.99	10.99
Weird Dreams	18.99	18.99	6.99	10.99
Wipe Out	14.99	14.99	-	-
X-Out	14.99	14.99	6.99	10.99

Other titles and Formats also available. Please write or ring for lists. Remember to state which format you require. If you can't see what you want please ring we're here to help, 7 days a week. Prices include postage and Packing for the UK. For EEC please add £1 per item. Rest of the World please add £2 per item. New Releases sent on day of release. Stock items sent same day. All programmes subject to availability. Please make cheques and postal orders payable to SUNCOMP. We also supply computers, joysticks and other peripherals. Please ring for our very reasonable rates. Suncomp is Mail Order only.

24 HOURS  
DESPATCH. SUB  
TO AVAILABILITY

# MEGA MIX!

ALL ORDERS  
SENT BY 1ST  
CLASS POST

## SPECIAL OFFERS TO ACE MAGAZINE READERS

TITLE	ATARI	AMI	TITLE	ATARI	AMI	TITLE	ATARI	AMI	TITLE	ATARI	AMI
688 Submarine	16.50	16.50	Fifth Gear	13.50	13.50	Rainbow Islands	13.70	16.70	Turricane	13.50	16.50
After the War	13.50	13.50	Fighter Bomber	19.50	19.50	Rally Cross	13.50	13.50	Tusker	16.50	16.50
American Dreams	16.50	16.50	Fighting Soccer	16.50	16.50	Rick Dangerous	16.50	16.50	Untouchables	13.50	16.50
Aquanaut	16.50	16.50	F-Baller of Year 2	13.50	13.50	Risk	13.50	13.50	Wall Street	16.50	16.50
Asterix	16.50	16.50	Gemini Wing	13.70	13.70	Robocoop	13.70	16.70	Warp	13.50	13.50
Bad Company	16.50	16.50	Ghostbusters 2	16.50	16.50	Rock n' Roll	13.50	13.50	Weird Dreams	16.70	16.70
Batman the Movie	13.70	16.70	Ghouls and Ghosts	13.50	16.50	Rocket Ranger	16.50	19.50	Wild Streets	16.50	16.50
Beverly Hills Cop	13.70	16.70	Gravity	16.90	16.90	Run the Gauntlet	13.70	16.70	X-Out	13.70	13.70
Black Tiger	13.70	16.70	Hard Driv'in	13.50	13.50	RVF Honda	16.50	16.50	Xenon 2	16.70	16.70
Bloodwych	16.50	16.50	Heavy Metal	13.70	16.70	Skidz	13.50	13.50			
Bloodwych Data Disk	10.70	10.70	Hot Rod	16.50	16.50	Space Harrier	13.50	13.50			
Cartoon Capers	13.50	13.50	Hound of Shadows	16.50	16.50	Sporting Triangles	13.50	13.50			
Cabal	13.70	16.70	Hyper Action	16.50	16.50	Strider	13.70	16.70			
Chaos Strikes Back	16.50	16.50	Infestation	16.50	16.50	Strip Poker Deluxe	13.50	13.50			
Chase HQ	13.70	16.70	Ironlord	16.50	16.50	Stryx	13.50	13.50			
Conqueror	16.50	16.50	Italy 1990	16.70	16.70	Super Cars (Gremlin)	13.50	13.50			
Crazy Cars 2	13.50	16.50	Ivanhoe	13.70	16.70	Super Hang On	13.50	16.50			
Chronoquest 2	19.70	19.70	Kid Gloves	16.70	16.70	Super League Soccer	16.50	16.50			
Cloud Kingdoms	16.50	16.50	King Arthur	16.50	16.50	Super Wonderboy	13.50	16.50			
Cyberball	13.50	13.50	Klax	13.50	13.50	Switchblade	13.50	13.50			
Day of the Viper	16.50	16.50	Lost Patrol	13.70	16.70	TV Sports B/Ball	18.50	19.50			
Dragon Ninja	13.70	16.70	Magnum 4	19.95	19.95	TV Sports F/Ball	16.50	19.50			
Drakken	19.50	19.50	Manchester United	13.50	16.50	Table Tennis	13.50	13.50			
Dynamite Dux	13.50	16.50	Midwinter	19.70	19.70	Theme Park Mystery	16.50	16.50			
Dyer 07	13.50	13.50	Moonwalker	13.70	16.70	Thrill Time Plat 2	16.70	16.70			
East v West	13.50	13.50	New Zealand Story	13.70	16.70	Time	19.50	19.50			
E-Motion	19.50	19.50	P47 Thunderbolt	16.50	16.50	Times of Law	16.50	16.50			
F16 Combat Pilot	16.50	16.50	Pinball Magic	13.70	16.70	Tom and Jerry	16.50	16.50			
F16 Falcon	16.50	19.50	Powerdrift	16.50	16.50	Tower of Babel	16.50	16.50			
F29 Retaliator	16.70	16.70	Precious Metal	16.70	16.70	Turbo Outrun	13.70	16.70			

### EXTRA SPECIAL BARGAIN OFFERS

TITLE	ATARI	AMI	TITLE	ATARI	AMI
APB	12.50	12.50	Palido	12.50	12.50
Action Service	5.50	5.50	Purple Saturn Day	10.50	11.50
African Raiders	11.50	11.50	Quest for Timebird	9.50	11.50
Archipelagos	11.50	9.50	Red Heat	14.50	15.50
Baal	12.50	12.50	Return of the Jedi	9.50	9.50
Ballistik	13.50	13.50	Road Blasters	12.50	12.50
Battle Valley	10.50	10.50	Roll Out	12.50	10.50
Blastenods	10.50	10.50	Safari Guns	15.50	13.50
Bloodmoney	13.50	13.50	T Gates of Jambala	12.50	12.50
Boulderdash Con Kit	9.50	9.50	Shuffle Pack Cafe	11.50	11.50
Chambers of Shaolin	12.50	12.50	Skidoo	12.50	12.50
Chariots of Warth	10.50	10.50	Slayer	10.50	10.50
Chicago 90's	11.50	11.50	Soldier 2000	12.50	12.50
Conflict in Europe	12.50	12.50	Speedball	10.50	10.50
Cosmic Pirate	9.50	9.50	Spy v Spy	7.50	6.50
Cybermod 2	10.50	10.50	Satr Blaze	10.50	12.50
Dragon Spirit	12.50	12.50	Satr Glider 2	12.50	12.50
Empire Strikes Back	9.50	9.50	Satr Ray	10.50	10.50
Fast Lane	12.50	12.50	Star Wars Trilogy	14.50	14.50
Freedom	12.50	12.50	Steel	10.50	10.50
Full metal Planet	15.50	15.50	Str Crazy (BORD)	10.50	10.50
Genius	9.50	9.50	Super Quintet	10.50	10.50
Galaxy GFprce	12.50	12.50	Targhan	12.50	13.50
Gold Runner 2	10.50	10.50	Tech	10.50	10.50
Kick Off	12.50	12.50	Tin Tin on the Moon	11.50	12.50
Kick Off Extra Time	11.50	11.50	Toobin	12.50	13.50
Laser Squad	13.50	13.50	Trivial Pursuit	10.50	10.50
Mafdel	19.50	19.50	Vindicators	11.50	10.50
Operatin Neptune	10.50	10.50			
Pacland	10.50	10.50			

**3.5" DS/DD BLANK  
DISKS 135 TPI SPECIAL  
OFFER - UP TO 71%  
OFF RRP**  
Qty 10   Qty 20   Qty 50   Qty 100  
£6.50   £11.95   £29.50   £57.95

### JOYSTICKS AND PERIPHERALS

Amiga Second Drive	89.95
Atari Second Drive	89.95
Disk Box 3.5" x 40 Capacity	5.95
Disk Box 3.5" x 80 Capacity	7.95
3.5 Head Cleaner	4.95
Joystick Extension Lead	6.95
Quickshot 2	6.95
Quickshot 3 Turbo	8.95
Quickjoy 5 Superboard	17.95

### MEGA-MIX ORDER FORM

DATE : \_\_\_\_\_  
CUSTOMER NO. (if known) : \_\_\_\_\_

MODEL	£

NAME \_\_\_\_\_  
ADDRESS \_\_\_\_\_  
\_\_\_\_\_

MEGA MIX SOFTWARE, (DEPT ACE), 46  
ASHDEN WALK, TONBRIDGE, KENT  
TN11 3RL

## FREE DISKS

ONLY WHILST STOCKS LAST

WITH EVERY ITEM OF SOFTWARE  
ORDERED YOU WILL RECEIVE ONE  
FREE DISK. THIS OFFER ALSO  
INCLUDES OUR RANGE OF 'EXTRA  
SPECIAL' BARGAINS SO DON'T  
DELAY, ORDER TODAY!

ALL ITEMS INCLUDE FIRST CLASS POSTAGE AND ARE SENT WITHIN 24  
HOURS (SUBJECT TO AVAILABILITY). OVERSEAS ORDERS ADD £5 PER ITEM.  
TO ORDER SEND CHEQUE/POSTAL ORDER PAYABLE TO 'MEGAMIX'

# INTERFACE SOFTWARE

## DOWN TO EARTH PRICES

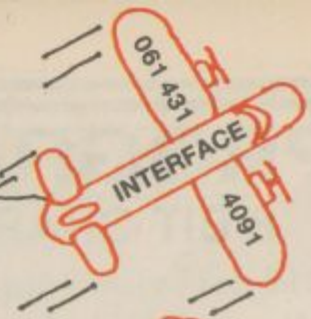

**520 ST POWER PACK**  
ATARI

20 BEST SELLING SOFTWARE TITLES SUCH AS: OTRUN, XENON, PREDATOR AND MUCH MORE. PLUS S.T. BASIC MUSIC MAKER ORGANISER (inc: DATABASE/SPREADSHEET)

inc: 512K RAM INTERNAL POWER SUPPLY BUILT IN IMB DISC DRIVE BUILT IN T.V. MODULATOR MOUSE, JOYSTICK

**£399 inc. VAT**  
+ FREE INTERFACE MEGA PACK 1 OR 2 (WORTH OVER £100)

**FLIGHT OF FANTASY**  
AMIGA

F 29 RETALIATOR RAINBOW ISLAND ESCAPE FROM THE PLANET OF THE ROBOT MONSTERS

inc: 512K RAM IMB DISC DRIVE MOUSE T.V. MODULATOR WORKBENCH SOFTWARE BASIC LANGUAGE DISC

**£399 inc. VAT**  
+ FREE INTERFACE MEGA PACK 1 OR 2 (WORTH OVER £100)

**P.C. STARTER PACK**

(AS SEEN ON T.V.) (inc: 12 MONTHS ON-SITE MAINTENANCE CONTRACT)

PRICES FROM **£599 inc. VAT**  
P.C. 10 SD MONO

ALL PRICES INCLUDE VAT

**BATMAN PACK**  
AMIGA

512K RAM IMB DISC DRIVE MOUSE T.V. MODULATOR WORKBENCH SOFTWARE BASIC LANGUAGE DISC

DELUXE PAINT II BATMAN THE MOVIE NEW ZEALAND STORY INTERCEPTOR

**£399 inc. VAT**  
+ FREE INTERFACE MEGA PACK 1 OR 2 (WORTH OVER £100)

**CLASS OF THE 90'S**  
AMIGA

MIDI INTERFACE & SOFTWARE WORD PROCESSOR D.T.P. PROGRAM SUPERBASE SPREADSHEET AMIGA LOGO

BBC EMULATOR DELUXE PAINT II + FREE INTERFACE MEGA PACK 1 OR 2 (WORTH OVER £100)

**RING FOR DETAILS**

**DISCOVERY PACK**  
ATARI

inc: 512K RAM INTERNAL POWER SUPPLY BUILT IN IMB DISC DRIVE BUILT IN T.V. MODULATOR MOUSE

PLUS FIRST BASIC NEO CHROME ART PACKAGE S.T.O.S. ST. TOUR CARRIER COMMAND, OTRUN SPACE HARRIER BOMB JACK

**£299 inc. VAT**  
+ FREE INTERFACE MEGA PACK 1 OR 2 (WORTH OVER £100)



<p><b>MEGA PACK 1</b></p> <p>CONTAINS:- 10 BLANK DISCS DISC STORAGE BOX DUST COVER MOUSE MAT 5 MYSTERY GAMES</p>		<p><b>MEGA PACK 2</b></p> <p>CONTAINS:- 5 BLANK DISCS DISC STORAGE BOX DUST COVER MOUSE MAT JOYSTICK 5 MYSTERY GAMES</p>		<p><b>BUY 1 GET 1 FREE!</b></p> <p>FOR A LIMITED PERIOD ONLY, WHEN YOU BUY ANY S.T./AMIGA/P.C. GAME, AT THE NORMAL PRICE, WE WILL SUPPLY A MYSTERY GAME ABSOLUTELY FREE!</p>
<p><b>PRINTERS</b></p> <p>STAR LCIO 169 LCIO COL 209 LC24-10 249 CITIZEN-24 299</p> <p>WE ALSO SELL AN EXTENSIVE RANGE OF PERIPHERALS INC.: BOOKS, CABLES, JOYSTICKS - SEND FOR FREE CATALOGUE.</p>	<p><b>MONITORS</b></p> <p>PHILIPS 8833 249 COMMODORE 1084 249 ATARI SM 128</p>	<p><b>DISK DRIVES</b></p> <p>ATARI CUMANA 99 CSA 354 POWER DRIVE 89 AMIGA CUMANA CAX 354 95 ACTION SOFT 89</p>	<p><b>TO ORDER:</b></p> <p>BY PHONE:- CALL OUR SALES TEAM NOW! ON <b>061-431 4091</b></p> <p>WRITE TO:- <b>INTERFACE SOFTWARE</b> P.O. BOX STOCKPORT CHESHIRE. SK4 2AL</p>	
<p><b>DELIVERY</b> - FREE POSTAL DELIVERY COURIER SERVICE AVAILABLE (ADD £5)</p> <p><b>WARRANTY</b> - FULL 12 MONTH WARRANTY ON ALL HARDWARE, (ALL EQUIPMENT TESTED PRIOR TO DESPATCH)</p> <p><b>TECHNICAL SUPPORT</b> - ANY PROBLEMS, PHONE 061-431 4091</p> <p>ALL OFFERS SUBJECT TO AVAILABILITY, INTERFACE RESERVES THE RIGHT TO CHANGE, OR WITHDRAW ANY OFFER WITHOUT PRIOR NOTICE.</p>	<p>CUT OUT AND POST TO ABOVE ADDRESS FOR FREE CATALOGUE</p> <p>NAME _____</p> <p>ADDRESS _____</p> <p>POST CODE _____</p> <p>TEL: _____</p> <p>ACE 8/90</p>			



# ACE DEALS

July is traditionally a 'slow' time of year in the software stores, and many outlets reckon this is a good opportunity to hold a summer sale.

Software Superstore has a host of discounted bargains on titles released earlier this year. We haven't enough space to detail the full range, but, for example, Amiga owners will be able to pick up *Running Man* for £4.99, *IK Plus*, *Super Wonder Boy*, *Millennium 2.2* or *Dynamite Dux* for £6.99, *Blood Money*, *Powerdrift*, or *UMS* for £9.99, or *Shadow of the Beast* (with the T-shirt) for £14.99. Pop down to Software Superstore to see what else is on offer -

and on other formats. Software Circus is fast running out of Colonel's Bequest T-shirts to give away with every Sierra game sold, but if you get to the shop quickly enough, you may be able to take advantage of this promotion. The same goes for the store's IBM music special, with offers on music software for the PC.

In the north of England, the Computer Store chain is offering an extended Amiga bundle at no extra charge. For the normal selling price of £399, you can buy not only the Batpack or Flight of Fantasy pack, but get the Computer Stores pack thrown in as well. This

comprises around £200-worth of related goodies: software, a mouse mat, T-shirts ... Available in selected stores only at the moment, but it could well spread throughout the chain during July, and there will be a similar deal involving the Atari 1040ST pack beginning this month as well.

If you want to win your FIFA football from Computer Stores, hurry, because by the very nature of the competition, it must close the day before the World Cup Final. To enter, simply make your guess as to when the first goal of the final itself will be scored. Don't forget that in the

Leeds Computer Store there's a fortnightly raffle and draw for all customers spending £5 or more in the shop. Prizes vary from month to month, but recently have included a remote-controlled car, videos, software, etc.

Both Software Circus outlets are in London's West End; one in The Plaza, Oxford Street, the other at 282, High Holborn, London WC1.

Software Superstore has outlets at Hanley, Stoke-on-Trent, The Waingate, Sheffield, Little Underbank in Stockport and the centre of St Helen's.

The Computer Store chain is based in Yorkshire,

with shops at Printing Office St, Doncaster; Ivgate, Bradford; Trinity St Arcade, Leeds; Market Place, Huddersfield; Westmoreland St, Wakefield; St Sampson's Square, York; The Woolshops, Halifax; Market St, Barnsley; and also at High Street, Scunthorpe.

All offers and promotions are subject to availability of stock. Although we do our best to ensure our dealer promotion information is accurate at the time of going to press, ACE cannot take any responsibility for changes or cancellations to dealers' plans.

## ATTENTION DEALERS

Don't keep your promotions, competitions, special offers, etc, a secret. Tell us at ACE and we'll tell everybody else.

### WORLDWIDE SOFTWARE 106A CHILWELL RD., BEESTON NOTTINGHAM NG9 1ES

### WORLDWIDE SOFTWARE

### WORLDWIDE SOFTWARE 106A CHILWELL RD., BEESTON NOTTINGHAM NG9 1ES

AMIGA/ST SOFTWARE	A.M.	S.T.
688 Submarine Attack	17.95	
Advanced Ski Simulator	4.99	4.99
A.M.C.	17.95	17.95
Anarchy	17.95	17.95
Arms Head Data Disk	14.95	14.95
Battlehawks 1942	17.95	17.95
Battlemaster	22.95	22.95
Batman the Movie	17.95	14.95
Battle of Britain	22.95	22.95
Betrayer	17.95	17.95
Black Tiger	17.95	14.95
Blade Warrior	17.95	17.95
BMX Simulator	4.99	4.99
Bomber	22.95	22.95
Bomber Mission Disk	14.95	14.95
Bridge Player 2150	21.95	21.95
Castle Master	17.95	17.95
Centrefold Squares	14.95	14.95
Champions of Krynn 1 Meg	22.95	
Chaos Strikes Back Editor		14.95
Chase HQ	17.95	14.95
Chess Champion 2175	22.95	22.95
Chronoquest 2	22.95	22.95
Colorado	17.95	17.95
Colossus Chess X	17.95	17.95
CodeName Iceman	26.95	26.95
Combo Racer	17.95	17.95
Conflict in Europe	17.95	17.95
Conqueror	17.95	17.95
Crack Down	17.95	14.95
Cyberball	17.95	17.95
Damocles	17.95	17.95
Dan dare 3	14.95	14.95
Dark Century	17.95	17.95
Datstorm	14.95	
Defenders of the Earth	14.95	14.95
Deluxe Scrabble	14.95	14.95
Deluxe Strip Poker	14.95	14.95
Double Dragon 2	14.95	14.95
Dragons Breath	22.95	22.95
Dragon Force 1 Meg	22.95	
Dragons of Flame	17.95	17.95
Dungeon Master 1 meg	17.95	17.95
Dungeon Master Editor	7.95	7.95
Dynamic Debugger	17.95	17.95
Dynasty Wars	22.95	22.95
Dyter 7	14.95	14.95
E.Motion	17.95	17.95
Emlyn Hughes Soccer	17.95	17.95
Edison One	17.95	17.95
Elits	17.95	17.95
Escape from Singes Castle	34.95	
Escape Planet Robot Monsters	17.95	17.95
EvertonFC Intelli	14.95	14.95
F16 Combat Pilot	17.95	17.95

AMIGA/ST SOFTWARE	A.M.	S.T.
Flood	17.95	17.95
F16 Falcon Mission Disk	14.95	14.95
F16 Falcon	21.95	17.95
F19 Stealthfighter	22.95	22.95
F29 Retaliator	17.95	17.95
Ferrari Formula One	17.95	17.95
Final Battle	17.95	17.95
Final Hour Battle of Britain	22.95	22.95
Fire Brigade (1 Meg)	21.95	21.95
Fire and Purget 2	17.95	17.95
Flight of Intruder	22.99	22.99
Flight Sim 2 Hawaii		14.99
Scenery	14.99	14.99
Flight Simulator 2	28.95	28.95
Flight Sim 2 Scenery Disk 11	14.95	14.95
Fit Sim 2 Scenery Disk 7	14.95	14.95
Fit Sim 2 Scenery Disk Europe	14.95	14.95

\*\*\*\*\*  
**SUMMERTIME SPECIAL OFFER**  
 \* £1 off all Amiga/ST Titles \*  
 \* Just tell us in which Magazine \*  
 \* you saw our advert then \*  
 \* deduct £1 from our \*  
 \* advertised \*  
 \* price on each title that you \*  
 \* ordered \*  
 \*\*\*\*\*

AMIGA/ST SOFTWARE	A.M.	S.T.
Jumping Jackson	17.95	17.95
Kick Off 2	14.99	14.99
Kick Off 2 + World Cup 90	17.95	17.95
Kid Gloves	17.95	17.95
King Quest Triple Pack	26.95	26.95
Klax	14.95	14.95
Knights of the Crystallion	22.95	
Last Ninja 2	17.95	17.95
Leaderboard Collection	17.95	14.95
Leisure Suit Larry 2	21.95	21.95
Leisure Suit Larry	17.95	17.95
Life and Death	22.95	22.95
Lombard RAC Rally	17.95	17.95
Lost patrol	17.95	14.95
Magnum 4 (Ocean)	22.95	22.95
Magic Maths (4-8 Years)		17.95

AMIGA/ST SOFTWARE	A.M.	S.T.
Rainbow Island	17.95	14.95
Red Lighting	22.95	22.95
Red Storm Rising	17.95	17.95
Resolution 101	17.95	17.95
RoboCop	17.95	14.95
Rotex	17.95	14.95
Rorkes Drift	17.95	17.95
RVF Honda	17.95	17.95
Satan	14.95	14.95
Shadow of the Beast	17.95	
Shadow Warrior	17.95	14.95
Sherman M4	17.95	17.95
Sidewinder 2	4.99	4.99
Silent Service	17.95	17.95
Sim City	21.95	21.95
Sim City Editor	11.95	
Spy Spy Secret Agent	17.95	14.95
Sonic Boom	17.95	17.95
Space Ace	32.95	32.95
Space Quest 2	17.95	17.95
Space Quest 3	26.95	26.95
Star Command	22.95	
Starlight	17.95	17.95
Star Blade	17.95	17.95
Storm Across Europe	17.95	
Subbuteo	14.95	14.95
Supreme Flight Command	22.95	22.95
Stunt Car Racer	17.95	17.95
Test Drive 2 California Challenge	11.99	
Test Drive 2 Musculars	11.99	
Test Drive 2 The Duel	17.95	
Tie Break	17.95	14.95
The Cycles	17.95	17.95
Theme Park	17.95	17.95
Three Bears (5-10 Years)		16.95
Treble Champions	14.95	14.95
Toyotas	14.95	14.95
Treasure Island Dizzy	4.99	4.99
Treasure Trap	17.95	17.95
Treasure Trap	17.95	
Triad Vol 3	22.95	22.95
TV Sports basketball	22.95	22.95
TV Sports Football	21.95	17.95
Ultima 5	22.95	22.95
UMS 2	17.95	17.95
Warhead	17.95	17.95
Wayne Gretzky Hockey	17.95	17.95
Wipe Out	14.95	14.95
World Cup Year 90 Comp	17.95	17.95
World Boxing manager	14.95	14.95
X-Out	14.95	14.95
Xenomorph	17.95	17.95
Xenon 2 Megablast	17.95	17.95

BLANK DISKS - 10 FOR £9.95

**FAST DELIVERY ON ALL STOCK ITEMS BY 1ST CLASS MAIL IN UK  
 SPECIAL OVERSEAS SERVICE BY AIR MAIL WORLDWIDE  
 CREDIT CARD ORDERS ACCEPTED BY PHONE  
 OR MAIL CREDIT CARD ORDER TELEPHONE LINES**

TEL: CREDIT CARD ORDER LINE 0602 225368  
 TEL: CREDIT CARD ORDER LINE 0602 252113 24 HRS

AMIGA/ST SOFTWARE	A.M.	S.T.
Fit Sim 2 Scenery Disk Japan	14.95	14.95
Fimbis Quail	17.95	17.95
Football Manager	4.99	4.99
Football Manager World Cup '90	14.95	14.95
Fun School 2 (8-8)	14.95	14.95
Fun School (over 8)	14.95	14.95
Fun School (under 8)	14.95	14.95
Future Wars	17.95	17.95
Ghosts n' Goblins	14.95	14.95
Gold of Americas	17.95	
Graviti	17.95	17.95
Grand Prix Circuit	17.95	
Greg Normans Ultimate Golf	17.95	17.95
Gunslip	17.95	17.95
Hot Rod	17.95	17.95
Impassable	17.95	17.95
Hammerfist	17.95	
Harball 2	17.95	
Harley Davidson	22.95	22.95
Indy Jones Last Crusade Adv	17.95	17.95
Intellation	17.95	17.95
Italia 1990	4.99	4.99
Italy 1990	17.95	17.95
It came from Desert (1 Meg)	21.95	

\*\*\*\*\*  
**SPECIAL OFFER**  
 \* Amiga 3.5 second drive \*  
 \* plus Shadow of the Beast \*  
 \* Plus RVF Honda plus \*  
 \* Kick Off Plus Battle \*  
 \* Squadron. \*  
 \* The recommended retail price \*  
 \* of these items is £204.00 \*  
 \* OUR PRICE ONLY \*  
 \* £109.00 including delivery \*  
 \*\*\*\*\*

Maniac mansion	17.95	17.95
Manchester United	17.95	17.95
Maths Mania (8-12 Years)		17.95
Microprose Soccer	17.95	17.95
Midwinter	22.95	22.95
Midwinter Resistance	17.95	14.95
Necromon	17.95	17.95
Nitro Boost Challenge	4.99	4.99
Ninja Sprites	17.95	17.95
Ninja Warriors	14.95	14.95
North and South	17.95	17.95
Operation Thunderbolt	17.95	14.95
P47 Thunderbolt	17.95	17.95
Paperboy	14.95	14.95
Pipemania	17.95	17.95
Prattos	17.95	17.95
Player manager	14.95	14.95
Populous Promised lands	7.99	7.99
Populous	17.95	17.95
Projectyle	17.95	17.95
Power Up	14.95	14.95
Powerboat USA	17.95	17.95
Pro Tennis Tour	17.95	17.95
Pyramax	14.95	14.95

Ivanhoe	17.95	14.95
Jack Nicholas Golf	17.95	17.95
Jack Nicholas Int. Course	11.99	11.99
John Lowe Ultimate Darts	14.95	14.95

Please make cheques or postal orders payable to :  
**WORLDWIDE SOFTWARE**

All prices include postage & packing in UK. Credit card orders accepted by phone or mail  
 Fax No : 0602 430477

Advertised prices are for mail and telephone orders. All prices correct at time of going to press.

Outside Europe shipping costs are : £2 per disc for normal airmail, £3 per disc for Express airmail

Europe other than UK shipping costs are : £1.50 per disc for normal airmail, £2.50 per disc for express air mail

# ACE DIARY

## JULY

### Week's releases at a glance

**Image Works:** Bloodwych (C64, £9.99 tape, £14.99 disk); Back to the Future II (Spectrum £10.99 tape, £14.99 disk, ST £24.99).

Game of the film, the launch is timed to coincide with the video release.

**Microprose:** Midwinter (PC £34.99); Strategy meets action in this post-Ice Age chiller. **F19 Stealth Fighter** (ST £24.99); Stylish flight sim from the masters of the genre. **Micro Style:**

**Stunt Car Racer** (CPC £9.99 tape, £14.99 disk); Acclaimed racing game from last Christmas staggers out on the Amstrad. **Broderbund/Domark:**

**Where in the World is Carmen Sandiego?** (PC £34.99 - provisional) Detection, exploration and a spot of geography from the US. **Mindscape:**

**Life and Death** (ST, Amiga £29.99) **Harley Davidson** (ST, Amiga £29.99).

**Origin:** **Ultima V** (Amiga £29.99) Fifth incarnation of the cult series arrives just ahead of its successor's release on PC formats.

**SUNDAY 8** Wimbledon tennis final.

**MONDAY 9** Independence Day, Argentina

**TUESDAY 10** **WEDNESDAY 11**

National Day, Mongolia (anniversary of the People's Revolution). Royal

tournament begins (continues until July 28).

**Thursday 12** Lord Nelson lost his eye on this day in 1794. **Orangeman's Day** (Northern Ireland)

**Friday 13** Anniversary of Live Aid, the concert organised by Bob Geldof, which raised over £50 million for victims of famine in Ethiopia in 1985.

**Saturday 14** Bastille Day, France; Republic Day, Iraq

**Week's releases at a glance** **PSS/Millennium:** **Battlemaster** (Amiga, ST £24.99); Fantasy game with arcade-style control features.

**Micro Style:** **Oriental Games** (Spectrum, CPC £9.99 tape £14.99 disk; ST, Amiga (£24.99); Three martial arts disciplines forming separate games in one package.

**Mindscape:** **World Atlas** (PC CD-ROM £99.99); Not just a collection of maps, but packed with political, economic and statistical data, all cross-referenced by topic and country.

**Guns and Butter** (PC, Apple Mac £34.99) Chris "Balance of Power" Crawford's game of world domination based on economic rather than military prowess. **Origin:** **Bad Blood** (PC £29.99)

**Sunday 15**

St Swithin's Day. The original saying has it that the weather on St Swithin's Day will hold good for the next 40 days, but according to the Guinness Book of Records, after a gloriously sunny St Swithin's Day in 1924, it rained on 30 of the next 40 days.

**Monday 16** Anniversary of the launch of Apollo 11, the spacecraft which carried Neil Armstrong, Buzz Aldrin, and Michael Collins; and landed on the surface of the moon for the first time, in 1969.

**Tuesday 17** Anniversary of Donald Campbell's then world speed record of over 400mph in Bluebird, in 1964.

**Wednesday 18** National Day, Spain.

**Thursday 19** Open Golf Championship begins.

**Friday 20** Independence Day, Colombia.

Anniversary of the first ever record singles chart, published in the US magazine, **Billboard**, in 1940.

**Saturday 21** National Day, Belgium. Lord Nelson lost his right arm on this day in 1797.

Not a lucky month for him. Neil Armstrong became the first man to walk on the moon (and drive a golf ball from it) on this day in 1969.

**Week's releases at a glance** **Mirrorsoft:** **Flight of the Intruder** (PC £34.99) Based on a real North Vietnam campaign, this is the one they call "the next Falcon".

**Microprose:** **F19 Stealth Fighter** (Amiga £24.99). **Activision:** **Bomber Mission Disk** (ST, Amiga, PC £14.99) Accessory disk for the flight sim/blaster **Bomber**.

**Sunday 22** National Day, Poland. Final day of the

Open Golf Championship.

**Monday 23** National Day, Ethiopia.

**Tuesday 24** Muslim New Year 1411 begins.

**Wednesday 25** Independence Day, Liberia.

**Thursday 26** Independence Day, Liberia.

**Friday 27** National Independence Day, Peru.

**Week's releases at a glance** **System 3:** **Tusker** (Amiga, ST £TBA) Last Ninja II (PC £TBA) Take on America, martial arts style. **Domark:**

**Heroes** (ST, Amiga, £29.99, CPC, C64, Spectrum £14.99 tape, £19.99 disk) Compilation featuring **Star Wars**, **Licence to Kill**, **Barbarian II** and **The Running Man**. **Electronic Arts:**

**Deluxe Animate** (PC £to be confirmed) Companion program to the popular **Deluxe Paint** and **Video** series. **Chuck Yeager's Advanced Flight Trainer 2.0** (ST, Amiga £24.99) Held over from last month, this is the latest version of the Yeager-endorsed title, available for the first time on 68000 formats.

**Dragon Wars** (Amiga £24.99) Role-playing game from **Bard's Tale** designers Interplay.

**SSG/Electronic Arts:** **Halls of Montezuma** (Amiga £24.99)

**Sunday 29** **Monday 30**

England beat West Germany 4-2 ("They think it's all over...it is now") to win the World Cup on this day in 1966. Birthdays for Daley Thompson (1958) and The Beano comic (1938).

**Tuesday 31** **AUGUST** **Wednesday 1** National Day, Switzerland.

**Thursday 2**

**Friday 3**

**Saturday 4**

**Week's releases at a glance**

**Sierra/Activision:** **Codename Iceman** (ST, Amiga, £TBA) **Colonel's Request** (ST, Amiga £TBA) **Hero's Quest** (ST £TBA) **Leisure Suit Larry III** (ST £TBA) **Conquest of Camelot** (ST £TBA) A nice big batch of releases for Sierra fans. Unfortunately Activision couldn't confirm any prices before we went to press, but expect them to be around the £25-£30 mark. **Domark:**

**Vindicators** (C64 £9.99) Scrolling tank game based on the Tengen coin-op. **Broderbund/Domark:** **Ancient Art of War** (PC, £34.99 - provisional) Recreate battles from the distant past - against the likes of Genghis Khan, Alexander the Great, etc. **Ancient Art of War at Sea** (PC, £34.99 - provisional) Similar to the above but the roll-call of commanders to pit your wits against includes US pirate John Paul Jones and Lord Nelson. **Where in time is Carmen Sandiego?** (PC, £34.99 - provisional) **Where in the USA is Carmen Sandiego?** (PC, £34.99 - provisional) **Where in Europe is Carmen Sandiego?** (PC, £34.99 - provisional) **Electronic Arts:** **Project Magic Fly** (ST, Amiga £24.99) Negotiate the tunnels and blow up the enemy base in a futuristic setting.

**Sunday 5** **Monday 6** Independence Day, Bolivia. Summer Bank Holiday (Scotland and Eire only).

**Tuesday 7** **Wednesday 8** Birthdays for Dustin Hoffman (1937), Nigel Mansell (1953) and Princess Beatrice of York (1988).

# CONSOLE SUPPLIES

13 Spencer Rd., Ilford, Essex IG3 8PW.

Tel : 081-597-0500 Fax : 081-598-1791

Please make cheques/PO/Visa/Access payable to Console Supplies

VISA

Access

DESCRIPTION	SELLING PR	DESCRIPTION	SELLING PR	DESCRIPTION	SELLING PR
<b>SEGA MEGADRIVE</b>					
Sega Megadrive PAL	175.95	Mickey Mouse	28.90	Chan & Chan	22.95
Sega Megadrive SCART	175.95	Motorcross	28.90	Chase HQ	35.95
Pro - 1 Joystick	34.95	Nemesis	25.90	Dragon Spirit	34.95
Afterburner 2	34.95	Othello	25.90	Enemy Man	25.95
Alex Kidd	22.95	Pachinko Time	25.90	Final Lap Twin	25.95
Curse	34.95	Penguin Land	25.90	Genjin Ruler	34.95
Daimaku Mura	37.95	Penguin Wars Vs	25.90	Gunhead	29.00
Darwin 4081	34.95	Hyper Load Runner	28.90	Heavy Unit	34.95
Forgotten Worlds	34.95	Pinball	25.90	Honey Sky	26.95
Golden Axe	35.95	Pinball Party	25.90	King of the Casino	34.95
Herzog Zwei	34.95	Popeye	26.90	Mr. Heli	34.95
Assault Suit Leynos	35.95	Q Billio	25.90	Ninja Warriors	34.95
Majung Cop Ryu	34.95	Qix	25.90	Overhauled Man	24.95
New Zealand Story	35.95	Quarth	25.90	Power League 2	34.95
Osomatsu	22.95	Rerju	25.90	Pro Basketball	34.95
Phantasy Star 2	55.00	Sa Ga	25.90	R-Type 1	29.00
Phantasy Star 3	60.00	Selection	25.90	R-Type 2	29.00
Power League	32.95	Shanghai	26.90	Rock on	34.95
Psyco Blade	37.95	Solar Striker	26.90	Shanghai	34.95
Rambo 3	34.95	Space Invaders	25.90	Shinobi	34.95
Sokoban	35.95	Super Chinese Land	25.90	Sidearms	29.00
Sorceran	35.95	Super Deformer	25.90	Sokoban	35.95
Space Harrier 2	35.95	Super Mario Land	26.90	Space Invader	34.95
Super Real Basketball	35.95	Tennis	26.90	Splatter House	35.95
Super Hydride	39.95	Tetris	25.90	Stranger Zone	34.95
Super Shinobi	35.95	Trump Boy	25.90	Super Volleyball	34.95
Thunderforce 2	35.95	Vic Tokai	25.90	The Kung Fu	25.95
Vermilion	34.95	World Bowling	25.90	The Legend of Axe	34.95
Zoom	24.95	Bugs Bunny	26.90	Tiger Hell	34.95
DJ Boy	35.95	Spider Man	26.90	Tiger Road	34.95
Final Blow	36.95	<b>PC ENGINE</b>			
<b>NINTENDO GAMEBOY</b>					
Gameboy	85.00	PC Engine PAL	165.00	Volfield	35.95
Gameboy + Tetris	109.00	PC Engine SCART	160.00	Wonderboy	24.95
Alleyway	26.90	PC Engine Super Graf	279.99	World Tennis	32.95
Baseball	26.90	PC Corr Graf	175.00	World Baseball	32.95
Baseball Kids	25.90	CD Rom Unit	315.00	*****	
Batman	26.90	ASC 2 Joystick	38.95	NEO GEO + JOYSTICK	£430.00
Blodia	25.90	Five Player Unit	19.95	VIETNAM 1975	£220.00
Dead Heat Scramble	25.90	Joypad	15.95	MAGICIAN LORD	£220.00
Dracula	26.90	Alien Crush	25.95	BASEBALL STARS	£220.00
Flappy Special	25.90	Armed F	25.95	GOLF	£220.00
Fiboul	25.90	Atomic Robo Kid	34.95	*****	
Go!	25.90	Bally Bally Legend	34.95	<b>MAIL ORDER ONLY</b>	
Heiankyo Alien	25.90	Be Ball	34.95		
Master Karateka	25.90	Bloody Wolf	34.95		
		Blodia	34.95		
		Bullfight	34.95		

# PINK CROSSWORD

## AUGUST '90 PRIZE CROSSWORD

By Mips

### ACROSS CLUES

- 6. Plenty of samples (5)
- 7. Person having a brush with a footballer (7)
- 8. Try to get into heartless sex game from Psygnosis (5)
- 9. Is extra work for Gaul (7)
- 11. Furious game from Elite (7,3)
- 13. What's changed for transfusion of game? (5,5)
- 16. First English men to get let out with Plutonium, say (7)
- 17. Tiara designed by

- computer (5)
- 18. Old soldier's game (7)
- 19. Protect against a drugs problem (5)

### DOWN CLUES

- 1. Love, say, US Gold game (1-6)
- 2. Misbehave when game over (4,2)
- 3. Wood mask I designed for game from Robtek (9)
- 4. Fed up at last with shield (6)
- 5. Aimed to disrupt means of communication (5)
- 10. Unable to sleep, being in so manic a state (9)
- 12. Enzo's Formula One game (7)

- 13. Simulation game for B-29? (6)
- 14. Tour around UN game (6)
- 15. Change in surreal terrain (5)

Send your completed crossword to:

**ACE August '90 Crossword, Priory Court, 30-32 Farringdon Lane, London, EC1R 3AU.**

To arrive not later than 2nd August 1990.

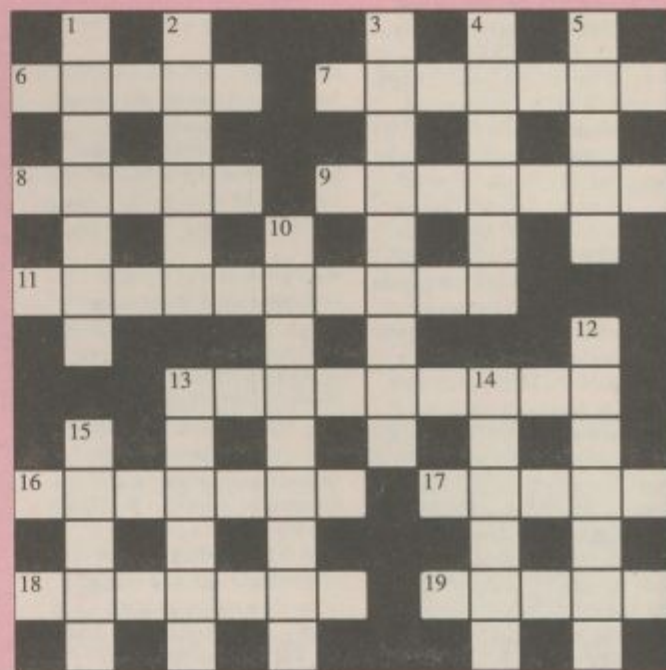

MONTHLY PAYMENT TERMS ARE NOW AVAILABLE THROUGH LOMBARD TRICITY FINANCE ON ALL PURCHASES OVER £150. PLEASE RING FOR DETAILS

### ATARI 520ST DISCOVERY PACK

Atari 520ST with 1mb drive, Mouse, owners manual, first basic, Neochrome, ST Tour, S.T.O.S., Carrier Command, Space Harrier, Bombjack, Outrun.  
**ONLY £279.95**  
**PLUS FREE!!** Our new brilliant software starter pack as follows: Home Accounts, Wordprocessor, Word Count, Mail Merge, Spellchecker, Mono Monitor Emulator, Database, Spreadsheet, Virus Killer, Your 2nd Atari ST manual, Eleven great games, Disk full of useful desk accessories, plus 5 great programs for small children.

### ATARI 520STE NEW!! POWER PACK PACK A

Atari 520STE with 1mb disk drive, Mouse, 20 Game software pack, Business Organizer, First Basic, Basic Guide, First Music, Owners Handbook.  
**ONLY £369.95**

**FREE VCS CONSOLE WITH ALL POWER PACK WHILE STOCKS LAST**  
**PLUS FREE!!** A Superb Starter Pack including wordprocessor, Spreadsheet, Word Count, Spellchecker, Neochrome, Mono Monitor Emulator, Database, Towers of Hanoi, Virus Killer, Sensori, Fruit Machine Stimulation

### PACK B

**CONTAINS ALL ITEMS IN PACK A PLUS!!**  
**FREE VCS CONSOLE WITH ALL POWER PACK WHILE STOCKS LAST**  
 Vinyl Computer Cover, Disk Cleaner, Lockable disk Box - holds 80 disks, Twin joystick extension lead, Ten DS disks, 2nd joystick, Mouse Mat  
**ONLY £399.95**  
**PLUS FREE!!** Our Superb Starter Pack as detailed in Pack A Above. £100

### PACK C

**CONTAINS ALL ITEMS IN PACK A PLUS!!**  
 A Philips CM8833 Colour Monitor with connecting Lead  
**ONLY £609.95**  
**PLUS FREE!!** Our Superb Starter Pack as detailed in Pack A Above

### COMMODORE AMIGA A500 MONSTER PACK

Commodore Amiga A500, Mouse, Workbench 1.3, Workbench Extras, Very first Tutorial Disk, Owners Handbook, Basic Handbook, TV Modulator, Mouse Mat, Word Processor, Paint Package, Music package, Tile Game, 10 Blank Disks, Vinyl Dust Cover, F29 Retaliator, Rainbow Islands, Robot Monsters, Joystick.  
**ONLY £399.95**  
 Including VAT, Delivery and Plug.

### NEW! FLIGHT OF FANTASY PACK

Commodore Amiga A500, Mouse, Workbench 1.3, Workbench Extras, Very First Tutorial Disk, Owners Handbook, Basic handbook, TV Modulator.  
**PLUS!!** Deluxe Paint 2, F29 Retaliator, Rainbow Islands, Robot Monsters  
**ONLY £369.95**  
 Including VAT, Delivery and Plug

### FLIGHT OF FANTASY DOUBLE PACK

Commodore Amiga A500, Mouse, Workbench 1.3, Workbench Extras, Very first Tutorial Disk, Owners Handbook, Basic Handbook, TV Modulator.  
**PLUS!!** Deluxe Paint 2, Rainbow Islands, F29 Retaliator, Robot Monsters, Amegas, Art of Chess, Barbarian, Buggy Boy, Ikari Warriors, Wizball, Mercenary, Thundercats, Terropods, Insanity Fight, 10 Blank Disks, Joystick.  
**ONLY £399.95**  
 Including VAT, Delivery and Plug.

### FLIGHT OF FANTASY MONITOR PACK

Comprises all items as listed in the Flight of Fantasy Pack. **PLUS!!** A Philips CM8833 Colour Stereo Monitor with connecting Lead  
**£609.95**  
 No TV Modulator in this Pack.

### ACCESSORIES PRINTERS

Star LC10 Printer	£169.95
Star LC10 Colour Printer	£209.95
Panasonic KXP1081	£169.95
Panasonic KXP1180	£189.95
Panasonic KXP1124	£279.95
Citizen 120D+	£138.00
Citizen HQP 45	£369.95

All printer prices inc connecting lead to ST PC AMI

### MONITORS

Philips CM8833	£109.95
----------------	---------

### DISK DRIVES

Cumana CSA354 1mb	ST £94.95
Cumana CAX354 1mb	AM £79.95
Mail Centra Amiga 1mb	£69.95
Mail Centra ST 1mb	ST £79.95

### ACCESSORIES

ST Mouse	£24.95
Amiga Mouse	£29.95
Twin Joystick Lead	£5.95
Mouse Mat	£4.95
Amiga TV Modulator	£14.95
3.5" Disk Head Cleaner	£2.95

### VINLY DUST COVERS

Atari 520STFM	£5.95
Amiga A500	£5.95
Atari 1040STFM	£5.95
Atari SM124/SM125	£6.95
Philips CM8833	£6.95
Commodore 1084/S	£6.95
Star LC10	£4.95
Star LC24/10	£4.95
Citizen 1200	£4.95
Panasonic KXP 1081	£4.95
Commodore 64C	£5.95

### JOYSTICKS

Professional	£11.95
Professional +	£13.95
Cheetah 125+	£6.95
Cheetah Mach 1	£8.95
Konix Speeding	£9.95
Konix Speeding Auto Fire	£10.95
Konix Navigator Auto Fire	£11.95
Cruiser Black	£10.95
Cruiser Clear	£10.95
Cruiser Multicoloured	£8.95
Crystal Red	£10.95
Crystal Green	£10.95
Crystal Clear	£12.45
Crystal Red Auto Fire	£12.45
Crystal Green Auto Fire	£12.45
Crystal Clear Auto Fire	£13.95

### SPECIAL OFFER

HIGH QUALITY 3.5" DOUBLE SIDED DISKS WITH LABELS ONLY  
 50 FOR £29.95 100 FOR £49.95

### SPECIAL OFFER

LOCKABLE DISK STORAGE BOX HOLDS 100 3.5" DISKS ONLY  
 £4.95

### SPECIAL OFFER ATARI LYNX

ONLY £159.95  
 INCLUDES: POWER SUPPLY UNIT AND CALIFORNIAN GAMES

### ARCHIMEDES A300

LEARNING CURVE PROMOTION INCLUDES: ARCHIMEDES A3000 ACORN COLOUR MONITOR, MONITOR STAND, RISCOS APPLS 1ST WORD PLUS, GENESIS, DR DOS, PC EMULATOR, MOUSE, MANUAL, TRAINING VIDEO  
 ONLY £899.00  
 PLUS VAT

MAIL-CENTA

17 Campbell St. Belper, Derby DE5 1AP Tel. 0773 826830

All prices include VAT and Delivery in the UK. However for orders under £10.00 please add 50p handling charge. Personal callers welcome at our retail shop but please bring this advert as prices may vary. Closed Wednesdays. All items despatched same day whenever possible. Cheques may require a seven day clearance period. Proprietor Martin Bridges.

LOMBARD

# PREMIER MAIL ORDER

Titles marked \* are not yet available and will be sent on day of release.

Please send cheque/PO/Access/Visa No. and expiry date to :

Dept AC06, Trybridge Ltd., 8 Buckwins Sq., Burnt Mills, Basildon, Essex. SS13 1BJ.

Please state make and model of computer when ordering. P&P inc. UK on orders over £5.00. Less than £5.00 and Europe add £1.00 per item. Elsewhere please add £2.00 per item for Airmail. These offers are available Mail order only.

Tel Orders : 0268 - 590766

## SPECIAL OFFERS

GAME	ST	AMIGA
Adv Rugby Sim	4.99	-
Adv Ski Sim	4.99	4.99
Archeipelagos	9.99	9.99
Art of Chess	7.99	7.99
Ballyhog	7.99	-
Barbarian (pal)	7.99	7.99
Barbarian (Psy)	7.99	7.99
Bards Tale	7.99	7.99
Bionic Commando	7.99	7.99
Bloodwych + Data Disk	19.99	19.99
BMX Sim	4.99	4.99
Boulderdash Con Kit	7.99	7.99
Buggy Boy	7.99	7.99
Captain Blood	4.99	4.99
Championship Wrestling	3.99	-
Conflict	4.99	4.99
Eagles Nest	4.99	4.99
Empire Strikes Back	7.99	-
Fast Lane	-	9.99
Flying Shark	9.99	9.99
Fusion	7.99	7.99
Gladiators	4.99	4.99
Grimblood	4.99	4.99
Hellfire Attack	7.99	7.99
Hollywood Hyjinx	7.99	-
Hollywood Poker	4.99	4.99
Hunter Killer	4.99	4.99
Italia 90	4.99	4.99
Joe Blade 1,2	4.99	4.99
Little Computer People	4.99	-
Live and Let Die	-	7.99
Macadam Bumper	4.99	-
Marble Madness	7.99	7.99
Moonmist	7.99	-
Motorbike Madness	4.99	-
Music Construction Kit	7.99	-
Music X	-	149.99
Nebulous	7.99	-
Nitro Boost	4.99	4.99
Nord and Bert	-	7.99
Outlaw	4.99	4.99
Outrun	7.99	7.99
Pacland	9.99	9.99
Passing Shot	9.99	9.99
Pool	4.99	4.99
Prison	7.99	-
Prohibition	4.99	-
Ramage	-	7.99
Return of the Jedi	7.99	7.99
Rock Star	4.99	4.99
Romantic Encounters	-	7.99
Sidewinder 1 or 2	4.99	4.99
Soldier of Light	7.99	7.99
Speedball	10.99	10.99
Speedboat Assassins	-	4.99
Spellbreaker	7.99	-
Spy v Spy 1,2,3	7.99	7.99
Take em Out	-	9.99
Tetra Quest	7.99	7.99
TNT	4.99	-
Treasure Island Dizzy	4.99	4.99
Veteran	7.99	-
Virus	9.99	-
Warlocks Quest	4.99	4.99
Wishbringer	7.99	-
Zork 1 or 2	7.99	-

GAME	ST	AMIGA	GAME	ST	AMIGA	GAME	ST	AMIGA
1/2 Meg Upgrade	-	59.99	Full Metal Planete	16.99	16.99	Populous	16.99	16.99
Addidas Football	13.99	16.99	Fun School 2 (6-8)	11.99	11.99	Populous Promised Land	7.99	7.99
All dogs go to Heaven	-	16.99	Fun School 2 (over 8)	11.99	11.99	Powerdrome	16.99	16.99
688 Attack Sub	-	16.99	Fun School 2 (under 6)	11.99	11.99	Precious Metal	15.99	15.99
AMOS *	-	34.99	Future Wars	16.99	16.99	Pro Tennis Tour	16.99	16.99
Austerlitz	16.99	16.99	Ghostbusters 2	16.99	16.99	Projectyle	16.99	16.99
Axels Magir Hammer	13.99	13.99	Ghosts and Goblins	13.99	13.99	Rainbow Islands	13.99	16.99
B.A.T. *	16.99	16.99	Ghouls and Ghosts	13.99	16.99	Red Storm Rising	15.99	-
Back to the Future 2 *	16.99	16.99	Gold of the Americas	-	16.99	Resolution 101	16.99	16.99
Balance of Power '90	16.99	16.99	Grand National	-	13.99	Rorkes Drift	16.99	16.99
Bards Tale 1 or 2	5.99	5.99	Grand Prix Circuit	-	16.99	Rick Dangerous	15.99	15.99
Hint book	-	-	Gravity	16.00	16.99	Risk	13.99	13.99
Bards Tale 2	-	16.99	Gunship	14.99	14.99	Robocop	12.99	15.99
Batman caped crusader	12.99	-	Hard Drivin	13.99	13.99	Rotox *	16.99	16.99
Batman the Movie	13.99	16.99	Hard Ball 2	-	16.99	Run the Gauntlet	12.99	15.99
Battle of Britain	19.99	19.99	Heros Quest	-	26.99	RVF Honda	14.99	14.99
Battlechess	16.99	16.99	Heavy Metal	13.99	16.99	S Quest 1,2,3, hint bk	6.99	6.99
Battlemaster *	16.99	16.99	Highway Patrol 2	16.99	16.99	Shadow Warriors *	13.99	16.99
Beach Volley	13.99	16.99	Hillstar	16.99	16.99	Shadow of the Beast	-	22.99
Black Tiger	13.99	16.99	Hounds of Shadow	16.99	16.99	Sherman M4	16.99	16.99
Blade Warrior *	16.99	16.99	Imperium *	16.99	16.99	Shinobi	12.99	12.99
Blood Money	16.99	16.99	Impossamole	13.99	13.99	Shoot em up Con Kit	19.99	19.99
Bloodwych data disk	9.99	9.99	Indy Jones Action	13.99	13.99	Silent Service	14.99	-
Bomber	21.99	21.99	Indy Jones Adventure	16.99	16.99	Silworm IV *	13.99	13.99
Boxing Manager	13.99	13.99	Indy Jones Hint Book	5.99	5.99	Sim City	19.99	19.99
BSS Jane Seymour *	16.99	16.99	Interceptor	-	16.99	Sim City Terrain	-	13.99
Budokan	-	16.99	Interphase	16.99	16.99	Sir Fred	16.99	16.99
Cabal	13.99	16.99	Int Soccer Challenge *	16.99	16.99	Skate or Die *	16.99	16.99
Carrier Command	14.99	14.99	Int 3D Tennis	16.99	16.99	Sleeping Gods Lie	14.99	14.99
Castle Master	16.99	16.99	Iron Lord	16.99	16.99	Sly Spy *	13.99	16.99
Cavadar *	16.99	16.99	Italy 1990 *	16.99	16.99	Space Ace	26.99	26.99
Chaos Strikes Back	16.99	-	It came from t' Desert (1mg)	-	19.99	Space Quest 3	26.99	26.99
Chase HQ	13.99	16.99	It came from the Desert Data *	-	9.99	Speedball 2 *	16.99	16.99
Champions of Krynn (1Meg)	-	21.99	Ivanhoe	13.99	16.99	Spy Who Loved Me *	13.99	13.99
Colorado *	16.99	16.99	Jack Nichlaus Extra courses	9.99	-	Star Trek V *	16.99	16.99
Combo Racer *	13.99	13.99	Jack Nichlaus Golf	16.99	16.99	Star Flight	16.99	16.99
Conflict Europe	16.99	16.99	K Quest 1,2,3,4, hint bk	6.99	6.99	Star Flight Hint Bk	-	5.99
Conqueror	16.99	16.99	Keef the Thief	-	16.99	Star Glider 2	14.99	14.99
Continental Circus	13.99	13.99	Keef the Thief Hint Book	-	5.99	Stos	19.99	-
Crackdown	13.99	16.99	Kennedy Approach	14.99	14.99	Stos Compiler	13.99	-
Crazy cars 2	11.99	14.99	Kick Off	11.99	11.99	Stos Games Galore *	-	16.99
Cyberball	13.99	13.99	Kick Off 2	12.99	12.99	Stos Maestro	16.99	-
Damocles	16.99	16.99	Kick Off extra time	7.99	7.99	Stos Spirites 600	11.99	-
Dan Dare 3	13.99	13.99	Kid Gloves	16.99	16.99	Strider	13.99	16.99
Dark Century	16.99	16.99	Kind Words 2	-	34.99	Stunt Car Racer	15.99	15.99
Degas Elite	17.99	-	Kings Quest 4	21.99	21.99	Subbuteo	12.99	12.99
Deluxe Music Con kit	-	69.99	Kings Quest Triple	26.99	26.99	Supercars	13.99	13.99
Deluxe Paint 3	-	59.99	Klaxx *	13.99	13.99	Swords of Twilight	16.99	16.99
Deluxe Photolab	-	59.99	Knight of the Cry-	-	21.99	Swords of Twilight Hint bk	5.99	5.99
Deluxe Print 2	-	69.99	stallion	-	-	Team Yankee *	16.99	16.99
Deluxe Production	-	89.99	Kult	14.99	14.99	Tennis Cup	16.99	16.99
Deluxe Video 3	-	79.99	Hint Book	-	-	Test Drive 2	-	16.99
Dr Doom	16.99	16.99	Laser Squad	12.99	12.99	T' Drive 2 California Chall	-	9.99
Dragons Lair 2	-	26.99	Leaderboard Birdie	13.99	16.99	Test Drive 2 Muscle Cars	-	9.99
Dragon Ninja	12.99	15.99	Leisure Suit Larry 2	19.99	26.99	Test Drive 2 Supercars	-	9.99
Dragon Spirit	12.99	12.99	Leisure Suit Larry 3	26.99	26.99	The Cycles	-	16.99
Dragons Breath	21.99	21.99	Licence to Kill	12.99	12.99	The Park Mystery	16.99	16.99
Dragons Lair (1Meg)	-	26.99	Life and Death *	19.99	19.99	The Kristal	19.99	9.99
Dragons of Flame	16.99	16.99	Light Force	16.99	16.99	Tie Break	13.99	16.99
Dungeon Master	16.99	16.99	Lombard Rac Rally	14.99	14.99	Time	19.99	19.99
Dungeon Master Editor	7.99	7.99	Loom *	16.99	16.99	Toobin	13.99	13.99
Dungeon Master Hints	9.99	9.99	Lords of the Rising Sun	-	17.99	Total Eclipse	13.99	13.99
Dynamite Debugger *	-	16.99	Lost Patrol	13.99	16.99	Tower of Babel	16.99	16.99
Dynasty Wars *	13.99	16.99	Magnum 4	16.99	16.99	Track Suit Manager	12.99	12.99
Edition One *	16.99	16.99	Manchester United	13.99	16.99	Trained Assassin	-	13.99
Elite	14.99	14.99	Manhunter New York	16.99	21.99	Treble Champions	13.99	13.99
Emlyn Hughes	13.99	13.99	Manhunter NY hint book	6.99	6.99	Triad Vol 3	19.99	19.99
Emlyn Hughes Quiz *	13.99	13.99	Manhunter S'Francisco	21.99	-	Turbo Outrun	13.99	16.99
Escape from Robot	13.99	13.99	Maniac Mansion	16.99	16.99	TV Sports Baseball *	-	19.99
Monsters *	-	-	Microprose Soccer	14.99	14.99	TV Sports Basketball	-	19.99
Escape from Colditz *	16.99	16.99	Monty Python *	13.99	13.99	TV Sports Football	16.99	17.99
F16 Combat Pilot	16.99	16.99	M1 Tank Platoon *	21.99	21.99	Twin World	16.99	16.99
F19 Stealth Fighter	19.99	19.99	Mid Winter	19.99	19.99	UMS	14.99	14.99
F29 Retaliator	16.99	16.99	Mini Office Comms	16.99	-	UMS 2 *	15.99	15.99
Falcon	16.99	19.99	Mini Office Graphics	16.99	-	UMS Scenario 1	8.99	-
Falcon Mission Disk	13.99	13.99	Mini Office Spread	16.99	-	UMS Scenario 2	8.99	-
Falcon Mission Disk 2 *	13.99	13.99	New Zealand Story	13.99	16.99	Unreal *	16.99	16.99
Farey Tale Adventure	-	13.99	Nightbreed *	13.99	16.99	Untouchables	13.99	16.99
Ferrari Formula 1	16.99	16.99	Ninja Spirit	13.99	16.99	Warhead	16.99	16.99
Fighting Soccer	13.99	16.99	Ninja Warriors	13.99	13.99	Waterloo	16.99	16.99
Final Battle *	-	16.99	North and South	16.99	16.99	Wayne Gretzky Hockey	14.99	14.99
Fire and Brimstone *	16.99	16.99	Operation Stealth *	16.99	19.99	Weird Dreams	15.99	15.99
Flight Sim 2	26.99	26.99	Oriental Games *	16.99	16.99	Wild Streets	16.99	16.99
Flight of the Intruder *	16.99	19.99	Operation Thunderbolt	13.99	16.99	Wings *	-	19.99
Ft Disk 7 or 11	13.99	13.99	Operation Wolf	12.99	14.99	Wings of Fury *	13.99	13.99
Ft Disk European	13.99	13.99	Overlander	-	13.99	World Cup Soccer 90	13.99	13.99
Ft Disk Japan	13.99	13.99	Pipemania	13.99	16.99	World Cup Compilations	14.99	14.99
Football Director 2	12.99	12.99	Pirates	15.99	15.99	World Cup Soccer (1Meg)	-	13.99
FtBall Manager2 gift pk	12.99	12.99	Player Manager	12.99	12.99	Xenomorph	16.99	16.99
FtBall of the Year 2	13.99	13.99	Police Quest	16.99	16.99	Xenon 2 Megablast	16.99	16.99
Ford 98 Rally *	16.99	16.99	Police Quest 1,2 hint bk	6.99	6.99	Zak Mckracken	16.99	16.99
Flood *	16.99	16.99	Police Quest 2	16.99	16.99	Zombi	16.99	16.99

SEGA MEGA  
DRIVE

£199.99

Software available  
SAE for list

# JENSTEP

THE FUTURE IN MAIL ORDER BUYING

## MONITOR STANDS:

- 12" MONITOR – £9.95
- 14" MONITOR – £12.95

## PRINTER STANDS:

- UNIVERSAL – £5.95
- UNIVERSAL PRO – £6.95
- UNIVERSAL PRO+ – £8.95
- 80 COLUMN (WIRE) – £7.95
- 132 COLUMN (WIRE) – £8.95

## DATA SWITCH BOXES:

- 2 WAY RS232 – £12.95
- 2 WAY CENTRONICS – £13.95
- 4WAY RS232 – £22.95
- 4 WAY CENTRONICS – £24.95

## PARALLEL PRINTER CABLES:

- 1.5 METRE – £5.95

**FREE** SATELLITE DISH  
AND RECEIVER WITH  
EVERY ORDER OVER  
£100

## MEMOREX

### BULK DISKS:

- 3.5" 2DD – £0.58
- 3.5" 2HD – £1.20
- 5.25" 2DD 48TPI – £0.35
- 5.25" 2DD 96TPI – £0.45
- 5.25" 2HD 1.6MB – £0.60

### BRANDED DISKS:

- 3.5" 2DD – £0.85
- 3.5" 2HD – £1.95
- 5.25" 2DD 48TPI – £0.60
- 5.25" 2DD 96TPI – £0.68
- 5.25" 2HD 1.6MB – £0.85

## SONY

### BRANDED DISKS:

- 3.5" 2DD – £0.86
- 3.5" 2HD – £2.15
- 5.25" 2DD – £0.70
- 5.25" 2HD – £0.89
- 3" PANASONIC BULK DISKS – £1.99



VIDEO  
FRAME  
GRABBER



## ROMBO VIDEO FRAME GRABBER

- VIDI AMIGA – £99.95
- VIDI ST – £86.95
- VIDI PC + – £149.95
- VIDI PCW – £69.95
- VIDI CPC – £60.95
- VIDI ZX – £30.95
- ROMBO – £30.95
- VIDI CHROME – £16.95
- RGB SPLITTER – £59.95

## CONTRIVER MICE:

- C820 ATARI ST – £22.50
- C820 AMIGA + PC111 – £22.50
- C820 IBM PC/XT – £29.95
- ATARI ST TWIN JOYSTICK  
EXTENSION LEADS – £3.50
- CASE & KEYBOARD CLEANING KIT – £3.50
- SCREEN CLEANING KIT – £3.95
- PRINTER CLEANING KIT – £4.95
- LABEL KITS (3.5" & 5.25") – £0.25
- 5.25" WHITE TYVEC ENVELOPE – £0.10



We also stock all new games, art packages, & business programs for a wide range of computers. All software carries at least 30% discount from R.R.P. Call our hotline and 24hr answering service for details.

*All orders up to £20, add £1 delivery.*

*All orders over £20, FREE delivery.*

10/21 MAXWELL OVAL,  
GLASGOW G41 5ST.

(0236 729483)

## JOYSTICKS:

### SURESHOT

- STANDARD – £5.95
- SUPREME – £7.95
- SPECTRUM INTERFACE – £6.95

### ZIPSTICK

- SUPERPRO – £7.95
- SUPERPRO AUTO – £8.95
- COMPETITION PRO 5000 BLACK – £9.95
- COMPETITION PRO 5000 CLEAR – £10.50
- COMPETITION EXTRA – £10.95
- COMPETITION PRO GLO RED – £11.95
- COMPETITION PRO GLO GREEN – £11.95
- COMPETITION PRO AD GAMES CARD – £18.95
- COMPETITION PRO HOME GAMES STARTER PACK – £37.95

## STANDARD DISK BOXES:

- 3.5" 40 – £4.95 80 – £5.95
- 5.25" 50 – £4.95 100 – £5.95

## SPACE MICRO:

- 10 – £4.50

## MOUSE ACCESSORIES

- MOUSE TRAP – £1.95
  - MOUSE MATS – £2.50
- Mats are available in RED, BLUE or GREY. Please state preference when ordering.



# PINK PUZZLE

## AUGUST '90 PUZZLE

Set By Archie Medes

'Oh no! Not another tyrannosaurus!' William threw down the free gift from out of the cornflakes packet and returned gloomily to his breakfast. He only needed one more of the plastic models to complete his set of prehistoric monsters but it seemed that fate was against him as the missing monster defiantly refused to turn up in the packets of cereal bought by his ever-suffering mother. He had tyrannosaurus by the ten, stegosaurus by the score and brontosaurus by the boxload - and the consumption of cornflakes in the household had

increased dramatically as William attempted to munch his way through extra packets. his mother was certain that he had eaten at least twenty since the model offer had started.

Later in the day William sat at his computer and

decided to write himself a short program to try to get to the bottom of the mystery of the missing monster. There were twelve plastic models in the complete set and William wanted to know how many packets, on average, would

be needed to stand a chance of completing his set.

Of course, it is assumed that equal numbers of different models are issued and that they are randomly distributed so that any packet taken from the

supermarket shelf is equally likely to contain any particular model.

How many packets - on average - would you need to buy before obtaining a complete set?

## PINK PUZZLES

Name: .....

Address: .....

ANSWER: .....

Send to: ACE Puzzle August '90, Priory Court, 30-32 Farringdon Lane, London. EC1R 3AU.  
To arrive not later than 2nd August 1990.



## RAPID SERVICE SOFTWARE

SUPPLIERS OF QUALITY SOFTWARE



TITLE	AMIGA	IBMPC	ST	TITLE	AMIGA	IBMPC	ST	PERIPHERALS	
A10 Tank Killer	-	29.99	-	Leisure Ski Larry 111	29.99	33.75	-	Disc Drive Head Cleaners 3"	4.99
Amas	34.99	-	-	LHX Attack Chopper	-	29.99	-	Disc Drive Head Cleaners 3.5"	4.99
Battle of Austerlitz	18.99	18.99	18.99	Maniac Mansion	18.99	18.99	18.99	Disc Drive Head Cleaners 5.25"	4.99
Battle Of Britain (their finest Hour)	22.50	22.50	-	Men Ltd	17.50	17.50	13.99	10x3" CF2 Discs	23.99
Buffedness	18.99	18.99	18.99	Mastersound	34.99	-	34.99	Amiga Power Supply Unit	45.99
Bloodwych Data Disc	10.99	-	10.99	Midwinter	20.99	20.99	20.99	084 Power Supply	18.99
Bloodwych	18.99	18.99	18.99	North and South	17.50	17.50	17.50	Spectrum48K Power Supply	9.99
Bridge Player 2150 Galactica	20.99	20.99	20.99	Ninja Spirit	18.99	-	18.99	C16+4C64/VIC20 Tape Player	24.99
Budokan	18.99	18.99	-	Nuclear War	18.99	18.99	-	Load 11 Tape Player (with 6 free games)	39.99
Buggy Boy	7.50	-	7.50	Operation Thunderbolt	18.99	-	14.99	SPE/MCX/BBC/ELE Tape Player	15.00
Chaos Strikes Back	-	-	18.99	Protes	17.50	-	17.50	Amrad 664/6128 Tape Lead	4.99
Champions of Krynn (1 Meg only)	22.50	22.50	-	Populus	18.99	18.99	18.99	Spectrum 48/128 Loading Leads	3.99
Castle Master	14.99	18.99	14.99	Populus: Promised Lands (Data Disc)	7.50	7.50	7.50	+ 3 Tape Lead	6.99
Cycles	18.99	18.99	-	Pipe Marcs	18.99	18.99	14.99	PC/AMIGA/ST Centronics Printer Lead 2m	9.99
Centrefold Squares	13.99	13.99	13.99	Player Manager	13.99	-	13.99	Amiga to Amiga ST to ST Amiga to ST Lead	29.99
Colossus Chess X	17.50	TBA	17.50	Rainbow Islands	18.99	-	14.99	5 Scart inputs to 1 scart output	10.99
Damocles	17.50	-	17.50	Resolution 101	18.99	22.50	18.99	Amiga Scart Lead	10.99
Daily Double Horse Racing	13.99	13.99	13.99	Robocop	18.99	14.99	14.99	ST Scart Lead	10.99
Deluxe Strip Poker	13.99	13.99	13.99	Sheepman Mk	18.99	18.99	14.99	Amiga A500 RAM Expansion 0.5 meg	59.99
Dragons Breath	-	-	20.99	Shoot em up Construction Kit	20.99	-	20.99	Amiga Modulator	24.99
Drakkon	20.99	20.99	20.99	Sim City	22.50	22.50	22.50	ST Mouse	24.99
Dungeon Master	18.99	22.50	18.99	Starglider 2	7.50	-	7.50	Amiga Mouse	34.99
E - Motion	18.99	-	14.99	Terrain Editor (Sim City data disc)	10.99	10.99	TBA	ST 1 Meg Internal Drive	74.99
Escape from the Planet of the Robot Monsters	14.99	-	14.99	Tenaga Mutant Ninja Turles	22.50	22.50	TBA	ST Second Drive	89.99
F15 Strike Eagle 11	-	24.50	-	Thundercats	7.50	-	7.50	Amiga Second Drive	89.99
F16 Combat Pilot	17.50	17.50	17.50	Ultimate Golf	18.99	18.99	18.99	ST/Amiga Pair of joystick Extenders	6.99
F19 Stealth Fighter	TBA*	27.99	-	Ultima V	-	20.99	20.99	ST/AMIGA/40C+2 Dust Covers	4.99
F29 Resistor	18.99	-	18.99	Ultima VI	-	24.50	-	Mouse mat	3.99
Ferrari Formula 1	13.99	18.99	18.99	Untouchables	18.99	-	18.99	JOYSTICKS	
Fun School 2 (Educational)	18.99	13.99	13.99	Vette	-	22.50	-	Quickshot 11	6.99
Ghostbusters 11	18.99	22.50	18.99	Wind Dreams	17.50	17.50	17.50	Quickshot Turbo	9.99
Gun/Cribbage King	20.99	20.99	-	Wild Swans	17.50	17.50	17.50	Cruiser	9.99
Ghouls and Ghosts	18.99	-	14.99	Xenon 11	18.99	18.99	18.99	Quickshot 25-	8.99
Gravity	18.99	-	18.99	War Head	18.99	-	18.99	(Suitable for Spectrum +2 and +3)	
Gun Boat	-	22.50	-	Zak McKracken	18.99	18.99	18.99	Quickshot mach 1	9.99
Harley Davidson	-	22.50	-	Zombie	18.99	18.99	18.99	Zpstick Super Professional with A/F	12.99
Hammerfest	18.99	-	18.99					Competition Pro 5000	14.99
Hot Rod	18.99	-	18.99					Zip Stick BBC	15.99
Imposserelle	14.99	-	14.99					Spectrum Single Port Interface	9.99
Italy 500	18.99	18.99	-					Spectrum Twin Port Interface	14.99
Italy 1990	18.99	-	18.99					PC Joystick	19.99
Ivanhoe	18.99	-	14.99					PC Game Card	19.99
Jet Fighter	-	29.99	-					Amrad 464/664/6128 Joystick	3.99
Kick Off 2	17.50	-	17.50					Convertible for 2 Joysticks	5.99
								Amrad Autofire Unit	7.99
								40 Capacity x 3.5" Disc Box	9.99
								80 Capacity Disc Box	9.99

For your FREE Catalogue and £1.00 Software Voucher (.)  
: Call 0625 615639.

(.) Valid against orders of £10.00 and over.  
\* Not released at the time of publication. Please phone for details.

This is a small selection of the software we supply.  
Please phone us for a title you want that is not listed.

\* NOW WITH OUT OF HOURS  
ORDERING ON OUR ANSWERPHONE

## LOOK! LOOK! LOOK!

FREE PUBLIC DOMAIN OR DEMO DISC ON ALL  
ST/AMIGA SOFTWARE ORDERS OVER £10.  
ALL ST/AMIGA SOFTWARE CHECKED FOR LOADING.

PLEASE MAKE CHEQUES/PO PAYABLE TO:  
RAPID SERVICE SOFTWARE  
P.O. BOX 57  
MACCLESFIELD  
CHESHIRE  
SK11 6JE  
Tel: 0625 615639

### 3.5" BULK PACKED DISCS

10 + Box - £7.00  
10 - £6.00  
25 - £14.75  
50 - £27.00  
100 - £52.00  
100% CERTIFIED

ALL PRICES INCLUDE VAT AND DELIVERY  
Overseas orders please add £1.00 per item

# MICROSMART MAIL ORDER

Titles marked \* are not yet available and will be sent on day of release. Please state make and model of computer when ordering P&P inc. UK on orders over £5. Less than £5 and Europe add £1 per item. Elsewhere please add £2 per item for airmail. These offers are available Mail order only.

Tel orders : 0908 564369 (24 hrs)

★ FREE GIFT WITH EVERY ORDER!!!! ★ ★ AMIGA 5.12 RAMS + CLOCK £49.00! ★

GAME	ST	AMIGA	GAME	ST	AMIGA	GAME	ST	AMIGA	★ ST SPECIALS ★	
1/2 Meg Upgrade		49.99	Fun School 2 (under 6)	11.99	11.99	Powerdrome	16.99	16.99	Afterburner	6.99
Addidas Football	13.99	16.99	Future Wars	16.99	16.99	Powerdrift	16.99	16.99	Asterix	5.99
688 Attack Sub		16.99	Ghostbusters 2	16.99	16.99	Precious Metal	15.99	15.99	Baal	7.99
AMOS *		34.99	Ghosts and Goblins	13.99	13.99	Pro Tennis Tour	16.99	16.99	Balance of Power	9.99
Austerlitz	16.99	16.99	Ghouls and Ghosts*	13.99	16.99	Rainbow Islands	13.99	16.99	Ballistix	7.99
Axels Magir Hammer	13.99	13.99	Gold of the Americas		16.99	Red Storm Rising	15.99		Blood Money	9.99
B.A.T. *	16.99	16.99	Golden Shoe *	13.99	16.99	Resolution 101 *	16.99	16.99	Brian Cloughs Football	6.99
Back to the Future 2 *	16.99	16.99	Grand National		13.99	Rorkes Drift	16.99	16.99	Chambers of Shaolin	5.99
Balance of Power '90	16.99	16.99	Grand Prix Circuit		16.99	Rick Dangerous	15.99	15.99	Conflict in Europe	7.99
Bards Tale 1 or 2	5.99	5.99	Gravity	16.00	16.99	Risk	13.99	13.99	Cyberoid 2	4.99
Hint book			Gunship	14.99	14.99	Robocop	12.99	15.99	Deja Vu	6.99
Bards Tale 2		16.99	Hard Drivin	13.99	13.99	Rocket Ranger 2	16.99	17.99	Dragon Spirit	7.99
Batman caped crusader	12.99		Heavy Metal	13.99	16.99	Rotox*	16.99	16.99	Eliminator	4.99
Batman the Movie	13.99	16.99	Highway Patrol 2	16.99	16.99	Run the Gauntlet	12.99	15.99	Fernandez Must Die	3.99
Battle of Britain *	16.99	16.99	Hillstar	16.99	16.99	RVF Honda	14.99	14.99	Fish	7.99
Battlechess	16.99	16.99	Hounds of Shadow	16.99	16.99	S Quest 1,2,3, hint bk	6.99	6.99	Football Mgr 2 + Exp Kit	12.99
Battlemaster *	16.99	16.99	Imperium *	16.99	16.99	Shadow Warriors *	13.99	16.99	Galaxy Force	4.99
Beach Volley	13.99	16.99	Impossamole	13.99	13.99	Shadow of the Beast		22.99	Gauntlet 2	7.99
Black Tiger	13.99	16.99	Indy Jones Action	13.99	13.99	Sherman M4	16.99	16.99	Goldrush	9.99
Blade Warrior *	16.99	16.99	Indy Jones Adventure	16.99	16.99	Shinobi	12.99	12.99	Hollywood Poker Pro	7.99
Blood Money	16.99	16.99	Indy Jones Hint Book	5.99	5.99	Shoot em up Con Kit	19.99	19.99	Hunt for Red October	9.99
Bloodwych data disk	9.99	9.99	Interceptor		16.99	Silent Service	14.99		Interphase	9.99
Bomber	21.99	21.99	Interphase	16.99	16.99	Silworm IV *	13.99	13.99	Joan of Arc	7.99
Boxing Manager	13.99	13.99	Int Champ Wrestling		16.99	Sim City	19.99	19.99	Laser Squad	12.99
BSS Jane Seymour *	16.99	16.99	Int Soccer Challenge *	16.99	16.99	Sim City Terrain		13.99	Legend of the Sword	5.99
Budokan		16.99	Iron Lord	16.99	16.99	Sir Fred	16.99	16.99	Manhunter in New York	9.99
Cabal	13.99	16.99	Italy 1990 *	16.99	16.99	Sideshow			Marble Madness	7.99
Carrier Command	14.99	14.99	It came from t' Desert (1mg)	19.99		Silkworm		16.99	Menace	7.99
Castle Master	16.99	16.99	It came from the Desert Data *	9.99		Skate or Die *	16.99	16.99	Micksy Mouse	6.99
Cavadar *	16.99	16.99	Ivanhoe	13.99	16.99	Sleeping Gods Lie	14.99	14.99	Nebulus	4.99
Chaos Strikes Back	16.99		Jack Nichlaus Extra courses	9.99		Sly Spy *	13.99	16.99	Netherworld	4.99
Chase HQ	13.99	16.99	Jack Nichlaus Golf	16.99	16.99	Space Ace	26.99	26.99	Outrun	7.99
Colorado *	16.99	16.99	Jumping Jackson	16.99	16.99	Space Quest 3	26.99	26.99	Pacland	7.99
Combo Racer *	13.99	13.99	K Quest 1,2,3,4, hint bk	6.99	6.99	Space Quest 2	13.99	13.99	Pacmania	8.99
Commando	13.99	13.99	Keef the Thief		16.99	Spy Who Loved Me *	13.99	13.99	Peter Beardsley Soccer	4.99
Conflict Europe	16.99	16.99	Keef the Thief Hint Book		5.99	Star Trek V *	16.99	16.99	President is Missing	6.99
Conqueror	16.99	16.99	Kennedy Approach	14.99	14.99	Star Wars Trilogy	16.99	16.99	Ring of Zahn	9.99
Continental Circus	13.99	13.99	Kick Off	11.99	11.99	Star Flight	16.99	16.99	Rocket Ranger	6.99
Crackdown	13.99	16.99	Kick Off 2 *	12.99	12.99	Star Flight Hint Bk		5.99	R-Type	7.99
Crazy cars 2	11.99	14.99	Kick Off extra time	7.99	7.99	Star Glider 2	14.99	14.99	Seven Gates of Jambala	4.99
Cyberball	13.99	13.99	Kid Gloves	16.99	16.99	Stos	19.99		Shadowgate	7.99
Damocles *	16.99	16.99	Kind Words 2		34.99	Stos Compiler	13.99		Shuffle Pack Cafe	7.99
Dan Dare 3	13.99	13.99	Kings Quest 4	21.99	21.99	Stos Games Galore *	16.99		Skidog	4.99
Dark Century	16.99	16.99	Kings Quest Triple	26.99	26.99	Stos Maestro	16.99		Speedball	7.99
Degas Elite	17.99		Klaxx *	13.99	13.99	Stos Spirites 600	11.99		Starglider 2	6.99
Deluxe Music Con kit		69.99	Knight of the Cry-	21.99	21.99	Strider	13.99	16.99	Sundog Frozen Legacy	3.99
Deluxe Paint 3		59.99	stallion		14.99	Stunt Car Racer	15.99	15.99	Super hang on	7.99
Deluxe Photolab		59.99	Kult	14.99	14.99	Subbuteo	12.99	12.99	Tangl Wood	4.99
Deluxe Print 2		69.99	Hint Book			Supercars	13.99	13.99	Trivial Pursuits	9.99
Deluxe Production		89.99	Laser Squad	12.99	12.99	Swords of Twilight	16.99	16.99	Trivial Pursuits New Beginning	6.99
Deluxe Video 3		79.99	Leaderboard Birdie	13.99	16.99	Swords of Twilight Hint bk	5.99	5.99	TV Sports Football	12.99
Dr Doom	16.99	16.99	Leisure Suit Larry 2	19.99	26.99	Test Drive 2	16.99		Galaxy Force	4.99
Dragons Lair 2		26.99	Leisure Suit Larry 3	26.99	26.99	Tt Drive 2 California Chall	9.99		Brian Cloughs Football	6.99
Dragon Ninja	12.99	15.99	Licence to Kill	12.99	12.99	Test Drive 2 Muscle Cars	9.99		F-18 Interceptor	9.99
Dragon Spirit	12.99	12.99	Life and Death *	19.99	19.99	Test Drive 2 Supercars	9.99		Eliminator	4.99
Dragons Breath	21.99	21.99	Light Force	16.99	16.99	The Jetsons	16.99		Fish	7.99
Dragons Lair (1Meg)		26.99	Lombard Rac Rally	14.99	14.99	The Cycles	16.99		Trivial Pursuits New Beginning	6.99
Dragons of Flame	16.99	16.99	Loom *	16.99	16.99	Theme Park Mystery *	16.99	16.99	Saint and Greavsie	7.99
Drakken	21.99	21.99	Lords of the Rising Sun		17.99	The Kristal	19.99	19.99	Kristal	9.99
Dungeon Master	16.99	16.99	Lost Patrol	13.99	16.99	Time	19.99	19.99	Emmanuelle	7.99
Dungeon Master Editor	7.99	7.99	Magnum 4	16.99	16.99	Toobin	13.99	13.99	Lords of the Rising Sun	11.99
Dungeon Master Hints	9.99	9.99	Manchester United	16.99	16.99	Total Eclipse	13.99	13.99	Batman the Movie	9.99
Dynamite Debugger *		16.99	Manhunter New York	16.99	21.99	Tower of Babel	16.99	16.99	Fernandez Must Die	6.99
Dynasty Wars *	13.99	16.99	Manhunter NY hint book	6.99	6.99	Track Suit Manager	12.99	12.99	Hunt for Red October	9.99
Edition One *	16.99	16.99	Manhunter S'Francisco	21.99		Trained Assassin	13.99		Pacland	6.99
Elite	14.99	14.99	Maniac Mansion	16.99	16.99	Triad Vol 3	19.99	19.99	Pacmania	8.99
Emlyn Hughes *	13.99	13.99	Microprose Soccer	14.99	14.99	Turbo Outrun	13.99	16.99	Starglider 2	7.99
Emlyn Hughes Quiz *	13.99	13.99	M1 Tank Platoon *	21.99	21.99	TV Sports Baseball *		19.99	Conflict in Europe	7.99
Escape from Robot	13.99	13.99	Mid Winter	19.99	19.99	TV Sports Basketball		19.99	Joan of Arc	7.99
Monsters *			Mini Office Comms	16.99		TV Sports Football	16.99	17.99	Trivial Pursuits	9.99
F16 Combat Pilot	16.99	16.99	Mini Office Graphics	16.99		Typhoon Thompson		13.99	Nebulus	4.99
F19 Stealth Fighter	19.99	19.99	Mini Office Spread	16.99		Twin World	16.99	16.99	Cyberoid 2	4.99
F29 Retaliator	16.99	16.99	New Zealand Story	13.99	16.99	UMS	14.99	14.99	Hollywood Poker Pro	7.99
Falcon	16.99	19.99	Nightbreed *	13.99	16.99	UMS 2 *	15.99	15.99	Gold of the Realm (1 Meg)	9.99
Fantavision		29.99	Ninja Spirit	13.99	16.99	UMS Scenario 1	8.99		Baal	7.99
Falcon Mission Disk	13.99	13.99	Ninja Warriors	13.99	13.99	UMS Scenario 2	8.99		Menace	7.99
Farey Tale Adventure	13.99	13.99	North and South	16.99	16.99	Unreal *	16.99	16.99	Ballistix	7.99
Ferrari Formula 1	16.99	16.99	Operation Stealth *	16.99	19.99	Untouchables	13.99	16.99	Shadow of the Beast	16.99
Fighting Soccer	13.99	16.99	Oriental Games *	16.99	16.99	Verminator	15.99		Laser Squad	8.99
Final Battle *	16.99	16.99	Operation Thunderbolt	13.99	16.99	Vortex		13.99	Passing Shot	4.99
Fire and Brimstone *	16.99	16.99	Operation Wolf	12.99	14.99	Warhead	16.99	16.99	3 Stooges	9.99
Flight Sim 2	26.99	26.99	Overlander		13.99	Waterloo	16.99	16.99	Tank Attack	9.99
Flight of the Intruder *	16.99	19.99	P47	15.99	15.99	Wayne Gretzky Hockey	14.99	14.99	Seven Gates of Jambala	4.99
Fit Disk 7 or 11	13.99	13.99	Paperboy	12.99	12.99	Weird Dreams	15.99	15.99	Chambers of Shaolin	7.99
Fit Disk European	13.99	13.99	Pipermania	13.99	16.99	Wild Streets	16.99	16.99	Bloodwych	9.99
Fit Disk Japan	13.99	13.99	Pirates	15.99	15.99	Wings *		19.99	Interphase	9.99
Football Director 2	12.99	12.99	Player Manager	12.99	12.99	Wings of Fury *	13.99	13.99	Gauntlet 11	7.99
Fit'Baller 2 gift pk	12.99	12.99	Police Quest	16.99	16.99	World Cup Soccer 90 *	16.99	16.99	Spy v Spy	4.99
Fit'Baller of the Year 2	13.99	13.99	Police Quest 1,2 hint bk	6.99	6.99	Xenomorph	16.99	16.99	Spy v Spy 2	4.99
Full Metal Planete	16.99	16.99	Police Quest 2	16.99	16.99	Xenon 2 Megablast	16.99	16.99	Spy v Spy 3	4.99
Fun School 2 (6-8)	11.99	11.99	Populous	16.99	16.99	Zak Mckracken	16.99	16.99	Centrefold Squares	7.99
Fun School 2 (over 8)	11.99	11.99	Populous Promised Land	7.99	7.99	Zombi	16.99	16.99	Phobia	4.99

## ★ AMIGA SPECIALS ★

Leaderboard	6.99
Rocket Ranger	9.99
Marble Madness	7.50
Bards Tale 1	7.50
TV Sports Football	12.99
Galaxy Force	4.99
Brian Cloughs Football	6.99
F-18 Interceptor	9.99
Eliminator	4.99
Fish	7.99
Trivial Pursuits New Beginning	6.99
Saint and Greavsie	7.99
Kristal	9.99
Emmanuelle	7.99
Lords of the Rising Sun	11.99
Batman the Movie	9.99
Fernandez Must Die	6.99
Hunt for Red October	9.99
Pacland	6.99
Pacmania	8.99
Starglider 2	7.99
Conflict in Europe	7.99
Joan of Arc	7.99
Trivial Pursuits	9.99
Nebulus	4.99
Cyberoid 2	4.99
Hollywood Poker Pro	7.99
Gold of the Realm (1 Meg)	9.99
Baal	7.99
Menace	7.99
Ballistix	7.99
Shadow of the Beast	16.99
Laser Squad	8.99
Passing Shot	4.99
3 Stooges	9.99
Tank Attack	9.99
Seven Gates of Jambala	4.99
Chambers of Shaolin	7.99
Bloodwych	9.99
Interphase	9.99
Gauntlet 11	7.99
Spy v Spy	4.99
Spy v Spy 2	4.99
Spy v Spy 3	4.99
Centrefold Squares	7.99
Phobia	4.99

# AMIGA AND ATARI ST MEGA DEALS!!!

## FREE HOLIDAY ACCOMADATION

For two people Voucher with every Machine Purchase  
Resorts available are Florida, Majorca, Malta, and Southern Spain

### 520STE POWER PACK

**NEW!!**

**£359.00**

Inc VAT and Next day Delivery

#### POWER PACK includes:

- ★ 520STE 512K Keyboard with Built in 1 Megabyte disk drive and TV Modulator
  - ★ 4096 Colour Palette
  - ★ 8 Channel digital stereo sound
  - ★ 4 Joystick Parts
  - ★ Over £550 worth of games software, including Outrun, Gauntlet 2, R-Type, Space Harrier, Super Hang on and 16 more Top Games.
  - ★ Organiser Business Software including WORDPROCESSOR, SPREADSHEET and DATABASE
  - ★ FIRST BASIC and First music utility Software
  - ★ FREE JOYSTICK AND FREE MOUSE MAT WORTH £4.95
  - ★ All leads, manulas, PLUS MOUSE and free mains plug!
- REMEMBER!** Many ST's do not come with BASIC - ours come with ST BASIC REV D by Metacomco

### 520STE EXPLORER PACK

**NEW!**

**£279.00**

- ★ Explorer Pack includes 520STE 512K Keyboard with built in 1 Megabyte Disk Drive and TV Modulator
- ★ 1 FREE Game, ST Tutorial and METACOMCO Basic worth £25
- ★ All leads, manuals PLUS MOUSE and FREE mains Plug!
- ★ Free mouse mat worth £4.95

### 1040STE BUSINESS PACK

**£479.00**

- ★ Includes the new 1 Megabyte 1040STE keyboard plus over £200 worth of business software including WORD UP wordprocessor software, featuring glossary and mail merge, K Spread 3.0 Spreadsheet and SUPERBASE PERSONAL, database software. Also includes Metcomco BASIC Mouse pad, all leads, manuals, and mouse
- ★ 1040STE Keyboard without software **£439.00**

### MEGA 1 BUSINESS PACK

**£549.00**

#### Features

- ★ Separate Keyboard and Syatem Unit
- ★ Inc all software supplied with 1040STE Business Pack
- ★ Blitter Chip installed for faster graphics
- Inc SM124 Mono Monitor **£628.00**

### ACCESSORIES

- |   |                                 |
|---|---------------------------------|
| Quickshot 11 Turbe Joystick.....£9.95                       | Branded Memorex 3.5" DSDD Disks |
| Competition Pro 5000 Joystick.....£13.95                    | Box of 10.....£13.95            |
| Competition Pro with Autofire.....£14.95                    | Memorex Disk Box                |
| Konix Speedking Joystick.....£11.95                         | For 40 3.5" Disks.....£8.95     |
| Control Centre Atari or Amiga.....£44.95                    |                                 |
| Red, Blue, and Grey Mouse Pads                              | £3.99                           |
| Contriver Amiga and ST Mouse with FREE Holder and Mouse Pad | £19.99                          |

### PRINTERS

- |   |         |
|---|---------|
| Star LC24 1024 Pin incl lead ST/Amiga.....                  | £249.00 |
| Star LC10 including lead for ST/Amiga.....                  | £169.00 |
| Star LC10 colour including interface lead for ST/Amiga..... | £219.00 |
| Citizen 120D including interface lead for ST/Amiga.....     | £139.00 |

### SEIKOSHA 80 COLUMN PRINTERS - AMAZING PRICES

- |   |         |
|---|---------|
| Seikosha 9 pin NLQ including interface lead for ST/Amiga..... | £139.00 |
| Seikosha 24 pin LQ including interface lead for ST/Amiga..... | £239.00 |

### AMIGA A500

#### BAT GAMES PACK

**£399.00**

Inc VAT and next day delivery.

#### BAT Games Pack includes :

- ★ Amiga A500 512K Keyboard with built in 1 Megabyte Disk Drive.
- ★ Free TV modulator worth £24.99 allowing you to use the Amiga with a normal TV
- ★ DELUXE PAINT 11 GRAPHICS PACKAGE
- ★ PHOTON PAINT 11 graphics package with animation worth £70.00
- ★ FREE only just released BATMAN - THE MOVIE games software
- ★ NEW ZEALAND STORY arcade games software
- ★ F16 INTERCEPTOR - amazing 3D flight simulator software
- ★ A further £230 worth of games software, including BUGGY BOY, MERCENARY, BARBARIAN, WIZBALL & six more games
- ★ FREE JOYSTICK, MOUSE MAT AND 10 BLANK D/SKS.
- ★ AMIGA BASIC Amiga EXTRAS 1.3, Workbench 1.3 PLUS the Amiga Step by Step Tutorial.
- ★ All leads manuals PLUS MOUSE and Mainsplug!

### AMIGA 1 MEG

#### BAT GAME PACK

**£529.00**

#### 1 Meg Bat Games Pack includes :

- ★ Fitted 1 Megabyte Memory Expansion + Real Time Clock Card
- ★ Everything listed for the A500 Bat Game Pack
- ★ DRAGONS LAIR 1 MEG MEGAGAME!

### AMIGA A500

#### CLASS OF THE 1990'S BUSINESS + EDUCATIONAL PACK

**£549.00**

#### FEATURES :

- |                                |                            |
|--------------------------------|----------------------------|
| ★ Amiga A500 - TV Modulator    | ★ Maxplan 500 Spreadsheet  |
| ★ Midi Interface - Software    | ★ Amiga Logo BBC Emulator  |
| ★ Kind Words 11 word processor | Deluxe Paint 11            |
| ★ Page Setter DTP              | ★ Mouse Mat 10 Blank Disks |
| ★ Super Base Personal Database | and disk wallet            |

### EXTERNAL DISK DRIVES

- |   |         |
|---|---------|
| Atari SF314 1 Megabyte                            | £139.00 |
| Amiga A1010 1Megabyte                             | £109.00 |
| Cumana 1 Megabyte Atari or Amiga                  | £89.95  |
| NEC 1 Megabyte Atari or Amiga                     | £79.95  |
| Atari Megafile 30 Hard Disk                       | £439.00 |
| NEW! Commodore A590 20 meg Hard Disk              | £369.00 |
| A590 Hard Disk + Memory Upgrade installed (Phone) |         |

### MONITORS

- |   |         |
|---|---------|
| Commodore Amiga A1084 Stereo Monitor inc lead.....                  | £269.00 |
| Atari SC1224 Colour Monitor inc lead.....                           | £259.00 |
| Atari SM124 Mono Monitor including lead.....                        | £119.00 |
| Phillips CM8833 stereo colour monitor inc lead for ST or Amiga..... | £259.00 |

**★ STOP PRESS!! ★**  
**1ST TEN MACHINE ORDERS YOU WILL GET A FREE PORTABLE TELEPHONE VOUCHER!**

CREDIT CARD HOTLINE (24HRS) TELEPHONE 0902 564369. To order either call the credit card Hotline or make a cheque or PO payable to : Microsmart Computers

MICROSMART COMPUTERS, 125 High Street, Stony Stratford, Milton Keynes.MK11 1AT

All prices include VAT and Delivery by Courier

Don't forget the Microsmart Holiday Offer!

VISA



## AMIGA REPAIRS & SPARES

8367 Agnus	34.00	ROM V1.2	32.00
8371 Fat Agnus	49.00	ROMV1.3	32.00
8372 Fat Agnus	62.00	8520 CIA	16.00
S719 Gary	17.00	5721 Buster	16.00
8364 Paula	40.00	68000 MPU	24.00
A1000 Rom Odd	25.00	41256 Ram	4.00
A1000 ROM Even	25.00	LF347	2.50
MSM 6242 Clock	12.00	8362 Denise	29.00

### Many other spares available

Batman Pack	£380.00	A500 Internal Drive	£70.00
Flight of Fantasy Pack	£380.00	A2000 Internal Drive	£70.00
Cumana CAX 354 3.5"	£80.00	A500 PSU	£55.00
External Drive 3.5"	£70.00	Amiga Mouse	£40.00

Also available, leads, books, MIDI Interfaces, Disks, Digitisers, Genlocks, Hard Drives, Joystick, Etc..

All prices include postage and packing

FAST AMIGA 500/1000/2000 repairs (free estimate) - Phone

ACE Repairs,

Dept AF, Outwings Farm, Pelynt, Looe, Cornwall. PL13 2NW.

Tel : 0503-20282

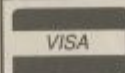

# C.E.S



153 White Hart Lane, Barnes. SW13 0PJ

Tel : 018-876-5501

Sega Mega Drive Pal/Scart (Inc Free Game)	£179.99
Sega 8 Bit Adaptor	£39.99
SNK Neo Geo	£399.99
SNK Games	£210.00
Game Boy Deluxe	£105.00
Game Boy Carrying Case	£15.00
New Games for Mega Drive :	
D.J.Boy	£33.99
Whiplash	£33.99
Thunderforce 3	£35.00

Cheques/PO's to :CES. Add £5 P&P for m/c & £1 for Games.



## ADVENTURE HELPLINE

Do you play computer adventures?  
Have you ever been faced with a seemingly impossible situation?

**WE CAN HELP YOU**

Our adventure rescue team works 7 days a week from noon until midnight and will be pleased to answer your queries. We offer help with any game on any computer, so, if you are tearing your hair out ring this number now:-

**0898 338 933**

Calls charged at 25p per minute, 38p at peak rate.

## ATARI ST - AMIGA OWNERS

We have over 2,000 commercialised ST and Amiga Programs in stock for you to TRY before you BUY. From "Golden Oldies" to the very latest releases. All programs are originals. We have been established for 8 years and have over 3,000 satisfied members from the UK + Europe.

We also offer an efficient computerised service with a fast turn around. For full details send a large SAE (Clearly stating ST or Amiga details) to : MGL (Dept ACE), 48 Read Way, Bishops Cleeve, Cheltenham, Glos. GL52 4EL.

## COMPUTACHAT

Are you a computer games player, programmer, musician or artist? Would you like to make friends with other computer enthusiasts?

Dial Computachat and be connected with up to 10 people at once. Chat about games, music, arts, software, hardware - anything to do with computers! Swap tips, pokes, even software.

Ring Computachat on

**0898 338939**

Experts on hand to help with games problems

**GUIDING LIGHT, PO Box 54  
SOUTHWEST MANCHESTER M15**

Calls charged at 25p per minute off-peak 38p per minute peak time

**MEL CROUCHER**  
**-COMPUTER FUN LINE**

**0898 299399**

New event EVERY WEEK!

3 mins of mind blowing entertainment

**THE HOTTEST GAMES SECRETS**

**MEGATIP GAMESLINE**  
**0898 299388**

Proprietor: B. Everiss, P.O. Box 71, Kineton, Warwick, CV35 0XA.

Calls charged at 25p per minute cheap rate and 38p per minute at all other times. (Ask whoever pays phone bill)

TELEGAMES Europe's Largest Stock of Video Games & Cartridges For — SEGA MEGA DRIVE

NINTENDO GAMEBOY

PC Engine

SNK neo-geo

ATARI 2600 and 7800

LYNX

The leading Video game specialists. Send for lists (state make of game)

**TELEGAMES, WIGSTON, LEICESTER, LE8 1TE. (0533-880445)**

# SOFTSELLERS LTD

MAIL ORDER

6 BOND STREET, IPSWICH, SUFFOLK, IP4 1JE

MAIL ORDER

5A DOG'S HEAD STREET, IPSWICH (RETAIL)

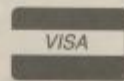

36A OSBORNE STREET, COLCHESTER, ESSEX, (RETAIL)

**MAIL ORDER PURCHASE LINE (0473) 257158/(0473) 210605 FAX (0473) 213457**

	ST	AMIGA		ST	AMIGA		ST	AMIGA
4TH DEMENSION	16.99	16.99	GIANTS (COMPILATION)	19.99	19.99	PREMIER		
688 ATTACK SUB	16.99	16.99	GRAND NATIONAL	19.99	19.99	COLLECTION (COMPILATION)	19.99	19.99
ANTS HEAD (DATA DISK)		12.99	GRAVITY	16.99	16.99	PRO TOURNAMENT TENNIS	16.99	16.99
ANCIENT ART OF WAR	16.99	16.99	GRIM BLOOD	13.99	13.99	PLAYER MANAGER	12.99	12.99
ATOMICS	13.99	13.99	GHOSTBUSTERS II	13.99	16.99	P47	15.99	15.99
ACTION FIGHTER	15.99	15.99	GUNSHIP	15.99	15.99	POWERDRIFT	13.99	16.99
ADDIDAS CHAMP FOOT	16.99	16.99	GAMES SUMMER EDITION	13.99	13.99	PICTIONARY	16.99	16.99
ANARCHY	13.99	13.99	HAMMERLIST	16.99	16.99	PANIC STATION	13.99	13.99
AQUAVENTURA	24.99	24.99	HIGHWAY PATROL	15.99	15.99	QUARTZ	15.99	15.99
BALANCE OF POWER 1990	15.99	15.99	HILLSTAR	16.99	16.99	QUARTER BACK	13.99	13.99
BARBARIAN II (PALACE)	16.99	16.99	HEAVY METAL	13.99	16.99	RAINBOW ISLAND	13.99	16.99
BARBARIAN II (PSYGNOSIS)	16.99	16.99	HERO QUEST	24.99		RESOLUTION 101	16.99	16.99
BANKOK KNIGHTS	13.99	16.99	HALLS OF MONTEZUMA	16.99	16.99	RENEGADE	13.99	16.99
BATTLECHESS	16.99	16.99	HARD DRIVING	13.99	13.99	ROCK AND ROLL	13.99	13.99
BATTLE OF BRITAIN	19.99	19.99	HOUND OF SHADOW	16.99		R V F HONDA	15.99	15.99
BATMAN (THE MOVIE)	13.99	16.99	HOYLES BOOK OF GAMES		24.99	RED STORM RISING	15.99	15.99
BLUE ANGELS	16.99	16.99	INDIANA JONES (LUCAS FILMS)	16.99	16.99	RAINBOW ISLANDS	15.99	15.99
BEACH VOLLEY	13.99	16.99	INDIANA JONES (US GOLD)	13.99	13.99	RISK	13.99	13.99
BATTLEVALLEY		13.99	IVANHOE	13.99	16.99	RALLY CROSS	12.99	12.99
BLACK TIGER	13.99	16.99	INTERNATIONAL 3D TENNIS	16.99	16.99	S E U C K	19.99	19.99
BLADE WARRIOR	15.99	15.99	INFECTION	12.99	12.99	SECRET AGENT FLIES BY	13.99	16.99
BAD COMPANY	12.99	15.99	IRON TRACKER	12.99	12.99	STRYX	13.99	13.99
BATTLE OF AUSTRALITZ	15.99	15.99	INTERNATIONAL CHAMPION			SPACE QUEST III	19.99	19.99
BUDAKHAN		16.99	WRESTLE	16.99	16.99	STEVE DAVIS SNOOKER	12.99	12.99
CHASE HQ	13.99	16.99	IMPERIUM	16.99	16.99	S T O S	19.99	
CHAOS STRIKES BACK	16.99	16.99	INFESTATION	16.99	16.99	STORY SO FAR 1 (COMPILATION)	12.99	12.99
CALIFORNIA GAMES	13.99	13.99	INTERPHASE	15.99	15.99	STORY SO FAR 3 (COMPILATION)	12.99	12.99
CABAL	13.99	16.99	ITALY 1990	16.99	16.99	SUPERLEAGUE MANAGER	16.99	16.99
CRACK OUT	16.99	16.99	INTERNATIONAL ATHLETICS	12.99	12.99	STUNT CAR	15.99	15.99
CONFLICT EUROPE	16.99	16.99	IT CAME FROM THE DESERT		19.99	SHINOBI	13.99	13.99
CARTHAGE	15.99	15.99	JACK BOOT	16.99	16.99	STREET FIGHTING MAN	13.99	13.99
CONQUEROR	16.99	16.99	JACK THE RIPPER	12.99	12.99	SCROLL	12.99	12.99
CORVETTE		19.99	KICK OFF	12.99	12.99	SWORD OF TWILIGHT	16.99	16.99
COMBO RACER	13.99	13.99	KNIGHTS OF KRYSTALLION		19.99	SKIDZ	13.99	13.99
CHUCK YEAGERS A.F.T.	16.99	16.99	KICK OFF II	12.99	12.99	SILPHEED	19.99	19.99
COLARADO	16.99	16.99	KICK OFF EXTRA TIME	9.99	9.99	SLAYER	13.99	13.99
CHICAGO	12.99	12.99	KLAX	13.99	13.99	STORMLORD	13.99	13.99
CYBERBALL	13.99	13.99	KRYSTAL	19.99	19.99	SHADOW OF THE BEAST	24.99	24.99
DEFENDERS OF THE EARTH	12.99	12.99	KEEP THE THEIF		16.99	SHADOW WARRIORS	13.99	16.99
DUNGEON MASTER	16.99	16.99	KILLING GAME SHOW	13.99	13.99	STAR BLAZE	13.99	13.99
DUNGEON MASTER EDITOR	9.99	9.99	LICENCE TO KILL	13.99	13.99	SUPER QUINTET	15.99	15.99
DEMONS TOMB	13.99	13.99	LEISURE SUIT LARRY II	19.99	24.99	SIM CITY	19.99	19.99
DRAGONS BREATH	19.99	19.99	LEISURE SUIT LARRY III	29.99	29.99	SEVEN GATES OF JAMBALA	12.99	15.99
DRAGON FIGHT	16.99	19.99	LEAVING TERAMIS	13.99	16.99	SONIC BOOM	16.99	16.99
DRAKKEN	19.99	19.99	LIGHTFORCE (COMPILATION)	16.99	16.99	STAR FIGHT	16.99	16.99
DOUBLE DRAGON II	13.99	13.99	LOMBARD RAC RALLY	16.99	16.99	SUPER CARS	13.99	13.99
DRAGON WAR		16.99	LORDS OF THE RISING SUN		19.99	SWITCHBLADE	13.99	13.99
DRAGONS OF FLAME	16.99	16.99	LAST NINJA II	16.99	16.99	TRIAD II (COMPILATION)	16.99	16.99
DYNAMIC DEBUGGER	15.99	15.99	LOST PATROL	13.99	16.99	TOYOTTES	13.99	13.99
EAGLE RIDER	16.99	16.99	LIVERPOOL	15.99	15.99	TEST DRIVE II		16.99
ELITE	15.99	15.99	LAST STUNTMAN	12.99	12.99	TENNIS CUP	16.99	16.99
E-MOTION	13.99	16.99	MANIC MANSION	16.99	16.99	TURRICAN	16.99	16.99
EMELYN HUGHES INT SOCCER	16.99	16.99	MAJIC FLY	16.99	16.99	THE KEEP	16.99	16.99
EPOCH	15.99	15.99	MIDWINTER	19.99	19.99	TV SPORTS FOOTBALL	16.99	19.99
EYE OF HERCULES	16.99	16.99	MANCHESTER UTD	13.99	16.99	TV SPORTS BASKETBALL		19.99
ELVIRA MISTRESS OF THE DARK	19.99	19.99	MICROPROSE WORLD			TRIVIAL PURSUIT (FAMILY EDITION)	16.99	16.99
FLASH DRAGON	13.99	13.99	CUP SOCCER 11	15.99	15.99	TRIVIA	12.99	15.99
F29 RETALIATOR	16.99	16.99	MITRO	13.99	13.99	TRACK ATTACK	13.99	16.99
F19 STEALTH FIGHTER	15.99	15.99	MAJIC JOHNSON	12.99	12.99	TURBO OUTRUN	13.99	16.99
F16 COMBAT PILOT	15.99	15.99	MATRIX MARAUDERS	16.99	16.99	TYPHOON THOMPSON		16.99
FALCON	16.99	19.99	NINJA WARRIOR	13.99	13.99	ULTIMATE GOLF	16.99	16.99
FALCON MISSION DISKS	13.99	13.99	NINJA SPIRIT	16.99	16.99	ULTIMATE DARTS	13.99	13.99
FLOOD	16.99	16.99	NEW YORK WARRIOR	13.99	13.99	UNTOUCHABLES	13.99	16.99
FERRARI FORMULA ONE	16.99	16.99	NUCLEAR WAR	16.99	16.99	UNIVERSE III	12.99	12.99
FORGOTTEN WORLDS	13.99	13.99	NORTH AND SOUTH	15.99	15.99	UMS II	15.99	15.99
FUTURE BASKETBALL	16.99	16.99	NEUROMANCER		16.99	ULTIMA V	19.99	19.99
FOOTBALLER OF THE YEAR 2	13.99	13.99	OPERATION THUNDERBOLT	13.99	16.99	VENUS FLY TRAN	13.99	13.99
FAST LANE	12.99	12.99	ORIENTAL	15.99	15.99	WARHEAD	16.99	16.99
FRANKENSTEIN	12.99	12.99	ONSLAUGHT	13.99	13.99	WAR MONGER	16.99	16.99
FUTURE WARS	16.99	16.99	PAPERBOY	12.99	12.99	WATERLOO	15.99	15.99
FIENDISH FREDDY	19.99	19.99	PARADROID	16.99	16.99	WARP	12.99	12.99
FIGHTER BOMBER	19.99	19.99	PROJECTILE	16.99	16.99	WINNERS (COMPILATION)	19.99	19.99
FULL METAL PLANET	15.99	15.99	PINBALL MAJIC	13.99	16.99	XENOMORPH	16.99	16.99
FEDERATION QUEST 1	13.99	13.99	POLICE QUEST II	16.99	16.99	XENON II	16.99	16.99
GEMINI WING	13.99	13.99	POPULOUS	16.99	16.99	X OUT	13.99	13.99
GHOULS AND GHOSTS	13.99	16.99	POPULOUS (DATA DISKS)	9.99	9.99	ZONE WARRIOR	16.99	

**ATARI 520 STFM DISCOVERY PACK**  
BOMB JACK, CARRIER COMMAND, OUTRUN, SPACE HARRIER, STOS, NEOCHROME, FIRST BASIC, ST TOUR, DISCOVER THE ST. £269.95

**ATARI 520 STE POWER PACK**  
23 GREAT TITLES. £349.95

**ATARI 1040 STE**  
PROFESSIONAL PACK £449.95

**ATARI LYNX HAND HELD**  
PORTABLE GAMES MACHINE £179.95

**ATARI SM124**  
MONOCHROME MONITOR £99.95

**ATARI EXTERNAL DRIVE**  
POWER DRIVE 1 MEG D.S £79.95

**AMIGA 500 "FLIGHT OF FANTASY"**  
MODULATOR, F29 RETALIATOR, RAINBOW ISLANDS, DELUXE PAINT II £369.95

**AMIGA 500 BATMAN PACK**  
MODULATOR, BATMAN, NEW ZEALAND STORY, INTERCEPTOR, DELUXE PAINT II. £369.95

**AMIGA 500 + 1084S**  
EITHER PACK ABOVE + COLOUR £599.95

**AMIGA 500 CLASS OF 90'S**  
EDUCATIONAL PACK £529.95

**COMMODORE 1084S**  
COLOUR MONITOR £249.95

**AMIGA EXTERNAL DRIVE**  
POWER DRIVE 1 MEG DS £79.95

**AMIGA MEMORY EXPANSION**  
512K + CLOCK CARD & FREE GAME £99.95

**A590 HARD DRIVE**  
20 MEG HARD DRIVE £369.95

CHEQUES AND POSTAL ORDERS PAYABLE TO SOFTSELLERS. POST & PACKING FREE IN UK. OVERSEAS £1.50 PER ITEM, EXCEPT HARDWARE CHARGED AT COST. SUBJECT TO AVAILABILITY AND PRICE CHANGE WITHOUT NOTICE. NOT ALL TITLES RELEASED AT TIME OF GOING TO PRESS.

TITLE	COMP	PRICE	NAME: .....
			ADDRESS: .....
			.....
			TEL NO: .....
			Have you ordered from us before (yes/no):.....
<b>TOTAL £:</b>			<b>ACE AUGUST</b>

ACE MAGAZINE DOES NOT  
CONDONE PIRACY! ANY ENTRIES  
WILL BE FORWARDED TO THE  
FEDERATION AGAINST SOFTWARE  
THEFT.

# ACE

# READERS' PAGES

## FOR SALE

SPECTRUM 128K+2 Interface, music machine 80 great games inc. Cal games, Star Wars. Sell £120 contact Oliver 01-904-1411.

ST Originals 30 titles £3-15. Hint books for Sierra adventures £3 each. Commodore 16 +s/ware £30 Tel: 0727-37609.

SWAP SEGA Megadrive for Amiga or ST over £280 of games inc. Golden Axe Etc. Tel: Nathan (0742) 683791.

SPECTRUM WITH £400 software Data recorder, 3 Joysticks, Multiface 1 over £100 worth mags. Worth over £500. But will sell for £200.

AMIGA GAMES 26 originals for details send SAE to Andrew Bell, 13 Leatham Cres, Featherstone, Yorks. WF7 5DX.

AMSTRAD CPC 464 Mono monitor AMX Mouse atr £400 software inc. Ghostbusters 2, Chase HQ. Worth £800 sell £350. Tel: After 6.30 0908-378377.

3 ORIGINALS AMIGA GAMES. Hard Drvin', Operation Thunderbolt, and Populous. £12 each or £30 the lot. Call Mark on (07048) 76888.

IBM/AMSTRAD PC1512 SDCM. £50 worth of blank disks + £280 worth of software (including many games and utilities) £510 ono Tel: (0703) 613388

BBC MICRO WITH £100 games, joystick, tape recorder and manuals worth £400 all for £100. Tel: 081-959-5524.

CPC 464 games for sale eg. Batman, All originals. Send SAE to Kim Man Lt, 2 Harewood Way, Macclesfield, Cheshire. SK11 7YF.

AMIGA With 1 Meg upgrade, external Drive, joysticks and a massive collection of software. £560 Tel: 0702-78251.

MEGADRIVE for sale with super Hang on worth £230 sell £160 (only two months old). Tel: 0923-51101 after 6pm (Simon).

ST GAMES for sale, inc Double Dragon 11 and Ninja Warriors. Worth over £300. Sell: £80 Tel: 0252-623141.

CBM 64 Datasette, Music Maker, keyboard, Trackball, Action replay Mk 22, £900 worth software good condition. Sell: £180. Tel: Matthew evenings 081-673-0631.

ATARI 520STFM 1mb boxed, excellent condition, 2 joysticks, Battlehawks 1942, Hostages, Ghostbusters 2, Falcon + Falcon Mission disk, Flight Sim 2, Rocket Ranger, Fast lane, Ninja Warriors and Others. £280. Tel: 07375-54266.

SPECTRUM +3, Quickshot Turbo joystick, leads, disks, disks, tape

recorder, games worth £400 + latest titles only £250 Tel: 081-866-7152.

AMIGA 500 22 games 8 blank disks, box joystick AMP Speakers 1 yr old £350ono. Tel:0325-381510. Available with monitor.

ATARI 520 STFM + 1/2 Meg upgrade, games, serious software, manuals, lots more, worth £800, accept £360ono Tel: 021-308-7420.

C64C HOLLYWOOD pack (excellent condition). 65 + original games (many ACE Rated) Worth £400 + selling for £280 ono Tel: 0381-20285.after 5pm.

HOT NEWSIA590 Hard Drive for sale. Zomb of Pure Power only £300 boxed with manuals. Tel: Lloyd 071-635-9437.

9 AMIGA Games £10-15 each or £100 for the lot. With boxes and instructions excellent condition. Tel: 081-504-9288 between 5pm and 9.30pm.

AMSTRAD CPFC464 £300 Bargain. Colour, Dishad monitor, games, £240 on joystick 14 months old. Worth £600. Tel: weekends 071-708-3326.

COMMODORE 64C Datasette, joysticks, £50 of games: Forgotten Worlds, Robocop. Only used for 6 months. Price £75. Tel: 081-360-3742.

ATARI 520ST + over £500 worth of games + disk drive + joysticks. Only £250. Tel: Brian 647-6532 evenings.

AMSTRAD 464, Colour monitor, over 150 games inc. Dooms Revenge, Robocop, Batman. Worth £900. Sell £225 (0274) 600070. After 6pm.

ATARI 520STFM excellent condition boxed, dust cover, joystick, mouse. £1000 games including 20 originals. bargain at £325. Tel: 081-4281163.

## PENPALS

IBM PC 3 compatible contacts wanted from all over the world to swap solutions, hint books and more! (100% replay) any one is welcome.

HELP WANTED. bought game called "Hacker" for CPC and cannot get Post satellites anyone who can help please write to me.

YO!!Fast Amiga contax needed. Lists, disks, stuff swapped. 101% reply. Ajay, 26 Kenilworth Close, Tipton, West Midlands. DY4 8EQ.

AMIGA Contats wanted. Send lists and disks 100% reply, in 24 hours to Danny 19 Victoria Rd., Pinxtun, Notts. NG16 6LR.

IBM Contacts wanted. Fast reliable 100% reply. Send your lists to Chris Gaua, 25a Atocia Street, Hamrun, Malta

AMIGA Contacts wanted all letters answered send list to Tony, 49

Harmsworth Cresent Hove, East Sussex. BN3 8BU.

ATARI + AMIGA Contacts wanted lots of games. Beginners welcome. 100% reply and fast. PO Box 76, 2995 Zj, Heerjansdan, Holland.

AMIGA Contacts wanted to swap latest. Write to IT.. PO Box 1730 Southport Qld, Australia 4215 100% reply. Write soon.

IBM PC Contacts wanted. Send lists to: W.Wien, Havenland, 103 670899, Wageningen, Holland.

AMIGA Contacts wanted send disks and lists to: Bal, 144 Whalley New Road, Blackburn, Lancashire. BB1 6LB. 100% reply.

YO!! Dudes Amiga contacts wanted, Hot wares only no pirates or lamers. PO Box 40Y Ferry Hills QLD 4055 Australia.

AMIGA Contacts wanted interests are, games PD, Utilities etc.. 100% reply write to P Rance 10 Pine Close, Canvey Island, Essex.

AMIGA Contacts wanted 101% reply. Send Disks and lists to: Dil, 50A Victoria Park, Colwyn Bax, North Wales. LL29 7AJ. Beginners welcome.

1000 + SPECTRUM Pokes and hundreds of C64 pokes. Send SAE with £1.40 to S Freeman (Spec/C64) 31 Durham Crescent, Wedhingham, Lincoln.

AMIGA Contacts definite 100% reply. Write to Rich On Mission grove, London. E17 7DD. No beginners.

## OTHER

SPECTRUM/AMSTRAD Software exchange Club. Originals ONLY. Send SAE for details to SSSC, 178 Forest Road, Kingswood, Bristol. BS15 2EN.

SOFTWARE EXCHANGE Club. Amiga and ST strictly originals only. SAE please for details. RP Day 15 Tunwell Greave, Sheffield. S5 9GB.

## HELPLINE

BLOODWYCH MAPS- £5 Bloodwych Data Maps £5 SAE required state game! 96 St Marys St, Southampton. SO1 1PB.

HOW DO YOU find Odin on Phantasy Star for the Sega Master system Tel: Joe on : 08045 51037 Thanks.

HELP needed for Game Daley Thompson Olympic Challenge for ST help to do all events £0.80 reward if successful. Anyone welcome.

HELP WANTED on Ultima 5, sextant, map of underworld, position of shards

where/how to find British etc..I can also provide help like how to change your sailed game for a higher level where the crown and armet are etc etc. Write to James Kay, PR Hendreiklaan 105 3135 ZC, Vlaakdingen, The Netherlands.

ANNOUNCEMENT! Black Velvet PD LIBRARY Opens 7th July. Send 40p cheque/PO for catalogue to: Black Velvet, 36 Marshall St, Hull. State AMIGA/ST.

ULTIMA 5 HELP urgently needed for (64). Please HELP!! Contact Colin Taylor, Flat 2, 16 Breck Rd., Anfield, Liverpool. L4 2RA.

DOES ANYONE want to swap Target Rnengade and Gouls and Ghosts for the Amstrad Cassette. If so send SAE to Riaz Ladhani, 3 Craven House, Grange Estate, London. N2 8EW.

COMMODORE 64 owner needs help on computer game Robocop. I cannot get past scion 5 (drug factory screen). Has anyone got any tips or cheats. Please help. Write to: G.Turnbull, 11 Moorview, Meltham, Huddersfield, West Yorks.

HELP IS AT HAND to get rid of those nasty Amiga Virus. Send 75p or disk with SAE to: Gavin, 38 Portland Drive, Nuneaton, Warks. CV10 9HY.

ARE YOU AN Amiga usre group who needs disks? if so send SAE to: Gavin, 38 Portland Drive, Nuneaton, Warks. CV10 9HY.

HELP WANTED I desperately need any cheats or pokes for the game, Boulderdash Construction Kit, C64 Version (tape). Will exchange for a C64 reset Switch (genuine), if they work. Please send to Peter 42 Brightfield Rd., Lee Green, London. SE12 8QF.

HELP needed in 68000 and Stos programing. Are you an experienced ST programmer in these languages? Can you code demos and/or games? Do you want to swap routines + info and are willing to help a beginner in 68000 and Stos out? Then write to Dan, 25 Old London Rd., St Albans Herts. Will also swap latest stuff.

HELP please, can't seem to get started in "Causes of Chaos" by CRL in one Player Mode. Just getting off the first six locations please I'm desperate!! K Large, 39 Burnside, Rolleston on Dove, Staffs. DE13 9 DN

BEAST crew urgently need an Amiga Coder to join the group to make demos etc..Please write to: 61 Eltham Gren Rd., Eltham, London SE9 6BJ.

I am totally stuck on Weird Dreams. Please Please PLEASE could anyone help. Send to 10 Kensington Rd., Waih New Zealand, 3991. Might apy extra money.

We are now playing Ultima 6 and intend providing a telephone helpline for fellow fanatics. Anyone with

information problems, hints etc.. Please phone evenings or weekends. 0222-569115 or 0642-781073. Can help with Ultima 1-V and Wizardy 1-V. If writing please enclose large SAE.Ask for Robin.

AMSTRAD CPC464 owner willing to pay for original AMAUROTE on casttte. Write to: P Raffo, 3 Crowland Rd., Sheffield.

POPULOUS I am stuck on world 137 and would welcome tips on strategy. Please write to Billy Chippe, 64 Castletown Rd., London. W14 9HG

IF ANYONE has any pokes, cheats (for Amiga games) note em' down and send them to me (it doesn't matter for which game it is, just send em' up) I'll be very grateful. Send everything to David Vanneste, Pottelberg 158, 8510 Marke, Belgium.

HAVING TROUBLE finding games software, hardware etc. Write: to me J Clarke, Rose Cottage, Rectory Rd., Mellis, Nr Eye, Suffolk.

FREE CPC Mini newsletter just send stamped A5 envelope ASAP to Carl Surry 37 Fairfield Way, Barnet Herts. EN5 2BQ.

HELP WANTED for Indiana Jones and the Last Crusade (action game)!! If you can help me past the first level, please write to: A Atkinson, Edinburgh House School, Fernhill lane, New Milton, Hants.

PROGRAMMERS AMIGA Sprites, music, bitmaps, copper, blitter etc.. etc all explained in a new book "The Amiga Games Programmers Guide" Includes details of game design and game programming! (even how to sell your games). Send SAE for more details to CJ Ditchburn, 12 Eden Court, The Scores, St Andrews, Fife, Scotland.

## NOTICE!

DO YOU WANT  
TO BE IN OUR  
READERS  
PAGES? YES?  
THEN GO TO  
PG.120 AND  
FILL IN THE  
ENTRY FORM  
AND STICK IT  
IN THE  
POST!

Top Quality 2nd Drives for the Amiga  
and Atari ST at low, low prices

**Evesham  
MICROS**

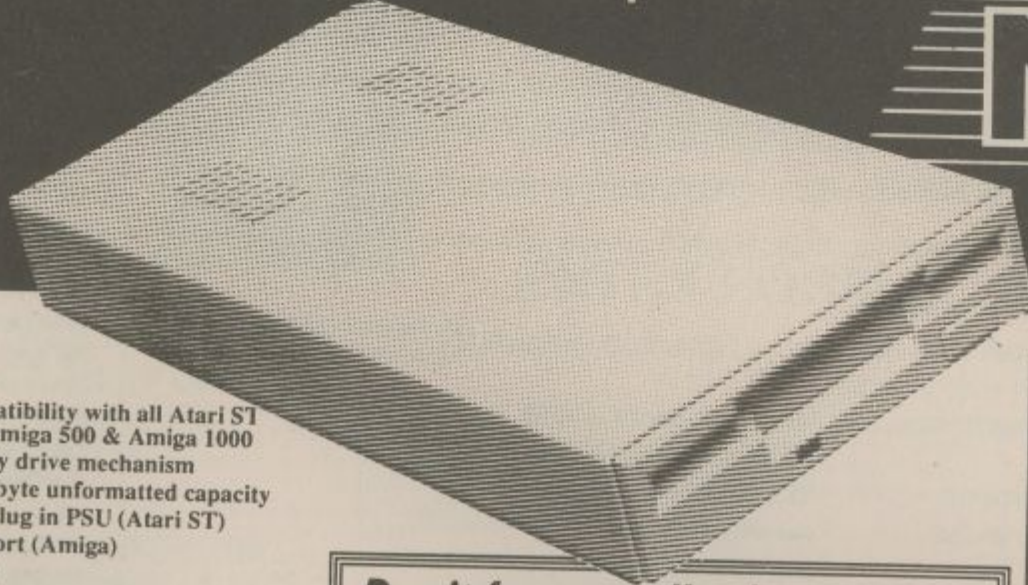

- ✓ Full compatibility with all Atari ST models / Amiga 500 & Amiga 1000
- ✓ Top quality drive mechanism
- ✓ One megabyte unformatted capacity
- ✓ External plug in PSU (Atari ST)
- ✓ Throughport (Amiga)
- ✓ Very quiet
- ✓ Slimline design
- ✓ Colour matched to computer
- ✓ Long cable for location either side of computer
- ✓ Full 12 months guarantee

**Don't forget - all prices shown include VAT and delivery**

**ATARI ST VERSION ONLY**

**£67.95**

**AMIGA VERSION ONLY**

**£62.95**

including VAT and delivery

**ATARI**

All Our Atari ST prices include mouse, user guide, etc. PLUS 5 disks of Public Domain software including paint program, wordprocessor, games, graphics and utilities.

**520 STE POWER PACK**

Includes the latest 520STE computer with 1Mb internal drive, joystick, mouse, user guide, 5 disks of p.d. software, plus a selection of chart-topping software (over £500 RRP) Software includes:

- |               |            |             |             |
|---------------|------------|-------------|-------------|
| R-Type        | Pacmania   | Out Run     | Nebulus     |
| Aherburner    | Starglider | Bombuzal    | Stargoose   |
| Double Dragon | Super Huey | Xenon       | First Music |
| Super Hangon  | Eliminator | Gauntlet II | First Basic |
| Space Harrier | Predator   | Black Lamp  | Organiser   |
| Overlander    | Bombjack   | Staray      |             |

**£339.00**  
Inc. VAT & Delivery

**520 STFM DISCOVERY PACK**

New! High quality, good value package based around the 520STFM computer including 512K RAM, 1Mb Drive and built-in TV modulator. Also supplied is:

- |                   |               |
|-------------------|---------------|
| STOS Game Creator | Outrun        |
| Carrier Command   | Bomb Jack     |
| Space Harrier     | Neochrome     |
| FIRST BASIC       | Atari ST Tour |

plus 'Discovering your Atari ST' Book  
**ALSO AVAILABLE WITH 1MB RAM FITTED, FOR ONLY £339.00**

**£259.00**  
Inc. VAT & Delivery

- 520STE 1Mb Memory Upgrade, very easy to fit, instructions provided ..... £49.00
- 520/1040 STE RAM Upgrade kit to 2Mb, very easy to fit ..... £145.00
- 520/1040 STE RAM Upgrade kit to 4Mb, very easy to fit ..... £290.00
- 1040STE Professional Package - includes Kuma W/Processor, Database, Spreadsheet and Graphics Package, plus 1st Basic, 'STAC' Adventure Creator, 'Hyper Paint' (new STE version) and 'Prince' game all for only ..... £429.00
- 520STFM 1Mb internal drive upgrade kit with full instructions ..... £54.95
- 520 STFM 1Mb memory upgrade kit, requires soldering ..... £59.00
- 520 STFM 1Mb memory upgrade fitted by us ..... £84.00
- Mega ST1 with mono monitor ..... £599.00
- Mega ST2 with mono monitor ..... £849.00
- Mega ST4 with mono monitor ..... £1099.00
- SM124 high resolution monochrome monitor ..... £99.00
- SC1224 colour monitor ..... £269.00
- Megafile 30Mb hard disk ..... £439.00
- 5.25" External 40/80 track drive (360/720K) IBM compatible ..... £99.00
- Vidi-ST 16-tone video frame grabber inc. digitising software ..... £89.00
- Philips CM8833 medium res. stereo colour monitor, with A/V inputs ..... £259.00
- Contriver Hi-Res. Mouse including mouse mat & pocket ..... £22.95
- STF/STFM/STE Joystick accessibility extension adapter ..... £ 4.95
- Lynx Portable Colour Entertainment System, inc. 'California Games' card ..... £159.00

**DOUBLE TAKE!**  
**PHILIPS 15" FST**  
**TV MONITOR**  
(MODEL 2530)

New model from Philips! Superb quality, stylish medium resolution FST colour TV/monitor to suit the ST or Amiga. Features teletext, full infra-red remote control, Euroconnector, Video/Audio input and headphone output connectors, 60 tuner presets, external aerial connector and loop aerial. Supplied with connection cable (please state your computer type when ordering).

**GREAT VALUE!**  
**£269.00**  
includes VAT and computer connection lead

**AMIGA 500 SPECIAL DEALS**

All A500 Packages also include the following:

- |                 |            |                            |
|-----------------|------------|----------------------------|
| Karate Kid II   | Jaws       | Wordwright (w/proc)        |
| Leatherneck     | Defcon 5   | Nigel Mansell's Grand Prix |
| Battle Squadron | High Steel | Night Walk                 |
| Super Huey      | Goldrunner | Better Dead than Alien     |

- A500 512K Batpack including 4 titles and TV modulator ..... £379.00
- A500 512K Flight of Fantasy Pack including 4 titles and TV modulator .... £379.00
- A500 1Mb Batpack (or F.O.F. pack) with our 1Mb RAM upgrade fitted .... £419.00
- A500 Batpack (or F.O.F. pack) with Drive inc. our 2nd 3.5" Drive ..... £439.00
- A500 1Mb Batpack (or F.O.F. pack) with External Drive featuring our 1Mb Memory Upgrade plus 2nd 3.5" External Drive ..... £479.00
- 1.5Mb RAM Board for A500, unpopulated .. £39.95
- 1.5Mb RAM Board with 512K RAM ..... £69.95
- TESSA stereo amplified speaker system ... £34.95
- MIDI interface with In, Out-Thru ports ..... £19.95
- Commodore A590 20Mb Hard Disk ..... £379.00
- 5.25" 40/80 switchable 360/720K drive ..... £99.00
- Omega Projects MIDI Interface inc.cable ... £29.95
- Philips CM8833 colour monitor inc.cable .. £259.00
- Vidi-Amiga including Vidi-Chrome ..... £110.00
- MiniGEN Genlock Adapter ..... £95.00
- Contriver Hi-Res Mouse inc.pocket & mat .. £22.95
- AMOS Game Creator ..... £37.50
- Music-X powerful music package ..... £129.00
- Amiga 500 Dust Cover ..... £4.95



**AMIGA A500**  
**512K**  
**MEMORY**  
**UPGRADE**

**ONLY £43.00** inc.VAT & delivery

**512K RAM/CLOCK EXPANSION FEATURES:**

- ☆ Direct replacement for the A501 expansion
- ☆ Convenient On / Off Memory Switch
- ☆ Auto-recharging battery backed Real-time Clock
- ☆ Compact unit size : Ultra-neat design
- ☆ Uses only 4 low power consumption D-RAMs

RAM expansion without clock, only ... £37.00

**ALL PRICES INCLUDE VAT AND DELIVERY**  
Same day despatch whenever possible. Express Courier delivery £5.00 extra.

**MAIL ORDER DEPARTMENT**

Unit 9 St Richards Rd, Evesham, Worcs WR11 6XJ

Call us now on 0386-765500

8 lines, Open Mon - Sat, 9.00-5.30. Fax: 0386-765354  
Technical support (open Mon - Fri, 9.30-5.30): 0386-40303

Send an Order with Cheque, Postal Order or ACCESS/VISA card details

Government, Education & PLC orders welcome  
All products covered by 12 Months Warranty  
All goods subject to availability, E. & O.E.

**Evesham Micros**

**RETAIL SHOWROOMS**

63 Bridge Street  
Evesham  
Worcs WR11 4SF  
0386-765180  
fax: 0386-49/61  
Open Mon - Sat, 9.00 - 5.30

5 Gilson Road  
Cambridge CB1 2HA  
0223-323898  
fax: 0223-322883  
Open Mon - Sat, 9.30 - 6.00  
Specialist Education Centre

1762 Pershore Road  
Cotteridge  
Birmingham B30 3BH  
021-458 4564  
fax: 021-433 3825  
Open Mon - Sat, 9.00 - 5.30

# THE ACE STOCKMARKET ENTRY FORM

## ROUND NINE

Post this form or a photocopy to ACE Stockmarket, Priory Court, 30-32 Farringdon Lane, EC1R 3AU. Closing date 31st July 1990..

### WHAT YOU HAVE TO DO

Enter your choice for next month's number one entry in each category on the form. You can also choose to go for the Jackpot by trying to predict the top five entries in any one category.

All correct entries will be put into a draw and a random selection made to determine a winner for each of the six categories. There's £25.00 worth of software for your machine waiting for you if you win. If any one gets ALL five entries for their Jackpot Category right, they win a JACKPOT PRIZE of £150 worth of software for their machine.

A photocopy of this form (or a neatly laid out postcard) is acceptable, but please remember to include the round number (9).

NAME: ..... Telephone Number: .....

ADDRESS: .....

My predictions for the TOP TITLE in next month's charts are as follows:

THE TOP GAME FOR THE SPECTRUM WILL BE:

THE TOP GAME FOR THE C64 WILL BE:

THE TOP GAME FOR THE ATARI ST WILL BE:

THE TOP GAME FOR THE AMIGA WILL BE:

THE TOP GAME FOR THE AMSTRAD CPC'S WILL BE:

THE TOP GAME FOR THE PC WILL BE:

THE TOP COMPANY IN THE STOCKMARKET (COMPANY COUNTER) WILL BE:

You can also submit a JACKPOT ENTRY: choose any ONE of the following categories and enter your prediction for the TOP FIVE ENTRIES in next month's charts for that category.

My JACKPOT CATEGORY is (tick one only):

- ST GAMES .....
- AMIGA GAMES .....
- PC GAMES .....
- C64 GAMES .....
- SPECTRUM GAMES .....
- STOCKMARKET (COMPANIES) ...

My five predicted top entries for my Jackpot Category are:

1. ....
2. ....
3. ....
4. ....
5. ....

Rules:

All entries must be received by the closing date for this round of July 31st 1990.

No employees of EMAP, or of any company involved in the production, distribution, or sale of ACE Magazine are eligible for entry.

Only one entry per household. Proof of posting not held as proof of delivery.

The decision of the judges is final and correspondence cannot be entered

ACCESS/VISA  
HOTLINE  
TEL 0273-746467

# BEST BYTE

ALL ORDERS SENT  
BY 1ST CLASS POST  
WITHIN 24 HRS  
(Subject to availability)

LOWEST PRICES

FREE QUALITY 3.5" DS/DD DISK WITH EVERY TITLE ORDERED

LOWEST PRICES!

ATARI ST	RRP	OUR	ATARI ST	RRP	OUR	AMIGA	RRP	OUR	AMIGA	RRP	OUR
Accolade	29.99	19.75	Klax	19.99	13.10	688 Attack Sub	24.99	16.10	Magnum 4	29.99	19.75
Battle Master	24.99	16.10	Magnum 4	29.99	19.75	Abolade Favourites	29.99	19.75	Manhunter 2	29.99	19.35
Blade Warrior	24.99	16.10	Matrix Marauders	19.99	13.10	AMOS The Creator	49.99	34.95	Matrix Marauders	19.99	13.10
Breach 2	24.99	16.10	Midwinter	29.99	19.35	Blade Warrior	24.99	16.10	Midwinter	29.99	19.35
BSS Jane Seymour	24.99	16.10	Ninja Spirit	24.99	16.10	Breach 2	24.99	16.10	Necronom	24.99	16.10
Cartoon Capers	19.99	13.10	Pipe Mania	24.99	16.10	BSS Jane Seymour	24.99	16.10	Ninja Spirit	24.99	16.10
Castle Master	19.99	13.10	Player Manager	19.99	13.10	Cartoon Capers	19.99	13.10	Pirates	24.99	16.10
Combo Racer	24.99	16.10	Power Up	19.99	13.10	Castle Master	24.99	16.10	Player Manager	19.99	13.10
Comquator	24.99	16.10	Projectyle	24.99	16.10	Combo Racer	24.99	16.10	Power Up	19.99	13.10
Damocles	24.99	16.10	Prophecy 1-Viking	24.99	16.10	Defenders of Earth	19.99	13.10	Projectyle	24.99	16.10
Defenders of Earth	19.99	13.10	Resolution 101	24.99	16.10	Dynasty Wars	24.99	16.10	Red Storm	24.99	16.10
Dynasty Wars	19.99	13.10	Rctox	19.99	13.10	Escape Robot Monsters	19.99	13.10	Resolution 101	24.99	16.10
Escape Robot Monsters	19.99	13.10	Shadow Warriors	19.99	13.10	F19 Stealth Fighter	29.99	19.35	Shadow of the Beast	24.99	16.10
F19 Stealth Fighter	29.99	19.35	Sim City	29.99	19.35	F29 Retaliator	24.99	16.10	Shadow Warriors	24.99	16.10
F29 Retaliator	24.99	16.10	Sly Spy	19.99	13.10	Fire and Brimstone	24.99	16.10	Sly Spy	24.99	16.10
Fire and Brimstone	24.99	16.10	Sonix Boom	24.99	16.10	Flimber Quest	24.99	16.10	Sonic Boom	24.99	16.10
Flimber Quest	24.99	16.10	Star Blade	24.99	16.10	Flood	24.99	16.10	Star Blade	24.99	16.10
Flood	24.99	16.10	The Lost Patrol	24.99	16.10	F Man World Cup Ed	19.99	13.10	The Lost Patrol	24.99	16.10
F Man World Cup Ed	19.99	13.10	Theme Park Mystery	24.99	16.10	Ghosts and Goblins	19.99	13.10	Theme Park Mystery	24.99	16.10
Ghosts and Goblins	19.99	13.10	Thunderstrike	24.99	16.10	Gravity	24.99	16.10	Thunderstrike	24.99	16.10
Gravity	24.99	16.10	Tie Break	24.99	16.10	Hammerfest	24.99	16.10	Tie Break	24.99	16.10
Hammerfest	24.99	16.10	Time Soldier	19.99	13.10	Herewith the Clues	24.99	16.10	Time Soldier	24.99	16.10
Hard Drivin	19.99	13.10	Tower of Babel	24.99	16.10	Imperium	24.99	16.10	Treasure Trap	24.99	16.10
Herewith the Clues	24.99	16.10	Treasure Trap	24.99	16.10	Infestation	24.99	16.10	Turcan	24.99	16.10
Imperium	24.99	16.10	Ultimate Golf	24.99	16.10	Inter 3D Tennis	24.99	16.10	Ultimate Golf	24.99	16.10
Infestation	24.99	16.10	Venus the Flytrap	19.99	13.10	Italia 90 (0.5Meg)	19.99	13.10	Ultima 5	29.99	19.35
Internal 3D Tennis	24.99	16.10	Warhead	24.99	16.10	Italia 90 (1 Meg)	19.99	13.10	Venus the Flytrap	19.99	13.10
Italy 1990	24.99	16.10	World Boxing Manager	19.99	13.10	Italy 1990	24.99	16.10	Warhead	24.99	16.10
Ivanhoe	19.99	13.10	World Cup Compilation	24.99	16.50	Ivanhoe	24.99	16.10	World Boxing Manager	19.99	13.10
Kick Off 2	19.99	13.10	World Cup Italia 90	19.99	13.10	Kick Off 2	19.99	13.10	World Cup Compilation	24.99	16.50

3.5" DS/DD  
DISKS

QUALITY  
UNBRANDED

\*  
10      £4.95  
50      £23.45  
100     £44.95

\*  
Boxed in 10's with  
labels. Guaranteed

ESTABLISHED 1986

ACE AUGUST

FREE DISKS!

BEST BYTE ORDER FORM

FREE DISKS!

ST/AMIGA	ITEM	AMOUNT

CUST No (if known) ..... Payment : Cheque/PO/Access/Visa  
NAME .....

ADDRESS .....

.....

Card No .....

To order send this form with payment payable to 'Best Byte' or phone our Credit Card Hotline 0273 746467  
Mail Order only. Prices include 1st Class Postage, packing and VAT. Overseas orders add £5 per item  
BEST BYTE (Dept ACE 35) 48 Nevill Av, Hove, E.Sussex, BN3 7NA





# HOW TO PLACE YOUR ENTRY

All you have to do is send off the form below, together with your payment;  
**Entries to the Pink Pages cost just £4.00 each. (Except for helpline which is free).**

- The maximum is 20 words except for Helpline. (Helpline entries can be extended to 100 words max – use another sheet of paper if necessary).
- The service is NOT open to trade advertisers.
- We will print your advertisement in the first available issue.
- Entries which could be interpreted as encouraging software piracy will not be accepted.

## ENTRY FORM

POST TO: ACE Readers Page,  
 Emap B+CP, Priory Court,  
 30-32 Farringdon Lane,  
 London EC1R 3AU.

Category of entry:

- Helpline       For Sale  
 Wanted       Pen Pals  
 User Groups       Other

Write your Advertisement here, one word per box.  
 Include your name, address and phone number if  
 you want them printed.

Please place my ad in the  
 next available issue of ACE.

Method of Payment

Name .....

- Cheque       P.O.

Address.....

Please make cheques and  
 postal orders payable to  
**ACE MAGAZINE.**

MAIL  
 ORDER

# SOFTSELLERS

MAIL  
 ORDER

6 BOND STREET, IPSWICH, SUFFOLK. IP4 1JE

5A DOGS HEAD STREET, IPSWICH, SUFFOLK.  
 (RETAIL)



36A OSBORNE STREET, COLCHESTER, ESSEX  
 (RETAIL)

**MAIL ORDER PURCHASE LINE (0473) 257158/210605 FAX NO : (0473)213457**

### JOYSTICKS

Cheetah 125 .....	£7.99
Cheetah Starprobe.....	£11.99
Pro 5000 Extra Glo Green .....	£13.99
Pro 5000 Extra Glo Red .....	£13.99
Pro 5000 Black.....	£11.99
QS Turbo 3 .....	£9.99
Euromax Racemaker .....	£24.99
Konix Navigator.....	£11.99

### DISC BOXES WITH DISCS

3.5" 40 Holder Lockable with 10 3.5" DSDD discs ...	12.99
3.5" 40 Holder Lockable with 20 3.5" DSDD discs ...	19.99
3.5" 40 Holder Lockable with 40 3.5" DSDDdiscs ...	33.99
3.5" 80 Holder Lockable with 10 3.5" DSDD discs ...	15.99
3.5" 80 Holder Lockable with 40 3.5" DSDDdiscs	35.99
3.5" 80 Holder Lockable with 80 3.5" DSDDdiscs	55.99

### PERIPHERALS

Replacement mouse + mouse holder + mouse mat .....	£29.95
Four Player Adaptor .....	£5.95
Mouse Mat .....	£4.95
Joystick Extender .....	£5.95
Dust Cover .....	£4.95

### DISCS

Quantity	10	20	50	100
3.5" DSDD Unbranded	£7.99	£14.99	£34.99	£59.99
3.5" DSDD Sony Branded	£11.99	£22.99	£54.99	£99.99

### DISC BOXES

3.5"	40 Holder Lockable	£5.99
3.5"	80 Holder Lockable	£7.99
5.25"	50 Holder Lockable	£4.99
5.25"	120 Holder Lockable	£6.99

CHEQUES AND POSTAL ORDERS PAYABLE TO SOFTSELLERS. POST AND PACKING FREE IN UK OVERSEAS £1.50 PER  
 ITEM. Subject to availability and price change without notice. \* Some titles may not be released at time of going to press.  
 Shop prices may vary, but personal callers can claim advertised discounts on production of cut - off slip.

# The BLITTER END

## CD-I FIGHTS BACK!

**A**fter the launch of Commodore's CDTV multimedia baby (as exclusively revealed in ACE 34), Philips and Sony have hit back with two shock announcements at last month's Compact Disc Interactive Conference in London. At launch, all CD-I players will have Full Motion Video (FMV) capability. Sony has also developed a series of revolutionary portable CD-I players (see page 6 for further details). The success or failure of CD-I could lie in these two attributes – digital video and portability.

With a FMV CD-I disc you can actually 'play' a movie – in high quality digital audio and video. With a portable CD-I player you can 'play the movie' on the bus, train or anywhere you like. Could this be the ultimate in Advanced Computer Entertainment?

The CD-I conference was an impressive event sponsored by the big boys – Philips, Sony, Matsushita Electric and Polygram. Held at the Royal Lancaster Hotel in London. No expense was spared. A free bar and all the food you could eat. ACE's Steve and Rik certainly enjoyed themselves! But there was more to it than satisfying the basic needs of journos. The conference was held to show the potential of the medium of interactive CD. And the guys were there in force. Speakers included J Timmer (President of Philips), G Stulberg (Chairman of American Interactive Media), I Maxwell (President of Maxwell Communications – and son of the massive media mogul), N Idei (Director of Sony) and M Higashi (Director of Matsushita). Delegates included representatives of Walt Disney, BBC, Time Warner, CBS, RCA/Columbia, Yorkshire Television, NEC, Sharp, Toshiba, Thorn-EMI, JVC, Hitachi, Fujitsu Ten, Olivetti, Yamaha, Decca, Motorola, Epson, ICI, Cray, Rediffusion, Nimbus, Barclays, Lloyds, British Library, Dai Nippon, Ricoh, Fiat, Renault, Volvo, Ordnance Survey and Commission of EC. You could smell the money.

A surprise delegate was Amstrad – could this British electronics manufacturer be working on a low cost CD-I player?

So the race is on. Which multimedia machine will hit the

mainstream first... CDTV or CD-I? If Commodore can deliver mass world-wide stocks of the CDTV by Christmas it will have the edge. CD-I will take at least another six months to hit the stores. Both decks are promising 100 titles at launch.

But which one will succeed? No one can say for sure at the moment. It could all rest on a battle of the marketing budgets. And the likes of Philips, Sony and Matsushita Electric definitely have the bucks and experience to promote their new baby to the max. Commodore on the other hand, took four years to get the marketing of the Amiga right. Watch this space...

### MEANWHILE, THE MEGADRIVE...

It's here! Or at least it has been launched in Europe. The eagerly awaited 16-bit Sega console is due in the UK in September. And those nice guys at Virgin/Mastertronic paid for a bunch of journos, retailers, distributors and other freeloaders to party in Paris. Of course, Rik 'that freebie is mine' Haynes stole his place on the trip.

While everybody stuffed down sushi and sake, they watched a simulated sado-sex show with Kendo wrestler's, a geisha girl and two trampolinists. The whole setting was straight out of the cult 60s TV show, *The Prisoner*. Bright red decor, 17th century building, girls dressed in *Barbarella* outfits, guys in Beefeater costumes, and a press pack made out of a strange blue material probably sold in sex shops. All that was missing was the giant inflatable ball bouncing around the stage. After getting pissed it was back to the hotel – and the picturesque view of the local graveyard. Obviously a fun time was had by all!

But enough of this. Here are the facts. The Sega Megadrive console will cost £189.99 and come with the *Altered Beast* game. The price of Megadrive games will range between £29.99 and £39.99 – there will be 20 titles available at launch, including *Golden Axe*, *Ghouls 'n' Ghosts*, *Super Hang-on*, *Revenge of Shinobi* and *Super Thunderblade*. The Power Base adapter – allowing you to use Sega Master System games on the Megadrive – will sell for £39.99. A minimum of two Megadrive games will be released per month. There are approximately 50 Megadrive titles currently available in Japan. The Megadrive will be launched at the CES show in September 13-16 in Earl's Court, and available in the shops around that date. All the major stockists will have it. That's all for now.

● Blit-Blit

## ACE IS THREE!

- We're celebrating hard and fast next month with our special third anniversary issue.
- We're improving and enlarging our computer, console and CD games coverage from the next issue.
- ACE is visiting Russia to discover how the Soviets managed to write the best computer game in the world! Are there any games better than *Tetris* currently in development? You can find out next month.
- Do you want a free trip to Austin in Texas? Do you want to meet Lord British – the creator of the *Ultima* series of fantasy role-playing games? Do you want to celebrate Halloween in style? Just enter the exclusive Origin/ACE competition next month and you may just win your dreams!
- The acid guru of the 60s is set to become the infotech guru of the 90s. We hope to see Timothy Leary and his computer software that enables non-spoken communication between humans.
- Look out for ACE 36 from Thursday 3 August.

### ACE CAPTION COMPETITION NO 2

We all know Ocean's Gary Bracey has got balls – but this is ridiculous! If you can come up with a witty line or two to fill an imaginary bubble above Gazza's head, let us know on a postcard and we'll send a mystery software prize (worth at least £20) to the sender of the one that makes us laugh loudest. Send your entry to ACE Captions, EMAP Images, Priory Court, 30-32 Farringdon Lane, London, EC1R 3AU.



Natural and responsive player movement and with the most simple of one-touch joystick control ensures exciting and authentic soccer action. Realistic close-ball control, computer aided team control and the micro's constant "flow of play" monitoring all add up to make this the easiest yet most rewarding soccer game ever devised for the home computer.

**TAKE ON THE WORLD!** Choose your opponents from the 24 World Championship teams - each have their own styles, strengths, and idiosyncracies! You will delight at the on-screen action, realistically flowing animation, automatic team response and the easy to follow on-generated action choices. This game is the choice of all football players, those who love playing the game instead of wrestling with the joystick...

adidas CHAMPIONSHIP FOOTBALL  
**YOU MAKE THE PLAY!**

...n 'em to the base line, attack the net and volley the winner! You might have taken this match but that's as on grass - can you play as well on clay or on the indoor courts?... with TIE-BREAK you'll soon find out! And the play selection doesn't end there - play singles or doubles, select to play in all the major tournaments such as Wimbledon, Davis Cup, French Open and many more. You can then make a racquet selection -and that could win you the match! Featuring all the shots in the book, breathtaking animation and amazingly realistic speech and sound effects in T.V. style presentation make TIE-BREAK the out and out winner on any micro.

AVAILABLE FOR  
SPECTRUM, AMSTRAD,  
COMMODORE, ATARI ST,  
AND AMIGA.

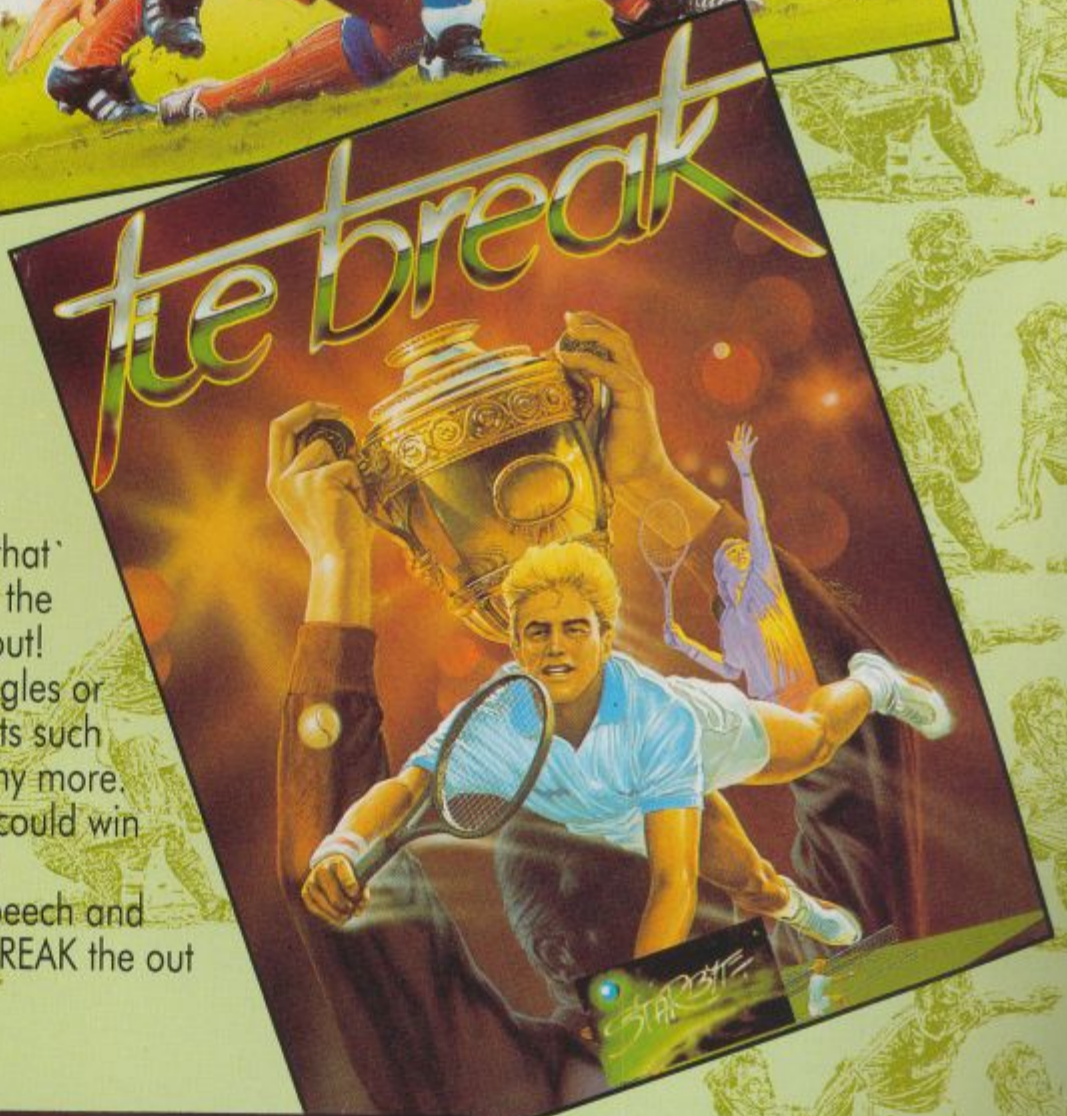
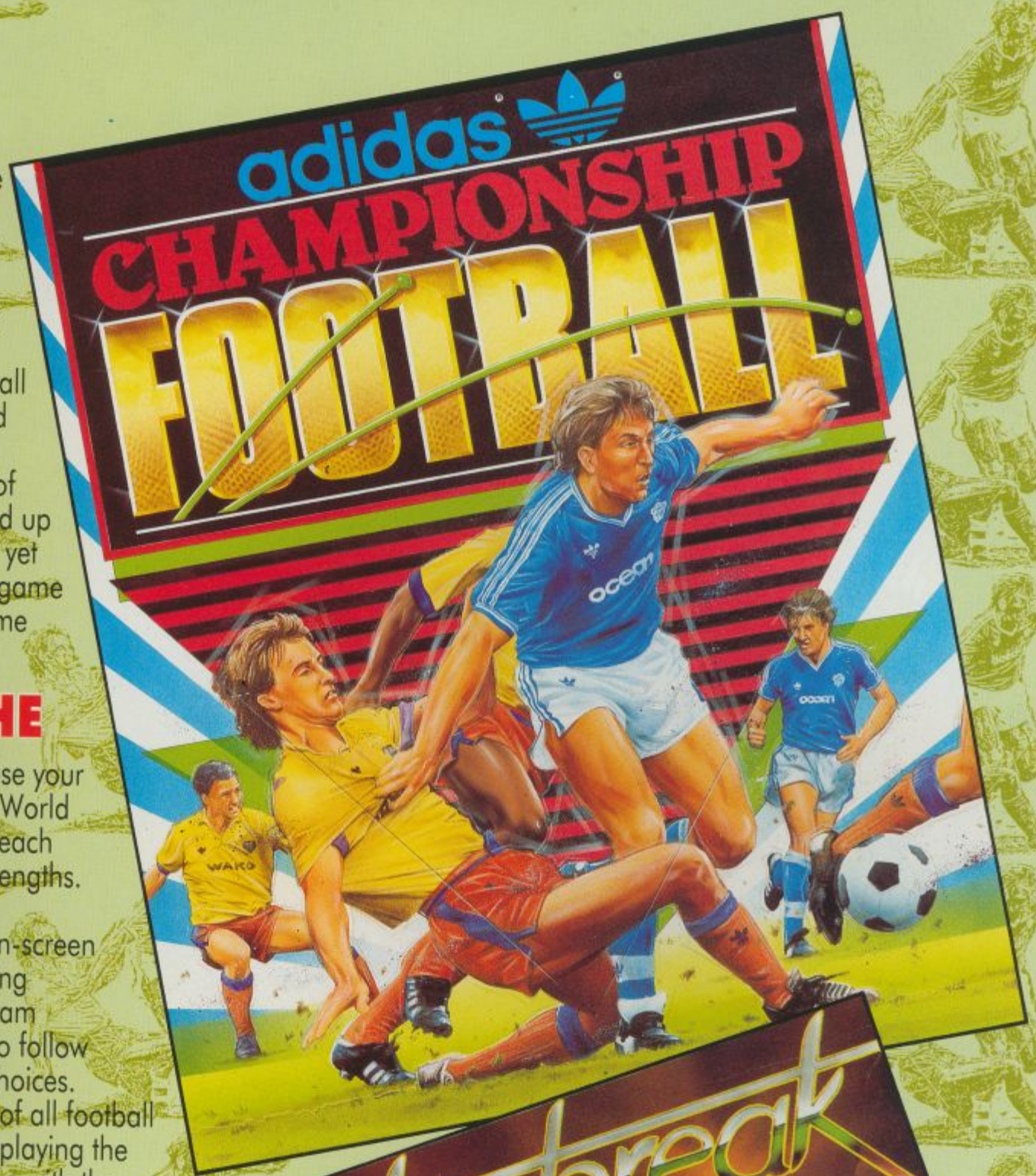

6 Central Street · Manchester  
M2 5NS · Tel: 061 832 6633  
Fax: 061 834 0650

# SNOWSTRIKE

MISSION ZONE COLOMBIA - MISSION TARGET DRUGS!



.... U.S. CONGRESS IN EMERGENCY SESSION - MOTION TO DECLARE WAR ON COLUMBIAN DRUG BARONS NARROWLY DEFEATED .....

.... COVERT OPERATION PLANNED BY MILITARY. U.S. CARRIER SETS SAIL FOR GULF OF PANAMA.

.... DRUG BARONS READY TO SHIP THEIR LARGEST EVER CONSIGNMENT OF THE DEADLY COCAINE OR 'SNOW'.

.... DAWN. SQUADRON OF F14 JETS TAKE OFF FOR COLUMBIAN COAST. THE TIME FOR TALKING IS OVER - AND YOU WILL MAKE THE FIRST SOLO ATTACK!



**EPYX**<sup>®</sup>

Available on:  
CBM 64/128 Cassette & Disk  
SPECTRUM & AMSTRAD Cassette  
& Disk · ATARIST · AMIGA  
· IBM PC & COMPATIBLES.

**U.S. GOLD**

U.S. GOLD LTD, Units 2/3 Holford Way, Holford, Birmingham B6 7AX. Tel: 021 625 3388.

Screen shot from STARR ST. version.