

# EDGE

DREAMCAST ■ PLAYSTATION ■ NINTENDO 64 ■ PC ■ ARCADE ■ ONLINE

## IS THIS **GAME OVER** FOR NINTENDO?



INSIDE: THE BIG N'S **TWO** NEW MACHINES  
**MIYAMOTO'S** FUTURE PLANS  
THE DEATH OF THE **64DD**

**PREVIEWED:** DINO CRISIS • GRAN TURISMO 2 • OMIKRON • DEAD OR ALIVE 2 • BRAVEHEART • JUMP RUNNER

**REVIEWED:** ALIENS VS PREDATOR • BLUE STINGER • X-WING ALLIANCE • UM JAMMER LAMMY • THE HOUSE OF THE DEAD 2

SCORE<1> HI-SCORE SCORE<2>  
0090 9370



---

6 CREDIT 08



**T**he answer to the question posed on this month's cover is an emphatic 'no', of course. But it *is* becoming increasingly difficult to see Nintendo achieving its aim as the new millennium approaches – that is, to wrest the control of the videogame industry back from Sony, which entered the hardware market just four-and-a-half years ago and proceeded to trample all over the company's dreams.

The announcement of Sony's next generation PlayStation has forced Nintendo to publicly admit the existence of its new console at a time when it should be looking to serve its N64 userbase with games of *Super Mario 64* quality. But such software is becoming thinner and thinner on the ground.

At this spring's Tokyo Game Show (see p52), only 2.9 per cent of the software on offer from thirdparty developers was N64-bound. True to tradition, though (last year aside), Nintendo will hold its own event, Space World '99, in August, where it will no doubt pull a number of surprises out of the bag. Despite recently intimating that it would finally be showing software for the 64DD (above) at the event, however, an **Edge** source has revealed that this simply cannot happen (read the full story on p7). One thing is certain: Nintendo will need more than a brace of new *Pokemon* titles at Space World if it is to remain a rival to the rumbling steamroller that Sony has become.

The N64's life to date has been fraught by delays, cancellations and disappointments. But it has also brought with it some of the most visually dazzling, technically innovative and simply delightful videogames.

Though the machine's death knell can already be faintly heard in the distance, **Edge** can't help feeling that the N64 hasn't been served justice. Here's hoping Nintendo's next machine (see p6) will fare better.

## Contacts

### Editorial

#### Future Publishing

30 Monmouth Street  
Bath, BANES, BA1 2BW

Telephone: 01225 442244

Fax: 01225 732275

Email: [edge@futurenet.co.uk](mailto:edge@futurenet.co.uk)

Recruitment: [chris.hall@futurenet.co.uk](mailto:chris.hall@futurenet.co.uk)

### Subscriptions

#### Future Publishing Ltd

FREEPOST B54900, Somerton  
Somerset TA11 7BR

Telephone Customer Services:

01225 822510

Telephone Customer order line:

01225 822511

Fax: 01458 274378

Email: [subs@futurenet.co.uk](mailto:subs@futurenet.co.uk)

### People on Edge

Tony Mott editor

Caspar 'Thud' Field deputy editor

João Sanches reviews editor

Jon Jordan writer

Jane Bentley production editor

Terry Stokes art editor

Darren Phillips designer

Nicolas di Costanzo Tokyo bureau

Chris Haill advertising manager

Neil Abraham display advertising

Amar Hussain classified advertising

Chris Haill recruitment 0171 317 2604

Advertising fax 0171 486 5678

Zoë Rogers senior technical coordinator

Lou Refell production manager

Production fax 01225 732293

Sarah Orchard ad design

Amy Miller print services coordinator

Judith Green group prod manager

Rachel Spurrier pre-press coordinator

Simon Windsor, Mark Gover,

Jason Tittley colour scanning

Chris Power foreign licenses

Jackie Garford publisher

Jane Ingham publishing director

Greg Ingham managing director

### Colour reproduction

Colourworks Repro, Bristol

Phoenix Repro, Bath

### Print

Cradley Print, Warley,

West Midlands

Edge is printed on Royal Press

90gsm

### Production of Edge

Hardware Power Macintosh, G3,

PowerBook, Quadra by Apple

Software QuarkXPress, Adobe

Photoshop, Macromedia FreeHand,

Pixar Typestry and Nisus Writer

Typography (Adobe®)

Formata light/regular/medium/bold

Vectora light/bold/black Base125ans/

bold/Univers Ultra Condensed

Fifth colours: Pantone®

Cover 8403 / Sections 8400 / 877

Edge recognises all copyrights in this

issue. Where possible, we have

acknowledged the copyright holder.

Contact us if we have failed to credit your

copyright and we will be happy to correct

any oversight.

EDGE is the registered trade mark of Edge

Interactive Media Inc. Used under license.



Printed in the UK  
© Future Publishing 1999

ABC (Audit Bureau of Circulation)

## Game Over? Or Game On? 06

Edge tracks down hard details concerning Nintendo's next machines, and reports on the passing of the 64DD

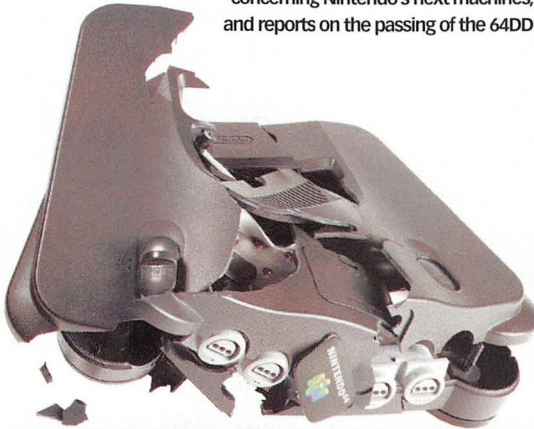

## Tokyo Game Show 52

The biggest games from this spring's expo in Japan

今回のゲームショーでは  
次世代プレイステーション  
に関する出展はしていません。  
ご了承下さい。

Please be informed that there are no displays regarding the next generation PlayStation at this show. Thank you.

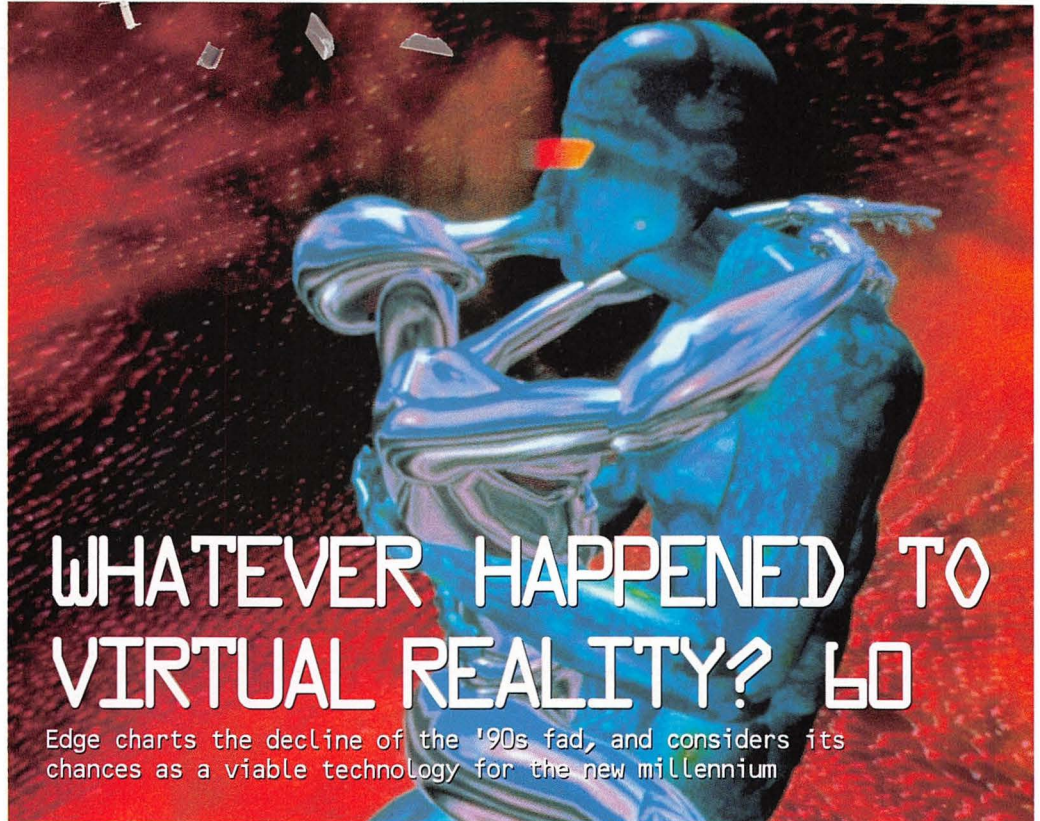

## WHATEVER HAPPENED TO VIRTUAL REALITY? 60

Edge charts the decline of the '90s fad, and considers its chances as a viable technology for the new millennium



## Eagle Dynamics 46

Corruption, venomous vodka and a flight sim in Russia

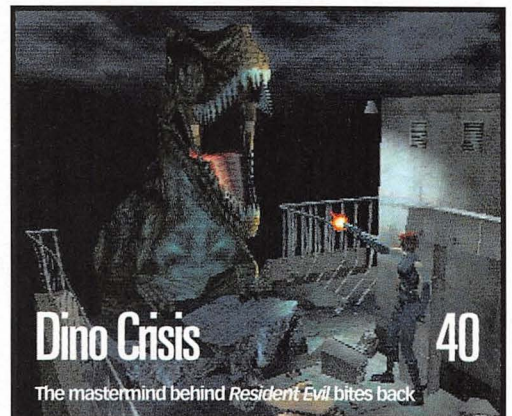

## Dino Crisis 40

The mastermind behind Resident Evil bites back

## TESTSCREEN

The world's most honest, accurate videogame reviews

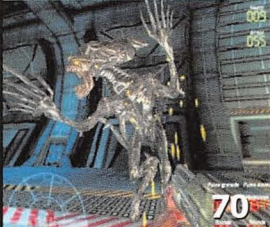

70



72



74



76



79



80

Aliens Vs Predator	70
Blue Stinger	72
Aero Dancing	74
X-Wing Alliance	76
Redline	78
Um Jammer Lammy	79
Duke Nukem: Zero Hour	80
The House of the Dead 2	70

## PRESCREENS 15

Metropolis Street Racer, Urban Chaos and Armorines in Alphas, plus the ambitious Flanker 2.0, Jump Runner and Tokyo Highway Battle



16



26



28



## Omikron 36

Already two years in development, parallel dimensions, a plethora of different locations and a world-renowned musician go some way to explaining the scale of this project



an audience with...

Lost Toys

106

### 06 News

Death of the 64DD, and Nintendo's plans for its N64 successor and new handheld; next generation PlayStation developments

### 15 Prescreen

'Star Wars' strikes back in Alphas, while **Edge** visits Paris to catch up with *Omikron* and travels to Russia for an insight into flight simulation

### 69 Testscreen

*X-Wing Alliance* and *Aliens Vs Predator* dish up thrills on the PC, *Blue Stinger* disappoints, but *The House of the Dead 2*'s a Dreamcast chiller

### 82 Develop

Demis Hassabis continues his exclusive diary; SN Systems talks about its programming tools for the next generation PlayStation

### 84 Edge Moves

Your chance to be a part of the videogame industry

### 106 Audience With

Fledgling Bullfrog break-off group, Lost Toys

### 112 Gallery

### 114 Arcadeview

Sharp-shooting *Silent Scope*; *Metal Slug X* and *GigaWing* work hard for their money

### 116 Retroview

Electric Dreams' long-forgotten 8bit title *Aliens*. Plus **Edge** View and Pixel Perfect

### 118 Out There

Consumer Tech, Reportage and Media

### 128 Viewpoint

### 130 Over the Edge

# Cutting Edge

The latest news from the world of interactive entertainment

## NINTENDO INSIDER CITES NGPS-BEATING PERFORMANCE

N64's successor to better Sony's recently revealed technology as Nintendo commits to new storage medium



Nintendo's Kyoto-based HQ is home to some of the industry's best-kept secrets, not least of which being a Sony-beating superconsole

### NGN OPINION

Edge spoke to a prominent N64 developer, who wishes to remain anonymous, to get his take on the NGN: "Every year you expect power to double. Nintendo's machine will not offer double that of the NGPS, but it is going to be a year later. Sony is shipping development systems to Japanese companies now. Apparently there are no Nintendo systems in existence and there won't be until at least the end of the year. I think Nintendo still has a chance, I don't think it's going to screw up, but I think that Sony's going to win everything. Sony is already in the DVD market, whereas Nintendo isn't, so I think that it's a done deal: Sony makes DVD players, Nintendo doesn't; Sony owns some of the patents on DVD, Nintendo doesn't. Sony is better placed to capitalise on the DVD market."

**A**n insider at Nintendo has revealed to **Edge** that the company's new machine already has performance to outstrip that of Sony's next generation PlayStation (see **E70**).

**Edge's** source also confirmed that the new format will eschew the company's long-favoured cartridge storage medium in favour of DVD-ROM, and that the system will be built with connectivity – via the Internet – as a core asset.

The source, who wishes to remain anonymous, refutes the suggestions recently made by many industry insiders, who claimed that the unveiling of Sony's next generation PlayStation demos (see **E70**) had forced Nintendo to "go back to the drawing board" in its own hardware development. **Edge** posed the question to its insider source: Hasn't Sony's recent demonstrations forced Nintendo's engineers to rethink their strategy? "No," was the confident response, "the specs haven't changed at all."

### Software issues

Nintendo has for some time been working with ArtX, a break-off group from Silicon Graphics Inc. (which famously provided the guts for the original Nintendo 64), to provide replacement technology for its struggling 64bit format. While Nintendo's outward stance has remained firmly committed towards its existing consumer base (the company claims it will hit an installed figure of 30m by the end of this year), **Edge's** source revealed that a significant proportion of the company's internal resources are concertedly focused upon developing libraries and, more significantly, software for a new home format.

Of all the hurdles Nintendo will face with its new hardware, software support will be the most significant. Despite once counting the likes of SquareSoft, Namco and Capcom among its staunchest supporters during the 16bit era, Nintendo failed to bring the most creative thirdparty Japanese powerhouses to its 64bit format with any degree of conviction – Namco's biggest commitments, for instance, having been Japan-only baseball games.

Nintendo's new-found appreciation of the value of disc-based storage is no doubt intended to engender it to the development community that so lovingly embraced the PlayStation. Sony may

**Nintendo's new-found appreciation of the value of disc-based storage is no doubt intended to engender it to the development community that so lovingly embraced the PlayStation**

The new DVD-ROM machine is expected to launch in Japan in November 2001 (Nintendo has a long-standing tradition of launching major hardware and software releases on November 21), but there is no indication of a possible name for the format to date.

A rumour recently circulating within the upper echelons of the industry suggested that Nintendo was set to release its new format as a no-thirdparty-software machine, leaving sole responsibility for games to the hardware manufacturer itself, but superpublisher Electronic Arts is now known to be working with the machine, while Texas-based developer Retro Studios is working on dev tools, and Acclaim has committed to publishing titles for the format.

have already run too far with the ball for Nintendo to ever regain the market-leading position it once enjoyed, but as **Edge's** source at the company put it: "It's not over yet. Not at all."



With DVD-ROM, Nintendo has finally embraced disc storage

## 64DD DIES AS NEW NINTENDO HANDHELD LOOMS

Nintendo's revolutionary add-on is scrapped as the company focuses energy on a Game Boy successor

**D**espite Nintendo having not announced the unit's official demise, **Edge** can confirm that the company's hardware engineers have canned the 64DD, the proposed N64 add-on storage device first mooted by the company way back in December 1995.

Nintendo has invested millions in the development of the 64DD, and its passing is a major blow for a company which, from the mid '80s to the early '90s, called the videogames market its own.

The 64DD, which used 64Mb discs (of which 32Mb was writeable by the user), was to form the heart of the 'Evolving Video Game Machine' – as Nintendo once termed the N64 – but uncertainty regarding the reception such an add-on would receive in today's plug'n'play mass market, plus lack of software commitment, sealed its demise.

**Shigeru Miyamoto** once claimed that "[Nintendo] will develop a lot of games that require both cartridge and disc, simply because of the potential to make greater games," and the company actually released *F-Zero X* with 'hooks' which would allow it to pass and receive data to and from the 64DD drive, but such an initiative is now set to go down in history as just another one of videogaming's pipe dreams.

Nintendo had in fact completed work on various 64DD projects, including those that would make up its *Mario Artist* series, but is simply putting much of its development work down to experience, according to a Nintendo insider. Titles such as creativity package *Picture Maker* will be resurrected and re-engineered in cartridge form at some point (Miyamoto-san has recently spoken of his involvement with such a title), if only for the Japanese market, while *Mother 3* and *Super Mario RPG 2* – the two biggest actual games in development for the 64DD, the bulk of whose content is being created by external teams – will definitely make it to market in stripped-down form in the future. Again, however, it's not clear whether or not they will officially make it to the west.

### Handheld horizons

Replacing the 64DD as Nintendo's secondary slice of forthcoming hardware is a new handheld machine whose software Miyamoto-san has confirmed he is working on.

Unlike the Game Boy Color, the new machine is not expected to be backwards-compatible with any existing



Working 64DD units exist (in uncertain numbers), but will never be released



Following the success of its Game Boy range, Nintendo is continuing its heavy investment in handheld gaming. Will its new unit look like this? (No)

Nintendo software. Rather, it appears that the company has taken a step back to appraise the profitability and, more importantly, longevity of the handheld market, and prepare a format which will fall somewhere between the SNES and N64 in terms of performance.

In terms of revenue, the handheld market is more important to Nintendo than the home console market by a huge margin, and its continued commitment to portable gaming will certainly allow the company more prolific creative output.

### Nintendo in trouble

With the cancellation of its power-bolstering 64DD, Nintendo will fight its opposition – Sega's Dreamcast, due in the UK on September 9, and the next generation PlayStation, expected to hit Japanese retail in December – with a piece of hardware whose performance is beginning to look creaky.

When Nintendo prepared to launch the N64 in the summer of '96, company

### 64DD TIMELINE

- December '95**  
'Bulky' drive details released
- February '96**  
64DD release 'set' for late '96
- June '96**  
N64 released in Japan
- November '96**  
First appearance of 64DD at Shoshinkai Exhibition. Games are conspicuously absent
- November '97**  
**Hiroshi Yamauchi** apologises for "slow development" of the 64DD. A release date of summer '98 is rumoured
- August '98**  
November release date for 64DD is set for Japan
- October '98**  
NOA president Howard Lincoln confirms indefinite postponement of 64DD outside Japan
- November '98**  
*Zelda 64* released in Japan as cartridge-only game
- March '99**  
64DD pronounced dead



Zelda 64 was set to be the 64DD killer app, but was forced on to cart. Shigeru Miyamoto has since called it the high point of the N64's life



The 64DD was to take the N64 in new directions, with add-on carts offering video-input capabilities. Such initiatives have since been dumped, however

president Hiroshi Yamauchi boasted that as far as software was concerned it would be a strict case of quality over quantity. In retrospect, this policy was rather weakly enforced, but the N64 does possess a handful of games that will be remembered as some of the greatest ever to grace a console. At this point in time, however, the machine's future looks rather grim. A quick look at UK distributor THE's current release schedule for the rest of 1999 reveals a startling lack of titles – even weak ones. Of the 19 games listed to appear in the remainder of the year, only Rare's *Jet Force Gemini*, *Perfect*

*Dark* and *Donkey Kong 64* trio shouts triple-A quality. THE's roster is by no means a comprehensive list (*Resident Evil 2* and Boss Games' *World Driver Championship* are notable absentees), but it remains an indication of a rather chastened year facing N64 owners.

Ironically, Nintendo itself is offering little support. Out-of-house-developed offerings such as *Mario Party* and *Smash Brothers* are not going to radically alter the predicament facing the company's 64bit system, and *Super Mario 64 2* plus a new instalment to the *Metroid* series only amounts to two games, after all.

### Trailing behind

Nintendo is realising that it is rapidly running out of franchises to update its 64bit status. A healthy supply of original software is desperately needed for its current console if it is to face up to 128bit opposition over the next two years.

Unconventional architecture resulted in a lamentably small number of coders really getting to grips with the Nintendo 64, and, after only three years, a significant number of the machine's earliest devotees have been lured to the camps of Sony and Sega. Nintendo now faces one big hill to climb.



From top: *Donkey Kong 64*, *Perfect Dark* and *Jet Force Gemini*: three crucial future N64 titles

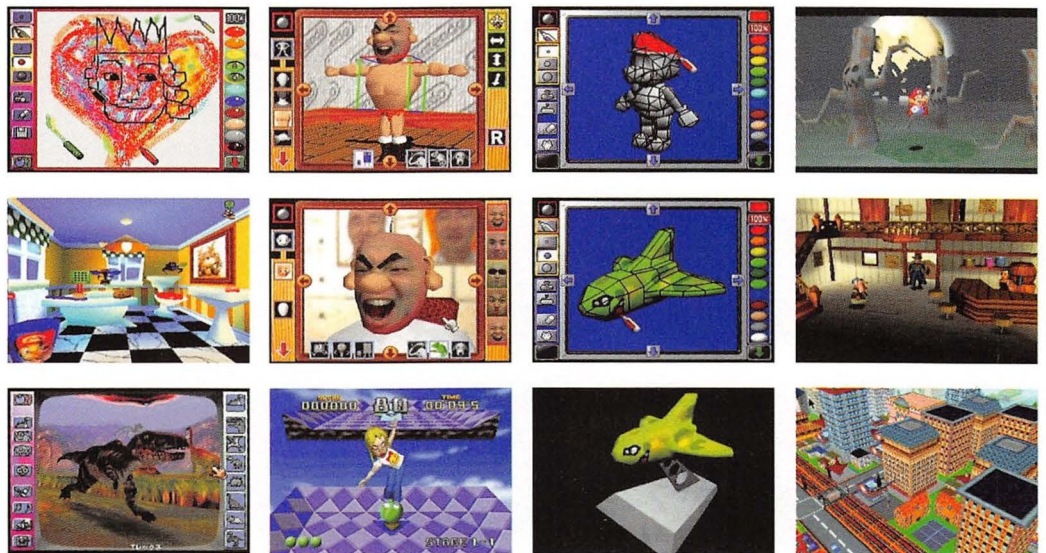

(Left column) *Picture Maker* was one of Nintendo's three proposed 64DD creativity titles. Software Creations led its production, and a streamlined version is now set for cartridge release. (Second column) *Talent Maker* would have encouraged the use of video input. (Third column) *Polygon Maker* was a relatively powerful modelling tool. (Fourth column) 64DD titles *Super Mario RPG 2*, *Mother 3* and *Sim City 64* are being re-engineered as cartridge releases



# MIYAMOTO RETURNS TO HIS ROOTS

The father of modern gaming makes an impassioned call for creativity

**S**peaking at the Game Developers Conference in San Jose, California, *Mario* creator **Shigeru Miyamoto** outlined his vision of the future for both Nintendo and gaming in general to a packed auditorium.

Miyamoto-san began by describing the shift in control of the creative process that has resulted from ever more powerful game systems. "In recent years, as I predicted, advancements in technology have once again brought programmers and engineers to the forefront of game design, and we are now in an age in which we cannot accomplish anything new without these individuals." The inference is that Miyamoto is feeling divorced from the creative process, something that industry commentators have long believed.

## Pioneering spirit

"People have paid me a lot of lip service... and have gone so far as to suggest that I try my hand at movies," he related. "But I feel that my strength lies in my pioneering spirit to make use of technology to create the best, interactive commodities possible, and use that interactivity to give users a game they can enjoy and play comfortably."

Aside from *Zelda: Ocarina of Time*, some of Nintendo's 64bit additions to its classic game brands have not matched expectations – particularly the disappointing *Yoshi's Story*. Miyamoto-san tacitly admitted this by saying, "Recently, I've encountered many instances in which we hit a brick wall in game



development, and never quite make it to completion. I believe many of you have at one time or another found yourself in the same boat, and may have even had no choice but to release a game to market in an incomplete or unsatisfactory condition.

"I am very sorry to see that the uniqueness of many titles has been dependent upon new technology and specialty development tools, while the personalities of the creators have been diluted," he added. "For me, game creation is like expression through music."

## Fresh approach

It seems that the sheer scale of his recent projects for Nintendo has caused Miyamoto to re-assess his approach to game creation. "Shall I begin making *Zelda* for our next generation hardware? At this point, the answer to that question is no," he stated bluntly. "With improved hardware, I can imagine *Zelda* having more detailed graphics and a quicker response time, but when it comes to increasing the degree of fun, I cannot be certain of that at this time," he explained, warning that, "This is something I feel we as designers must reconsider."

Miyamoto-san then demonstrated his latest project, "A newly born *Mario Paint*," while carefully revealing the path ahead

for NCL and its affiliates. "Nintendo will make efforts to create new types of commodities by combining the Game Boy, the Game Boy Camera, the Rumble Pak and others with the N64."

## Plea for creativity

He then questioned the direction that the videogame industry was heading. "When we were stuck on the spectacular 3D graphics of *Mario 64* and racing games, we saw a huge hit in the form of *Tamagotchi*," he pointed out. "I thought that *Mario 64* had lost to *Tamagotchi*."



**Miyamoto-san was greeted with a standing ovation at GDC. The feted creative is currently focusing his talents on handheld technology**

**"I am very sorry to see that the uniqueness of many titles has been dependent upon new technology and specialty development tools, while the personalities of the creators have been diluted"** Shigeru Miyamoto

Summing up, the father of modern gaming made an impassioned appeal to his industry counterparts: "My friends, let us design unique, fun software with new appeal... so that gaming is not left behind as a separate, closed-off world."

The success of Game Boy and the failure of the N64 has shaken NCL to its core. By offering Nintendo's customers greater flexibility and creativity, it seems Miyamoto-san is seeking to re-ignite his own – and increase his employer's profit margins in the process.

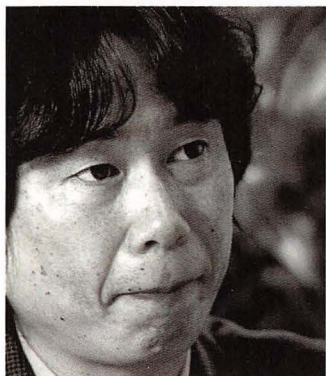

## SONY'S NGPS TO ATTACK PCS AND TARGET OLDER GAMERS?

Edge attends a Q&A session revealing Sony's plans for coin-op conversions, tackling piracy, and the potential of an untapped market



Ken Kutaragi (above), formerly EVP and co-COO, now replaces previous SCEI president and CEO Teruhisa Tokunaka (left) who moves over to the company's board



After the Q&A session, all of the NGPS demos were shown again, including the GT demo – in playable form, of course (above)

Shortly after the next generation PlayStation announcement – reported last issue – SCEI held a Q&A session for the world's videogaming press with then-SCEI president and CEO **Teruhisa Tokunaka**, executive vice president and co-COO **Ken Kutaragi**, and vice president of R&D, **Shinichi Okamoto**. Their comments show total confidence in the NGPS as an integral part of home entertainment for the future.

**"The NGPS will continue to be a games machine, obviously, but because of its many capabilities maybe it can be connected to other audio visual products in the future"** Teruhisa Tokunaka

**Q: What do you envisage achieving with the NGPS?**

**Teruhisa Tokunaka:** I see the PS and

NGPS standing side by side with all of the televisions in people's homes. The NGPS will continue to be a games machine, obviously, but because of its many capabilities maybe it can be connected to other audio-visual products in the future. For example, maybe you can take your own picture with a camcorder and modify a character in a game so that you will be the hero in the game. That's one of the things I can imagine happening.

**Q: How do you plan to tackle the inevitable problem of piracy?**

**Ken Kutaragi:** This is a very, very serious issue so we're obviously going to incorporate any kind of system possible, but naturally we're not about to explain the intricacies of such a system.

**TT:** From a legal standpoint, we're pursuing some of the sources of piracy in some of the Asian countries, so we've been working very energetically during the last three years with the police and governmental organisations, and I don't know how many litigations have been issued in those countries. The best solution, obviously, is an engineering rather than a legal solution, so I would like us to continue to work on it to make

it more and more difficult to pirate software. That is very, very important, not only for us but also for the industry.

**Q: Are you not worried that there may not be enough time for developers to get their respective games ready for the launch?**

**TT:** One thing is for sure: if the software is not ready there is no launch. We were concerned about whether the software would be ready in time for the Japanese PlayStation launch in December 1994, but actually, as we approached the March 2 release date, the quality of the code improved dramatically. The night before the announcement both Ken and I went to see the the [NGPS] demonstrations. Some of the software was clearly having some problem and I recall that some of the cars in the GT demo didn't have wheels... But I really admire the people that did them – 15 hours after we saw them there were dramatic improvements in all of those demonstrations. I was surprised, actually. Very surprised.

**Q: Are you expecting current PlayStation sales to suffer as a result of this announcement?**

**TT:** I think the people purchasing the PlayStation today are very different from the people who purchased the PlayStation initially. So I'm not concerned that the current PlayStation sales will be substantially affected by this



SCEI's top trio and the next generation PlayStation (in impressively compact dev-kit form) face questions from the world's gaming press

announcement. Because the NGPS is able to play current PS software I think the support from developers for the current software will be continued – it's much easier for software developers to invest their resources on the current PS. So I think many people will still be interested in acquiring the current PS.

**Q: Can we expect further price reductions for the PlayStation?**

**TT:** We can't currently comment on future pricing strategies, but I think that you can realise from our track record that as we improve our manufacturing capabilities we try to transfer that ability to the market and that increases it. That is what we've learnt over the last four years.

**"You can connect a keyboard and other peripherals. But I don't want the PlayStation to simply be a computer in the home, so the NGPS will be closely linked with the TV in the living room"** Ken Kutaragi

**Q: Are you envisaging arcade applications based on the NGPS?**

**KK:** If someone wants to utilise this technology for arcade use we can support it.

**Q: Do you expect the NGPS to replace PCs at all?**

**KK:** Because this system will have the USB interface you can connect a keyboard and other peripherals, so it's very, very possible. But I don't want the PlayStation to simply be a computer in the home, so the NGPS will be closely linked with the TV in the living room.

**Q: Are you confident that this**

**system will bring with it a totally new style of game?**

**TT:** We certainly hope those sort of games will be made – that is our dream. Mr [Norio] Ohga (Sony Corporation's chairman and CEO) told us some days ago about his secretary's father who is 58 years old with a law degree and working for one of the biggest trading companies as a senior executive. His daughter asked Mr Ohga if she could borrow his copy of *FFVIII* and he thought she would be playing it, but a few days later she came back and said that in fact it was her father who had been playing it. Mr Ohga was very impressed with this and he's been asking us to encourage the development of

software specifically targeting older consumers. His other reason for that is that his wife is a concert pianist and [at the announcement] he mentioned [Arthur] Rubinstein and others who had a very clear mind even past 90 years of age. His theory is that using your fingers is very good – and he believes that the PlayStation is a good thing for older people. But the unfortunate situation is that most developers are still very young, so I told him that maybe in 30 or 40 years from now, when programmers are in their 60s, he should expect plenty of software he can play. [Laughs]

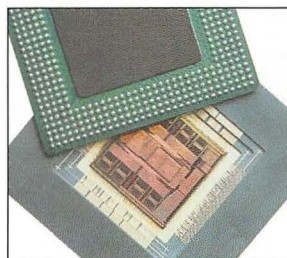
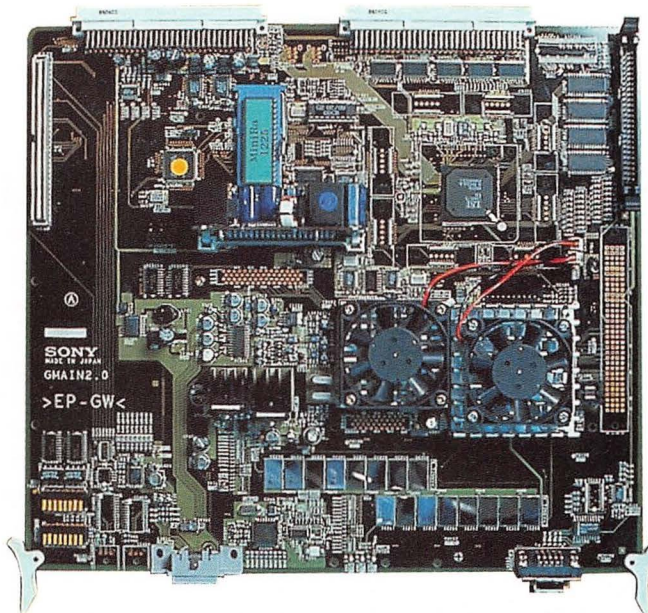

The Emotion Engine and Graphics Synth (above) are finished chips (which require a hefty amount of cooling during operation – see right) but the NGPS's internal architecture is still in the process of being tweaked

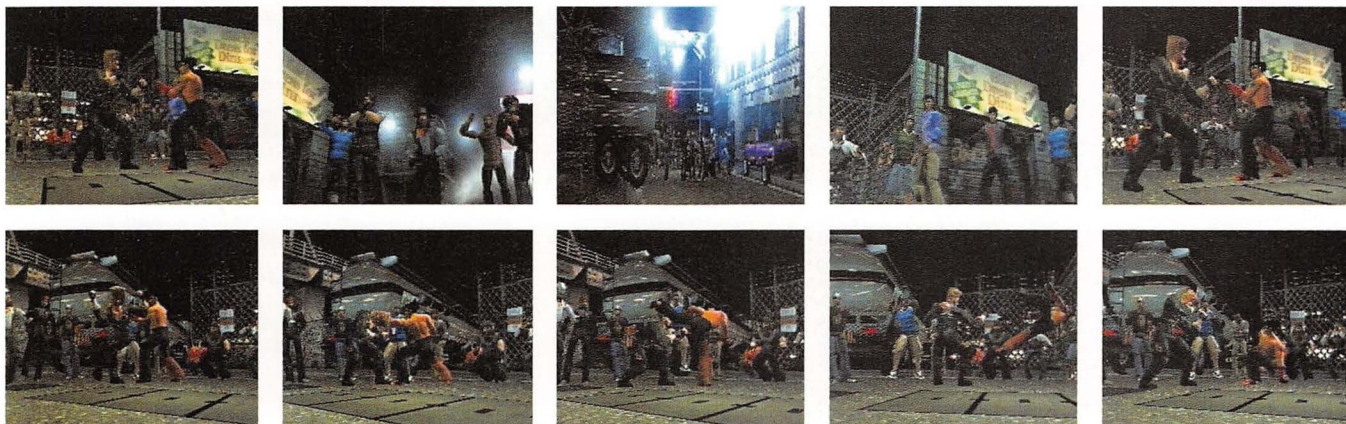
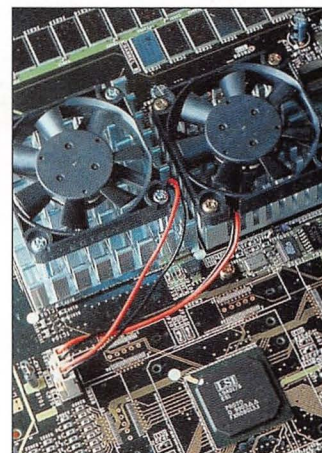

More images of Namco's *Tekken* NGPS demo shown at the announcement in March, conveniently illustrating the ludicrous level of detail present not only in the near-CGI quality of the two fighters but particularly in the realistic-looking area surrounding them, including the 30 fully animated onlookers

## PSYGNOSIS SHUTS UP CODESHOPS

Redundancies and branch closures hit superpublisher as Sony steps in

Once a multinational publisher of repute and considerable power, Psygnosis has now been reduced to a mere three studios in Sony's radical shake-up of the company. The latest twist in an almost inconceivable story came on March 25 when members of the Stroud development studio – responsible for *G-Police* and *Colony Wars* – were told that the office was to be shut down with immediate effect. A handful of staff have been kept on for three months to finish two projects – *G-Police 2* and *Nations* – but then they too will be made redundant. Further job losses and project cancellations have also been reported at the Liverpool HQ and London Camden studio, while Psygnosis' Paris branch is now owned by Infogrames. The company's Leeds-based studio,



however, remains virtually unscathed, despite the mediocre reviews handed out to its recent projects, *Retro Force* and *Global Domination*.

The extent of Sony's culling is perhaps most startlingly evident in Psygnosis' product line-up. Last year the company was working on around 60 titles; this year it will be closer to six. Big properties like *Wipeout*, *F1*, *G-Police* and *Colony Wars* now seem to represent a majority of the output. It is not known how the shake-up will effect deals with thirdparty developers such as Attention To Detail, responsible for the popular racer *Rollcage*.

With Gremlin recently swallowed up by Infogrames (see opposite), it has been a month of ups and downs for veteran British publishers. 



*G-Police* (top) and *Overboard* were two of the successful titles from Psygnosis' Stroud office

## DREAMCAST US LAUNCH PARTY

Sega cites 38 titles set to ship in the States by mid-2000

Sega of America has sent an interesting list of forthcoming Dreamcast games (below) to software retailers in the US. While some of the 38 titles seem highly unlikely to emerge (Argonaut denies any existence of a Dreamcast *Croc*), others such as *Hydro Thunder* from Midway are known to be in progress.

Quite where *Missile Command 3D* fits into the superconsole's brand values, meanwhile, isn't clear.

Extraordinary inclusions are *Grand Theft Auto 2* (a Dreamcast version has so far been denied by Take 2), *Shenmue* (due to the vast translation task needed), and, most bizarrely, *Ridge Racer Plus* and *Time Crisis II* from Namco – two titles that would be massively significant to Dreamcast's credibility in the west. 

In a related story, major American retailers such as Toys 'R' Us are believed to be preparing for a \$200 price point. European pricing is likely to follow the pound-for-dollar rule, indicating that the £200 first predicted in E62 is correct. Further speculation suggests that Sega Europe will bundle a modem with its version of Dreamcast in order to ensure that the console's network capability is fully exploited by developers. 

### DREAMCAST US RELEASE SCHEDULE

#### September 1999

The House of the Dead 2	Sega
NBA Basketball	Sega
NFL Football	Sega
Sonic Adventure	Sega
Super Speed Racing	Sega
Virtua Fighter 3tb	Sega
Hydro Thunder	Midway
Mortal Kombat 5	Midway
Ready 2 Rumble	Midway
Castlevania	Konami
Soul Calibur	Namco
Power Stone	Capcom
Croc	Fox Interactive
Alien Resurrection	Fox Interactive
Project Velocity	Acclaim
Missile Command 3D	Hasbro Interactive

#### October 1999

Evolution	Sega
Geist Force	Sega
Daytona USA 2	Sega
Shenmue	Sega
Sega Rally 2	Sega
Star Wars Trilogy Arcade	Sega
Marvel Vs Capcom	Capcom
Cool Boarders 3	UEP Systems
Grand Theft Auto 2	Take 2
South Park	Acclaim

#### Year 2000

Age of Empires	Psygnosis/Microsoft
Oddworld: Munchies Oddyssey	GT Interactive
Unreal	GT Interactive
All-Star Baseball	Acclaim
NFL Quarterback Club	Acclaim
Dead or Alive 2	Tecmo
NIGHTS 2	Sega
Zombie Zone	Sega
World Series Baseball	Sega
Ridge Racer Plus	Namco
Time Crisis II	Namco

## INFOGRAMES GOBBLES UP GREMLIN

French giant gets a bargain as Sheffield publisher finally gives up war of independence

**F**ollowing months of speculation about its future, Gremlin has accepted a cash bid from Infogrames. The French superpublisher offered 120p per share for the Sheffield-based company, valuing it at £23 million. When Gremlin first floated in 1996 it was worth £29 million. As over half of Gremlin's shares are controlled by directors Ian Stewart and Jenny Richard-Stewart, their acceptance gives Infogrames control of the company.

"There are exciting times ahead," stated **Ian Stewart**.

"Infogrames is a dynamic, ambitious group. Opportunities will be created." While the takeover is amicable, questions remain concerning the manner in which Gremlin will be integrated into Infogrames' UK structure. Job losses are expected to be kept to a minimum. However, there remains uncertainty concerning the position of Dundee developer DMA Design.

Fuelled by a war chest of £92 million, Infogrames has entered a period of aggressive acquisitions to allow it to compete with big American publishers on their home turf. The purchase of Gremlin effectively doubles the company's development strength. The potential of the *Actua* range of sports titles is another attraction. In turn, Infogrames' marketing muscle should bolster Gremlin's sales.

Ever since it floated on the stock exchange, Gremlin's share price has been under pressure despite its solid performance. It had become clear recently that the company



**Gremlin director Ian Stewart when he heard the news of the company's £23m sale to Infogrames**

needed a strategic partner to help develop its brands globally. Companies rumoured to be interested in acquiring it included Microsoft and Eidos. Take 2, meanwhile, had its eye on DMA if Gremlin was to be broken up.

News of the Infogrames bid came as other software companies quoted on the stock exchange have attracted increasing speculation. Eidos' share price continues to rocket, breaching the £20 barrier, while Sci, creator of the *Carmageddon* series, saw a 37 per cent rise in its share price during one week. Neither company admits to being up for sale. By contrast, Rage seems certain to be bought in the next couple of months, with Microsoft and EA rumoured to be among the front runners.



## PS EMU HITS PC AS SONY SUES

Another PlayStation emulator rocks Sony's boat as it attacks alleged BIOS infringement

**B**eating Connectix to the punch with a commercial PlayStation emulator for the PC is *bleem!*, whose optimisation makes it possible for owners of even P166-spec machines to run many PlayStation titles – and in greatly enhanced form when using a 3D accelerator card. Sony has yet to react to *bleem!*'s author ([www.bleem.com](http://www.bleem.com)), which is selling the software at \$25.

However, the Japanese giant *has* attacked ActionWorld Inc, the host of Dave's Classics ([www.ugo.com/daves](http://www.ugo.com/daves)), which Sony alleges infringed the PlayStation's BIOS by copying it and making it available as a download. A lawsuit has been served.



Although the minimum system requirement for *bleem!* is a P166 with 16Mb of RAM and a 16bit graphics card, it really comes into its own when running on high-end systems. The only way to improve *Gran Turismo* prior to the forthcoming sequel is with *bleem!* (right) – in this case running on a Voodoo Banshee card with Direct 3D

### CUTTINGS

#### Kurt's second coming

Interplay has confirmed *MDK2* will launch with Dreamcast in the US. BioWare (*Baldur's Gate*) is developing the sequel using its Omen engine. In addition to anti-hero Kurt, two additional playable characters, Max the robot dog and Dr Hawkin, will be introduced.

#### Silver screen support

In a move to increase the profile of its *Aliens Vs Predator* title, Fox Interactive is showing a one-minute trailer in United Artist theatres. It is the first time a major studio has promoted a game this way in the US.

#### Incoming to coin-op

Reversing the normal direction for games, Rage's *Incoming* will be unleashed into American arcades in June. "*Incoming* for PC is almost perfect, and we intend to make it perfect for the arcade," joked **Bruce Klein**, president of distributor Virtual Games.

#### Virtual PlayStation 2

With the power of the next generation PlayStation placing high demands on developers, Cygnus has released a new set of middleware tools. The software-based 'virtual platform,' distributed by Sony, will allow developers to begin creating and testing games prior to receiving the finished hardware.

#### More fame for Meier

The Academy of Interactive Arts and Sciences has announced that Sid Meier is the recipient of this year's Hall of Fame award. The creator of games such as *Alpha Centauri* and the *Civilization* series will be inaugurated at the annual ceremony during E3.

#### 007 Mk 3

With the next Bond film, 'The World Is Not Enough' opening in November, EA has confirmed that the game of the film will use id's *Quake III* engine in its PC incarnation. A PS version will follow.

#### Openings for WinCE

Microsoft continues its stalking of the games industry with news that Acclaim is developing a title using the Dreamcast-specific *WinCE* operating system. Other developers using *WinCE* include Konami, Hudson and Kalisto.



# Take your environment seriously.

Your environment's about to change forever. A revolution's taking place, with more people joining every day - the campaign for Environmental Audio.

What's it all about? Well shut your eyes for a moment and listen. Not only can you distinguish between different sounds, you'll also notice you can pinpoint their origin, hear them pass you and disappear - a sensation that can only be matched by Environmental Audio.

Developed by Creative Labs, Environmental Audio (EA) is the most advanced PC audio technology available. Inside every SoundBlaster Live! sound card and delivered through our FourPoint surround sound speakers, EA creates an interactive audio experience that's so realistic, every games environment you enter becomes your environment.

And with more games titles formatted for EA everyday, isn't it time you joined?

To find out more contact your local dealer or call 01245 265 265.



**Environmental  
Audio™**



**CREATIVE**

[WWW.SOUNDBLASTER.COM](http://WWW.SOUNDBLASTER.COM)

# PRESCREEN

EDGE PREMIERES INTERACTIVE ENTERTAINMENT'S FRESHEST FACES

## Lost in space

When big isn't always beautiful

**T**his is the age of the epic videogame. Driven onwards by the relentless advancement of 3D technology, game designers from Guildford to Kyoto are busy forging vast adventures for gamers to experience. Undoubtedly, the masters of this burgeoning art are the Japanese, thanks to years of toying with the potential of the RPG. *Zelda: Ocarina of Time*, *Metal Gear Solid*, *Final Fantasy VII* and *VIII* – not to mention the forthcoming *Shenmue* – are the aspirational titles of the late '90s. And in some respects they're stifling game design.

Since the ascendancy of PlayStation it has become fashionable among those in the know to deprecate the 'casual gamer'. Capable of playing a game for less than an hour, these soulless cattle have the audacity to switch on their consoles after returning from the pub. Some are rumoured to own less than five titles for their machine. Others have been reported to invite 'mates' to their homes and are seen enjoying themselves in front of their PlayStations. That they have no desire to scour the deepest recesses of Square's latest epic makes their sins even more unforgivable.

In truth, many of these massmarket videogamers do play and enjoy the *Metal Gear Solids* and *Zeldas* – as their sales figures indicate.

But while the games industry and hardcore players descend into disarray at the prospect of the next generation PlayStation and its implications for game creation, the casual gamers won't even notice. The most popular console on earth is the Game Boy, and one of the main reasons for its dominance is *Tetris*. A lesson lies therein.

Just because the next Nintendo and Sony machines are capable of delivering entire worlds to explore, it doesn't mean that every game must now be an epic. Capcom's *Power Stone* is a perfect illustration of how to create a superconsole title – the beauty of the game is in its simplicity. It would have been perfectly feasible for there to be an entire city in which to fight – but would it have enhanced the game? Probably not.

Nothing is more daunting than a world without limits – which is (more or less) what Sony and Nintendo are about to offer game designers. Just as the team behind *Power Stone* realised, the inventors of the next wave of interactive entertainment must mark out their own conceptual boundaries before work begins. Not every title has to be an epic, not every title can be *Zelda*. People like playing games. Gamers like epics. Which says it all.

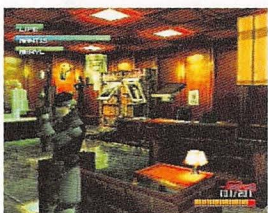

While Japanese developers steam ever onwards, striving for another 'epic' such as (from left) *Metal Gear Solid*, *Zelda* and *Final Fantasy VIII*, is the sense of what defines a true 'game' being lost?

### Edge's most wanted

Razor sharp games on the cutting edge



Metropolis

Dead or Alive 2

Dino Crisis

Legend of Mana

(DC) Bizarre Creations

(DC) Tecmo

(PS) Capcom

(PS) SquareSoft

Ever seen a brake calliper working in realtime? Real cars, real cities, relentless racing. Bizarre Creations' Euro-launch title looks set to be utterly stunning.

With a tag-team option and the prospect of more voluptuous, jiggling she-fighters, it was strangely difficult not to be drawn towards DOA2 at TGS.

Resurrecting dinosaurs might be old hat, but the terrifying prospect of facing intelligent, quick, bloodthirsty Raptors is another winning formula.

An old favourite makes a hugely welcome return on a platform that seems made for it. Expect swish graphics, a classic musical track and honed gameplay.

## Index

### Prescreen Alphas

page 16



### Gran Turismo 2

page 26

### Dead or Alive 2

page 28



### Jump Runner

page 30

### Tokyo Highway Battle

page 32

### Braveheart

page 33

### Silent Bomber

page 34

### Omikron: The Nomad Soul

page 36

### Dino Crisis

page 40



### Flanker 2.0

page 46

# PRESCREEN ALPHAS

THE LUCASARTS EMPIRE STRIKES BACK, AND BIZARRE CREATIONS RACES AHEAD OF THE PACK

## STAR WARS: EPISODE I RACER

FORMAT: PC/PS/N64/MAC DEVELOPER: LUCASARTS

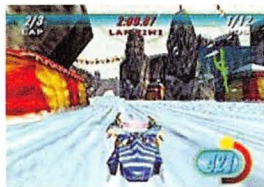
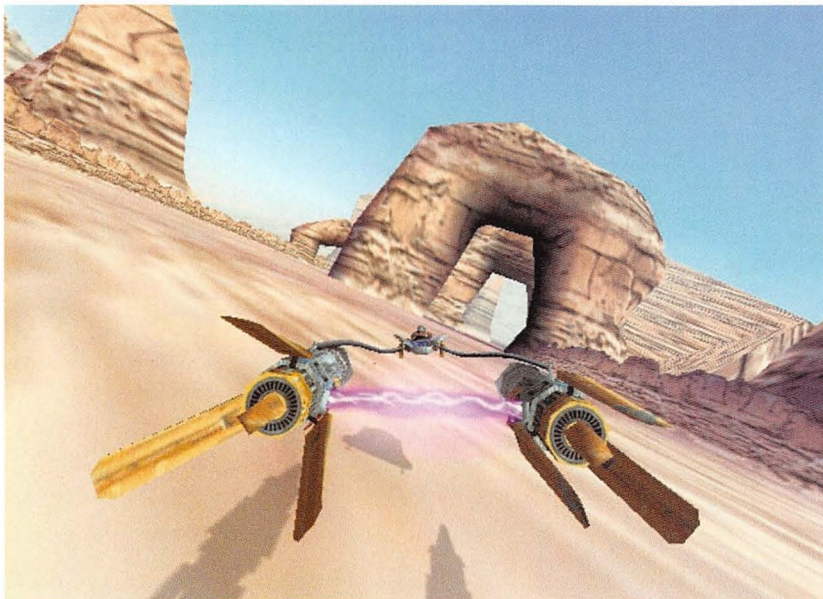

Based on the Podracing sequence in LucasFilm's forthcoming 'Phantom Menace', *Episode I Racer* sees you jumping into the cockpit of any of the 20 featured Podracers, including young Anakin Skywalker's. Races occur on eight interplanetary locations at speeds of around the 600mph mark courtesy of massive jet engines. Coming to a console/computer near you soon (PC shots shown), **Edge** hopes this isn't another sad case of 'if it moves and it's in the film, heck, we'd better make it into a shallow game...'



## METROPOLIS STREET RACER

FORMAT: DREAMCAST DEVELOPER: BIZARRE CREATIONS

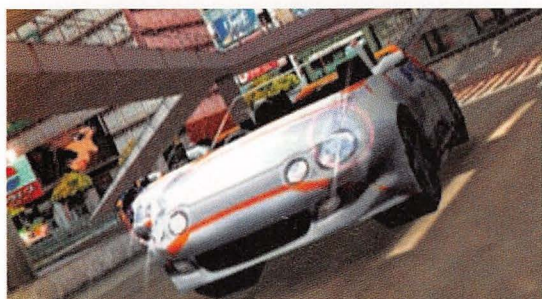
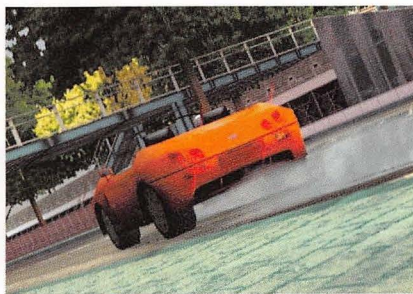
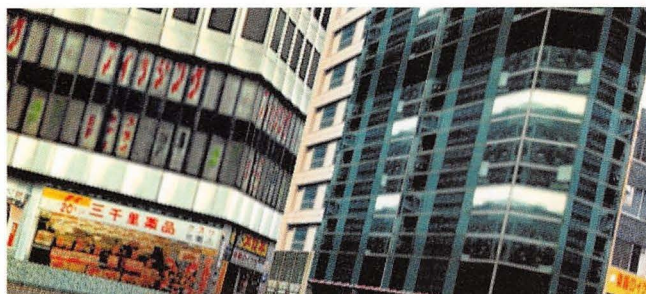

Just as this issue went to press, an **Edge** correspondent reported back from the official unveiling of *Metropolis Street Racer* (previously known as *Metropolis*) in Liverpool. As these shots reveal, the collision of Bizarre's technical prowess and the design skills of Sega producer Kats Sato (*Sonic R*, *Outrunners*, *Clockwork Knight*) has borne considerable fruit. Attention to detail is stunning: over 32,000 stills were used to help replicate the game's San Francisco, Tokyo and London settings, and apparently it's possible to see the 20-plus cars' brake callipers working through their alloys. Wow.

## STAR WARS: EPISODE I THE PHANTOM MENACE

FORMAT: PC/PLAYSTATION DEVELOPER: LUCASARTS



With the racing game taken care of (see opposite), LucasArts can concentrate on what could turn out to be the most interesting of the several 'Episode One' movie tie-ins the company is no doubt planning to pump out this year. Heavily based on the movie's plot, the game is to be given a simultaneous global release by Activision soon after the US cinematic premiere on May 19, partly as an effort to reduce the damage of piracy.

## ARMORINES

FORMAT: NINTENDO 64 DEVELOPER: PROBE

Following up its previous N64 titles *Forsaken* and *Extreme G*, UK-based developer Probe has borrowed the *Turok 2* graphics engine from sister company Iguana US to create *Armorines*. Set in Siberia, the game has you battling through waves of insectoid enemies to save humanity in a race against time. As you'd expect, there's a fourplayer mode, too.

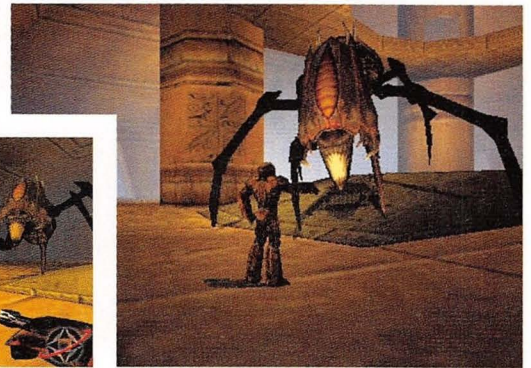
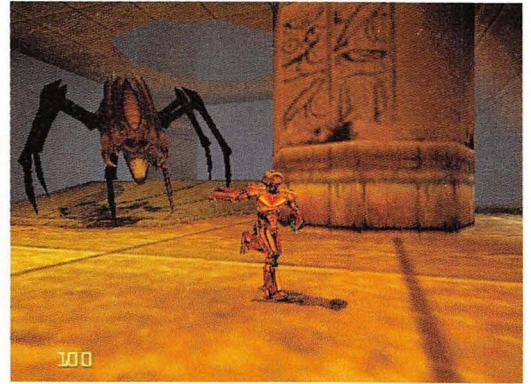

## URBAN CHAOS

FORMAT: PC DEVELOPER: MUCKY FOOT

Complete freedom of movement in a gritty post-millennial environment is the promise of Mucky Foot's *Urban Chaos*. The first offering from the ex-Bullfrog crew allows players to choose between a streetwise female or tough male. Combat is based around classic beat 'em ups, although, as is the vogue, stealth will be as important as brawn. Spatial awareness seems likely to be a crucial factor for avoiding trouble, too, as platform-style action is rumoured.

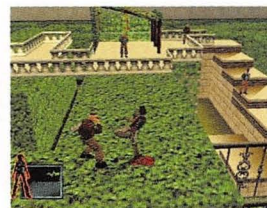
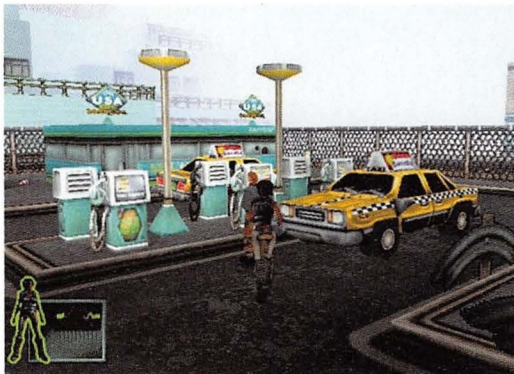

## ALIEN RESURRECTION

FORMAT: PLAYSTATION DEVELOPER: ARGONAUT

Heavily supported by publisher Fox Interactive, Argonaut's better-late-than-never movie license has no excuse other than to at least look like the film. Throughout the production schedules of the game and film, the Argonaut team has been given unprecedented access to footage, scripts and other materials. Judging by these shots, *Resurrection* has captured the dark feel of its source.

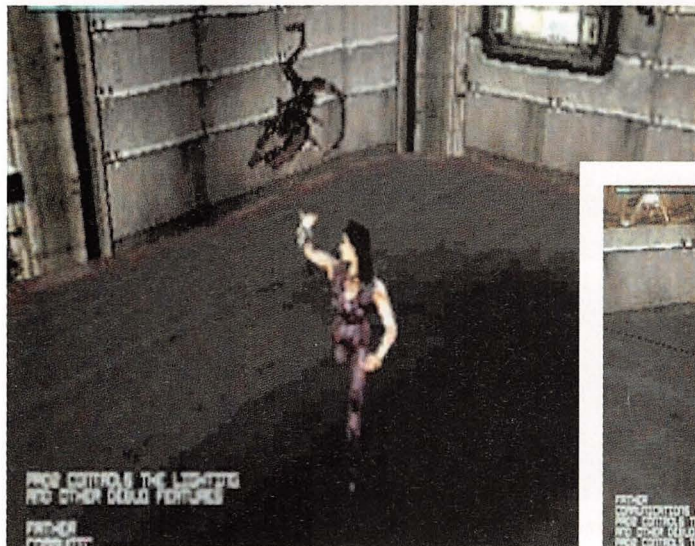

## SOUL REAVER

While PlayStation reviewable code is still non-existent (Eidos claims it's due at the beginning of May), here's a screenshot of the PC version to keep you up to date with Crystal Dynamics' intriguingly morbid project. And, if release schedules are to be believed (a proposition filled with danger), PC owners will be slipping between the material and spectral realms but a week after their PS-owning friends get hold of copies towards the end of May.



**Avid** SOFTIMAGE® | 3D

**4 Seats £6,750**

**Including 2 days training**

**Avid** tools for storytellers™

**EVIL ZONE**

Coming from Japanese developer Yukes (and published here by Titus), *Evil Zone* (originally known as *Eretzaju*) is a manga-influenced, projectile-based 3D fighter for the PlayStation. Ten combatants fight using a multitude of weapons and outrageous, visually intensive special attacks. Six playing modes are available and combatants can choose to fight in any of the 11 settings offered. Out in June.



**SLAVE ZERO**

FORMAT: PC DEVELOPER: ACCOLADE

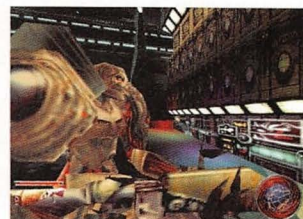
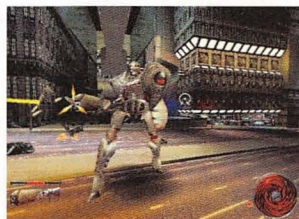
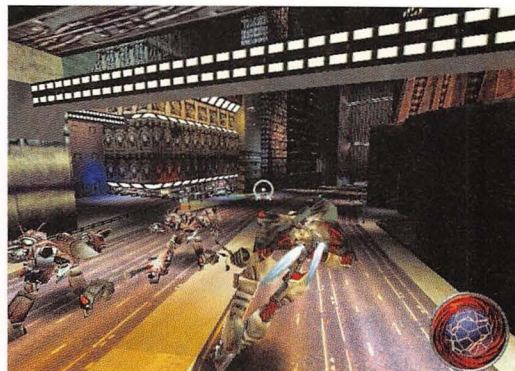

It's astonishing how much difference a month can make. When *Edge* last saw Accolade's offering featuring big robots battling amid a futuristic city, the whole project still looked very much like it did in *E69's* Alphas. These latest shots show a much improved level of detail and more ambitious use of textures. Who knows what another month may bring...

**TA KINGDOMS**

FORMAT: PC DEVELOPER: CAVEDOG



With the next generation of RTS games suffering from slippage, Cavedog is working hard balancing the four different races that will be battling it out in *TA: Kingdoms*. Named Earth, Wind, Fire and Water, each possesses different characteristics related to its element. Another development from the original sees two types of resources to covet – mana and the mysterious margrium.



## ABOMINATION

Combining realtime tactical strategy and a cooperative core, *Abomination* pits a team of bio-hardened marines against the evil Brood. The campaign mode enables four players to complete the singleplayer plot, with the game saved on all participating PCs. Any players can host further games. The more visceral pleasures of competitive and deathmatch modes are also supported.

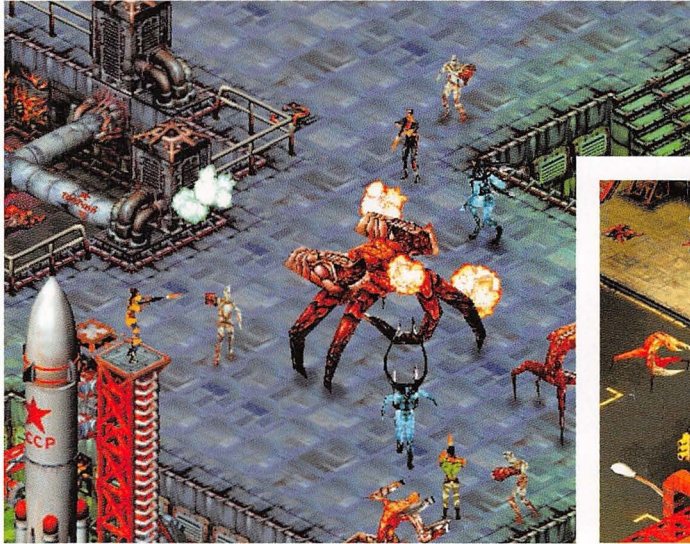

FORMAT: PC DEVELOPER: HOT HOUSE



DARKSTONE

Delphine's stylised RPG continues to blossom as deeper dungeons and monsters are revealed. Although, with 32 levels to battle through, there are bound to be plenty of as-yet-unseen creatures and locations to experience ingame. The automatic quest generator should hopefully boost the replay value as well. While the PC version promises to be stunning, though, squeezing the game into PlayStation-sized morsels would appear to be a thankless task.



**1x SOFTIMAGE® | 3D Base**

**3x SOFTIMAGE® | 3D GT**

Version 3.8 SP1, both IRIX and NT CD's

**2x One Day Training**

**£6,750**

Promotional period- **April, May and June 1999.**

Prices exclude VAT and delivery.

**Contact us now for further details:**

**☎: 0171 538 3800**

**e-mail: [3doffer@aura.co.uk](mailto:3doffer@aura.co.uk)**

**Avid.**

AURA is a registered trademark of AURA Business Systems Ltd.  
All other trademarks are registered trademarks acknowledged.

**AURA**

# RALLY MASTERS

FORMAT: PC/PLAYSTATION/NINTENDO 64 DEVELOPER: DIGITAL ILLUSIONS



You're looking at the first PlayStation screenshots of Sweden-based Digital Illusions' ambitious rally venture. As mentioned in last month's preview, although forced to display the polygonal action at a lower res, the team's technical expertise has ensured PS owners have a version which remains satisfyingly focused on the tracks left by its 3D-accelerated PC cousin.

# V-RALLY CHAMPIONSHIP EDITION 2

FORMAT: PS DEVELOPER: INFOGRADES

As recompense for not being able to bring you as many images of different cars in last month's *V-Rally 2* Prescreen as would have been ideal, this new selection should give you a better idea of the variety of throaty contraptions just itching to be thrown around a bundle of variously surfaced tracks.



## OFFICIAL F1 RACING FORMAT: PC DEV: VIDEO SYSTEM

Having recently acquired the illustrious FIA licence, allowing it to publish Formula One titles featuring real drivers, genuine cars and authentically named circuits, Eidos has swiftly taken advantage of its privileged position by snapping up what is essentially Video System's PC (PS version follows later in the year) interpretation of its very impressive N64 racer. Review in E72.



## KYOKUSHIN KARATE FORMAT: PS DEVELOPER: BANDAI

Some of you may remember *Budokan* on the Mega Drive. But, for those that don't, Yadda's title was one of the very few attempts at producing a realism-influenced beat 'em up focusing on a variety of martial arts. This Bandai effort sets its sights on just one - karate - but the concept of reality-based combat remains as you train your fighter in order to enter world tournaments.



# ENCYCLOPÆDIA BRITANNICA

<b>3+ hours</b> of video and anima- tion. Sound and pic- tures bring knowl- edge to life.	<b>33,000</b> Internet links. Plus 1.4 million hyperlinks between related articles.	<b>2+ hours</b> of audio. The ulti- mate multimedia experience is enhanced with orchestral sound.	<b>13,500</b> photos and illustra- tions. Plus over 1,200 interactive maps.
---	---	--	---

## THE ULTIMATE VISITOR GUIDE TO LIFE ON EARTH



### It's life as we know it

The most comprehensive reference guide to life on earth is now available on Digital Versatile Disk. All 32 bound volumes of Encyclopædia Britannica have been captured on DVD. You'll find 73,000 in-depth features and 13,500 photos and illustrations, brought to life with more than 2 hours of pin-sharp sound, crystal-clear video footage and spectacular animation to enhance the DVD experience. Lightning-quick navigation software and seamless sequencing take you to selected subjects in seconds. And 33,000 related Internet links take your quest for knowledge into another dimension.

In the latest DVD format, Encyclopædia Britannica is light years ahead of the competition. So, get ready to take a spectacular voyage of discovery through every aspect of life as we know it.



Enjoy the ultimate multimedia experience today - Britannica on DVD for just £99 at leading retailers.

Currys WHSmith PCWORLD Virgin MEGASTORES @Jakarta  
Dixons GAME TOYS'R'US HMV electronics boutique

## TOTAL AIR WAR

FORMAT: PC DEVELOPER: DID



Ten dynamic campaigns, over 22,000 targets and 5,000 named cities, realtime tactical mission planning, cooperative multiplayer, improved polygons, true 3D clouds, enhanced realism, a custom air-to-air combat editor, context-sensitive music and a 350-page manual. DID's sequel to the highly acclaimed *F-22 ADF* is a comprehensive beast.

## CROC 2

FORMAT: PLAYSTATION DEVELOPER: ARGONAUT

Argonaut returns with the sequel to its million-selling, kid-friendly, cute crocodile-starring, 3D PlayStation platformer. As previously, things look technically accomplished with a very stable, solid-looking environment, and character design remains as strong as ever – the 19-strong team is certainly making Sony's 32bit machine work hard. It may initially look suspiciously similar to the original, but aspects such as alternative level routes could improve the action significantly.

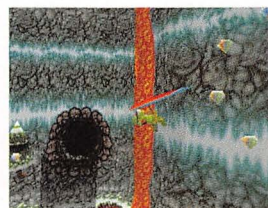
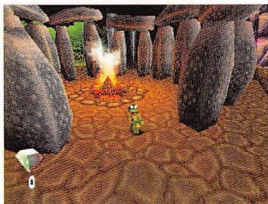



## DESCENT III

FORMAT: PC DEVELOPER: INTERPLAY

Interplay's third instalment in this intriguingly popular series continues its steady progression towards finished status, as these recent shots attest. What they will undoubtedly fail to convey, however, is the fluidity apparent when changing between the game's two 3D engines – one controlling the indoor sections and the other charged with generating the outdoor equivalents.



## EAGLE ONE

FORMAT: PLAYSTATION DEVELOPER: GLASS GHOST

Developed using a 32bit-friendly version of its high-end Icarus engine, Glass Ghost's *Eagle One* is best described as 'True Lies' in videogame form. The gameplay mixes flight-sim physics with arcade action. The plot itself is simple enough, though. With the Hawaiian islands overrun by terrorists, you and your Harrier jump jet must save the world. Bonus levels are unlocked by fancy flying, and the love interest is supplied by a female agent trapped behind enemy lines.

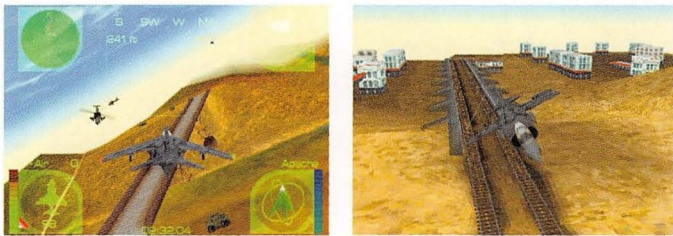

# nails!



## Single & Multi-Player Next Generation Killer

WHERE THE BIG GAME IS



Totally  
Addictive

AVAILABLE ON PC CD-ROM

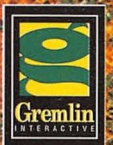

Download the demo from:  
[www.wildmetalcountry.co.uk](http://www.wildmetalcountry.co.uk)

The Wild Metal Country logo is a registered trademark of DMA Design Limited. © 1998 Gremlin Interactive Limited

# GRAN TURISMO 2

In its day, *Gran Turismo* revolutionised the way the world looked at racing games.

While its successor is unlikely to achieve that same feat, it's destined to make quite an entrance



Time restrictions impeded Polyphony from including the range of vehicles it wished for in the original *Gran Turismo*. No such problems this time, though

Few people could have accurately predicted *Gran Turismo*'s phenomenal success. Yes, it's a superlative simulation-influenced racing game, still very much in a class of its own, which redefined what could be achieved within the driving genre as well as making every other car game developer have to work a lot harder in order to get noticed. This alone is a very good thing, since a depressing number of developers have a habit of targeting popular videogaming categories and releasing tired, under-programmed, poorly designed products in the hope that their content will ride the wave and succeed.

But 6.2 million copies worldwide is a staggering amount of black discs, regardless of how high the quality of a title. Indeed, Kazunori Yamauchi, the game's producer, will be the first to tell you how surprised he's been with *GT*'s popularity, particularly as he'd originally developed it mainly for the Japanese market.

A sequel was therefore inevitable. And since **Edge** last visited Polyphony's Tokyo-based premises for an exclusive look at the game some four months ago, a few more details have emerged. The anticipated figure of 400 cars prevails, and while Ferrari and Porsche may have ended up on the cutting-room floor due to licensing restrictions, the selection remains likely to be the most exciting and well-chosen ever to grace a driving game. The emphasis is very much



The game's structure now allows you to decide which category to race your car in – it may then require a certain amount of modifications

on sportscars rather than the supercars usually found in so many racing games, but the selection should cater for all tastes, however demanding.

In addition to the rally, sportscar and GT competition, there is now a drag-racing mode for anyone solely concerned with the acceleration and torque values of their tuned machines. And while *GT2* does not include dragster-type vehicles, US muscle cars will make things a little more authentic should you find that racing down a

Format: **PlayStation**

Publisher: **SCEI**

Developer:

**Polyphony Digital Inc.**

Release: **September**

Origin: **Japan**



New categories of racing may feature second time around, but transforming your car into a fully fledged GT sportscar remains as one of the many options



Expect the already much-lauded dynamics of the original GT to be improved upon; Polyphony is focusing on making them more realistic

quarter-mile stretch of tarmac isn't entirely representative of a Mini Cooper's true abilities. The structure, so superbly implemented in the original, has also been revised and looks as revolutionary as its predecessor. Gone are the different classes, to be replaced with a model closer to reality: after buying your vehicle from the relevant garage, you must decide which

## Polyphony is paying particular attention to the dynamics and the AI to improve the relationship between you and the opponents on track

category of motorsport you wish to compete in. Regardless of your choice, the apposite tune-up options need to be obtained before lining your car up on the grid, so if you feel like rallying your Peugeot 106, it'll need modifying to suit the rugged nature of that particular sport. You're free to purchase any car and enter any category, so long as the model is appropriate for that type of racing. It's little use, for example, trying to modify a tarmac-loving Mercedes CLK to run in mud.

Other changes include around 60 licence tests, but these caused a few headaches in

the original so the team plans to implement a system to cater for all the Ukyo Katayamas out there (although the structure is yet to be decided).

What has been finalised, however, are the tracks. As previously revealed, Rome, Tahiti, Seattle and the Côte d'Azur form part of the 20 circuits offered in GT2, but so does a track set in Colorado's Pikes Peak area and Laguna Seca Raceway in California, one of the premier motorsporting venues in the US (and the only licensed track in the game). According to Yamauchi, the disproportionate number of fictitious courses allows the team to maximise the potential of the graphics engine.

The improvements are more than just cosmetic, of course. Most of the game's mechanics are to be enhanced (for instance, the introduction of limited slip-differentials for the cars is just one parameter for better dynamics), but Polyphony is paying particular attention to the physics and the AI so as to improve the relationship between you and the other opponents on the track.

That should give other racing game developers something to think about.



As it seems to be the only way to get US players interested in racing games, cars do jump this time. But only if it's appropriate



Seattle's streets double as a circuit, here being tested out by a classic '70s-style Datsun 240Z (above)

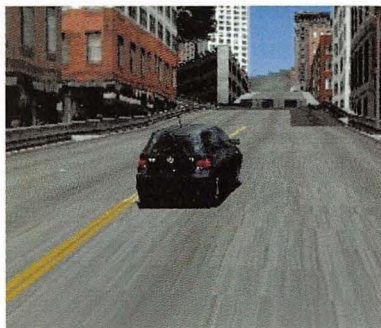

# DEAD OR ALIVE 2

The first incarnation of Tecmo's beat 'em up is remembered as much for the jiggling of female physiques as for fighting prowess. So what new moves can the sequel offer?



The graphical quality of *Dead or Alive 2* made it one of the most striking games on show at TGS. The growth of level size has given the team the opportunity to be inspired by other videogames – witness this 'Zelda-like' waterfall (right)



Producer Tomonobu Itagaki is playing up *DOA2*'s action aspects

With the beat 'em fraternity split into *Street Fighter*, *Tekken* and *Virtua Fighter* factions, it has always been hard for new additions to muscle in. But recent games such as *Power Stone* and *Ehrgeiz* show that innovation is possible. Back in '97, Tecmo added sex to the violence with *Dead or Alive*. Although it possessed ideas that took it beyond *Virtua*

title since September. And, as is becoming standard for high-end arcade titles, its visual opulence is expected to be supported by multiple Naomi architecture.

Presented in video form at TGS, *Dead Or Alive 2* was one of the most striking games on display. "I wanted to return to a more primitive and good-looking concept," laughs producer

**"I wanted to return to a more primitive and good-looking concept, so our basic concept was sex and violence"** Tomonobu Itagaki

Format: Coin-op/Dreamcast

Publisher: Sega

Developer: Tecmo

Release: TBA

Origin: Japan

*Fighter*-clone status, most interest focused on the overly buxom characters. Its infamous 'jiggle' option took breast animation to new levels.

Still, with both the Saturn and PlayStation releases well regarded, few were surprised when Tecmo decided to make a sequel. The 40-strong development team, consisting of veterans of *DOA*, has been working on the

Tomonobu Itagaki, "so our basic concept was sex and violence."

Addressing one of the criticisms of the original, Itagaki-san promises that the finished game will have more characters than most other 3D fighting games. He has also beefed up the plot structure. Driven by realtime cut-scenes, this follows the story of main character Kasumi and

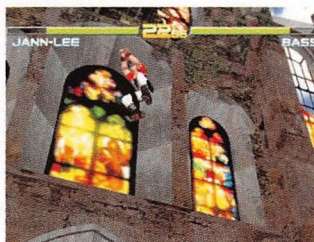
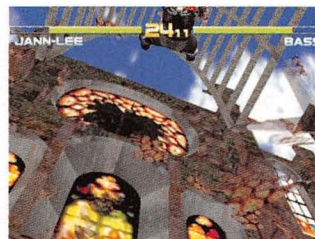

In keeping with the original title, Tecmo has continued to develop the concept of explosive 'danger zones'. This forces players to be aware of positioning within the ring. Each level is now also split into upper and lower stages, providing the opportunity to throw opponents over the edge (top right)

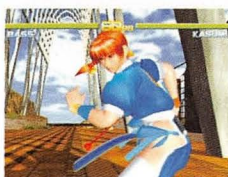

The female form is still a vital part of *Dead Or Alive 2*'s attraction

her sister Ayane. As before, all female fighters are well endowed in the mammary department. "Visually, we have included some sexy animations," Itagaki-san explains ominously. Breasts aside, however, where the original impressed with detailed backgrounds, this has been improved upon. The use of danger zones, in particular, subtly altered the balance of the gameplay compared to the 'ring outs' of *Virtua Fighter*. Instead of causing immediate KOs, danger zones, when triggered, blow fighters into the air. Damage, while major, is not fatal. This forces players to be aware of their position.

"We implemented other systems related to the danger zones," explains Itagaki-san. "We wanted to make the game look more real so we increased the effects and introduced new character animations during the explosions."

Taking the concept of interaction with the scenery one step further, each stage is now split over two levels. Characters can be thrown over the edge as well as suffering danger-zone damage. For some of these, Itagaki-san took inspiration from games other than just beat 'em ups. "I was so impressed by *Zelda* that I included a waterfall stage," he says. Devotees of Link's adventure will notice distinct similarities when *DOA2* characters tumble down the waterfall.

Another of the innovations that the original offered was a three-button control system. Kick and punch was as standard, but instead of the 'block' of *Virtua Fighter*, *DOA* introduced the 'hold' concept to fighting games. This forced players to be more aggressive, allowing a wide range of countering moves rather than a simple defensive approach. "I wanted to keep a three-button system because good playability is very important," says Itagaki-san. The evade option debuted on *Virtua Fighter 3* does not find favour. "A fighting game has to be an offensive type

of game," he states. "*Virtua Fighter 3* is a defence-type of game. Players alternate defence and attack; then position, defence, defence and defence again. *Dead or Alive 2* is offence, offence, offence," he smiles. *DOA2* borrows the tag-team concept from Capcom, enabling players to switch between characters at any point of the battle.

As for weapon-based fighting games such as *Power Stone*, Itagaki-san is yet to be convinced. "It is a difficult genre. They are not becoming hit titles," he argues. Equally forthright about the general drop in popularity of fighting games, he adds: "I believe they were too numerous. People were fed up with the genre." The future is clear, though. "Fighting games will become simpler and more powerful. I believe that we will arrive back at our origin – linear fighting games." E



The four health bars reveal this to be a screenshot from the new tag-team option. Players can switch between their fighters at any point

# JUMP RUNNER

Glass Ghost's roots may be firmly planted in flight sims, but this space-based combat and trading game is aiming to prove that a developer can change its spots



Although combat is exciting, players will need to trade cargo to upgrade weaponry

The *Jump Runner* universe is home to a varied selection of different gangs and empires. Ethan Fall comes under attack from a capital ship and two diamond-shaped fighters belonging to the Brethren, the galaxy's dominant warlords (above)

If a week is a long time in politics, 12 months should be a lifetime for a developer in flux. It is, however, a situation **Ian Baverstock**, co-founder of flight sim developer Simis, has become all too familiar with since negotiating a management buyback from Eidos last year. "We went back to being independent in March '98. It seems like ages ago," he recalls with a wry smile. But that was just the beginning of the story. Clearly, if Simis was to survive on its own, it would have to reconsider its core philosophy. As many developers find to their peril, relying on a single style of game can leave a company financially vulnerable. For the newly independent Simis something new was needed.

A year on and two studios now exist where there was once one. Simis continues as before, specialising in PC-based sims – under the same roof, but a world apart is Glass Ghost. This is the studio Baverstock and co-director Jonathan Newth believe will take the company to the next level. And, specifically, the game they hope will get them there is *Jump Runner*, a space-based combat and trading game. It's no surprise then

that *Jump Runner* is described to **Edge** in grand terms. Obvious comparisons such as *Elite* and *Privateer* are trumped by *Grand Theft Auto*, *Dungeon Keeper* and *Final Fantasy*. Perhaps the closest comparison, though, will be *Freelancer*, Chris Roberts' long-term project. With this in mind, it seems somehow appropriate that *Jump Runner*'s lead designer is also called Chris Roberts. Maybe the folks over at Digital Anvil (see E70) should start paying attention...

Set hundreds of years into the future, the eponymous jump runner, Ethan Fall, is a small-

Format: PC/Dreamcast

Publisher: TBA

Developer: Glass Ghost

Release: December

Origin: UK

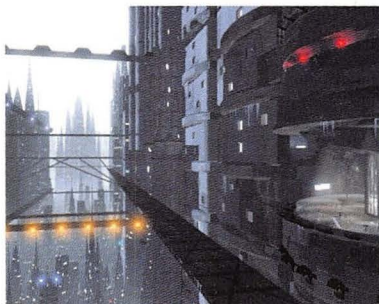

Missions and intelligence can be gathered from the 120 locations scattered throughout the universe

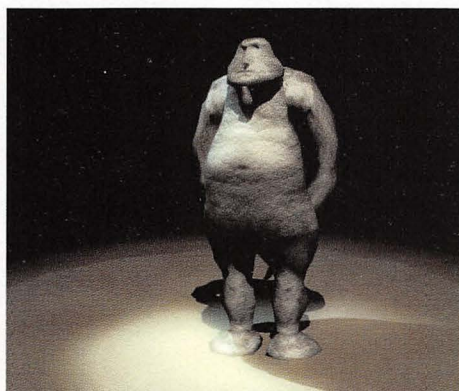

Essentially, the game mixes the adrenaline-rush of space combat with the capitalism of smuggling. The storyline, which follows the exploits of jump runner Ethan Fall, is driven by high levels of characterisation

time smuggler. The game opens with him accepting a mission to carry a mysterious package. Before he can learn its destination, however, his contact is assassinated. He flees to a ship and escapes. A cut-scene then shows six bounty hunters being briefed to recover the package. Acting as end-of-level bosses, they continue to track Ethan throughout the game.

have ripped off some valuable cargo from one gang, you shouldn't get into too much trouble with their arch rivals.

Another important issue has been accessibility. As **James Brooksby**, project director, explains, "Jump Runner is for Dreamcast and PC, so it has to be designed so that anybody can pick it up." With this in mind, the team has introduced high

## Players travel around sprawling galaxies, accepting bread-and-butter missions to build up resources

This is typical of the way the plot is structured. Players travel around sprawling galaxies, accepting bread-and-butter missions to build up resources. Unlike *Privateer*, you can own more than one ship and swap weapons. Progress is strictly controlled by plot missions, however, and clues to the significance of the mysterious package are slowly uncovered *en route*.

One of the underlying features that links the freeform and the scripted elements of the game is the notoriety index. The more audacious Ethan's criminal behaviour, the more aware the authorities become of him. When the index reaches a certain level, he has to join one of the three criminal gangs to survive, the objective being to rise through the ranks. And an updated hate list informs you of the aggressiveness of the various gangs that Ethan encounters.

Each level is determined by the success or failure of previous missions. For example, if you

levels of characterisation. "As a player, you need to feel you are somebody," he comments. "You need to feel that the reason a character looks like he does is because he's a gang member." All the trading is driven by interacting with characters animated over prerendered backgrounds. "We wanted to get away from mission briefings and introduce the story elements of something like *Final Fantasy*," Brooksby continues.

Having been in development since August, *Jump Runner* may only be halfway complete, but a small-scale multiplayer universe has already been successfully tested. The final version will support a persistent Internet environment for PC and, potentially, Dreamcast users as well. But for *Baverstock*, *Jump Runner* is more than just another game: "Glass Ghost is focused on games, and *Jump Runner* is our premier game. It will be the one to show off what we can do."



This sleek fighter (top) was one of the first ships designed. Bulky carriers and capital ships will also feature

# TOKYO HIGHWAY BATTLE

Not all driving games are designed to be realistic. Genki's latest is all about one skill – overtaking – as rival racers line up to do battle lap after gruelling lap

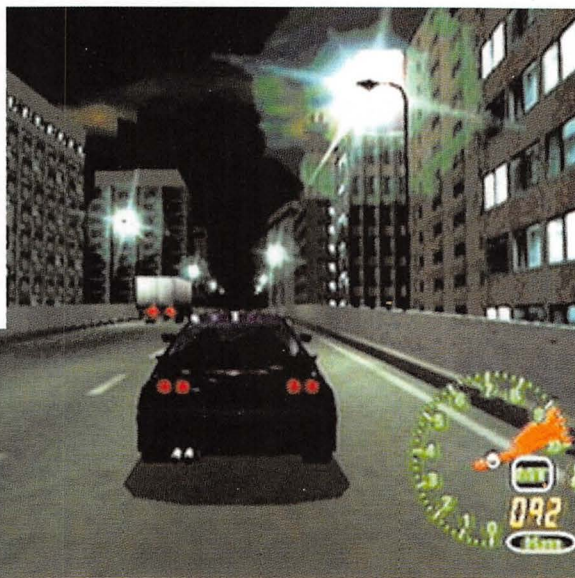

The ebb and flow of each battle is measured by 'spirit' gauges. Every battle won results in prize money to upgrade cars or individual parts

Sega may be struggling in the west, but the amount of Japanese thirdparty Dreamcast support remains one of its trump cards. And while big names such as Capcom and Namco grab much of the attention, smaller companies are also aggressively positioning themselves in this new market. One of the early winners of such manoeuvring has been Genki. To date, its most impressive exploit is the *Virtua Fighter 3tb* port. This remains one of the better Dreamcast games, despite being a launch title. Sega was obviously pleased with the result, too, as it has handed Genki the *Virtua Striker 2* conversion.

More importantly for Genki's own reputation is the news it is working on a Dreamcast port of its popular (in Japan) PlayStation series *Shutokou Battle* (*Shutokou* is a toll motorway into Tokyo, hence the English title *Tokyo Highway Battle*). Although it looks and handles like a regular racing game, *Highway Battle* belongs to the more

Located somewhere between a beat 'em up and realistic racing game, *Tokyo Highway Battle* requires some ballsy overtaking manoeuvres to take the title

specialised racing-battle category. Instead of the objective being a realistic racing experience, this game revolves around one skill – overtaking.

This philosophy is evident throughout. To start the game proper, players need to find a rival car to race or 'battle'. The state of each battle is monitored by a 'spirit point' gauge. This rises and falls depending on the distance between the vehicles, but Genki promises that other driving parameters will affect the gauge. Overtaking completes each individual battle and the game ends after all the cars have been defeated. The Quest mode, for example, features more than 150 different rival cars.

Other game modes include the *Gran Turismo*-inspired Quick Race mode. This has a time attack-style environment in which players race the customised cars they have built and tuned. Winning battles generates extra money to buy new cars and parts. Twenty car models will be available, each with upgradable parts such as tyres and spoilers.

Far from complete, there was a version of *Tokyo Highway Battle* running at the Tokyo Game Show. There is obviously a lot of work still to be done, particularly on the background detailing. And while it looked good, game speed was slow. Hopefully, Genki's prior Dreamcast experience will help speed up the process. 



Twenty cars will be available in the game, but Genki remains tight-lipped about which specific manufacturers and models will feature

Format: Dreamcast

Publisher: Sega

Developer: Genki

Release: May

Origin: Japan



# BRAVEHEART

While Hollywood captured big box-office success with its 'romantic' representation of Scottish history, Red Lemon has secured the license for its own take on tartan terror



Red Lemon is trying to appeal to both hardcore strategy gamers and the mainstream by pitching *Braveheart's* battles in 3D



Controlled through a point-and-click system, campaigns can be waged against your enemies with warriors, battering rams and siege catapults

Travelling north from sunny Bath to the wilds of downtown Glasgow, **Edge** gradually becomes aware that Mel Gibson's 'patriotic' Scots epic, *Braveheart*, is taken rather seriously in the land of tartan. Arriving at Red Lemon's decidedly untraditional office (complete with fibreglass 'think-tanks' in the lobby), it soon becomes clear that the company is more than a little proud of its newly adapted license (courtesy of Eidos' marketing department).

Originally titled *Tartan Army*, *Braveheart* is a curious collision of traditional 2D resource management and crowd-pleasing 3D battles. Assuming the role of leader for one of 16 Scottish clans, including that of William Wallace (star of Gibson's film), you must guide your people – and eventually your country – to freedom.

Dragging the game's co-designer **Andy Findlay** (also a Red Lemon co-founder) into the nearest think-tank, **Edge** sought to uncover *Braveheart's* intricacies. "We wanted to have a game which has depth," explains Findlay, "and gives the player some kind of longterm satisfaction, but also to make it mainstream."

Certainly, the 'Braveheart' license guarantees the game a mass market appeal, and adapting *Tartan Army* wasn't a problem, says Findlay. "It was quite easy, to be honest. The game ran pretty much along the lines of the movie anyway. The characters from the film actually represented the leader-type characters we'd already designed, so it was fairly painless to slot in Wallace."

Although you're confronted by 12 option screens with which to govern your people, novice gamers can opt for a much-simplified system. Overview screens embrace everything from the inter-relationships of clans, to construction and weapon manufacturing. "We've approached it with this kind of automated management system," illustrates Findlay. "You can click on auto and just aim it towards the three points of the triangle – military, people, or trade."

With its 3D battles (complete with all the required graphical trickery), adaptive resource management system, and powerfully emotive license, Red Lemon's *Braveheart* is an interesting endeavour. If nothing else, Findlay and clan owe it to Scotland to succeed.

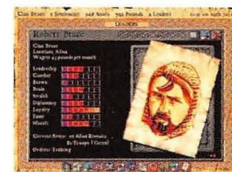

You're given the option of either controlling the game's features right down to the finest detail, or simply setting the system to automatic

Format: PC

Publisher: Eidos

Developer: Red Lemon

Release: June

Origin: UK



# SILENT BOMBER

A simple 'pick up and play' game, Bandai's latest thirdperson shooter is a return to core values for PlayStation owners: simply keep running, pick out those targets and get bombing



One of the most telling features of *Silent Bomber* is the scale of the end-of-level bosses. The gravity liquid power-up (above) proves highly effective

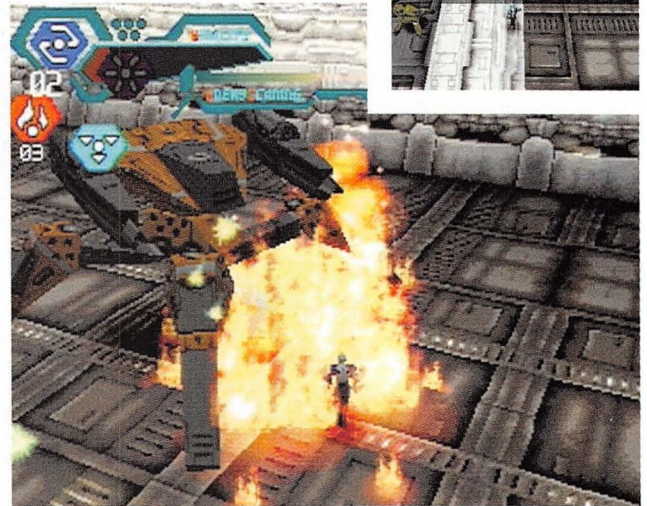
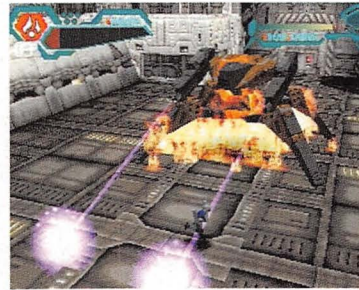

A three-quarter view is just one of the factors that makes the game so easy and enjoyable to play. Frantic speed and intuitive controls are others

One of the surprise hits of the Tokyo Game Show, Bandai's *Silent Bomber* could be a breath of fresh air for PlayStation enthusiasts. With many games becoming over-sophisticated, the thirdperson shooter is a return to the days of simple gameplay. Based around mechanical characters such as the Gundam anime concept Bandai specialises in, *Silent Bomber* is comparable to Konami's old school *Contra* series. Thankfully, though, it is far superior to the last two PlayStation versions of that title.

The most important aspect of the game is the way its control style promotes the overall pace. Movement is controlled via the analogue stick, while the X button triggers jumping. But it is the weapon control that really impresses. The square button operates the default bomb option. This activates a visible blue 'cone' which locks on to any enemies in range. Once locked on, up to two bombs can be thrown from distance.



Each level is completed by the destruction of defined targets. Big laser cannons are just one example



Other offensive weapon pick-ups include napalm, paralysis liquid (which knocks out electrical units for a period of time), and the strangely named gravity liquid. These are cycled using the L1 shoulder button but cannot be thrown and must be placed next to targets.

Destroying targets, ranging from generators to mighty space cannons, completes each level. Of course, all are well defended by missile launchers, robot guards and force fields. And if the colourful prerendered scenery is reminiscent of the glory days of coin-ops, the quality of the bosses confirms the charms of *Silent Bomber*.

With several months development ahead, it will be interesting to see how the game evolves. Following its TGS success, it could become a high-profile title for Bandai. The only criticism at this stage concerns the ease of play and some clumsy camera angles. But when a game has the potential to be as enjoyable as *Silent Bomber*, such gripes might be overcome.

Format: PlayStation

Publisher: Bandai

Developer: In-house

Release: TBA

Origin: Japan



JENNIFER JASON LEIGH JUDE LAW IAN HOLM DON McKELLAR CALLUM KEITH RENNIE  
SARAH POLLEY with CHRISTOPHER ECCLESTON and WILLEM DAFOE as GAS

PLAY IT.  
LIVE IT.  
KILL FOR IT.



“★★★★★  
FILM OF THE MONTH”  
Ben Thompson - GQ

“A RAZOR SHARP  
SCI-FI THRILLER”  
Baz Bamigboye - DAILY MAIL

A Robert Lantos Production  
A David Cronenberg Film

# existenz

15

ANCE ATLANTIS and SERENDIPITY POINT FILMS present in association with NATURAL NYLON ENTERTAINMENT a ROBERT LANTOS production a DAVID CRONENBERG film JENNIFER JASON LEIGH JUDE LAW "existenz" IAN HOLM DON McKELLAR CALLUM KEITH RENNIE SARAH POLLEY  
ROBERT A. SILVERMAN with CHRISTOPHER ECCLESTON and WILLEM DAFOE as Gas Casting by DEIRDRE BOWEN C.D.C. Associate Producer SANDRA TUCKER Co-Producer MICHAEL MacDONALD Co-Producers DALMON BRYANT BRADLEY ADAMS Costume Designer DENISE CRONENBERG  
and Special Effects Supervisor JIM ISAAC Music HOWARD SHORE Editor RONALD SANDERS Production Designer CAROL SPIER Director of Photography PETER SUSCHITZKY Produced by ROBERT LANTOS ANDRAS HAMORI DAVID CRONENBERG Written and Directed by DAVID CRONENBERG  
Produced with the participation of Telefilm Canada Canadian Television Fund Created by the Government of Canada and the Canadian Cable Industry  
CFL - License Fee Program The Canadian Film or Video Production Tax Credit The Movie Network and the Harold Greenberg Fund / Le Fonds Harold Greenberg  
A Canada - United Kingdom Co-Production

serendipity TMN THE MOVIE NETWORK RCA VICTOR

[www.existenz.com](http://www.existenz.com)

ALLIANCE ATLANTIS

AT CINEMAS ACROSS THE COUNTRY FROM APRIL 30

# Omikron: The Nomad Soul

Edge Eurostars across the Channel to see Quantic Dream's recent work on its ambitious parallel universe, and discovers that the world of Phaenon really is your oyster

In *Omikron*, sliders (personal computerised vehicles) know exactly where they're supposed to go after you've supplied them with the required destination. Which is more than can be said for Edge's taxi, which has spent the last half-hour looking for the address of Parisian developer Quantic Dream. And despite assurances to the contrary, Edge is becoming increasingly convinced that the driver is going round in circles, a theory somewhat supported by the fact that France's capital can't possibly have three Eiffel Towers...

When the address is supposedly found, things don't look promising. Faced with a modern residential block, Edge suspects the taxi driver may have strategically bailed out after the fare reached a hefty amount, abandoning what he assumed were odd tourists in one of Paris' labyrinthine suburbs. For a few seconds this seems an entirely plausible explanation, but a close inspection of the building's intercom system reveals a familiar tenant. According to the list of names, Quantic Dream lives in an apartment on the first floor. In fact, it occupies two spacious

Format: PlayStation/PC  
(PC version shown)

Publisher: Eidos

Developer: Quantic Dream

Release: Summer

Origin: France



The complex storyline is refined enough to handle more mature themes (above) without casting the usual exploitative, sordid overtones



residences, with the majority of its 35-odd employees using a plethora of rooms. On the landing, a full-size Babyfoot table (an activity sadly much under-practised in the UK) greets visitors – and requires pulling out into the corridor whenever the urge proves too strong. **Edge** wouldn't go so far as to call the conditions cramped, rather cosy. But if Quantic Dream plans to continue growing, it better start looking for another floor...

**Never-ending story**

Having somehow resisted the lure of an afternoon of Babyfoot, **Edge** settles down with **David Cage**, head of Quantic Dream as well as creator and designer of *Omikron*. Veteran readers may remember the game's original appearance in **Edge** (see **E47**) nearly two years ago, and while the advances in 3D PC technology have allowed the team to radically improve the cosmetic side of the experience, the plot remains the same. "There's no big change in the scenario," explains Cage. "We spent more than a year just writing the story so we don't want to change it now."

**Edge** won't spoil the game by divulging revelatory plot elements, but suffice it to say that as you start the game you have little idea of who you are exactly, and what tasks await you. Having 'arrived' as police officer Kay'I in *Omikron*, one of several cities on Phaenon (a planet in a parallel universe), your only instruction is

to find your apartment. You embark on a journey that not only takes you across Phaenon's contrasting environments but also delivers many surprises. It may be more Roddenberry than Asimov, but *Omikron's* narrative is still better than the majority of games currently on the market and, as such, is very welcome.

The plot is not the only aspect differentiating *Omikron* from the rest of the field, however. "There are several reasons for that," states Cage. "The first is that it's entirely in realtime 3D, and it's a

**It may be more Roddenberry than Asimov, but *Omikron's* narrative is still better than the majority of games currently on the market and, as such, is very welcome**

truly huge environment – it's probably going to be *the* biggest realtime 3D game. We have four different cities, and in these you have passers-by, vehicles, and you can enter any building at any time... we've worked hard on having a real city – with restaurants, apartments, shops, cars,



Your quest in *Omikron* will see you travelling to Phaenon's four cities as well as several outdoor locations. The visual style is well integrated throughout

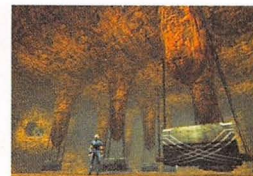

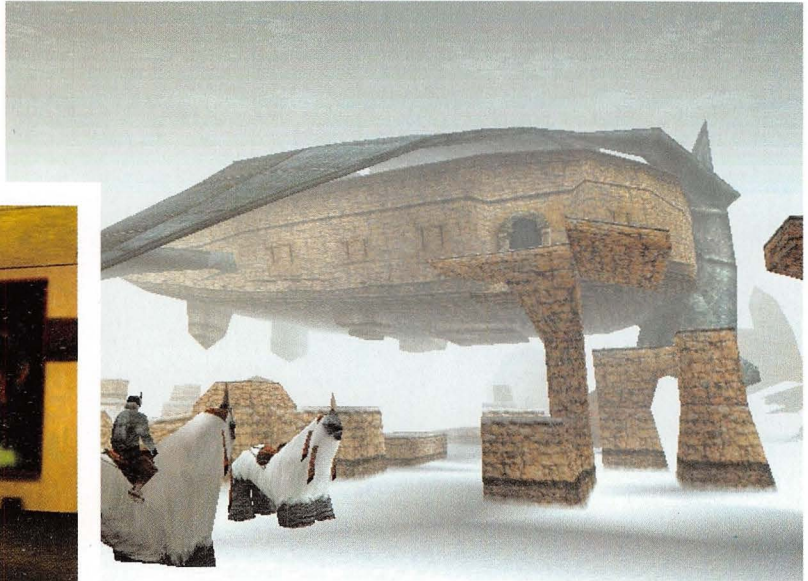

Quantic Dream is particularly proud of its inclusion of realtime facial motion capture for the four hours of dialogue shared among the game's characters

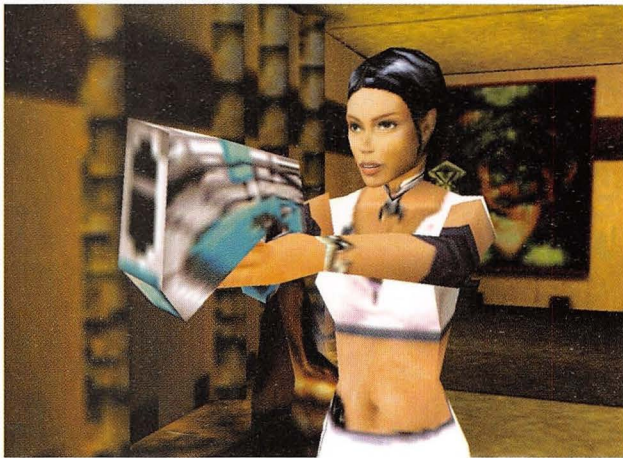

parks, a police station and a red light district. It's been a huge process just to make sure that behind each door there's something there. It's not just a setting, it's a real building with something inside – people living there, for example."

There's more, of course. "The second reason is that we're giving the player complete freedom," Cage continues. "Not only can you walk around, but you can talk to people, use objects, guns, fight with your bare hands, use vehicles and magic spells. There are many different types of gameplay, and I'd say that in a certain way

Shiny). Cage explains: "The soul of the player is within a body. Once the body dies the soul is reincarnated into the body of the first person who touches the corpse. At the moment we have more than 30 bodies you can reincarnate during the game and each has different skills and characteristics – so you can be a very sexy girl or you can be a tough guy, for example."

**Reincarnation spell**

The concept has evolved somewhat since *Edge* last saw the game. Cage explains, "Our initial idea was that when you died

you changed your body, but we thought that it was so much fun to have this ability that we've decided to give the player more opportunity to do that." So now, quite early in the game you find a reincarnation spell. And as you explore your surroundings and meet other characters, you can decide to take over their body and continue your quest within this new frame, provided you have enough points to perform the spell. This opens up entirely new gameplay opportunities and these haven't passed Quantic Dream by. "At some points in the story you need to use this reincarnation

**"We have more than 30 bodies you can reincarnate during the game and each has different skills and characteristics – so you can be a very sexy girl or a tough guy"**



Citing *Zelda* as one of the main inspirations, the team has paid special attention to the 3D camera, with effective consequences

each one is a game. The last thing we want to do is to have cheap games – cheap arcade sections within an adventure game – it's been done before. We want to have real arcade sections within a real adventure game – that's our biggest challenge. So we spend a lot of time balancing elements, trying to find the fun in the arcade parts."

Naturally, there's a third reason, possibly the most revolutionary of the lot. One of the core concepts of the game is the process of virtual reincarnation. Yes, *Messiah* is promising a similar notion but, in fairness, *Omikron* was doing it first (at least, Quantic Dream announced it before

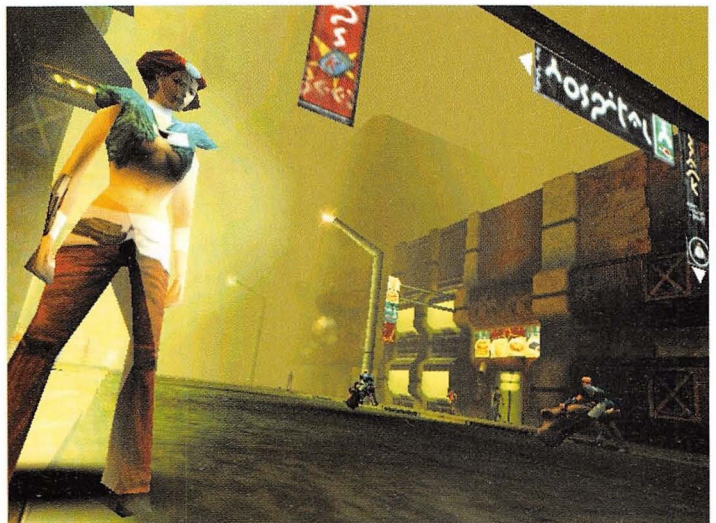

Although not shown, the PS version naturally suffers from lower resolution (despite being in 'hi-res'), fewer civilians and a shorter fogging distance

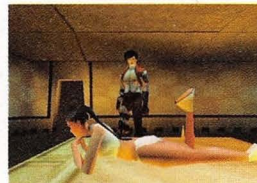
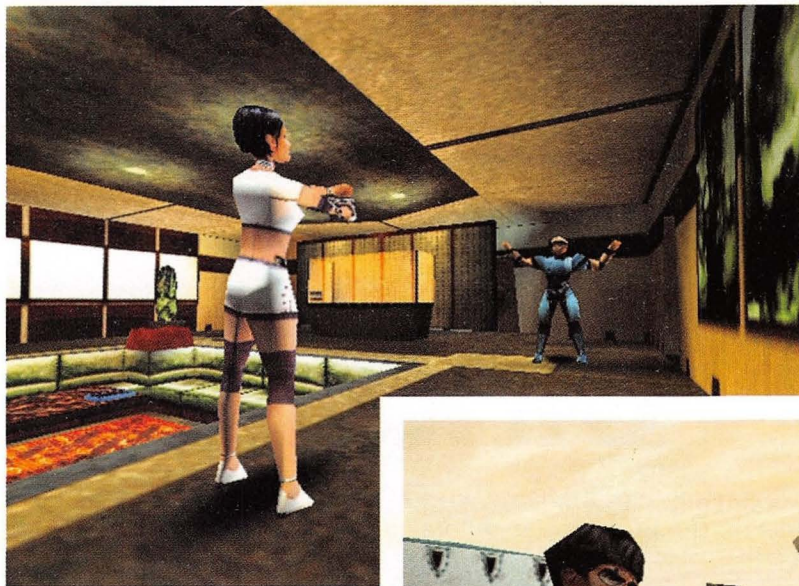

**A limited inventory system allows you to carry up to 20 items with you at all times**

spell to do something specific," says Cage. "For example, when you're in the library only a scientist can access a secret level so the only way to get to this level is to take over the scientist's body." There are less linear benefits as well: "Later on you need to interrogate someone – there are several ways, but the best means of getting information from him is to incarnate a sexy girl because you have more attributes to persuade him with," grins Cage. While this offers huge potential for the player, it does cause a few design headaches. "Your actions will have consequences, so if you do something good or bad your actions will catch up with you," explains Cage. "That's a big challenge for the storyline writing, because you need to think about what happens whatever the player does."

**The Doom view**

Another major alteration affects the shooting action sequences. When Cage last spoke to **Edge** (at ECTS) he may have sworn that **Quantic Dream** would never do a firstperson game due to his propensity for feeling the effects of motion sickness, but he must have found a cure as said sequences are now played in **Doom**-style view. The controls are **Doom**-esque, too (totally on keys), as the view runs along the x-axis.

Nevertheless, **Quantic Dream** is understandably content with what it has achieved so far. The city does indeed exude a real-life feel and there are



**In order to avoid players getting lost in Omikron's expansive realm, a stream of short-term goals make sure you always know what to do next**

countless classy, cinematic touches. Cage attributes this to having the right utensils for the job. "We've spent a lot of time over the last two years working on tools because one of our concepts was that the gameplay must be in the hands of the designer and not of the programmers," he says. "And we didn't want them using up all their time just making small changes, so we've developed tools that allow game designers to change what we want to change. We're particularly proud of our **IAM** (Intelligent Adventure Manager), a scripting tool for all the adventure elements in the game. It's quite important because the final result of the game depends a lot on how the tools are working and how the whole process is done."

The musical aspect hasn't been neglected either. **Eidos** has signed a world-renowned musician, although **Edge** is forbidden to reveal his identity. "I was a musician for ten years before making games, and the last thing I wanted in my first game was to have cheap techno

music," proclaims Cage. "As **Omikron** takes place in a parallel dimension, we wanted to have music from a parallel dimension. We wanted someone ready to be really involved, and we've been incredibly surprised to see that someone as famous as this could be so crazy about the game." So impressed was this musician, in fact, that he offered to do an entire concept album based on the story. He will also play a role in the game. "He'll have concerts in bars, so you'll get a flyer with the address and you can take your slider, go to the bar and see the concert," enthuses Cage. "If you like the song you can go into a shop, buy the record and then go home and listen to it."

Yes, it is an ambitious project. "Our goal at **Quantic Dream** is to develop things that haven't been done before – we just hope to be successful this way," says Cage. If achieved, it should seriously put **Quantic Dream** on the map. And that should at least make life easier for Parisian taxi drivers.

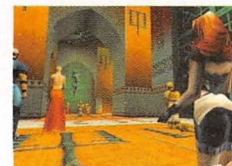

**Quantic Dream's main aim is to convey a genuine sense of life in all of the game's many locations. As such, its inhabitants wander the streets, shop, drink in bars, eat in restaurants and sleep in their flats**



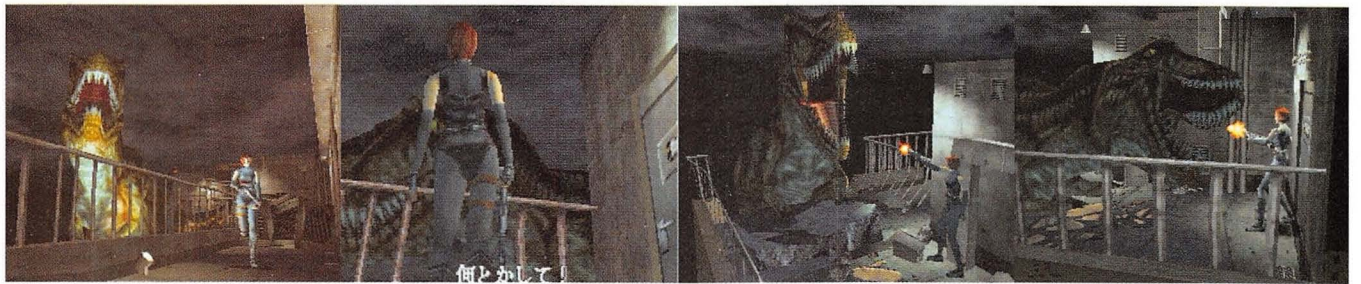

# DinoCrisis

Having already set the console gaming world aflame with his tales of the undead walking the earth, the producer of the *Resident Evil* series is scaling up...

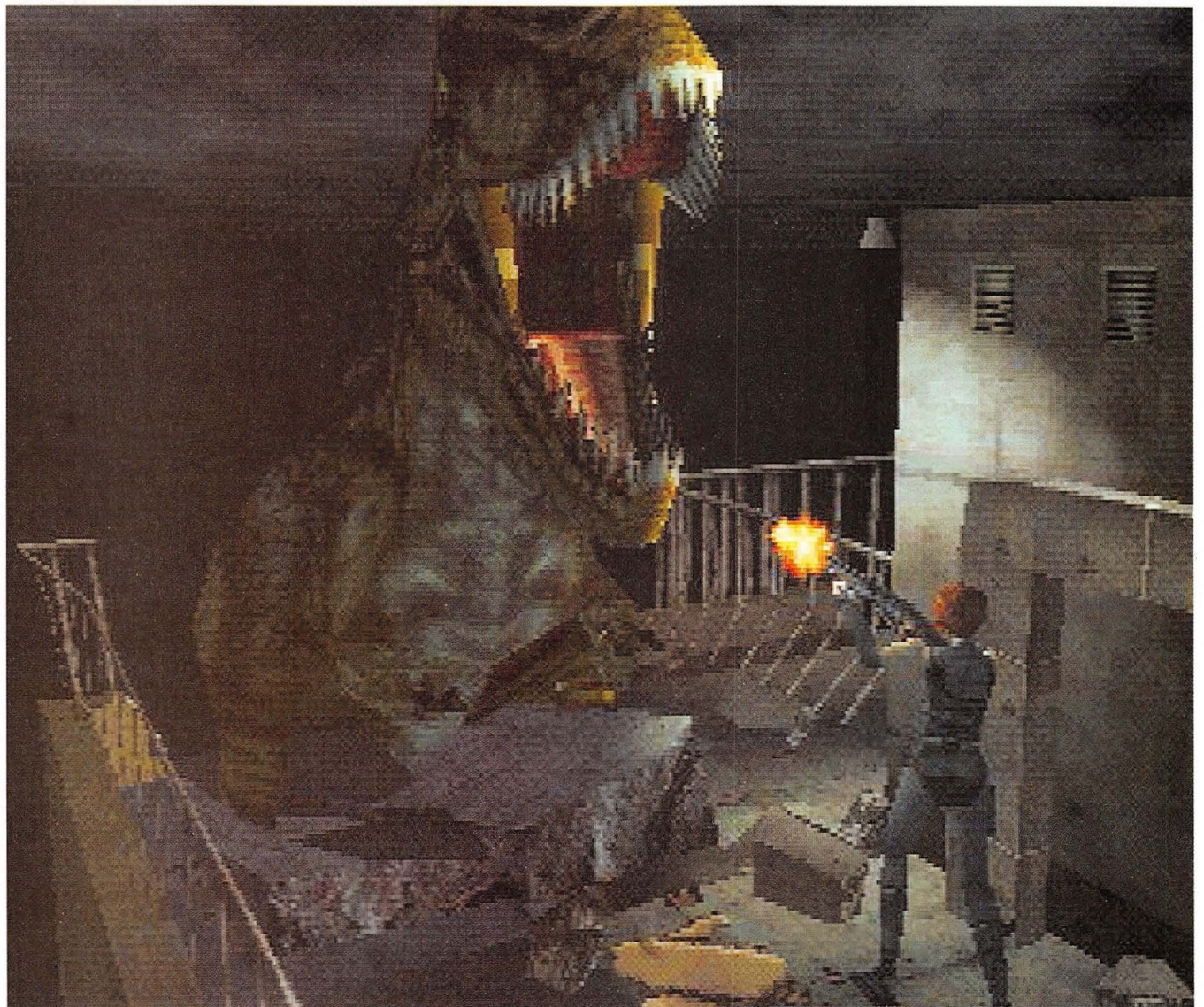



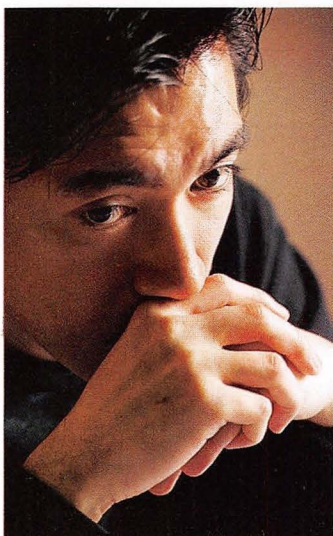

**Shinji Mikami, the man behind the *Resident Evil* series, takes a new, yet in some respects very familiar, trip down the horror game avenue**

**A**s the Tokyo Game Show throbs with activity across three halls of the Makuhari Messe convention centre, **Edge** has retired to the more laid-back environment of Capcom's business suite upstairs. Ensnared within the safety of this room, furnished with six or seven tables around which Japanese industry types suck on cigarettes, Capcom delegates are willing to demonstrate *Dino Crisis*, the pseudo-sequel to the *Resident Evil* series, having offered only glimpses of it via spooling video in the show proper.

**Shinji Mikami**, producer of this new title and the previous *Res Evil* games, seems almost reluctant to be here, as if meeting the press isn't really his bag. After **Edge**'s cameraman has the necessary set up work out of the way, though, Mikami-san gets the opportunity to pick up a joystick and demonstrate his latest work, and he suddenly seems to brighten up.

"I love dinosaurs because they're big, strong, really violent, and really fearsome-looking," he enthuses as he fiddles with a test version of his latest project.

### Biting wit

Having moved away from the fantastical realms of the undead in the *Resident Evil* series, Mikami-san and his team made a conscious decision to produce something more real with *Dino Crisis* – despite these new 'real' elements having not existed for millions of years.

"Producing the dinosaur animation was interesting because we don't know



**Many of the enemies faced by the player will appear on a Raptor-esque scale, while others will make a rather more significant impact (main). Whatever the case, pure, old-fashioned gunplay should prove a suitable cure**

for sure how they moved in real life," says Mikami-san. "So I had to use my imagination. We started out with drawings, which we scanned, and then used animation tools to see how we could make the dinosaurs move. As well as our imagination, though, we looked at the movement of many real animals. Have you seen the dinosaurs biting the player yet?"

With this, Mikami-san flips through various debug menu options to bring up a scene depicting a stand-off between the player's character, a female special agent, and a Raptor-esque adversary. Playing straight into the dinosaur's terrifying claws, he might as well lie the character down on an oversized dinner plate and cover her with gravy. The dinosaur wastes

**"In the *Resident Evil* series the zombies made you feel fear slowly, but in *Dino Crisis* the enemies are a lot quicker and more intelligent... they can even open doors"**

no time chowing down, hoisting her into its maw and thrashing her about. "With things like this, we actually referred to how crocodiles and dogs behave, and looked at their biting action," says Mikami-san. It's certainly an effective – and unflinching – approach.

### Same old story

In storyline terms, like the *Resident Evil* games, *Dino Crisis* is as hackneyed as they come. A scientist, who was believed dead

Format: **PlayStation**

Publisher: **Capcom**

Developer: **In-house**

Release: **TBA**

Origin: **Japan**



中は頼んだ

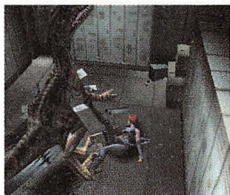

Four main characters will appear throughout the game, and interaction with them will be crucial (top). Three other characters will also appear, but their demise will be more or less imminent



Blasting dinosaurs at close range brings to mind the zombie-killing sprees of the *Res Evil* series, but *Dino Crisis* promises to be a much less pedestrian experience



とにかく今は任務を優先させるしかないわ



A new twist comes into play when you're attacked unwittingly – it's possible to actually drop your weapon, leaving you stranded

**Giving the enemies an extra helping hand in their pursuit of the player is the way *Dino Crisis* handles injuries. The dinosaurs can smell blood and will track them down**

following an ill-conceived, world-changing experiment, has recently been discovered working at a military research centre on a small island. You assume the role of a special agent and infiltrate the base with a special ops team. It's not long before the results of the scientist's experiments

and they're more intelligent. As soon as you leave a room you cannot say that the danger has gone, because the dinosaurs can even open doors. And they will chase you. Unlike *Resident Evil*, this game is more a matter of constant fright."

Giving the enemies an extra helping hand in their pursuit of the player is the way *Dino Crisis* handles injuries, as Mikami-san explains: "When you get bitten by a dinosaur, you're going to bleed. And you have to look at this problem in two steps – it's not just a question of picking up a medikit. First, you have to stop the bleeding, then you can heal. While you're bleeding, though, your blood will stain the floor, and the dinosaurs can smell this blood and will use it to track you down."

**Browned off**

Technically, *Dino Crisis* uses an original 3D engine not entirely unlike that of *Metal Gear Solid*, if not as immediately impressive at this point in the title's development. The game also seems to have an over-abundance of the colour brown, resulting in some unmemorable scenery, although the animation at least matches up to the exceptional standards set with the *Res Evil* series.

Mikami-san opted for a realtime engine because he "wanted to challenge

the theories of representing backgrounds." He won't be drawn on whether or not he believes realtime 3D will make *Dino Crisis* feel even closer to horror movies than the *Resident Evil* games were, but, by means of a section of the game which shows the action directly from a rapidly attacking dinosaur's point of view as it bounds across the tops of packing crates, he reveals the sort of cinematic device that will be used to keep the tension levels crackling – the sort that simply would not have been possible using prerendered scenery.

As *Edge* is given a guided tour of the game's locales it's clear that, although *Dino Crisis* is set on an open island, most of the action will take place indoors – or at least in confined spaces. "It's the same concept as the *Resident Evil* series," reveals Mikami-san. "In order to actually build the scariness I think it's best to have enclosed environments."

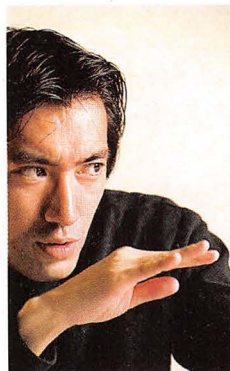

Photography: Hiroki Izumi

Looking towards the potential of new hardware? Oh yes

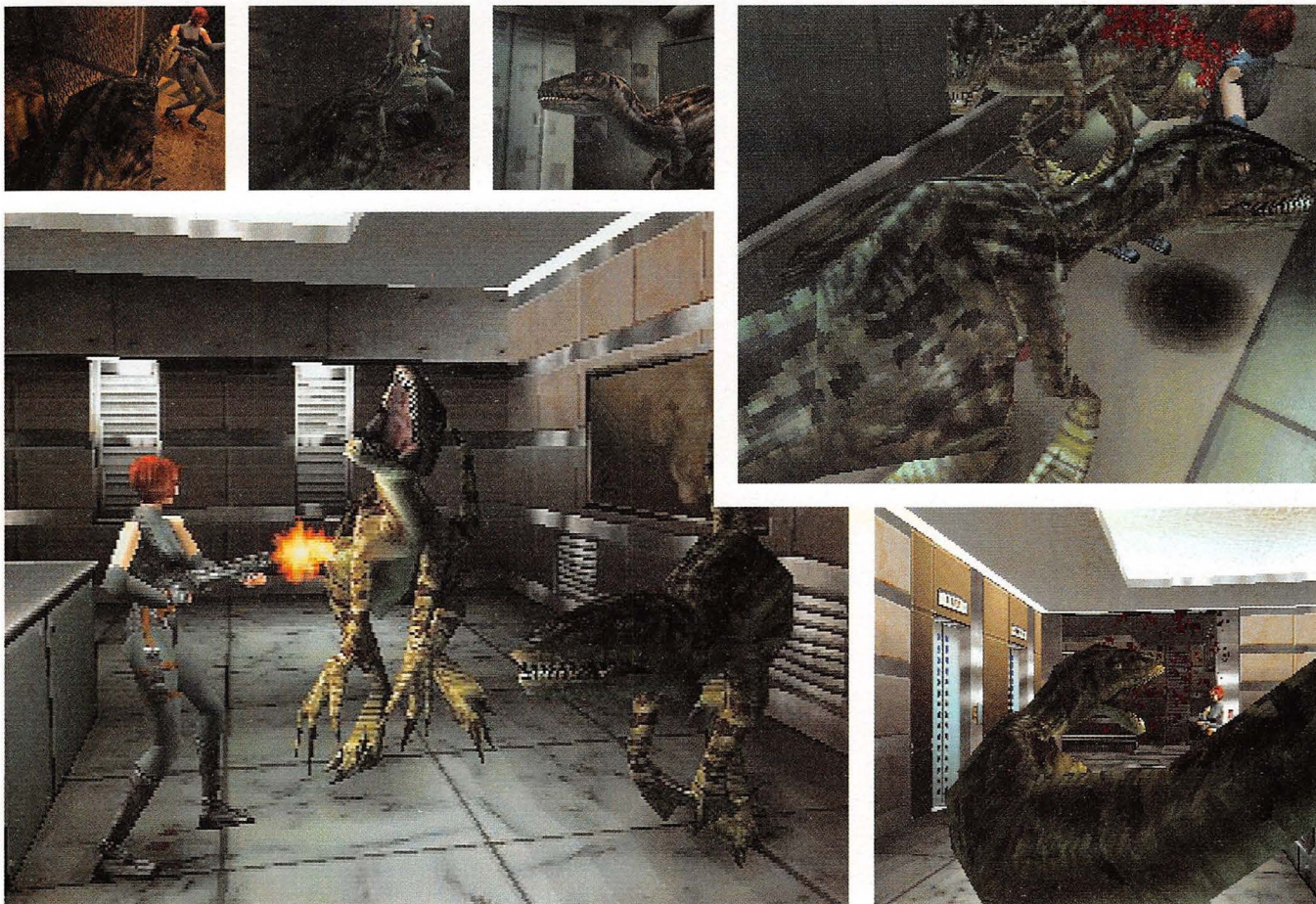

Capcom claims that the playing area of *Dino Crisis* will be similar to that of the *Resident Evil* games. While there's a degree of outdoors-based action (one memorable scene features a character being hoisted aloft by a pterodactyl), the bulk of the gameplay will occur within claustrophobic environments

### Powerful weapons

Typically, the finished game will offer a range of increasingly powerful weaponry, but in its efforts to bring *Dino Crisis* closer to reality Capcom has refined the simple up/level/down gun-aiming mechanics of the *Evil* series. It's now possible to cradle a shotgun at waist level, bank-robber style, for quick, if rather scattershot, cartridge unloading, or hold it with butt to shoulder, sniper style, to maximise accuracy at the cost of speed.

As far as other series-defining enhancements go, it seems that Mikami-san has had to actually scale down some of his ambitions for the title. "Well, I wanted to include really complex AI for the dinosaurs," he explains, ruefully. "I wanted to give each one individual AI to make them much smarter so that they could understand the condition of the player better. I wanted them to be smart enough so that, when chasing the player, they could actually take a different route

It's possible to cradle a shotgun at waist level, bank-robber style, for quick, if rather scattershot, cartridge unloading, or hold it with butt to shoulder, sniper style, to maximise accuracy

in order to set up an ambush. The visuals – the dinosaur animations, for example – and audio aren't quite how I originally envisioned them, either. I was interested in the sounds the dinosaurs make when they cry out, and what appears in the game isn't what I had predicted."

It's obvious that this particular gaming visionary isn't packing up his take on the shock genre with *Dino Crisis*, though, and his passion has no doubt been fired by new technology. While his contemporaries deliver kids' games filled with cute characters bouncing around technicolour worlds, Mikami-san's territory remains far darker. "I want to express how I can use characters to frighten or panic people," he says. "And it's impossible to think about that for a young age group."



"I think it would be a good idea for the player to die if he does not stop the bleeding," says Mikami-san, "but that may not be practical"

# Depth 1 NO.1 FOR MAIL ORDER!

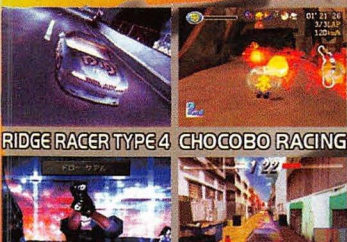

WE ARE THE MOST DYNAMIC NEW AND SECOND HAND MAIL ORDER COMPANY IN EUROPE AND WILL BEAT ANY ADVERTISED PRICE!!



ESTABLISHED OVER 6 YEARS. NO MEMBERSHIP FEES REQUIRED!! OVER 10,000 TITLES IN STOCK!! OPEN BANK HOLIDAYS!!



WE GET ALL THE MAJOR RELEASES ON THEIR RELEASE DATES. GET YOUR COPY THE NEXT DAY GUARANTEED!! HASSLE FREE!



IF YOU CAN'T FIND WHAT YOU WANT - CALL US

RELEASE DATE SUPPAGE MAY OCCUR. ALL PRICES CORRECT AT PRESS TIME. £600. HOWEVER, PRICES ARE SUBJECT TO CHANGE. MINIMUM AMOUNT CHARGED ON ALL CREDIT AND DEBIT CARDS IS £5.00. ALL COPYRIGHTS RESPECTED.

SWAP YOUR OLD GAMES FOR NEW!  
HOW IT WORKS:

WE WILL GIVE YOU 2/3 IN EXCHANGE OR 1/2 IN CASH OF THE PRICE WE SELL THE GAME FOR. WHEN YOU SEND IN YOUR COMPLETE AND UNDAMAGED GAMES. (WE ACCEPT CONSOLES AND PC HARD/SOFTWARE TOO!) FOR DETAILS RING US NOW.

WE HAVE THE BEST SELLING GAMES AT THE CHEAPEST PRICES IN EUROPE!

## NEW RELEASES

PlayStation™	
PAL/UK	
ALL STAR TENNIS '99	32.99
COLONY WARS 2: VENGEANCE	34.99
DRIVER	34.99
FA MANAGER	35.99
FIFA '99	29.99
GEX 3: DEEP COVER GECKO	34.99
GLOBAL DOMINATION	33.99
ISS PRO '98	30.99
KKND: KROSSFIRE	34.99
LEGACY OF KAIN: SOUL REAVER 2	38.99
METAL GEAR SOLID	33.99
MONKEY HERO	34.99
POPOLOUS 3: THE BEGINNING	31.99
PREMIER MANAGER '99	30.99
PRINCE NASEEM BOXING	33.99
RIDGE RACER TYPE 4	34.99
ROLLCAGE	29.99
TOCA TOURING CARS 2	29.99
TOMB RAIDER III	31.99
WCW/NWO THUNDER	29.99
WILD ARMS	29.49
X-MEN VS STREETFIGHTER	32.99
NTSC/US	
SILENT HILL	44.99
NTSC/JAP	
BUST A GROOVE 2: PARADISE MIX	53.99
CHOCOBO RACING: GENKAIHEND ROAD	53.99
FINAL FANTASY VIII	74.99
GRAN TURISMO 2	48.99
UNJAMMER RAMY (PARAPPA 2)	48.99
MARVEL SUPER HEROES VS S.F. EX	48.99

NINTENDO 64	
PAL/UK	
BEETLE ADVENTURE RACING	36.99
BUST A MOVE 3DX	34.99
CASTLEVANIA	32.99
F - ZERO X	28.99
FIFA '99	32.99
HYBRID HEAVEN	35.99
MICRO MACHINES 64 TURBO	34.99
MARIO PARTY	33.99
NBA JAM '99	36.99
STARSHOT	37.99
STAR WARS: ROGUE SQUADRON	35.99
WIPEOUT 64	34.99
ZELDA 64	37.99
NTSC/US	
DUKE NUKEM: ZERO HOUR	58.99
MARIO PARTY	58.99
QUAKE 2	58.99
TWELVE TALES: CONKERS QUEST	58.99
WINBACK	58.99

Dreamcast™	
NTSC/JAP	
CONSOLE & ACCESSORIES	
DREAMCAST CONSOLE	279.99
DREAMCAST ARCADE STICK	49.99
DREAMCAST PAD	29.99
DREAMCAST RACING CONTROLLER	69.99
DREAMCAST VMS	29.99
DREAMCAST VMS SPECIAL	34.99
STEPDOWN TRANSFORMER	24.99
GAMES	
AERODANCING	53.99
BLUE STINGER	58.99
GET BASS	
+ FISHING CONTROLLER	CALL
GODZILLA GENERATIONS	39.99
GREAT BUGGY	58.99
HOUSE OF THE DEAD 2 + GUN	CALL
INCOMING	39.99
MARVEL VS CAPCOM	58.99
MONACO GRAND PRIX SIM.2	53.99
PEN PEN TRIELCON	44.99
POWER STONE	58.99
PSYCHIC FORCE 2012	53.99
PURO PURO PACK	39.99
PUYO PUYO 4	53.99
SEGA RALLY 2	58.99
SONIC ADVENTURE	59.99
SUPER SPEED RACING	58.99
TETRIS 4D	39.99
VIRTUA FIGHTER 3TB	64.99
VIRTUA ON 2: ORATORIO TANGRAM	58.99

**METAL GEAR SOLID**  
ACTION FIGURES:  
SOLID SNAKE,  
LIQUID SNAKE,  
NINJA (LEFT), SNIPER,  
WOLF, PSYCHO MANTIS,  
REVOLVER OCELOT,  
MERYL SILVERBURGH.  
£14.99 EACH

CALL TO CONFIRM AVAILABILITY AND PRICES OF TITLES. PRICES ARE UPDATED ON A DAILY BASIS!

HAND HELDS	
POCKET GAMERBOY - 6 COLOURS	34.99
POCKET GAMERBOY - BACKLIGHT (GOLD, SILVER)	49.99
POCKET CAMERA	33.99
POCKET PRINTER	40.99
PRINT SEAL	6.99
LINK CABLE	6.99
FINAL FANTASY LEGENDS 1/2/3	18.49 each
FINAL FANTASY ADVENTURES	18.49
POKEMON (RED OR BLUE VERSION)	22.99
NEO GEO POCKET COLOUR	89.99
UK NEO GEO POCKET	47.99
PSU	14.99
KING OF FIGHTERS R-1	27.99
KING OF FIGHTERS R2	39.99
CUP '98	22.99
POCKET TENNIS COLOUR	34.99
TSUNAGE TE PON (PUZZLE)	22.99

Game & Watches  
Green: Donkey Kong Jnr Bros.  
Silver: Super Mario Bros.  
Red: Fire!  
Blue: Parachute  
£9.49 each

**GAME BOY COLOR**

GAMEBOY COLOUR	64.99
BOMBERMAN (USA)	18.49
TETRIS DX	18.49
ZELDA DX	22.99

**COLLECTABLES**

Bombeman soft toys (6 colours) £12.99 each

TALKING NINTENDO DOLLS £9.99 each

NINTENDO KEYSRINGS ONLY £4.99 EACH!

Banjo, Mumbo, Kazooie, Jumbo £6.99 each

Sonic & Tails toys £7.99 each

# BUY-SELL

# 0171 - 916 8440

LINES OPEN: MONDAY - SATURDAY 9.00am - 7.00pm  
SUNDAY 11.30am - 5.30pm

## CONSOLES & ACCESSORIES

### PlayStation™

**NEW**

PSX DUAL SHOCK PACK	89.99
SONY DUAL SHOCK PAD	17.99
MADCATZ STEERING WHEEL	39.99
PLAYSTATION SCART LEAD	7.99
SONY MULTI TAP	18.99
SONY OFFICIAL MEMORY CARD	8.99
SONY OFFICIAL MOUSE	18.99
<b>SCORPION LIGHTGUN/BIO GUN</b>	
WITH FOOT PEDAL FREE!	18.99
BLAZE MEMORY CARDS-8 COLOURS	7.99
NU-GEN DUAL IMPACT PAD	13.99
X-PLORER CHEAT CARTRIDGE	23.99
X-LINK CABLE & SOFTWARE	8.99
(X-PLORER TO PC)	

**2nd HAND**

SONY PLAYSTATION	80.00
SONY PLAYSTATION UNBOXED	70.00
NAMCO GUNCON	20.00
NAMCO JOYSTICK	22.00
NEGCON CONTROLLER	22.00
SONY DUAL SHOCK PAD	15.00
SONY PSX CONTROLLER OFFICIAL	5.00
SONY LINK CABLE	5.00

### NINTENDO 64

**NEW**

UK NINTENDO 64 GOLDENEYE	89.99
OR MARIO PACKS	
N64 V4 PASSPORT PLUS	14.99
TOP DRIVE STEERING WHEEL	45.99
(N64, PSX, SATURN COMPATIBLE)	
OFFICIAL COLOURED PADS	16.99
- SIX COLOURS	
OFFICIAL RUMBLE PACKS	11.99
OFFICIAL MEMORY CARDS	11.99
BLAZE MEMORY CARD	7.99
BLAZE RUMBLE PACKS	7.99
with 1MB memory	
BLAZE RGB SCART CABLE	7.99
RGB SCART CONVERSION LEAD	19.99
BLAZE A/V SCART LEAD	7.99
NU-GEN MANTA RAY JOY PAD	14.99
- 4 COLOURS	

**2nd HAND**

UK NINTENDO 64 BOXED	75.00
UK NINTENDO 64 UNBOXED	65.00
IMPORT NINTENDO 64 BOXED	92.00
IMPORT NINTENDO 64 BOXED RGB	108.00
IMPORT NINTENDO 64 UNBOXED	88.00
IMPORT NINTENDO 64 UNBOXED RGB	102.00
OFFICIAL COLOURED PADS	15.00
- SIX COLOURS	
OFFICIAL RUMBLE PACKS	8.00
OFFICIAL MEMORY CARDS	8.00

### SEGA SATURN

**2nd HAND**

IMPORT SATURN: BOXED	68.00
IMPORT SATURN: CONVERTED	70.00
UK SATURN: BOXED	30.00
UK SATURN: CONVERTED	62.00
SATURN JOYPAD	8.00
NIGHTS PAD	15.00
VIRTUA STICK	15.00
MEMORY CARD	15.00
MULTITAP	15.00

## 2nd HAND GAMES

### PlayStation™

**PAL/UK**

ACTUA GOLF 3	25.00
ACTUA SOCCER 2	10.00
ASTEROIDS	25.00
BUSHIDO BLADE	12.00
BUST A MOVE 2	15.00
CIRCUIT BREAKERS	22.00
COMMAND & CONQUER	12.00
CROC	10.00
COOL BOARDERS 2	25.00
DEATHTRAP DUNGEON	10.00
DIE HARD TRILOGY	18.00
DUKE NUKEM: TIME TO KILL	22.00
EARTH WORM JIM 2	10.00
FIFA '98	10.00
FINAL FANTASY VII	30.00
FORMULA 1	10.00
GRAN TURISMO	28.00
GRAND THEFT AUTO	18.00
INT. TRACK & FIELD	10.00
LIBERO GRANDE	28.00
LITTLE BIG ADVENTURE	18.00
LONE SOLDIER	10.00
MADDEN '97	10.00
MDK	10.00
MECHWARRIOR 2	15.00
MONSTER TRUCKS	10.00
NAGANO WINTER OLYMPICS	12.00
NEWMAN HAAS RACING	10.00
NUCLEAR STRIKE	15.00
PSYBADEK	10.00
RESIDENT EVIL 2	28.00
RIDGE RACER	10.00
SPOT GOES TO HOLLYWOOD	10.00
SPYRO THE DRAGON	28.00
STREET RACER	10.00
TEKKEN	10.00
TEKKEN 3	32.00
TOCA TOURING CARS	12.00
TOMB RAIDER	18.00
TOMB RAIDER III	28.00
V RALLY DUAL SHOCK	18.00
VICTORY BOXING	10.00
WARGAMES	18.00
ZERO DIVIDE 2	22.00

### NINTENDO 64

**PAL/UK**

1080 SNOWBOARDING	35.00
BANJO KAZOOIE	35.00
BODY HARVEST	25.00
BIO FREAKS	12.00
CHAMELEON TWIST	15.00
CLAYFIGHTER 63 & 1/3	10.00
DIDDY KONG RACING	30.00
DOOM 64	22.00
DUKE NUKEM 64	28.00

### NINTENDO 64 2ND HAND GAMES CONT.

EXTREME G	10.00
EXTREME G2	28.00
F1 WORLD GRAND PRIX	30.00
F ZERO X	25.00
FIFA 64	10.00
FIFA '98	18.00
FIGHTERS DESTINY	20.00
GOLDENEYE	32.00
GT 64	22.00
KILLER INSTINCT GOLD	18.00
LAMBORGHINI	18.00
MADDEN 64	15.00
MARIO 64	28.00
MARIO KART 64	32.00
MISCHIEF MAKERS	18.00
MISSION IMPOSSIBLE	30.00
MYSTICAL NINJA	30.00
NBA COURTSIDE	22.00
NBA PRO	15.00
PILOTWINGS	30.00
QUAKE	12.00
ROBOTRON 64	15.00
SHADOWS OF THE EMPIRE	28.00
TOP GEAR OVERDRIVE	32.00
TOP GEAR RALLY	22.00
TUROK	25.00
TUROK II	28.00
V RALLY	30.00
WAVE RACE 64	20.00
WAYNE GRETZKY HOCKEY	12.00
WETRIX	28.00
WORLD CUP '98	18.00
WWF WARZONE	32.00
YOSHI'S STORY	30.00
ZELDA 64	35.00

### SEGA SATURN

**PAL/UK**

ATHLETE KINGS	10.00
BAKU BAKU ANIMAL	12.00
BUST A MOVE 2	15.00
COMMAND & CONQUER	10.00
DAYTONA USA	10.00
ENEMY ZERO	22.00
FIGHTERS MEGAMIX	15.00
MANX TT	10.00
MEGAMAN X3	10.00
SHINING FORCE 3	22.00
SHINING THE HOLY ARK	12.00
SONIC 3D	12.00
SONIC JAM	12.00
SONIC R	12.00
STREET FIGHTER ALPHA 2	12.00
WORMS	10.00
X MEN	12.00

**OUR 2nd HAND PRICES ARE UPDATED ON AN ALMOST DAILY BASIS, SO CALL TO CONFIRM PRICE AND AVAILABILITY**

**THIS IS ONLY A SMALL SELECTION OF THE TITLES AVAILABLE! HUNDREDS MORE GAMES IN STOCK!!**

# EXCHANGE

DEPT. I, GROUND FLOOR,  
SUFFOLK HOUSE, 1 - 8 WHITFIELD PLACE,  
LONDON W1P 5SF

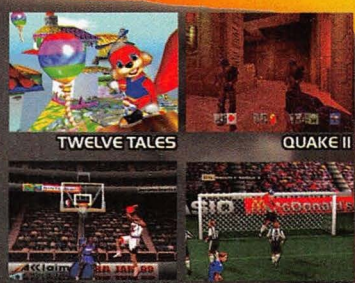

**NBA JAM '99** **FIFA '99**  
**NO QUIBBLE GUARANTEE!!**  
**NOT SATISFIED WITH YOUR PURCHASE?**  
**LET US KNOW WITHIN 2 WORKING DAYS AND WE WILL GIVE YOU A FULL REFUND**

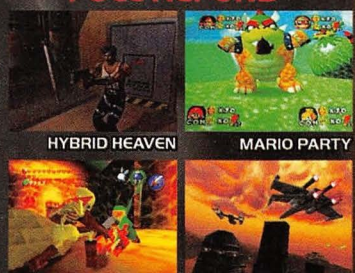

**ZELDA 64** **ROGUE SQUADRON**  
**FREE DELIVERY ON EVERYTHING!!**  
**OR PLACE YOUR ORDER BEFORE 6.30PM FOR GUARANTEED NEXT DAY DELIVERY FROM £3.50.**  
**FREE GIFT WITH ALL ORDERS OVER £10.00.**



**ALL PRICES INCLUDE VAT**  
**ABSOLUTELY NO HIDDEN EXTRAS!!**



**CHEQUES/POSTAL ORDERS PAYABLE TO DEPT. I**  
**WE DON'T CHARGE YOUR CARD UNTIL DESPATCH.**



Photography: Nick Wilson

Format: PC

Publisher: Mindscape

Developer: Eagle Dynamics

Release: June

Origin: Russia

Producer Nick Grey (foreground), director Igor Tishin (centre) and owner Neil Soane (behind)

# EagleDynamics

Russia is perhaps one of the last places people would look for a cutting-edge development studio, but **Edge** discovered that the ex-communist regime is full of surprises...

**I**t doesn't take long to realise things work slightly differently in Russia. Five minutes into a drive from Moscow Sheremettevo airport to the Aerostar hotel, **Edge's** cab is pulled over by traffic police. The driver wasn't speeding and there's no problem with the car's mechanical state (although, like every other car in Russia it is 20 years old and rusting to pieces). No, the law enforcers simply extort \$10 from the cabbie, and he's free to go. *Flanker 2.0* producer **Neil Soane**, sitting next to **Edge** in the backseat, doesn't look particularly worried. Instead, he looks at his watch and tuts, "not again." This, it seems, is a regular occurrence.

Despite the constant promise of reform, corruption is rife in Russia. It's an

existence, born out of desperation. With the collapse of communism in the late-'80s and the introduction of a decidedly unsteady free-market economy, the Rouble nose-dived in value, plunging much of the Russian population into poverty and crippling the previously iron-clad regime. And, of course, with capitalism came organised crime. According to **Nick Grey**, the owner of Eagle Dynamics, Russian Mafia activity is endemic – if you set up a company in Moscow, within days you will be visited by one or more of the local Mafia groups offering 'protection'. Just a week before **Edge's** visit to Eagle, the company was

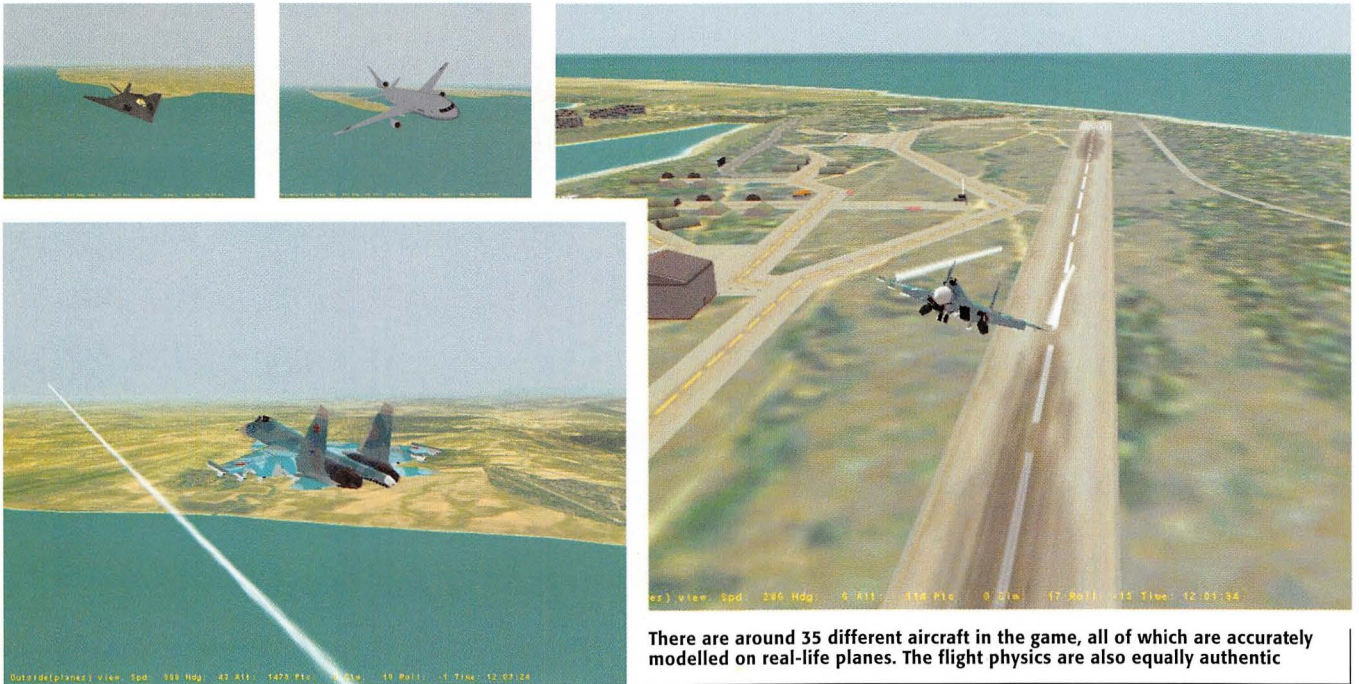

There are around 35 different aircraft in the game, all of which are accurately modelled on real-life planes. The flight physics are also equally authentic

**“There are more engineers per capita here than anywhere else in the world, but these guys have nothing to do. Many move to the US and end up driving taxis around”** Nick Grey

approached by two burly, well-dressed men who claimed to be representatives from a ‘strength system’. “They are very polite about it,” states Grey matter-of-factly, as though being doorstepped by gangsters ranked alongside a visit from a bunch of Jehovah’s Witnesses.

**Business as usual**

The Eagle Dynamics offices, part of an ugly ‘60s industrial building, are symbolic of the way businesses have to operate here. Behind the company’s five-inch-thick steel door sits an armed security guard, who – for the five hours **Edge** is in the building – doesn’t so much as get up from his seat. There are also several ‘guard’ dogs wandering around the grounds. Eagle’s director, **Igor Tishin**, was bitten by one and had to take antibiotics for 90 days. “There are a lot of rabid dogs around here,” he shrugs casually.

Once past the guard, walking into Eagle’s offices is like walking into the control room at NASA (or should that be Russian Space Agency, RKA...). Lots of incredibly intelligent people huddle over computer monitors surrounded by heavy tomes on aerodynamics, physics and aircraft design. This is not your usual

development studio. Many of the Eagle team come from the government design bureaus – elite engineering studios made up of the most talented pupils from Russia’s schools. These people have been trained for several years in special government universities specifically to take up military positions – designing aircraft, weapons, etc. With the collapse of the Soviet regime, however, many of those military positions ceased to exist. As Grey points out, “Russia is in deep financial and political crisis, but there is a lot of talent. There are more engineers per capita here than anywhere else in the world, but these guys have nothing to do. Many move to the US and end up driving taxis around. There is such a big pool of expertise, and no companies are using it.”

Eagle, though, certainly seems to be making the most of what Russia has to offer. *Flanker 2.0*, sequel to the moderately successful 1996 *Flanker SU-27* title, has been redesigned and re-coded from the ground up as a totally authentic, incredibly detailed flight simulator. The game, set over a 500x400km block of Russian landscape, gives the player around 35 different types of aircraft to include in missions, and around 20 different totally authentic weapons systems (you know they’re authentic because the guy who designed them was a colonel in the Russian army specialising in weapons systems). In *Flanker 2.0* every bomb and missile behaves realistically; different

warheads give different kill probabilities, and, on top of this, the collision detection is minutely accurate: “If a shell misses you by 20 inches, it misses you,” states Grey. “We deal with exact points, not fields of collision.” This is serious physics.

**Attention to detail**

The same clinical attention to detail is extended to the scenery. The landscape is based on military satellite data and electronic maps, making it more or less identical to the real-life locations. As Grey points out, “We’ve gone for quality rather than quantity in terms of landscape. We wanted to create a target-rich environment with lots of detail. It’s important to be able to blow stuff up, to fly in between buildings and to get an impression of speed. It’s better to have a lot of detail in a small area than to try to create the whole world and make it completely empty.” Consequently, there are well in excess of 100,000 3D objects strewn across the grasslands,



The decidedly unglamorous Eagle Dynamics HQ (top). A keyboard adapted for the Russian alphabet (above)



Nick Grey points out the many battleship models in the game



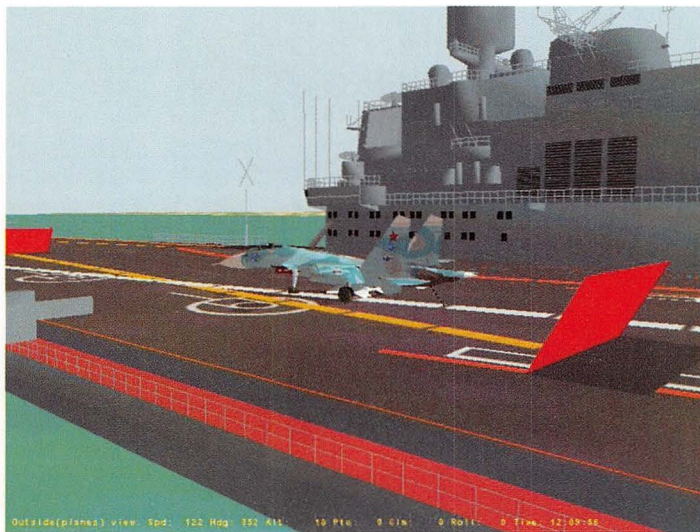

towns and villages in *Flanker 2.0*, and most of them can be destroyed. If you fly past a house you don't like the look of, you can fly by again, identify it as a target, and fire a missile at it. It's every psychotic propellerhead's wet dream.

Most impressive, though, is the sheer visual clarity. The landscapes look amazing, with an incredible wealth of terrain types, buildings, roads and structures jostling for space – and there is very little slowdown when you zoom over at very low altitude, practically skimming the roofs of houses. This is thanks to an excellent 3D engine written in a highly optimised assembler. "We can put 100 active objects into the player's vicinity at any one time without slowdown," claims Tishin. "What really slows the game are the complex weapon systems, but this is the fault of the PC hardware, not our software."

But Eagle is working with, rather than ignoring, hardware shortfalls. The team has designed its code to be highly scalable so that lower spec systems can still achieve

this incredible, smooth speed (at the expense of graphical detail, however). Speed and realistic flight physics are certainly the key guiding forces behind the project, and the latest developments in PC graphics – the introduction of AGP and more powerful graphics cards – are prompting even greater stretches towards realism – as Tishin confirms: "Even now, we are changing the graphics engine to keep up with technology." Eagle is determined not to get left behind.

**Mission control**

As for the game structure, things have been made as open as possible. There is a totally customisable mission system which enables players to choose their aircraft, weapons, type of mission (escort, intercept, reconnaissance, etc) and enemy targets, and then fly right into the action. To add to the realism, every enemy craft uses densely complicated AI routines, so they receive radar data, and react to it in realtime, continually asking questions

**All enemy and allied craft have their own mission objectives. Plus, they employ sophisticated AI routines to achieve them**

about their environment, weighing up risks and looking for launch possibilities. Players can also set enemy skill levels to keep the challenge relative to their own experience.

For those who want a more structured game, however, *Flanker 2* also contains a highly flexible campaign mode. Here, when players attempt a mission, their performance dictates what the next phase of the campaign will involve. So if you're asked to blow up a battleship, and you fail, the next phase will have you going back, with two or three computer-controlled planes by your side as back up. If you succeed, you'll move on to the next objective. According to Grey, there are around 100 pre-scripted variations for each phase, which means the game is radically different each time you play, without resorting to a mathematically complex and framerate-slowng 'dynamic' system (which generates things for the player to see and do on the fly).

Importantly, though, Eagle has recognised that not every gamer wants to



**Collectively, the Eagle team has a higher average age than most. Many of the team have spent years working for the military, designing real warcraft**

**The Eagle has landed**

Eagle Dynamics was set up in 1989 by British businessman and flight enthusiast Nick Grey, whose diverse remit also includes selling Lear Jets in Eastern Europe and managing Duxford Air Museum near Cambridge. The team was originally part of a small aviation design company Grey set up in Russia, and their task was to write CAD software for use by the aircraft designers. However, Grey felt that the software, which took several years to perfect, would make a great basis for a flight sim game, and so *Flanker 1.0* went into development.

After the game was released in 1996, almost the entire Eagle outfit was poached by Microsoft and moved out to the US. Consequently, Grey employed a brand new team for the sequel from a diverse selection of professions – one programmer designed landing algorithms for the Russian 'Buran' space shuttle, others came from government design bureaus, and Igor Tishin, who joined the company back in 1991, is a Doctor of Science specialising in missiles (specifically nozzles for missile boosters). It's certainly a well-qualified collective.



The team plans its schedule on a massive blackboard (top). The armed guard (above) protects the team from any unwanted visitors

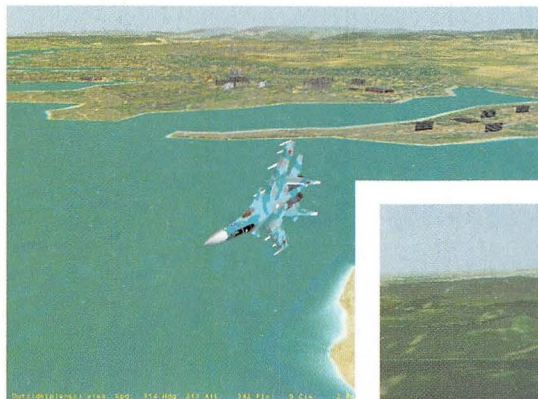

The mission editor (top right) enables players to define their own tasks

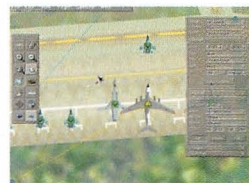

prove his mettle as a real pilot – some just want to have fun. *Flanker 2.0*, then, comes with a scaleable arcade mode in which players can turn off all collision detection so the plane actually bounces along the ground without exploding. This option also includes completely automatic weapon selection – as simple as pulling the trigger at a target; the computer decides what weapon to use and preps it accordingly. This could well prove the vital linchpin in securing a mass audience for what is, in essence, a military-level simulator.

### World War Web

Network play has become an essential part of the flight sim genre (especially in the US), and it certainly hasn't been neglected here. Eagle already has a 16-player LAN mode up and running, but hopes to extend that to support up to 32 players. The team's long-term ambition is to create an homogeneous 'digital combat environment' either over LAN or the Internet which players can enter when they like and take part in multiplayer

campaigns. "Our ultimate aim is to get all the titles coming out of Mindscape's simulation group talking to each other over LAN or the Net," explains Grey, "but for that you need a common graphical standard. You also need to filter all the information into each player's mission, so everyone is relevant – everyone's actions have an impact on the game environment."

In short, Eagle is imagining a sustained online world – like *Ultima Online* or *Meridian 59* – where players with the appropriate software – be it a tank, flight, or battleship simulation – can enter at any time, link up with a platoon and get involved in a military campaign. It's a fascinating idea, but one that's a few years away yet. "We have to make *Flanker* a

commercial title – a *Falcon* beater – before any of this can take place," admits Grey.

After finishing at Eagle, Igor Tishin and Nick Grey take **Edge** on a tour of Moscow, an incredibly beautiful city jammed with imposing imperial architecture and those strange Russian Orthodox churches. Grey claims that a previous Tsar of Russia chose orthodox Christianity as his country's religion because it was the only one that allowed drinking. True to stereotype, drinking is pretty much a way of life here – vodka, the nation's poison of choice, is almost thought of as a medicinal substance. Not all stereotypes are accurate, though – Moscow citizens enjoy a vibrant, diverse nightlife, shattering the common image of a dour and depressing country.

As for Eagle, although *Flanker 2.0* is currently taking up most of its time, it is constantly planning ahead. Not only does it have ambitious network plans, but the next *Flanker* title – *Flanker SU-25* – is already in development, and features more concentration on ground attack missions. Before that, Nick Grey confidently predicts that *Flanker 2.0* will set a world standard for flight simulation. Having seen the game in action, and witnessed the incredibly detailed aircraft models winding over elaborate landscapes at nauseating speeds, **Edge** finds it hard to disagree. Indeed, **Edge** is afraid to disagree. There is an armed guard on the door, after all.



### Selling games in Russia

Although by western European standards, the videogames market in Russia is pretty small, there is a demand for new software. At the moment, the biggest-selling game in the country is *Counter Action* – a patriotic tank warfare sim which has so far shifted 40,000 copies.

However, as corruption is par for the course here, the process of distributing games as we know it is totally different. For a start, you can more or less forget trying to sell original copies of your games; an

official boxed copy of a game retails at around \$30 (prohibitively expensive for most Russian gamers) whereas a pirated version will cost around 2 or 3 dollars. Predictably, piracy is rife – there's even a market in Moscow – Garboushka market – bursting at the seams with stalls selling pirated videos, cassettes and videogames, and it is largely tolerated by the authorities.

In such a situation, there is little point in trying to fight against piracy. Instead, companies have to try and

work with it. Recently an organisation named Shield has appeared, through which software companies can actually deal with pirates. The latter simply pays a fee to copy a certain number of games, and then distributes them through channels such as Garboushka market. Shield receives a commission from the software publishers and actually manufactures the copies itself, so it can control how many the pirates get their hands on. To paraphrase the famous saying, 'If you can't beat 'em, control 'em.'

## Edge back issues

### ISSUE 65 DECEMBER 1998

**News** Tokyo Game Show; Dreamcast line-up  
**An audience with...** Eidos' Ian Livingstone  
**Prescreen** *Virtua Fighter 3tb*, *Lander*  
**Prescreen spotlight** *Black and White*  
**Testscreen** *Body Harvest*, *Crim Fandango*  
**Features** Online gaming; A Question of Character

### ISSUE 66 CHRISTMAS 1998

**News** Dreamcast setbacks; PlayStation emulation  
**An audience with...** Andreas Whittam-Smith  
**Prescreen** *Mario Party*, *Grandia II*, *Geist Force*  
**Prescreen spotlight** *Silent Hill*, *Climax Landers*  
**Testscreen** *Zelda: Ocarina of Time*, *Half-Life*  
**Features** Pocket Battlechips; Food for Thought  
**Plus** 1999 game art calendar

### ISSUE 67 JANUARY 1999

**News** Dreamcast launch report; Voodoo3  
**Prescreen** *Shadowman*, *Driver*, *Zombie Zone*  
**Prescreen spotlight** *Hired Guns*, *Soul Bringer*  
**Testscreen** *Virtua Fighter 3tb*, *Thief*, *Heretic II*  
**Features** The Best of 1998; Physics Matters  
**Plus** Exclusive Dreamcast supplement

### ISSUE 68 FEBRUARY 1999

**News** Milia '99; Dreamcast import scene  
**An audience with...** Jean-François Ceccillon  
**Prescreen** *Jet Force Gemini*, *Kingpin*  
**Prescreen spotlight** *Quake III*, *Gran Turismo 2*  
**Testscreen** *Sonic Adventure*, *Ridge Racer 4*  
**Features** Learning Curves; Man Versus Machine

### ISSUE 69 MARCH 1999

**News** PlayStation 2; N64 emulator UltraHLE  
**An audience with...** DMA's Gary Penn  
**Prescreen** *Aliens Vs Predator*, *Darkstone*  
**Prescreen spotlight** *Giants*, *Shenmue*  
**Testscreen** *Sega Rally 2*, *Rollcage*, *Mario Party*  
**Features** Celebrating the Amiga; Reality Bytes

### ISSUE 70 APRIL 1999

**News** Sony's next generation PlayStation  
**An audience with...** John Carmack  
**Prescreen** *V-Rally 2*, *GTA London*, *Undercover*  
**Prescreen spotlight** *Crazy Taxi*, *Rally Masters*  
**Testscreen** *Power Stone*, *Silent Hill*, *Silver*  
**Features** Switched On; The Truth is Out There

# subscription offer

save 30% – that's up to £12  
off the cover price

£29.95 by Direct Debit (UK only) £34.95 by cheque or credit card (UK only)  
£59 Europe £79 rest of world

12 issues delivered free

Edge is delivered post-free within the UK.  
Overseas postage charged at cost

## stay informed

With an **Edge** subscription you'll be kept up-to-date with all the latest games industry news, previews, reviews and features. By taking out a subscription now, you'll not miss a single issue over the coming months

call the edge subscription

hotline: 01458 271112\*

or email: [subs@futurenet.co.uk](mailto:subs@futurenet.co.uk)\*

You can cancel your subscription at any time and get a refund for all un-mailed copies.

\* Important: quote reference no. EDGP71 when telephoning or emailing your order

## how to subscribe

### By Direct Debit – saving £5:

Complete and return the subscription card by post – don't fax or photocopy it. Remember to complete the mandate.

### By cheque or credit card:

Complete and return the subscription card or contact us via:

telephone  
fax  
email  
the world wide web

Subscriber Hotline: 01458 271112\*  
01225 822523  
[subs@futurenet.co.uk](mailto:subs@futurenet.co.uk)\*  
<http://www.futurenet.co.uk/edge/html>

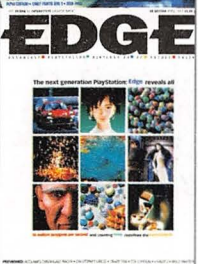
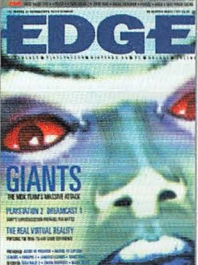
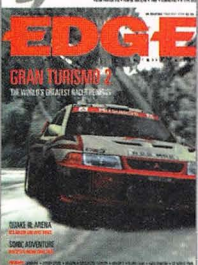
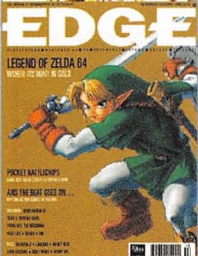

£5 each\*

\*£8 outside of Europe

£6 each

The **Edge** slipcase is the ideal way to keep older copies in mint condition



RESERVE YOUR COPY TODAY.  
Tell your local newsagent to reserve or deliver your copy of **Edge** on a regular basis

# TOKYO GAME SHOW

Expectations were high as gamers and press alike flocked to see what ammunition the console giants had to do battle with each other. Ultimately it was a case of handbags at ten paces, with hardly a shot fired in anger

今回のゲームショーでは  
次世代プレイステーション  
に関する出展はしておりません。  
ご了承ください。

Please be informed that there are no  
displays regarding the next generation  
PlayStation at this show.  
Thank you.

Sony Computer Entertainment Inc.

**S**CEI's austere sign just about sums up the spring '99 Tokyo Game Show, littered as it was with disappointing Dreamcast titles and half-baked PlayStation games:

'There are no demonstrations of the next generation PlayStation at this show'. In a single sentence, Sega's arch rival swept the wind from its own sails.

Sony might as well have offered a return coach back to central Tokyo from the Game Show's capacious location within the Makahari Messe exhibition centre, although it did put on a fine effort for the launch of *Um Jammer Lammy*. Just as telling as the crowd of journo and Otaku gathered before *Lammy's* antics was the game's positioning on the shelves of HMV in Tokyo's Shibuya district – stacked innocuously beside the latest Japanese pop releases, it was abundantly clear how pervasive PlayStation culture has become. Sony would be hard pressed to drop the ball now, although even Nintendo struggled to shift its consumers from Famicom to Super Famicom. Time will tell, of course.

In some respects, the most significant title nestling beneath the expensive and expansive stands at TGS was Namco's Dreamcast conversion of its System 12 coin-op *Soul Calibur*. Boasting hugely improved graphics, if nothing else the game was a statement of intent by the Japanese giant. Sega has to secure the support of major players like Namco if it is to mount a serious challenge on the mass market.

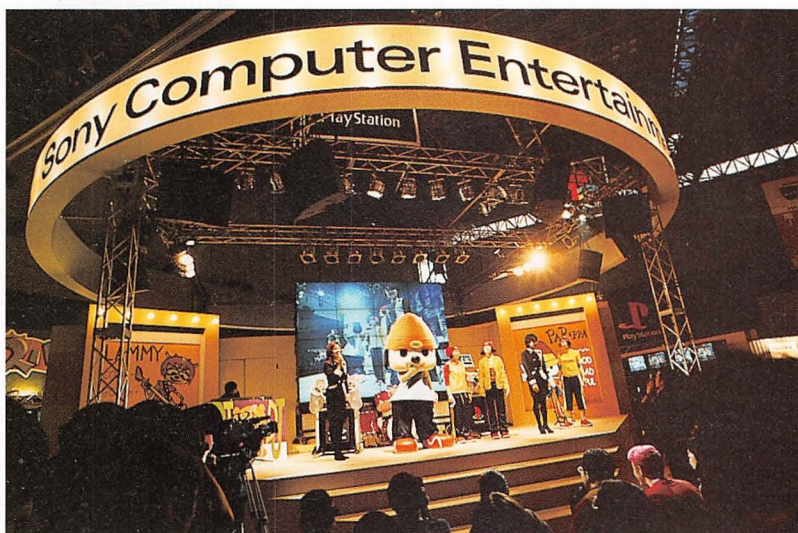

Photography: Hiroki Izumi

If one theme typified the spring Tokyo Game Show, it was music. Konami's stand drew the crowds with its BeMani titles, while Sony presented interactive *Um Jammer Lammy* sessions

While the impatient hordes of Otaku found much to sate their hunger, many more discerning visitors were left wondering quite what all the fuss was about. The number of exciting, innovative new titles could be counted on one hand

That said, *Soul Calibur* was playable and slick, which is more than could be said of Capcom's *Bio-Hazard: Code Veronica* for Dreamcast. Several disjointed scenes from the title were included in a special video presentation on the stand of Capcom (which gave pride of place to the superb but apparently underselling *Power Stone*, 9/10 **E70**), complete with animation dragged straight from the PlayStation versions. Shown in the same footage was *Dino Crisis* for Sony's console (see p40), which held more appeal.

Sega's own stand (see over) was only matched in size by Namco's, yet offered rather more to see (the latter bringing a grand total of three games to the show). Visitors to the booth were able to sample Konami's *Air Force Delta* (visually accomplished and previously known as *Flight Shooting* – see **E68**), *Get Bass!* (okay) and *Maken X* (strikingly basic) among others. Pride of place,

however, was given to *Shenmue* – which is entirely understandable given its 'Titanic'-like development cost. Several action sections were available for play, although, as one Sega bod was keen to stress, the real value in *Shenmue* lies in experiencing its storyline.

While the impatient hordes of Otaku who flooded onto the show floor found much to sate their hunger (not least from the multitude of merchandise vendors which set up camp on the show's periphery), many more discerning visitors were left wondering quite what all the fuss was about. The number of exciting, innovative new titles on offer could be counted on one hand. The dearth of must-have Dreamcast games was deeply worrying, particularly at an event which should have belonged to Sega. The pressure on those western 1.5-party games to impress has never been greater.

Still, on with the highlights (and lowlights) of the show... 

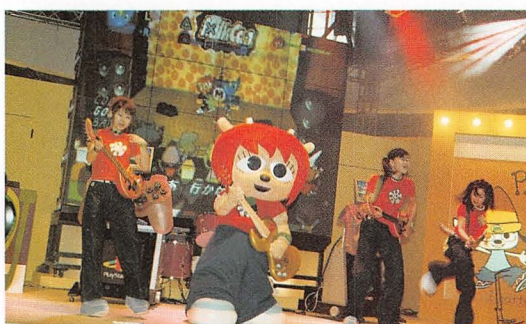

Although Sega had a huge stand (left) and many new Dreamcast games (far left), the populist showgoers were more easily seduced by the new wave of brash, music-driven titles (above)

# SHENMUE

By far and away Sega's most important and impressive title at the show was its \$20 million epic, *Shenmue*. Publicly playable for the first time, the Yu Suzuki-produced title was perhaps done a disservice by being represented via a handful of game sequences.

While reasonably interesting from a conceptual standpoint, the notorious QuickTime Events proved worryingly reminiscent of playing infamous laserdisc title *Dragon's Lair*. The realtime fights were more promising, but for a such a plot-driven title, the combat sections will form only a small part of the picture.

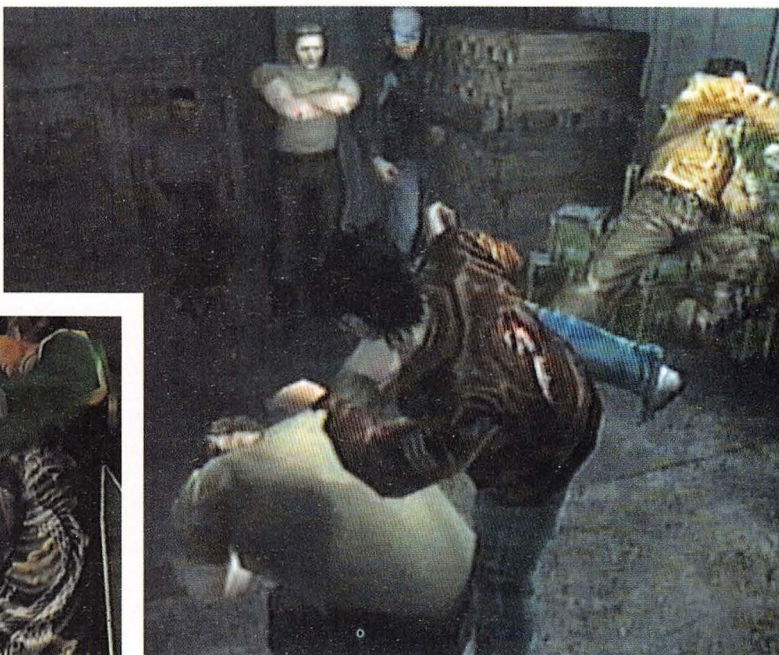

Sega's exquisite preproduction work, including statue-like character models, revealed some of the enormous effort that has gone into the creation of *Shenmue*.

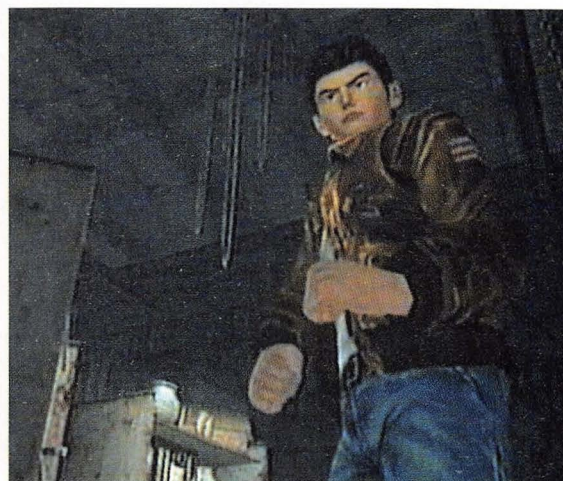
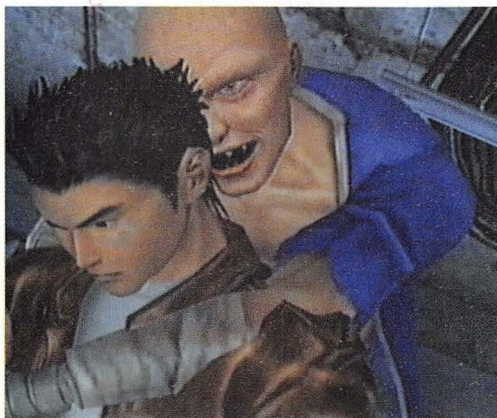
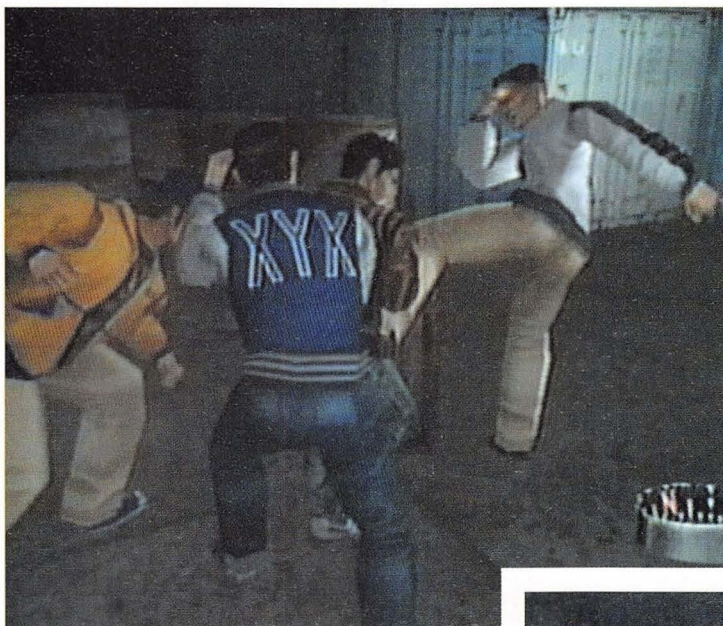

Platform: Dreamcast

Publisher: Sega

Developer: In-house

# SOUL CALIBUR

Video stills such as these undersell the low-frequency sonic boom that *Soul Calibur* represents to Dreamcast. Easily dismissed due to the coin-op's second-rank status among the cognoscenti, the title has been hugely reworked and graphically enhanced for Sega's console. That Namco has made that effort is significant in itself. Oh, it plays well, too.

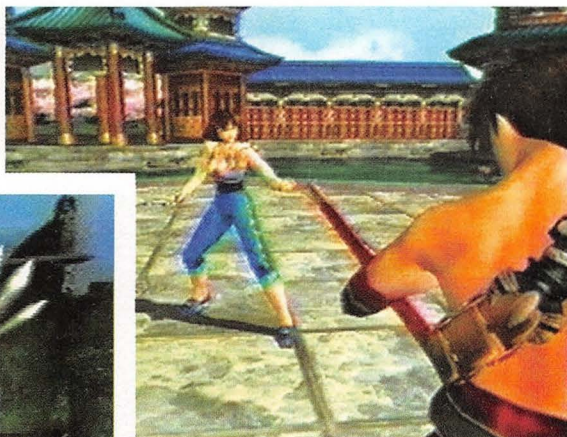

Platform: **Dreamcast**

Publisher: **Namco**

Developer: **In-house**

# BIO-HAZARD: CODE VERONICA

Displayed only on video, the forthcoming Dreamcast version of *Bio-Hazard* was intriguing in some ways – and downright depressing in others. While the realtime settings show great detail, the PlayStation version's limited character animations have been retained. Also of concern is the fact that Capcom has handed over development duties to an external team.

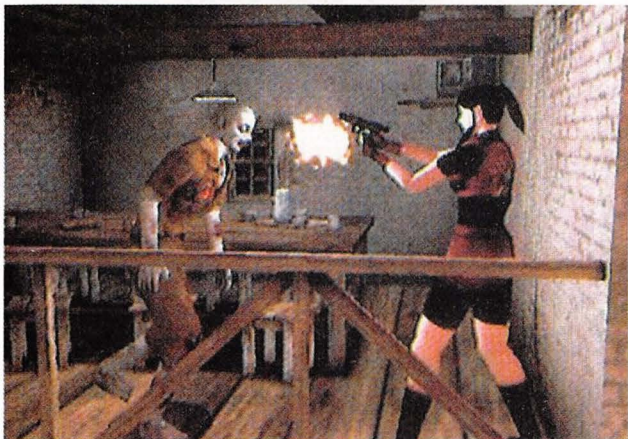
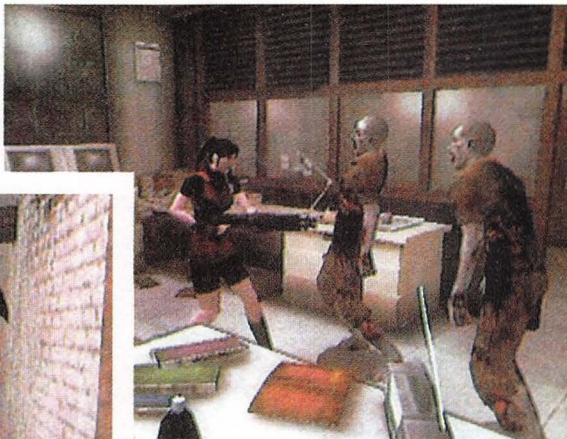

Platform: **Dreamcast**

Publisher: **Capcom**

Developer: **Sega**

## GUNDAM GAIDEN

Pandering to the ongoing Japanese love affair with giant Mech battles, Bandai has created *Gundam Gaiden* for Dreamcast. While the concept is tried and tested, less could be said of Bandai's preferred control system, which made its game extremely difficult to enjoy. Couple that with a wooden sense of movement, and *Edge*, understandably, was left cold.



Platform: **Dreamcast**

Publisher: **Bandai**

Developer: **In-house**

## AIR FORCE DELTA



Previously tagged as the overly descriptive *Flight Shooting*, Konami's *Air Combat* clone drew considerable interest from TGS attendees – not least for being playable with ASCII's odd new Dreamcast flight stick. Seemingly of a higher quality than *Aero Dancing* (see p74), *Air Force Delta*'s military skew is certain to interest shoot 'em up fans.

Platform: **Dreamcast**

Publisher: **Konami**

Developer: **In-house**

# MAKEN X

Japanese gamers are notoriously disinterested in firstperson titles. The Japanese development community's subsequent lack of experience in creating such games revealed itself in the form of *Maken X*. Unless Atlus deliberately demonstrated a dumbed-down version at the show, the title was artistically strong but simplistic in gameplay terms.

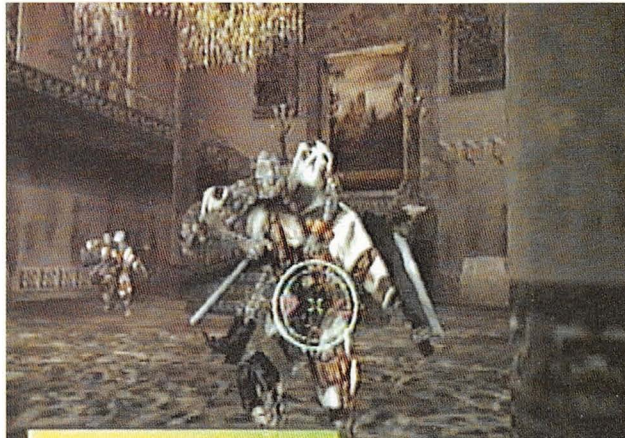
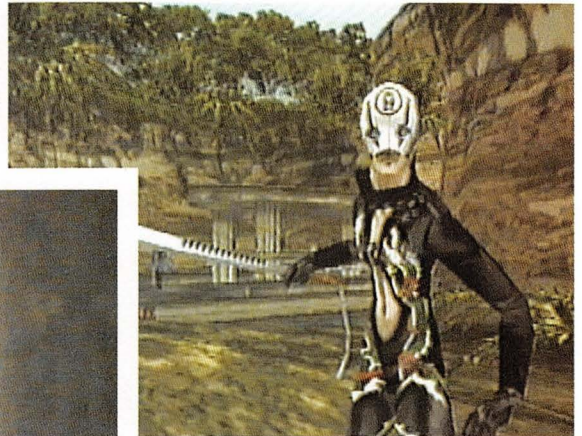

## BASEBALL TEAM

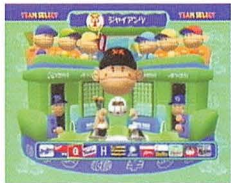

Let's *Make a Baseball Team!* was one of the more popular titles on Sega's stand, no doubt due in some part to its super-deformed characters and colourful visuals. A western release seems unlikely.

Platform: Dreamcast

Publisher: Sega

Developer: In-house

Platform: Dreamcast

Publisher: Atlus

Developer: In-house

# FRAME GRIDE

## HIGHWAY BATTLE

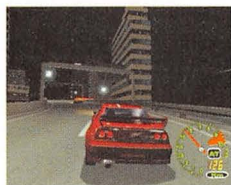

Having been responsible for the well-received *Armoured Core* series on the PlayStation, From Software has moved into the vanguard of Dreamcast game development with *Frame Gride*. Significantly, the company's new title makes good use of the Dreamcast modem, and featured on Sega's stand as an example of online gaming's potential.

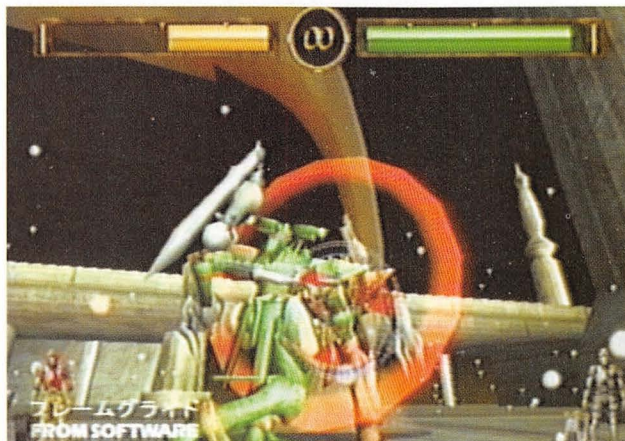
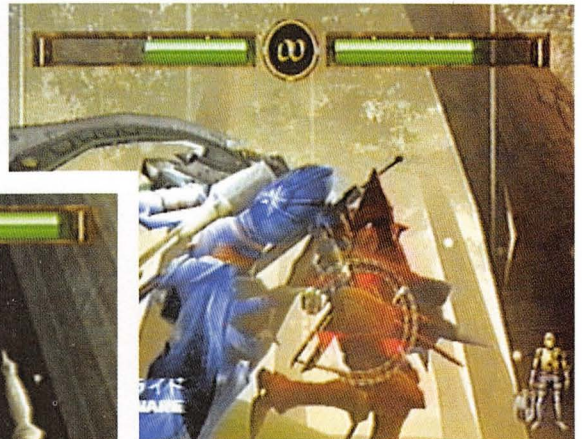

Looking vaguely similar to Konami's 1998 coin-op *Racing Jam*, Genki's *Tokyo Highway Battle* has some way to go before challenging *Gran Turismo* in the dynamics stakes.

Fully previewed on p32, the game's visual prowess is currently marred by a massive decrease in speed when you switch to the exterior viewpoint.

Platform: Dreamcast

Publisher: Genki

Developer: In-house

Platform: Dreamcast

Publisher: From Software

Developer: In-house

*The House of the Dead 2*: a rare shooter at TGS

Sega's connectivity commitment was heavily sold

*Shenmue* was given pride of place on Sega's booth





# SEAMAN

Ambitious, offbeat Japanese developer Yoot Saito (see E67's Dreamcast supplement) is starting to see his plans for artificial sealife title *Seaman* come – amazingly – to fruition. Perhaps more startling was the amount of space Sega dedicated to the title (*Edge* hesitates to call it a game) at TGS.

While nothing was actually playable, someone – somewhere – has enough belief in the potential of Saito-san's creation. It's believed that Sega views *Seaman* as an opportunity to enter new markets.

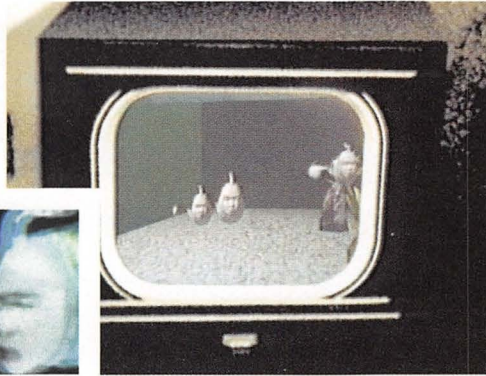

Platform: Dreamcast Publisher: Sega Developer: Yoot Saito

# GET BASS!

Coupled with ASCII's dedicated Dreamcast controller, Sega's home conversion of AM3's remarkably addictive coin-op hooked the attention of many passers-by. Although ASCII's fishing stick was never likely to match the arcade cabinet's own force-feedback rod, the Dreamcast version looks extremely close to the original Model 3 iteration.

With fishing games a popular genre in Japan, *Get Bass!* should do well there, but it could prove one custom controller too many for the west.

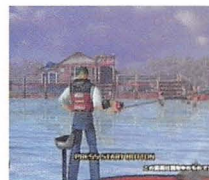
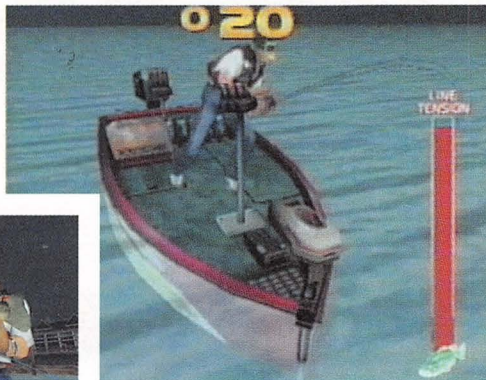

Platform: Dreamcast Publisher: Sega Developer: In-house

# D 2

Far from appearing as the DC launch title it was once cited to be, Warp's *D2* has now slipped to somewhere around the end of '99. Trailers for the game carry the message that 'Something is under the frozen soil in Canada and now it's awake', but as yet little is known about the gameplay system.

Graphically, *D2* has some truly gross moments, with 'Alien'-esque burblings from human bodies and eyeballs popping out. However, the snow mobile section (below left) seems worryingly poor.



Platform: Dreamcast Publisher: Sega Developer: Warp

# FOOTBALL TEAM



If Sega Europe can launch on Sep 9 with a football title which matches *Let's Make a Football Team!* in the graphical stakes, then massmarket attention will be assured. It's unclear just how much action *Football Team!* offers – the game allows you to pick the club secretary, which shows management leanings – but it looks the part.

Platform: Dreamcast  
Publisher: Sega  
Developer: In-house

*Densha de Go! 2*: one of TGS's most popular titles

Konami's few non-music titles held little interest

The attraction of Square's stand was typically strong



# LEGEND OF MANA

Though its precursor, *Seiken Densetsu 3*, did not officially make it to the west, the game which preceded that, the classic SNES action-RPG *Secret of Mana*, did. And that's why this full-blown sequel was one of the hottest TGS titles. The rather lurid graphics may betray the SNES original's elegance, but the gameplay promises to be as thoroughly engrossing.



Platform: **PlayStation**      Publisher: **SquareSoft**      Developer: **In-house**

# RACING LAGOON

Pride of place on Square's TGS stand went to *Racing Lagoon*, a 'high-speed driving RPG' (according to the company's promotional materials). The core of the game takes its inspiration from the likes of *Gran Turismo* (right down to the environment-mapped reflections on car bodywork), but myriad embellishments make this more than a simple clone.

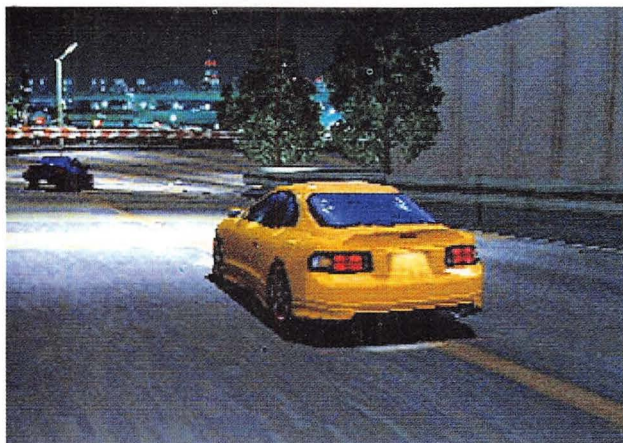

Platform: **PlayStation**      Publisher: **SquareSoft**      Developer: **In-house**

Square's booth presented a number of surprises

Capcom, once again, majored on beat 'em up titles

*Front Mission 3* was yet another Square PS offering



Namco's showing proved rather underwhelming – an unsurprising fact, given the company's full-on commitment to producing titles for the next generation PlayStation, a task that is sapping the reserves of its voluminous banks of design and coding creatives

# CHOCOBO RACING

Square presented its new racer in challenge form (the company arranged competitive time trials for four attendees at a time throughout the event), and interest was relatively high. The game offers a bunch of variably talented characters and a selection of track styles over which to race. To call this game a clone of *Mario Kart 64* would be to rather understate the situation – some of the tracks look almost identical at first glance. Ugly pop-up is one of the most visibly clear differences, though.



Platform: **PlayStation**      Publisher: **SquareSoft**      Developer: **In-house**

# LORD OF FIST

Mediaworks is hardly a proven name in the gaming world, but its new beat 'em up shows promise, if only because it veers slightly from the well-worn path beaten by the *Tekken*-likes beloved of so many misguided developers. It sells itself on its multiplayer capabilities: it's possible, using a multitap, to set up simultaneous fourplayer fights. The graphics may be on the basic side, but its concepts are sound.

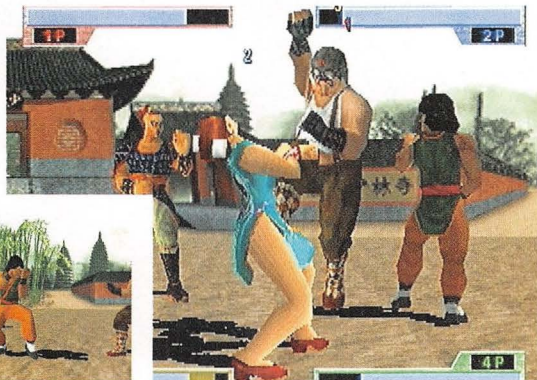

Platform: **PlayStation**      Publisher: **Mediaworks Inc.**      Developer: **Polygon Magic**



Namco's *Ace Combat 3* proved one of the company's biggest draws, its cutting-edge graphics engine (in effect a tweaked version of *Ridge Racer Type 4*'s guts) representing air-based action in a fashion PlayStation followers found all too seductive

# OMEGA BOOST

Despite having failed to blow away attendees of Sony's private software showing in March, Polyphony's 360-degree blaster drew much attention at the show – partly because attendees were forced to form an orderly queue in order to enter the section where the game was being demonstrated. Lively visuals are perhaps the title's biggest draw, but its full-on, no-frills gameplay has appeal, too.



Platform: **PlayStation**      Publisher: **Sony**      Developer: **Polyphony Digital Inc.**

Sony's *Um Jammer Lammy* pulled in hardcore fans

Few things raise an eyebrow at TGS

*Dragon Valor*, an action-RPG from Namco, impressed



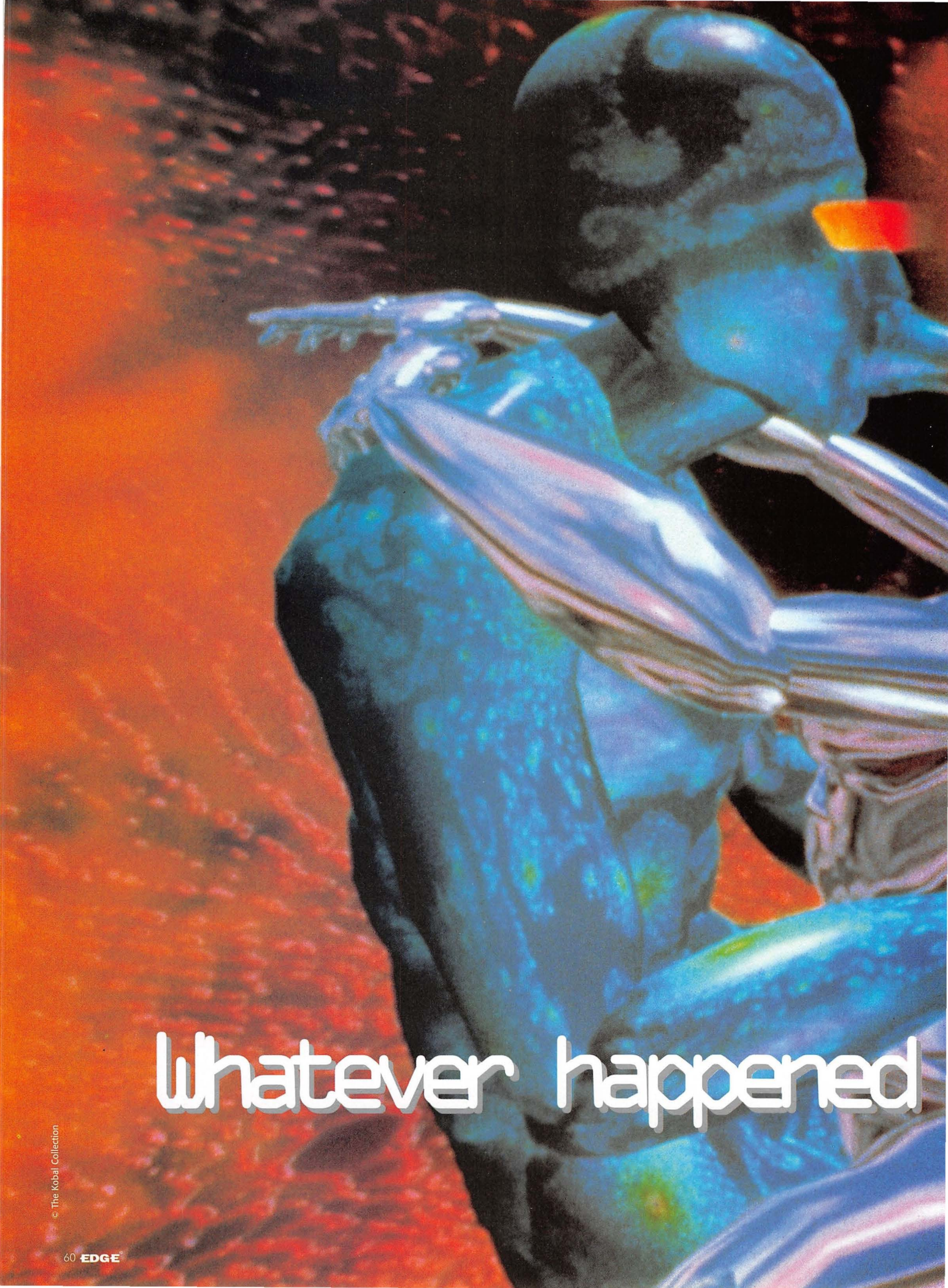

# Whatever happened

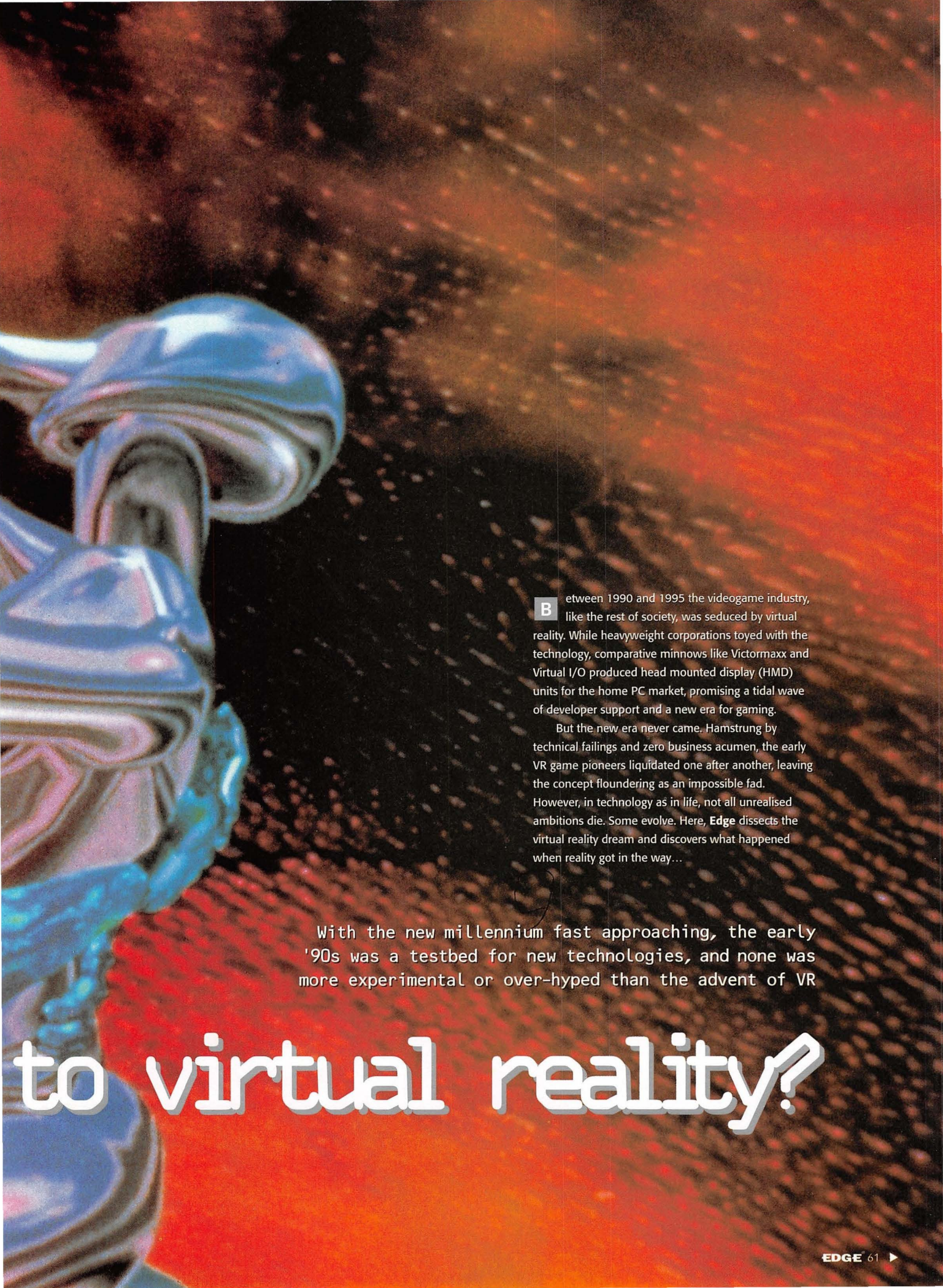

**B**etween 1990 and 1995 the videogame industry, like the rest of society, was seduced by virtual reality. While heavyweight corporations toyed with the technology, comparative minnows like Victormaxx and Virtual I/O produced head mounted display (HMD) units for the home PC market, promising a tidal wave of developer support and a new era for gaming.

But the new era never came. Hamstrung by technical failings and zero business acumen, the early VR game pioneers liquidated one after another, leaving the concept floundering as an impossible fad. However, in technology as in life, not all unrealised ambitions die. Some evolve. Here, **Edge** dissects the virtual reality dream and discovers what happened when reality got in the way...

With the new millennium fast approaching, the early '90s was a testbed for new technologies, and none was more experimental or over-hyped than the advent of VR

# to virtual reality?

## Virtual reality is dead

*'Virtual reality is an industry on the edge of crossing the magic barrier that separates dreams from commercial reality, yet at the moment it is more reminiscent of the old Wild West in the gold-rush days. Desperate to stake their claims, hopefuls are racing toward the horizon; elbowing, pushing, and not worrying much if their wagon has rolled over a rival's foot, so long as they get there first!'*

From 'Glimpses of Heaven, Visions of Hell: Virtual Reality and its Implications' by Barrie Sherman and Phil Judkins, published in 1992

**"VR is here, and has been for quite some time. But if we only define it as wearing clunky head-mounted displays, full body suits and datagloves, we might just miss VR all together"**  
Bob Berry, ZeroKast Inc.

It was a year after the above VR polemic was released that the first 'virtual reality' head-mounted display units appeared for home computers. Headsets by the likes of Victormaxx and Forte Technologies uniformly featured two LCD screens which could be programmed to produce a slightly different image for each eye, thereby creating the appearance of true depth. They could also track the movement of a player's head and alter the onscreen view accordingly. Riding on the back of the early '90s media VR frenzy, it looked as though home VR just couldn't fail.

Unfortunately, however, the endeavour was riddled with problems. For a start, home HMDs were expensive – the Cybermaxx headset retailed for £580, which immediately placed it beyond the reach of most gamers. Given the esoteric nature of the market, then, developers did not see the point of writing the code required to support the headsets fully, and even when they did make the effort (*Descent*, *Heretic* and *Hexen* all supported the 3D offset capabilities of Virtual I/O's Virtual i-Glasses), pre-Pentium and pre-Voodoo PCs just couldn't generate the necessary framerates.

More importantly, though, the HMD technology itself was fatally flawed: as VR veteran **Ben Vaughan** – now vice president on a project named Intertrax at

### FROM NASA WITH LOVE

Before the Internet entered public consciousness in the mid-'90s, VR was the new bold dream of computer technology. Although the term was coined by techno-guru Jaron Lanier in 1986, the actual conception goes back much further. MIT luminary Ivan Sutherland (co-founder of computer graphics company Evans and Sutherland, and widely credited with inventing computer-aided design) built the first VR head-mounted display in 1966 while an associate professor at the University of Utah. From here, the notion of a computer-simulated 3D environment into which the user could be completely absorbed was explored by various academic and research establishments throughout the '70s and '80s. Inevitably, the US army became interested in the simulation potential of the medium and built its own VR setup in 1982 – the technology was gradually gathering credence.

It is NASA, however, that's credited with kickstarting mass interest in the phenomena. In 1984, research employee Michael McGreevy obtained a \$10,000 grant to build a VR simulator, based on army technology. Unfortunately, the kind of system developed at the Wright Patterson Airforce base in '82 would have cost more than a million dollars to purchase. Instead, McGreevy went down to Radio Shack, bought two handheld TVs, attached them to a helmet, added an Evans and Sutherland Picture System 2 graphics computer, and built the first practical VR system for \$2,000. VR became a commercial reality.



The Cybermaxx HMD by Victormaxx featured poor quality lenses which "induced eyestrain"



Virtual I/O produced a bearable lightweight headset, but wasted all its money on marketing



Hasbro sunk millions of pounds into a virtual reality console project, only to abandon it



Atari's plans for a Jaguar VR headset fell apart when the company itself began to self-destruct



The failure of the Virtual Boy was perhaps the straw that broke consumer VR's back

VR company I Sense – recalls, "Victormaxx failed because the product was badly designed. The optics were very poor and induced eyestrain, it had a simplistic tracker that induced simulation sickness and had poor resolution (approx. 100,000 pixels). On top of that they rushed the manufacturing and consequently had more than 50 per cent warranty returns on the first 25,000 units shipped. Essentially, they completely alienated their early-adopter market."

According to Vaughan, this was not the only instance of death by mismanagement. "What really killed off Virtual I/O," he continues, "was the enormous amount of money they blew on marketing – massive advertising campaigns, huge stands at shows and 'first class' living for the marketing teams. They created an oversized infrastructure that was not supported by the sales they were able to achieve." Similarly, Atari's plans to work with UK company Virtuality on a VR headset for the Jaguar were scrapped when Atari started to fall apart. Not to be outdone, Virtuality self-destructed several months later (although the technology at the centre of the deal did eventually surface as 'DynoVisor' in Japan and in the US as Philips' moderately successful 'Scuba' headset).

Alongside these disastrous endeavours, larger companies such as Hasbro and Sega were also working on prototype HMDs – but none of them went to market, even though Hasbro invested \$57m into developing a VR console. In some ways, this reluctance is understandable; the HMD was beginning to look like a risky venture; there seemed to be no market for it in its current state, and consumers just didn't know what to do with it. Nothing underlined this more than the launch of Nintendo's Virtual Boy in July '95. Touted by creator Gunpei Yoki to be an important advance in videogame technology, it was to be one of the company's least successful ventures. Game over, in fact.

### Long live virtual reality

*"The single most important issue for the further deployment of VR experiences is not in the development of the hardware side of things, but in the development of the software. If we don't have compelling reasons to use VR, we won't."*

Sheldon Brown, associate professor Visual Arts, University of California, San Diego, 1999

But, of course, VR is not dead. It's not even sleeping. It's just that widescale understanding of the phrase is too blinkered to appreciate the advances being made. As **Bob Berry**, chief technical officer at ZeroKast Inc. in Japan, argues, "VR is here and has been for quite some time. I think my first VR experience was playing a MUD for 12 hours straight. Granted, not everyone can be so absorbed by a pure text medium, but talk about immersion and interaction! If we only define VR as wearing clunky head-mounted displays, full body suits and datagloves, we might just miss it all together. For all we know, Moore's Law might have us skip right over all of that and go straight into nano-swarms."

Indeed, although early fumbblings into consumer head-mounted hardware failed, that didn't stop computer game designers from attempting to replicate reality in their software. **Toby Simpson** at Cyberlife agrees with Berry: "VR is all about suspension of disbelief – the idea that you can forget that you're in a computer game, if only for a brief period. The easiest way of achieving this is to copy reality itself inside a machine. Construct an environment that looks real and feels real, and then populate that environment with a variety of systems – be they enemies, plants, animals, spaceships, whatever. Most of the modern videogames we play are therefore virtual realities in some way."

Simpson is correct, of course. The immersive 3D environments created in firstperson shoot 'em ups, for example, get incredibly close to many peoples' understanding of the term 'virtual reality'. On a basic level, the lack of onscreen character means there's nothing to separate the player from the action – you see events through your own eyes, rather than through the alienating presence of a Mario or a Lara Croft. Furthermore, the introduction of mouse control to give 360-degree head movement perfectly mimics natural human motion.

As technology improves, so games get closer to the immersive experience. The introduction of 3D graphics cards has allowed PC developers to play with things like environment mapping, realtime and coloured lighting, realistic shadows, etc, all of which add plausibility and depth to the game world. At the same time, the greater processor power offered by Pentium II systems has enabled designers to build games from the inside out, concentrating on true world elements like AI and physics – the very intestines of reality.

The Internet is also contributing to the dispersal of VR concepts. From William Gibson's idea of cyberspace, to VPL System's first ever complete consumer VR system, 'The RB2' (Reality Built For Two, designed specifically to enable two users to enter the same environment), the multiuser experience has always been a vital element of VR thought. Nowadays, not only do we get the short, sharp bursts of *Quake* action via thousands of dedicated servers, we

"VR is all about suspension of disbelief: the idea that you can forget that you're in a computer game, if only for a brief period.. Most of the modern videogames we play are therefore virtual realities in some way" **Toby Simpson**, Cyberlife

also get sustained graphical worlds like *Meridian 59* and *Ultima Online* – indeed, despite the lack of visual 'authenticity', these environments may be the closest technology can currently get to creating a synthetic reality.

And consoles are not being left behind, it's just that PlayStation/N64/Dreamcast games tend to explore facets of virtual reality more subtly. Beat 'em ups have furthered the computer representation of the human form more than any other realm (hence *'Virtual' Fighter*), while driving games like *Ridge Racer Type 4* construct intricate, beautifully realised

## BECOMING VIRTUAL

Fully immersive virtual reality may be years away, but current videogames are already edging toward the phenomema. Here are four key examples.

### UNREAL

Made revolutionary use of coloured lighting to enhance the game environment. Plus, the internet mode allows for transparent server traversal: you can walk through a teleporter and arrive in another world, housed on another server. This pre-guesses the work of ZeroKast, a company focused on persistent virtual world construction and VR consulting. "Our work involves the connectivity of heterogeneous environments (ie, the ability to connect a *Quake* world to an *Unreal*, to a *Half-Life* world, etc)," explains VP **Bob Berry**. Online VR is taking shape.



### R4 – RIDGE RACER TYPE 4

*R4* artists employ light, shade and intricate detail to create a world that borders on authenticity. Virtual environments will need to be as artistically refined as this. As Visual Arts authority professor **Sheldon Brown** argues, "interactivity has to do with how we understand dimensional space through perspective, lighting, texture-mapping and motion. The more refined these elements are, and the more [they] are determined by the intentions of the artist, the more cohesive the VR experience becomes." Art, it seems, still matters.



### SHENMUE

Yu Suzuki wants his ambitious RPG project to become indistinguishable from real-life experiences. As part of this, the game employs conversation between players and non-player characters – a step towards what some academics see as a major factor in the VR experience: actually talking to the game. **Philip A Bralich**, president of Ergo Linguistic Technologies, says, "One of the major sticking points to the spread of VR is the fact that you cannot really chat with characters." Using something like IBM's *ViaVoice* for ingame talk could be next...



### ULTIMA ONLINE

Multiuser online games like *Ultima Online* and *Meridian 59* perhaps get closer than anything else to virtual reality – they represent totally contained worlds where players can completely immerse themselves in alternative identities. Since *Ultima Online* was set up over a year ago, hundreds of guilds have been formed and dozens of ingame marriages have taken place. A new build entitled *The Second Age* recently added new landscapes and gameplay features as well as a user-friendly chat system. The future starts here.



### VIRTUAL DISNEY

You can tell there's money to be had in VR when big players like Disney get back into the game. The massive entertainment company is currently investing millions of dollars into its Disney Quest centres, the first of which opened last year in Disney World, Orlando. These massive indoor theme parks feature several 'virtual reality attractions' including a Virtual Jungle Cruise, Aladdin's Magic Carpet Ride and Hercules in the Underworld. The internal architecture is designed to encourage visitors to 'actually enter the story and become a part of it.' New centres are opening soon.



## VIRTUAL EVOLUTION

Many of the technological advances made by early virtual reality pioneers have survived into today's videogame industry. Indeed, certain peripherals and concepts may never have found their way into the console and PC hardware realms had they not been explored by simulation academics many years before. Here are three examples.

### 3D SOUND

**THEN** In 1985, NASA took on ex-Atari programmer Scott Fisher to head up the VIVED project after the departure of Mike McGreevy. Fisher wanted to create an aurally as well as visually immersive environment, and so commissioned Scott Foster, of audio co. Crystal River Engineering to produce a true 3D sound system. The result was Convolvotron, a 3D audio setup which allowed the simulation user to discern the direction from each specific sound emanated. Convolvotron represented a key breakthrough in the creation of a total sensory experience.

**NOW** Videogame developers are gradually getting to grips with 3D sound. Creative's Environmental Audio API (which is supported by the SoundBlaster Live! family of audio accelerators) is designed to help developers incorporate true 3D sound into their games, specifically 'to create a realistic sense of distance between the player and audio events.' Elsewhere, rival company Aureal has recently released the latest version of its own 3D audio standard, A3D. Even if headsets don't take off, 3D environmental sound is certain to become a key game feature.



Creative's 3D sound system. Audio reality



Videologic's Sonic Vortex 2 sound card

### FORCE FEEDBACK

**THEN** In 1976, Professor Frederick Brooks and several colleagues began work on a seminal force-feedback project humorously entitled Project G.R.O.P.E. The technology, developed initially at the Argonne National Lab for radioactive materials handling, and later at the University of North Carolina, was intended to allow scientists to touch and manipulate 'virtual' molecules in 3D simulation. Since then force-feedback has become an important part of high-end simulation – and an extremely expensive one. Force-feedback-capable glove controllers can cost up to \$40,000.

**NOW** Steadily pushing its way into the games market over the last three years, Microsoft's Sidewinder Force Feedback Pro joystick, and the Mad Katz steering wheel do go some way to emulating the resistance encountered by fighter pilots and racing drivers. Other simple haptic devices such as the N64 Rumble Pak and PlayStation Dual Shock controller have also provided players with another layer of sensory information, such as rough terrain in driving games, or the jolt of a bullet in *GoldenEye*. Perhaps the most innovative uses are to come.



Good vibrations: the N64 Rumble Pak



Sony soon adopted the rumble feature

### INTUITIVE CONTROL

**THEN** VPL Research, set up in 1984 by Jared Lainer (the man who invented the phrase 'virtual reality'), produced the DataGlove as one of the first commercial VR products. It was designed to meet the needs of virtual reality simulation creators who required an immersive means of manipulating objects and navigating within 3D environments. The glove used a magnetic sensor and fibre-optic cabling, allowing the computer to track the sim user's hand movement in virtual space. This incredibly intuitive device, adapted by various companies over the years, is now a standard in high-end VR.

**NOW** Not only has the videogame industry made many advances in the area of intuitive, immersive control, it has done so on a budget. As **Bob Berry** points out, 'A VPL superglove costs \$4,000, but it is hardly more advanced than an old Nintendo Powerglove which you can find on the Web for \$6.' More recently, the N64 analogue pad and Namco's many game-specific controllers draw the gamer closer to the action. As for firstperson shoot 'em ups, Microsoft has announced a more intuitive stick to replace mouse and keyboard control. Evolution is constant.



Time Crisis would have been lost without it



The N64 controller. A videogame milestone



Philips' Scuba headset – based on Virtuality technology – enjoyed moderate success. The electronics giant is rumoured to be working on a hi-res follow-up

urban landscapes. With Dreamcast's Internet capabilities, and the specifications of the next generation PlayStation, the lead into consumer VR could well come from dedicated games machines rather than the PC.

Ultimately, the home HMD market – flawed and volatile – failed its audience and scarred the reputation of VR. Vivality, in the boom years of the technology, 3D gaming was in its infancy, and consumers had no experience of moving about in 3D worlds. Now, however, by utilising constant advances in 3D technology, game developers have slowly introduced the public to the idea of immersive, simulated reality as a viable concept. It is through software, rather than hardware, that virtual reality has become viable again.

## Back to reality

Over the last 12 months, several huge consumer electronics companies have begun looking into HMD technology. Sony, for example, has its Glasstron range of personal LCD monitors, the latest of which – the PLM-S700 – was released in Japan last November. This incredibly lightweight setup is built around two 0.7-inch LCD screens, and, when hooked up to a video source or PC (via the usual monitor port), projects a single image at a perceived distance of 1.2 metres from the wearer. Boasting 1.5 million pixels per screen the PLM-S700 is capable of producing an 800x600 SVGA display – a clarity far in advance of the original consumer HMD units.

Japan is currently a virtual breeding ground for this sort of technology. Olympus realised Eyetrak, a personal monitor with comparable specs to an earlier Glasstron, last year and Canon has also released a headset aimed at the console and games PC market. Philips, too, is rumoured to be developing a follow-up to the Scuba headset, using much more advanced components.

Could this surge herald a renaissance for the home VR market? One thing is for sure: HMD technology is no longer in the hands of precarious entrepreneurial companies desperate to make money – it's in the hands of massive multinational corporations that can afford to play around with the technology for years before it begins to attract a mass audience.

Admittedly, apart from Canon, these companies do not currently have their eyes on the games market. The forerunner to the Glasstron PLM-S700 was bundled with Sony's DVD Player and was obviously intended for



Videogame peripheral designers have been eager to exploit the public's fascination with virtual reality. Hence, the NES PowerGlove (top) and Reality Quest's more recent PlayStation glove controller (above)



discreet film viewing, and although no one quite knows who the latest model is aimed at, at \$2,500 it certainly isn't gamers.

In fact, there is a potentially massive 'serious' market on the horizon: the wearable computer. Usually consisting of a small PC unit attached to a belt, a wrist-mounted keyboard and a head-mounted personal monitor (with see-through screen), these units have been around for a couple of years, but price, weight and a lack of processing power have restricted them to a small cybergeek userbase. Over the last few months, however, companies like Liquid Image and Xybernaut have brought out lighter, more powerful products – as **Tony Havelka**, president of Liquid Image points out "Current wearable computers that we offer are based upon the Cyrix MediaGX chip operating at 180MHz. They have 64Mb of RAM and a 3.2Gb hard drive, two Type II PC card slots, and a docking station. The entire system weighs 22 ounces and can operate on battery power for up to eight hours."

At the moment, wearables remain restricted to the professional sector. Customs officials, production-line inspectors and brokers on the stock exchange

"While on the surface it seems that we're doing 'serious' work in the wearable computing area, there are numerous technologies being created that will have direct crossover capabilities in the gaming market" **Tony Havelka, Liquid Image**

floor are all customers due to the fact that they can't stop, sit down and boot up a laptop, but need access to data quickly. However, society as a whole is becoming more mobile – laptops and palmtops now account for over 50 per cent of PC sales and it won't be long before workers find they need to keep in constant touch with the office even while walking between home and the workplace. (Plus, the good thing about wearable PCs is that you don't have to download data to a desktop PC when you get back to the office – the wearable is the desktop PC – you simply attach it to a normal monitor and keyboard.)

Wearable computers, then, could well represent the next phase in the communications revolution, and everyone wants to get in on it. No doubt Sony, Olympus and Canon have an eye on the market with their personal monitors, and other big fish are making more explicit plans. IBM, for example, is currently prototyping the VisionPad, a wearable computer believed to be based on an Intel 233MHz Pentium, complete with HMD and IBM's own ViaVoice voice dictation software. A launch is expected sometime this year.

But what does all this have to do with games? Simple. If wearable computers do become as popular as laptops – more successful, even – then dozens of massive companies are going to start producing high-quality SVGA personal monitors. However, the makers of these monitors would be foolish to restrict themselves to the mobile computing market: the entertainment software industry is expanding at an incredible rate, fuelled by consumer demand for 3D games. Realtime 3D is big business – that's why Intel recently invested \$24m in 3D graphics company Evans and Sutherland, why Microsoft continues its DirectX project, and why all the leading CAD companies are investing heavily in realtime 3D software developers – the first company to adapt its personal monitor for consumer VR use may just find itself in the lead with a massive new market.

And, importantly, all the facets are in place for home VR to work. As Vaughan suggests, "The principle difference between now and then is

## MOTION SICKNESS

One of the major barriers to the widescale consumer adoption of VR headsets in the early '90s was 'simulation sickness.' In short, VR made people feel ill.

There are a number of reasons for this, some technical, some physical. The former are easier to place, as **Ben Vaughan** points out, "Typically, low-end HMD manufacturers like Virtual I/O and Victormaxx used liquid tilt sensors – the liquid moves in the direction you tilt the sensor and this can be measured to show movement in the virtual environment. The problem is that they are inaccurate, slow (inducing lag) and suffer from 'slosh' – ie, the liquid moves one way, then sloshes back, affecting the screen image."

Lag (the delay between the user moving their head, and the image moving in synch) is perhaps the key problem here. A delay of just 50 milliseconds is enough to inform the brain that the image is lagging behind. The sensual disorientation this causes contributes heavily towards nausea. According to Vaughan, InterSense has made major advances in the tracking area. Vaughan says, "Eric Foxlin has studied inertial tracking systems at MIT and filed a patent that covered the use of drift correct inertial sensors for tracking heads and other similarly sized bodies. The products that are now built use a combination of accelerometers, gyros and magnetometers and a hell of a lot of clever maths to provide quick, interference-free tracking."

But what about the physical/psychological problems? There is a 'sensory rearrangement theory' which suggests that motion sickness while using VR is a result of conflicting messages reaching the brain from different senses. In other words, virtual reality confuses the brain in the same way as a bumpy sea journey, by misaligning what the organ sees and what it feels.

that optics and lens technology have advanced thanks to new materials and manufacturing processes; miniature hi-res panels have been developed and high performance inertial trackers are now available. On top of that, these companies have the financial and technical resources to develop and manufacture the products properly." Headsets are now light, hi-res and well-made. On paper, at least, it's all coming together.

Havelka concurs, "While on the surface it seems that we're doing 'serious' work in the wearable computing area, there are numerous technologies being created that will have direct crossover capabilities in the gaming market. One such technology is head-mounted display technology. We've created a lightweight (4oz) monocular display for wearable computing applications. It's based upon a 0.24-inch diagonal LCD display. The next generation of display is 0.50-inch in diagonal, but has a resolution of 1,280x1,024 and is full colour. By incorporating two of these screens into a headset, one for each eye, the gamer will be presented with an image possibly better than what they have on their current monitors. High quality, immersive gaming will be a reality for the average home user."

Indeed, Sony would already seem to be making moves in this direction. It is, for example, currently developing a Glasstron with stereoscopic capabilities – a major leap toward immersive VR. Furthermore, US-based tracking specialist InterSense has developed a product



3D graphics have revolutionised the videogame industry, and they are becoming more and more complex – as these screenshots from Sega's home console versions of *Virtua Racing* (top), *Daytona* (centre) and *Sega Rally 2* (above) attest. Is the next evolutionary step truly immersive virtual reality? Several massive electronics companies are hedging their bets

## LCD: RIP

All current laptops and personal display monitors use Liquid Crystal Display (LCD) screens. Unfortunately, this technology is expensive, mainly because it only has a manufacturing yield rate of around five per cent – for every 100 LCD displays made, 95 per cent have to be discarded. Such waste cannot be tolerated in the modern technology industry, of course, and several organisations are now working on alternatives. One example is Cambridge Display Technology. Last year the company announced its development of a screen using light-emitting polymers – or 'plastic that glows' as the setup is euphemistically referred to. Although in its infancy (currently only monochrome displays are possible), the technology has attracted the attention of giants like Intel and Seiko-Epson. Not only are LEP screens cheaper to manufacture than LCD equivalents, but they can also be moulded into any shape, making them perfect for use in VR headsets. LEP televisions are expected within five years, and if the technology does drastically reduce the price of small hi-res displays, it could find its way into future Glasstron or Eye-Trek units. If HMDs were no more expensive than joysticks, would there finally be a mass market?



CDT's LEP display. The next step is full colour

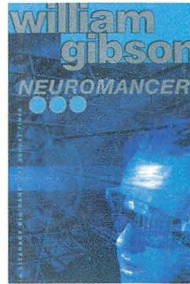

William Gibson's classic 1984 cyberpunk novel *Neuromancer* coined the term 'cyberspace'. It describes the process of exploring an advanced kind of virtual reality Internet which users actually project their consciousness into via dermatrodes attached to the forehead

professional sector. As PR manager **Betsy Rogers** told **Edge**, "We are pursuing development contracts with early adopters within the aerospace, defence, medical and industrial sectors, and have delivered prototype displays to the US Army, the US Airforce, the US Navy, Boeing, Saab, and Ericsson/Saab Avionics. We also have a development contract with the Wallace-Kettering Neuroscience Institute to develop a head-wearable display for use in image-guided surgery applications."

At the moment, the technology is far too expensive to move across to the mass consumer market – mostly because of the laser technology currently being employed. "In order for the price to come down, the components need to get smaller and cheaper, particularly the light sources," explains Rogers. "While we currently use red laser diodes, green and blue laser diodes don't exist yet. We're using gas lasers for blue and green in our prototypes, which cost thousands of dollars. The equivalent laser diodes would cost just a few dollars apiece – and eventually just a few cents."

In two to three years time, then, when blue and green LEDs become available (and companies begin working with them), Microvision has plans for several products, including a mobile phone with VRD monitor for face-to-face communication and an entertainment platform. "Players could wear VRD-enabled eyeglasses that beam the game directly onto their retinas to create a virtual reality world rendered in full detail," suggests Rogers. The possibilities are staggering.

called Intertrax – a small, lightweight head tracking device which fits onto the Glasstron. As Vaughan explains, "The tracker connects to the PC through the serial port and communicates with the PC using RS232 data. The tracker firmware includes two modes: in mouse emulation mode it'll work with pretty much any software in two degrees of freedom. To get full use (3DOF) of the tracker, it needs either a driver or direct integration." Although all PC games will work with Intertrax through mouse emulation (first-person shoot 'em ups naturally work best), it's currently difficult for developers to exploit the full 3DOF feature. If Microsoft were to adapt its DirectInput API to recognise headtracking technology, however, things would be much simpler.

## An eye on the future

Even if the wearable computer fails to take off, there are other technologies waiting in the wings to offer a home to VR. Last year the Human Interface Technology Lab at Washington University won the 1998 *Discover* magazine Technological Innovation Award, thanks to its virtual retinal display project. A VRD unit currently uses a combination of laser and light-emitting diodes (LEDs) to shoot a single stream of pixels directly onto the user's retina. As the beam scans across the eye the user's visual system interprets the signal as a coherent image – just as it would while watching a television. The size of the 'virtual monitor' is adaptable, as is the distance it appears from the user.

Optical technologies company Microvision has recently licensed the technology for commercial use, and is currently showing off prototypes to the



Sony's PLM-5700 (left) and the InterSense headtracker (above) together provide a hi-res virtual reality image that smoothly tracks head movement

## One day, all this will be VR

So the components of virtual reality, as the early pioneers dreamt of it, are real – and they are converging. Software developers are creating incredibly realistic 3D environments with real-world physics, immersive sound and involving storylines; hardware companies are working on HMDs and virtual retinal displays, and the Internet is spawning dozens of sustained game worlds where people have created virtual lives, virtual friendships, even virtual love affairs.

Perhaps the future of VR is a mix of all these strands – an online world, like *Meridian 59*, but with the visuals of *Half-Life*, viewed through an HMD. But even HMDs are passé as far as cyberculture goes. In *Neuromancer* William Gibson saw a world where computer users jacked straight into an international comms network,

doing away with a thirdparty computer interface altogether. Science fiction? For now, perhaps. But things are changing fast – as Bery asserts, “The neural implant is the Holy Grail for Gibsonian cyberpunks. But much like the notion of a species dependant on computer technology, it’s already here. Scientists have already utilised a neural implant as a treatment for some forms of epilepsy. The day when we are able to ‘jack in’ to our computers is closer than most people realise.” Just bear that in mind while you’re slaving over the specs of Sony’s next generation PlayStation.

Despite all the positivity in the industry, however, a large question mark still hangs over consumer VR. What if, regardless of technological advances and despite amazing 3D software, people simply don’t want it? After all, it’s currently possible to buy a full VR system for around £1,500 – if you know where to look. As Bob Berry explains, “MetaByte offers a great package that includes a Wicked3D Voodoo2 SLI rig, eyeSCREAM Stereoscopic glasses, and an incredible driver that lets you boost to unheard-of resolutions when using a 3Dfx chip. If you put that together with a large viewing display, fast machine, 3D surround sound and a comfortable input device I think you have home VR for under \$3,000. As my friend Scot Refsland said, ‘The technology is there. People need to catch up!’”



David Cronenburg’s ‘eXistenZ’ is the latest movie to toy with VR themes. Players hook up to games via a spinal jack – a concept similar to the Dermatroids in ‘Neuromancer’. Will VR only become a ‘must have’ when players can jack straight into the game experience?

“Through the six years I spent witnessing people using HMDs, I would estimate that just a quarter of users really understood how the headset worked and truly enjoyed the software” Graeme Williams, Virtuality

But maybe people don’t want to catch up. Psygnosis designer **Graeme Williams**, who worked at Virtuality throughout constant updates of the technology, is unconvinced: “Through the six years I spent witnessing people using HMDs, I would estimate that just a quarter of users really understood how the headset worked and truly enjoyed the software. Then there was a middle 50 per cent who, after several minutes of assisted experimentation, would finally twig what it was all about. Finally, the last quarter of people would never respond to coaching with the machines. They just couldn’t make the leap from all the hardware to the virtual realities they were trying to be immersed in. I put this down to their reluctance to detach themselves from their real-world surroundings and a mild technophobia.”

Indeed, many people find the experience of sitting in front of a monitor in a darkened room playing *Half-Life* immersive and frightening enough, so why bother forking out for a headset? **Chris Hecker** at US developer Definition Six is another non-believer: “VR failed because no one’s come up with a way to make money in an ‘immersive environment’ that doesn’t involve shooting somebody! As for home VR, people don’t like to put junk like headsets and gloves on their bodies to interact with their computers, even for videogames.”

However, ten years ago many industry pundits couldn’t have foreseen the enormous growth of the Internet or the fact that a huge percentage of homes would have PCs. Similarly, the 3D graphics card business sprung out of nowhere, but the public embraced it and it now dominates the computer games industry. The technophobia Virtuality experienced two years ago is a dying prejudice. Perhaps all it will take for home VR to lift off is just one killer app or a company like IBM bundling a HMD with their PCs. After all, in the computer industry, making something ‘free’ is always the best way to get people to on board.



Will typical PC users one day wear their computers? Companies such as Xbernaut and Liquid Image certainly believe so. The Xbernaut Mobile Assistant (top) is built around a 233MHz CPU and features a 4.3Gb removeable hard drive. Liquid Image’s wearable (above) weighs just 22oz. This market could generate interest in HMDs and consequently VR

## VIRTUAL RETINAL DISPLAY

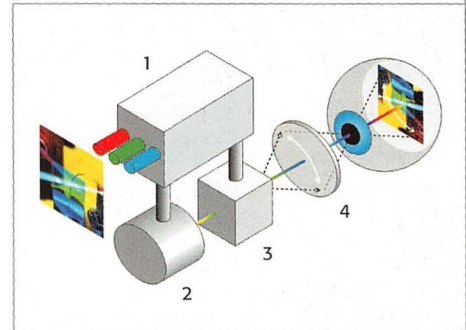

Microvision’s Virtual Retinal Display was originally developed at the University of Washington’s Human Interface Technology Lab. The device essentially transmits electronic information directly into the user’s eye, rather than via a screen of any kind. As Microvision ([www.mvis.com](http://www.mvis.com)) explains, “The device conveys the image by scanning an electrically encoded beam of light through the pupil to the retina, simulating receptors on the back of the eye. The user has the impression of viewing a high-quality video image an arm’s length away.” Currently hugely expensive, the development of cheaper light-emitting technologies could bring Virtual Retinal Displays into the consumer market within five years.

### KEY

1. Drive Electronics: Receive the image from its source (video, PC, etc) and process it
2. Light sources: Combine red, green and blue to colour each pixel appropriately. The light sources apparently operate at a very low intensity so they pose no danger to the eye
3. Scanners: Horizontal and vertical scanners move the light source across the eye to create the image
4. Optics: These elements project the scanning beam of light through the pupil and on to the retina

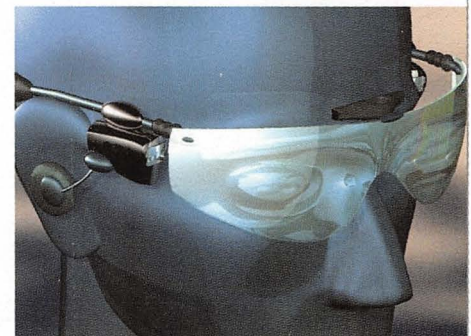

Microvision’s mock-up of a personal monitor employing Virtual Retinal Display technology. This may be a reality within three years



# RORY MCLEISH DESIGN

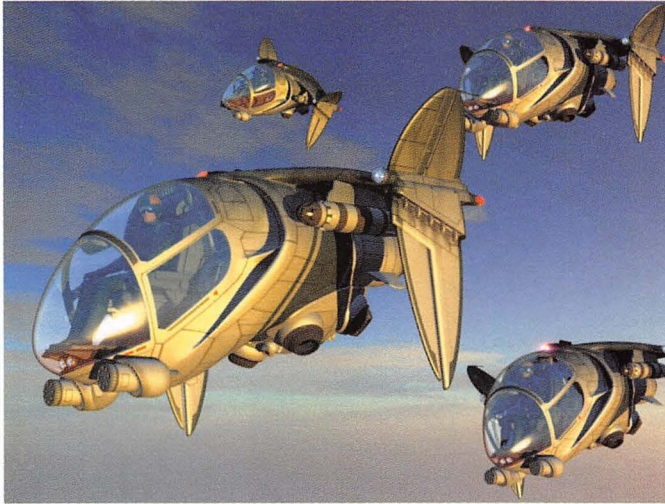

LOCATIONS • CHARACTERS • VEHICLES

Proof of Concept and fully-textured finished CG Models for Broadcasting, Motion Pictures and the Games Industry. Models developed from sketches or written briefs. Fast.



TEL • FAX  
01423 507865

WEBSITE



www.mcleish-design.com



Machine	£Call
Controllers	£34.99
Visual Memory	£29.99
Gun - 25 <sup>th</sup> March	£Call
Steering Wheel	£56.99
RGB Scarts/S VHS	£Call
Rumble Pak	£Call



House of the Dead 2	£59.99
HOTD 2 with Gun	£Call
Monaco Grand Prix	£49.99
Marvel vs Capcom	£59.99
Super Speed Racing	£54.99
AeroDancing	£49.99
Psychic Force 2012	£54.99

**PART EXCHANGE WELCOME ON ALL DREAMCAST PRODUCTS**



### US/JAP NEW

Silent Hill (US/Jap)	£49.99
Final Fantasy 8 (Jap)	£62.99
Pocket Station	£36.99
King of Fighters 98 (Jap)	£49.99

### US/JAP NEW

Tenchu 2 (Jap)	£49.99
Ridge Racer 4 (US)	£49.99
Syphon Filter (US)	£49.99
Ace Combat 3 (Jap)	£49.99

### US/JAP NEW

Perfect Dark	Call for latest info	Quake 2 (US)	£Call
Win Back (Jap)	£57.99	ShadowGate	£Call
Hybrid Heaven	£Call	Castlevania 64	£49.99



**USED IMPORT N64 GAMES FROM £12.00. CALL FOR MORE INFO**



### JAPANESE NEW

StreetFighter Zero 3	£Call	Biohazard 2	Call for more details
Xmen vs StreetFighter	£44.99	Marvel vs StreetFighter + RAM	£59.99
Radiant Silver Gun	£47.99	Vampire Savior	£44.99
		Dead or Alive	£48.99

**JAP SATURN SPECIALISTS. USED GAMES IN STOCK FROM £5.00**



[www.next-gen.co.uk](http://www.next-gen.co.uk)



**Tel: 01252 678 728**



# SYSTEM V VIDEOSYSTEM

## TOP FLIGHT POLE POSITION ARTISTS & SENIOR ARTISTS

**PlayStation 2 / Dreamcast / PC**

Central Manchester location,  
small & experienced team,  
low pressure environment.

*High profile titles - major licenses*

**— Senior Artists:**

2-4 yrs games experience; schedule management.

**30-35K + bonuses**

**— Artists:**

2 yrs games experience; low-poly modelling, texturing.

**20-30K + bonuses**

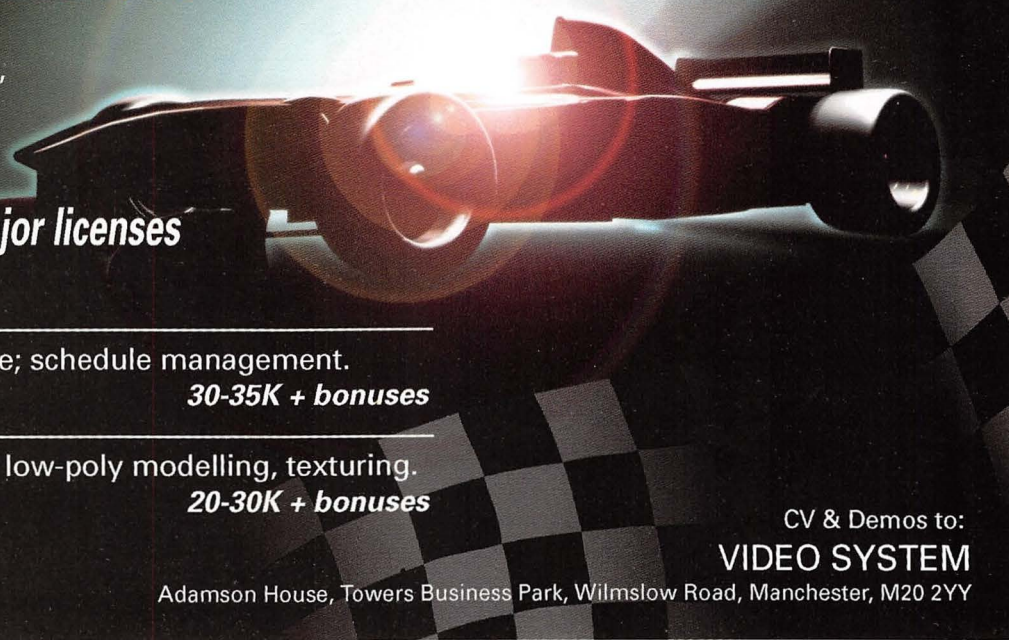

CV & Demos to:  
**VIDEO SYSTEM**

Adamson House, Towers Business Park, Wilmslow Road, Manchester, M20 2YY

# TESTSCREEN

The definitive monthly assessment of the world's latest videogames

## Where now for Sega?

**S**ony's next generation PlayStation announcement last month sent shockwaves through the development community, leaving even the most verbose cynic struggling for words. The resulting impact was everything SCEI had hoped for, of course, but the reality is nevertheless unavoidable: the implications of this forthcoming 128bit system are massive. In theory, videogaming is about to enter a whole new dimension, with Sony currently seemingly way ahead of the rest of the field.

Sega may have looked ahead when developing its Dreamcast system. But Sony looked at technology that didn't exist 'off the shelf', and forged ahead.

Having recovered from the initial shock, cynics are now busy spreading their wisdom on the Internet, with tales of concern regarding Sony's ability to launch its new machine at a reasonable price point. It's a fair point, obviously, but you can't help thinking that you don't sell 50 million PlayStations worldwide without knowing what you're doing.

On paper at least, then, Dreamcast looks significantly inferior to the PlayStation's successor, but only a fool would claim that Sega has already lost. In Japan, gamers remain excited at the prospect of forthcoming titles for their 128bit Sega system and there's a genuine buzz about all things Dreamcast,

which is more than can be said about the N64 and its escalating fight to maintain shelf space in Akihabara's finest videogame emporiums. With the next PlayStation still some time away, Sega has enough time to build up a strong and loyal domestic user base – a task that would be easy with a consistent string of quality titles.

More importantly, perhaps, the company needs to focus strongly on the European launch. In many respects, Sega is in an enviable position. Naturally, the marketing machine needs to be maintained with a constant supply of propaganda-based oil, but the launch line-up must be right. This is absolutely crucial. There is enough time to fine-tune *Virtua Fighter 3tb*, *Sonic Adventure* and *Sega Rally 2* before the machine arrives in Europe. Add in the formidable *Power Stone* and *Resident Evil: Code Veronica*, *Shenmue*, *Soul Calibur*, among others, and Dreamcast could in theory launch here with ten to 15 'must have' titles – an unprecedented feat in videogaming history and something capable of converting even the most hardened Sony fan. It would also send out reassuring echoes of a company prepared to take its audience seriously – a crucial consideration.

It doesn't really matter how many polygons a console can throw around. Only consistent, strong software support can ensure commercial success.



Despite the potential of Sony's NGPS, Dreamcast's launch in Europe with quality titles such as (from left) *Sonic Adventure*, *Power Stone* and *Bio-Hazard* could still secure a chance for Sega

**Edge** evaluates games on a scale of ten, where five naturally represents the middle value. A game receiving a 'seven out of ten', for example, is a highly competent title with noticeable flaws but which should still appeal to a considerable range of players – naturally more so to those who favour the title's particular genre. It does, after all, score two points above average and should therefore not be considered as such.

**Edge's** rating system is fair, progressive and balanced. An average game deserves an average mark – not, as many believe, seven out of ten.

## Videogames on the Edge

### This month's hot softs...



#### Kingpin (PC) Xantrix

Securing the prize for least 'PC' PC game of the year, *Kingpin* has stunned pundits with its expletive-laden audio and bloody combat. Effing great.



#### Wild Metal Country (PC) DMA

Tank-hunting season is in full swing as **Edge** furthers its quest to be the most dangerous beast in the universe. The fun you can have with teleport shells...



#### Pop 'n' Music (PS) Konami

Forget your Joypad and invest in the appropriate controller. It doesn't make this surprisingly addictive game any easier, but you'll look less stupid trying it out.



#### Rollcage (PS) Psygnosis

Occasionally frustrating it may be, but this can offer some genuinely thrilling gaming moments. Which is more than can be said for many 'new-breed' racers.

## Index

### Aliens Vs Predator

page 70

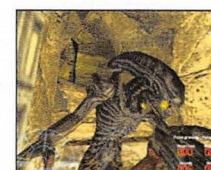

### Blue Stinger

page 72

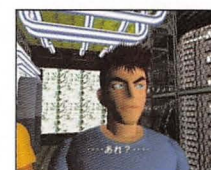

### Aero Dancing

page 74

### X-Wing Alliance

page 76



### Redline

page 78

### Um Jammer Lammy

page 79

### Duke Nukem: Zero Hour

page 80

### The House of the Dead 2

page 81

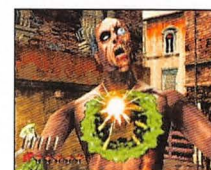

# ALIENS Vs PREDATOR

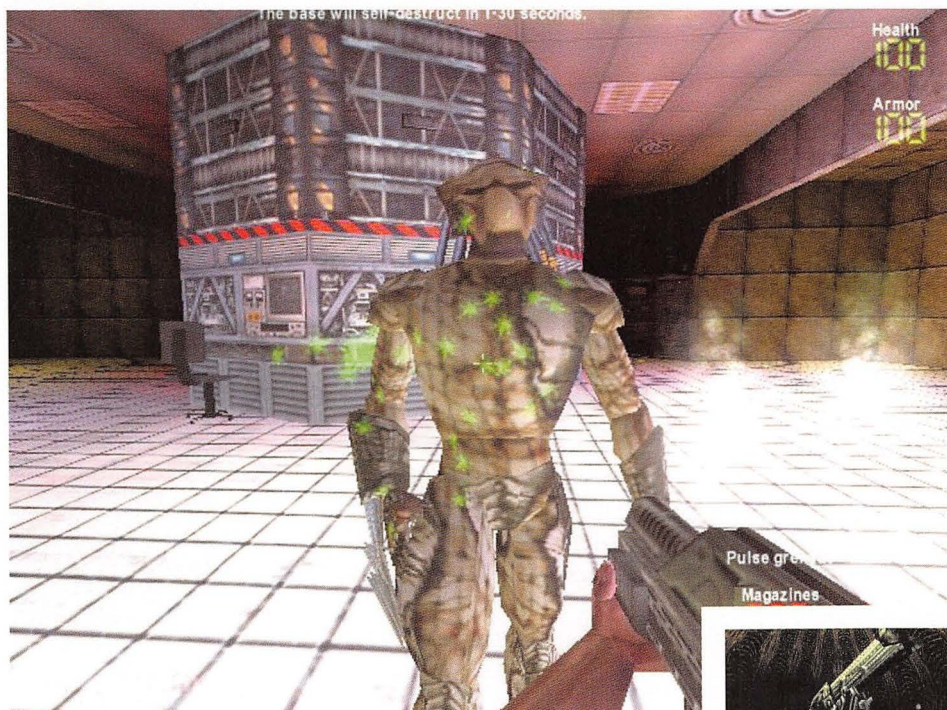

While playing as the marine, the cloaking system can help you to get close to targets, but true to character, the Predator doesn't depend on sight alone

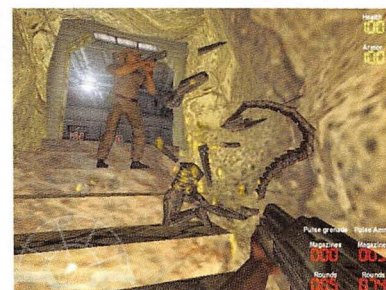
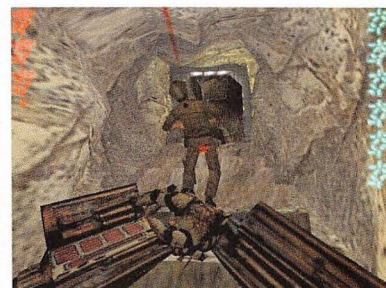

Later levels have you fighting alongside fellow marines (right) – but most allies come to a sticky end

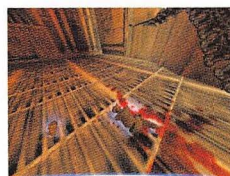
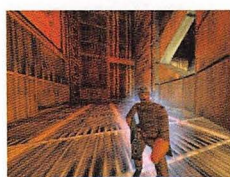

In a genre rife with violence, *AVP* ranks as the most bloodthirsty yet. Body parts are realistically torn away while gore splatters against all surfaces

At first glance, *Aliens Vs Predator* would appear to be little more than another *Quake* derivative cloaked with familiar movie-manufactured finery. But while it undoubtedly works within the familiar confines of a familiar genre, few could have expected British team Rebellion to inject it with so many fresh ideas and such a genuine feel for the 'Alien' and 'Predator' movies. It may not be as technically revolutionary as the almighty *Half-Life*, but by portraying the battle between three very different lifeforms – human marines also figure prominently – from each perspective, it delivers an intense and highly graphic conflict to rival even its big-screen inspiration.

Those of you who remember the ill-fated Atari Jaguar may recall Rebellion's earlier attempt at bringing two of the best movie monsters into one gaming arena, an idea previously explored in the Dark Horse graphic novels. Clearly, much has changed

since those days, and while the three-way battle between man, biomechanoid alien and savage predator remains central to the gameplay, this looks, feels and plays very differently. Making fair use of current PC technology, it creates a unique visual style where blood of three hues splatters against floors, walls, and ceilings with shocking regularity, and where each of the three creatures is exquisitely animated. The Predator stomps around with real weight and menace, marines peer cautiously into the darkness, and aliens belt along at a truly frightening pace, scaling walls and ceilings in an unnerving and strategically crucial way. Even a creature's death throes are painstakingly handled, with body parts

skittering off in all directions, heads bouncing down stairwells, and blood spurting from gaping wounds.

Playing the role of the marine is where gamers will feel on most familiar ground. In this mode, the story has the player stranded after a training mission. Progress inevitably involves much button pushing, use of lifts, and collection of extra medical supplies and better weapons. But even though such elements are strictly by numbers, even here the licence has been used to elevate the proceedings to another level. Several scenes recall classic moments from the movies, the aliens moving with the ferocity of those in 'Alien 3', and the close combat – complete with pulsing radar – mirroring the heated battles from 'Aliens'. Even face-huggers, and

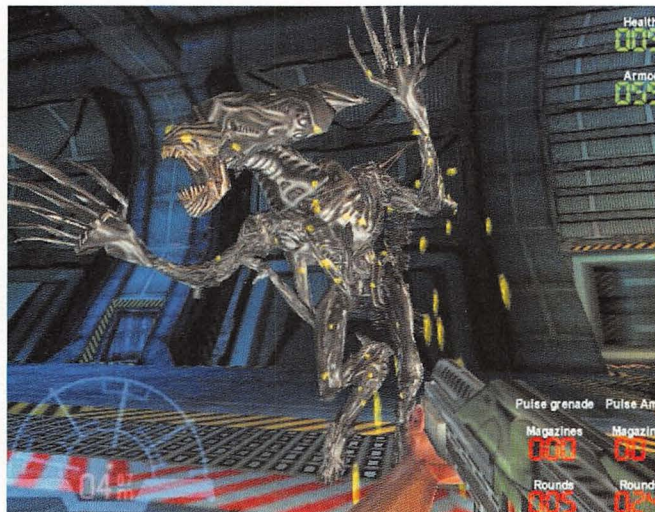
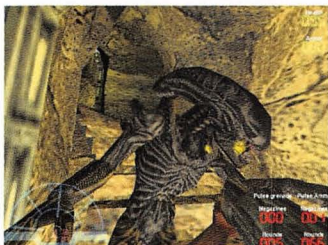

While one of the most effective translations to small screen yet, the licence limits the creature types available, although there's still room for variation, including high-powered aliens (top left) and the queen herself (right)

flame-throwers to combat them, are included, while the finale goes all out to recreate the hangar showdown with an alien queen. Needless to say, the answer lies with that airlock...

Playing as the Predator, the differences in weapons and view behaviour have the greatest impact, although being able to jump and fall great distances does have its uses. It's also possible to switch the focus to different parts of the colour spectrum, making tracking prey much easier. The Predator's helmet also features a zoom function, while the shoulder cannon and disc weapons make use of that famous triangulating targeting system. In addition, enemies can be skewered, shot at with a pistol, or simply sliced with wristblades, a cloaking device making it possible to get up close without detection. The cloaking system isn't infallible, though, as movement and bright light reduce its effectiveness. In addition, actions such as opening doors will obviously attract attention, while it's largely futile when confronting the aliens as they can 'see' through it anyway – they use pheromones to track prey.

It's in the hardened reptilian shell of the alien that things get really

inventive. All of those properties that make them so exhilarating to fight against – most notably that surface-clinging ability – make them utterly 'alien' to control. As the manual notes, this creature doesn't have any weapons, it *is* a weapon. This means attacks are limited to claw and tail swipes, or jaw crushes, any damage inflicted rewarding the alien with energy top-ups. But while the alien is surprisingly vulnerable to attack, and has to get dangerously close to its enemies to kill them, its speed and

three races, that ensures *AVP* succeeds where so many other movie spin-offs fail. Granted, the tie-in also means there are a limited number of creature types to fight against. But, with six main missions for each creature, an extra 15 bonus levels further exploring the three-way battle (and introducing new elements such as jetpacks and grappling hooks), and the unique angle it adds to the multiplayer modes, such limitations are forgivable.

Equally, while *AVP* lacks the glossiness of its peers (*Unreal*, *Half-*

Running around **upside down or along walls** is intensely **confusing** for some time, but with practice it transforms **the whole firstperson shoot 'em up** experience

agility give it a real edge. A jump function makes it possible to pounce on enemies, or leap four stories up, while that clinging ability makes a mockery of gravity. Running around upside down or along walls is intensely confusing for some time, but with practice it transforms the whole firstperson shoot 'em up experience.

It's this mode of play, plus the way the game fully explores the interaction possibilities between the

*Life*, etc) – featuring more modestly designed locations, simpler AI coding, and a control system lacking in precision – the fabulously horrific, tense, and uniquely skewed action will doubtless be enough to make it a firm favourite with those PC gamers who possess an insatiable appetite for firstperson thrills. 

Edge rating:

Eight out of ten

Format: PC

Publisher: Fox Interactive

Developer: Rebellion

Price: £35

Release: Out now



The Alien's vision is enhanced by pheromone detection, while the Predator can switch to alternative spectral bandwidths – both useful visual advantages

# BLUE STINGER



Letting loose with the napalm gun is undoubtedly good to watch, but it's really no more involving than a fireworks display. Visual pyrotechnics may be *Blue Stinger's* *raison d'être*, but on Dreamcast fine graphics should be a given



By blowing away the targets in this arcade attraction, Elliot can use the prize to gain a secret pass code from the little girl nearby. It's as easy as A, B and then C

The first of 1999's new wave of Japanese action adventures, Climax Graphics' *Blue Stinger*, was originally scheduled to appear in late '98. As with many ambitious Dreamcast titles, it was no great surprise when this one quietly slid by its release date. The drip-feeding of increasingly impressive screenshots kept hopes high for *Stinger's* quality.

Heavily indebted to Capcom's seminal *Bio-Hazard* series, *Blue Stinger* offers a sprawling world to explore, patterned with simple conundrums to inhibit your progress and a vast arsenal of weapons with which to eliminate multiple foes. The game's curious plot is relayed via some of the worst scripting yet to

crawl out of Japan, plummeting beyond the realms of humour into sheer risibility. That the characters' lips don't even vaguely synch to their speech only adds to the negative impression.

Controlling a pair of unlikely heroes, one Elliot G Ballade and Captain Dogs, your mission is to discover what has happened to a secret military testbase after it is hit by a stray meteorite. It soon becomes apparent that disaster has – quite literally – struck, with the base deserted save for a handful of survivors and a motley collection of half-man-half-monsters.

Unsurprisingly, locating the survivors results in being given items which aid your progress. The alien

creatures must be blown apart, after which a bizarre fountain of gold coins erupts from their corpses. This cash can then be spent at various vending machines around the base to buy everything from cans of cola to a 'super bazooka'.

*Blue Stinger's* high points come almost exclusively from buying and trying the successively more extreme weaponry on offer. As with all the game's artwork, explosive effects from items such as the napalm gun are exceptional, although the artists' palette would have benefited from being a shade more reserved. Scenery is detailed, although it's nothing more than stage dressing, and interactivity is sadly reduced by only being able to pick up whichever items are twinkling on the screen. Very 1992.

It could well be that *Blue Stinger* is portentous of action adventures yet to come on the new superconsoles.

Alien creatures must be blown apart, after which a bizarre fountain of gold coins erupts from their corpses. This cash can then be spent at various vending machines



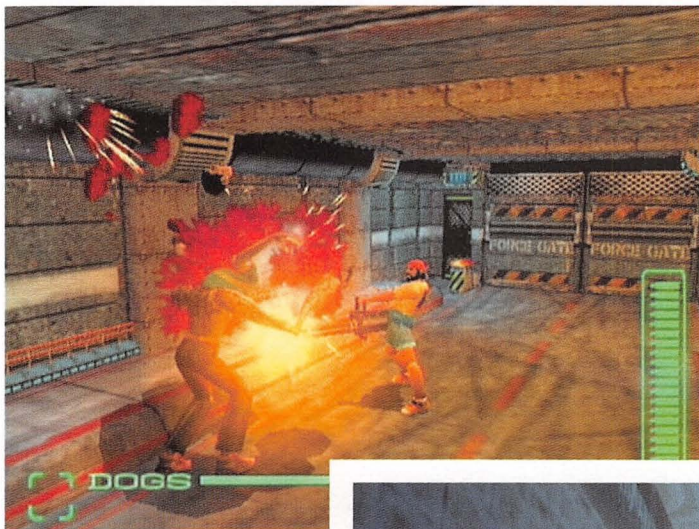

Going for a dip (top right) should be a simple operation, but the control system defies all logic



Defeating foes becomes somewhat easier once you've obtained the axe, although when confronted by two at a time, combat is simply frustrating

Clearly a huge amount of effort has been expended by Climax Graphics on creating a detailed backdrop for the action, but if something had to give, to ship *Stinger* within budget, clearly it was the gameplay. Simple details that many thought were a thing of the past, such as the characters running headlong into walls – then carrying on their running animations – are a rife.

More detrimental still is the combination of a hyperactive camera and an occasionally infuriating control system, particularly when Elliot has to swim through sections. That Miyamoto-san's designers taught the world how to swim in 3D nearly four years ago makes the fault even less tolerable. And in the curious realms of *Blue Stinger*, humans seemingly have no inclination to float.

Similarly annoying is the ingame camera. Instead of taking up position in the corner of a room, or simply tracking behind the character – as in *Mario* – it swoops and flits around the action, often resting in the most bizarre positions. Edge can only assume that the programmers' intention was to replicate the kooky angles of *Bio-Hazard* in a real 3D environment.

Despite its numerous faults, though, *Stinger's* exploratory nature makes it hard to guess what's coming next. There are several fine plot moments, such as having to defrost a giant freezer before the characters themselves freeze, which help counter the many minus points. However, the puzzles that must be solved to advance the story are complex only through a combination of obscurity and Japanese text. The western version – if one arrives – will be a walkover, so linear is your progress.

Although Climax Graphics has obviously strived to create a rival to

Capcom's horrific adventures, it has, ultimately, failed. It's not a case of the title being buried under the weight of expectations, more that it simply feels conceptually under-developed. In 1999 such poor animation and weak camera work, coupled with a sub-B-movie plot (backed by the most overblown musical score of recent memory), are simply unacceptable. Sega now needs *Bio-Hazard: Code Veronica* to impress more than ever.



Edge rating:

Five out of ten

Format: Dreamcast

Publisher: Sega Enterprises

Developer: Climax Graphics

Price: ¥5,800 (£30)

Release: Out now (Japan)



*Blue Stinger* does have its moments, such as when you're blasted across a chasm after triggering this explosion

# AERO DANCING

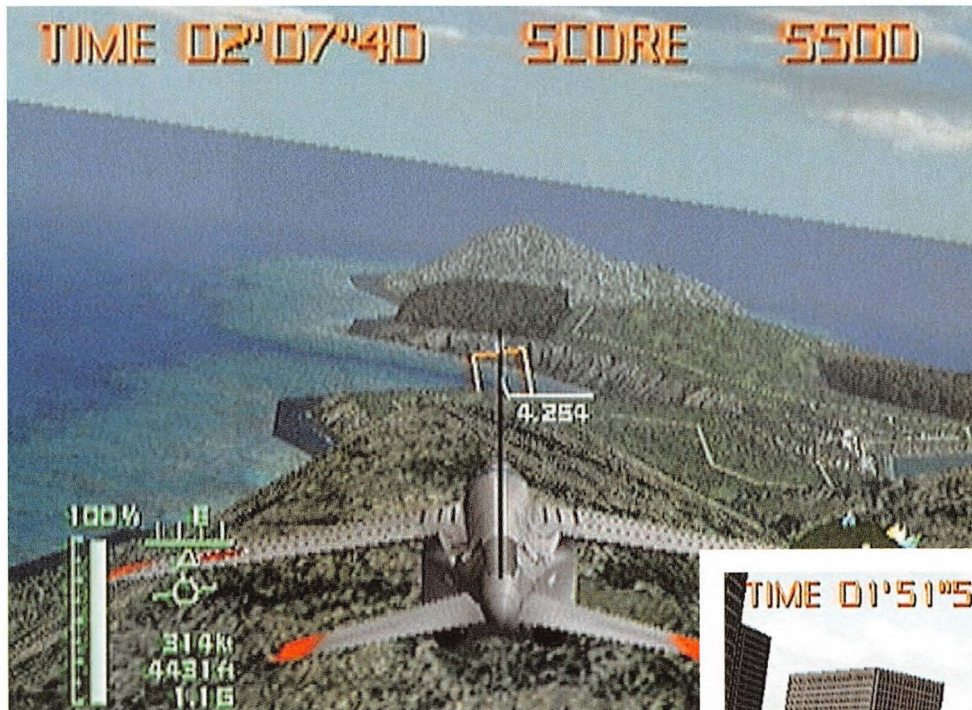

Three ingame views are available: cockpit, close chase (above), and far chase. In the cockpit, the display obliterates the screen, making flying very difficult

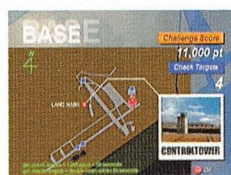

Blue Impulse flights start with a lengthy mission briefing in Japanese (top). The only clues to your mission objectives are the speed and degrees figures...

That flight sims don't work on consoles is one of gaming's universally accepted rules. The lack of analogue control, processing power, even a lack of buttons with which to accurately control a plane, have all meant that for serious enthusiasts, the PC is the only credible option. Now that Sega's new machine has overcome at least two of those stumbling blocks, *Aero Dancing* is intended to become the first of its kind on a console. Yet, despite its promising debut (see E68) and graphic finery, it ultimately fails.

For anyone who doubts that cultural differences exist as much in games as in any other form of media, *Aero Dancing* should be prescribed entertainment. The difference of approach that Japanese and western players bring to games is reflected in the open structure of this title. The three main play modes (Blue Impulse Mission, Sky Mission Attack and Free Flight) require you to enjoy the *Aero*



The peculiar pacing is most noticeable in the city section, where even at 200mph and 50ft from the ground there is a disappointing lack of speed

*Dancing* experience over and above the objective tasks thrown at you by the structure of the gameplay.

As an example, the game's Sky Mission Attack mode consists of eight missions with *PilotWings*-style objective rings to fly through, spread out over a large area. Points are awarded for navigating the bonus rings scattered along the way, as well the fastest mission time. However, the difficulty curve is set so shallow and the missions themselves are so easy to complete, that it's possible to waltz

through the majority of this section of the game at the first attempt. That isn't to say that there isn't massive scope for improving your scores and refining flight strategy, it's just that, with the exception of a high-score table, there is very little motivation to repeat and practice sections.

Taking another area of the game, it's hard to see how western players raised on perpetual conflict scenarios are really going to clasp formation flying to their bosoms. For a far throw from the deodorising qualities



Crucially, the blue rings are your main objectives in the Sky Mission Attack mode. An auto-targeting system and radar enable you to navigate more easily



The demanding multiplayer mode (right) requires formation flying on one screen



suggested by its title, Blue Impulse is in fact Japan's premier aeronautical display team, and this part of the game concentrates on training players to take part in some of their routines. This translates to a short series of briefings, miniature flights and debriefings, to form a surprisingly effective tutorial on some of the main techniques involved in flying. It's only when this area of the game has been mastered that the singlescreen multiplayer missions should be attempted. These involve close-formation flying, with a break in formation leading to the premature, *Micro Machines*-esque end to the mission. It sounds an unworkable concept which, in practice, is exactly what it turns out to be.

If *Aero Dancing* was in itself a vibrant flight simulator – capable of

challenging the best that the PC has to offer – its rather weak internal structure might be forgiven. The inevitable problem, though, is that the game falls between the absolute simulation required by dedicated fans, and the easy arcade thrills delivered

The **difficulty curve** is set so shallow and the **missions themselves** are so **easy to complete**, that it's possible to **waltz through** the majority of this section of the game at the first attempt

by most console games. On one hand the analogue control and simple throttle are not going to impress anyone trained in the use of the full joystick, throttle lever and rudder pedals setup. On the other (and despite the fact that the planes on offer in the game are some of the fastest in the world), there is a worrying lack of speed which lends a relaxed, treacly pace to what should be some white-knuckle flying. It's possible to fly under bridge spans less than 100ft high at 350 knots, and yet doing so gives no more impression of speed across the ground than cruising at an altitude of half a mile.

At best, *Aero Dancing* is a brave attempt at a style of game more

suited to the PC. At worst, it's a competent graphics engine with an afternoon's worth of game attached. For all its smooth analogue handling and largely glitch-free graphics, there just isn't enough content to provoke any serious long-term interest.

If it was taken back into the studio and redesigned to include at least quadruple the number of missions and incorporate the smooth difficulty curve of *PilotWings*, then even given its sedate pace *Aero Dancing* might have stood a better chance. As it is, few gamers should hold their breath for a UK launch.



Edge rating:

Four out of ten



You'll receive instructions in the finer arts of take-off and landing



While the graphics engine is solid with little clipping, there is a disappointing lack of ground detail on all of the flight arenas

Format: Dreamcast  
 Publisher: Sega  
 Developer: CRI  
 Price: ¥5,800 (£30)  
 Release: Out now (Japan)

# X-WING ALLIANCE



Familiar imagery and situations abound, including a final battle against the Empire's second Death Star. Fighting against the Tie Fighters is particularly challenging. They may not be heavily armoured, but move extremely fast

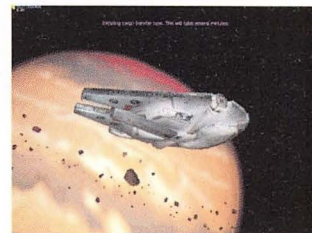
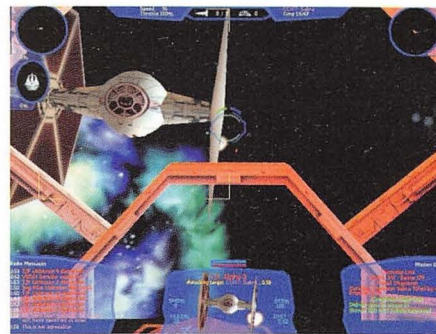

While *X-Wing Alliance* will most likely benefit from the hyperbole surrounding the forthcoming 'Star Wars: The Phantom Menace' movie, there's a strong sense that a game based around the original trilogy couldn't really have been released any later. Attention has already turned to the next two 'Star Wars' games, leaving this latest addition to the *X-Wing* series exposed as little more than an update of an existing formula.

Happily for *X-Wing Alliance*, however, the formula is one that works, and has finally come of age here. For, while previous LucasArts titles have had to rely on good game mechanics and that priceless licence rather than cutting-edge coding, *Alliance* brings a more contemporary air to the battle between the Empire and the Rebellion, with coloured lighting and higher detail modelling vastly improving the experience.

The story also impresses, neatly working alongside the film scripts in its telling of a trader family drawn into the conflict. It's a well-conceived idea that provides two distinct chapters; novices learn the basics of flight while trading, gradually coming to blows more frequently until they join the Rebel Alliance and get to fly a whole new set of craft. Best of all, though, the designers have finally woken up to what gamers really want from a 'Star

Wars' game, bringing key events into the plot. There's an opportunity to fly the Millennium Falcon, with the tale culminating in truly epic style with a run on the second Death Star above Endor.

The gameplay is familiar enough, treating the licence with such gravity that piloting the various craft takes on the form of a simulation, each possessing its own complex features and handling physics. Even a multi-button joystick isn't enough to cover the many functions needed to fly any of these vehicles, with a bewildering range of throttle, targeting, communication, docking, and multifunction display toggles to consider. It's rather alarming to discover that the control reference chart supplied in the box stretches over five pages, some controls requiring use of the Shift or Ctrl keys – clearly, this is not a title that will



Deep-space scenes are filled with background art and a glut of other craft. Electricity crackles and sparks fly when heavy damage is inflicted



Hi-res textures and detailed vehicle models convey a great sense of scale

ever be ported to a console. Such a dedication to pseudo-realism may well please some PC gamers, but to **Edge** it seems absurd that the 'Star Wars' universe has been modelled to this degree. Flight and battle sequences on the big screen are always brisk, action-led affairs, so it's rather ironic that the PC interpretation should try so hard to get away from straight shoot 'em up action.

That said, it's an approach that hasn't hurt *X-Wing Alliance's* predecessors at all. And this proves to be just as adept at adding colour to the gameplay as it is to those visuals. The oneplayer mode builds up the sense of camaraderie brilliantly, over 6,000 lines of dialogue ensuring every mission features a generous helping

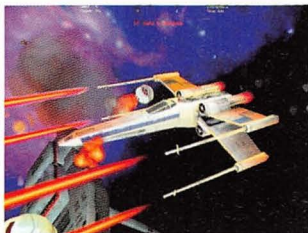

Improved ingame lighting makes battle scenes more convincing



Early missions require you to cooperate with family members, providing support and rescuing them if plans go disastrously wrong. The level of graphical detail extends to models of the player and his robot co-pilot (right)

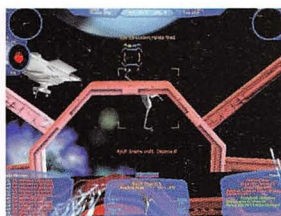

The designers have **finally woken up** to what gamers really want from a 'Star Wars' game. **There's an opportunity** to fly the **Millennium Falcon**, with the tale culminating in truly epic style

of character interplay. The missions themselves prove most satisfying, rarely relying on clichéd ideas.

*Alliance* also finds the series finally achieving a fine balance between its solo and multiplayer variations, with that strong narrative complemented by a strong range of network, serial link and Internet game modes. There's the ability to race other players using the Pilot Proving Grounds, as well as going into battle in the various predesigned or custom skirmish missions. Here, the choice of 20 or so familiar 'Star Wars' spacecraft really comes to the fore, with up to 32 players fighting in teams, battling in deep space, asteroid fields or mined areas.

Despite the misgivings about the simulation-like treatment of what is essentially escapist sci-fi nonsense, *X-Wing Alliance* is a powerful evocation of that classic milieu. Recreating the sights and sounds of the movies with rare skill, it pulls out all the stops to ensure the age of the first trilogy ends in real style. It's not a great evolution by any means, but as a refinement of an already well-loved game style it easily exceeds expectations. A nation of would-be Luke Skywalkers can breathe a sigh of relief: the Force is still with them.



Edge rating:

Eight out of ten

Format: PC

Publisher: LucasArts

Developer: Totally Games

Price: £35

Release: Out now



Early missions gradually introduce the threat of the Empire, although players who don't act promptly can soon find themselves in hot water

# REDLINE

Format: PC

Publisher: Electronic Arts

Developer: Accolade

Price: £40

Release: Out now

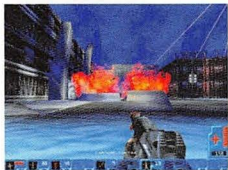

**Redline perks up a little once you switch to on-foot action. Particularly satisfying are the visceral charms of the buzz saw (above)**



**Redline endeavours to meld two proven game styles – which is why it merits attention within these pages. The execution hardly matches the ambition, though**

**T**he danger with attempting two things at once is that you often simultaneously succeed at neither – a feat consummately achieved by Accolade with this vainglorious attempt to fuse *Quake* with *Carmageddon*. Aided by a lumbering post-apocalyptic storyline, this hybrid tries to elicit the cars 'n' guns excitement of 'Mad Max', but fails as its genre donors reject each other.

This compatibility flaw manifests itself most clearly in the level design. Large, open arenas facilitate the car wars sequences, where armoured buggies circle each other amid a crossfire of bonnet-mounted rockets and anyone on foot is dogmeat. Where maze-like tunnel sections mark the pedestrian interludes, you adopt a more traditional firstperson pose,



**Even with an accelerator card the graphics are simply woeful**

fending off assailants with the usual selection of shotguns, grenades and rocket launchers.

The effect is to divide *Redline* into two separate games that bear little relation to each other. Rather than using the dualistic approach to multiply the player's options throughout the game, Accolade has settled for a predictable rut of car section followed by gun section followed by car section, and so on.

Such problems would be forgiven if either sub-game delivered, but in comparison to the best the PC has to offer, will leave you cold.

The driving side, though easy to master, suffers from simplistic handling. The differences between the various vehicles' acceleration and agility is negligible, so there's little thrill whenever you jump into a new model. What's more, the onboard targeting system is incredibly frustrating, while the weapon effects are barely worth the effort anyway.

The firstperson shooter element is much more enjoyable, featuring deft ideas such as the transforming gun, which can be reconfigured, Swiss Army knife-style, into different weapons including a buzz saw, rocket launcher and sniper rifle.

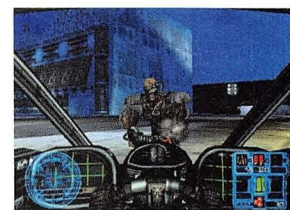
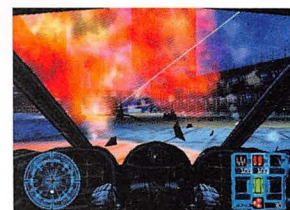

**Fatally, the in-car sequences suffer from anodyne handling and a poor control system**

Yet, once you're on foot, *Redline* demonstrates how tragically bereft of innovation and raw spectacle it truly is. The 3D engine is weak, featuring a bland mish-mash of uninspiring architecture and dismal colours, only outdone by the primitive nature of the texturing. Add to this the unconvincing animation, enemy-lite levels, linear and unimaginative mission objectives, and you have a game that, despite touting two of the most bankable commodities in gaming, somehow conspires to be less than the sum of its parts.

Edge rating:

Four out of ten

# UM JAMMER LAMMY



If your guitar skills aren't up to scratch the music and scenery begins to distort

You have to admire the surreal absurdity of the *Um Jammer Lammy* world. The situations the eponymous Lammy (guitarist in the band MilkCan) finds herself in as you help her reach the town's concert venue in time for her band's gig are not only ludicrously diverse, but probably only conceptualised with the assistance from rather strong – and possibly illegal – chemicals. The whole experience is a psychedelic voyage into the unexpected; there's little way of knowing where the next challenge is going to take the likeable songstress.

Unfortunately, like its predecessor *Parappa the Rapper*, the experience is not a particularly long one, with most gamers probably able to reach the final stage in a couple of sittings. Unlike *Parappa*, however, SCEI has



Reach the 'cool' ranking and play with Hendrix-like abandon



The twoplayer cooperative mode (above left) and its competitive equivalent (above right) go some way to promoting welcome longevity

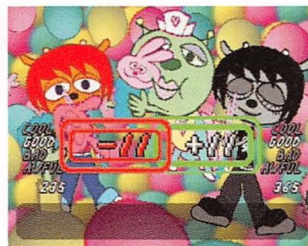

instigated a couple of twoplayer options to inject a little extra life into the experience. You and a friend (or the CPU, should you fail to persuade someone that this is actually a good game despite the lack of polygons) can take part in engagingly cooperative or competitive rounds, which open up progressively alongside advancements made in the oneplayer game.

The musical repertoire may be a far cry from the former game's obsession with rap, delving into the realm of funk, pop, rock, and even the unclassifiable, but *Jammer Lammy's* principle and structure remain identical: you have to match your musical opponent note for word before progression is granted. The reason for the different musical content lies in the fact that rather than singing her way through the

levels like *Parappa*, Lammy relies on her guitar skills as an effective way of repositing her adversaries' lines. Not only does this enable a more eclectic collection of rockin' tunes to be included, but it also means that effects such as distortion and wah-wah pedals (rewards for successfully completing stages) can be used to add a little variety to the melodic extravaganza.

Ultimately, just like *Parappa* and *Bust A Move*, *Um Jammer Lammy* cannot hope to match the depth found in most of the more established genres. Nevertheless, it remains an entertaining, occasionally tempting, and altogether mind-boggling alternative for those more naturally drawn to fighting and driving games.

Edge rating:

Six out of ten

Format: PlayStation

Publisher: SCEI

Developer: In-house

Price: ¥5,800 (£30)

Release: Out now (Japan)



The cut-scenes linking one musical challenge to the next contain wonderfully bizarre elements as well as Rodney Greenblat's superb characters

# DUKE NUKEM: ZERO HOUR

Format: Nintendo 64

Publisher: GT Interactive

Developer: Eurocom

Price: £40

Release: May



**Zero Hour takes in a variety of locales, from outer space to Victorian England**

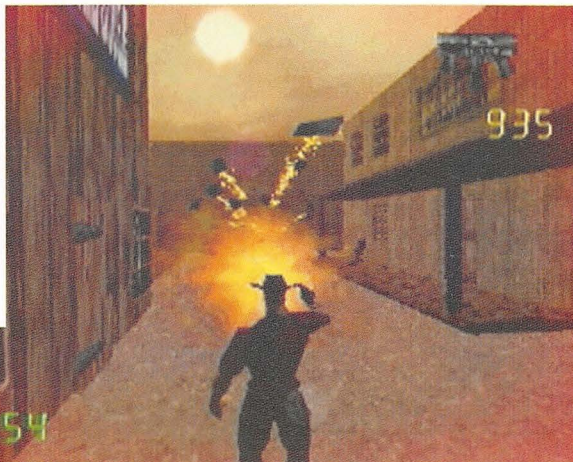

**The game features a snazzy line in poster art – the 'original' Turok features here (left), while much of the heavy artillery is borrowed from Turok 2**



**While Jack the Ripper does the rounds in Whitechapel, Duke is waylaid by the zombies that shuffle out of the fog (centre)**

If nothing else, the mildly diverting *Time to Kill* (7/10, £64) proved that the *Duke Nukem* series could quite comfortably function in thirdperson, being geared more towards *Doom* than *Tomb Raider*.

It's somewhat ironic, then, that Eurocom (which has spent a large proportion of its time on the N64 converting age-old PC and arcade titles like *Hexen*, *Mortal Kombat Trilogy* and the original *Duke Nukem*) should opt not to convert *Time to Kill*, but to build up its thirdperson *Duke* adventure almost entirely from scratch. Admittedly, around half of the level ideas have been carried across, but *Zero Hour* is a very different game, not least because *TTK*'s awkward and unconvincing platforming has been completely discarded. This new version is something more akin to the traditional *Duke* games.

Certainly, as action commences among the towering skyscrapers and neon glow of the city, it's difficult not to recall the opening level of the original *Duke Nukem*. This is merely a gentle introduction, however, as *Zero Hour* quickly hots up. As in *Time to Kill*, Duke is plucked from one point in

history and placed in another, leading the Expansion Pak-led visuals to play host to a series of dazzlingly diverse environments, including the Wild West, medieval Britain, outer space and an N64-specific, and purposely fogged, Victorian England, where Jack the Ripper is playing havoc among the lovely ladies of Whitehall.

The 3D camera is so effective it makes moving around completely problem free. When Duke slides up against a wall, for example, his head fades out and the game switches to firstperson, eschewing the need for a frustrating *Tomb Raider*-style camera adjustment. Getting to grips with *Zero Hour* is laudable, but more than that, it's a mindlessly enjoyable romp. With weaponry straight from Turok's own rifle cabinet – including a shotgun that can blow off individual limbs – and armies of, admittedly fairly cretinous, enemies. It's not so much the depth of the challenge as the length. Without doubt, there's no subtlety but, then,

with his pernicious one-liners (of which they are *many* new examples herein) and unshakeable shades-and-vest combination, Duke was never really concerned with acumen.

Added to the arsenal is a solid multiplayer game set across 13 arenas, of which at least half are excellent. As a deathmatch, it feels steadier and more convincing than in *Turok 2*, but never threatens to topple *GoldenEye*'s fourplayer head-to-head. That said, the arenas are intelligently mapped, with almost every one working in a tightly structured circle, minimising aimless wandering and maximising the use of freeze guns, pipe bombs and sniper rifles.

Which leaves *Zero Hour* as an undemanding but affecting hybrid of *Tomb Raider* and *Turok 2*, and one that confirms Eurocom as a developer to watch out for.



Edge rating:

Seven out of ten



# THE HOUSE OF THE DEAD 2



Much of *THOTD2* is utterly gruesome – arms, heads, chests and other zombie body parts can be blown apart in glorious Naomi-faithful quality

The problem with lightgun games, particularly when they happen to be direct coin-op translations, is that they're not designed for extended play, which makes them unsuitable for today's depth-hungry console gamers. Such experiences are more at home in the environment of the contemporary arcade. Yet, *The House of the Dead 2* makes a significant attempt at offering an impressive dose of longevity, mainly through the use of various alternate routes through its levels, which means that even after extensive play it's possible to happen across a hitherto undiscovered alleyway, pass through a secret passage, or even discover a room you haven't visited before. It's a question of your performance, of course, and while some pivotal moments may lead to handy shortcuts offering less zombie resistance, others can make life a little harder.

Of course, had Sega delivered merely a direct conversion of its enjoyable horror coin-op, this would have been a disappointing title. But, regardless of the fact that this conversion equals its Naomi-powered bigger brother with apparent ease,

both in graphics and sound quality, Sega has lumped in a bundle of extras. An 'original' mode allows you to select two bonus items (from a list featuring those attained in the arcade game) in order to help you on your turbulent journey. It's a structure that works surprisingly well and it's highly likely that you'll find yourself playing this on a more regular basis than the arcade mode.

Also exclusive to the DC are ten training missions which, although a little harsh in their level of difficulty (depending on how far away from your television you sit, of course), at least have the advantage of turning the arcade mode into a comparatively easy experience.

Naturally, you can use the standard joypad (complete with sight onscreen) – the analogue thumbstick providing surprisingly effective results – although for true arcade-recreation purposes, only Sega's specifically designed gun will do. The ergonomic, futuristic-looking white plastic unit fulfils its function with aplomb, and with a Puru-Puru Pak attached, makes some attempt at providing recoil.

*The House of the Dead 2* may never glue you to a TV for hours on

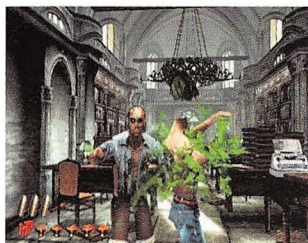
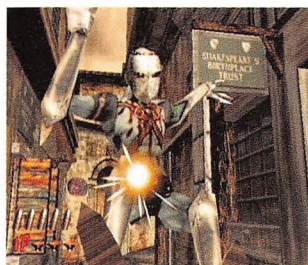

end, but it does offer a faithful recreation of a coin-op (sparkling graphics and all) that's still relatively new to the arcade scene.

In some respects this is the quintessential videogame: easily accessible, rewarding, and heavy on style. Come to the party expecting no more than instant thrills and you'll enjoy every minute.



Edge rating:

Seven out of ten

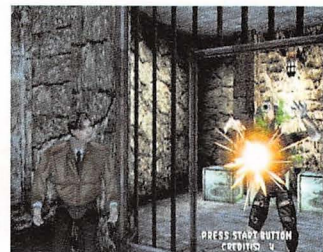

Throughout the game you'll encounter individuals requiring your help. Hesitate (or miss) and you won't get potentially helpful items in return

Format: Dreamcast

Publisher: Sega

Developer: In-house

Price: ¥5,800 (£30)

Release: Out now (Japan)



In addition to the ten training missions (three of which are shown above) Dreamcast *THOTD2* also lets you practice against any of its end-of-level bosses

**SN Systems: Seeking IDE solutions**

**B**ristol-based SN Systems Software has a good relationship with Sony. Very good, in fact, having generated the SDevTC development kit that ships to every existing PlayStation developer (see News, E70). With the next generation Sony console waiting in the wings, the company – headed up by directors **Andy Beveridge** and **Martin Day** – is already hard at work creating a fresh set of programming tools to smooth the complexities of creating 16-million-polygon games. **Edge** caught up with Beveridge to discover more...

**Edge: What is SN Systems' key skill?**

**AB:** SN Systems is always about fast turnaround in development. Our first product was an assembler which was several hundred times faster than anything else out there. We want to get the development cycle down as short as possible, and one of the best ways to do that is incremental linking. It's something Microsoft has been doing for quite a few years, but to do it you need to have pretty good control over the way the build goes, so we need use our own linker.

**Edge: Is that something you're working on right now?**

**AB:** That's something we will be working on this year – it's not going to be in the first release, it's a longer-term plan. We're aiming to have something working internally for May. Initially, we've just got to get the Win32 version of the GNU compiler together, and have our own backend assembler and linker just to give us control over the file formats and a slight edge on speed. We'll be bundling that with our integrated development environment [IDE] and debugger. The whole point of the IDE, really, is to host the debugger. The IDE does contain a text editor and a graphical build manager, but a big point of the environment – because that's where developers spend an awful lot of their time – is debugging.

**Edge: What are the specific challenges of creating an IDE for the next generation PlayStation?**

**AB:** We've got to provide debugging facilities not just for the main CPU but for the vector units [VU] as well. Debugging those units is not nice – they're subject to all sorts of pipeline 'gotchas', so you have to be very careful with them.

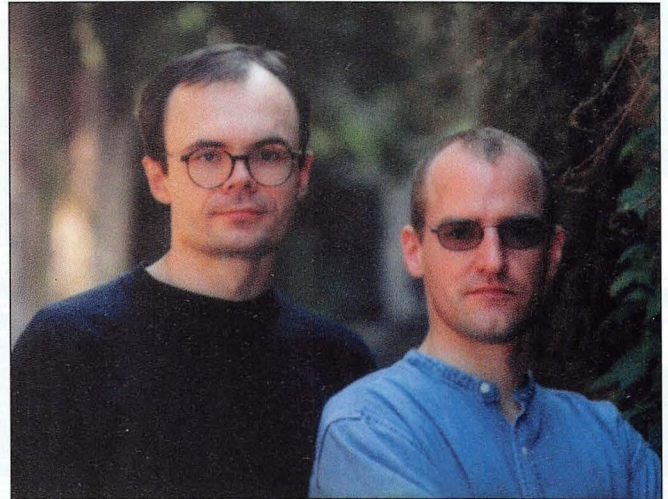

Directors **Martin Day** (left) and **Andy Beveridge** (right) are busy facing up to the challenge of creating an IDE for Sony's next generation PlayStation... but it's largely a debugger's life

**Edge: Is that due to having such a high throughput?**

**AB:** And because it's not a general purpose processor. It's specifically aimed at the graphical functions and the 3D functions; it has to perform the floating-point math. It's more like a DSP than a regular CPU. It has a rather odd instruction set and a very streamlined pipeline, but the result is that the way the pipeline is used is critical. Sony's solution to this is to provide a simulator for the VU. The problem with that is that it's not real time – there's no substitute for running your code on the real thing.

**Edge: So how long have you been aware of the next generation PlayStation and its challenges?**

**AB:** We've had full English paper specs – thorough specs of how all the chips work together – since November '98.



**WorkStation**

**W**hen **Edge** visited Sweden-based Digital Illusions, it simply couldn't pass by the perpetually cheery **Olof Gustafsson**, musician and sound effects artist responsible for the atmospheric music on all of the company's titles to date (*Pinball Dreams* and *Pinball Fantasies*, to name but two), who is currently composing for *Rally Masters*

**Bank of sexy synths** "The main sound department, where nearly all the sounds that are used in a song are produced and programmed"

**Texas Instruments Speak'n'Spell** "This is a speaking language learning box from the late-'70s. I'm still learning the English language, you know, haha"

**Main computer system** "This is a PC stuffed with juicy sound equipment. It's the heart of the system"

**Essential kit** "These bits and pieces help out with the final mix of a song. It's good to have a few friends around"



Members of the development community (sane or otherwise) are invited to email WorkStation submissions to [edge@futurenet.co.uk](mailto:edge@futurenet.co.uk)

**Hulking great metal-clad box** "A good ol' tape recorder, for making copies of my music to send to grandma"

**Cherry-red keyboard** "This synthesiser is one of my sweethearts, not just because of its extremely good looks, but for its quirky bass sounds"

**Prehistoric computer** "An old relic Macintosh. It's only used to edit PlayStation sounds and for making sounds for PlayStation games"



## The trials of a start-up developer: part nine

After co-founding Lionhead Studios with Peter Molyneux, Demis Hassabis set up his own development house, Elixir Studios. This month the steadily growing team relocates to altogether loftier heights...

### Moving on up

"Having finally signed the deal with Eidos, we could now take possession of our new office just in time for the New Year. We'd been stuck

in a serviced office in Cricklewood for six months and we were ready for a change of scenery – any scenery in fact. 'The Cave' had served us well, but you can only work without windows for so long.

We'd decided that we wanted to be based in Camden, in North London. It's an unusual place, unlike the rest of London, and has a very distinctive vibe. Imagine a chunk of Glastonbury permanently based in London and you'll know what I mean (without the mud, thankfully). There's a great energy to the area and it's slightly weird at the edges, so we thought it was somewhere we could fit in. Unfortunately, there's a serious lack of good office space and Joe had spent the autumn trawling the area for something decent, without much luck. Just before Christmas, he finally found something.

## "We seem to be in breach of the law that dictates 'thou shall not have a fun job'"

The new office is set back from the road, between Camden High Street and an adjoining road, two minutes' walk from the tube station. Whereas the last place was about 800 square foot, this is 3,000. In other words, there are 12 of us in an office for 30 or 40 people. All of which means a couple of desks huddled in the corner of an aircraft hangar. We've temporarily resolved this by creating a basketball court at one end. With stripped wooden floorboards and skylights, the contrast with the last place couldn't be greater. The morning I took everyone to the office for the first time was a great moment. I really took pleasure from seeing the excitement on peoples' faces. It was a taste of what we're working towards.

The building is owned and shared with the Variety Club, a charitable organisation. We got very excited when we heard that of their 30 employees, 20 or so were women. Middle-aged women, as it turned out, which was a bit of a disappointment. I think they're a little bit scared of us. It reminds me of a story that used to run in the comic *The Eagle*, called 'The Thirteenth Floor', which involved an elevator and a door to another world. Our version of this involves a twin-set-and-pearls type

accidentally stumbling upon a dark stairway leading to a shadowy hallway. Walking in, peering through the gloom, she sees 12 blokes cheering another as he attempts to climb from one side of the office to the other along one of the rafters. It's not the Variety Club, she realises, as she edges nervously towards the door. I suspect they think we're up to something vaguely subversive

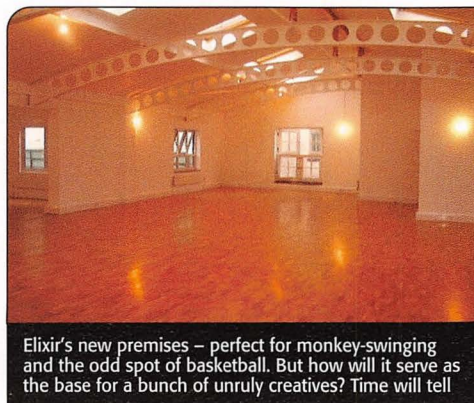

Elixir's new premises – perfect for monkey-swinging and the odd spot of basketball. But how will it serve as the base for a bunch of unruly creatives? Time will tell

or possibly worse. Of course, if we were programming spreadsheets or doing something dull we'd instantly be 'respectable'. We seem to be in breach of the law that dictates 'Thou shall not have a fun job.'

We've been adding people to the team at a steady rate.

Unfortunately, that's only been about one every two months. The industry as a whole is undergoing a period of tremendous growth and now there simply aren't many talented people left! We've added two more people in the last few months, both of whom are female – which in this industry is a rare thing. I was hoping this might have a knock-on effect on overall office standards of personal hygiene, to no avail, but then perhaps some things in this industry really are sacred. Sue Chapman's job is as office manager/mother hen and having her on board has really helped the running of the place. I was a little concerned that she might find our humour too 'robust', but was relieved to discover that her command of schoolboy innuendo and downright filth is as good as the rest of us. Our other new

recruit, Vicky Mann, is a programmer with a difference, having taken a degree in psychology. Our initial games will use a lot of artificial intelligence, and having her experience will, I hope, give us some really interesting insights into this area.

The next few months are a critical time for us. The time for delivering will shortly be upon us and, not surprisingly, we've got our noses to the grindstone. Over the next few months or so we'll be showing a prototype of our first game to the press. It's an anxious time for us right now and the nights seem to be getting longer. Tim and Dave appear to be enjoying themselves so much that they've decided to live here. Those cool autumnal *Starcraft* sessions have become a thing of the past. Nothing in life is ever guaranteed when you're doing something creative. Everyone who does something like this has to passionately believe that it's going to be great, otherwise they won't be able to do it. But you've also got to be objective and critical about your own work. If you aren't, then you run the risk of producing something ill-conceived like 'Manilow sings Sinatra' or 'The Avengers' – wonderfully self-indulgent, but creatively and

commercially pants. You can't let this scare you off (the challenge, that is, not Barry Manilow), but you've got to be duly respectful. When the time comes, I'll be taking you through the game in detail and describing everyone's role in this process. In the meantime, you must excuse me, as another one of our neighbours seems to have wandered accidentally into development hell!"



## Edge moves

Programmers, artists, engineers, producers, animators, project managers – they're all essential to the industry, and they all read **Edge**. The following pages carry a phenomenal variety of jobs for graduates, professionals and any other interested parties who think they could make it in the videogame scene. Apply within...

# 3 REASONS NOT TO COME TO AMSTERDAM

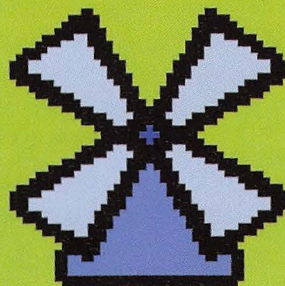
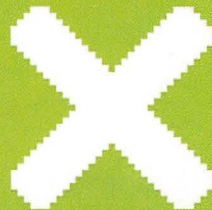
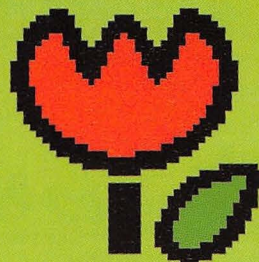

## ALTERNATIVELY...



Well, that's only if you are...

A Network Programmer with C++ skills and affinity with R&D.

Or a Graphic Artist. All-round and experienced with 3D Studio Max and DeluxePaint. 2 Years of industry experience modelling low-polygon characters and environments as well as 8 bit texturing skills make you the right person for this job.

Or a capable Level Designer/Script Coder with C++ and level building knowledge and the right creative attitude.

Send your CV and examples on PC media or VHS to Marlies Tan at...



**Formula Game Development, Herengracht 280**  
**1016 BX Amsterdam, The Netherlands** <http://www.formula.nl>

**FORMULA**  
game development

# CYBA3

Presents

a

## DISTANCE LEARNING

Training Course

for

Games & Modelling

in

3D Studio MAX R2.5

and

Adobe Photoshop & Premier

Fact: In 1998  
over 50% of OUR students went on to full time JOBS  
in the industry

Technology Centre, Technology Drive, Grange Road,  
Batley, West Yorkshire WF17 6ER  
Tel: 01924 500999 e-mail: cyba3@compuserve.com

**ARBOUR**  
APPOINTMENTS LTD



### HAPPY 1<sup>ST</sup> BIRTHDAY

Arbour Appointments Ltd. is proud to be celebrating its First Birthday on 1 May 1999!!!

- We deal with numerous Blue Chip companies and have hundreds of positions available. Many placed exclusively with us and advertised nowhere else.
- We deal in sectors such as: Aerospace, Automotive, Consumer, Control, Entertainment, Games, Leisure, Telecomms and many others.
- We need creative and motivated Software and Hardware Engineers now!

#### SENIOR PROGRAMMER

South East Salary to £30,000  
A successful games company requires someone with at least 12 months experience and solid core skills in C/C++, you must have experience of a wide range of areas, including sound, graphics, menu systems etc. Ref: E71/374

#### GRAPHIC DESIGNER

West Midlands Salary to £25,000  
To work within a new team developing characters, animations and game backdrops. You will ideally have a showreel developed in 3D Studio Max. Photoshop experience ideal. Any knowledge of Maya also a benefit. Ref: E71/118

#### HARDWARE DESIGN ENGINEER

Berkshire Salary to £35,000  
This digital video effects company requires a graduate with experience of high-speed digital design (to 80MHz), schematic entry and firmware experience (preferably VHDL). Analogue design experience desirable. Ref: E71/394

#### HARDWARE ENGINEERS

North Salary £34,000  
Positions exist at all levels for graduates with high-speed digital and embedded microprocessor design skills. Knowledge of any of the following a definite advantage: MPEG, video, audio, DVD or digital signal processing. Ref: E71/127

#### SOFTWARE ENGINEERS

North West Salary £32,000  
This company works at the cutting edge of broadcast technology and requires a number of C/C++ programmers. Any experience of real-time embedded systems, video/audio codecs or algorithms would be an advantage. Ref: E71/126

#### PLAYSTATION PROGRAMMERS (x2)

South East £Negotiable  
Two positions exist within this established and well respected company for experienced PlayStation programmers. Ideally you will have at least one published, successful title to your name. Ref: E71/425

### Free Service for Candidates - Very Low Company Rates

Send your CV, quoting Ref, to:  
Arbour Appointments Ltd.  
The Granary, High Street, Wombourne  
West Midlands WV5 9DN

Fax your CV 24 hours: (01902) 326465  
Telephone Jules on: (01902) 326460  
E-mail your CV: jules@arbour.co.uk  
Register at: www.arbour.co.uk

# Datascope

GAMES PEOPLE

## Programmers & Engineers

- PSX Programmer, Var. games Cleveland; £High. Contractors welc. REF: 823
- Junior PC Programmer, Sim game W London; £22k + bonus REF: 818
- 3D Programmer, Adventure Oxford; £Open REF: 816
- 3D Programmers, Adventure West of London; £Open REF: 815
- Games Programmers, RPG London; £Neg REF: 766
- PSX Progs, Var. games Manchester; £London wages in the North! REF: 806
- Two Senior Programmers, Sports East of London; £London levels REF: 804
- Games Programmers, 3D technology Surrey; to £35k REF: 651
- Senior PC Programmer West London; £35k + bonus REF: 786
- N64 Games Programmer - 6 mths Scotland; £High contract rates REF: 782
- Trainee Programmer, Historical adventure Oxon; £15k REF: 779
- Dreamcast Programmer, Shoot-em-up Surrey; £30k neg REF: 747

## Artists & Animators

- Two 3D Artists, Adventure Oxford; £Open REF: 817
- 3D Modeller, Simulation game Banbury; £26-30k REF: 812
- Lead Artist Surrey; £35-40k REF: 769
- Senior/Lead Artist, Various games London; £30-35k REF: 802
- 3D Artist, Futuristic game West London; £28-32k REF: 788
- New Titles Artist, Platform game Liverpool; £20-30k REF: 732
- Low Polygon Modelling, Var. games Harrogate; £Acc to exp REF: 675
- 3D Animators, TV Filmwork Scotland REF: 665

## Management & Other Positions

- Producer, Historical Adventure North London; £Neg REF: 792
- Assist. Producers x 2, Various games West of London; £Neg REF: 791
- Project Director, Cartoon game Surrey; £Neg REF: 783
- Dev Manager, All types of games Warks; £High exec package REF: 771

DATASCOPE

RECRUITMENT

Contact **Justin Hill** (programmers) or **Paul Wilkes** (artists and other)

## Datascope Recruitment

104 Great Portland Street, Tel: 0171-580 6018  
London W1N 5PE Fax: 0171-580 6068  
E-mail: info@datascope.co.uk

This is just a small selection. For hundreds more please visit:

[www.datascope.co.uk/datascope/](http://www.datascope.co.uk/datascope/)

## **ELECTRONIC GAMES PROFESSIONALS**

Leamington Spa £Excellent + benefits

How to lose friends  
and infiltrate

Just tell them you work at Codemasters. Describe the atmosphere here that's relaxed and electric, informal and hard working all at the same time. Explain the games you've been working on today. ("Playing", they'll scoff.) Then tell them about the excellent salary, the outstanding prospects, and the way the company's doubling in size every year.

We're looking for people who want to put their closest friendships to the test.

### **Games Development Manager**

A proven games professional, you'll bring new games to market on time and on budget through the adept management of our internal production teams. We'll expect you to juggle a diverse range of projects whilst keeping a keen eye on the budget, so you'll need to demonstrate a management approach that's both firm and flexible.

### **QA Manager**

Planning, co-ordinating and leading all activities in the QA department, you'll ensure that all games are tested on schedule and to our demanding standards. You will have at least 3 years' management experience (ideally in a QA environment or as a successful producer), we're looking for strong commercial nous, flexibility and outstanding communication skills. Foreign languages and specialist technical knowledge of games production and design, although not essential, would prove advantageous.

### **Programmer**

Designing and implementing code modules alongside other members of our high-calibre project according to agreed schedules and to the highest standard, you'll be industry experienced or a graduate in a relevant discipline, with excellent C programming skills, a creative approach, the ability to work in a team and high levels of self-motivation. Experience of C++, DirectX and PlayStation programming would all be beneficial.

### **Artist**

We're looking for creative flair, self-motivation and a recognised qualification in an art related discipline, alongside a good knowledge of 2D computer packages, 3D studio Max/Softimage, low polygon modelling and texturing skills using Photoshop.

When you join us, you'll need a real passion for video games and the desire to play an important role in a rapidly growing, hugely successful company.

In return for your commitment, you'll enjoy an excellent remuneration and benefits package and receive the ongoing training required to fulfill your career potential.

Send your CV with showreel, disk or other work examples (as appropriate), to: Stephen Harrison-Mirfield, Codemasters, PO Box 6, Leamington Spa, Warwickshire CV32 0SH. Alternatively, e-mail us: [recruitment@codemasters.com](mailto:recruitment@codemasters.com)

**Codemasters®** 

ds  
ence people

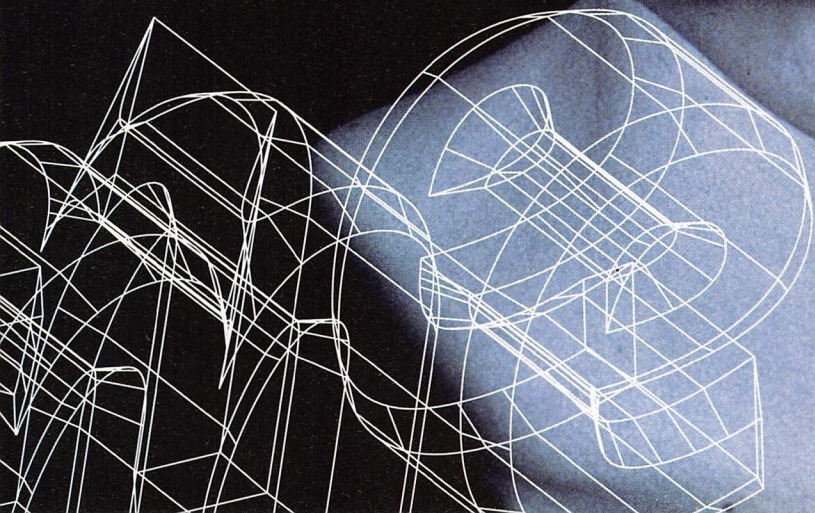

# INTERACTIVE STUDIOS

www.intstudios.co.uk

www.intstudios.co.uk



Hints, Tips, Help and Advice on getting into the Games Industry

## Shall we play a game?

INTERACTIVE STUDIOS IS RAPIDLY ESTABLISHING ITSELF AS A LEADING DEVELOPER OF ORIGINAL, CUTTING EDGE 3D GAMES FOR NINTENDO 64, PLAYSTATION, DREAMCAST & WINDOWS 95/98.

WE ARE CURRENTLY SEEKING MORE PEOPLE TO ADD TO OUR IN-HOUSE DEVELOPMENT TEAMS.

C/C++ PROGRAMMERS  
(WINDOWS/DIRECT X/PSX/N64/DREAMCAST)  
2D BITMAP ARTISTS (DPAIN/PHOTOSHOP)  
LOW POLYGON 3D ARTISTS/ANIMATORS (3DS MAX)

EXPERIENCE IS PREFERRED, BUT RAW TALENT IS RECOGNISED.

IF YOU HAVE A BURNING DESIRE TO HELP CREATE THE BEST GAMES IN THE WORLD THEN CONTACT US NOW FOR AN APPLICATION FORM.

TEL: 01926 311284

INTERACTIVE STUDIOS  
PO BOX 186  
LEAMINGTON SPA  
WARKS. CV32 4YL

DIRECT APPLICATIONS PREFERRED.  
DEMO'S WILL BE REQUIRED & ARE ALWAYS RETURNED.

INFANTRY SPEC  
PRIMARY WEAPON: BROWNING 32MM ASSAULT RIFLE  
ARMOUR: HEAVY  
VISIBILITY: HIGH

60 THUMPER TANKS

TANK SPEC:  
MAX SPEED: 60KM/H  
WEAPON SYSTEM: ELECTRO MAG BOLT PROJECTION TANK  
ARMOUR: 15MM COMPOUND CERAMIC  
RANGE: 200M  
POWER: 115 KW

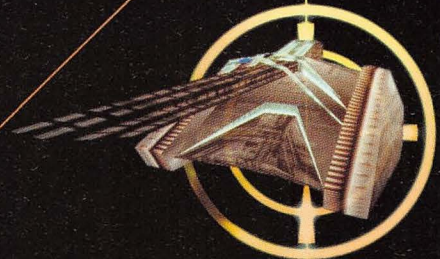

THUMPER SPEC:  
MAX SPEED: 50KM/H  
WEAPON SYSTEM: SINGLE HI-EX 200LB MORTAR  
ARMOUR: 20MM TITANIUM TURRET

120 MISSILE TANKS



# WAR GAMES

# RETRIBUTION



ALL TRADEMARKS ARE ACKNOWLEDGED AS PROPERTY OF THEIR RESPECTIVE OWNERS.  
FROGGER IS THE TRADEMARK OF KONAMI CO., LTD.



**Pelican Consultants** continue to offer the most professional and complete service to our clients and candidates. The most highly regarded developers and publishers trust us to find them the best talent from around the globe, and that same talent trusts us to help them find exactly what they are looking for in their career. How can we help you?

## PROGRAMMERS

**PC AND PLAYSTATION** **£NEG**  
World famous developer and publisher of chart topping titles seeks four programmers; two junior and two senior, to become the core of a new development team. A rare and exciting opportunity for the right candidate. Ref EDA001

**N64 TOOLS** **£25-30K**  
Third party developer with a long history of international titles is looking for a programmer with tools experience to join an N64 project. Must have strong C and C++ with good 3D theory and maths. Ref EDA002

**NEXT GENERATION CONSOLES** **£NEG**  
Developer and publisher of household name, triple A titles seek experienced programmers to work on Playstation and N64 titles with a view to Playstation 2. Must have at least one published title on either platform. Ref EDA003

**PC PROGRAMMERS** **£25K**  
Experience of the games industry is essential. This position will suit a programmer who has perhaps just completed one title and is now looking for a new challenge within a larger organisation. Ref EDA004

**PLAYSTATION PROGRAMMERS** **£25-30K**  
Two Programmers are required to mould the direction of Playstation development within this highly successful company. You will have at least one double A title to your credit and will be able to communicate your ideas effectively. Ref EDA005

**PLAYSTATION PROGRAMMERS** **£30K PLUS**  
This highly renowned developer has had triple A successes on all major platforms. Adding to their award winning team you will need to have worked on at least one Playstation title and will be eager to move up to Playstation 2. Ref EDA006

**DIRECT 3D PROGRAMMERS** **£25-30K**  
This company moved into games one year ago after a long standing history in the development of special effects for film and television. Now working towards their first major title they are looking for someone who can pull the very best out of Direct X and Direct 3D. Ref EDA007

**N64 PROGRAMMERS** **£NEG + ROYALTIES**  
Part of a major development group, this team require an N64 programmer to work on an Olympic Sports title. You will need at least 12 months experience of programming for the N64. Ref EDA008

**PC/DREAMCAST PROGRAMMER** **£LARGE**  
Required to join an experienced team working on a groundbreaking 3D strategy game. Must have two years' industry experience with completed projects. Console experience, C++, MSDEV 5 all an advantage. Ref EDA009

**PHYSICS PROGRAMMER** **£25K**  
Required to work on a racing title, you will have worked on physics engines in a games environment. Whilst games experience is an advantage, it is not essential and graduates may be considered. Ref EDA010

**GRADUATE PC PROGRAMMER** **£20K**  
Scotland based developer is looking for a junior programmer to join their already successful team. Working out of brand new offices, you will gain valuable experience in games development. A relevant degree is essential. Ref EDA011

**PC PROGRAMMER** **£20-25K**  
Must have worked on the graphics engine of a successful PC title. Whilst utilising Direct 3D is certainly an advantage, strong C skills and a clear approach to coding will be of interest. Ref EDA012

## ARTISTS

**3D ANIMATORS** **£UP TO 28K**  
Games developer with titles dating back to the 8 bit era are looking for experienced animators to join their thriving team. You will have worked on at least one triple A title and be able to demonstrate good 'all round' artistic skills. Ref EDA101

**CHARACTER ANIMATORS** **£NEG**  
Experienced in the creation and animation of 3D characters and textures, you will have used Character Studio and 3DS Max within the games industry. An ability to work on paper is also important. Ref EDA102

**FRONT END ARTIST** **£25K**  
Creating graphical user interfaces with a look and feel similar to TV broadcast, you will need experience of recognised 2D and 3D packages, preferably from within the games industry. Ref EDA103

**3D MODELLERS AND ARTISTS** **£25K**  
New development company based in the North of England are looking to add five more artists to their development team. Whilst games experience is not essential, you must be able to demonstrate an understanding of the techniques used. A demo will be required. Ref EDA104

**SOFTIMAGE ANIMATORS** **£NEG**  
Utilising this highly respected 3D package, this developer is looking for the best talent that the animation world has to offer. Experience in gaming is preferred but those working in either film or television will be considered. Ref EDA105

**CONSOLE ARTISTS** **£UP TO 30K**  
Experienced Artists required to join this world famous developer and publisher. A thorough understanding of the limits of consoles in the creation of 3D graphics is essential, hence games experience is preferred. Ref EDA106

**MODELLERS** **£25K**  
Scottish developer seeks Artists with skills in 3D Studio Max for the creation of environments and 3D worlds. 3DS Max used in conjunction with Photoshop for textures is essential. Ref EDA107

**ANIMATORS** **£NEG**  
3D Character Animators required to join developer working on PC, Playstation, N64, Dreamcast and eventually Playstation 2. Experience in the creation and animation of characters in games is essential. Ref EDA108

**MOTION CAPTURE ARTISTS** **£NEG**  
Dedicated motion capture studio working with games developers, film and TV production companies seek 3D Artists with at least 2 years' commercial experience using Alias and/or Maya. This company is known for setting the highest standards. Ref EDA109

**3D ARTISTS** **£20-30K**  
Scottish developer seeks character animators with skills in 3D Studio Max and Photoshop. Industry experience is not essential but a demo reel will be required. Ref EDA110

**MODELLERS** **£20-25K**  
Highly regarded games developer working on a well known games character seek modellers to create cartoon style environments. Games industry or computer generated cartoon experience is essential. Ref EDA111

**LEAD LIGHTWAVE ARTIST** **£UP TO 30K**  
Leading a team of highly accomplished artists, you will be able to bring the broadcast quality graphics of Lightwave to the gaming industry. Games industry experience is essential. Ref EDA112

## SPECIALISTS

**GENETIC ALGORITHM PROGRAMMER** **£35K**  
Games developer working on a title to bring together the best in AI with the best in real time 3D graphics. Of utmost importance are strong C++ skills and a working knowledge of the very latest developments in C++. Ref EDA201

**AUDIO PROGRAMMER** **£30K**  
This company are not only a successful games developer but have also recently signed to develop tools for the Playstation 2. You will be experienced in coding audio and MIDI data, preferably from within a games environment. This is not a position for composers or Audio Engineers. Ref EDA202

**LEAD ENGINEER** **£50K**  
Major toy developer has launched a new range of children's robots. We require an engineer with a strong background in either children's toys or robotics to develop software for this new range. Travel to Europe may form a regular part of this role. Ref EDA203

## PRODUCERS/DESIGNERS

**PRODUCER** **£30K**  
Developer of on line games has now moved into PC and console development with some lucrative publishing deals already signed. We are looking for a Producer who can lead two teams and oversee the addition of a further three in the next 6-8 months. Ref EDA301

**PROJECT ARCHITECT** **£25-30K**  
This position would suit an accomplished Programmer who was looking to move into the role of Producer. The company develop across all recognised platforms and you will need to be able to combine managerial skill with technical ability. Ref EDA302

**PROJECT MANAGER** **£30K PLUS**  
With a good history of developing triple A titles across all major platforms, this company need a Project Manager who is capable of leading a team in maintaining their track record. Experience in a similar role will be essential. Ref EDA303

**LEVEL DESIGNER** **£16K**  
Experience of level design is required by this well known developer currently working on a real time strategy title which is forecast to be a major success. You must have designed levels for a successful developer in the past. Ref EDA304

**LEVEL DESIGNER** **£NEG**  
Ideally with published product or experience in level design. Good knowledge of general game design will be an advantage. Demos will be required. Ref EDA305

**ASSISTANT PRODUCER** **£NEG + ROYALTIES**  
To work on Olympic Sports title. Project management software experience an advantage. Would suit individual with industry experience, not necessarily at Assistant Producer level. Ability in design or good understanding of programming and art. Ref EDA306

**PRODUCER** **£25-29K**  
Experienced Producer required to lead team developing cartoon style 3D platform game featuring world famous, licensed character. You will have worked on a similar style game and be looking for a new and exciting challenge. Ref EDA307

**PRODUCER** **£NEG**  
Successful developer and publisher who have shown a consistent profit for the past decade are looking for an experienced producer who can show an adaptive and flexible approach to work. Ref EDA308

## MANAGEMENT

**HEAD OF STUDIO** **LONDON**  
One of, if not THE most successful developer of console entertainment are looking for an experienced individual to head up their London studio. You will be able to show at least five years' management experience and be looking for a new challenge. Ref EDA401

**HEAD OF STUDIO** **LIVERPOOL**  
Games developer with studios worldwide are looking for someone to oversee software development in their main offices. This position will suit someone who feels ready to take on the most challenging role of their career. Ref EDA402

**TECHNICAL DIRECTOR** **SOUTH**  
Developer of triple A titles across all major platforms is looking for a technical director to oversee a number of teams. Whilst knowledge of the very latest programming techniques is essential, this position is much more about managing than it is about programming. Ref EDA403

**DEVELOPMENT DIRECTOR** **£NEG**  
Directing the development effort of an elite team, you will have demonstrated a consistent ability in the scheduling and timely delivery of top 10 titles. Ref EDA404

**QA MANAGER** **£NEG**  
You will have experience of QA, customer liaison and dealing with Sony submissions as a third party developer. This would suit an experienced producer looking for new responsibilities within the games industry. Ref EDA405

## INTERNATIONAL

**FRANCE**  
Highly successful games company are forming a second studio to continue their success. Programmers and Artists with industry experience required, as will be Producers to report to the Development Manager. Ref IN101

**CALIFORNIA**  
Developer and publisher with a licensed character are looking to add to their team. Programmers and Character animators with at least three titles to their credit required. Ref IN103

**TEXAS**  
World renowned developer and publisher are expanding their organisation and need industry experienced people to form their newest team. Ref IN105

**DUBLIN**  
Playstation Programmer required. Must have industry experience and a desire to contribute strongly to the design elements of triple A titles. Ref IN109

**SEATTLE**  
Developer of software in entertainment, tools and reference, we are looking for programmers who are at the peak of their profession. Ref IN110

**AMSTERDAM**  
Developing technology that will change the way we use the internet, we are looking for programmers and artists to develop on line content; the likes of which have not been seen before. Skills in traditional web development tools or art packages will be required. Ref IN111

All applications are treated with the utmost discretion.

For more information and an initial discussion, please contact:  
**PELICAN CONSULTANTS INTERNATIONAL LTD.** 7 Jardine House,  
The Harrovia Business Village, Bessborough Road, Harrow, Middx. HA1 3EX  
Tel (+44) 181 423 3400 Fax: (+44) 181 423 1117  
Email: [online@pelican-consultants.co.uk](mailto:online@pelican-consultants.co.uk) • World Wide Web: <http://www.pelican-consultants.com>



**Programmers, Artists, Designers, Producers OH MY**  
**We've Got deals that will make your head Spin**



**3D engine & Game Programmers**

12 months game programming or 1 game credit or better. Strong Knowledge of C,C++, DirectX/3d, 3dfx chipset. We are also seeking 3d engine coders. Salaries from 18K to 50K + profit shares etc.

**AI/Tools Programmers**

12 months game AI programming or 1 game credit or better. Strong Knowledge of C,C++. Salaries from 18K to 50K + profit shares etc.

**Playstation & Nintendo 64 Programmers**

12 months minimum coding on these consoles or 1 game credit or better. Yaroze Programmers welcome. Name your Price (ENEG)

**Dreamcast Programmers**

Only the best of the best wanted for this Babe. (£Neg + Profit Shares)

**3ds/Max,LW,Soft/Alias 3D Artist**

Skills all-round in Low & High Polygon modelling, animating, character design & environments.15K to 35K+ (graduates Please call first)

**Designer/Level Designers & Producers**

Game Industry experienced only (ENeg)

**Game Teams Wanted**

If you are a team of Programmers and Artists wanting to develop for PC/PSX/N64, call us first. We are currently setting up teams. Game teams must have excellent track records & original game concepts.

**GameBoy Coders & Artists**

**Graduate 3d programmers** 12K to 18K+  
 We are seeking BSC/MSC grads with strong 3d graphics programmers skills. Candidate must submit 3d graphics programmed demo, this is compulsory.

**Seeking Private Investors for PC/PSX/N64 development**

We are seeking private investors who can finance professional game teams developing 3D games for PC/PSX/N64 & Dreamcast. If you are interested & want to find out more CALL US. All teams have tracks records and 3d Technology.

**USE KRS EXCLUSIVELY**

Krystal is the only company in the entire UK who (apart from helping a huge number of game people find cool jobs) have a team of consultants who work full-time in game design and development, allowing us to communicate on a game-development level.

**WE SERVE GAME LOVERS (WE ARE NOT PENCIL NECKS LIKE THE OTHERS)**  
KRS is a sister company of Super3dPower Studios

Recruiting at: London, Guildford, Essex, Middlesex, Warwick, Bristol, Somerset, Banbury, Birmingham, Coventry, Derby, Nottingham, Staffs, Cheshire, Manchester, Leeds, York, Stockton on Tees, Newcastle, Liverpool, Knutsford, Sheffield, Dundee, Glasgow, Runcorn, and many other UK Locations.

Submit CV (email or floppy Preferred, Not hard Copy) to Kassey Chand Jr

NOTE, CV's IN WORD OR TEXT FORMAT ONLY

**Krystal (KRS)**  
 email: [krystal@panther.netmania.co.uk](mailto:krystal@panther.netmania.co.uk)  
 Tel: 0181 599 8691 - Fax: 0181 262 8696

11 Goodmayes Ave, Goodmayes Ilford Essex IG3 8TN London UK.



Demo work (email preferred or CD/Zip/Disk/Floppy or VHS)

Specialist consultants to the Games Industry for experienced and Senior staff



**YOUR FUTURE STARTS HERE**  
 Small ad,  
 HUGE opportunity

Have you the skills and passion to contribute to great next generation product?  
 Immediate openings in all parts of UK and many abroad.

**PROGRAMMERS £14K - £45K 3D, PC, Engine, Dreamcast, N64, PSX, AI, Z80, Mac, new graduates.**

**ARTISTS £12K - £35K 3D, 2D texture, modellers, animators, human figure, traditional low polygon, FMV**

plus QA, **PROJECT MANAGEMENT, LEVEL/GAMES DESIGN, PC SUPPORT, LOCALISATION AND OCCASIONALLY TEAM OPTIONS.**



Register NOW! Submit CV's to:

Dave Hill, Interactive Personnel, 7-11 Kensington High Street, London W8 5NP

Tel: (0171) 411 3184 Fax: (0171) 937 2579 Email: [INTERACTPERSONEL@HOTMAIL.COM](mailto:INTERACTPERSONEL@HOTMAIL.COM)

Our service is free and strictly confidential.



## Animated People Recruitment

Games →

Film →

TV →

VR →

**3D ANIMATORS** ↓

Maya - 3DS / Max - Softimage

**3D PROGRAMMERS** ↓

C++ - Assembler

0181 446 7631

<http://business.virgin.net/animated.people>

**game physics**

opportunities for Programmers

Requirements: good C/C++, Highly numerate (expertise in AI, 3D or physics an advantage).

Salary: negotiable, plus share options

Contact: send a CV to Ellen Griffiths at the address below, alternatively email [ellen.griffiths@mathengine.com](mailto:ellen.griffiths@mathengine.com)



MathEngine plc

Oxford Centre for Innovation

Mill Street Oxford OX2 0JX

T +44 (0)1865 792445 F +44 (0)1865 263901

[info@mathengine.com](mailto:info@mathengine.com)

[www.mathengine.com](http://www.mathengine.com)

## Programmers Required PC / Console:

Experienced Windows 95 / Direct 3D programmers (C/C++) with the ability to produce exceptional code.

We want to hear from any console programmers for a number of new projects.

## Artists Required

3D modellers and animators:  
3DS Max / Photoshop required.

If you are not listed above but have a burning desire to be part of an independent games developer then we want to hear from you.

Please send your C.V. and examples of work to:

# MICROTIME

Dawn Pinkney  
Microtime Developments Ltd  
Microtime House  
Bonny Street  
Camden Town  
London  
NW1 9PG

Tel: 0171 267 4422 Fax: 0171 267 4399  
E-mail: [personnel@microtime.co.uk](mailto:personnel@microtime.co.uk)

**OPM** has enjoyed tremendous success in 1998, and we are ready to help you find your ideal job in 1999. We have a wealth of opportunities nationwide and are currently looking for staff on behalf of a variety of clients, from large international publishers to small independent developers.

Current vacancies include Creative and Technical posts from Head of Development through all levels of Producing, Project Management, Programming, Art, Design, QA and Test.

If you are ready to further your career working on projects for Dreamcast, PSX, PC, N64, and Gameboy in every established genre, (and a few new ones), and would like to be represented by a truly professional recruiter, we need to talk.

Many of our vacancies are exclusive, so if you are not registered you cannot be considered.

For details of our vacancies, and on-line registration:  
[www.opmresponse.co.uk](http://www.opmresponse.co.uk)

<b>Head of Development</b> for location & package please call Kim Adcock.....ref 188		
<b>Head of Business Development</b>		
Licensing Manager	London.....to £60k.....ref 246	
Web Publishing Project Manager	Midlands.....to £45k.....ref 159	
Technical Director	South West.....to £30k.....ref 246	
Technical Director	London.....to £40k.....ref 190	
Development Manager	South West.....to £30k.....ref 184	
Senior Technical Producer	London.....to £40k.....ref 238	
Technical Manager	North.....to £30k.....ref 216	
Senior Producer	East.....to £40k.....ref 255	
Internal Producer	London.....to £35k.....ref 230	
Internal Producer	West.....to £35k.....ref 244	
External Producer	South West.....to £35k.....ref 211	
External Producer	London.....to £30k.....ref 151	
Internal Producer	London.....to £30k.....ref 227	
Internal Producer	South West.....to £30k.....ref 129	
Internal Producer	Scotland.....to £30k.....ref 229	
Internal Producer	South.....to £35k.....ref 131	
Internal Producer	West.....to £40k.....ref 234	
Internal Producer	London.....to £45k.....ref 217	
Internal Producer	London.....to £40k.....ref 235	
Game Designers x 2	London.....to £30k.....ref 218	
Game Designer	London.....to £35k.....ref 224	
Game Designer	Midlands.....to £25k.....ref 175	
Senior Designer	East.....to £30k.....ref 256	
Freelance Games Writer	West.....negotiable.....ref 259	
Lead QA	Midlands.....to £18k.....ref 134	
Tester	London.....to £14k.....ref 253	
Audio Programmers x 2	South West.....to £35k.....ref 205	

Senior / Lead / Programmers, C, C++, AI,  
3D, Console,  
PC, Network, Games,  
Multimedia & Film

Nationwide recruitment  
£OPEN

ref: 57 68 101 117 127 130 136 149 157 163 165  
181 185 187 193 200 202 206 207 212 215 220 222  
231 236 239 240 245 248 249 252 257 258 & 260

Lead / Artists, Animators, 3Ds,  
SGi, Games, Multimedia & Film,  
3D, 2D, PC, Console

Nationwide recruitment  
£OPEN

ref: 69 92 114 115 116 128 137 150 158  
164 166 171 172 180 186 189 194 201 203 213  
214 224 232 237 250 251 253 254 & 261

Please send your CV including your salary and location requirements, and demo material, either via our interactive web site, by fax or post, to:

Kim Adcock  
OPM Response Ltd  
17c West Street  
Colchester  
CO2 7BG

Tel: 01206 544044  
Fax: 01206 547198

email: [recruit@opmresponse.co.uk](mailto:recruit@opmresponse.co.uk)  
[www.opmresponse.co.uk](http://www.opmresponse.co.uk)

## Engine Programmers

## Game Coders

## In-Game Artists

## Animators

## FMV Specialists

## Designers

## Producers

## Sound Specialists

**£20,000-£60,000**

## Your career's about to enter a whole new level

Elan's experience in placing gamers with top-flight developers will be the ideal springboard for your career.

Whether you're a Senior Developer, or just committed to becoming one, we'll find the perfect next move for you. Our clients number top drawer developers with worldwide openings for Programmers, Artists, Producers and Designers, all at salaries to suit your experience.

So whether you're looking to work overseas, or just searching for a little old-fashioned creative freedom, talk to Elan.

UK EUROPE USA ASIA PAC

Contact Barrie Parker, Games Specialist, Elan, Games Division, Milton House, 66-68 Chertsey Street, Guildford, Surrey GU1 4HL.  
Tel: 01483 883323 Fax: 01483 883300 E-mail: [bdp@elan.co.uk](mailto:bdp@elan.co.uk)

Visit our website <http://www.elan.co.uk>

**Elan** 

1999. In a whole range of ways, it stands to be the biggest year of Rare's career so far. From our brand new HQ in the heart of the country, a development heaven custom-built over the last two years, we're hoping to deliver a steady stream of games that prove well up to the expectations raised by such recent Rare alumni as *GoldenEye 007*, *Diddy Kong Racing* and *Banjo-Kazooie*.

And with the keen buzz of anticipation surrounding our future titles, we've certainly got our work cut out as we shimmy towards the turn of the millennium and the utter collapse of civilisation as we know it, apparently. There'll be trigger-happy 3D space adventure in *Jet Force Gemini*, epic first-person future shocks in *Perfect Dark*, sprawling sequel action in *Banjo-Tooie*, long-awaited squirrel escapades in *Twelve Tales: Conker 64* and its hand-held sibling *Conker's Pocket Tales*, and of course Kremling-bashing antics aplenty in the 64-bit incarnation of videogaming's prime primate, *Donkey Kong*. All this and much more is on its way, and Rare has huge long-term prospects to offer (putting aside the end of the world for a moment) if you're skilful and dedicated enough to join us in raising the bar even higher...

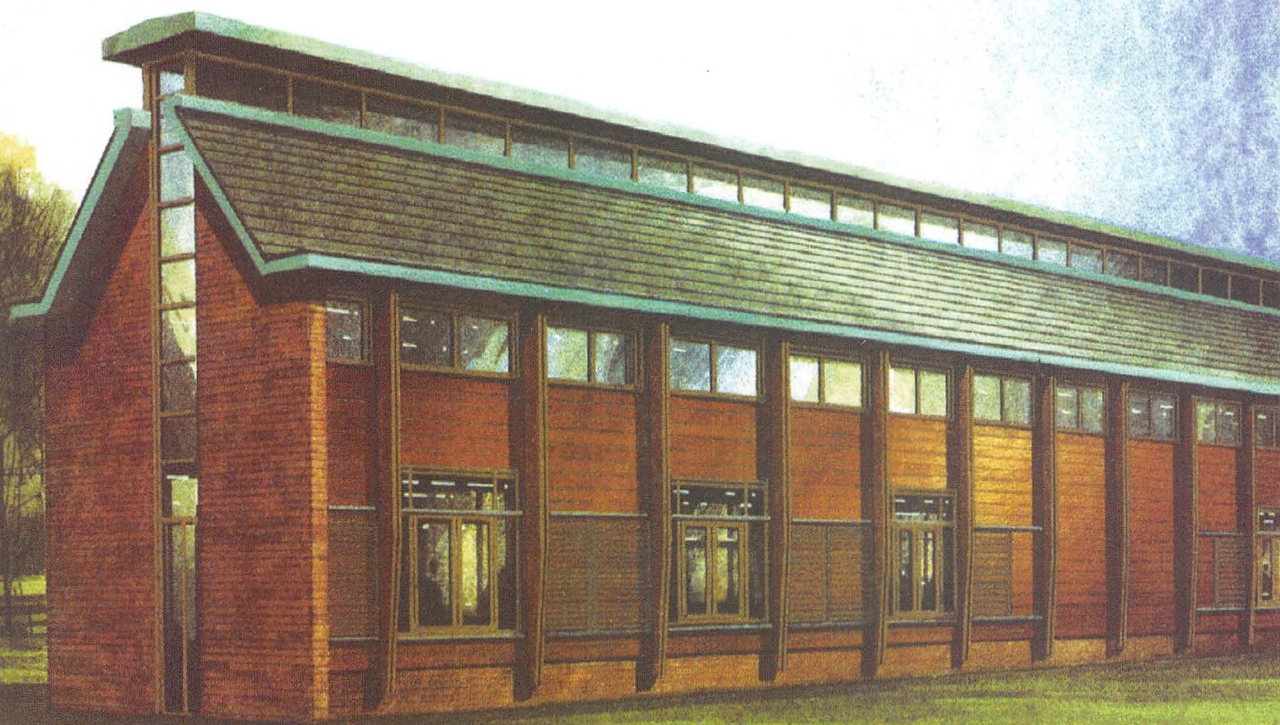

Please submit CVs and work examples to:

Personnel Dept., Rare Ltd., Manor Park  
Twycross, Warwickshire CV9 3QN.

**SOFTWARE ENGINEERS:** To code cutting-edge software using high-end Silicon Graphics workstations. Applicants must be fluent in C or Assembler. Enthusiasm for games a definite advantage.

**3D ARTISTS:** With good all-round abilities in modelling, animating and designing characters and their environments. Successful applicants will use Alias and GameGen software on Silicon Graphics hardware. Previous experience with 3D packages useful but not essential.

**MUSICIANS:** Needing the ability to write excellent tunes in a variety of styles, coupled with a good technical knowledge of audio equipment and MIDI. Familiarity with Cubase and interest in games an advantage.

**SYSTEM TOOLS ENGINEERS:** To create in-house development tools and editors for use in new and ongoing projects. Knowledge of C and C++ vital.

**GAME BOY COLOR ENGINEERS:** For development of new titles as part of our dedicated Game Boy team. Must be fluent in Assembler. Previous Game Boy experience a benefit but not essential.



IF WE EXPECT YOU TO GIVE US EVERYTHING  
IT'S ONLY FAIR WE DO THE SAME:-

A UNIQUE WORKING ENVIRONMENT  
THAT EMPHASISES FREEDOM AND CREATIVITY  
ABOVE ALL ELSE

EXPERIENCED, FRIENDLY AND PROFESSIONAL  
CO-WORKERS

NUMEROUS, VARIED, HIGH-PROFILE PROJECTS

ATTRACTIVE BONUS AND ROYALTY PACKAGES

AND MOST IMPORTANTLY

OUTSTANDING OPPORTUNITY FOR  
PERSONAL GROWTH

ARE YOU UP FOR IT?

PROGRAMMERS

ARTISTS

PRODUCERS

NEEDED FOR:

PSX

N64

DREAMCAST

GAMEBOY COLOR

PC



CLIMAX GROUP  
FAREHAM HEIGHTS  
STANDARD WAY

FAREHAM  
PO16 8XT

PERSONNEL@CLIMAX.CO.UK

WWW.CLIMAX.CO.UK

# STAY AHEAD OF THE GAME INTERACT WITH AN AARDVARK!

## Programmers

**Home based contract PlayStation Programmers**  
.....3 options, 2 in the South, 1 in the North

**Programmer** Progressive organisation with highly innovative product require high quality experienced programmer with C++, AI, Win32 and 3D. Neural Networks and Artificial Life systems advantageous. Creative company with leading edge technology..... **£25-35k (London)**

**Localisation Programmer** Role entails the cultural adaptation of games software for overseas markets. C++, Windows essential. Assembler advantageous. Varied role. USA owned company - with occasional visits to the States ....  
..... **£18-22k + "Large Company Benefits" (South)**

**C++/AI Programmer** PC strategy product. Sequel to bestseller. Multiplayer/network coding beneficial. Experienced directors, great working atmosphere. Newly qualified graduates considered ..... **£16-30k (South West)**

**PlayStation Programmers** Established industry player. Varied and interesting work in progress includes comic licences, a major project for a Danish toy company, film and motion capture, and a new racing game.....**£High (Midlands)**

**PC/PlayStation Programmers (x5)** Established secure developer. Diverse genres. Drive and construct, strategy, sports management, character action. Yaroze experience suitable for PSX roles. Prestigious new offices overlooking greenery. Well organised yet relaxed environment .....  
..... **£18-28k + benefits (London)**

**Programmers (x2)** PC, PSX, N64 & Dreamcast studio, developing 3<sup>rd</sup> person perspective product from Hollywood licence. C, C++ 3D graphics, game physics advantageous. 1999 graduates considered ..... **£15-25k (Scotland)**

**Graphics Programmers (x5)** Competent experienced coders sought for new project with well established and respected international organisation. Entails developing character animation systems and graphics engine. Knowledge of IK and surface subdivision techniques beneficial.....  
..... **£18-28k + bonuses (North)**

**3D Engine Programmer** Successful London developer with new contract with French publisher needs an additional experienced and enthusiastic programmer for core technology division working in close conjunction with two project teams. C skills and team playing attitude mandatory. Leading edge spine technology. Character based product with a difference .....  
..... **£25-38k + royalties (London)**

**AI Programmer (URGENT)** Highly progressive and original organisation with flair for creativity seek focused individual for integrating AI with scripting systems and behavioural aspects. Genetic code and pathfinding routines advantageous .....  
..... **to £30k + royalties**

**3D Programmer** Well established multi-million dollar Japanese publisher seeks experienced programmers with Maths, Physics, DirectX for racing product. Prestigious official licence. New studio. Second project. New Team needed .....  
..... **£25-38k + bonus + royalties (North West)**

**Gameboy Programmers**  
.....**(Very many vacancies nationally! Also home-based options)**

**PlayStation Programmers** Still high level of demand. Several clients quoting "pay whatever it takes!" .....  
..... **£Highly competitive (Countless opportunities nationwide)**

**Dreamcast Programmers** Typical requirements are for 3D and open GL skills.....  
..... **£Excellent (All locations)**

**If you want to know where the best opportunities are right now, get interactive with us.**

**Formed in 1989, Aardvark Swift is the longest established games agency in the UK with many well known companies now using our services exclusively. The bottom line is... if we don't have your details on file, you simply can't be considered for these opportunities - many of which are only advertised via ourselves. Don't miss out!**

## Artists

**SoftImage Artists** Fancy being in the movies? Prestigious studio currently seek creative skills for special effects and compositing for the latest in a series of box office blockbusters .....  
..... **£20-30k + profit share (London)**

**Graphic Artist** Action sports product. 3D Studio Max modelling and some animation work. Rotoscoped product. Small creative division of multinational giant.....  
..... **c£25k + bonuses (London)**

**Video/TV, Post Production** Established studio seek 3D Studio Softimage, Wavefront skills. Urgent requirements. Immediate start. Company snowed under with graphics work and orders .....  
..... **£Neg (North West)**

**3D Graphic Artists** Highly qualified CG film production work. Exceptional candidates wanted for exceptional opportunities. Ideal profiles include experience with the following. Nurbs and Polygonal modelling, effects object and camera animation, shading and real world lighting techniques and rendering optimisation. Alias/Wavefront Maya preferred.....  
..... **£25-30k (South East)**

**Graphic Artists (x2)** Good all rounders needed by development house with a 17 year history. Sports and construction products being developed for PC and PlayStation.....  
..... **c£24k (Including monthly bonus) + royalty deal (Yorkshire)**

**3DS Max Artists (x3)** London developer utilising cutting edge engine technology requires min 2 years experience and character creation for R/T action adventure product. Motivated team in non corporate environment .....  
..... **£High + bonuses + royalty (South East)**

**2D Artist** Young company requires proficient Photoshop skills for sim product. Prospects to design role... **£13-18k (Oxon)**

**Graphic Artists (x3)** Major influential player currently seeks experienced creative people for new project. (3DS Max, Textures, NURBS, Spline, Mo-Cap skills all needed) ....  
..... **£18-25k + bonuses (North)**

**Senior Animator** Young company with very impressive work in progress. Traditional and computer skills needed. Well funded.....  
..... **£25-35k + bonuses (Surrey)**

**Graphic Artist/Animators** New company with full financial backing headed by well respected individual and a number of other high profile 'names'. Real time and high poly work. Game and educational software with a new technology/leading edge graphics emphasis. Very exciting opportunity to join select talented creative team .....  
..... **to £32k (South East)**

## Management

**Senior Producer** Multiple team project management role. Company developing sports and adventure product.....  
..... **£30-35k + possible share options**

**Senior Quality Assurance** Head up QA and customer services departments encompassing overall responsibility for approximately 35 people (to be extended to 50). Well educated, experienced manager sought by leading industry player with a plethora of number ones.....  
..... **£30-40k + benefits**

**Producers (x2)** Newly created internal roles with prestigious international organisation. Racing and sports interest beneficial. Superb opportunities at one of the industry's best .....  
..... **to £40k (London)**

**External Producer** Manage two high-profile AAA developers with assistance of junior producer. Well known and respected publisher .....  
..... **£28-38k + bonuses + car (South East)**

**Sports Producer** Two similar positions at two separate companies. Both high profile, successful organisations. Keen interest in sport essential .....  
..... **c£45k (North)**

**Technical Director** Provide career guidance and maintain quality, consistency and organisational integrity of programming department. Good leadership and programming skills mandatory. Well established, high profile company .....  
..... **£Neg + bonuses etc (London)**

## Others

**Games Designer** Successful independent developer require proven design skills in flight sim arena. Award winning previous product portfolio. Well run and managed company .....  
..... **£23-28k + bonuses (South)**

**Games Designer** Venture capital funded fully independent organisation require experienced designer to assist in completing 3D shoot em up type product. Prestigious offices .....  
..... **c£25k + studio profit share (South East)**

**Senior Designer** UK studio of successful USA developer. Highly creative organisation. Key appointment.....  
..... **£25-32k (North)**

**Level Designers (x3)** Good general game design. knowledge and demos required.....  
..... **£16-20k + bonus + royalties (S. Midlands)**

**Audio Engineer** Design original sounds and effects in conjunction with in house musician. Creative individual required with knowledge of synthesis, FM and DSP beneficial. Multi-national, well financed group .....  
..... **£20-28k (Surrey)**

**Designers/Lead Designers** Racing genre (and confidential project). High profile company with excellent benefits package. Gamegen or multigen creator advantageous.....  
..... **£16-28k + bonuses**

## Abroad

**3D Programmers** Latest technology .....  
..... **£Excellent (Sydney & Canberra)**

**Programmers/Artists (USA)** Well respected West Coast developer always in the market for 'good Brits' to join team in sunny California. Company work for major publishers, are British owned and are just 7 miles from the beach .....  
..... **\$65-80k + royalties, medical and legal fees**

**Register by sending a CV (& examples where applicable) to:**

**Aardvark Swift Consulting Ltd, Silicon House, Farfield Park, Wath upon Dearne, Rotherham, South Yorkshire S63 7DB**

**Tel: (01709) 876877 Fax: (01709) 760134 Email: SLD@ardswift.demon.co.uk**

**Many more vacancies at [www.ardswift.co.uk](http://www.ardswift.co.uk)**

**Please indicate locational preferences and salary guidelines.**

**All enquiries and applications will be treated in the strictest confidence.**



GET AHEAD WITH ZODIAC



We've placed people in top game jobs since the early 90's. In fact, we've probably helped more development staff find 'THE RIGHT JOB' than any other agency in the UK. Our client base ranges from small software development teams to world-leading leisure software publishers. We have vacancies in most geographical areas of the UK as well as overseas opportunities. Below is a small selection of current national requirements.

Lots more vacancies at: [www.zodiac1.demon.co.uk](http://www.zodiac1.demon.co.uk)

### Programmers

**PC/PSX Programmers** to £30k (Yorkshire)  
Industry experience essential. Sound C/C++ skills. Well established and respected developer.

**PSX Programmers (x2)** £Large + Royalties (Oxon)  
C/C++, 3D 1st/3rd person engine experience preferable.

**PC/PSX/Dreamcast Programmers** £High (Scotland)  
Arcade style flying game. Good games background and at least one published title required.

**PlayStation Programmer** £22-38k + Bonus (S/East)  
Urgently required by top class developer to work on the sequel to their hit racing game.

**Programmers** £Neg + Bonus (Warwickshire)  
Countless opportunities from this hugely successful developer. PC, PSX, Dreamcast, Nintendo 64. To work on the official Olympic games for the year 2000 or the 'Rollcage' series.

**Graduate Programmers** £Neg (Various sites)  
C/C++, 3D maths/physics background. Passion for games.

**Senior Programmers** £Neg (London)  
To work on exciting new football and action products on the PC, PSX, N64 and Dreamcast. At least one published title required.

**PC/PlayStation Programmer** to £25k (North West)  
C/C++/3D maths/physics. To work on racing games (fantasy and real life simulators). Great working atmosphere!

### Artists

**Animators (x3)** £Neg (London)  
3D Studio Max with experience of motion capture preferred. This company offers excellent career prospects.

**Artists** £High + Bonus (Warwickshire)  
3DS Max and Photoshop or similar texture package. To work on major sports title for the year 2000 or the Rollcage series.

**Lead 3D Artist** £High + Benefits (Scotland)  
To work for this major, well respected developer. Softimage skills and previous industry experience essential.

**2D & 3D Artists** to £25k (North West)  
To work on racing products (fantasy and real life simulators) for the PC and PSX platforms. Great working atmosphere!

**Animators (x3)** to £30k (South)  
Strong character design/animation skills required by this high profile company. Ideally some Alias experience but not essential.

**Animators (x2)** £Neg (Yorkshire)  
Proficient computer animator with good drawing ability. Lightwave or Softimage skills. Would suit recent graduate.

To apply, forward your CV (& work samples where relevant) to Marie Harris  
Zodiac Pursuit, Raines House, 9 Edgerton Court, Tadcaster, LS24 9NZ.  
Tel: 01937 835700 Fax: 01937 531986 Email: [marie@zodiac1.demon.co.uk](mailto:marie@zodiac1.demon.co.uk)



( e d g e m o v e s )

Contact  
Chris Hail

Future Publishing, 99 Baker Street,  
London, W1M 1FB

(email: [chris.hail@futurenet.co.uk](mailto:chris.hail@futurenet.co.uk))

t e l : 0 1 7 1 3 1 7 2 6 0 4

Rates Double-page spread £4,000 • Full page £2,000 • Half page £1,000 • Quarter page £500

## SUCCESS HAS ITS PROBLEMS!

Due to demand we are expanding and need highly motivated Top Quality Producers, Programmers and Artists to join our development team working on Blockbusting Leading Edge Games.

Data Design has a 15 year history of developing high-profile, quality games. Working on licenced and original products with companies such as Time Warner, Sony, Disney, MCA / Universal studios, Ocean, Infogrames, Eidos, BBC and Lego Media.

Our graphics division Artworld (UK) is working on some exciting new ventures. Jointly with Egmont/Fleetway we are developing the World's First Rendered Comic, as well as animation sequences, T.V. Adverts, Box Cover Artwork and we are about to start work on a fully rendered feature film.

If you possess excellent 'C' programming skills for PC or PSX, or movie quality 3D and animation skills, combined with an eye for detail, the enthusiasm, desire and determination to do whatever it takes to produce 'AAA' products then you want to speak to us NOW!

Contact: Eamonn P. Barr  
Data Design Interactive, 10/11 Birmingham Street, Halesowen  
West Midlands, B63 3HN, England.

Tel: (+44) 0121 503 3820

Email: [eamonn\\_barr@datadesign.demon.co.uk](mailto:eamonn_barr@datadesign.demon.co.uk)





# RUNE CRAFT

As part of our continued expansion we are looking to recruit additional talented Programmers, Artists, Animators and Game testers.

We offer great rates of pay, overtime and a good working environment. Suitable applicants will have industry experience, be a team player and should apply to:

**Keith Jackson**

**RuneCraft Limited,  
The Old Eightlands Well,  
Eightlands Road,  
Dewsbury  
West Yorkshire  
WF13 2PF**

**Tel: 01924 500817**

**Fax: 01924 500898**

**E-mail: [jobs@runecraft.co.uk](mailto:jobs@runecraft.co.uk)**

**·RUNE·CRAFT·**

The developers of Tank Racer, Team Apache, MIA and FST are looking for bright and enthusiastic developers to join one of our Surrey studios.

#### Programmers

Senior Software Engineers: 3 Years+ C/C++, DirectX  
1 or more published PC game(s) an advantage.

Programmers: 1 Year+ C/C++, DirectX  
Games experience ideal but not essential.

Associate Programmers: Strong C/C++.

All applicants should have a good academic record including a degree in Computer Science or a related subject.

#### Artists

Senior Artist: 3 Years+ low polygon 3D modelling & texturing  
3DS Max experience essential.

Graphic Artists: 1 Year+ low polygon 3D modelling & texturing  
3DS Max experience an advantage.

All applicants for artist positions should be able to show a portfolio of artwork (including low polygon modelling work).



# GLASS GHOST

Please send your CV and examples of work to:-

Aardvark Swift Consulting Limited  
Silicon House,  
Farfield House,  
Wath-upon-Deerne,  
Rotherham,  
South Yorkshire,  
S63 7DB

Tel: 01709 876877  
Fax: 01709 760134  
E-Mail: SLD@Ardsdswift.demon.co.uk

# SIMIS

## Computer ARTWORKS



Computer Artworks, creators of **ORGANIC ART** and the innovative action strategy game **EVOLVA** are recruiting **PROGRAMMERS** and **SENIOR PROGRAMMERS**. We offer high calibre, motivated individuals the opportunity to work on cutting-edge game development at our central London studio. We require experience in some or all of the following:

A-Life, AI  
Dynamics  
Networking  
Tools  
Optimisation.

Submit C.V. to Lucy Donaldson  
Tel: 0171 370 4070  
Fax: 0171 370 4077  
Email: [recruitment@artworks.co.uk](mailto:recruitment@artworks.co.uk)  
Website: [www.artworks.co.uk](http://www.artworks.co.uk)

# GAME CONVERSIONS

**ALL FORMATS**



**FREE NO OBLIGATION PROJECT ASSESSMENTS**



- **New developments**
- **NTSC-PAL/localisations**
- **Experienced talented teams**
- **Prototyping**
- **Graphical alterations**
- **Design**

Also available: rendering, animation, modelling & compositing services

*Extreme*



Tel: +44 (0)1952 208702  
 Fax: +44 (0)1952 208704  
 E-mail: extreme.fx@dial.pipex.com

Extreme Fx Limited is a member of the Visual Gold Group

07/02/02/01 REF 01

# ANIMATION

ANIMATION

**SPECIALIST SERVICES FOR THE ENTERTAINMENT INDUSTRY**

- **FMV SEQUENCES**  
- Full Motion Video - in-game animation sequences or a preview "mini movie" to your latest release
- **HIGH RESOLUTION ANIMATION**  
- Sophisticated and detailed graphics for animation sequences
- **MODELLING**  
- Creation and supply of high definition, fully textured meshes
- **SPECIAL EFFECTS**  
- Stunning visual effects created using the very latest technology
- **RENDERING**  
- Large on site facilities available
- **COMPOSITING**  
- Blue screen filming and mat line backgrounds
- **SCULPTURED MODELS**  
- Highly detailed representations of characters and objects



**3D Films**

Tel: +44 (0)1952 208701  
 Fax: +44 (0)1952 208704  
 E-mail: 3d.films@dial.pipex.com

3D Films Limited is a member of the Visual Gold Group

07/02/02/01 REF 01

**Steel Monkeys**



**CLASS 1  
 Programmers  
 Animators  
 Artists**

**WANTED**

e: recruitment@steelmonkeys.com  
 w: www.steelmonkeys.com

dreamcast\_pc\_psx\_cgb\_n64\_ai

Steel Monkeys [CLASS 1 Game product]

**Steel Monkeys Ltd.**

Grange House, Grange Place, Kilmarnock KA1 2AB



cool beans

Cool Beans is expanding its team of artists and animators for intensive CG film production.

#### WANTED

Maya modellers and animators  
Softimage modellers  
High-resolution texture artists  
Renderman Shader writers  
Traditional 2D animators and artists

Experience on high-end Silicon Graphics workstations useful but not essential.

Successful applicants will demonstrate excellent skills in their chosen field. Showreels / portfolios must be included with CV.

Applications to: Zoe Norton Cool Beans Productions Ltd  
Brook House 557 Ecclesall Road Sheffield S11 8PR  
Tel: 0114 2670704 Fax: 0114 2682123

E-mail: [recruitment@coolbeans.co.uk](mailto:recruitment@coolbeans.co.uk)

[www.coolbeans.co.uk](http://www.coolbeans.co.uk)

SILICON VALLEY / UK START UP LOOKING FOR

## GAMES DESIGNER

TO WORK ON A SERIES OF CONSOLE-BASED, GENRE-BREAKING, NEW TITLES.

PRIMARILY WE ARE LOOKING FOR AN INDIVIDUAL WITH A STRONG CONCEPTUAL APPROACH AND THE ABILITY TO WORK WITH ABSTRACT GAME IDEAS - POSSIBLY WITH PUZZLE GAME EXPERIENCE.

SOMEONE WITH THE DRIVE TO DEVELOP THE NEXT GENERATION OF CONSOLE TITLES, WHO IS BOTH SELF MOTIVATED AND WILLING TO INTEGRATE INTO AN EXISTING TEAM.

WE OFFER A COMPETITIVE SALARY. SEND A CV AND ANY EXAMPLES OF WORK TO: [IM-STUDIOS@JOWITT.U-NET.COM](mailto:IM-STUDIOS@JOWITT.U-NET.COM)  
TEL: JONATHAN, 01709 878153 IM-STUDIOS : 2 RAINBOROUGH MEWS : BRAMPTON BIERLOW : S.YORKS : S63 6BF

( e d g e m o v e s )

### Contact Chris Hall

(email: [chris.hall@futurenet.co.uk](mailto:chris.hall@futurenet.co.uk))

Future Publishing,  
99 Baker Street,  
London, W1M 1FB

### Rates

Double-page spread £4,000

Full page £2,000

Half page £1,000

Quarter page £500

t e l : 0 1 7 1 3 1 7 2 6 0 4

*Founded in 1991,  
Answers Ltd has  
developed an  
unrivalled reputation  
for a service built  
on trust and results  
based on quality of  
recruitment expertise  
and specialist  
industry knowledge.*

## ANSWERS

Please submit your CV with demo material on disk, video or paper detailing current salary and daytime contact number to:

#### UK OFFICE

Lis Welsh, Answers Ltd,  
The Old Rectory, Holdenby,  
Northampton, NN6 8DJ

Tel: (+44) 01604 771122 Fax: (+44) 01604 771172

Email: [recruit@answers.u-net.com](mailto:recruit@answers.u-net.com)  
<http://www.answers-recruitment.com>

#### FRENCH OFFICE

Anne-Marie Joassim, Answers France,  
34 Rue Laborde,  
75008 Paris

Tel: 00 33 1 42 94 28 23 Fax: 00 33 1 42 94 28 24

Email: [answers@easy.net.fr](mailto:answers@easy.net.fr)

## PSX 2 Recruitment

Our client, a leading developer and publisher of interactive computer games, is looking to fill the following positions through Answers

FOR THE OPPORTUNITIES NO-ONE ELSE HAS - A ONCE IN A LIFETIME CHANCE, REGISTER WITH ANSWERS THE UNDISPUTED MARKET LEADER, WORKING ONLY WITH MARKET LEADERS.

### DEVELOPMENT MANAGER

up to £65k + car + benefits

Managing predominantly PlayStation 2 projects using the latest technology and possibly being involved with the industry's most challenging products of its time.

You must be an outstanding individual with a proven track record in managing a staff of up to 60 people through dedicated, experienced team leaders. Your knowledge of the industry past and present, but in particular future, must be second to none, as is the ability to lead from the front and gain respect from your staff. Able to present concepts at board level and support your case in a highly challenging environment.

- Industry knowledge
- Management skills
- PSX 2 opportunity

Ref 2039

### PSX 2 PROGRAMMER

c£40k + benefits

Centrally located in purpose-built offices, working on the very latest technology.

A 'must have on my CV' company and position, a unique opportunity for a highly experienced programmer who is keen to learn and explore the new PSX 2 platform. Only candidates with an exceptional track record of programming no. 1 selling games need apply, or those who are currently working on the next no. 1 hit product.

A positive approach, coupled with an enthusiasm for working on new and groundbreaking ideas, open-minded and a 'can-do' attitude, are all key elements of the make-up required to be part of this unique team.

- Exceptional track record
- Published product
- 'Can-do' attitude

Ref 1884

### PSX 2 ARTIST

c£35k + benefits

An exceptionally creative and innovative artist with tremendous flair to work on the latest and most exciting PSX 2 games in the industry.

Our client is looking for individuals with a unique CV - a 'claim to fame' which competes with no others.

Your personality needs to be exceptional and your attitude open-minded, forward thinking, keen and creatively unique.

3DS Max skills are a must, as is texturing ability to the highest standard.

The company is a market leader, centrally located and offers comprehensive company benefits.

Please supply a showreel with CV.

- 3DS Max experience
- Proven track record
- Creative, innovative

Ref 2008



**PROGRAMMERS - YORKSHIRE AREA**

Caffeine Studios are a leading sports computer games developer based in Huddersfield. Following the success of 'Football World Manager' and due to expansion we are now looking for two experienced programmers to work on exciting new PC / Dreamcast projects.

**3D Programmer (PC)**

Programmer required to work on a 3D engine and character animation system. Must have 2+ years industry experience and a strong maths background. Knowledge of C/C++, D3D and working in a shared code environment advantageous.

**Programmer (PC)**

Experienced C/C++ programmer required to work on a new football management game. Must have industry experience, ideally gained in a Windows shared code environment.

To apply, please send CV's to :-

Daniel Blackburn (Ref:E04)  
Caffeine Studios Limited  
Kirklees Media Centre  
Huddersfield HD1 1RL

or e-mail :-

jobs@caffeine.co.uk



# Datascope

GAMES PEOPLE

## Programmers & Engineers

**PC Programmers x 2**

**W London; £High**

This company's latest game, Evolve, is totally original. It is a strategy shoot-em-up with creatures which mutate and grow. They change according to your abilities. Landscapes are visually breathtaking. artworks.co.uk. Position 1: C++, AI, 3D real time and Win32. Position 2: Direct3D, neural networks, artificial life and a science degree. **Ref: 790**

**PC Programmers**

**Manchester; £London wages in the North!**

Part of a public company, creating a premier product in the Manchester area. As well as C and PC skills, we require an interest in football (in other words this is a football game) **Ref: 807**

**Lead Programmer**

**Oxon; £Neg**

The UK marketing and development division of a major French publisher. Growing to 40 strong over the next year. An experienced games programmer with top notch all round technical skills and a good track record is required. Good 3D, W95 and DirectX essential. **Ref: 776**

## Artists & Animators

**Level Designer**

**W London; £18k + bonus**

One of the big names in games publishing and development. This company has recently completed a management buyout and is going places. We seek previous experience in level design. We need someone by May. **Ref: 819**

**Games Artist - Junior**

**London; Up to £20k**

They produced one of the most influential shoot-em-ups of the late 80's and are still at the forefront in the 90's. This represents a wonderful opportunity to work with a pedigree company with a track record of innovation. Artists with experience in 3D computer graphics, a formal graphics qualification and a title to their name are required for low pol. modelling, textures and animation. Character animation a bonus. **Ref: 720**

## Management, & other positions

**Director/Programmer**

**Scotland; £Neg**

A creative development house. Software ranging from children's educ. through games, for themselves as well as for others. 50+ staff, around a little over 5 years. Some titles include: Plane Crazy (pub. by Europress) and Wallace & Gromit funpack. A candidate from a multimedia background is required to fill this senior role working on new projects. **Ref: 763**

DATASCOPE

RECRUITMENT

Contact **Justin Hill** (programmers) or **Paul Wilkes** (artists and other)

### Datascope Recruitment

104 Great Portland Street,

Tel: 0171-580 6018

London W1N 5PE

Fax: 0171-580 6068

E-mail: info@datascope.co.uk

This is just a small selection. For hundreds more please visit:

[www.datascope.co.uk/datascope/](http://www.datascope.co.uk/datascope/)

WE NEED EXPERIENCED PEOPLE TO WORK ON

## INTERNATIONAL LICENSES

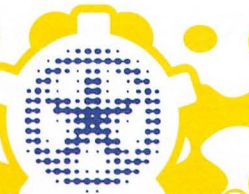

INNER WORKINGS™

### Programmers

Proven C/C++ Skills

### Testers

Eat, Sleep, Live Games

### Producer

Established Track Record

Contact:

Wendy Ellis

wendy@innerworkings.co.uk

Tel: +44 141 552 4451

Fax: +44 141 552 4427

www.innerworkings.co.uk

**DREAMCAST**  
IN STOCK NOW FROM £299.99

**DREAMCAST**

Virtua Fighter 3TB	£55.00
Pen Pen Tricelon	£50.00
Incoming	£55.00
Sonic Adventure	£55.00
Tetris 4D	£49.00
Sega Rally Champ	£55.00
Blue Stinger	£55.00
Power Stone	£59.99
House of the Dead (plus gun)	£4.00
Psychic Force	£59.99
Aero Dancing	£59.99
Rumble Pack	£4.00
RGB Scart Lead	£4.00

**DVD ZONE 1: Latest Releases**

Anti: Spec Ed. (LBX/AC3)	£23.99
Bride of Chucky. (LBX/AC3)	£19.50
Evil Dead: Spec Ed. (AC3)	£23.99
Fearist: Spec Ed. (LBX/AC3)	£19.50
I Still Know What You Did Last Summer	£20.99
Mighty Joe Young. (LBY/AC3)	£20.99
Robin: Spec Ed. (LBX/AC3)	£19.50
Rugrats: (LBX/AC3)	£20.99
Soldier: Spec Ed. (AC3)	£16.50
Truman Show: (LBX/AC3)	£20.99

Plus Many More! Next day P&P only £1.50 any size order!

**KRAZY KONSOLES • (Est 1990) •**  
PO BOX 200, HALIFAX, WYORKS, HX1 3PD •  
Hotline: 01422 342 901

**HYDROPONICS**  
GROW LIGHTS  
GROW SYSTEMS



Grow your favourite plants all year round...!

Free catalogue & Mail order  
01483 596484  
0958 698152

Fully equipped Shop & Grow-room  
Esoteric Hydroponics  
8 Martyr Road, Guildford,  
Surrey, GU1 4LF  
[www.blunt.co.uk](http://www.blunt.co.uk)

**EDGE**

To advertise  
call Amar Hussain on 0171 317 2645  
or Fax: 0171 486 5678  
or Email: amar.hussain@futurenet.co.uk

**WANTED**

**FOR CASH OR EXCHANGE**  
**CONSOLES**  
**COMPUTERS**  
**GAMES**

**RETRO & MODERN**  
**COMPUTER & GAMES EXCHANGE**  
65 Notting Hill Gate, London W11 3J5 ☎ 0171 221 1123

**BUY • SELL • TRADE**  
**POSTAL SERVICE AVAILABLE**

Also buy, sell, trade at MVE, Manchester Arndale Centre  
(by High St entrance) ☎ 0161 839 0677

**BOTH SHOPS OPEN 7 DAYS**  
Please bring official ID with address & signature when selling/exchanging

**ENORMOUS SELECTION ON SALE**

Est. 1991

**Nintendo 64**  
**Sony PlayStation**  
**Sega Dreamcast**  
**Saturn**

New and secondhand UK & Import Games  
Mail order or come into our shop

**CA GAMES**

De Courcy's Arcade, Cresswell Lane,  
Hillhead, Glasgow G12 8AA  
<http://www.cagames.co.uk>  
[cagames@intonet.co.uk](mailto:cagames@intonet.co.uk)  
Tel 0141 334 3901

**Game Gizmo** For all your console needs!

**PSX Game Enhancer:** play all your imports & backups without a modchip! Inc universal cheat cart & CD viewer **£19.99**

- Replacement PSX Laser £35.00
- Sony Dual Shock Pad £14.99
- PSX Official Memory Card £6.00
- 240 Block Card £12.99 + 480 Block Card £18.99
- VCD Player: watch films on your PlayStation! £54.99
- Scart Lead with audio cables £3.00
- Scart Lead with Gunco connection £9.50
- PSX NTSC to PAL Converter Box £15.00
- PSX Scorpion Light Gun £16.99
- Game Enhancer PAL Converter £34.99
- Game Enhancer Scart Pack £24.99

**DREAMCASTS**  
Dreamcasts, games and accessories all in stock now

Call for the best deal and package

CALL FOR FURTHER DETAILS ON THESE AMAZING ITEMS!

We will beat any price on our items!  
Free first class delivery on all orders!

We also stock the latest imported games and many other items at unbeatable prices.

Trade enquiries welcome  
Call 0181 3031996 or visit our website at: [www.gameenhancer.co.uk](http://www.gameenhancer.co.uk)  
Cheque/PO payable to: Game Gizmo, PO Box 8, Belvedere, Kent, DA17 5ZS

[www.projectk.com](http://www.projectk.com) Email: [info@projectk.com](mailto:info@projectk.com) TEL: 0181 508 1328  
FAX: 0181 508 3845

**PROJECT K**  
PLAYSTATION IMPORTS DREAMCAST IMPORTS BEATMANIA POCKET

REPLACEMENT PSX LASER £30  
Street Fighter Zero 3 £49.99  
Ehrgeiz (Squaresoft) £51.99  
Panora the Rappa 2 £46.99  
Tenchu Ninja 2 £41.99  
Shogun Assassin £46.99  
Broke Fencer (Squaresoft) £46.99  
Xenogears (Squaresoft) £47.99  
Silent Hill £47.99  
Lunar Silver Star Story £16.99  
Mentah £16.50  
Pal Booster

**PSYCHIC FORCE** £51.99  
**SEGA RALLY** £47.99  
**VIRTUA FIGHTER 3** £47.99  
**ZINOMADO 4D** £47.99  
**TETRIS 4P** £47.99  
**POWERSTONE** £47.99

**NINTENDO 64 IMPORTS**  
4 Meg High Res Pak £24.99  
Zelda Castlemania Turb 2 £24.99  
Smash Brothers Mario Party

**SATURN 2 in 1 Cart** (un import)  
games incl Rom games £35  
Plug & Play, no conversion!  
DUNGEONS AND DRAGONS COLLECTION IN STOCK

**PROJECTORS & DVD IMPORTS**  
10 Inch LCD Projector £299.99  
ALL Region Pioneer DVD Player £399.99  
Waking Pokemon Toy £7.99  
Pokemon Cuddly Toy £9.99  
9 Inch Fully Painted Models From £5.99  
Final Fantasy VII Music CD £11.99  
Dracula X Remix Music CD £2.99  
Final Fantasy VII Posters EACH £1.99  
Xenogears Music CD £11.99

**MERCHANDISE IMPORTS**  
Final Fantasy VII Music CD £11.99  
Dracula X Remix Music CD £2.99  
Final Fantasy VII Posters EACH £1.99  
Xenogears Music CD £11.99

For a free price list of imported games, accessories and merchandise send a SAE to PROJECT K, The Seedbed Centre, Langston Road, Loughton, Essex, IG10 3TQ

**NEW GENERATION**  
TEL: 0113 230 6007 or 0113 230 2732  
Open: Mon-Sat 10am-7pm, Sun 12pm-5pm  
<http://www.newgeneration.demon.co.uk/index.html>

**IMPORT TITLES**

<p><b>JAP DREAMCAST</b></p> <ul style="list-style-type: none"> <li>Aero Dancing</li> <li>Blue Stinger</li> <li>Evolution</li> <li>Get Bass</li> <li>Godzilla</li> <li>House of the Dead 2</li> <li>Incoming</li> <li>Marvel Vs Capcom Monaco GP</li> <li>Pen Pen Tricelon</li> <li>House of the Dead 2</li> <li>Powerstone</li> <li>Psychic Force 2012</li> <li>Sega Rally 2</li> <li>Shenmue</li> <li>Sonic Adventure</li> <li>Super Speed Racing</li> <li>Virtua Fighter 3tb</li> </ul>	<p><b>U.S./JAP PLAYSTATION</b></p> <ul style="list-style-type: none"> <li>Beatmania 3rd Mix (JAP)</li> <li>Beatmania Controllers</li> <li>Bloody Roar 2 (JAP)</li> <li>Chocobo Racing (JAP)</li> <li>Capcom Generations 1-5 (JAP)</li> <li>Ehrgeiz (JAP)</li> <li>Final Fantasy 8 (JAP)</li> <li>Metal Gear Solid (U.S./JAP)</li> <li>Pop n' Music (JAP)</li> <li>Ridge Racer Type 4 (JAP)</li> <li>Silent Hill (U.S./JAP)</li> <li>Sports Car GT (U.S)</li> <li>Streetfighter Zero 3 (JAP)</li> <li>Syphon Filter (U.S)</li> <li>Tenchu 2 (JAP)</li> <li>Umjama Lammy (JAP)</li> </ul>	<p><b>U.S./JAP NINTENDO 64</b></p> <ul style="list-style-type: none"> <li>California Speed (US)</li> <li>Castlevania (US)</li> <li>Extreme G 2 (US)</li> <li>Fifa 99 (US)</li> <li>Mario Party (US)</li> <li>Milo's Astro Lanes (US)</li> <li>Rogue Squadron (US)</li> <li>Shadowman (US)</li> <li>Smash Bros. (JAP)</li> <li>Snobow Kids 2 (JAP)</li> <li>South Park (US)</li> <li>Star Shot (US)</li> <li>Vigilante 8 (US)</li> <li>Wipeout 64 (US)</li> <li>Zelda (US)</li> </ul>
<p><b>US PLAYSTATION RPG'S</b></p> <ul style="list-style-type: none"> <li>Alundra</li> <li>Azure Dreams</li> <li>Brave Fencer Musashi</li> <li>Breath of Fire 3</li> <li>Final Fantasy 7</li> <li>Final Fantasy Tactics</li> <li>Granstream Saga</li> <li>Guardian's Crusade</li> <li>Kartia</li> <li>King's Field 2</li> <li>Legend of Legaia</li> </ul>	<p><b>US SATURN RPG'S</b></p> <ul style="list-style-type: none"> <li>Parasite Eve</li> <li>Saga Frontier</li> <li>Tactics Ogre</li> <li>Tales of Destiny</li> <li>Wild Arms</li> <li>Xenogears</li> <li>Lunar: Complete</li> <li>Magic Knight Rayearth</li> </ul>	<p><b>HARDWARE</b></p> <p><b>DREAMCAST</b></p> <ul style="list-style-type: none"> <li>Joystick</li> <li>PAL Converter</li> <li>RGB Cable</li> <li>Rumble Pack</li> <li>Steering Wheel</li> <li>S-Video Cable</li> <li>VMS Memory Card</li> </ul>

New releases arriving on all systems daily - Ring for details - Best deals on part exchange - Many back catalogue titles for all systems - Trade enquiries welcome - Next day delivery available - Established 8 years - Visit us at: 3 The Parade, Stonegate Road, Meanwood, Leeds, LS6 4HZ. Also at: 10 Mill Hill, Leeds, LS1 5DQ. TEL: 0113 234 1116. All copyrights respected. Hello!

**BE AWARE: CHIPPING VOIDS ANY SONY UK WARRANTY ON YOUR PLAYSTATION. PROCEED AT YOUR OWN RISK.**

# THE KART KLUB EST 1994

## BUY - SELL - TRADE

1000s of games in stock including:



**SEGA**

- Mastersystem
- Megadrive
- Gamegear

**Nintendo**

- Gameboy
- Supernintendo
- Nes

13 THE ARCADE, LITTLE WELLINGTON ST, ALDERSHOT, HANTS GU11 1EE  
Open 10.00am-6.30pm Mon-Fri • 9am-5.30pm Sat  
(Also at Blackbushe Market, Row M1288 Sunday)

**Tel: 01252 343737**

(Please Note: We have now changed address)



# RETRO



**BUY - SELL - EXCHANGE  
ALL THE BEST RETRO  
TO SATISFY ANY  
GAMER OR COLLECTOR**



143 Whitfield Street **EUSTON ROAD**  
London W1P 5RY

**Tel: 0171 692 1213**

Open: Mon, Tue, Thur, Fri, Sat: 10am-5.30pm  
Wednesdays: 10am-1pm Closed on Sunday.



**LONDON'S GAMES MUSEUM**

**SNK WE STOCK AND PAY TOP PRICES FOR:**



King of Fighters 98, Zelda 1 & 2, Manic Miner, Elite, Donkey Kong, R-Type, Star Wars, Space Invaders, Pac Man, Pong, Bomb Jack, Mr. Do!, Strider, Street Fighter, Pole Position, Metal Gear 1 & 2, AVP, Spike, Commando, Gadius, Dune, Dizzy, Chaos Engine, Yie Ar Kung Fu, Konami Ping Pong, Pitfall, Super Mario Bros, Jetpac

3DO, Amstrad CPC/GX4000, Arcade PCB, Atari 2600/7800/XE Cart, Colecovision, Commodore 64/VIC 20, Dragon 32, Game & Watch, Game Gear, Intellivision, Jaguar, Lynx, Master System 1/Mk III, Megadrive, 32X/Mega CD, MSX, Neo Geo/Neo Geo CD, Nes/Famicom, PC Engine, Videopac, Super Famicom, ZX Spectrum, Vectrex, Virtual Boy



**ATARI**



**MEGA DRIVE**

**AND MORE!  
ULTIMATE PLAY THE GAME  
VECTREX**

**VISIT THE SHOP OR MAIL ORDER**

**WORLD'S BEST!!  
BEWARE OF LIMITATIONS.**



I.D. REQUIRED FOR ALL SELLERS OF STOCK.

ALL TRADEMARKS RESPECTED.

**DC**

Shenmue  
Get=Bass  
Blu=Stinger  
Buggy=Heat  
House of  
Dead 2  
S=Rally2  
PowerStone  
RE=Veronica  
SPUR=OS

**£199** Best price in town guarantee!

PS2 GAME Enhancer plays all US, JAP, PAL import titles on any PS PC port. 100 cheatslots actionplay cheats

PS designo-colors £35

PSZ

£191

PSZ GAME Enhancer plays all US, JAP, PAL import titles on any PS PC port. 100 cheatslots actionplay cheats

Latest imports games and hardware from Japan, USA, HK, DC, PSX, N64, GB-Color, DC-VMS, Pokt-Station, NeoPocket Latest All-region DVD Players DTS/AC3, MD-Walkman UK Next-day delivery on stock items, 1-3 days for European orders, Trade enquiries welcome

RGB-SCART, S-Video cable, VGA-box, Virtua Stick Steering wheel, keyboard, colour pads, VMS Light-Gun, Jap-modem or HK versions, Latest DC games from Japan, available next-day Portables DVD Panasonic L10, Sony V30 All-region DVD players S7700, M35 Toshiba Sd2108 w/DTS

**Playtronix** 01329-312200  
Multimedia Entertainment 07887-788886

18 Palmerston Business Park, Newgate Lane, Fareham, Hampshire PO14 1DJ  
email: playtronix@cwcom.net http://come.to/playtronix Fax: (+44)-1329-312211

ドリームキャスト

# Dreamcast Ltd

Tel: 0113 274 2003 OR 0113 274 2006

<http://newgeneration.demon.co.uk>



The Sega Dreamcast. The most powerful console on Earth. 128bit technology, 16 megabytes of main memory, hi-res display & 3 million polygons per second! This is the future of video games!



SEGA RALLY 2



SONIC ADVENTURE



POWER STONE



HOUSE OF THE DEAD 2



BLUE STINGER



MARVEL Vs CAPCOM

**OTHER TITLES**

- Aero Dancing
- Buggy Heat
- Godzilla
- Incoming
- Monaco Grand Prix
- Pen Pen Tricelon
- Pop N' Music & Controller
- Psychic Force 2012
- Puyo Puyo
- Super Speed Racing
- Tetris 4D
- Virtua Fighter 3tb

**PERIPHERALS**

- Arcade Joystick
- Arcade Racing Wheel
- Joypad
- PAL Converter (Runs on any TV)
- RGB Cable
- Rumble Pack
- S-Video Cable
- V.M.S Memory Cards

All copyrights respected. Hello!



We are a sister company of New Generation Consoles and have been established 8 years. Visit us at 3 The Parade, Stonegate Road, Meanwood, Leeds, LS6 4HZ. Complete range of games for all systems available on import & domestic.



# Games Console

Official PlayStation Centre  
Phone 07000 PlayStation (752978)  
Import Software at Meltdown Prices



Hexen, Doom, Waverace, Blast Corps, F1 Pole Position, Chameleon  
Twist, Clayfighter, MRC, Mario Kart, Extreme G, War Gods  
All American £19.99 each



USA/JAP Gran Turismo £19.99, Bushido Blade 2 £34.99  
Huge stock available at £30.00 each

## National & International Mail Order



Dreamcast: Virtua Fighter 3TB, Sega Rally 2, July,  
Pen Pen, Godzilla Generations



Nintendo 64: Zelda 64, Shadowman, Body Harvest,  
Castlevania 64, Hybrid Haven



PlayStation: Final Fantasy VIII, Tomb Raider III

First with all import software



PlayStation, Nintendo 64, Dreamcast,  
DVD (Movies & Players), PC CDROM,  
Gameboy, (UK/USA/JAP)



160 Fleet Road, Fleet, Hampshire. GU13 8BE  
Tel: 01252 810649 Fax: 01252 810650  
<http://www.games-console.com>  
email: [info@games-console.com](mailto:info@games-console.com)



# Maxking Interfaces Ltd

FREE PHONE ORDER LINE: 0808 100 2393

FAX ORDER LINE: 01302 820885

Email: [maxking@maxking.com](mailto:maxking@maxking.com)

Internet site: <http://www.maxking.com>

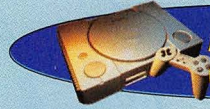

All prices below include  
delivery and VAT



1-9 12C508 UN PROGRAMMED CHIP .....	£1.17 EA	PLAYSTATION MULTI-TAP .....	£17.00
100+ 12C508 UN PROGRAMMED CHIPS .....	£0.89 EA	AV-GUN CON ADAPTER .....	£8.00
COLMOD BOARD WITH 12C508 CHIP .....	£10.00	ARCADE STEERING WHEEL & FOOT PEDALS .....	£35.00
SMART 2 PAL TO NTSC CONVERTER (V2) .....	£10.00	PSX DELUXE HARD CARRY CASE .....	£20.00
1MB MEMORY CARD FOR PSX (15 SLOT) .....	£6.00	TEKKEN 3 CHEAT MASTER CARTRIDGE .....	£10.00
2MB MEMORY CARD FOR PSX (30 SLOT) .....	£12.00	NINTENDO CD64 CD UNIT .....	£200.00
4MB MEMORY CARD FOR PSX (60 SLOT) .....	£16.00	NINTENDO 64 GAMES CONSOLE .....	£95.00
9MB MEMORY CARD FOR PSX (135 SLOT) .....	£18.00	NINTENDO 64 HYPER 64 CONTROLLER .....	£16.99
RGB SCART CABLE FOR PSX WITH GUN PORT .....	£4.00	NINTENDO 64 JOLT PAK .....	£11.99
PSX/SATURN SCORPION LIGHT GUN .....	£17.00	NINTENDO 64 JOLT PAK WITH 1MB .....	£14.99
BASIC JOYPAD FOR PSX MACHINE .....	£5.00	NINTENDO 64 256K MEMORY .....	£6.99
JOYPAD DUO CYBER SHOCK FOR PSX .....	£17.00	NINTENDO 64 1MB MEMORY .....	£12.99
INFRA RED CONTROLLERS FOR PSX (PAIR) .....	£20.00	NINTENDO 64 8MB MEMORY .....	£15.99
EXPLORER CHEAT CARTRIDGE .....	£20.00	NINTENDO 64 SCART CABLE .....	£6.00
EXPLORER COINS LINK .....	£10.00	NINTENDO 64 S-VIDEO CABLE .....	£5.00
HYPER MOUSE FOR PSX MACHINE .....	£8.50	NINTENDO 64 AV CABLE .....	£5.00
MOVIE PSX ADDON (VCD UNIT) .....	£45.00	NINTENDO 64 X-TENDER CABLE .....	£6.00
SMART PRO CHEAT CARTRIDGE .....	£13.00	NINTENDO RP UNIT .....	£10.00
SMART PRO COINS LINK .....	£25.00	NINTENDO SFX V3 GAME CONVERTOR .....	£10.00
CONTROLLER EXTENSION CABLE .....	£6.00	NINTENDO 64 SCART CONVERTOR .....	£19.99
SYSTEM LINK CABLES .....	£6.00		

HOURS: MON-FRI 9AM TO 5PM

SEND MAIL ORDER DETAILS TO:

22 CHURCH STREET, BENTLEY, DONCASTER,  
SOUTH YORKSHIRE, ENGLAND, DN5 0BB



**FANTASY WORLD**  
10 MARKET SQUARE ARCADE, HANLEY, STOKE ON TRENT, ST1 1NU

IMPORT & UK MAIL ORDER  
YOU CAN VISIT US AT THE ABOVE ADDRESS

TEL: 0498 897770 OR 01782 279294

<b>PLAYSTATION</b> FINAL FANTASY 8 SILENT HILL MARVEL VS STREETFIGHTER EX ERETZVJUI DEEP FREEZE BLOODY ROAR 2 OPTION TUNING CAR 2 CHOCOBO DUNGEON 2 RIDGE RACER TYPE 4 TALES OF PHANTASIA LUNAR SILVER STORY COMPLETE XENOGears TALES OF DESTINY SYPHON FILTER CARMAGEDDON 2 SOUL REAVER CHOCOBO RACING KING OF FIGHTER 98	UNJAMMA RAMMY CYBERORG FINAL FANTASY COLLECTION LAST BLADE (SHK) POP N MUSIC MONKEY HERO <b>NEW IMPORT PLAYSTATION</b> COLL FINAL FANTASY ANNIVERSARY ATHENA UNJAMMER LAMMY (PARAPPA 2) CHOCOBO RACING GALLOP RACER 3 KING OF FIGHTERS 98 RISING ZAN-SAMURAI GUNMAN CYBERORG (SQUARE) SAGA FRONTIER 2 ALL JAPAN PRO WRESTLING KINGS SPIRIT COTTON ORIGINAL	<b>SEGA SATURN</b> ERANDOLL RADIANT SILVERGUN CAPCOM GENERATIONS VOL 1-6 SHINING FORCE 3 SCENARIO 2 SHINING FORCE 3 SCENARIO 3 KING OF FIGHTERS COLLECTION (95, 96, 97 + RAM) MARVEL VS STREETFIGHTER X-MEN VS STREETFIGHTER MAGIC KNIGHT RAY EARTH METAL SLUG SONIC 3D FLICKY'S ISLAND GRANDIA + MEMORIAL POWERDRIFT DUNGEONS + DRAGONS COLLECT	QUAKE 2 CASTLEVANIA HYBRID HEAVEN ZELDA SOUTH PARK SMASH BROTHERS ROGUE SQUADRON DISNEY'S TETRIS SHADOWGATE CONKER 64 SNOWBOARD KIDS 2 CALIFORNIA DREAMIN TOUNKEN ROAD 2 WRESTLING <b>COLOUR NEO GEO POCKET</b> CONSOLE & GAMES <b>WONDER SWAN</b> <b>HANDHELD</b> CONSOLE & GAMES
--	---	--	---

<b>GAME MUSIC</b> SAGA FRONTIER, PARASITE EVE, TEKKEN 3, BRAVE FENCER, FINAL FANTASY TACTICS OVER 100 TITLES IN STOCK	<b>IN STOCK NOW</b> NEOGEO POCKET £49.99 BASEBALL, SOCCER, TENNIS, KOF R-1, SAMURAI SPIRIT, PUZZLE ACE HEADSET, LINK NINTENDO COLOR GAMEBOY PLUS 4 NEW GAMES
---	---

**WE ALSO TRADE AS ANOTHER WORLD**  
 NOTTINGHAM: 11 MARKET STREET Tel: 0115 948 4122  
 DERBY: 42/43 CASTLEFIELDS, MAINCENTRE Tel: 01332 206 606  
 LEICESTER: 23 SILVER STREET Tel: 0116 251 5266  
 WOLVERHAMPTON: 23 VICTORIA STREET Tel: 01902 717 440

THOUSANDS OF NEW AND USED GAMES IN STOCK  
 Ask for Colin Dimond on ALL IMPORT QUERIES

NEW WEBSITE:  
[www.anotherworld.co.uk](http://www.anotherworld.co.uk)  
 e-mail: [sales@anotherworld.co.uk](mailto:sales@anotherworld.co.uk)



Mail Order Hotline  
 01252 816677  
 Shop  
 01252 816088

**INSOMNIA**

**£324.99**  
 All Dreamcast games under  
**£54.99**

Console, p.s.u & 1 game ready to run  
 includes all leads

most major credit cards accepted  
 Please send all cheques / PO's to (made payable to insomnia);

7 Crookham road, Fleet, Hampshire  
 GU13 7DP



**EVOLUTION**  
TECHNOLOGY FOR THE NEW AGE

DC LATEST: SHENMUE/BUGGY HEAT  
HOD2+GUN/MARVEL VS CAPCOM  
CALL FOR NEWEST RELEASES  
DVD REGION 1+2 MOVIES AVAILABLE  
ALL MAJOR CONSOLE FORMATS SUPPORTED

TEL: 01924 366203  
FAX: 07079 015398 e-mail: evolution@btconnect.com  
Check out our secure online store and website:  
[www.evotna.co.uk](http://www.evotna.co.uk)

**MASTER-CART**  
CONSOLES & GAMES UK  
DERBYSHIRE'S PREMIER STOCKISTS OF ALL LEADING CONSOLES & GAMES

**PSX'S MODIFIED WHILE YOU WAIT!**  
SEND S.A.E FOR FULL DREAMCAST PRICE LIST

WE'VE GOT 100'S OF NEW & PRE-PLAYED GAMES IN STOCK ALL AT DISCOUNT PRICES, INCLUDING EACH WEEK'S NEW RELEASES.  
NO EXCHANGE FEE CHARGED ON GAMES WHEN THE GAME YOU'VE GOT IS WORTH THE SAME AS THE GAME YOU WANT, IT'S FREE!  
COME & SEE OUR GAMES UNIT!  
UNIT 22, THE MARKET HALL,  
CHESTERFIELD, DERBYSHIRE S40 1AR

TEL: 01246 232645  
EMAIL: MASTERCART@KOL.COM

**LOADED**  
32 Pound Road, East Peckham, Tonbridge, Kent, TN12 5BE  
\*First with imported games and machines\*

NEO GEO  
Neo Geo CD Pack (CD2/PAL/NTSC) ..... £Call  
Back Catalogue Games ..... £29.99 - £59.99  
Pocket Neo Geo ..... Ring For Details  
New Releases: Metal Slug 2, Breakers Revenge, King of Kings, Read Bout II: The Newcomers, King of Fighters 98, Last Blade 2  
We also stock a range of Neo Geo CD and Cart Kit  
New Range of Japanese Cartridges in stock -  
\*\*VERY COLLECTABLE\*\* ..... £Please Call

WANTED: USED NEO GEO CD & CARTRIDGE KIT- TOP PRICES PAID!

We stock hardware for these formats from around the world. Import machines come ready to play with Scart cable and 240V PSU ..... £Please Call  
N64 New releases... Zelda 64, Castlevania 64, Mario Party, Smash Brothers (and many many more) also available in stock now  
SATURN White Saturn, Video CD Saturn,  
Cool Saturn ..... £Call  
New releases: Capcom Generations 485, Marvel Superheroes VS Street Fighter - massive range  
PLAYSTATION New releases: Soul Reaver, Silent Hill, Final Fantasy VIII, Ridge Racer 4, Parappa the Rapper 2 and many more

WE WILL BEAT ANY PRICE QUOTED FOR DREAMCAST IN THE UK!

DREAMCAST... The next generation in video gaming Games to include... King of Fighters, Sonic Adventure, Blue Stinger, Virtua Fighters 3TB, Monaco Grand Prix, House of the Dead 2, Marvel vs Capcom, Aero Dancing, Buggy Heat and many more as they are announced!

**SEGA SATURN CONVERSION**  
PLAY ANY GAME FROM ANY TERRITORY AT ANY SPEED... £CALL FOR A PRICE

Tel/Fax **01622 871551**  
9.00am - 6.30pm

**DREAM-TEK**

DREAMCAST + STEPDOWN + VMS + SONIC or VF3 + 1 FREE MYSTERY TITLE + ENGLISH MANUAL + ENGLISH VMS GUIDE + ENGLISH MODERN INSTRUCTIONS + 12 MONTHS RETURN-TO-BASE WARRANTY + RGB SCART CABLE  
**JUST £3??..??**  
AVAILABLE ON IMMEDIATE NEXT DAY DELIVERY  
DREAMCAST SPECIAL + MONACO GP + RUMBLE PACK - £74.99 WITH MACHINE, £84.99 SEPARATE

THIS MONTH  
DREAMCAST = SHENMUE, GEIST FORCE, HOUSE OF THE DEAD 2, MARVEL VS CAPCOM, WILD METAL  
SATURN = TAKEGI GRAPH (SAKURA WARS 3), DUNGEONS & DRAGONS, LANGRISSE SPECIAL, ERANDOLL  
N64 = V-RALLY, VIGILANTE 8, STAR SHOT, CASTLEVANIA  
PSX = WILD ARMS 2, POCKETSTATION, BLOODY ROAR 2, DEEP FREEZE, FF 4-6 COLLECTION

**SPECIAL OFFER:**  
SPEND £100 AND RECEIVE A FREE MYSTERY TITLE FROM US - OFFER APPLIES TO N64, PSX & SATURN ONLY  
**SATURN CONVERSIONS £35 - 50/60Hz, USA/JAPIUK SWITCH INCL.**  
FREE ENGLISH LANGUAGE GAME GUIDES WHEN YOU BUY YOUR GAME FROM US (WHERE AVAILABLE), WE HAVE APPROXIMATELY 200 ACROSS ALL PLATFORMS, AVAILABLE FROM £4.99

DREAM-TEK, 1A PITGREEN LANE, NEWCASTLE UNDER LYME, NORTH STAFFORDSHIRE ST5 0DQ  
OPENING HOURS 10AM-6PM MON-SAT, 10AM-2PM SUN  
**01782 878805**  
EMAIL US AT: DREAMTEK@X-STREAM.CO.UK

Est 1992

**3DO NINTENDO Y G A PC**

**COMPUTER & VIDEO GAMES IMPORTS AND EXCHANGE**

ALL MAJOR CREDIT CARDS ACCEPTED

9 Wilton Parade, High Street, Feltham, Middx. TW13 4BU  
\* Open 10-6 Monday-Saturday \* Closed Wednesday  
\* Open 12-4 Sunday  
☎ 0181 893 2100/844 2575 ☎ 0181 844 1944  
AFTER HOURS LINE 6PM-10PM 0973 552398

**RETROGAMES**  
The World's First Classic Software & Hardware Retailer

**Official Shop Now Open**  
OVER 5000 GAMES AND MACHINES IN STOCK

RETROGAMES "The Shop" is managed by Jason Moore, self-proclaimed "Guru of old stuff", and author of N64 magazine's RetroWorld column, so you're guaranteed to find all the information you need on games of the past. You can also buy current and back issues of Retrogames the magazine, the world's best-selling Retro Publication.

**ISSUE 17 OUT NOW!**  
Retrogames - The Shop  
47 Church Road, Hendon, London NW4  
0181 203 8868 : Email: RETROBLOKE@aol.com

Retrogames - Mail Order  
Cheques & Postal Orders made payable to 'J Moore' c/o:  
Retrogames, 61 Baccara Grove, Bletchley, Milton Keynes MK2 3AS

**HOW TO GET THERE!**  
J2: Turn right at first traffic lights, turn right at next traffic lights. Look out for us on your left.

**DO YOU WANT TO PLAY... OR BE A PLAYER?**

ACCREDITED 3D STUDIO MAX TRAINING FOR GAMERS WHO WANT TO MOVE ONTO THE NEXT LEVEL

3 DAY INTENSIVE COURSES £330 + VAT

T:0171 729 9992 F:0171 739 7742 E:info@mnm.co.uk  
35 KINGSLAND ROAD SHOREDITCH LONDON E2 8AA  
[www.mnm.co.uk](http://www.mnm.co.uk)

metro new media

design rebecca foster 0171 242 6702

**GAME FRONT**  
your source for the cheapest products around  
PO BOX 83, MANCHESTER M14 6ET  
TEL: 0700 2020020 FAX: 0700 2030020  
WWW.GAMEFRONT.CO.UK EMAIL: MAIL@GAMEFRONT.CO.UK

**DREAMCAST: CALL FOR LATEST PRICE**  
THIS MONTH'S SPECIAL... FREE choice of any VCD with each VCD card!!!  
FULL RANGE OF VCD'S AVAILABLE... £14.99

**PSX LASER UNIT**  
WE HAVE STOCK **£34.99**

Mod Chip (Buy 1 Get 2 Free)...£14.99  
NTSC-PAL Converter..... £14.99  
VCD Adaptor Card..... £59.99  
1M Sony Memory Card.....£7.99  
Panther Light Gun.....£14.99  
Foot Pedal for Panther..... £6.99  
Sony Dual Shock Pad..... £17.99  
Street Fighter Zero 3 (JAP)...£49.99  
Bushido Blade 2 (USA)..... £49.99  
Keno Gears (USA).....£49.99  
Brave Fencer (USA).....£49.99  
Final Fantasy 8 (JAP)..... SCALL

**PSX CHIP CARTRIDGE**  
Play import games without mod chip £14.99  
QTY Discounts available.

**DREAMCAST**  
Joypads-£29.99  
VMS-£24.99  
Virtua Fighter 3tb  
Sega Rally 2  
Sonic Adventure  
Blue Stinger  
Pen Pen Tricelon  
Power Stone

**GAMES ALL £49.99**

TRADE PRICING AVAILABLE ON ALL PRODUCTS!!!  
Same merchandise (wall scrolls, keychains, posters, figures) and other JAP goodies available. Please send a S.A.E to mail order address above for full price list.

Why not visit our shop, NEW EAST GAMES at:  
87 Princess Street, Manchester, M1 4MT  
TEL/FAX: 0161-228 0070  
**\*\*SHOP PRICES MAY VARY FROM MAIL ORDER\*\***

**GAMETRON EXCHANGE**  
56A King Street, Cambridge, CB1 1LN  
Tel/Fax: 44+(0)1223 462 825

**THE LATEST IMPORT & UK RELEASES**  
WE BUY, SELL, EXCHANGE.

**DREAMCAST, NINTENDO 64, PLAYSTATION, DVD SYSTEM, NEO GEO CD, P GAMEBOY.**

**DREAMCAST CALL**

Trade & wholesale prices please fax  
Tel/Fax: 44+(0)1223 462825  
Email: GAMETRONIX@yahoo.com

**SKILL** **0181-567-9174**  
IMPORT-NINTENDO & PLAYSTATION  
EST. 1993 9AM-8PM 7 DAYS A WEEK

Dreamcast...  
£264.99

**NINTENDO 64**  
USA  
£114.99

ROGUE SQUADRON  
SMASH BROS  
BEETLE ADV RACING  
TONIC TROUBLE

SHADOW MADNESS  
SILENT HILL  
LUNAR SILVER STAR

MARVEL VS CAPCOM  
HOUSE OF THE DEAD  
BLUE STINGER

ALSO AVAILABLE SECOND-HAND GAMES FROM £11.99

"The best mail order import establishment in the UK today" (www.n64hq.com)  
**0181-537-8297 / 0181-567-9174**  
P.O BOX 5913, EALING, LONDON W13 9ZX



FEW DEVELOPERS CAN BE SMALLER THAN THE LATEST SPLINTER GROUP FROM BULLFROG – BUT THEN THESE ARE EARLY DAYS FOR A TEAM WHOSE COMPELLING APPRECIATION OF CREATIVITY AND

an audience with...

# lost toys

ORIGINAL IDEAS SPEAKS MORE THAN SHEER SIZE EVER COULD

It would appear that Bullfrog has unwittingly become the spawning ground for some of the industry's hottest break-off outfits. Previous departees Mucky Foot (current project: *Urban Chaos*) and Lionhead Studios (*Black & White*) are now joined by Lost Toys, currently a three-man outfit comprising **Glenn Corpes** (coder; CV highlights: *Populous*, *Powermonger*, *Magic Carpet*, *Dungeon Keeper*), **Jeremy Longley** (coder; CV highlights: *Theme Hospital*, *Syndicate Wars*, *Populous III*) and **Darran Thomas** (artist; CV highlights: *Theme Park 2*, *Magic Carpet 2*, *Dungeon Keeper*). As **Edge** recently discovered, the fledgling upstart has some refreshing approaches to development...

**Edge:** How did you go about putting together a break-off team?

**Jeremy Longley:** As it turns out, the three of us have been in the pub every Friday night. We've been good friends – drinking partners, if you like – for years. For the last three months I've been worked off my feet arranging the business side of it, and I've only just got together with Glenn and Darran to form the company.

**Edge:** Were you spurred on by the whole break-off trend?

**JL:** It's encouraging to see other people doing it successfully, definitely; it proves that it can be done. It's a risky business, but once you collect together enough talent and experience, then it cuts the risk down significantly.

**Glenn Corpes:** I don't think that it's a trend, particularly; I think it's sort of cyclic. People split off, and then publishers buy them back after a while. Lionhead started up a year ago, Mucky Foot was set up two years ago, and both were created for similar reasons, so it's hardly a fashion thing.

**Edge:** We haven't yet seen any finished products from those companies you mention, so in some respects there's still a lot to prove...

**JL:** Well, we've still got to write a game – that's the point, we're here to write games. We want to make games that people will want to play and enjoy – and buy – hopefully.

We see a lot of teams producing really ambitious games, they want to take on *Half-Life*, *Tomb Raider* and *Zelda*, they're going to go for it and produce the biggest, most impressive game. And then there are games that you can write that are fun, that are worth buying, but that are easier to write. You don't *have* to take on every aspect, you don't *have* to be a leader of technology, a leader of game design and a leader of all the other things to make a game that's good and fun, and absolutely up-to-date and worth the money. So, if you make life easy for yourself, then you're only helping yourself out. There are a lot of risks involved in setting up a company, and if you can eliminate some of them by taking one particular aspect, using something that you've learned, some game design skills, you can put those together to make it easier.

**GC:** It seems as though a lot of companies that set up have got the best people, they've got a lot of technical expertise and they want to prove to their publishers that they can technically keep up with the best – I think every small company wants to be another id, basically – and it seems that we've got game ideas that don't require us to prove ourselves technically. Don't get me wrong, though – we can do the technical stuff. For the last year and a half, in fact, Jez and I have been working on stuff which is groundbreaking 3D technology, using level-of-detail stuff straight out of last year's Siggraph-published research, and rigid-body physics which is up there with the likes of *Carnageddon*. EA was into the fact that we had this cool graphics technology, but the producer and designer types there were more worried about storyline and character design than the basic, original gameplay category. It's actually easier to be original than it is to be the best in one area. We believe that the differentiation is as important as originality, and more important than proving technical ability.

**Darran Thomas:** We definitely want to compete on a creative level rather than a technical one. We don't want to get into a bullet-point war – y'know, fastest 3D engine, etc – we want people to play our games, and rather than thinking, 'Well, that's a really flash 3D engine', we want them to think, 'This is really fun to play'. That's definitely what our emphasis is going to be when making our own games.

**JL:** One of the things we're going to do right from the start is get something that's fun to play. Generally, you write an engine, then you have to write 3D navigation, and then AI, before the game is fun, and if you're a year down the road and you haven't even worked out whether your game is fun or not, then you could be in all sorts of trouble. The first thing we do is whatever it takes to make the game fun – so you can pick it up and play it. After that

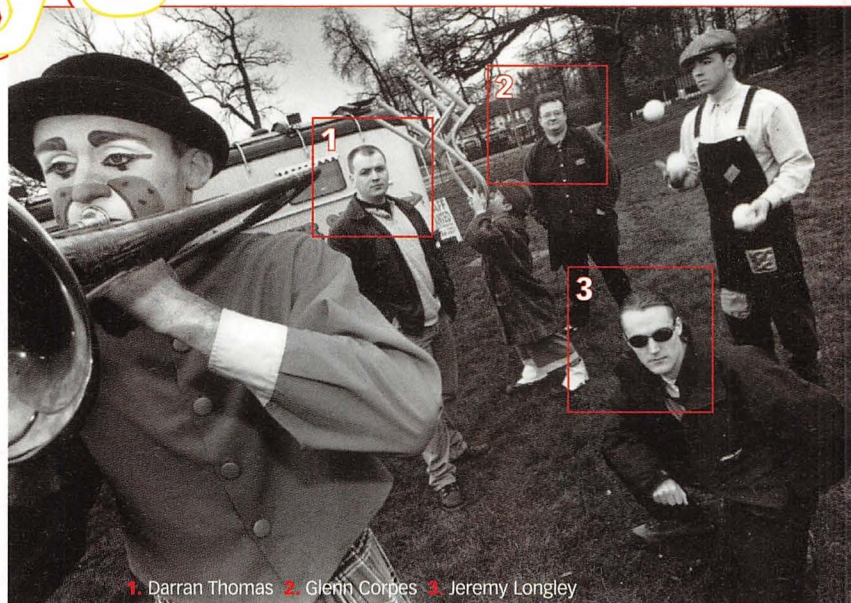

1 Darran Thomas 2 Glenn Corpes 3 Jeremy Longley

you work on whichever groundbreaking pieces of technology you need to actually bring the game up to market speed.

## Fundamental fun

**Edge:** It sounds like you're scaling it down to its fundamental components, ie, the fact that it's enjoyable to play. Does this mean that the lead time is going to be shorter and that the team doesn't need to be as big?

**JL:** That's the idea. There may be games where we'll have this cool concept, but it does need a really solid 3D engine to pull it off, and obviously that's going to push your time.

**GC:** Some start-up companies have had to get in so many people just to get the first game out of the door. In a way, this is an experiment to see if this approach can work. We're pretty sure it can.

**Edge:** So you're saying you can get a game out between the three of you?

**GC:** No, no. [Laughter]

**JL:** It's hard to put a figure on it, and such a figure would only be wrong, but you should be able to get the core aspect of any game with between half-a-dozen and ten people. If you've got extra-special things that you need to make the game look great, then that's cool. If you want to do *Final Fantasy VII* and have over 100 artists working on it, just to give it depth and to expand the game, that's cool as well. But it doesn't take 150 people to get the core content of what the game is, and once you've got that core content you can make that judgment on how much more you need to do to bring the game to fruition.

**Edge:** In terms of fleshing out the games you're working on, have you got a longterm goal for staff count?

**GC:** I think we'd like to keep the company under 20 people for a while, and it won't be as many as 20 for a long time – we'll be lucky to be ten-strong after a year. I'm sure this can still work – stuff like *Quake II* was done by a team of 15, including management, but without using that as a reference, the games in production at Bullfrog at the moment always have at least 20 people before the end of the project. We did *Magic Carpet* with about six or seven in total, and we did *Populous* with two. Sure, that was back then, but there's no really compelling reason for teams to get that big. When a team gets to 15 programmers, probably five of them aren't going to be programming any more, they're just making sure that people are able to work together. And you'd probably find that a team of 15 programmers doesn't really do much more, at the end of the day, than a team of five programmers who actually care about what they're doing. Maybe we're being slightly idealistic, but we're pretty sure we can make it work. In fact, we can definitely make it work this way for our first game or two.

**Edge:** But surely the advancement of technology necessitates bigger teams. The NGPS specs suddenly present enormous scope for massive technological undertakings...

**JL:** At first glance, the specs make it look like you can do many more things, but does that mean that you have to fill the DVD up?

## Core elements

**Edge:** It's not really about the storage medium, though, is it? It's more a question of what the core hardware can do.

**JL:** But doesn't that make development easier?

**DT:** From an art perspective it definitely makes it easier, because currently you've got to be a lot more disciplined with the PlayStation and even PC, with the way you handle textures, etc.

**GC:** You probably won't even count the polygons as you model.

**JL:** We're not trying to be machismo about being a small company; there's nothing macho in writing a game with three or four people – I mean we'll do what it takes – but the smaller the team is, the more involved each member is, and if you can keep it smaller, everyone can focus. If you turn up with an idea one day, you've got the flexibility then to spend a couple of months trying it out, to see if it fits in with the game.

**GC:** Also, Darran was lead artist on a team of 12 on *Theme Park 2*, so we'll probably have a team with more artists than programmers pretty quickly, and there's a lot of stuff in *Populous* and *Magic Carpet* which looks like artwork, but was actually generated by code. The landscape in *Magic Carpet*, for example, was just a few hundred lines of code, and it looked like months of work for an artist in *3D Studio*.

limitations of the PlayStation, and if there's any truth in the claim that programming on the PC makes you lazy, then we're trying to avoid that anyway. I mean, what you can do on the PlayStation – if you've got a fun, tight gameplay concept that's going to work – then you can do that on the PlayStation, on the PC, on Dreamcast and PlayStation 2. If it's a good gameplay concept you can look to expand it for whatever technology you've got available. It's pretty much the philosophy we're using for our first game. We'll do the PlayStation version, and the PC version, and see what happens after that. The fun element doesn't change from console to console.

mean that I can't design games, and that's why we're here.

**DT:** That's another problem with bigger dev teams. Because they want a production-line thing you start to get pigeonholed in your skill; if you're really good at engines, or 3D characters, for example, you tend to get pigeonholed. Now we three like to be involved in a bit of everything from start to finish.

**GC:** Peter [Molyneux] is a great game designer, but he does it as a programmer and not as some guy who sits there with a piece of paper and lets the brains of the team go off and do the work for him.

**Edge:** Overlap is a good thing from your perspective, then.

**JL:** Absolutely – then you understand each other. There's nothing worse than saying, 'Well, Darran, look at this great bit of coding I've done, now all you have to do is build some meshes for it,' because he's going to go, 'Huh?' That's not going to work. You have to understand everyone else's role.

**GC:** There is quite an overlap. Darran and I keep quiet about it, but he's quite technical for an artist. He knows how to program in BASIC. [Laughter] And I was an artist myself, I did the graphics on *Populous*. I was a programmer before, but I got a job as an artist and then moved back to programming later. Jez is a musician as well, so if you could get away with smaller projects requiring only three people, then we'd probably be the three guys to do it.

The interesting thing about Jez is that you need somebody who writes the game stuff, which isn't so much about 'How do I do this?', it's more of a 'What do we do?' It's much simpler code, it's more about structure and it's easy to maintain, although it's not technically difficult to write the AI (which I think is a misused term – AI seems to mean anything that isn't the graphics engine or the sound) – it's actually very simple. And you need the kind of programmer who can focus on that and get a kick out of it. Most of the programmers who I've got a lot of respect for are techy 3D heads, and a team of techy 3D heads

can't write a game. You only have to look at Scavenger with *Into the Shadows*. That was all written in pure assembly code, and they suddenly realised that they had to write a game at some stage. This is a problem that some teams fall into.

**Edge:** If you aren't going to take on the likes of *Half-Life* and *Quake III: Arena*, for example, what sort of games are you going up against?

**DT:** Well, that's part of the point. We don't want to simply 'do a *Half-Life*', because you're just taking their idea and improving on it.

**GC:** We don't need NURB-rendering engines to prove a concept. If we had no better ideas than simply doing *Quake*-with-a-story, or whatever, then we wouldn't be talking about this, because we'd be saying, 'Shit, we've got to make sure we have five passes of textures and the best navigation AI ever seen in a game'. But our ideas have very few dependencies on technology, they're more dependent on 'Try it, see if it works'.



**"IT'S EASIER TO BE ORIGINAL THAN IT IS TO BE THE BEST IN ONE AREA. WE BELIEVE THAT THE DIFFERENTIATION IS AS IMPORTANT AS ORIGINALITY AND MORE IMPORTANT THAN PROVING TECHNICAL ABILITY"**

GLENN CORPES

That's another thing I'd like to focus on, which is something I did in the early days of Bullfrog. With *Magic Carpet* we had a fairly primitive fractal landscape generator, with a slightly sneaky routine for sorting textures, but we can take that further. The last thing I did for Bullfrog – I don't know whether or not they'll do anything with it – is a system that did quadratic curves with lumps. I mean, we won't be using this in the first couple of games, but that's pretty interesting because it was generated by code. The only artwork was a bunch of bump maps, and everything else was done with code. There's cool stuff you can do with code, and it will also make your stuff look different from everybody else's.

**Edge:** What do you think about accusations levelled at PC programmers suggesting that the format encourages laziness?

**GC:** That sort of thing comes from conversion programmers, because they manage to squeeze a 16Mb PC game into a 2Mb PlayStation. It is laziness, and it's a problem with having big teams. I don't think the PC encourages laziness, it's just that you have base PCs now with 16Mb, possibly 32, so that becomes the development standard. I think the term 'laziness' is a bit unfair.

**JL:** There's still a strong PlayStation market, and there will be for some time to come – PS2 isn't going to hit until late next year sometime. We're still very aware of the

## Design for life

**Edge:** You're programmers and an artist by trade, but you're talking like designers. Why haven't you got a designer on board?

**GC:** We are all designers.

**JL:** That's the point about having a small company, really. If you're in the games industry, you can either take a completely sort of professional 'I'm paid to do this' role, where you do your nine to five and go home. That's not me, and I don't think that's these guys either. I've been playing games and programming computers for 15 years. I've always wanted to write games – writing games means creating games. Now I program, that's the skill that I have, but that doesn't



**"IF YOU'RE IN THE GAMES INDUSTRY, YOU CAN TAKE A PROFESSIONAL ROLE, WHERE YOU DO YOUR NINE TO FIVE AND GO HOME. BUT THAT'S NOT ME, AND I DON'T THINK THAT'S THESE GUYS EITHER" JEREMY LONGLEY**

**Natural selection**

**Edge:** So without a bunch of suits upstairs telling you what they perceive will and won't work, how do you decide which ones to proceed with?

**JL:** The thing is, if you follow this philosophy it doesn't take long to come up with an expression of an idea, which you can see and play. If you get enough people together that play games with you, who understand what games can become and that can appreciate an idea without having to see all the flash trimmings that go with games nowadays – and that might only be three or four people – you should be able to see this at that point. If you can't see the game idea after a month, then it's probably not worth doing. Unless you're taking another angle, which is to make all the technology and the game will follow, but that's not what we're going to do. With a prototype of a game, if it's not demonstrably fun, then we're not interested.

**Edge:** Surely, as soon as you sign to a publisher, you're immediately bringing the suits back into the equation.

**JL:** You are, but what you have is enough of a core game concept, that we all agree with, and that's what we have to pitch – it's this game we believe in. And if people don't like it, then we go to someone else. We come up with a game that we want to do, and we find a way to do it.

**GC:** We have enough confidence in the game ideas to hopefully get a publisher and give the impression that they're not going to be able to change stuff, and I don't think publishers do that with external development as much as they do with internal, unless a

Bullfrog a few years ago because there were some original game ideas that were canned or cancelled because marketing people didn't think they could sell them. There were certain people who were so idealistic about this that they didn't want to work on projects where marketing could come in and veto them.

I think that's being over-idealistic, though, because there's no reason why you can't be original and also be sellable in the same way as a story and technology-driven game. Just because the idea is original doesn't mean it's some weird niche thing. Why shouldn't there be originality in fully marketed real games? I guess the only reason really is if the publisher wouldn't want to take the risk, but we're the ones taking the risk.

wouldn't look at that and say, 'Well, this is actually different to the rest, it's not just environment mapping on the cars that do slightly more realistic skids that makes it even harder to play'. I don't think we're going to do a driving game, at least not in the first two games, but we're not talking about totally alien, abstract concepts here, we're just talking about things that are based around an original idea. We'll do a driving game if we can think of an angle that makes it worth it.

**JL:** Trying to beat *Gran Turismo* isn't the angle we're looking for. The whole games industry is about fantasy in many ways. I remember growing up, reading articles in *Amstrad Action* and thinking, 'Wow, that's amazing, look at what this game lets you do', and then you get the game and generally you're disappointed. Every now and again you really get into it – *System Shock* was a great game: you went along, you got in there, and you almost neglected the fact that the 3D engine was beginning to look a bit dated because you could get into it, you could really play the game, and... Sorry, I've gone into rant mode.



team has been commissioned to write something a publisher wants. Maybe I'm harking back to the old days, but there was very little involvement from EA at Bullfrog or from any of the external producers at EA. In fact, there never has been much involvement from EA at Bullfrog, it's more to do with the way that Bullfrog has changed internally. And the company's changed for the better in a lot of ways because it can make hugely ambitious, really polished projects like *Theme Park 2* and *Dungeon Keeper 2* possible.

**Edge:** Because of your background, are you consciously moving away from the perceived Bullfrog style of product, ie, god games?

**JL:** It's really just a case of releasing shackles. Bullfrog was good at god-style games, but we're a new company, so we can do whatever games we think are the best. If we wanted to do a god game, we'd do a god game.

**Edge:** Do you want to do a god game?

**GC:** To be honest, the first game is not the kind of game you'd expect from Bullfrog. The second, possibly, is more Bullfrog-esque, although there's no concerted effort to do this.

**Edge:** It's not *Flood 2*, is it? [Laughter]

**GC:** We're trying to focus on original fun, core gameplay mechanics, and it seems to be that a lot of this industry is confusing groundbreaking technology and a cool storyline with originality. If you look at the kind of risks that were taken in developing games on the 8bit and 16bit formats, they were a lot more original. It was like, 'Shit, I'm doing this suddenly weird thing that no one's ever done in a game before', and, okay, some of their ideas were more subtle in those days. Okay, sometimes they were crap, but some were the coolest games ever.

**Edge:** The keywords you're using are "fun," "gameplay" and "originality," but those three things can't be communicated from the back of a box, which is how so many purchases are made now that gaming is a mass market entertainment concern.

**GC:** That's an interesting point, actually, because there was a spate of people leaving

**Driving forces**

**Edge:** The problem you have, of course, is that mainstream consumers buy driving games, in the same way that they buy cornflakes because they like cornflakes. Communicating to them and saying 'Here's something you haven't tried before' isn't easy.

**JL:** [Agitated] But if you take that line aren't you condemning the gaming industry to a life of mediocrity?

**Edge:** A good example would be *Half-Life*, which is 'Quake II with a story', as you termed it. In some respects it could sell itself on visuals alone, despite its other merits.

**GC:** Just because a game's based on an original mechanic doesn't mean that it's an alienating concept to the mainstream. There's no reason why we wouldn't do a driving game, for example. One of the ideas we were throwing around was a driving game, but it was based around a different mechanic. There's no reason why somebody into other driving games

**Edge:** What are you going to miss most about working at Bullfrog?

**GC:** Share options. [Laughter]

**JL:** No, no, no.

**GC:** The honest answer to that is playing multiplayer *Quake* over the network. For the last year or so we've been playing *Quake I*, solidly, on one level, about six of us. Two hours a night, every weekday...

**JL:** No, we'd been there a long time, we'd made a lot of friends, and we still keep in touch with them, but the camaraderie of a games company is as vitally important as any other aspect. We're all good mates, we drink together, and you have to have an understanding of the people you're working with in order to produce a game. As I say, unless you're going to treat it like an accountancy model, a business model – this guys does this bit, this guy does that bit, this guy does the other bit – you have to have a certain amount of flexibility. It's like being in a band in many ways. I've been in many bands over the years and you get to the point where you just know what the other guys are doing.

You don't have to think about it, you don't have to plan or schedule things. When you get to know each other you just make things happen – you get on with each other, you don't have to make a formal proposal, write it down, email it to someone for their approval, get them to send it back – you just get on and do it.

**Edge: In two years' time, what do you think you will have achieved?**

**GC:** We'll hopefully be finishing our second game. The timescale for the second game is impossible to state because it depends on how quickly we can staff up and get it in parallel production with the first game.

## People business

**Edge: How are you going to find more good people? Is it a known-contacts issue or a matter of advertising?**

**GC:** For us, it'll be both, but people have different opinions on this. If you talk to Mucky Foot, for example, the original three guys claim that they all used to live in the same house, and that when they first moved in together, a good couple of years before they left Bullfrog, they were planning it then. Their way of building a team was initially based on association.

**Edge: Glenn, you've been working on games for years – how do you keep motivated? Does technology drive you?**

**GC:** I'm fairly technology-driven, I suppose. Basically, what happens is that ideas build up that you want to try out and that's one of the reasons I left Bullfrog, because when you're

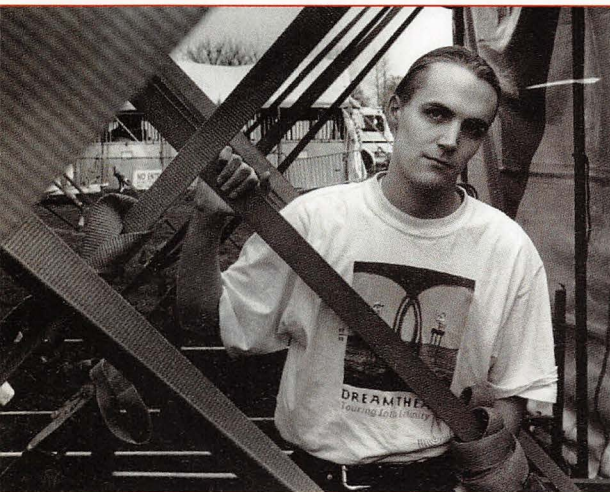

## "THAT'S ANOTHER PROBLEM WITH BIGGER DEV TEAMS – YOU GET PIGEONHOLED IN YOUR SKILL. NOW WE LIKE TO BE INVOLVED IN A BIT OF EVERYTHING" DARRAN THOMAS

managing a project, or managing the R&D department, it's very hard to get programming done. So I've got loads of ideas that I want to try out, some of them graphical, some of them based on other elements of gameplay. In fact, our second game is based on two or three ideas that I really want to just sit down and try out. And the ideas are queuing up, so I get more motivation out of trying these things out. It's just nice to be back doing the stuff rather than sitting in meetings all day.

**JL:** It's a freedom thing. As I said, I've always had ideas I've wanted to put into practice. That's the way it should be – if you have an idea you should be able to try it there and then, or if that's not appropriate then next week, but you don't want to have to wait. Not every idea you have is going to work, but you have to have the opportunity to try ideas out until you hit upon the one that's as good in execution as it was in your head.

**Edge: How are you differentiating yourself from other break-off teams?**

**GC:** I think we're focused differently. I think most break-aways seem to be either technically driven or proving themselves with their first games to their publishers, which means they're

taking on really stupid competition head-on, which is not what we're going to do. Maybe I'm being naive here, but you can only guess how other people are thinking when you see their first game come out, and I think our approach is different. But I can't be sure. I've been involved in projects that were very original – I'm not saying I was behind all those things, but I was involved in a lot of them and I know where ideas came from, historically, and I've seen what worked and what didn't work. Ever since *Populous* was a success, after that game we had a very unofficial postmortem – why did it work, etc – and even back then we were arguing about what was cool about it and what wasn't, and I provided theories about what worked and what didn't. And this company's mine as much as it is any of ours, and I

want to see those ideas driven into things to try out for ourselves.

**Edge: If there are seven different types of story, is there a finite number of game genres?**

**GC:** As I said, we're not going to claim we're inventing genres here, but we are tackling things in a different way. If anyone wants to say we are inventing new genres, possibly somebody might look at what we're doing and say it's different enough to really stand a mile apart from anything else, but we're not going to say we're creating something as different as *Populous* was in its day.

**DT:** If you call mixing genres creating a new genre, then that's more like what we're doing.

**GC:** Well, 'mixing' is perhaps the wrong term. Over the years people have tried to mix stuff and it just hasn't worked. We did it ourselves years ago, trying to mix a puzzle game with a shoot 'em up and the result was *Fusion*, which failed. So we're not talking about mixing stuff, we're talking about picking up an idea and running with it.



# Gallery

*The art of the videogame*





Infogrames is determined to pull ahead of its driving-game rivals with this, the rich-in-potential *V-Rally 2*, which provides challenging terrain over 92 tracks in 12 international locations. To achieve the highly realistic look of the Peugeot 206 World Rally Series car in this render, the image contains more than a million polygons, 100Mb of textures, and was rendered up to 6,000x6,000 pixels.

Image rendered by **DigiMania Limited**, a member of Digital Animations Group plc, using *Lightwave 3D*



The starkly futuristic world of Eidos' *Omikron*, previewed this issue (see p36), features dark, intensely atmospheric exteriors and interiors such as those shown on this page. Between 50 and 100 motion-captured characters are included in the neon-lit street scene, while *Lightwave 3D*'s Steamer and Puppet Master features were used to enhance the smoky stripclub locale and gyrating dancers.

Images rendered by **DigiMania Limited**, a member of Digital Animations Group plc, using *Lightwave 3D*



## SILENT SCOPE

KONAMI DROPS THE BEAT AND AIMS FOR A DIFFERENT TARGET

Developer: Konami

Release: TBA

Origin: Japan



The skilled sniper needs to be able to shoot accurately in different situations. The Hotel Imperial is a time attack mode (above). A shooting range for training is also included (left)



It's not just 'vicious criminals' that will find themselves in the cross-hairs of your gun. Fast jet pilots who work for evil terrorist groups are fair game, too

It was only going to be a matter of time before the general gaming trend for realism infiltrated the arcade. The closest the cartoonish coin-op world has got to the concept, however, has been specialised cabinets such as the one for *Get Bass*. Still, after its work on rhythm-based controllers, Konami's R&D labs must have been shocked to receive the brief for *Silent Scope*. 'You become a sniper to shoot vicious criminals,' is the official explanation. Based on a full-size assault rifle with a telescopic sight mounted on top, *Silent Scope's* gun is a fearsomely realistic controller.

The rifle is integral to the gameplay, though. A magnified version of the action on the external screen is displayed on the small monitor inside the scope. Scanning for hostile elements, you have to be quick and accurate when shooting. *LA Machineguns* this isn't – ammunition is limited and enemies will shoot back. Health levels can be recovered by shooting the medikits that appear throughout the game.

Each of the stages takes place in a number of different environments. One of the more advanced involves firing from a helicopter in true SWAT team style. During night levels, players are provided with an infra-red scope. Targets can be identified by the heat from their cigarette tips.

Three modes are offered: training, time attack and story. In the training mode, players simply have to shoot criminals while avoiding civilians. The time attack stage relies on the speed of acquiring and hitting targets. One of these levels requires players to shoot three targets who appear at any one of 40 hotel windows. The story mode sees the player protecting a presidential convoy from terrorist attack. Hostages also have to be protected and rescued. This mode generates multiple endings, each with different bosses, such as helicopters and aircraft, to overcome.

Having quietly demonstrated the game in London, the US and Japan, Konami has already received excellent feedback. Its public awaits...



The cabinet features a full-scale rifle with a magnifying sniper scope



# METAL SLUG X

SNK RELIES ON THE ENDURING CHARM OF 2D SHOOTING

Developer: SNK

Release: TBA

Origin: Japan



**Metal Slug X positively revels in its enormous, mechanical bosses, providing fast and furious gameplay to keep you on your toes**

**P**roving that technology isn't the only factor that drives games forward, SNK continues to develop new versions of its 2D shooter *Metal Slug* series. While Neo Geo Pocket Color owners look forward to *Metal Slug: First Contact*, arcade-goers are preparing for *Metal Slug X*.

Compared to *Metal Slug 2*, however, little has fundamentally changed. New characters can be selected, but remain split between two male and two female options. One of the few things to have been expanded are the item-based elements. Weapon power-ups work on two levels, with the most powerful options being the Big-Shot items. Ammunition and supplies for the *Metal Slug* vehicles are also scattered around the levels, while beneficial food items are another addition. Curiously, for such an unrealistic game, over-eating will cause characters to get fat and move more slowly.



**Power-ups are fundamental to gameplay with Big Shot weapons being the most powerful**

The basic control system has changed little, however. A is used to shoot, B to jump and C to throw grenades, while a combination of A and B will launch the eponymous Metal Slug.

But while it may not demonstrate a great deal of improvements, this *Metal Slug* iteration suggests that there's still a good deal of mileage left in this cult series.



# GIGAWING

CAPCOM TAKES ITS 2D TRADITIONALISM ELSEWHERE

Developer: Capcom

Release: TBA

Origin: Japan



**I**ntroduced at February's AOU, *GigaWing* marks an unexpected return to the land of 2D vertical shoot 'em ups for Capcom.

While perhaps somewhat classical in nature, the overall graphical quality is hardly revolutionary. There are new features, however, mostly in the form of the game's Reflect Force system, which enables you to send enemy fire back the way it



**GigaWing's Reflect Force feature is a novel addition, enabling you to return enemy fire**

came, albeit at an increased magnitude, with the potential benefit of rapidly clearing a large section of the screen. The system works on a build-up principle, similar to the super special moves from the company's beat 'em up offerings: a gauge gradually fills up according to the amount of continuous fire button pressing and when full you can unleash all the Reflect Force you can muster (for a limited period of time, naturally).

Six stages are offered, all heavily based on the characters in the game. Should you clear all six without necessitating continues, a seventh level becomes available. The whole thing should last for a reasonably cost-effective 45 minutes.

Intriguingly, rather than targeting the hardcore 2D shoot 'em up market, Capcom seems intent on focusing on the casual arcade player, a fact probably best illustrated by *GigaWing's* pretty visuals and the accessibility of its simplistic gameplay. It could prove a favourable combination.

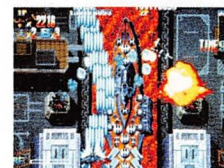

**The pretty graphics are intended to attract the casual, rather than hardcore arcade crowd**

# ALIENS

One of the regrettably few movie licences in videogaming history that actually does its celluloid counterpart justice, Electric Dreams' title is a hugely compelling voyage into suspense, terror, relentless panic and the occasional acid bath



Due to the base's numerous rooms, Electric Dreams' game was packaged with a helpful map. The Spectrum version offered better resolution than the C64 version here shown

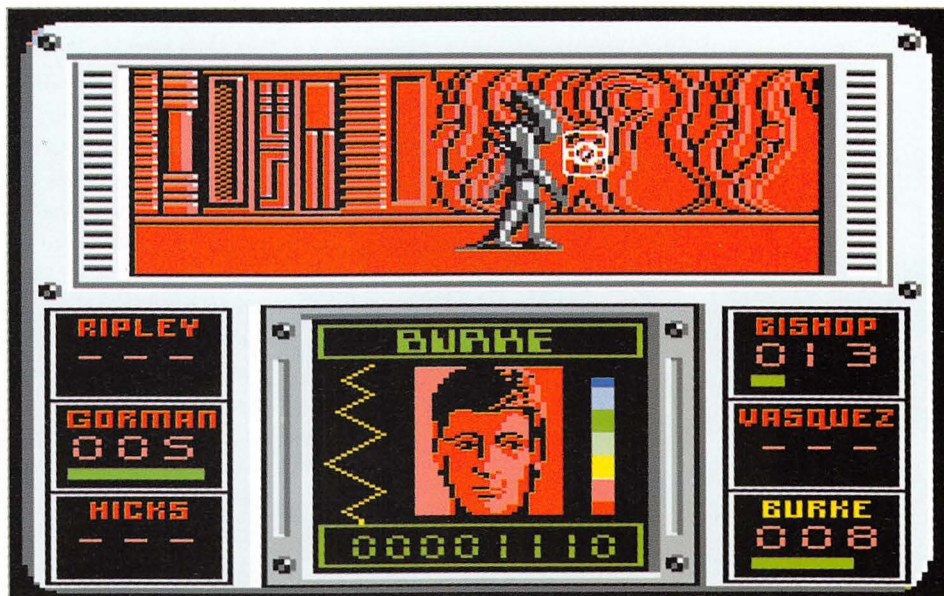

Oddly – and perhaps sadly – Electric Dreams' *Aliens* has been long forgotten. Based on James Cameron's action sequel to Ridley Scott's 1979 sci-fi horror classic, *Aliens* is perhaps one of the most successful movie licences to make the transition to computers. Not necessarily in turnover terms, of course, but in the way the game manages to capture the sense of panic and urgency conveyed in the film.

Naturally, then, you'd expect the plot to remain fairly faithful to its cinematic counterpart: in charge of a sextuplet of colonial marines (Ripley, Bishop, Hicks, Vasquez, Gorman and Burke), your task is to infiltrate the colonists' base (foolishly built on the alien-infested planet of the first film) and look for any survivors that may have somehow escaped the near-inevitable face-hugging/chest-bursting experience.

Controls are relatively simple – either move the cursor over a door and press the space bar to move through it, or instruct a marine to move a number of rooms (one to nine) north, east, south or west while you control one of their colleagues. The top half of the screen

displays the room (in firstperson and 360-degree scrolling) while the rest of the screen informs you of the status of each of your marines (health and ammunition levels). Taking control of just one marine at a time – a simple key press swaps between them – means it's vital to keep an eye on the health bars, whose various colour alterations relay conditions, for example, blue indicates the presence of an alien in the same room and action is advisable unless you're happy to let the impregnating process begin (bar turns yellow). Should this happen, you can still save your marine by quickly directing another one to the same room for some target practice. However, as with all firstperson alien encounters, miss and be prepared for a screen full of static.

By today's standards, the graphics look scarily simplistic, yet the remarkable sense of involvement endures as you scatter your marines throughout the base, only to attempt a desperate retreat after aliens have rapidly reduced your unit to a cosier – and panic stricken – trio. The resulting unnerving experience remains rarely equalled even by today's videogames.



# EDGE VIEW

The videogames world never stands still, riding the breaking wave of advancing technology. In this regular column **Edge** puts the industry's progress in perspective with a look at yesteryear's headlines: five years ago this month

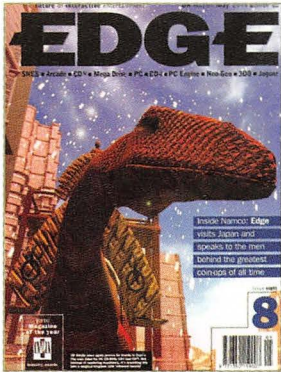

Edge issue eight, May 1994



*Aliens Vs Predator* was a 'high point' for the ill-fated Jaguar, running in 65,000 colours

**C**onfusion surrounds Sega's next generation hardware as news of Mars, the Mega Drive enhancement that is to become 32X, filters through. Thirty titles are said to be in development, although where they're coming from isn't clear...

Following **E7**'s early shots of Sega's *Daytona USA*, the completed game 'shines' at 1994's AOU. 'Initial reaction was that it's better than *Ridge Racer*,' gasps one caption. And first impressions prove correct as the AM2 racer swiftly gathers a massive international following.

Eerily forshadowing the spring '99 shipment of NGPS development kits, May '94 was the date that Sony delivered its first PlayStation tools, with Capcom and Konami among the premier recipients. NEC is running scared, as rumours that it's considering abandoning its next console, codenamed Tetsujin (Iron Man), abound.

With *Ridge Racer* still the talk of the town, **Edge** invades Namco's Tokyo HQs to unravel the company's secrets. **Youichi Haraguchi**, a general manager in the consumer division, confidently claims that, "We think we can make a 100 per cent translation of *Ridge Racer* to the PS-X." It wasn't '100 per cent', of course, but it set one hell of a precedent. **E**



Concern over the abilities of Commodore's CD32 (top) hardly seems relevant today. *Daytona* at AOU '94 (left) and Shigeru Miyamoto (right)

### Did they really say that?

"We'd like Atari to succeed primarily because we're looking for a replacement format." Then-Ocean development director **Gary Bracey** on supporting the ill-fated Jaguar

### Did Edge really say that?

"Unlike *Doom*, *Aliens Vs Predator* is more than just an attractive 3D shoot 'em up,' previewing Rebellion's first attempt at the *AVP* license

### Testscreens (and ratings)

*John Madden NFL '94 Football* (3DO; 9/10), *Ultimate Tiger* (FM Towns Marty; 8/10), *Tempest 2000* (Jaguar; 9/10), *Virtua Racing* (Mega Drive; 8/10)

# PIXEL PERFECT

Every gamer has occasional moments of sparkling excitement, be it the first time *Speedball* booted up, or completing *Sabrewulf*. High-profile gamers are no exception. Core Design's **Gavin Rummery** remembers a game that 'had it all'

**S**o there I was, playing *Hired Guns* on my Amiga – the best game I had ever played. I was raving about it to my friend, when he looked dubiously at the screen and went, 'Uh-huh, I'm playing a cool game at the moment, too, come and have a look.' So he booted up his clunky old PC and showed me *Ultima Underworld*. I stood there with my mouth hanging open – I just couldn't believe what I was seeing: a fully texture-mapped 3D environment moving in realtime, the first I'd ever seen. It had it all – a huge detailed plot, loads of sub-quests and puzzles, a massive and intricate dungeon to explore, sword fighting, magic and bags of atmosphere. It was truly great, and I thought, 'This is the future of gaming; this is virtual reality,' and dreamt of the kind of games that I expected to follow. Unfortunately, a bunch of Texans had other ideas, and took over the world with a game called *Doom* – it was like *Ultima Underworld*, but stripped bare of everything but the fancy 3D and action bits. And that was what everyone else copied... **E**

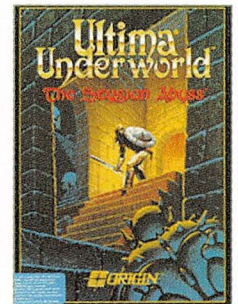
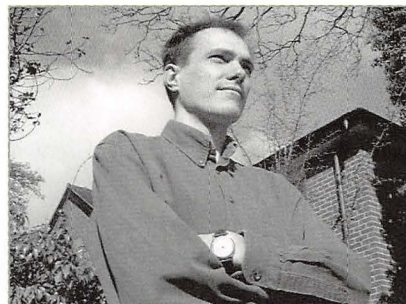

Lead programmer **Gavin Rummery**, who worked on both the original *Tomb Raider* and *Tomb Raider II*, found inspiration in *Ultima Underworld*



## Kenwood DVF-9010 DVD Player

Contact: 01923 816444

Reviewing DVD players is getting harder month by month. When the first machines arrived, after scratchy old VHS the promise of perfect sound and vision was almost too much to bear. Now, not even a year on, familiarity is breeding contempt, and it's becoming increasingly difficult to differentiate between the different players – particularly considering that most of them have the same engines running inside, regardless of the logo on the front.

Hurrah, then, for Kenwood's latest player, which will shake even the most jaded DVD follower out of slumber. The fantastic built-in surround-

sound decoder transforms any Pro-Logic Amp into a Dolby Digital unit and a couple of Virtual Surround Sound formats create 3D effects without requiring you to fork out for a host of speakers. Thankfully, picture quality is also free from artifacts, although you'll probably spend more time gazing at the plainly gorgeous casing. Displaying slightly more curves than Kelly Brook, and a well-thought out panel that slides up and down to reveal the disc tray, the DVF-9010 is a victory of design. Only the over-inflated price tag of approximately £1,000 lets it down.



## Schneider Manhattan 2000

\*£899 approx. Contact: 0161 374 0101

You may never have heard of the company before, but German-based Schneider is determined that the Manhattan 2000 system will help it break into the UK market. A magnificent piece of kit, the main 110cm-tall unit – all brushed metal and wood – houses the CD player, cassette deck, amp and tuner while leaving plenty of room for a subwoofer. Two lanky satellite speakers complete the set, which, when combined with the sub, thump out a remarkably good soundstage, ideal for today's big-beat music and the like, although classical lovers may find their favourite symphonies sounding a tad tinny.

A breeze to install, you simply need to connect the speakers and plug the thing in. The system also has inputs for phono, MiniDisc and RDS to automatically tune in up to 30 FM stations. Other bonuses include a timer for recording radio shows, one of the most comprehensive remotes you'll ever see (pictured), and the joy of smugly watching your friends' jaws hit the floor when they first lay eyes on your skyscraper-esque new hi-fi.





## Leowe Spheros 42-inch Plasma TV

\*£13,500 Contact: 0500 888909

Yet another telly has arrived on the market, ready and willing to snap your spine as you attempt to lug it out of the box. Make no mistake, however, the Leowe Spheros 42-inch Widescreen Plasma TV is a wieldy beast, but when installed it will genuinely bring forth gasps of amazement from anyone wandering into your living room.

Consisting of the exquisitely crafted silver screen itself, a motorised stand, the master unit that includes the necessary tuner and connectors for DVD player and satellite, and a pair of active speakers, the skinny Spheros certainly delivers the pics. Colours are rich and vivid while, thanks to the wonders of progressive scan, the amount of detail on display is staggering.

Unfortunately, the sound doesn't live up to the imagery, the speakers merely being adequate additions rather than the excellence you'd expect at this price point, and the absence of Dolby Digital is, frankly, unforgivable. The mass of fiddly little wires that need to be connected before the damn thing works is also disappointing, especially as they come with no real instructions or colour coding. Leowe can't be forgiven for cutting corners like this.



## Nokia 9110 Communicator

\*£350 (with connection) Contact: 01480 434343

Far less clunky than its brick-like predecessor, the new Nokia 9110 Communicator means that for the first time you really needn't be out of touch ever again. Setting up is simply a case of slapping in your Sim card and entering your Internet provider's details, and before you know it you can be checking your emails, faxing your colleagues and surfing the Web from wherever you find yourself.

As if this wasn't enough, there are simple action games, spreadsheets and programs for composing your own ring tones, so you can annoy fellow commuters to your heart's content.

There are niggles, though. The mono screen is fine for writing emails or keeping the personal organiser up-to-date, but trawling through graphic-laden Web pages can be a painfully slow pastime. Also, you'd think that Nokia might have included satellite connectivity for using the phone around the globe. Maybe next time.





## And it's goodbye from Tokyo

**Japan:** It's a long-standing tradition at Japanese exhibitions for the ranks of female hired hands simply not to pack up and sidle off at the end of

each day, but to form orderly lines and bid farewell to visitors. The spring Tokyo Game Show presented some ideal photo opportunities, then...



Sega had so many girls (in Dreamcast colours, natch) that **Edge's** lensman couldn't fit them all in one frame



Photography: Hiroki Izumi

## Dressing to kill

**Japan:** A trip to Japan for the avid gamehead isn't complete without a jaunt over to Tokyo's Akihabara district (aka Electric Town), and **Edge** recently took a break from Tokyo Game Show duties to check out its favourite game outlets. Game merchandise always ranks highly on the list of desirables in Akihabara, and the newest wave to hit the shops didn't disappoint. Along with fairly obvious items such as cute clocks fashioned in the image of game characters, though, **Edge** discovered some rather more intriguing items – most bizarrely, perhaps, the full-size replica *Final Fantasy VIII* outfits. Yes, for the princely sum of ¥88,000 (approx. £460) each, you and a ladyfriend can walk down the street convincingly fitted out as Squall Leonheart and Riona Heartily. Shockingly, for what on the face of it seem like niche items, both outfits had sold out at the time of **Edge's** visit. You can bet Lara's clothing range wasn't this popular.

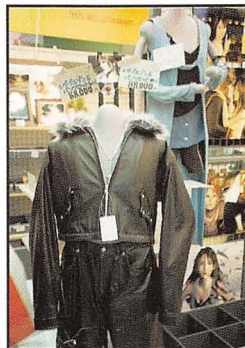

Clockwise from right: Beat 'em up towelling bags; *FFVIII* costumes; slick *FFVIII* models; clocks with character







## Controller freaks

**Japan:** The success of games such as *Final Furlong*, *Get Bass!* and *Rapid River* is proof that arcade-goers hunger for something more than simple joystick-and-keys combinations nowadays, and coin-op manufacturers have recently gone into overdrive in pandering to their whims. February's AOU show in Tokyo revealed the latest examples, the most innovative being Taito's *RC de Go!*, a model car-racing sim whose

controller apes the real thing perfectly. Other notables included Namco's *Angler King* (complete with effects driven by air-compressor), Konami's *Guitar Freaks* (with an electronic axe featuring three buttons in place of frets, and a flickable rocker-switch you 'strum'), and Sega's *Balance Try*, whose gameplay simply could not exist without a custom surfboard-esque controller. So don't hold your breath for a Dreamcast conversion.



Photography: Hiroaki Izumi



Controller highlights at AOU: Taito's *RC de Go!* (above); Sega's *Balance Try*; *Motion Trial Project* (top left); Konami's *Guitar Freaks* (left)

## A sticker kit too far

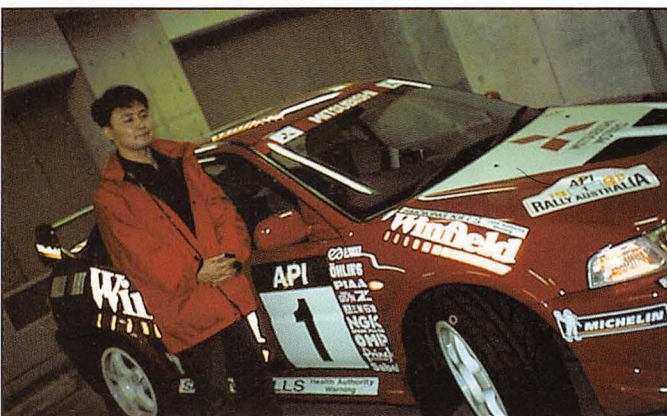

*Gran Turismo* creator Kazunori Yamauchi drives a rather distinctive car to the office

**Japan:** You may recall Polyphony Digital Inc. executive vice president and *Gran Turismo* creator Kazunori Yamauchi excitedly telling *Edge* about a set of car decals he'd bought in an online auction in *E68*'s *GT2* world exclusive prescreen. The decal set was taken from current World Rally Champion Tommi Mäkinen's car after he'd finished thrashing it in last year's Australia Rally. Well, on a recent trip to Tokyo, *Edge* revisited Polyphony's offices and met up with Yamauchi-san, who proudly showed off the new livery of his blood-red Lancer Evolution V. Tokyo's main Mitsubishi dealer was entrusted with the laborious yet delicate task of applying the decals, and the result is undeniably impressive.

Inside Yamauchi-san's car, rather than empty crisp packets, discarded Mars bar wrappers and a pack of Handy Andies, you'll find a four-point racing harness, a firmly-secured fire extinguisher (a requisite before any car is allowed onto a circuit) and a pair of OMP racing gloves for those weekends spent haring around the local track.

Unhealthy obsession or the dedication of a true professional? The latter seems more likely.





## Bandai victorious in handheld head-to-head

**Japan:** 'I'm not BOY' shout Nipponese adverts for the updated Neo Geo Pocket, now featuring a colour display in place of the original's monochrome screen. Unfortunately for SNK, Tokyo's ad men have hit the nail right on the head – and it's sealing the Pocket's coffin. First weekend sales for the new handheld scraped in at a distinctly un-Game Boy-like 294 units. Despite several promising features, including a Dreamcast link-up facility and a wireless multiplayer system, it seems that Japan's youth simply aren't interested.

Meanwhile, the performance of the WonderSwan – Bandai's foray into the handheld market – is going more smoothly, helped in no small way by a suitably tiny price point and a version of Taito's ludicrously popular *Densha De Go!* (*Let's Go By Train!*). Now you can run your own train on time while sitting in a carriage of the real thing. First week sales of almost 60,000 seem to indicate that Bandai is on to a winner.

Software support for the WonderSwan has come from all quarters of the Japanese videogame industry, including big hitters such as Namco.

Both Sega and Sony are even reported to be interested in Bandai's booming baby, although SNK's Dreamcast cable for the Pocket Color acts as an umbilical connection to Sega. But with Dreamcast currently shipping less than 10,000 units per week (unaided by a slew of second-rate software titles), it could prove a match made in hell. Certainly, if SNK fails to deliver anything more exciting than *King of Fighters Dream Match '99* and sister Pocket title *King of Fighters R2*, then **Edge** can't see anything but stormy waters ahead for SNK's capable little handheld.

Tucked away on the Neo Geo Pocket stand at the Tokyo Game Show was an add-on that elicited excitement from all who spotted it. Piggybacking the console via its cartridge slot, SNK's ingenious wireless multiplayer unit allows up to 64 players to simultaneously play together. The nature of the titles which will support the unit is currently unclear, but strategy-led titles seem more likely than all-out actioners.

Neo Geo Pocket Colors should become officially available in the UK shortly, but the WonderSwan remains unlikely to receive similar support.



SNK's Neo Geo Pocket Dreamcast link was demonstrated with *King of Fighters R2*. Excited yet?



The original mono version is still relatively new, but SNK has already succeeded it with this version

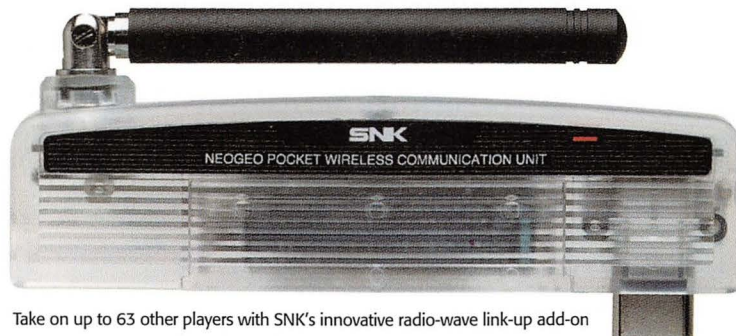

Take on up to 63 other players with SNK's innovative radio-wave link-up add-on



SNK and Bandai went head-to-head at retail. The latter won

## DataStream

Number of redundancies the Sony Corporation will make over the next four years to help 'consolidate its industrial empire': **17,000**

Percentage of Sony overall profits predicted to have been generated by PlayStation: **51%**

Total area taken up by E3 in Los Angeles this year: **525,000 sq ft**

Total number of software titles exhibited at E3 last year: **1,600**

Amount of work required to develop the next generation PlayStation's Emotion Engine CPU: **238 man years**

Cost of new fabrication plant for Sony's Emotion Engine chip, due online March 2000: **\$580m**

Amount of money GT Interactive has earmarked to promote *Driver* in the UK: **£1m**

Winning bid on eBay for an *Ultima Online* character, built up over five years with more than 500,000 gold pieces, rare armour and myriad silver and magical weapons: **\$521**

Number of Dreamcasts Sega predicts it will have sold globally by the time Sony launches its new machine in Japan: **5.5m**

Units of Dreamcast software Sega predicts it will have sold globally by that point: **36.1m**

Percentage increase in profits for Konami in 1998: **89%**

Opening week figure for *Wing Commander* movie in US: **\$5m**

Amount of money 3Dfx is planning to spend on TV, print and Internet advertising to promote its graphics cards: **\$20m**

Percentage of Japanese developers polled by *Famitsu* who felt that the next generation PlayStation wouldn't be as popular as the original unit: **29%**

Percentage of UK working-class families that have a console in the home: **72%**

Percentage of children in UK who have a PC at home: **53%**

Time each day that British children spend in front of TV screens: **5hrs**

Cost of a single ticket for the Millennium Dome: **£20**

Fee to be paid to Neil Diamond for playing a concert on New Year's Eve 1999: **\$9m**

Ticket price for Barbara Streisand concert on the same night in Las Vegas: **£1,250**



## Home improvements

**UK:** With the sales of guitars long outstripped by samplers, the musicians of the future are more likely to fall down the stairs than suffer stage-diving injuries. No surprise, then, that the fight for the bedroom musicians' dollar is warming up thanks to a number of sequel titles. And after working through Hip Hop and Rave variations, the PC-based *eJay* series is returning with *Dance eJay2*.

Unfortunately for the nation's sanity, this is an extremely easy program to use – just click and drop a combination of the 1,300 preloaded samples into place and let rip. Many features have been

updated. You can now record using 16 tracks, each with individual volume control, rather than just the eight of the original. There are plenty of new gadgets to play with, too. A groove generator lets you build drum tracks using ten samples in 1/16-second chunks. The effects studio allows samples to be filtered, echoed and distorted until even the most twisted ears are content. Full-on boffins can also time-stretch samples, varying the standard 140bpm tempo. And if that wasn't enough, publisher Fast Trak has even set up a 12-inch record label to release the results of its little monster. Has it never heard of what happened to Dr Frankenstein?

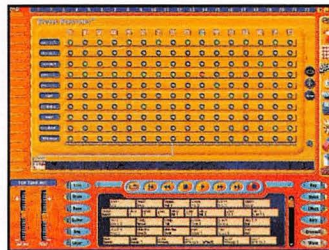
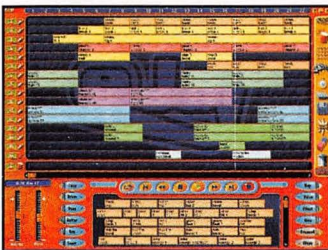
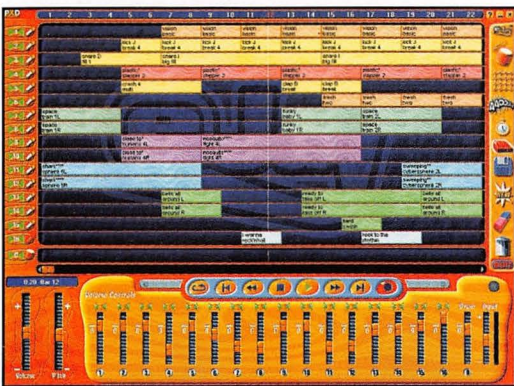

Cashing in on the bedroom DJ bandwagon, making beautiful music is as easy as arranging coloured blocks with the updated *eJay 2*

## Playing for laughs

**USA:** If you're fed up with the half-arsed reporting and persistent bickering that plagues so many game-related sites on the Internet, you may find solace by visiting two concertedly alternative 'news' resources whose take on the world of interactive entertainment is as whacked-out as it is controversial.

The Mushroom ([www.themushroom.com](http://www.themushroom.com)) is a direct homage to renowned satirical site The Onion, and is updated as often as its maintainer can manage (ie, irregularly). Content-wise, it's at its best when it has a pop at targets less obvious than Nintendo and Bill Gates, and its spoof news stories are in many respects better written than those of National Game Review ([www.nationalgame.com](http://www.nationalgame.com)). Both sites really shine, though, when their authors wheel out *Photoshop* in order to doctor imagery with which to illustrate their stories. Morally bankrupt both sites may be, but at least they endeavour to raise a smile.



National Game Review (top) and The Mushroom (above): not yer average Websites

## Something fishy going on

**Japan:** There are always lots of niche titles shown at the Tokyo Game Show, but rarely are they given as much stand space as *Seaman* was at the spring exhibition. The Dreamcast title, featuring, as the title suggests, a fish/man hybrid, was accompanied by 'authentic' curios hand crafted by the creatives behind the project. Least convincing was a fish/man skeleton and a dehydrated research specimen (below), both looking like second-rate *Sunday Sport* hoaxes.



## Virtual insanity

**UK:** Union Reality's PC headgear peripheral arrived in the **Edge** office this month, and brought with it some amount of interest. Ideally designed for flight sims, it replaces the lookaround facility usually assigned to a mouse, but proves just about unworkable with titles such as *Half-Life*, devilled as it is by continual fiddling with sensitivity levels. Side effects, meanwhile, include a crooked neck and hot ears. And even putting the thing on the right way proved too taxing for some test subjects...





## Girls power AOU

### Classics in Color

**UK:** Typifying the complexities of game licensing, the fabulous classic shoot 'em ups *R-Type* and *R-Type II* are headed for Game Boy Color. London-based conversion specialists Bits Studios signed up the worldwide rights from original developer and publisher Irem before relicensing to Nintendo for the Color.

Containing both the original titles (in mildly re-worked form), a save facility, and new interpretation *R-Type DX*, the cart will be nothing if not good value. *DX* is a medley of both *I* and *II* with snazzy new graphics and – remember this? – parallax scrolling. Not bad. And although Bits hasn't had access to any of Irem's code, it created the previous monochrome version for the chunky old Game Boy, so it should be able to produce a fine game for the Color. Either that or **Edge** sends the heavies 'round...



**Japan:** Attendees of the recent AOU exhibition tired of the lure of things that go bleep had a surfeit of peripheral attractions to divert their attentions

– namely a line-up of fillies eager to demonstrate their company's wares or simply stand around as items of decoration. Here's this year's gallery...



One of Capcom's staff presented *High-Power Businesswoman Sim*



Play *Dance Dance Revolution* or chat to the Konami rep? Hmm...



Not sure about these girls' names, but Naomi's lurking somewhere



*GP500* was one of the few disappointments on Namco's stand



Jaleco's stand was the spangliest – and that was just the outfits



Bub (or is it Bob?): the happiest dinosaur at the event



"Have you seen my dinosaur around here at all?"



Namco's stand: an ideal stopping-off point for weary showgoers

Photography: Hiroaki Izumi



# FutureGamer

## Delivered free, once a week



Gamers need sustenance: N64, PlayStation and PC news to digest, previews and reviews to gorge on and tasty features topped with flowing opinion columns for pudding. FutureGamer feeds that hunger, and because it's an email, it's delivered to you free, every week. Who says there's no such thing as a free lunch?

## Feed your hunger

Tuck into FutureGamer at [www.futuregamer.com](http://www.futuregamer.com)

### It's lip-smackingly good



## Crown jewel cases

**UK:** 'Nobody ever bought a record cos they liked the cover' is the opening statement of *Sampler*. Considering some of the examples on display here, if it were true, there would be some pretty full record label warehouses. Contrary buggers, then, these record sleeve designers. But despite the fact they have to concentrate on jewel cases and CD-sized covers, rather than old-style gatefold LPs, they are still innovating, and still selling records. Collected together by Intro, itself famous for work with Primal Scream, and Depeche Mode, *Sampler* shows off some pretty

impressive work. Other designers featured include Tomato (whose Underworld links have brought about its most widely known work), Designers Republic (Autechre) and Vaughan Oliver (v23). Just remember, it's one for the coffee table rather than the turntable.

*Sampler* is published by Laurence King, £20.

An exhibition featuring original work from the book will run at the Levi's Store, 174 Regents Street, London until May 16.

Design innovation among the pages of *Sampler*, a pornographic tome for graphic visionaries

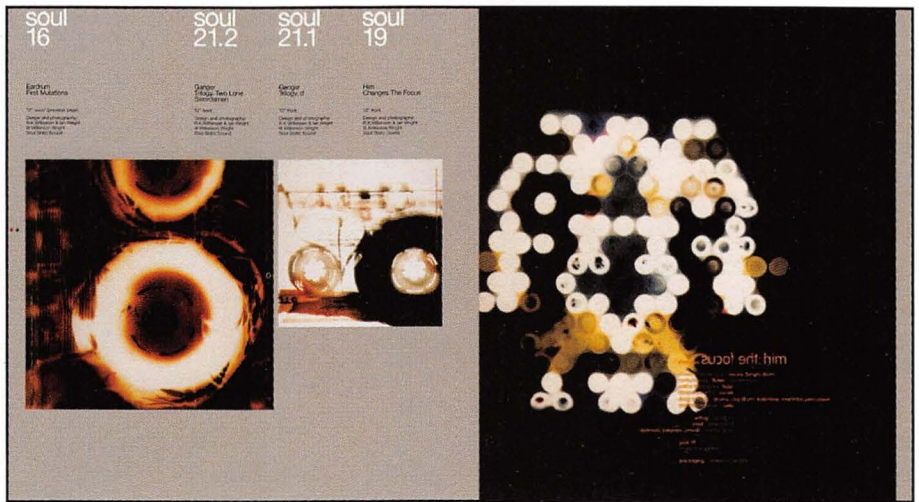
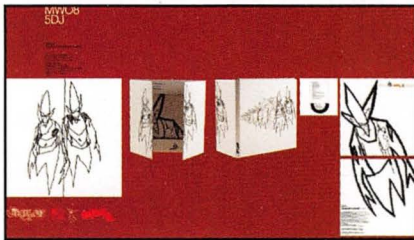

## 'Crash' and bum?

**USA:** After his trashing of 'Crash', **Edge** was concerned to learn that David Cronenberg's latest film is about computer games. And while 'eXistenZ' is an interesting attempt to explore photorealism in games, it's really more telling of Cronenberg than it is gaming, with heaps of his trademark ickiness. Not least this is because the kidney-shaped metaflesh gamepods of the future are made from mutated amphibian organs. They also plug straight into the nervous system via a bioport stamped into the base of the spine – cue all manner of multiplayer-asexual-orgy metaphors. This is fine when Jennifer Jason Leigh is head-to-head with Jude Law, yet it wouldn't work *quite* so well if you were online with the jocks on MSN Gaming Zone.

The plot, such as it is, focuses on Leigh, the greatest games designer in the world. Following a demonstration of her latest game, *eXistenZ* (think *Shenmue* running on the next generation PlayStation), she finds herself on the run from an anti-gaming realism group. Worried that the game is damaged, she persuades Law to play it with her. When in the game, they're chased by the aforementioned group. Then everything becomes even more complicated with the 'Is this reality or is this a game?' conundrum featuring heavily. Unsurprisingly, the ending relies on cinematic sleight of hand to sort out the mess. Somehow you can't imagine Yu Suzuki quaking in his virtual boots just yet.



Law brandishes a flesh-and-bone gun (above), while Leigh goes all gooey in the sack (right)

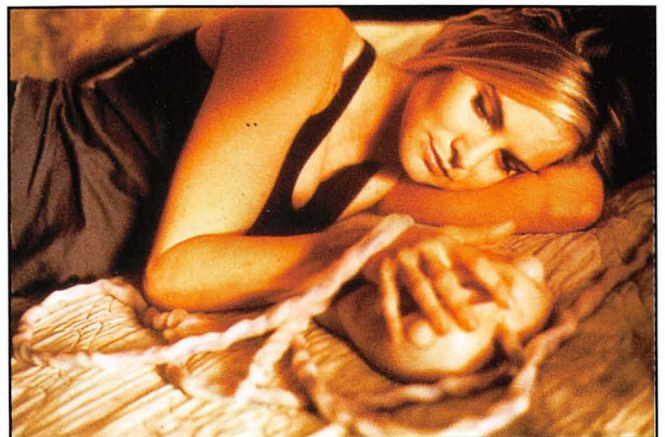



**ORBITAL**  
**The Middle Of Nowhere**  
(ffrr)

With dance music in decline, the time is ripe for old-timers such as Underworld and Orbital to show off new tricks. But whereas Underworld picked up the pace, Orbital remains in the shadows. You can't imagine a dancefloor heaving to these sounds. Even the sampling of the theme tune to 'John Craven's Newsround' has an ominous undertone, while 'Nothing Left Parts 1 & 2' does little to lighten the mood either. Pre-Millennial Tension strikes again.



**MOGWAI**  
**Come On Die Young**  
(Chemikal Underground)

Considering its reputation as one of the loudest, most discordant bands since My Bloody Valentine, Mogwai's new album is a surprise. With Mercury Rev producer Dave Fridmann at the controls, gone are the deafening peak-to-trough bursts of feedback, replaced by almost pastoral layers of sound. Some piano sneaks on to one track, while a waltz is manifest on another. Thankfully, though, its fearsome grasp of rock dynamics remains. Glasgow's noiseniks may have gained volume control but still remembers how to get the pulse racing.

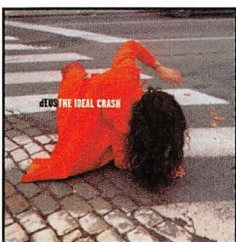

**dEUS**  
**The Ideal Crash**  
(Island)

Starting with a stab of white noise, dEUS seems determined to remain uncommercial on this, its third album. The more avant-garde '90s rock gets, the more it delights the critics and confuses the public. 'The Ideal Crash' will only widen that gap. But listening opens up the melodies and draws out the intricacies of interlaced violin and trumpet parts. This isn't an obvious record – even for dEUS. It's more like a soundtrack to the silent movie they never made.

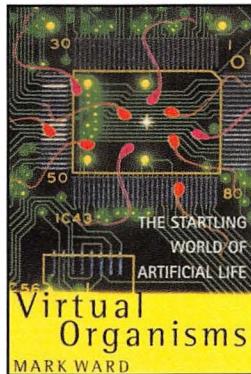

**Author: Mark Ward**  
**Publisher: MacMillan**  
**ISBN: 0 333 72482 8**

**VIRTUAL ORGANISMS**

"It lives," cried Dr Frankenstein after passing several thousand volts through his monster. Computer scientists have attempted to emulate this feat in the field of artificial intelligence for the past 50 years. Alan Turing's famous test is perhaps the most notorious: if you have a conversation with a person in one room and a computer in another, and can't tell which is which, the computer is intelligent. But, as Mark Ward suggests, there are other forms of intelligence in the world. Robotics expert Mark Tilden measures the intelligence of the machines he builds with a 'Purring Test'. If he can convince his cat that a robot is alive, then it satisfies many of the basic attributes of a living object. Welcome to the crazy world of artificial life.

A-life may be a backwater, but at least it's a fun one. The mass of strange characters that litter A-Life's history are proof of that. Ironically, though, Ward manages to kill off the subject with his dry prose. Maybe it's just another nail in the coffin of paper-based media – you get the impression that a CD-ROM version could be sensational. More worryingly, why no mention of *Creatures*?

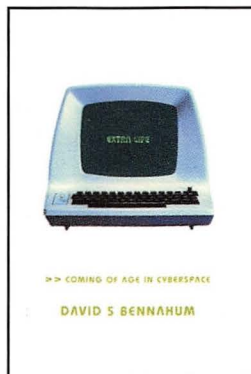

**Author: David S Bannahum**  
**Publisher: Basic Books**  
**ISBN: 0 465 01235 3**

**EXTRA LIFE**

The geeks have already inherited the earth, but it seems they're moving in on popular culture as well. 'Wing Commander' the movie is out, Hollywood is preparing for 'The Pirates of Silicon Village', a biopic of Bill Gates and Steve Jobs, and MIT Press promises a thick tome on the history of videogames. Even lowly journalists are getting in on the act, witness this, David Bannahum's *Extra Life*. Part autobiography, part social history, it chronicles the life of a kid growing up with computers in the early '80s. Plenty of 30-somethings could tell similar stories, but Bannahum neatly treads the line between the cloying details of his life (uninteresting) and the changes in New Yorkers when they come into contact with PCs (far more interesting).

As well as excitement, there is also poignancy in the way these poor rich kids escape the real world of divorced parents into the embrace of the school PDP-1. It didn't matter whether you were good at sports any more – you could be good at playing games instead. This proved to be a radical change for American society, too, as proved by the success of titles such as *Deer Hunter*. Now we are all digital. The geeks didn't just inherit the world, they fundamentally changed it. *Extra Life* may be just one of a million stories, but you're unlikely to read any told better.

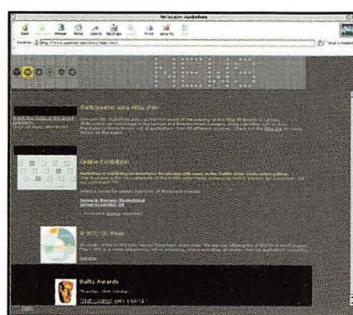
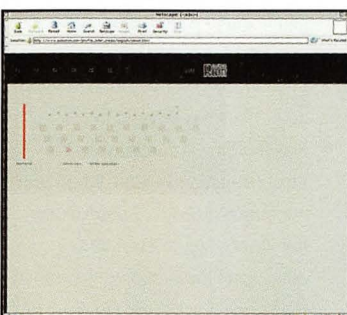

**INTERNET**

**Site: Audiorom homepage**  
**URL: [www.audiorom.com](http://www.audiorom.com)**

After defeating all-comers at both last year's Baftas and February's Milia D'Or awards with its *Shift Control* multimedia work, London-based Audiorom is in a strong position for 1999.

For those seeking to sample some of the company's creative excellence, look no further than your Internet browser. Audiorom's homepage has several online 'interactive toys', including an interpretation of *Breakout* and several music sample-based offerings with which to while away a beat-filled break. With breakbeats, in fact.



## VIEWPOINT

EXPRESS YOURSELF IN **EDGE** – WRITE TO: LETTERS, **EDGE**, 30 MONMOUTH STREET, BATH, BA1 2BW (email: [edge@futurenet.co.uk](mailto:edge@futurenet.co.uk))

**N**ow that Sony has spilled the beans with details of its forthcoming PlayStation 2, I see no hope for Sega, which is reluctant to produce anything but arcade conversions. I find it most disturbing that after buying a Dreamcast I have actually bought into a franchise that was backed up by a lot of hype and expectations it could not meet. I want to see depth, imagination and new innovative ideas in my Sega games which, while high quality, do not match their Model 3 equivalents in graphical flair. Maybe you could say they offer the same degree of playability, but you could argue that it should have been the media alone making the hype for what is a truly awesome machine and not Sega, which doesn't have the right R&D teams to support it.

On another note, I have the utmost respect for Yu Suzuki, but his lack of commitment for the standalone Dreamcast is already becoming apparent. Opting to use Naomi's scaling capabilities only creates more concern for the potential western buyer. Again it seems that Sega's machine will be unsupported by its best man. *Shenmue* is obviously a big game for Sega and Suzuki-san, but that's just one game and most punters are looking at the long-term future. Suzuki-san needs to take a leaf out of Namco's book and support the standalone hardware, make great games and deliver. It is something that a lot of people would like to buy into, but Sega seems reluctant to change. If Sega makes the right moves now, it will not feel the pressure so much come December, when Sony will unveil an awesome machine in Japan and will only have to worry about a pricing

strategy to blow Sega out of the home market for good.

**Richard Stringer,**  
via email

**F**our long years ago my family invested in a brand new Dell Precision 560. It was top of the range back then and could play all

period of time – maybe even a year or two. Why? Well, look at the average console's life – three to five years. Now look at the PC games I was playing four years ago on my Dell, and now look at the PC games of today – *none* of them will work on my machine. The PC games of today will easily work on the

'If Sega makes **the right moves now**, it will not feel the pressure so much come December, when Sony will only have to **worry about a pricing strategy** to blow Sega out of the home market for good'

the great PC games at a stonking speed. Over the years I realised that I was able to play a smaller and smaller selection of the new games being released due to the rapidly increasing specifications of the PC.

Dreamcast, but in a year or so, with P4 700s and probably minimum specs of 3-400MHz and 64Mb of RAM becoming standard, the games are going to have to be significantly altered to get them to run smoothly

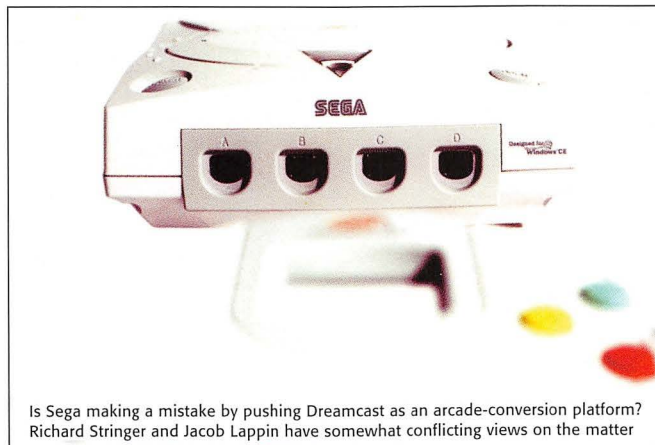

Is Sega making a mistake by pushing Dreamcast as an arcade-conversion platform? Richard Stringer and Jacob Lappin have somewhat conflicting views on the matter

My point is regarding the Dreamcast. Sega has made it very clear that the majority of the Dreamcast's software catalogue will be made up of quick-to-produce PC ports and fairly easy-to-do arcade conversions, and I'm concerned that soon the claimed two months it will take to do these PC and arcade ports will become a rather longer

period on the Dreamcast. By then nobody will want to play them as they'll look shoddy in comparison to the PC counterparts. Even games being developed now such as *Quake III* will be unlikely to run on a Dreamcast. Imagine games in three years' time!

'Never mind, though,' you'll probably say, 'by that time there will

be enough Naomi-Dreamcast arcade ports and enough original games to keep you going.' Wrong. Sega is already increasing the power of its arcade games. Look at *Ferrari F355* – it uses four(!) Naomi boards. I doubt it'll be long before most Sega games are using more than one board. I think there may not be as many coin-op conversions as Dreamcast owners would like, and isn't that the main attraction of any Sega console – the prospect of being able to play Sega's arcade gems in your living room? So, three or four years down the line I see the Dreamcast without most of Sega's arcade hits, or any of the PC's great games, all of which breaks the Dreamcast's main selling point. We can only hope Sega has realised this oversight and has got more Dreamcast-specific games other than *Shenmue* to come.

**Jacob Lappin,**  
via email

Two Sega fans, one opposed to coin-op conversions, the other all for them. If Sega's devotees are this disparate in their desires, surely its job is set to be ever more difficult.

Regarding original DC software, Tetsuya Mizuguchi (of *Sega Rally 2* fame), at least, is currently working on a major Dreamcast-specific project which promises to be vastly different to his previous titles. You'll read an in-depth report on the game within these pages soon.

**I** worry that the problem which I feel has dogged the PlayStation will continue on the next generation version. When Sony announced the PlayStation, many frankly average or even bad developers jumped onto the format to make a quick buck, churning out



crap or, at best, average titles, and continued to do so throughout the life of the machine. True, the PS has hundreds of games, but how many are released on the quiet in order to catch out unsuspecting punters? How many of these games are new crap games or just crap rehashes of old games? The PlayStation still now has only about 30 games worthy of attention, and in my opinion only five or six classics at most (eg, *Final Fantasy*, *Gran Turismo*, *Metal Gear Solid*, *Tekken 3*). With the N64, we have the other side of the coin. The N64 has more good games in comparison to bad games, and more classics (eg, *GoldenEye*, *Mario 64*, *Zelda*, *F-Zero*), but, unfortunately, very few games at all in comparison to other systems, due to Nintendo's fussy development attitudes.

Still, I really do hope that the NGPS can hit the middleground here, and that Sony can undertake Nintendo's selective development policy and only let their new baby be blessed with great games, instead of piles of half-finished titles, rushed titles, remakes of crap games, or just plain awful games. All it needs to do is have a little self respect and not allow its own market to be cluttered up with dire titles, which is what was allowed to happen on the PlayStation.

However, for that particular state of affairs, the blame does not lie solely with Sony. Developers should concentrate their efforts on original ideas and high-quality games, without bothering with low-rate titles, which can basically be described as fillers made quickly to get the money rolling in. The finest exponent of this policy is Electronic Arts. Call me cynical, but it brings out the same game (*FIFA*) three

times a year instead of coming up with new ideas. I'm just worried that with this attitude, if allowed to carry on to the next generation of superconsoles, we, the gameplaying public, will be led round in the same circles.

**Alex Parratt,**  
via email

Ever since videogaming began, there's always been below-par software and there always will be. Sony may have revolutionised the industry in some respects, but this is something it can never conquer.

I've been reading **Edge** for over three years now, and have followed the pro-/anti-piracy debate in your letters page with interest. But nobody seems to have mentioned the category of 'pirate' that I, and many others, fall into. Firstly, not *all* piracy is bad – you can't tar us all with the same brush. Grey importers who 'pirate' the publishers' rights to sell games in the European union are hardly a menace to society, but it's still piracy

'Do they really expect me to wait six months for a substandard PAL version and say 'Okay'? No way. If they're not going to respect me as a valid consumer, then screw them'

and yet you're happy to place their adverts in the back of the mag. In my opinion pirates who copy games and sell them on to make a quick buck are the bad guys, and should rightfully be prosecuted.

I myself am active in piracy and own a CD burner, PC, N64 and V64, modded Japanese PS and will have a modded Dreamcast as soon as it's available. My reason for piracy is not about saving money, though. A

quick calculation shows I've spent over £2,000 on hardware in the past two to three years alone (not including air flights to Hong Kong to purchase the equipment). I'd much rather that this cash went to the teams for producing the games, but why the hell should I wait an eternity for the Japanese giants to get their arses in gear and release the shitty, substandard PAL version when I can pirate it on its first day of release (and in many cases, before release) and get a faster version? Let's take some examples: I got *Tekken 3* upon its release in Japan and enjoyed it immensely. However, some three or four months later, PAL *Tekken 3* arrives here and plays like treacle – nobody in the UK could get the combos, juggles and reversals timed on the PAL version. Then, of course, there's *Metal Gear Solid*. Do they really expect me to wait six months for a substandard PAL version and say 'Okay'? No way. If they're not going to respect me as a valid consumer who would happily hand over £50

of my hard-earned cash for their game, then screw them. I'll connect to a site, download the disc in little under an hour, and be playing it the day it's released in Japan.

Unfortunately, the *huge* expense I've endured in order to ensure that I have the latest games means I have little disposable income left to buy legitimate games (although I've always gone out of my way to reward titles that didn't take the piss – ie,

*ISS64* and *TOCA 2*, both available here before anywhere else).

However, while game companies continue to treat me like a second-class citizen and are happy to screw Europe over, I'm more than happy to screw them over in return. Please don't respond with 'The situation will not change until people like you buy games legitimately' – I am merely a product that the games industry itself created. It's up to them to make the first move.

**Oday Pir8,**  
via email

In terms of morality, your actions are leagues apart from those who import software to the UK – lumping yourself together may ease your conscience, but it's a simple untruth.

I've read your reviews of *Sonic Adventure* and *Sega Rally 2*, and I totally agree with your opinion: both games were rushed and suffer slowdown and pop-up. Pierre L and Mr Mackintosh must have different versions to the ones I have...

**Gary Rose,**  
via email

In response to Pierre L and Stephen Mackintosh in E70, you guys are failing to look at the games industry in a non-biased view. I suppose your football team, Formula 1 team or whatever can do no wrong either. **Edge** seems to be the wrong magazine for you.

**Richard Pearson,**  
Nottingham

Congratulations on your 'SpuriOS' story [News, E70] – it was the best April Fool I've read, and it convinced quite a few of my friends.

**Steve,**  
via email

# wipzout 3

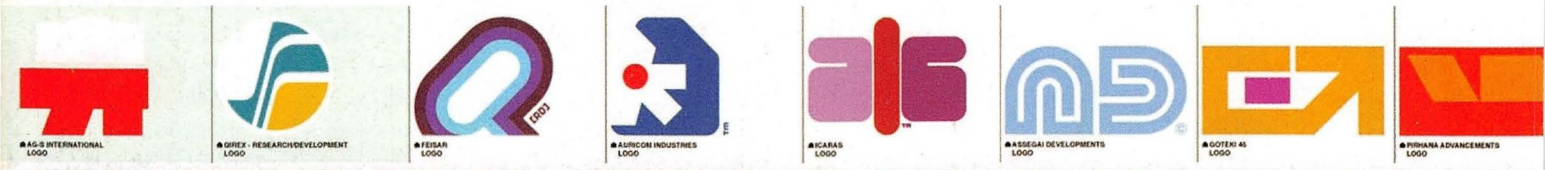

NEXT MONTH: THE RETURN OF THE  
GAME THAT KICKSTARTED AN ERA

ISSUE SEVENTY-TWO  
ON SALE MAY 19

SCORE<1> HI-SCORE SCORE<2>  
7250 9370



0 CREDIT 00

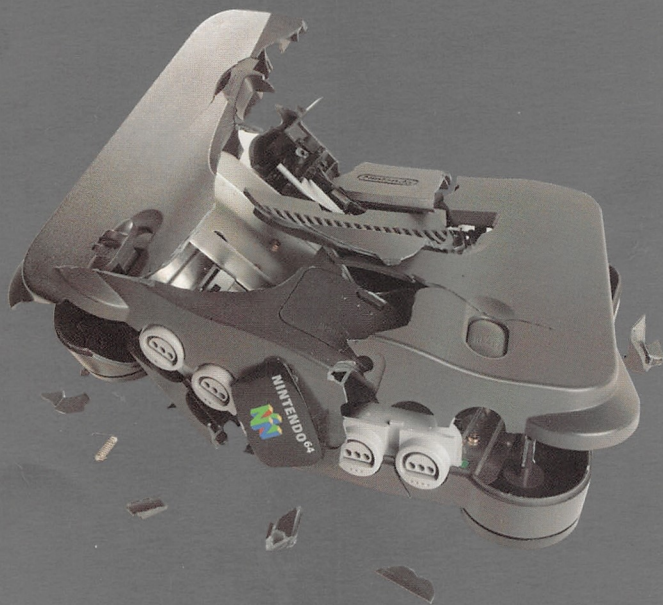

**future**  
PUBLISHING  
Your Guarantee  
Of Value

