

BRITAIN'S BEST-SELLING SPECTRUM MAG!

YOUR SINCLAIR

FEB
1992
No 74
£2.20
With
Lump
Free
Tape

NINJA NUTS!
Double Dragon 3 Previewed inside!

WORLD EXCLUSIVE! G-LOC

SUPER-SONIC HIGH-FLYING FROLICS FROM US GOLD!



Sorry Spec-chum, but there should be a tape here. Why not ask the newsagent if it's out the back with the unsold copies of the 1972 Mary, Mungo and Midge annual!

1		2			3	
4						
5					6	7
6		9				
10				11		12
		13	14			15
16						

TURN TO PAGE 49 FOR THE CLUES

TONS OF SPECCY GAMES!

Check out the car-racing hilarity of **Cisco Heat**
● Marvel at the incredible **Wile E Coyote** ● Bash the wings off defenceless cars in **3D Stock Car** ● Plus! **Eat dirt, the Speedway!**

PLUS! Find out what the best Speccy game of all time is! Thrill to the YS crew's exploits at **Buckingham Palace!** And, learn the **Fun School Way!** Delve inside the best Speccy mag in the world!

future
PUBLISHING

Your guarantee of value



9 770269 698034

Shy.
Sensitive.
Law-abiding.
Polite.
Respectful.



BRUCE WILLIS

HUDSON

HAWK

...I don't think so.

Now...
steal in on the game.



© 1991 TRI-STAR PICTURES, INC.
ALL RIGHTS RESERVED

OCEAN SOFTWARE LIMITED . 6 CENTRAL STREET . MANCHESTER M2 5NS . TEL: 061 832 6633 . FAX: 061 834 0650



This is Andy the Ed's mum, Pat. So Mrs Hutch, what was Andy's worst habit? "He had to be first everywhere, first to the shops, first up the path, first to the car..." Yes, thanks mum. Who's next...



Ah, that'll be Andy Ousted's mum. So, Mrs O, what was our Art Ed's worst habit? "He'd always fall off his bike. He had the balancing skills of a stork with a broken ankle..." Ah yes, who's that...



Gosh! James Leach's mum, Liz! Well, Mrs L, what was our Games Ed like as a boy? "He was always really grumpy first thing in the morning." Is that it? "Erm, yes, he was a sweetie!" Hmm...



Hi ho Mrs Barker, what was Linda the spog like? "She was a lovely baby. However," Yes! "She used to bite her little brother's toes under the table!" Right, now who's that...



Hiya Mrs Booth. Go on then, dish the dirt on Maryanne, "She'd never go to sleep, I had to sit there for hours. Lord knows how many editions of the Generation Game I missed!" Fine!

Another year, another 365 days. We've made quite a few new year resolutions here in the shed. Personally I've decided to brush up on my pulling-skills. You see, I got spotted in the street the other day by this very attractive young lady. However, instead of asking me for a good snog, she merely wanted to know how I could possibly like a band as crap as EMF. It wasn't a very pleasant

experience I can tell you. Anyway, if any YS readers have got handy hints or tips for me, then drop me a line explaining where I'm going wrong! Right on with the magazine, oh and remember team: take nobody's word for anything! Cheers,

Andy

THE MAGNIFICENT 7

THE ACTION STARTS ON PAGE FOUR

EXCLUSIVE PREVIEW!



DOUBLE DRAGON 3



PLUS!

FULL GAMES OF SPACE 7 & 3D LUNATAK, AVALANCHE DEMO & LOADSA POKES!

14 Cisco Heat
Manic police cars whizzing around San Francisco. Sounds like a great plot, but is it a good game?

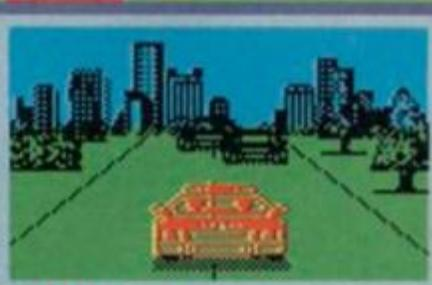

Double Dragon 3: Megapreview 26
Karate kicks and smashing bricks. How's it looking?

The Top 100!
45 Finally, after all these months we get to the crowning glory of Specky games... erm, maybe!

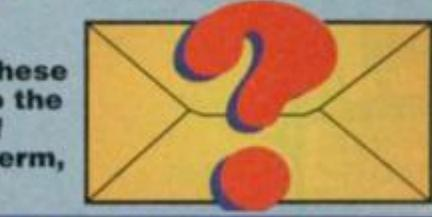

BACK TO OUR ROOTS?

YOUR SINCLAIR We're not talking about the roots in the land, we're talking 'bout the roots in the man!
 Editor: Andy (Manchester) Hutchinson ▼ Art Editor: Andy (Bristol) Ousted ▼ Games Editor: James (Hamelin) Leach ▼ Staff Writer: Linda (Hackney) Barker ▼ Art Assistant: Maryanne (Portsmouth) Booth ▼ Advertising Manager: Cheryl (Tunbridge Wells) Beesley
 ▼ Production Co-ordinator: Lisa (Bath) Read ▼ Publisher: Jane (Chelmsford) Richardson ▼ Publishing Asst: Michelle (Amersham) Harris ▼ Group Publisher: Greg (New Forest) Ingham ▼ Circulation Director: Sue (Guildford) Hartley ▼ Your Sinclair (London), Future (Somerton) Publishing, 30 Monmouth Street, Bath, BA1 2BW, Tel (0225) 442244 (Reader enquiries Wednesday only), Fax (0225) 446019 ▼ Subscriptions: The Old Barn, Somerton, Somerset, TA11 7PY, Tel (0458) 74011 ▼ Distribution: MMC, Tel (0483) 211222 ▼ Cover illustrator: Max (Wokingham) Ellis ISSN: 0269 6983 ABC: Jan-June 1991 65,444 ▼ Your Sinclair canters briskly into the paddock with a whinny and a neigh from the same stable as these fillies: Commodore Format (Bath), Amstrad Action (Somerton), Amiga Format (Bath), PCW Plus (Somerton), PC Answers (Bath), PC Plus (Somerton), Sega Power (Bath), Amiga Power (Bath), Amiga Shopper (Bath), Classic CD (Bath), Needcraft (Bath), Mountain Biking UK (Faversham), PC Format (Bath), Public Domain (Bath) and ST Format (Bath).
 But what we really want to know is... who invented liquid soap, and why?



REVIEWS

- 10 G-Loc
- 13 Wile E Coyote
- 14 Cisco Heat
- 16 Moontorc
- 16 3D Stock Cars II
- 18 Paperboy 2
- 19 Jimmy's Super League
- 19 International speedway
- 28 Bubble Dizzy
- 44 Big Nose
- 52 Picture Book
- 52 Count And Add
- 53 Fun School 4 - Under 5
- 53 Fun School 4 - 5-7

REPLAY

58-60 Three pages of the latest re-releases and compilations. Featuring... CodeMasters' Cartoon Collection, Hi Tec Hanna-Barbera Cartoon Character, Collection Superheroes and Switchblade

PREVIEWS

- 26 Double Dragon 3
- 64 Murray Mouse
- 64 World Cup

THE REGULARS

- 1 Rather Fetching Cover
- 4 The Mag 7
- 8 Pssst
- 11 Joystick Jugglers
- 21 Letters
- 25 Reader Survey
- 30 Adventures
- 33 Tipshop
- 38 Spec Tec
- 45 Top 100 - Part Five
- 46 Program Pitstop
- 48 Input Output
- 49 Crossword Clues/Back Issues
- 50 YS Subscriptions
- 61 YS/Mirrorsoft Hero Turtlesvideo & game offer.
- 65 YS Superstore
- 66 Next Month
- 94 The Bermuda Triangle

Give us a Y! Give us an S! What have you got - the best! Put your hands on your elbows for another scrummy round-up of games, demos and enough POKES to confuse a beaver.

SUPERSPRINT

Beau Jolly

COMPLETE GAME

It's an exclusive! Yes, *Your Sinclair* brings you the game that launched a thousand other games quite a bit like it, and many more which were totally different.

The idea is so simple a chimp could grasp it (especially if it was one of those clever tea-drinking, clothes-wearing ones). What you do is race round a circuit with three other cars. You've got to win by any means, fair or foul. Actually you can't really



Spanner alert! Drive over it to pick it up and you'll be rewarded with a bottle of champagne and a box of Milk Tray.

haven't got the reflexes of a particularly alert cat you'll be sliding all over the shop, shouting at the top of your voice for everyone else to stop overtaking you. Seeing as very few people have the responses of clever cats, everybody bashes into everybody else.

You can also let other human players have a go with *Supersprint* because there's a pretty spanky multi-player option. The more the merrier, as we so often say at YS.

Also, with about 12 circuits to race round, you shouldn't get bored with the scenery. Don't say we're not incredibly nice to you here in the Shed.



It looks pretty easy, but don't be fooled. This track is as difficult as climbing the north face of the Eiger using only a toothpick.

CONTROLS

Joystick or keys
6 Left
7 Right
0 Accelerate

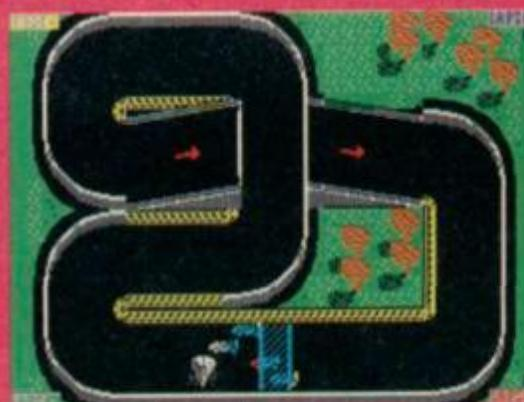

Ooh, look! There's some lovely flowers in the middle of the track. What a nice idea. How about rose bushes in the middle of runways?

play foul because you can't collide with the other vehicles. If you do, you just slide through each other like ghosts. This may sound like a bit of a bummer, but it means that you don't have to worry about getting through small gaps and stuff.

The big thing with *Supersprint* is that it's sooo quick. You really rocket around the track, and if you



TAPE TRUBBS

Every tape is lovingly hand-stitched out of Moroccan yoghurt for 100% success every time. But if yours does decide to misbehave, ram it into a jiffy and send it to YS Mag 7 No. 10, Tape Returns, Dept (Feb Ish), Ablex Audio Video Ltd, Harcourt, Halesford 14, Telford, Shropshire TF7 4QD. Simmer on gas regulo 5 and wait 28 days. Alright? Not half!



Get your spanners in! **SUPERSPRINT** is on page 4. And! It's a complete game. Yipee!

Learn about stones in our demo of **DOUBLE DRAGON 3** on page 5.



SPACE 7's on page 5. It's a complete game and it's spooky.



Turn to page 5 for some beautiful cheats. It's just super.

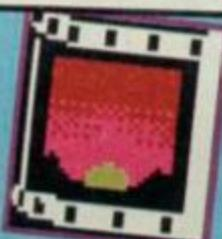

WILE E COYOTE AND ROAD RUNNER. It's a demo on page 6.



Earth is being attacked. **3D LUNATTACK** is a complete game.



Dodgy Italians on page 6. It's a demo of **AVALANCHE**.



DOUBLE DRAGON 3

Storm

PLAYABLE DEMO

The mean streets have just got meaner. Why? Because you're back.

Well, not you exactly. But Billy, the character you're playing, is back. He's the king of beating people up and he's out to kick loads of people and get his girl.

These streets are pretty exotic and far-flung. Y'see, the levels in *Double Dragon 3* take place in such places as Egypt, Japan and China. But that's the proper full game, this fully playable demo just includes the first level, set in the USA.

The main idea behind all this violence is that you've got to get your little mitts on the



Rosetta Stone. This is a (real) lump of rock with loads of ancient writing on it. It took the best archaeologists in the world years to decipher it, only to find it was a recipe for old-style flapjacks.

You've got to find the stones and hand them over to Black Warrior gang. In return they'll give you Marion back. Y'see, that's what all this manly fighting is about – a cute girly.

You've got all the training you need to get stuck in with the baddies. For major damage you've got the old punch, kick, and that fave, the flying kick. If you think that's weedy you can go into a weapons shop at the start of the game. When you enter, all the violence outside ceases. It's a quiet sort of shop, like the kind you see in the Cotswolds selling ancient fly-tying equipment and run by an old couple who... (get on with it! Ed).

You've got a load of credits which you can spend on extra lives and extra fighting moves. You then move back into the fray.



A record shop! This is New York so maybe they'll have some really cheap CDs. I won't even have to pay for them if I look like this.

As you fight, it's best to keep moving into a clear area. If you get into the middle of a crowd, you'll get punched and kicked from all sides, and once you fall you'll have a devil of a job getting up.

The demo runs for much of the first level, and you should finish it if you keep your wits about you. It's certainly an appetizer for the full game, which we should be reviewing next issue.

CONTROLS

Joystick or definable keys

SPACE 7

G D Shaw

COMPLETE GAME

Hmm, *Space 7*, eh? Sounds a bit like the Magnificent 7 or Blake's 7, you know, that rather sad show that used to be on at tea-time on Saturdays.

Do you remember the one where they dropped Orac (that crap square computer) and its top came off so you could tell it had been made out of Squeezy washing-up liquid bottles?

Anyway, *Space 7* isn't anything to do with Blake's 7 or anything else with the number seven in it. It is, in fact, a game which sets you up as a small semi-plastic AV8 androidy sort of robot in a spooky 3D sideways-viewed land.



Exterminate! Exterminate! These daleks, eh? Can't trust them a bit.

You chug around this place looking for the special mega *Space 7* Control Computer. And no, I'm not going to tell you what this looks like or where you can find it. You'll just have to take my word for it that when you come across it you'll certainly recognise it – it, erm, looks like a big control computer.

You move around by using O and P to aim yourself, then hitting Q to get some speed up. It's pretty easy and you should have no trouble if you keep your speed down. Going too fast is the only thing that can really muck you up. So remember, kids – speed kills.

Oh, and one other thing that can also kill you is the enemy. This is a bit of a downer cos there are loads of enemies and you've thus got a very high chance of being killed.

They patrol certain areas so you can dodge them if you're clever, but if they so much as graze you, you're dead meat, or plastic or whatever.

Pressing M transforms



Aren't those hearts sweet? In fact, the whole thing looks dead nice and not at all grim. But grim it certainly is.

you into the special high-speed mode, but to collect useful objects (such as explosives) you must be in normal android mode.

The rest of *Space 7* you can find out for yourselves. You know the scenario, you know what you've got to do. Now go off and do it. Oh, and jolly good luck – the rest of the universe is counting on you.

CONTROLS

Q Forward
O P Left
P M Right
M Change Mode
Y Abort

POKERAMA

Jon North

Jon had planned to go over a huge waterfall in Canada inside his mum's biscuit barrel this week. But as he was psyching himself to do it, his mum found a pile of Custard Creams behind the sofa, where Jon had hidden them. She put them back in the barrel, and Jon went round his mate's house instead.

Somehow, amidst all this excitement, Jon managed to get together some world-famous POKES. In fact he managed to get

them blessed by the deputy heads of all the world's major religions, so they can't fail. *Mined Out* Immortality (again!)

Shadow Of The Beast Infy lives

Ghouls 'n' Ghosts Infy lives

Lotus Esprit Turbo Challenge

Always quality

Impossamole Infy energy

Venturama Infy lives

Sky High Stuntman Infy takes

Round The Bend Infy time



Sewers look quite nice from this angle. With Jon's help you can spend as much time running in and out of these little holes as you want. Good, eh?

ROAD RUNNER AND WILE E COYOTE

Hi Tec

PLAYABLE DEMO

This is one of those timeless and classic cartoons that you can wake up to watch on Saturday mornings (if it's still on) and you can guarantee that within 0.13 of a second you'll be laughing your bedsocks off.

So you'll be more than delighted to hear that you can play the game on a Speccy near you. Hi Tec, those wacky Sheffield-based, er, people have got the rights to many, if not all, of the Hanna-Barbera titles, so this one is just the tip of the iceberg.

What you must do is move the Road Runner left and right, avoiding the objects

being dropped by Wile E Coyote as he jets his way past on an ACME rocket pod.

As well as keeping out of the way of the bombs, anvils



Free bird seed, eh? Let me at it, Mr Coyote! You'll have to jump over that worm first though. Good luck!

and other nasty bits and pieces he's dropping, you must steer clear of any creatures rushing around on the ground. Sound tough? It most certainly is.

And what makes it even tougher is that you have to collect certain objects as well. You see, the Road Runner needs food and stuff as well, and you've got to grab all the nosh you can find. Some objects give him extra speed, some give him much higher jumps. You've got to survive for 80 seconds before you've beaten the level.

Road Runner And Wile E Coyote is for serious players only. It really requires some nifty gameplay from you!

CONTROLS

Keyboard or joystick

Q	Up
A	Down
O	Left
P	Right
SPACE	Fire
F	Freeze

AVALANCHE

CCS

PLAYABLE DEMO

It's war! The year is 1943 (ish). The Germans are packed like sardines in Italy, it's getting towards the close of the Second World War, and you've either got to get the germies out of Italy using your Allied troops or, if you're playing the Germans, keep them there.

You move from unit to unit, scrolling around the map display with the N key (taking you to the next unit with no orders). All you need to do is press H to hold, M to move across country or R to move along a road.

To enter into combat, simply wait for your movement phase then select each of your units in turn (here's where the N key comes in so useful). Move them using either M or R, right up next to an enemy, then choose where you want them to end up using the cursor keys and RETURN.



Ahh, those names! Parma ham, the leaning tower of Pisa, Livorno sausage. Actually, I made the last one up. (Never? Ed)

of supply. It makes a lot of difference to the way they fight. If they're really knackered and you send them in to fight anyway, they'll put up a bit of aggro then disappear in the opposite direction. Serves you right for trying to get them to do too much.

If you can wipe out all the enemy on the map, you've won. However, there are only a limited number of turns allowed. Kill the enemy in this time and you're doing extremely well indeed.

CONTROLS

R	Recce
S	Strafe
X	Exit current mode
Cursor Keys	Movement
M	Move
R	Move on road
N	Next unit
S (in movement phase)	Stats

3D LUNATAACK

Hewson

Time for a bit of space combat, methinks. Pay attention cos it's going to need some hefty explaining.

Y'see, the baddies have invaded the moon and they're heading towards your base (marked F on the map). Oo-er! You've got to destroy their forces, both on the ground and in the sky.

To help you, there are three main combat modes. There's missile mode, where the gunsight is square and above the horizon; laser mode, where the

gunsight is below the horizon and octagonal. Finally there's navigation mode, where the gunsight is one the hull and diamond in shape.

Missile mode is used to destroy enemy fighters beyond visual range. You simply align the gunsight, fire and forget. Laser mode is used to attack all visual enemies. Nav mode allows you to follow your computer's preset course.

Watch your fuel and temperature, if they look dodgy, return to base (using Nav mode). If they're okay, fly around blowing everybody to pieces. And that's it.

CONTROLS

Keyboard	Joystick
WERTYUIO	Up
ADGJ	Left
SFHK	Right
ZXCVBNNM	Down
Space	Fire

NAVIGATOR

**BREAK THE
PERFORMANCE
BARRIER...**

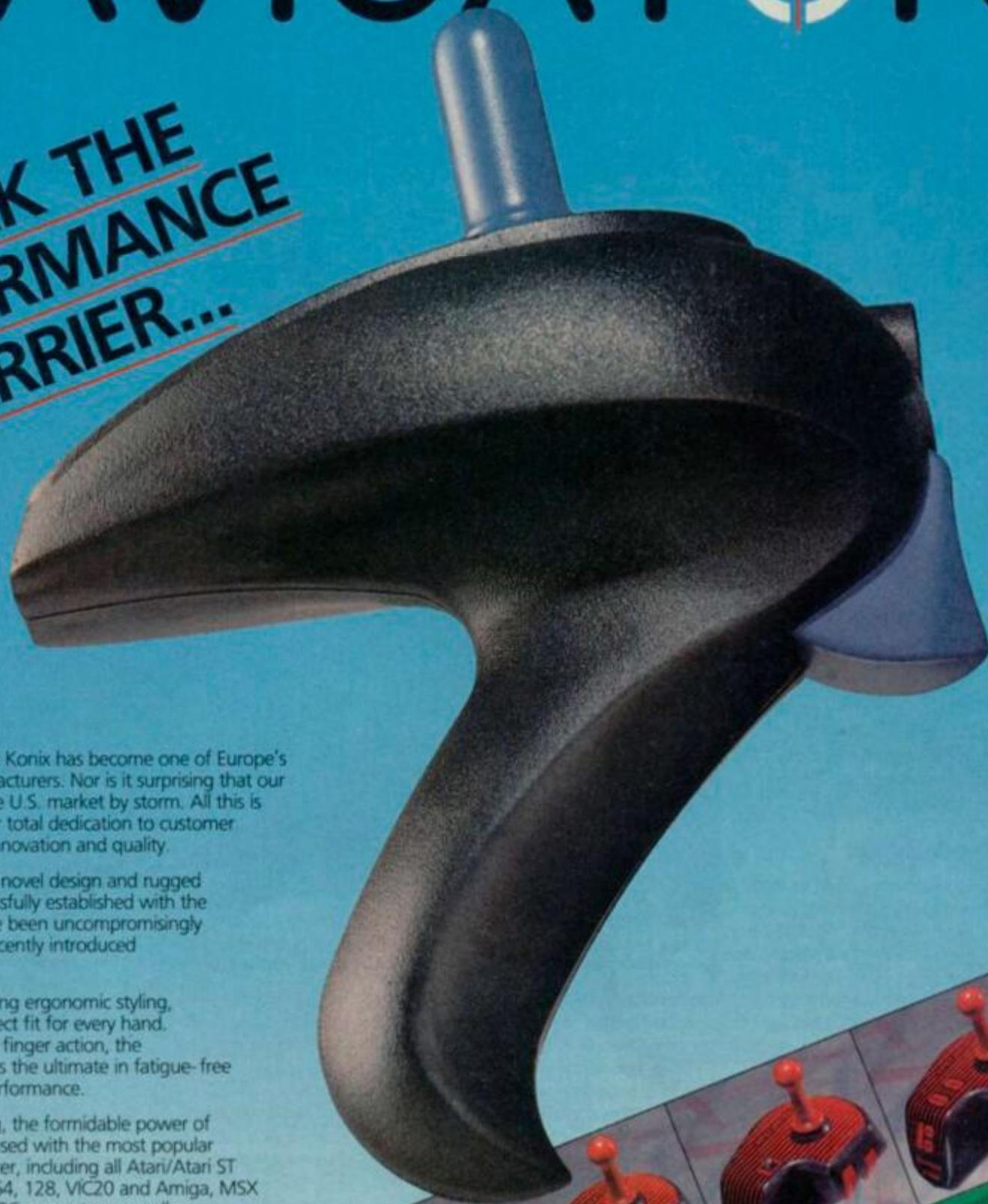

It is not by chance that Konix has become one of Europe's leading joystick manufacturers. Nor is it surprising that our products are taking the U.S. market by storm. All this is simply the result of our total dedication to customer satisfaction, through innovation and quality.

The same principles of novel design and rugged construction, so successfully established with the SpeedKing range, have been uncompromisingly applied to the more recently introduced Konix Navigator.

Thanks to its outstanding ergonomic styling, the Navigator is a perfect fit for every hand. With its natural trigger finger action, the Navigator truly achieves the ultimate in fatigue-free super-fast precision performance.

Just like the SpeedKing, the formidable power of the Navigator can be used with the most popular types of home computer, including all Atari/Atari ST models, Commodore 64, 128, VIC20 and Amiga, MSX computers, Amstrad CPC computers as well as Spectrum Plus/Plus 2 and Plus 3.

Even for the most demanding enthusiasts, you can be sure that Konix joysticks will make the performance barrier a thing of the past.

KONIX
COMPUTER PRODUCTS

The fastest reaction in the business

Export Enquiries: Konix Computer Products, Unit 35, Rassau Industrial Estate, Ebbw Vale, Gwent, NP3 5SD.

Distributors:

■ Capri Marketing Limited
9 Dean Street, Marlow,
Buckinghamshire SL6 3AA

■ Centresoft
Units 2/3, Holford Way,
Holford, Birmingham B6 7AX

■ Columbus
Unit 2, Wren Nest Road,
Glossop, Derbyshire SK13 8HA

■ GEM Distribution Limited
Lovet Road, The Pinades,
Harlow, Essex CM19 5TB

■ Lazer Distribution
Unit 2, Kingsgate Business Units,
Duchy Road, Heathpark, Honiton,
Devon EX14 8YD

■ Leisuresoft
Unit 65, Sketty Close,
Brackmills Industrial Business Park,
Northampton NN4 0PL

■ SDL
Unit 10, Ruxley Corner Industrial Estate,
Sidcup, Kent

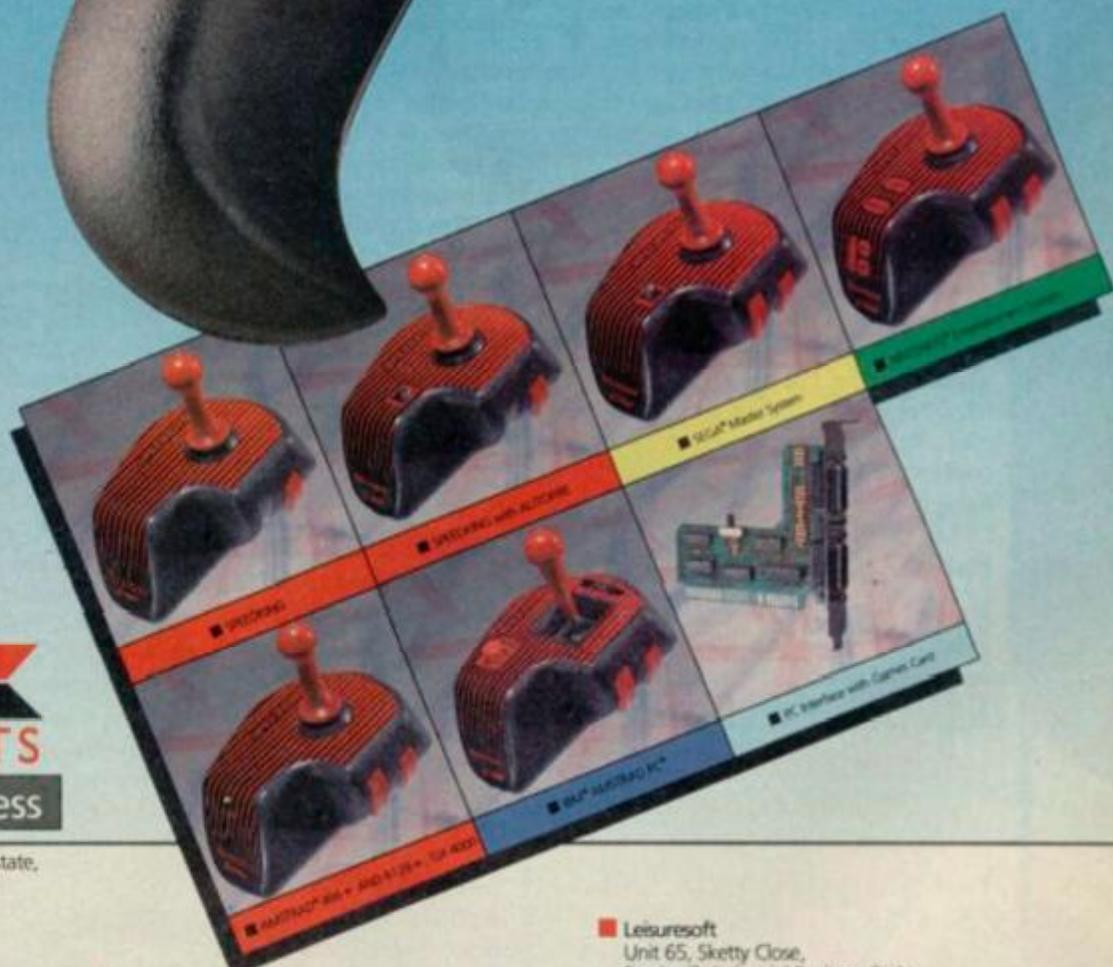



Pssst



THE FAB FIVE HIT TOWN

A special report from Arabella Ponsonby-ffoulkes-Hall.

The nation rejoices as the country's favourites get a bit of right royal recognition. Yep, the Queen Mother is the YS team's biggest fan. According to our Royal correspondent, Jeremy Forsecorn-Smythe, the good old Queen Mum likes nothing better than a good larf. She has often been spotted in a tatty but comfortable chair with a packet of shortbread and a copy of *Your Sinclair*. "It keeps her occupied for hours," says Jeremy, a 32 year old royal carpet cleaner.

Buxom Red-head

A Royal insider informed us that the Queen always looks to her mother for inspiration when she's compiling her New Years Honours List. "She hates doing it," said our buxom red haired source who must remain nameless. The Queen Mum persuaded Elizabeth Jnr that the YS team were the nation's faves and she'd be dead popular with the kids if she gave them an award of some sort. Young Liz wasn't so sure, but her mum gave her a copy of YS to take away and read. An hour later the Queen was convinced that it was the right thing to do.

Bacon And Eggs

Today, the Fab Five went to the Palace to pick up their MBEs for



It's the Fab Five! They look smart now, but in a few years time they'll all have long hair, furry kaftans and bottles of patchouli oil in every pocket. How the mighty are fallen!

services rendered. Not since the Beatles received their honours have such bright young things been honoured in this manner. Royal housemaid, Claire Green, said that the Palace hasn't seen such hectic activity since Prince Andrew brought loads of his champagne-swigging buddies back for some bacon and eggs back in June 1985.

Mr Sheen

We collared the team as they left Buck House and asked them just who exactly they thought they were.

Excuse me, YS team, but who exactly do you think you are? Erm, Members of the British Empire, actually. Okay, smarty-pants - what's the Queen's fave game? Well she likes games with a bit of royalty in them. Dizzy, Prince Of The

Yolk Folk was on her Speccy when we were there and she's already placed an order with Hamleys for a copy of Mega Twins. Did she give you any tea? Yeah, Earl Grey it was. Linda refused to drink it and James spat his all over the Axminster carpet. It was a tad embarrassing. Then Maryanne needed the loo so everybody decided that they had to go to the loo too. Except Linda. We all traipsed off through miles of corridors hung with tapestries and smelling of old books and Mr Sheen. When we got back, about an hour later, Linda was telling the Queen all about the last Heavenly gig she went to. Poor Queenie.

Did you meet the Queen Mum?

Yep, she came in for a quick cuppa. She sat on James' lap and asked him if he had any good tips for the 2.15 at Newmarket. He

told her to make sure she got rid of all the baddies before attempting to get into the lift on Level Two. I think it's safe to say that a good time was had by all. What are you going to do now? Conquer the world. Probably.

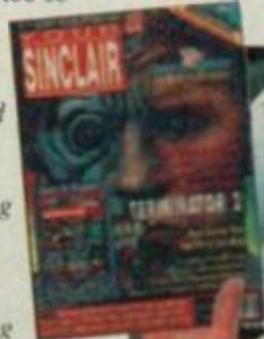

The Queen Mum showing off a copy of YS circa 1990. Copies are changing hands at vastly inflated prices.

THE QUEEN'S TOP TEN PEOPLE

1. Sir Jimmy Saville
2. Sir Harry Secombe
3. Dame Paul McCartney
4. Dame Judy Dench
5. Dame Edna Everage
6. Nikolai Ceaucescu
7. Bobby Geldof
8. Bobby Moore
9. Sir Freddie Laker
10. Donald Sinden, nearly

AT THE BUS-STOP WITH... Harry Cross

BUS STOP



Harry Cross - the grumpy old codge with a heart. But what we want to know is - what does he spend his money on?

Just the other day the YS team left the shed to get the bus home when who should they meet but Harry Cross out of Brookside. Quite frankly, they were shocked. What was Harry Cross doing at a bus-stop just a hundred yards from the Shed and, more importantly, why hadn't he popped in for a quick cuppa?

The team thought was a good chance to set the record straight on a number of issues.

YS: Tell us, Harry, you must be rolling in it what with all those TV appearances. You can obviously afford some pretty decent clobber, so why do you wear such appalling clothes?

Harry: Eh, I don't think that's any of your business. I can wear what I blimmin' well want, you young whippersnappers.

YS: Of course, Harry. Now, you're a chunky Northerner, is it really grim oop north?

Harry: Eh bay goom, when I were a lad it were reet grim. Nowadays there's Probe Records in Penny Lane and a few of those so-called pop groups, the young people seem to be having a good time. But, they know now't. All we had when I was young were George Formby and Gracie Fields. And God of course. Nowadays all the young 'uns are into The Farm. Load of crap, if you ask me.

YS: But is it grim?

Harry: Too blimmin' right. You soft lads know now't, livin' in your nice little bungalows with your nice little cheese plants. People like you make me sick. It's people like you who are responsible for the state of the world today.

YS: Actually, that's simply not true.

Harry: Akshully, I think you'll find it is. Look at you - do you work in t' factory? No, you blimmin' well don't. So there.

YS: Ah, here's our bus. So nice to have met you, Mr Cross. We must do it again sometime. Ta ta you old fart, you.



Eh, it's our Gracie. She were a grand lass, and she never forgot where she came from.

T-ZERS

♦ The Codies are bouncing into '92 with a, erm, very large bounce. To prove they're 100% behind the Speccy, those cheeky chaps a) have said that it's their favourite machine and b) are planning loads more Seymour releases.

First up should be *Seymour Takes The Wild West*. This will be an arcade adventure (what else?) in which Seymour bravely takes the Wild West but is forced to give it back later by his mum.

A new CJ the Elephant game will be out in the next few weeks as well. This will be another, um, arcade adventure.

Dizzy, that eggy favourite of many a Spectrum user won't be starring again until the Autumn by which time Europe will be united and Dizzy will have to be called L'oeuf qui marché or das Ei mit Hände or something.

Big Nose, a prehistoric caveman who's nothing to do with Little Nose who used to be on Blue Peter, is already famous on the Nintendo. His first game is reviewed in this issue. You'll be seeing more of him in 1992 along with Steg the slug. Yep, the Codies are on a roll.

♦ Brummie biggies US Gold are finally getting round to releasing *Indiana Jones And The Fate Of Atlantis*. We featured this in YS months ago, but it's only just about ready to be released now. Why? Well who knows why the software houses do things. It's a mystery.

♦ Thalamus, the software arm of Newsfield, are up and running once more. On the cards are the cute platformer *Creatures* (a huge hit on the Commodore 64) and *Armalyte*, a blaster of, er, blasting proportions. These have been delayed a fair bit, but we'll get them as soon as possible. Oh and while we're on the subject, why don't they show *The Dukes Of Hazzard* on telly anymore?



Aahgh! It's the horror of war in graphic detail. Sort of.



KARTOON KORNER KOMPO

If you're a cartoon fan, you'll probably be aware that Hi Tec have got the rather posh Hanna Barbera licence. They've been churning out Speccy versions of classics like Hong Kong Phooey, Ruff 'n' Reddy (whoever they are) and Top Cat.

And guess what? These are all available in one compilation. We've got ten copies of the *Hanna Barbera Cartoon Collection* to simply give away. And you (yes you!) can win one!

All you need to do is answer these three penetrating questions.

- What is the name of Yogi Bear's little sidekick?
- Which country does Hong Kong Phooey live in?
- What's the worst cartoon ever?

When you've decided on your answers, send 'em on a postcard (or stuck-down envelope) to us by 15th March. Address the cards to the "We hate Rocky And Bullwinkle", Compo, Your Sinclair, 29 Monmouth St Bath BA1 2BW.

Oh, and make sure we get them by the 15th of March, 1992.

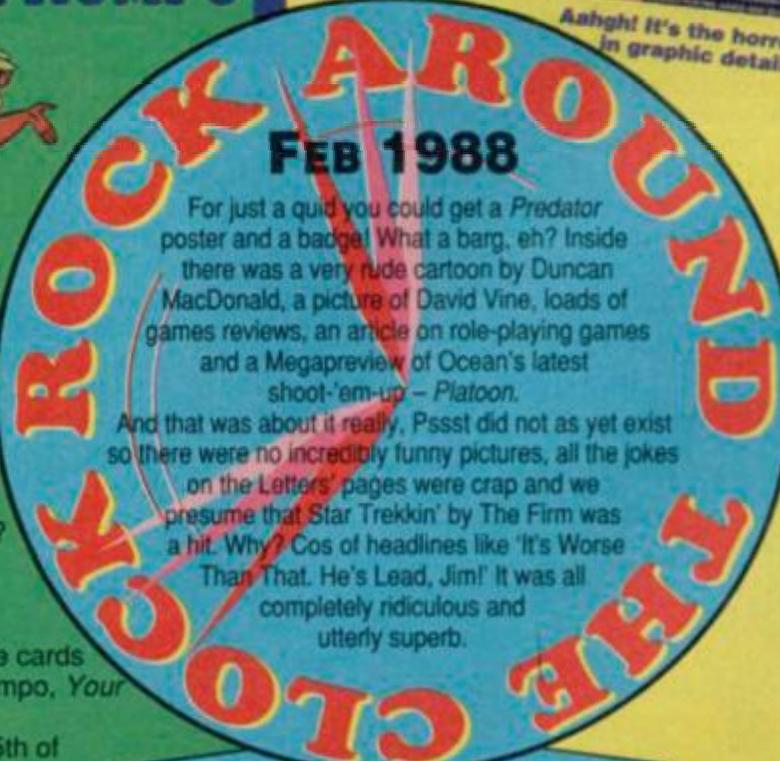

For just a quid you could get a *Predator* poster and a badge! What a bargain, eh? Inside there was a very rude cartoon by Duncan MacDonald, a picture of David Vine, loads of games reviews, an article on role-playing games and a Megapreview of Ocean's latest shoot-'em-up - *Platoon*.

And that was about it really. Pssst did not as yet exist so there were no incredibly funny pictures, all the jokes on the Letters' pages were crap and we presume that *Star Trekkin'* by The Firm was a hit. Why? Cos of headlines like 'It's Worse Than That. He's Lead, Jim!' It was all completely ridiculous and utterly superb.

US Gold/£10.99 cass £15.99 disk



JAMES I phoned up Yellow Pages yesterday, and they told me that G-LOC stands for G-force, Loss Of Consciousness. Fine. But what does all this nonsense actually mean? Well settle down at the back and I'll happily tell you.

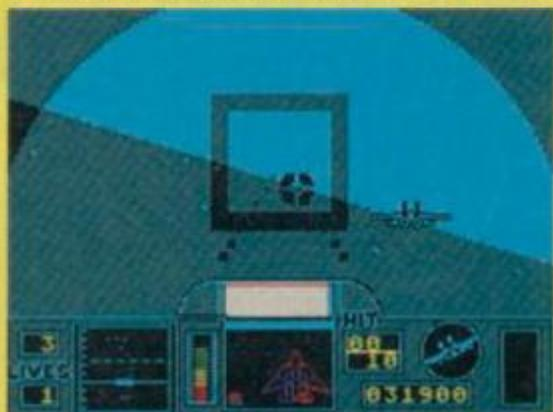

Achtung! Enemy swine ahead! Give him a taste of British steel, Carruthers! Wait until you see the whites of his foreign little eyes!

Modern fighter planes whizz around at such speeds that every time they go round even the smallest of corners, the blood rushes away from the pilot's head and to his feet. It might sound a lot of fun, but actually it doesn't do the pilot any good. Without blood, his brain goes a bit wonky and his eyes cease to work. He is then what we doctors call unconscious.

Flying a plane whilst you're unconscious is something only the foolhardy try, so in the air force, the pilots are taught to scream at the top of their voices when they start to black out. Screaming forces blood back into their heads and they don't pass out. It also frightens anyone in the vicinity to death. Clever, eh?

Now you can try it at home, kids. G-LOC has hit the Speccy, and hit it real hard. Taken from the rather amazing arcade game, it puts you in an F14 Tomcat (actually, in the blurb you get given at the beginning of the game, they don't call this plane an F14 Tomcat, but I know me aircraft, and I can tell you that it most certainly is an F14 Tomcat and let that be an end to the subject.) Anyway, this, er, plane you're flying is actually from an aircraft carrier somewhere in the Bermuda Triangle (or the Pacific or somewhere). The idea is simple. You take off, fly

around and destroy everything else in the sky, whilst trying to avoid the loss of consciousness bit.

There's bogies all over me!

Stop sniggering, cos bogies are what we fighter types call the enemy. As you chug along in your F14, your radar scope fills up with nasty little dots. These are bogies, so you've got to swing from left to right, blasting away with all weapons. More exciting than a trip to the Bourneville Factory!

You've got two sorts of weapons. Hold the fire button down for constant machine-guns, or press it quickly to release homing missiles. These are the best way of taking out enemies - but you only have a limited number and you need a red-lock on your scope before you're assured of a direct hit.

The battle is arranged into 36 waves. In the first wave you must destroy eight aircraft, then you must get ten, then 12 until you get to a ground attack phase which has oil-rigs and stuff to trash.

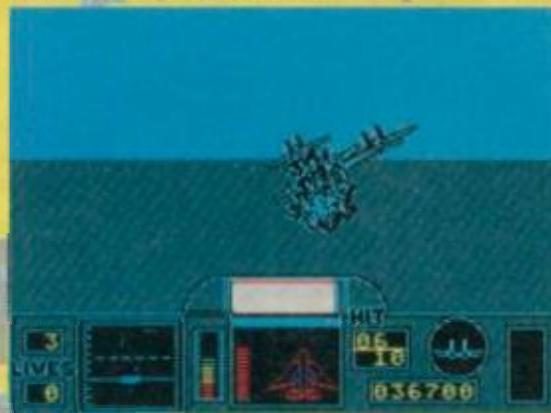

What a shot! They don't call me rooty-tooty-accurate-shooty James for nothing, you know. I've got six of the ten planes I need this level.

Although the game is in full 3D, with scrolling ground features and pretty accurate movement, it's not a flight sim as such. There's no taking off and landing, and you

can't turn around, climb or dive. You can do a lot of moving around though, which means you can aim your plane at the other fighters buzzing across your display in all directions.

Flight of the loonies

G-LOC is impressively fast. I must just say that. You get treated to a most pleasant view of your plane flying around, then you get dumped into the flying seat. Before you get a chance to



Fearsome combat-pilot James lines up on another pair of sitting ducks. He grits his teeth and clenches his bot as the enemies open fire. He closes in, targets and missile and foom! A good kill! The other plane banks round straight into the path of James's guns. Another kill!

take a deep breath, you're plunged right into the thick of the action. Planes come up from behind, they come from the front, the sides and er, every direction you can think of, with the possible exception of inside. You'll be overwhelmed. It reminded me a bit of that scene from Star Wars where you see about 60 fighters on screen all at once, blasting in all directions. (Well it did remind me of that!)

Luckily the screen update rate is fast enough to cope with this and make it pretty smooth as well. You can have about ten enemies on screen at any one time, which calls for salvos of missiles and your little fingers holding down the machine-guns as well. Phew, you'll say as you just about manage to get your quota of planes before your plane explodes and you see it from a nifty outside view as it tumbles into the sea. Sadly for you and your next of kin, it's impossible to eject from your knackered plane as it hurtles towards the cold, hard ground. Your only hope is to try and land your stricken plane on a bed factory. It's a slim chance, but you might make it because the part of the Pacc Ocean you're flying over has got loads of floating bed-factories sailing around.

Sound is a bit rudimentary. Clicking and hissing sounds for the machine-guns and the odd explosion are about all you can really expect. It doesn't matter - the graphics more than make up for it.

FIVE TOP GUN FACTS

- In order to train for the film, Tom Cruise actually had to fly a real F14. He nearly crashed it though and got a real telling off from the US Navy.
- Tommy actually suffered G-LOC during filming. He had to lie down in his tent for two days afterwards, saying he felt 'a bit tired'. What a big girl.
- An F14 costs as much as the entire London Underground System.
- But goes a great deal faster.
- Er, and uses more petrol.



Break hard right and stay on his tail. Then wait for a red-lock and fire. What could be simpler? (apart from sitting around and watching the telly).

JOYSTICK JUGGLERS

Mums, eh? Aren't they ace? Well, they are when they cook you nice meals and wash your clothes but not when all they can talk about is how you once vommed all over the vicar. We asked the jugglers to save us a journey and tell us exactly what they did when they were young.



Andy Hutchinson So what would your mother tell us if she was here now, Andy? "Probably that she couldn't let me

out of her sight for a minute in case I jumped out of the window. Y'see, up 'til I was about sixteen, I used to do it all the time. There was a hedge under my window and I worked out how to escape from my cot at a very early age! So what do you think this says about you? "Well, that I'm a bit of a rad and dangerous dude." Of course.

we thought we'd just ask her. Jon as a baby, eh? Tell us about it, mum. "Oh, he was a lovely baby. So round and pink, just like a little jelly. I remember taking him to the vicar's house for tea and he stuffed his little face full of French Fancies. Then the vicar picked him up and bounced little Jonty up and down on his knee for a bit. Oh, I was mortified." Why? "Well, all that bouncing up and down bounced those French Fancies right out of his little tum and into the vicar's lap." Ha! Ha!



Rich Pelley According to Rich, his entire life has been spent chasing babes. Unconvinced, we rang his mum to see

if our resident Romeo was being completely honest. So what's all this about the infant Rich and the girlies, Mrs Pelley? "Ha! Ha! He was terrified of them. Whenever they played kiss chase at school he'd come home crying his little eyes out cos some nasty girl had managed to catch him. Still, he seems to have got over it now." You can say that again.



Dave Golder Dave was a bit of a sleepy baby. "Once we were coming back from our hols and we landed at Gatwick, I

was so tired that I just kipped down in the nearest available comfy seat and shut my eyes. The next thing I knew, I was surrounded by strangers asking me who I was and where I came from. I'd climbed into the nearest car and ended up in a small hamlet near Plymouth." You got home alright though, didn't you? "I think so, when I next woke up I was in bed."



James Leach How would your mum embarrass you, James? "My mum really can't remember

much about me as a baby, so she'd probably just tell you that I ate beetles." What, real ones? "Of course. My favourite sort were ladybirds, they're a bit like M&Ms in that they've got a soft centre and a crisp shell. So they melt in your mouth, not in your hand." And how has this affected you in later life? "Erm, I quite like M&Ms." Fair enough.



Linda Barker And what horrible tales would your mum have to tell, little Linda? "None. I was a disgust-

ingly good baby who spent ages laughing at the sunshine. I was dead sweet, me. I had a really groovy anorak and these ace heart-shaped sunglasses and..." Oh dear.



Jon Pillar We called up Jon to ask him about his youth, but we got his mum instead. So

HIGH SCORES

90° - 100° The Queen hasn't come up with an award good enough for this game. It's better than an MBE and better than a knighthood. Yep, it's a Megagame alright!

80° - 89° A real stonker of a game, this one! A barg at twice the price!

70° - 79° A good, old, honest game. It's sort of like rice or pasta.

60° - 69° Here's where they start getting dodgy!

50° - 59° It'll probably start to annoy you after a while.

40° - 49° Enough niggles to really annoy you.

30° - 39° Worse than that Jason megamix. Pretty appalling.

20° - 29° Not worth getting out of bed for, let alone going to the shop.

10° - 19° Unprintable!

0° - 9° So bad that there's no word in the dictionary suitable.

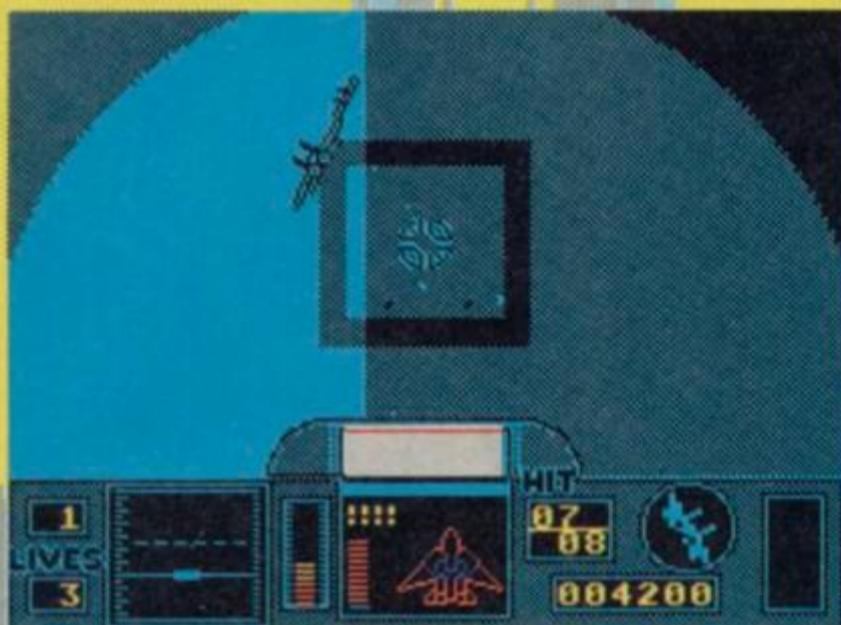

It's at times like these your brain is squashed down inside your skull and your eyes end up in your mouth. Gross, I know, but that's what it's like putting up with seriously high G-forces. So even Tom Cruise wouldn't look like Tom Cruise for long. He'd look like John Merrick.

So, with all this speed, the game is pretty difficult. As you play, you'll learn a technique. There are certain ways of dealing with planes which come in formations head on (it's usually hitting the M key for mega afterburner thrust), and there are manoeuvres you can do to get planes which attack



from each side. I'm not going to tell you those though. Let's just say that you have to turn harder than the other planes in order to keep your bullets landing fairly and squarely on them. Clever, eh? Hutch discovered early on, that one of the best ways of consistently beating the enemy planes was to waggle the joystick violently left and right while hammering away at the fire button. Personally, I used a bit more finesse and simply launched a bevy of missiles at each convoy. Horses for cannon fodder I guess.

G-LOC is a game you've got to play a lot before you get good enough to really start enjoy-

ing it and getting the high scores. It's addictive enough to keep you trying, though and if you're looking for a 3D blast 'em up, then look no further. Anyway, let's face it, all good things take absolutely woggles of practise. For instance Daniil Minogue wasn't born with the voice of a goddess, dear me know, she practised for years to sound like her big sister Kylie. However if your idea of sheer joy is to fly fast, fab jets then your quest is at an end and it looks as if you've found a personal Holy Grail which will enrich and rejuvenate your sad, shallow, games-playing life. Look, what I'm trying to say is that G-LOC is the game you should buy. I'm off for another go now. What ho chaps! ○

BLIM!

The biggest plane is a Russian six-jet job called the Mriya. This means Dream in Russian. The plane is the same size as the Isle Of Man.



5 GAME PACK CARTOON COLLECTION™



SPIKE IN TRANSYLVANIA
91%
ZZap Silver Medal

SLIGHTLY MAGIC
94%
YOUR SINCLAIR

Available on:
AMIGA & ST
£24.99
SPECTRUM, C64
AMSTRAD* £9.99

SEYMOUR GOES TO HOLLYWOOD
90%
YOUR SINCLAIR

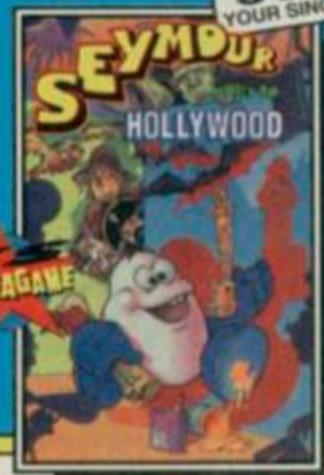
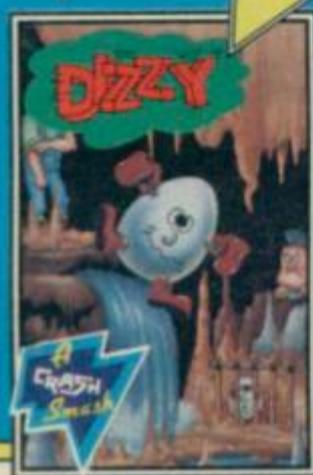

"A Crash Smash 90%"
The game that launched your favourite mega star.

"A glorious bounce around platform game packed with colour and playability"
ZZAP

"Graphics and presentation are excellent and all in all Slightly Magic is absolutely magic."
YOUR SINCLAIR

"Extremely accessible, refreshingly original in ideas and great staying power."
ZZAP

"Seymour is completely brilliant. It's packed with great graphics, it's got a kickin' sound track and it's very, very playable."
YOUR SINCLAIR

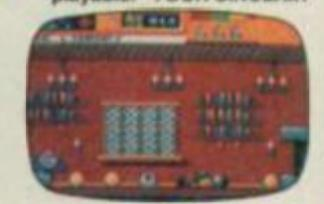

* Note Amstrad users have Little Puff substituted for CJ's Elephant Antics.



CODEMASTERS

AMIGA screen shots shown.

© Codemasters Software Company Limited 1991. PO Box 6, Leamington Spa, England, CV33 0SH

ATARI ST AND AMIGA
TREASURE ISLAND DIZZY 0898 555 092
LITTLE PUFF 0898 555 095
ROCKSTAR 0898 555 090
FANTASY WORLD DIZZY 0898 555 078
SEYMOUR IN HOLLYWOOD 0898 555 010
SPIKE IN TRANSYLVANIA 0898 555 105

HELP LINES
NEW RELEASE INFO LINE 0898 555 000 (Tells you what is being released this month)
If you can't get any further in any of these games and would like us to give hints & tips on how to solve all the puzzles just phone the numbers below. Please don't phone unless you are really stuck and make sure you get permission from the person who pays the phone bill first! Calls costs 36p per minute during off peak time and 48p per minute at all other times. (GREAT BRITAIN ONLY)

SPECTRUM, AMSTRAD, C64
DIZZY
TREASURE ISLAND DIZZY
FANTASY WORLD DIZZY
LITTLE PUFF
ROCKSTAR
MAGICLAND DIZZY
SLIGHTLY MAGIC
SEYMOUR IN HOLLYWOOD
SPIKE IN TRANSYLVANIA
0898 555 092
0898 555 095
0898 555 090
0898 555 078
0898 555 010
0898 555 105
0898 555 105

Wile-E-Coyote

Hi Tec/£3.99 cassette



LINDA Rolf Harris' Cartoon Time was one of the best shows ever to grace the nation's television sets. Instead of just watching cartoons run into one another, there was the added attraction of our Rolf warbling and drawing the aced doodles ever. In just three seconds he could get the very essence of Bugs Bunnyness onto paper.

Wile E Coyote and Road Runner were Rolf Harris staples and, as with most cartoons, we loved it cos it was violent. Wile E Coyote spends his entire life trying to catch Road Runner who, in turn, spends his time eluding the nasty canine and making him run into walls and fall off of cliffs. It obviously didn't hurt him, cos after a few seconds of star-gazing our Wile was up and running. In fact Wile was, like all those cartoon nasties, completely indestructible. No matter how many times Tom got knocked senseless by dustbin lids and broom-wielding maids, no matter how often Sylvester swings for Tweety-pie and slams into the window you know that they're going to live to face another day.



What on earth is going on here? Is it a sand-storm? Is it an earthquake? No, it's Wile E and Road Runner and a couple of wormy things.

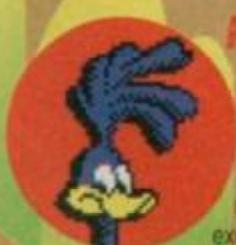

Happy bird-day

Unfortunately Hi Tec's *Road Runner And Wile E Coyote* hasn't got half the thrills of the original cartoon. You can't really do much to Wile E, except make him fall off of a cliff.

This is definitely the best bit of the game. As you hop just out of Wile E's reach, he goes tumbling down a massive abyss. Whooh!

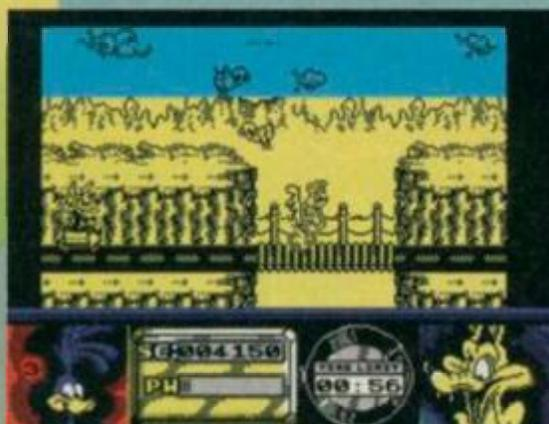

You're the bird running over the gorge and that's Wile coming up behind you. This bit's quite exciting, actually.



There are two levels, well there are eight actually but four of them are the pretty much the same and the other four are, erm, very similar. The first of these levels has you pecking away at little piles of birdseed, avoiding sandworms and bombs, collecting apples, banging into power-ups and, most importantly of all, avoiding Mr Coyote who whizzes about like a very whizzy thing indeed.

You're up against a clock, so all you've got to do is survive the level and peck up as much birdseed as you can. This comes in dead handy in the next level, so concentrate all your efforts on getting all the seed in, rather than going for the bonuses. My copy had a very strange bug on it which allowed old Road Runner to jump up to the top right-hand corner of the screen and sit pretty 'til the clock finished ticking away. As long as I didn't move, I was okay. As bugs go, it was pretty handy but none of the other copies around seem to be faulty. Ho hum, perhaps it was a special treat, just for little old me.

BLIM!

Coyotes are also known as cased wolves. This is cos when they make fur coats out of coyotes, the wearer's likely to look like a grey coffin.

The second part of the game sees you running along with Wile E in hot pursuit. Basically, you just have to keep on running, jump up now and then to grab an apple or jump over the various unidentifiable obstacles that are strewn across the path. This is where all that birdseed comes in handy, you should have built up enough energy to outrun Wile E. If you haven't, well - you're dead meat. (Well, 'til the next game anyway.) The next six levels are basically the same again, except the graphics change ever so slightly and it gets harder.

Wile we're at it...

The colour is pretty crappy throughout cos the blues and yellows are so muted. What's worse are the appalling graphics. They just sink into the background and refuse to stand up and be counted. I was sitting inches from the screen and I still couldn't make out what was going on. I ended up pecking worms instead of birdseed and jumping over apples rather than bombs. It's also pretty difficult, pop your head up and Wile E will come zooming over. Pow!

There are only two moves to master in *Road Runner And Wile E Coyote* and that's along and up. Apart from the fact that I found it quite difficult to see anything, there isn't really anything massively wrong with this game. Thing is, there isn't anything outstandingly good about it either. It's just a plain run along and collect-'em-up.



Wile E's on a rocket, so keep your head down Road Runner! If you look closely at the grey bit, you might be able to see a worm. Jump!



I was disappointed, I expected a bit more from the Looney Tunes' licence. I'm not asking for much, but I'd like to be able to tell the difference between a worm and a pile of birdseed. Cherryade and a pair of bison are much more fun. (Bear up, bison!)

FAST THINGS THAT I HAVE KNOWN



Pot Noodles - probably one of this century's greatest inventions. They take about four minutes and contain plenty of nutritious value and only a few calories.



Porsche - I've never actually met a Porsche but I've heard that they're really fast.



Bankrobbers - probably the fastest non-athletes in the world. If these chaps

formed an olympic running team they'd thrash Daley Thompson, Steve Cram and Ben Jonson - all in one go.



Noses - can be as fast as bankrobbers if you catch them in the right mood.



Sweetcorn - it goes straight through you.

FINAL VERDICT

LIFE EXPECTANCY	67°	ADDICTIVENESS	65°
GRAPHICS	40°	INSTANT APPEAL	68°

DIAGNOSIS
Samey and disappointing collect-'em-up with extremely obscure graphics.

68°

ESR CISCO

Mirrorsoft/£9.99 cass £x.xx disk



Every year the centre of San Francisco gets cordoned off in preparation for the race of races. It seems that San Francisco is a dream city for people who like to drive around in car chases all the time, and the cops have a hard time keeping up with them all. So each year they close off the city centre and race each other just to prove how crap they are.

And hey presto! That's the scene set. Pretty simple stuff, isn't it? Well anyway, the result of all this is that you've got a racing game in 3D, which might or might not be like every other racing game on the Speccy. Let's have a look at it or, as they say in San Francisco, let's have a look at it, man.

You start off in a typical cop-car. You know the sort, the blue and white four door with a massive bonnet and boot, or hood and trunk as our Californian cousins might perhaps say. If you're still unsure as to what sort of a car this is, just think back to the sort of police vehicles you used to see in *The Dukes Of Hazard*; incidentally, they certainly should put back into its old slot of tea-time on Saturdays.

The car has two gears, high and low. In low it'll do around 100 mph, but when you slam it into high gear this will whizz up to a rather spanky 175 mph which is probably much faster than they can go in real life.

Do you go on the bridge?

Yes, well the game actually starts on the Golden Gate Bridge. You are close to the front of a pack of about ten other coppers, all in cars which look identical to yours, but are blue, whereas yours is a rather fetching shade of red.

At the top of the screen there are the usual Formula One lights, three red and one green. When the green

one appears, you hit the gas-pedal. And everybody screeches past you. It's immensely annoying because you instantly lose your first place, even though you're accelerating as quickly as your car will go.

Mirrorsoft must have done this deliberately because you get so angry that you concentrate on winning; which is, after all, the idea of the game. So as most of the cars burn off up the road, you've got to knuckle down to some serious work.

First thing to do is suss out the gears. Although there are only two, it's a wee bit tricky changing between them.

What you've got to do is pull back on the joystick and hit fire at exactly the same time. You'll lose a bit of speed as you pull the joystick back, but with any luck you'll now be in the gear of your choice.

At 175mph it's pretty easy to start gaining back the places so long as the road is straight and the cars stay in their lanes. The problems start with the corners, hills and dangerous driving of the other coppers belting along in their panda cars.

Collision detection is a bit generous, shall we say. What seems to happen is that you can drive through other people, but your speed decreases to about 40mph. I wish that would happen in real life, but in the game it takes some getting used to.

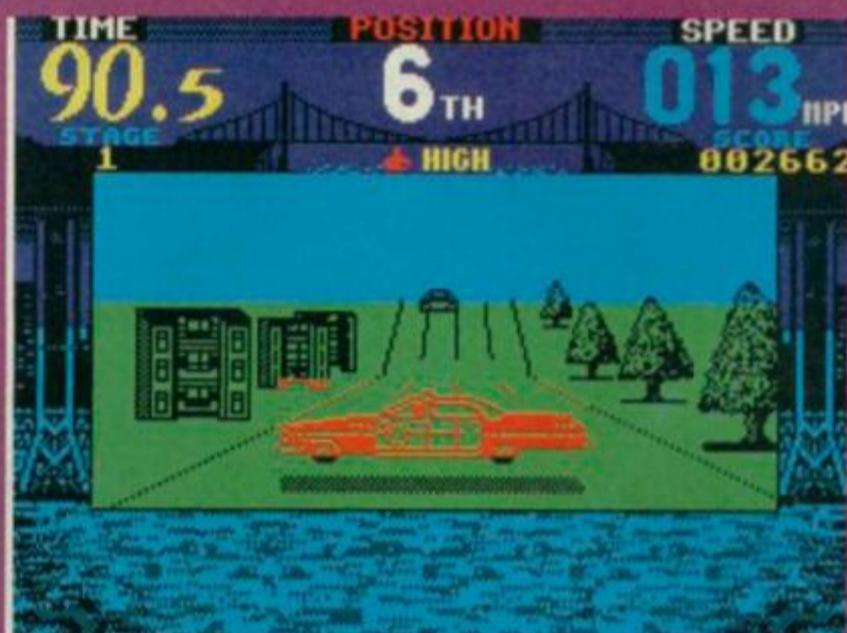

Driving in a straight line is for wimps. If you can spin your car around like a waltzer and still qualify, you'll be a man my son. *Cisco Heat* is certainly one way of making that difficult but necessary transition from childhood to maturity without involving all your relatives.

The Streets Of San Francisco

All would be fine, dandy, and rather boring were it not for the corners and hills that make Frisco an interesting city rather than a corner-less, hill-less one.

The sides of the road are littered with all sorts of things like trees, bill-boards and telegraph poles. Hit them and one of two things could happen; you could spin the car round, losing large amounts of speed but keeping basically on the road. Or you could flip the car right upside down. This knackers your speed completely and will

5 FACTS ABOUT SAN FRANCISCO (AND HEAT)

- San Francisco will be completely pedestrianised by 1993. So there'll be no more car chases, *Streets Of San Francisco* or cop races.
- In 'Frisco in summer it approaches 130° F in the shade. So there's lots of heat there.
- There are so many hills there, it's impossible to play marbles anywhere. Instead, everybody has car chases (but what they'll be up to after 1993 is anyone's guess).
- Dirty Harry was filmed there. So was *Blake's 7* and the *Multi-Coloured Swap Shop*.
- There's a bridge there, made completely of gold (with a gate built into it).

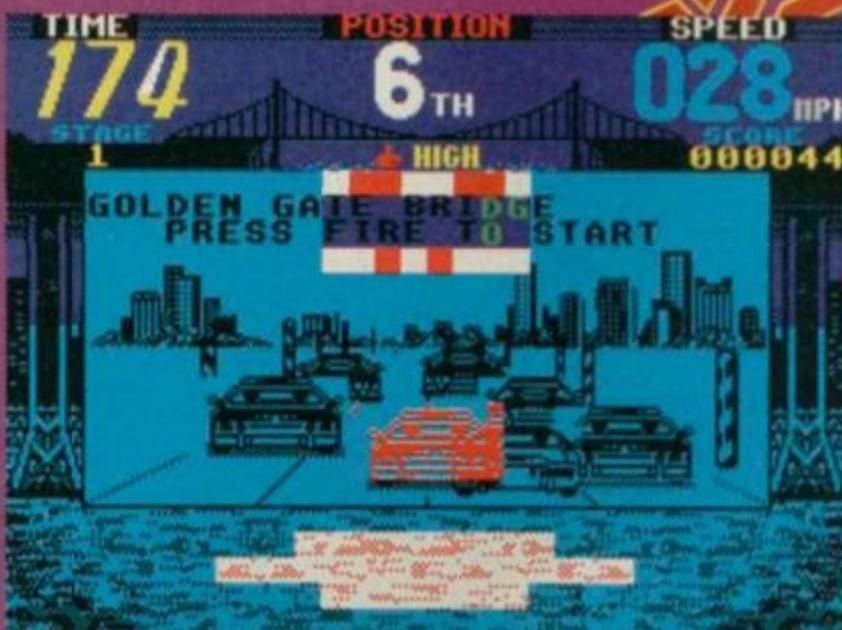

The start of the race is more confusing than simultaneous equations. You've got keep your eyes fixed on one path, ignore it completely and go all over the roads. If there are bods in the middle of the road, hit the horn and they'll move out of the way as if by magic.

HEAT



It's not fair when this happens. You've only got one corner to go round and the blimmin' time runs out! It makes you want to pull out the Specky wires, jump on the Specky and then get on quietly with your homework until tea-time and your mum calls you for toasted muffins.

almost certainly ruin your entire life. Well, as far as this attempt on the game is concerned anyway.

The race is divided into stages, and a large clock ticks away in the top left of the screen. If you get through the first stage, from the Golden Gate Bridge to Fisherman's Wharf, you get a whole chunk of extra time to blast your way further on towards the finish line.

Obviously, the stages get tougher as you get further into the game, with the added bummer that if you go really fast and build up a bank of spare time, it doesn't

just possible to squeeze through on one side or the other, but if you fail, you'll be catapulted high into the air and, although you'll survive, you'll lose loads of speed and time.

Mirrorsoft have remained true to the Jaleco coin-op, and have put in some wicked intersection corners. What you're supposed to do is look out for the sign-posts at each intersection. If there aren't any you can whizz straight

carry through onto the next stage. So each time you've just got to go like the wind, mama!

As well as the other cars, there's plenty of traffic which will happily get in your way. Obviously the police haven't done a very good job of cordoning off the centre of the city, because there are loads of cars, trucks and buses littering the roads.

These often occur at intersections, where the offending vehicle will straddle the road completely. How you get round it is up to you. It's

Well there is a way of doing it. If you whack the gears into low just as you approach the junction, the speed slams off and you are just able to squeal round the corner. But it's dead difficult and you'll be lucky if you don't have a little argument with the kerb.

Polite police please

Another weird feature which has been brought in from the coin-op is the horn. Pressing fire (or the space bar) beeps your horn, and, because you're driving against pretty law-abiding policemen, they move out of the way. It's a bit ridiculous to try and overtake somebody who's doing their best to block you, then beep your horn and watch the silly fool pull over and let you howl past.

Hmm. I think I've given you a pretty good idea of what's actually happening in Cisco Heat. But what I haven't said is what it's like to play.

Here's the bad news. Cisco Heat isn't really much cop (nice gag, that). It's a mono job, with a rather poor backdrop of a pretty unrecognisable cityscape. The road isn't solidly filled in or anything. It's just a load of flickering straight lines which scroll past with astonishing jerkiness.

This is the game's major problem. The frames chug past so slowly you've got time to see each one and notice how not-very-good it is. I've got the strong feeling that if everything was really quick, the graphics would look much better.

The jerkiness actually affects your gameplay, too. It makes the car unresponsive, so you have to move earlier than you need. This means that as well as fighting the twisty roads and the other road-users, you've actually got to make allowances for poor programming.

Cisco Heat has got lots of stages, and if you really concentrate on the flickery screen, it is possible to get quite far into it.

However, it just doesn't have the whizzy graphics or impression of speed that it needs. It's good, but it's not as completely brilliant as I expected it to be. You'd be better off with Power Drift on budget. ☹



across (avoiding any buses, trams or stranded cars). If there is a sign-post, you've got to wait until you can read it, then swerve violently in the direction it's pointing.

The bad news is that the intersections, like all intersections in the USA, are at right angles. So what you're being asked to do is go round a right angle bend at 175 mph. A tad tricky, don't you think?

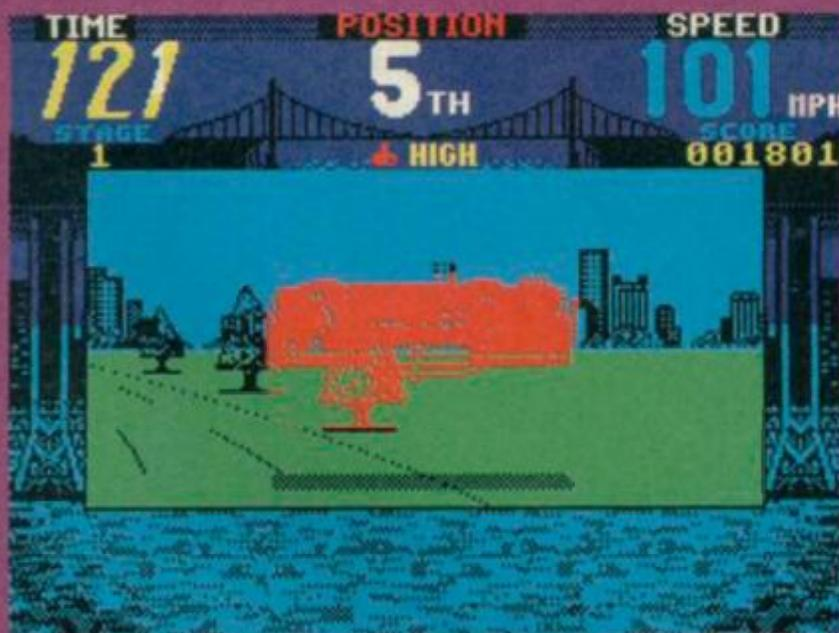

Oops! If you let your tyres scuff the kerb you might end up seeing the world from a slightly different viewpoint (ie upside down and with your head caved in). So if you've always wanted to smash up cop cars like they did in the brilliant 'Dukes Of Hazzard' show, you can. Hurrah.

FINAL VERDICT			
LIFE EXPECTANCY	67°	ADDICTIVENESS	61°
GRAPHICS	68°	INSTANT APPEAL	60°
DIAGNOSIS			
Cisco Heat doesn't take racing games places they've never been. It's not very good, really.			

Moontorc

Atlantis/£3.99 cass



I like to think that the Moontorc in question is a necklace made of moonbeams that have been wrung from the moon like soapy water from a dishcloth. (Why? Ed) Well, cos it's sort of grittily poetic. Unfortunately, the Moontorc in question is simply an amulet of magical and mysterious properties. Actually, I suppose it could be made out of galactic particles, it doesn't say that it isn't.

Moontorc, the game rather than the thing, is a flip-screen shoot and collect-'em-up. There are four levels to roam through and they're of the

BLIM!

The moon is, in fact, a natural satellite. Unlike most satellites it is not made of metal, it actually has a major iron deficiency. That's why it hasn't got any of those funny aluminium spiky things sticking out of it.



Pretty, isn't it? The four levels are shown on the right and all the characters on the left. What about that Princess Lalena, eh? Phwoarr!



Here I am at ye olde shoppe. Two pints of milk, ten spells, a piece of Moontorc and a quarter of your finest lemon sherberts.

weirdly colourful sort. You're a little chap and you've got to rescue the truly wondrous Princess Lalena from the blistered hands of the truly smelly Dark Lord. Cos you're such a nice sort of guy you're obviously not used to being nasty. So you're going to need a bit of help.

The idea is to collect gold and keys and parts of the Moontorc so you can progress and say hi to your babe. Along the way there are plenty of shops to pop into and do the odd bit of purchasing. You won't actually be able to get very far in to the game without paying a visit to one of these shops as they sell everything you're likely to need along the way. There are spells to blast the baddies away with, weapons to do something pretty similar and keys to open doors that let you into other parts of the game. Oh, and you can pick up parts of the Moontorc. Once you've managed to survive long enough to collect a complete Moontorc you can go onto the next level.

Mushroom man

The graphics are very Dizzy-like; there are multi-coloured mushrooms to jump around on, plenty of little platforms and nicely detailed shops. Best of all, when you kill someone loads of little hearts replace the dead blokie. I thought it was all dead sweet, but sweetness doth not an excellent game make, as



"Wish they would let me in, so I could find out what's behind the green door." I'll have to get that green key first though.

my Uncle Johnny who used to be a pop star once said.

The plot's fine and the graphics are beautiful - so why isn't it the best game in the universe? Well, your little chap isn't very well animated and he's not very good at moving. Just when you think you're about to land in a stream of molten acid, you step off a mushroom into mid-air. Then, when it's patently obvious that the space between you and the ledge is small enough for a mole to jump, you land in the acid stream and... poom!

If you hate flip-screeners then this is obviously not the game for you. It's easy to see why they're so hated. Jumping off a platform and finding yourself face-to-face with a two-headed greed monster from hell isn't perhaps the best way to enjoy a game. Still, it's a nice enough gamette and one that should keep you occupied in that annoying space between the end of Neighbours and dinner time. ◊



3D STOCK CARS 2

Challenge Software/£3.99 cass



What a particularly stupid sport stock car racing is. I mean, you spend about six months getting a car ready to be raced and then five minutes smashing it into other cars, walls, bystanders and areas of outstanding natural beauty. In fact, I think that it should be banned forthwith. If not sooner!

Anyway, who's played the SuperSprint game on the covertape? Right, well you lot should have a pretty good idea what this budge is all about. You see, 3D Stock Cars 2 is about racing around a series of circuits against three other cars. The only major differences between this game and SS are: a) you have to qualify before each race, b) the cars look like egg-boxes, c) you can design your own 'championship' and d) this game's crap.

The blurb on the tape inlay suggests that you can create your own championship. What this entails is choosing the order of the tracks and the number of

laps you complete in each race. Not exactly gripping stuff! Nope I'm sorry 3D Stock Cars 2 is awful; the control method's dodgy, the cars look more like space invaders, the game's extremely evocative of SS and it gets terribly boring after ten minutes. Hurumph! ◊

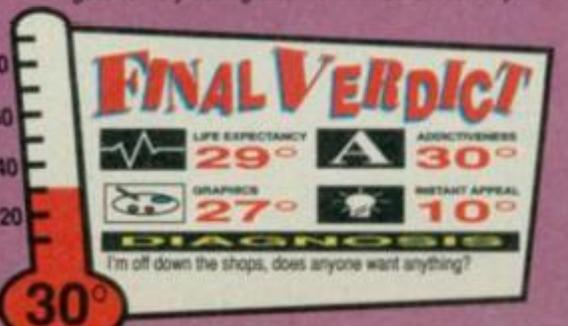

The polluter and profiteer
Sly Sludge™



The degenerate and toxic
Verminous Skumm™



CAPTAIN PLANET

AND THE PLANETEERS™



Oil spills. Air pollution.
Endangered animals. The
award-winning TV show Captain
Planet & The Planeteers has
turned saving the Earth's
environment into the ultimate
adventure.

And now, it's your turn to go up
against the most dangerous
enemies our environment has
ever faced - Looten Plunder, Duke
Nukem, Hoggish Greedly,
Dr Blight and more.

The forces of Earth, Fire, Wind,
Water and Heart are yours. Put
them together and become
Captain Planet. Your Eco-copter is
waiting.

THE POWER
IS YOURS



Coming soon
for your computer
Also available on video



MINDSCAPE

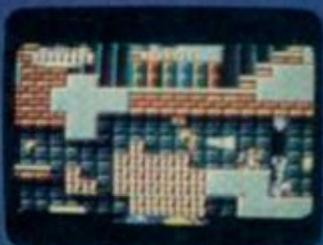

INTERNATIONAL SPEEDWAY

aaaaCodemasters/£3.99 cass



When I was a wee nipper, ooh, fewer years ago than I care to remember, I used to go to the Eastville Speedway circuit in Bristol every Wednesday night to watch the racing.

I often came away disappointed because the Speedway was only on Friday nights. But just seeing the track was enough - I became a fan for life.

And now the thrill of the dirt, the smell of the crowd and the noise of the hot-dogs has been recreated by the Codies in this budgetgie. Tremblingly, I loaded it up...

When you start to play, you've got to type in your name. Fair enough, but you must also type in your nationality. Er, okay. You must also type in your continent. Oh, good grief! Once you've done that, though, it's time to a race. This is where things get even more exciting than they were before. That is as long as you thought they were exciting before.

You race three other guys, and you view a 3D display of the track in the top half of the screen. The bottom half is taken up with a picture of your purple helmet and a top-view of the oblong-ish circuit.



On this map there are four large blobs. These are the

racers, so it's easy to see where everybody else is if you can't actually view them in the 3D action-packed screen above.

Racing around the circuit is pretty simple in theory. You just twist open the throttle and hope for the best. When a corner comes up, you ease off on the speed a bit and swing the bike's botty out as fast as you can. It's all done using only two keys, or directions on the joystick, if you will.

The idea is to keep on the racing line all the way round. Not only does this keep your speed up, it also stops the other dudes whizzing past (but they'll have a go anyway). One of the other guys is as fast as you, the other two are a bit slower. So if you do everything right, you should be able to beat them all. But this is where the problems start.

I don't know about the copies on the streets, but ours in the Shed had a bit of a dodgy control system. It accelerated, seemed to slow down, went left a bit then decided to go straight for a while, took out a mortgage and set up a cosy cottage near Newmarket with its wife and children. Strange, eh?

This apart, *International Speedway* is rather quick, smooth and playable. It's repetitive though, with just the one circuit to whizz round. I suppose that this shouldn't be too much of a surprise cos the real thing is exactly the same. If you're a great fan, which I've just decided I'm not, you might want to get hold of this. Before you do, here's a quick warning - it's just a bit boring. ☹



Oh yes, Mrs Higginbotham! I'd love another helping of cranberry tart!

Come back!
Come back!
The man
hasn't said
'go' yet!



Hmm. The outside of the circuit doesn't seem to be the best place for overtaking. In fact, it's positively useless. We live and learn eh, readers.



JIMMY'S SUPER LEAGUE

Beyond Belief/£3.99 cass



So there were these two nuns, and one says to the other, "Do you believe in life insurance?" And the other one says...oh, sorry, have we started doing the review now? Erm, I'll tell you the rest of the joke later, Hutch.

Apologies for that, readers. You joined us a little early. Anyway (sounds of paper shuffling), let's get on. *Jimmy's Super League*, yes indeed. This is another management sim from the Beyond Belief stable. In fact it was programmed behind that pile of dimly-lit straw next to the horse feed.

You've got a team of eleven strapping young feller-me-lads raring to go and play a tough game of ninety minutes, two halves and a spell in the sin bin.



This is perhaps one of the saddest offices I've ever seen. I'd rather work in a mortuary than have to look at those green walls. Urgh!

Everything is controlled from a main office with a PC on the desk, a phone and a filing cabinet. You simply move the cursor onto the telephone or computer or whatever and you can go for a quick training session with the lads, play the game, look at very long lists of names and numbers and so on. There's masses of highly exciting detail on each bod, even down to what they had for breakfast. This is actually very important to a player's mental and physical agility, and can mean the difference between them being sick on the pitch or not.

League Facts

- ★ A league is actually 3,456 miles.
- ★ A league is something plumbers come to fix.
- ★ The Human League was a crap New Wave band.

All this detail is fine and groovy, and it adds a lot of atmosphere to a pretty boring game. But this doesn't hide the fact that it's still just an okayish footie management sim, and all you really need to do is select eleven players. Amongst the list of names you'll find that of the internationally famous W Scribo - art critic, deep sea diver, wok assembler and part-time pipe cleaner. Where would Beyond Belief be without him, eh?

The best bit is the game itself. You get both a commentary and an edited goal-mouth graphical action sequence. A David Coleman-type chap sits and watches each game carefully, making suitable comments in a scroily line box, like "Nobel prizewinner W Scribo has the ball. He passes to W

Scribo, famous author, who gets into position and shoots. But it's a great save by the Scribo twins (both minor Norse gods, of course) in goal!"

A side-on view of the goal shows some enterprising dude rushing on (it's usually our fave, Sir W of Scribo MBE) to have a shot. You can watch with bated breath as he whacks the ball at the net. If the goalie is alert, he can get in the way, otherwise it's a classic goal of the sort which will crop up on A Question Of Sport in years to come.

What *Super League* lacks, of course, is an action packed 90 minutes of full-screen on-pitch action. The only way you can get an idea of what's going on is to read what the commentator is saying. It's like an extremely weird cross between listening to the radio and watching the telly.

The only other fault of *Super League* is that it's as slow as almost every other management sim. You keep wondering whether your Spiccoy has crashed.

I know that the computer is actually making lots of lovely calculations while you're watching a blank screen, but couldn't they display a little animation or show us the latest stock and share prices or something? Even Ceelax would be more interesting than a screen with the words 'Please Wait' on them.

So, in conclusion, *Jimmy's Super League* is proof that management sims are getting better. Most people still prefer a shoot-'em-up, but marnie sims (as they're known in the biz) have reached new heights, it would seem. ☺



PAPERBOY 2

Mindscape
£15.99 Disk/£10.99 Cass



HUTCH How many of you lovely peeps have, or used to have, a paper-round? Hmm, so it would appear that approximately 50 percent of the population has been completely and utterly ripped off by newsagents who pay an absolutely pathetic wage to gullible kids and any other down and out unfortunates who find themselves suddenly in need of dosh. I mean come on, you get up at about five o'clock in the morning, rain or shine and proceed to spend about an hour and a half shoving weighty scandal-sheets through tiny letter-boxes for about 50p a day. Daylight robbery! Paper-people throw off your shackles and play this game instead. (You weren't ever a paperboy were you, Hutch? Linda.)

Yes, but that doesn't mean I'm bitter or anything. Anyway, what we have here is the follow-up to that ever-so-successful gamette

Paperboy. In this revised version there's now a lovely red and yellow two on the box and ermm, some other tweaks to the gameplay.

Tweaks?

You know the kind of thing. Spiced up graphics, improved sound, greater options; tweaks. In *Paperboy 2*, the main difference is largely cosmetic. You see, instead of just scrolling up the screen at an odd angle from bottom left to top right, *Paperboy 2* scrolls from the bottom right to the top left as well. What this means is that instead of just delivering papers to one side of a street, you've got to cover both sides.

The idea of the game is to lob newspapers into peo-

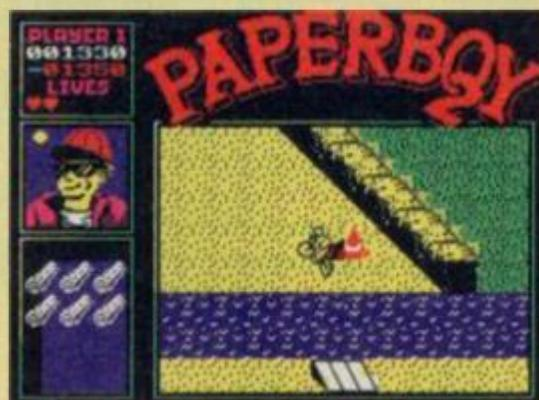

My word, there's one of the police's new deterrent traffic cones. It's the size of a small house and thus completely indestructible.

ple's mailboxes. Get your timing wrong and the newspaper will smash a window, knock down a trash can, ruin a picket fence or even knock down a gravestone. If you're too generous with the newspapers, then for every stray object which you hit, you'll lose a certain amount of points. If you miss a house on your rounds, then they'll cancel their subscription. When everyone's cancelled, you're fired and it's time to put the bike back in the shed.

It might sound easy, but believe me it isn't. There are all sorts of suburban horrors waiting to knock you off your bike; kids in go-karts, men carrying pianos, trucks and cannonballs (no, really!) are just waiting to wipe that Golden Grahams smirk off your face.

Doesn't sound too thrilling

Ah, yes. However, once you get terribly good at *Paperboy 2*, you can start having some real fun. For instance, in this particular cul-de-sac of suburbia there are jumps all over the place. Thus you can pedal like mad right across someone's front garden and perform a neat jump right over the fence into next door's prize purple begonias.

What's more, if you actually manage to survive both sides of a street, you get to attempt the assault course.

This has got loads of bales of hay, targets and water jumps. However, if you make so much as one teensy-weensy mistake you finish the ride and don't get any bonus points.

Once your end of day score has been calculated, you can head off home to bed, lay your head down on the pillow and get some serious zzz's in. You see, you'll need a straight head for tomorrow's exertions when you'll do exactly the same with more obstacles in the way and more houses to deliver to.

It's all a tremendous giggle. The graphics are groovy and there's very little colour clash. Your paperboy scrolls around pretty darned smoothly, even though a close-up of his crashes

BLIM!

An American once pulled a wheelie for four hours 21 minutes. However not one girl was impressed and he promptly went to the cinema alone.

would have been nice. Sound's a tad mediocre, but then how do you make a paper round sound sound? There are two problems with this game. Firstly the collision detection's absolutely crap. You can be peddling along nowhere near a hedge or anything and the game will suddenly decide you're doing far too well and stick a large stick into your front wheel's spokes.

Secondly, it's not that different to the original *Paperboy*. In fact, about the only substantial changes are that you can choose what sex your paper-person is and you also get to deliver to both sides of the street! Vehicles still emerge from side streets like they did in the original and kids still attack you on the pavements with go-karts. The odd new hazard has been bunged in for good effect. For instance a runaway horse comes belting out of a wood at one point and there's a house which dislikes you so much they lob cannonballs at you. *Paperboy 2*'s a groovesome game, but it's more like *Paperboy 1.3*.

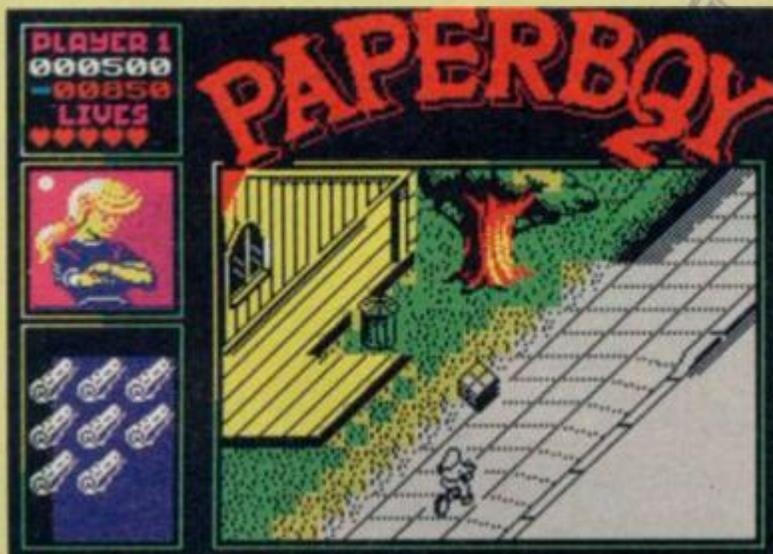

Some inconsiderate poo-head's gone and left a huge Rubik cube right in the middle of the path. Just as well I'm a foxy-chick and thus a much quicker-thinker than your average paper-person!

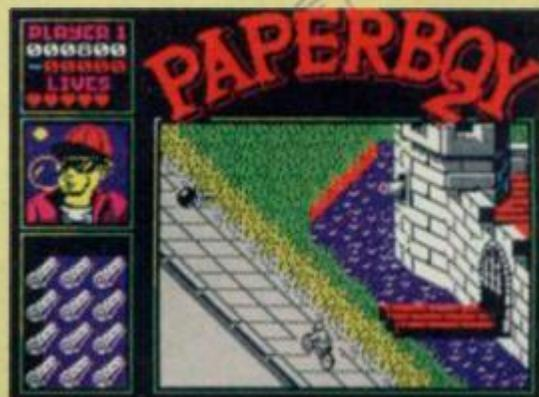

While out on his paper-round, our intrepid paperboy encounters a randy space-hopper with rabies. The youth today, eh?



2-HOT 2-HANDLE

THE SPECIAL PACK OF ACTION GAMES THAT WILL CAUSE A

Riot!

2-HOT

2-Handle



AMIGA ATARI ST

ocean

AMSTRAD
SPECTRUM
COMMODORE

Letters



WRITE TO THE ED, YS, 30 MONMOUTH STREET, BATH BA1 2BW
 Star Letter winners receive three free games! All letters win a YS badge!

I'm feeling a bit down this month, Spec-chums. I'll be okay in a bit, I just hate the first couple of weeks after Christmas. It's cold, it's dark and there are no pressies to look forward to. Still, it gives me a chance to polish my skateboard and darn my rad clobber. Come the spring I'll be ready to roll with the best of them. Yep, I'll turn into a beautiful butterfly, flying off kerbs and swooping up hills... Well, I can dream, can't I?

Outside the Shed it looks like snow, inside it looks a mess. Never mind, Linda can tidy it up and I can answer your letters. On with the show...

MARVYOUS

I would have written this sooner, but every time I pick up a pen I feel faint cos it reminds me of work and I have to lie down. I was writing to tell you that I think YS is rad and très outré, marvy and hip. It also makes me feel young again and I was hoping that you'd give me a job.

Now, tell me if I'm mad but Daath is where dreams are formulated and where the hidden thoughts lie. It's got a real world twin and it's

certainly not an easy way out, but it is chaotic. So get lost in a tree.

You should listen to Crass, they're heavy.

Laz Taylor
 Crouch End, London

Marvy, eh? I like it. It's a shame that you're obviously completely off your rocker. If you really want a job here you've gone about it the wrong way. You've flattered us, which is a good start, but it's all downhill from there.

I mean, what is all this nonsense about Daath? I'll tell you what it is - a load of juggling balls. Next you'll be telling me that the Confucian theory of dualism is a really rad philosophy. (Actually, the whole idea of everything having an opposite and... Linda) Shut up, Linda. As for Crass, give us a break. It's bad enough having to Andy O's punk nonsense without the threat of some smelly anarchist band. You can't have a job. Basically. Ed.

TRUTH WILL OUT

Ha! Ha! Let the truth be told at last. For I have uncovered your dastardly secret hitherto unknown to the general public. I will shower you with facts and figures to prove that you, Mr Hutchinson, are no less than a Timelord on a strange secret mission...

● Fact - The constant change of

appearance and personality.

● Fact - Your odd outward appearance and strange beliefs.

● Fact - The Shed in which a coachload of people work is a Tardis-like building. Large on the inside yet small on the outside. Damning evidence, eh?

BB
 Bromley, Kent

Damn! I thought I'd disguised myself so well, too. My cunning disguise as a skateboarding, EMF freak is obviously not as good as I thought it was. Tom Baker wore a ridiculously long scarf and got away with it. Pih.

Actually, I don't think you've got your facts very well sorted at all. Fact one - I haven't changed my appearance at all, I've always worn T-shirts and baseball caps and I probably always will. As for these supposed personality changes - humbug.

Fact two - my outward appearance isn't odd at all. I have two legs, two arms, a nose, a mouth and all the other things that human beings generally have. As for the clothes, they aren't in the slightest bit odd. And neither are my beliefs.

Fact three - you've got me there. The Shed is small yet it contains so much. In fact, maybe you're right, maybe I am odd. Oh dear, that twelfth finger wasn't there before. And while we're on the subject, how come nobody else is wearing a wig? Ed.

AN ELDERLY CHAP WRITES

I would just like to inform you that all your readers are not as young as your readers believe. (Sorry? Ed) Well, I don't believe it anyway. Judging by your Letters pages you must have some very intelligent and witty youngsters, or some that are not as young as they make out. (Young people can be quite intelligent and witty, actually. Ed)

I have been a reader of YS for a few years now and I don't mind admitting that I'm in my late twenties.

I know I'm not the oldest reader as my mother has been a YS reader for longer than me. I won't tell you her age, but I will tell you that I have a sister who is eight years older

DOODLEBUGS

Toilet humour, eh? You can't beat it. I don't really understand sophisticated humour, Linda's jokes always go way over my head, so John Copley's Fart Simpson was

just my style. On a more mature note, there's Stack Up and Switchblade by, erm, somebody who wishes to remain nameless. Can't say I blame him really.



than me. Come on the older generation, admit it – it's not childish to play computer games and read YS. It's enjoyable.

J Foster
Hull

I'm sorry to have to inform you that you are not old. In fact, you're probably only a few years older than me and I'm not at all wrinkled. It's my belief that you're as young as you feel, and I think that your letter just goes to show what a strange society we live in. Around the age of 22 people start to think they're getting old, I know this for a fact cos I see it happening everyday. (No names mentioned.)

'J', you've got years and years ahead of you so stop feeling sorry for yourself and get sorted. Even if your mum's 79, which is quite unlikely, she's not as old as our next reader. Come in, Mrs Turner. Ed.

OOH, YOU YOUNGSTERS!

With reference to page eight of your October issue, you seem to think that you youngsters have the monopoly. I'd like to reply to the points made in Pssst.

KINDLY LEAVE



THE STAGE

Jokes, eh? They're very hard to come by in these sad and dim January days. Through the darkness shines a tiny light, it's the wit of **Barry Lee Thomas** of

Tonbridge in Kent...

Q: What's green and goes up and down?
A: A green yo-yo
And...

Q: What's more dangerous than a four second egg?
A: A three second egg.
And here's another...

Q: What's black, white, black, white, black, white?
A: A penguin rolling down a hill.
And finally

Q: What's black and white and laughs?
A: The penguin that pushed the other penguin down the hill.
Well, they were a darn sight better than any of the others you lot bothered to send in.

1. We pay half fare and have it ready.
2. Not everyone has diphtheria though I still make cakes.
3. We don't all slam doors.
4. Coats? Maybe.
5. And some of us do read your magazine. Mind you, it's often difficult for ancient eyes to read small print on green paper. Still, we do enjoy most of the games. Not bad at 80, eh?

Mrs Turner
Brighton, East Sussex

What is it with age this month? I got so many letters from people claiming that old people are really ace. You don't have to tell me that, everybody knows that grandparents are one of the better things in this world. Who else is going to stick up for you when it seems that the whole world is against you? Who else would go without Murray Mints just

so you can have that really wicked T-shirt that your mum refuses to buy for you?

There's nothing in this world quite like grandparents. It's true that there are some miserable old people out there, but there a load of horrible young people too. I don't believe in all this age-ist crap. Rave on, Mrs Turner. Ed.

CRAPNESS AHOY!

On seeing recent attempts at poetry in your magazine, I'm sending you one of my own fabulous pieces. It's a variation of Three Blind Mice...
Three blind fish, Three blind fish.
See how they swim,
See how they swim.
They all rushed off to get YS,
They read it all and now they're dead.

Ha! Ha! Ha!
Johan Shwarzki
Laleham, Middlesex

FEMTO PICO



CLEVEREST SCIENTIST ON EARTH

Femto's back after a Christmas holiday which would have put most people in a mahogany casket with flowers on the top. But he's soldiering on despite even more setbacks...

It's a crime wave. I woke up a couple of weeks ago to see those Gaelic popsters U2 breaking into my brand new Trabant, parked outside the flat. Panicking, I struggled into my clothes but misguidedly put both feet into one leg of my dungarees. As I hopped outside and up to the car (which Bono and The Edge were just hot-wiring), I lost my footing and fell over a full can of paint-stripper.

The contents of the can went all over my beautiful car, and within seconds there wasn't a scrap of paint left on its gorgeous bodywork. Gunned, I started to cry. To my astonishment I heard the whole of U2 start blubbing along with me. Sniffing, they said how sorry they were, and how they hadn't wanted to turn to crime, but they'd been a bit short of money since the release of The Joshua Tree and just couldn't resist trying the door handles.

So I left them with their spray cans to get on with a respray. About twenty minutes later I came back and hey presto! An album cover was born!

They'd also made a hell of a mess of my car. Who's going to pay for that, eh? Now a letter.

Dear Femto
Thanks for making my video. I know it cost a few bob, but I reckon it was well worth it. All the shape-changing stuff you included was a dead good idea. So I'm well chuffed, me. Cheers.

Michael Jackson

I know what you're thinking readers, but the video I made was for The Michael Jackson Carpet Shop in Pinner. Mike asked me to do a local TV ad for the Axminster Stone-Resist Shape Change Fit-U-Like shag-pile.

See you next time readers. And remember, 6pm to 6.05 is Happy Hour in the Neon Teepee, Penge. You can get a Cola for just £5.22 and every one you buy makes us very happy indeed.
Femto

WONDERFUL WORLD OF SPECCY



NOTHING TO SAY

I must leave you know, with nothing more to say than this old Dutch saying: Meestal een komkommer, als het handdoekenrek je pantoffels heeft gelezen. Bye.

Abdon Pijpelink
Lerneuzen, Netherlands

I don't know what to say, I'm completely overcome. I don't think anybody's ever said such a nice thing to me. I'm sorry I can't say something as nice about you but, well, I hardly know you.

Actually readers, I'll come clean. I haven't the slightest idea what old Abdon's talking about. But I like to think that it's something witty and charming cos that's just the kind of dude I am. Ed.

STAR LETTER



CHASE ME

I was reading Joystick Jugglers in your mag and I noticed that James Leachy-babes was talkin' all weird. What have you been doing to him? Oh, and what's your favourite game, Ed?

Matthew Barratt
Ashby-De-La-Zouch,
Leicestershire

I wish I came from Ashby-De-La-Zouch, it's such a rad sounding name. Mind you, I bet it's a really boring place full of nice villas and

elm trees. Bleurgh! Give me a good old block of flats any day.

You might think that tower blocks are really ugly, and loads of people would agree with you, but I like them. They're the best places in the world for skateboarding. In fact, I think that that's what the architects probably had in mind. Cool dudes, architects.

Going back to Ashby-De-La-Zouch for a moment, I think it's the De-La that gives it that touch of class. How about Andy-De-La-Hutchinson? Mmm, for certain occasions it's the perfect name. On the other hand, it's a bit girly. Which brings us quite neatly onto your point about James. I don't need to put anything in his drink, he's quite silly enough as it is. As for my fave game, that's easy, it's kiss chase.

You can have the Star Letter just for coming from such a beautiful place. Ed.

PETER SNOW'S DEAD SERIOUS CORNER

SOB

I would just like to express my feelings on a certain point. Sixteen bit games are not being converted to the Spectrum. With 346K per +3 disk it would only take three disks for a one megabyte programme and the sound and graphics would not take as much memory anyway.

David Groves
Abbeymead, Gloucester

You're absolutely right David, software houses

are ignoring one of the most successful computers ever, in pursuit of those other 16 bit creations. That's why next month, we'll be starting our Save Our Speccy (SOS) campaign. Inside the magazine you'll find a letter which you can sign and then send off to the big software houses. This letter does woggles of complaining about the lack of support for the Speccy. So if you want to continue getting many years of use from your beloved computer, fill in the letter and send it off to the software houses. **Ed.**

DOUBLE SOB

I was on the school bus yesterday (as is usual on a week day) and we were talking about how good computers are (as is usual on a week day) when I asked what computer everybody had. They had Amigas, STs and Megadrives. When I said I had a Speccy they all burst into fits of

giggles. I just couldn't understand it.

So now I sit on my own in a remote corner of the bus talking to myself about how ace Spectrums are. They do say it's the first sign of madness.

Dominic Scarr
Hull

*Listen Dominic, the next time these goons take the mickey out of the Speccy, simply ask them how many STs or Amigas have been sold worldwide. When they reply by saying "about a million," point out that there are about five million Speccys out there. Then ask them if their 16 bit machines will be around after ten years. I think you'll find them changing their tune after you lob these statistics at them. If they don't, give me a ring, and I'll come round and give them a good hard kicking! **Ed.***

That really isn't very good, Johan. In fact, it's completely appalling and I'm sitting here completely appalled. Fish are kickin' and you've insulted them. In response, I'd like to share with you my fish ode. It's called Bream.

*Little fishy in the stream,
Cool and silent as a dream,
How do you fit into the scheme
Of things, bream?*

*Romantic, isn't it? If I wasn't a magazine editor, I'd be a poet. Not one of those soppy poets, mind. I don't really agree with frilly shirts and bow-ties. I'd be a rad, street poet. I'd cruise around on my board, making up individual and witty rhymes to everything that crossed my path! **Ed.***

SORRY?

Yo! Howz't hanging, cool dude man? That bad, huh? Never fear, I'ze here to put a hearty smile back on the depressed rad dudes of our nation. I mean, how can it be? Is it true? Did our awesome bunch of kickers finally run out of kick? For a supposedly crap bunch coming second in the world is pretty radical stuff. Like hanging ten whilst standing on your head, man! Hang ten.

Rob 'Rad' Little
Guildford, Surrey

I'm sorry, do I know you? I suppose that this is just the sort of letter I should expect if I go round skateboarding and using the word

rad. But, you've got it all wrong, Rob. Real street dudes do not go round saying things like 'I'ze', they only do that in films. But you're nearly there, a couple more years hangin' out and you'll be okay.

*I used to think 'Hang Ten' was an ace phrase but I've just been informed that it was the title of a Soupdragons' song before they were cool. So I'm not going to use it anymore, and I advise you to do the same. **Ed.***

STOOPID

The whole idea of you being mates with EMF is one of the stupidest things I've ever heard.

Jonathan Cant
Hebden Bridge, Yorkshire

Well, you obviously haven't heard about the time James drove into a stop sign. Or the time Linda fell asleep in the toilets at a gig and missed the whole thing?

*And how about the time I did a plain header dive into the 2' 6" end of the pool and broke my nose? Oh, I know loads of stupid things. **Ed.***

SMALL



PRINT

*I love Marianne. She is so lovely. **Adam Mitten, Rochester, Kent** Actually, she's a slime monster from hell and you're welcome to her. **Ed.***

*Do you ever feel alone at night when you are playing on your computer. **Clint Page, Bristol** Come off it! I'm a popular and rockin' dude. Alone isn't a concept I'm familiar with. **Ed.***

*Bath is so rockingly rocktastic that it's hard not to be overcome with excitement. **Jazzy B, Bath** That's how I feel about Baywatch extras. **Ed.***

*Have you seen my runaway cabbage? **Calli Flow, Bolton** If he was a bit crusty with a limp he went that way. **Ed.***

*I think your long addresses for your compos are stupid. **Colin Brown, Glasgow** I think your Doctor Who pyjamas are stupid. And don't try and pretend that you haven't got any. **Ed.***

TRAINSPOTTERS



GET IT RIGHT

*I would like to claim a Trainspotter cos in issue 72 you wrote "if he falls off he ould get a nasty bump." I may be stupid and mad but I do know that their (sic) is no such word in the English Language as ould. Get out of that one if you can. Ha! Ha! Ha! **Kenny Cooper** Dunkinfield, Cheshire*

Sorry and eveything, but I happen to think that Trainspotters should only be awarded to people who can write a nine line letter without getting anything wrong. Call me Mr Meanie, but that's my honest

*opinion. I think you'll find that "their is no such" should be "there is no such". Ha! Ha! Ha! **Ed.***

NO WAY

I want to tell you about your thick mistake in issue 72. In the top 100 games of all time you start from 100 and go to 75. Then you go from 74 to 50. Then you go from 49 to 24 instead of 25. So please, with sugar on top, give me a Trainspotter Award.

Ross Avis
Newcastle Upon Tyne

*There's absolutely no way you can have a Trainspotter. There are no set rules that say we have to have a certain number of Top 100 placings each month. It all depends on things that you know nothing about, like layout and design and what I feel like. **Ed.***

TOO EASY

I hereby claim two Trainspotter Awards for spotting two mistakes in your mag. The first, oh delectable supplement, is for noticing that your December covertape was marked number

eight, despite being number nine. A brilliant observation if ever there was one.

The second, oh stupendously excellent mag, is in your top 100 games of all time. You say that Rafeale Cecco only made one good game. Incorrect! You are obviously not counting Exolon.

Alex Hannam
Linton, Cambridge

Sorry, you can't have two Trainspotters, you can't even have one. Your first observation was commonplace in the extreme. I think I must have opened about a thousand Trainspotters this month and they all mentioned the fact that we put the wrong number on the tape. It got so boring that I had to make James open all the letters whilst I took a three hour lunch break to check out the Addams family. It was ace.

*Your second claim rests on opinion rather than fact, so it doesn't count. The Top 100 reflected what Stuart thought, not what he knew. You can know that two and two are four, you cannot know that any band are the best in the world. Well, I can but then I'm an editor. **Ed.***

WIN!!!!!! You could be the lucky recipient of a smashing pair of socks!

What ho, Spec-chums. As you can see, this page of the magazine is chock-full of questions and little boxes, more commonly known as a questionnaire. You see, we'd like to find out what you want from YS and how you'd like us to change. If you want to remain anonymous, then leave the address section blank, but if you fill it in you could be the lucky recipient of a pair of fab socks!
Anyway, I'll have a 1, please Bob!

1. What sex are you?

- Female Male

2. How old are you?

- 3-7 8-15
 16-20 21-30
 31-100 Fossilised

3. Which county do you live in?

4. Do you have any brothers or sisters? If so, how many?

- Brothers: One Two Three Four or more!
Sisters: One Two Three Four or more (gosh!)

5. Which other magazines do you read?

- Sinclair User C&VG
 Crash Amiga Format
 ST Format Amstrad Action
 Commodore Format Sega Power
 Amiga Power Smash Hits
 Fast Forward Look in!
 Viz 2000AD
 Teenage Turtles Shoot!
 Match Just Seventeen
 My Guy Mizz
 19 Rage
 Number One Big
 Company Cosmopolitan
 Elle Looks
 Other

6. Roughly how much time do you spend playing with your YS Mag 7 covertape?

- Less than an hour 1-5 Hours
 6-10 Hours 11-20 Hours
 More than 20 Hours

7. What religion are you?

- Church of England Catholic
 Muslim Hindu
 Jewish Methodist
 Mormon Buddhist
 Whicker Man Teapot of Mumu
 Nothing thanks! Other

8. How important do you think religion is in the 1990s?

- Of overwhelming importance
 Extremely important
 Of average importance
 Not terribly crucial
 Of no importance at all

9. How much pocket money do you get each week?

- Under £1 £1- £2
 £2 - £3 £3 - £4
 £4 - £5 Over £5

10. If you have a Saturday job, where do you work?

11. How much money do you spend a month on...

- a) Clothes?
 Under £5 £5- £10

- £10 - £15 £15 - £20
 £20 - £25 Over £25

b) Records/cassettes/CDs?

- Under £5 £5- £10
 £10 - £15 £15 - £20
 £20 - £25 Over £25

c) Going out?

- Under £5 £5- £10
 £10 - £15 £15 - £20
 £20 - £25 Over £25

d) Magazines?

- Under £5 Over £5

e) Cosmetics (like hair gel, visits to the hairdresser etc)?

- Under £5 £5 - £10
 £10 - 15 Over £15

12. Do you have a bank or building society account at any of these establishments?

- Nat West Midlands
 Lloyds Barclays
 TyeSB Bank of Scotland
 Girobank Abbey National
 Halifax Leeds
 Nationwide Alliance & Leicester
 Woolwich Bradford & Bingley
 Other building society (which)?

Other bank (which)?

13. Which of these machines do you own?

- Speccy 48K Speccy 128K
 Sam Coupe Amstrad CPC
 Atari ST Amiga
 Commodore 64 Sega Master System
 Nintendo Famicom Sega Megadrive
 Nintendo Gameboy Sega Gamegear
 PC Compatible Macintosh

14. How much do you intend to spend on computer kit this year?

- Under £25 £26- £50
 £51 - £100 £101 - £200
 £201 - £300 Over £300

15. When you buy software, where do you get it from?

- Local specialist computer shop
 WH Smith
 John Menzies
 Boots
 Department store (like John Lewis)
 Mail Order
 Catalogue
 Computer shows

16. Which political party will you (or do you) vote for?

- Conservative Labour
 Liberal Green Party
 Other (please name)

17. How important do you think 'Green' issues are?

- Extremely important
 A little bit important
 No more important than eating properly
 Not terribly important at all
 I wish people would stop talking about blimmin green issues!

18. Which of the following do you consider important issues? Rate them accordingly, eg - put a 1 by the most important one and a 6 by the least important one.

- AIDS
 Animal Rights
 The Poll Tax
 Nuclear Disarmament
 World Hunger
 Pollution

19. Roughly how much TV do you watch a week?

- 0-5 hours
 6-10 hours
 11-20 hours
 21-30 hours
 30+ hours

20. Which are your favourite channels?

- BBC1 BBC2
 ITV Channel 4
 Sky One Sky News
 Comedy Screen Sport
 Sky Sports Euro Sport
 Children's Channel Lifestyle
 MTV Europe Sky Movies
 The Movie Channel

21. What's your favourite TV programme?

22. What sports do you play?

- Football Netball
 Rugby Hockey
 Running Swimming
 Shooting Horse Riding
 Motor Sports Snooker
 Tennis Badminton
 Squash Ice Skating
 Gymnastics Cycling
 Skateboarding Cricket

23. Who's your favourite band?

24. Which celeb do you think is really dim, stupid and completely appalling? (Apart from Kylie and Jason.)

25. Which celeb do think is smart, rad and well cool? (Apart from Kylie and Jason.)

26. How often do you go to the cinema?

- Never Once a year
 2 or 3 times a year Every month
 Every week

27. What was your favourite film of 1991?

28. If you've got a video recorder, how often do you rent a film?

- Never Once a year
 2 or 3 times a year Every month
 Every week

29. What was your favourite video of 1991?

30. Roughly how much time do you spend playing with your Speccy in any one week?

- Less than an hour 1-5 Hours
 6-10 Hours 11-20 Hours
 More than 20 Hours

Name.....

Address.....

.....Post Code

Thanks a million for filling in the form. Now send this page (or a photocopy) off to YS Sock Survey, Future Publishing, Freepost, 29 Monmouth Street, Bath, Avon, BA11XY.

DOUBLE DRAGON

Storm's *Double Dragon 3* has hit town. There's loads of violence, plenty of punching and a bit of kicking. We sent Linda Barker off for a spot of aggro, and we made sure we weren't around when she got back.

The all-action, oriental beat-'em-up is back, with all our old friends in tow. There's the pretty but dim Marion, her man Billy and his best mate Jimmy. These are the good guys, on the other side of the room we have the forces of evil – it's the dreaded Black Warrior gang.

This time the Black Warrior gang, in a desperate attempt to keep Marion all to themselves, have issued a ransom demand. Bill and Jim have got to find the Rosetta Stones, hand them over pretty sharpish and kick a lot of people.

Now, Rosetta Stone were an extremely crap seventies pop band from Bristol who pretended to be the Bay City Rollers, nobody believed them and they sank into obscurity. Why, oh why, would anyone in their right mind want Rosetta Stone? Obviously, these villains are out of their tiny little minds. (*I don't think they mean the pop band actually, Linda. Ed*)

Oh, hang on, let's have

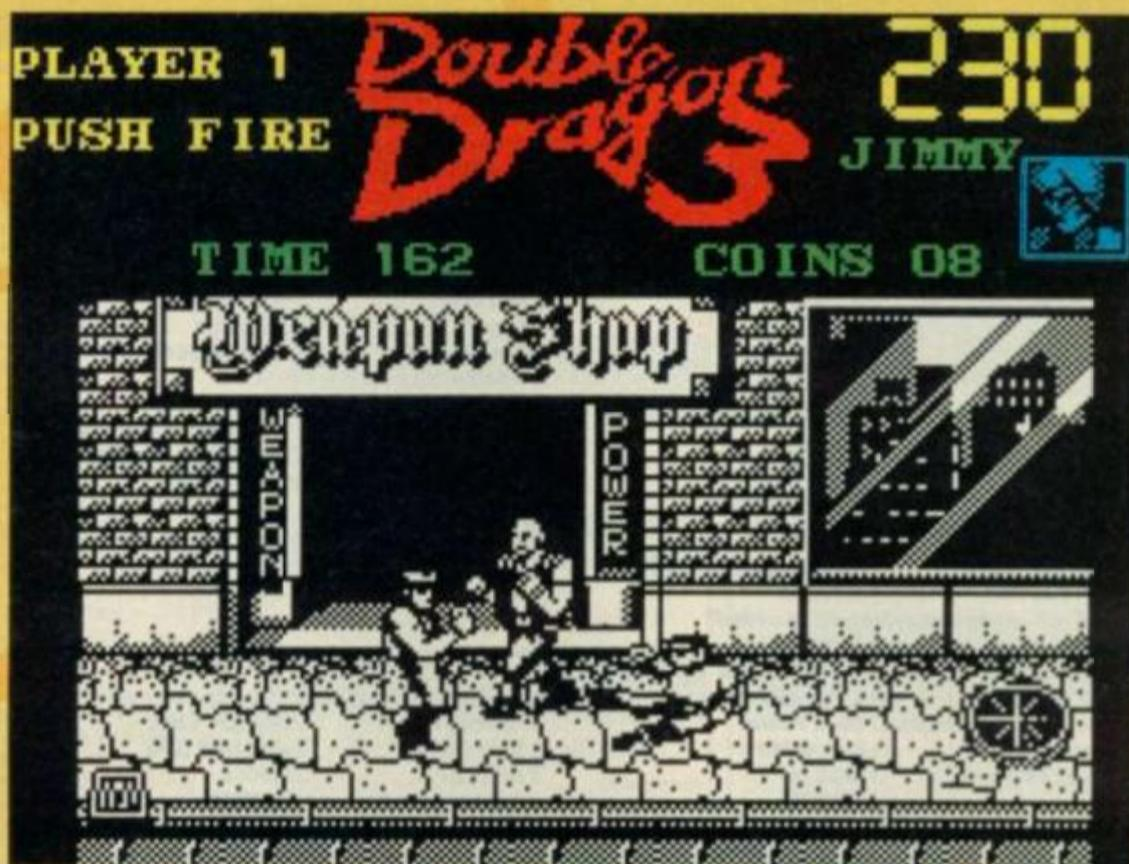
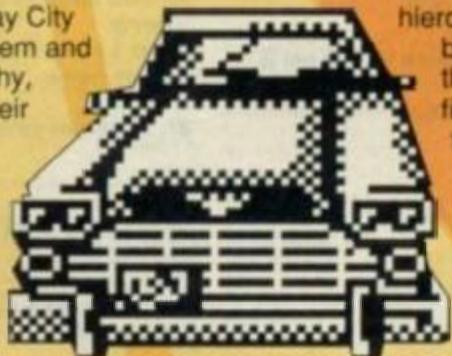

Get up and fight like a man, you lily-livered cowardly chicken-head! And you wipe that smile of your face, young man. Oh, and get a decent haircut for goodness' sakes.

a look in the encyclopedia. Ah, the real Rosetta Stone is a slab of black rock covered in Greek and Egyptian hieroglyphics. It was a pretty big discovery cos it meant that hieroglyphics could finally be deciphered for the first time. It's now in the British museum.

Here's another question – are Bill and Jim meant to break into the British museum? Well, no. Cos the Stones, for the pur-



I've just got to nip in here and pick up the latest Chesney Hawkes LP before going off for another round of serious fighting. With any luck it'll get totally destroyed in the melee!

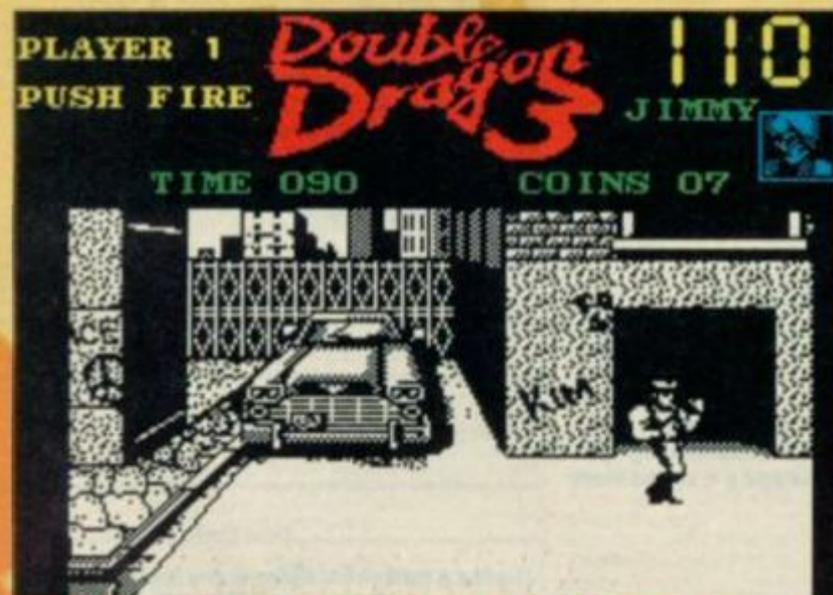

Oh! Aren't you that construction-worker bloke out of the Village People? Yeah! You are! I saw you back in 1980 playing the cabaret circuit. You looked really stupid and I thought all your songs were complete crap. I was appalled. Can I have your autograph?

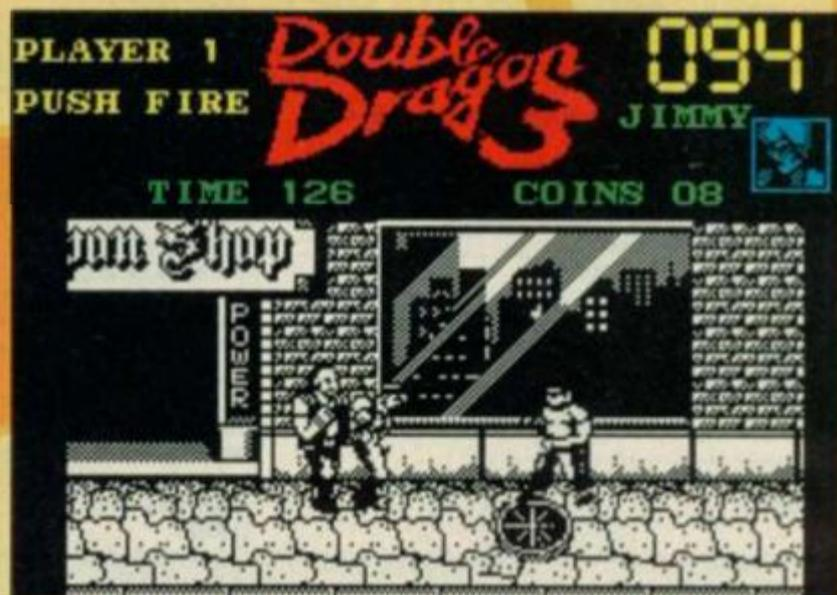

This punk is a wee bit tougher than most of the other weeds. He's got a punch like an elephant's head-butt and he can take a massive amount of punishment. But tickle him and he's as weak as a baby. Note how the city's architecture is lovingly reflected in the windows.

DRAGON 3

The other two

Double Dragon from Melbourne House kicked off the series in the beginning of 1989. It was a coin-op conversion in which the lush and gorge Marion got taken away by the Black Warriors for the very first time. Bill (and Jim, if you used the two-player option) went after her and had a jolly good time kicking, slicing and slashing every nasty ninja who crossed the garden path. Eventually he got old Marion back and the two lived happily after. Well, until Marion got carted off again.

Double Dragon 2 was released by Virgin and was even better than *DD1*. Marion, who seems to be a bit of a dozy cow, went and got herself kidnapped again. Y'see, Bill and Jim hadn't killed the entire Black Warrior gang at all. A girlie with the rather evil and hard name of Linda survived and brought all the others back to life. This time the Black Warrior gang refused to take any chances with sappy Marion and, erm, killed her. So it's a bit of the same again please. Basically.

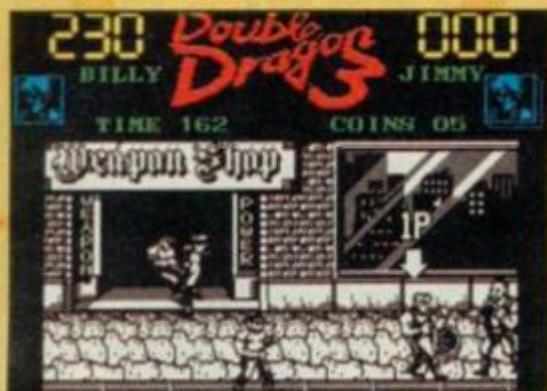

Ah! Ye Olde Weapon Shoppe. Perfect for picking up those after-dinner knuckle-dusters.

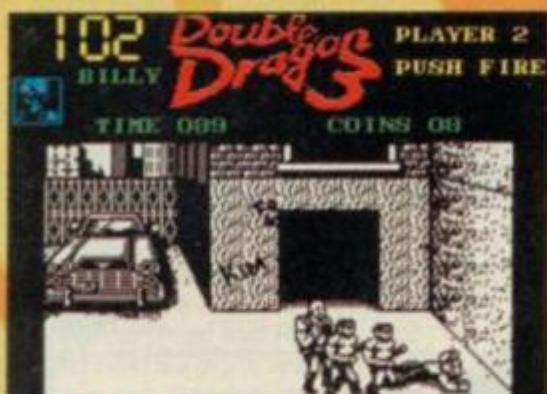

There's three of you and one of me, and you've punched my face in. Let's call it a draw.



You're supposed to fight, not teach me poncey dance steps, you lanky buffoon!

pose of the game, have ended up back in Egypt somewhere. (There are also more than one of them.) To get to the stones Bill and Jim have to consult the wise old, bearded Hiruko and race through five countries. Each country (US of A, China, Japan, Italy and Egypt) represents a level and each is split into 14 smaller bits. On each bit you have to try out all their fancy moves on loads of aliens. Yep, aliens. Y'see they started all this trouble in the first place,

and there are loads of them to get rid of.

So, it's an oriental beat-'em-up with, erm, a few aliens hanging around. You can choose the single player option, but you might as well get Jim in on the act and go for the two-player option. After all, that's why it's got the word double in the title, isn't it?



The world's strongest enemies

- Jeremy Beadle
- Hunger
- Greed
- The Welsh rugby team
- Jealousy
- The entire capitalist/ Imperialist system (one for all you anarchists)
- David Bowie
- Pride
- Santa's Xmas Capers
- Chicken McNuggets

What's new, pussycat?

The original *DD* was noted for its 3D effect whereby you could crawl up, over and into things. The same sort of thing happens here, so you can throw things at your enemies and pick up and use any useful stuff that you find lying around. At the end, Storm promise that you'll come up against the world's strongest enemy. But they won't tell us what it is, boo hoo!

There's more baddies than in any other *Double Dragon* game and they're tonnes tougher. Luckily there's also a wonderful little shop which sells the most amazing mortadella, erm, I mean weapons. Here you can buy all manner of death dealing and cranium-cracking devices like nunchuckas, grenades, missiles, knuckledusters and swords and extra lives. Gee, a shop which sells life. I wonder what form it comes in, solid or liquid? If none of these grabs your fancy, how about handing over a few pennies for a locking head squeeze, a handstand ankleflip or a one armed head-butt?

If, after all this, you still feel a tad under-armed just kill someone. Y'see, you also have the option of taking on the skills of your opponents too.

Just one last thing - it's due to be made into a multi-million dollar film. Hurrah, or what? ☺

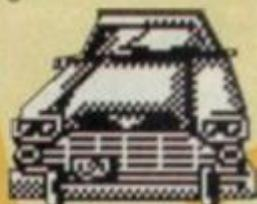

Double Dragon 3 the million dollar fillum

- In which Harrison Ford makes his way from his farm in Indiana to Egypt via China, Japan and Italy. Along the way he becomes involved with some chopstick-wielding baddies, an egg-foo yung breathing dragon and a femme fatale clothed entirely in empty egg boxes. He gets the Stones, gets his girl and takes the first plane home. 30,000 feet above Tibet hijackers appear... to be continued.
- In which Bruce Willis leaves his penthouse suite in New York to travel to Egypt. Along the way he loses his shoes. Before getting the Stones he obviously has to find his shoes. This involves a rather long journey through China, Japan and Italy. It also involves lots of swearing, sweating and walking on glass. When he gets to Egypt, he finds the Stones in a large air-conditioned hotel. As he leaves, the whole building bursts into flames... to be continued.
- In which the KLF visit Des Moines and pick up an ice-cream van for the paltry sum of \$3. Their trip to Egypt (via China, Japan and Italy) involves lots of flakes, wicker men, crashes and cornets. When they get to Egypt they disguise the Stones as 50 pence cones. Oh, and Marion is played by Tammy Wynette.

FAX BOX

Game	Double Dragon 3
Publisher	Storm
Programmers	Storm
Release Date	January
Price	Cass £11.99

BUBBLE DIZZY

CodeMasters/£3.99 cass



JAMES

The Codies seem to take great delight in mistreating their little pet egg, Dizzy. He's been thumped, kicked, bashed, scrambled and dropped in his games so far. Now the cruel so and sos want to drown him.

Actually, CodeMasters are using this game to fill in a blank in Dizzy's rather stupid history. There seems to be a fuzzy part of his life in between when Captain Blackheart made Dizzy walk the plank and when he was washed up on the island in *Treasure Island Dizzy*.



Avast, ye barnacled varminits! Shiver me timbers or I'll gi' ye a lick o' the cat, ye lily-livered landlubbers! (Was that all right, Larry?)

Bubble Dizzy is supposed to tell the mystic tale of what went on in those fear-filled moments. You see, the water he was dropped into was rather deep. He tumbled into a series of underwater caverns, and arrived at the bottom in one piece. Now of course, he wants to head for the surface even though, being an egg, he doesn't actually breathe.

To rise through the water, Dizzy has to hitch a ride on the bubbles which are coming out of the sea bed. The bubbles, which are rather fragile things (according to CodeMasters), burst after a while, so he must make the ride last as long as possible.

I've got a query about this. If the bubbles Dizzy's riding on are underwater, how can they burst? Where does the air go? Up his bum? The simple truth is that bubbles can't burst underwater. I checked in the *YS Book Of All World Knowledge* and it confirmed that the Codies are talking crap.

Anyway, as well as these bubbles, there are oysters containing pearls which you need to collect. These are guarded by vicious sea creatures. There are electric eels, huge whales, sea horses and other fishy foes, aquatic adversaries and piscine perils. (Good bit of writing, that.)

5 FRIGHTENING UNDERWATER FACTS

- The Loch Ness monster lives underwater, but has been seen crossing local roads in the dead of night.
- Most electrical things don't work underwater, except, strangely, submarines (and aqualungs).
- And James Bond's car.
- A man once spent four hours underwater in a swimming pool without an aqualung, but when he came up he was dead.
- The moon has no water on it, but if it did, there'd probably be loads of otters and trout living there. And bream. And chub. And halibut.

Some more good writing

The game has got about eight levels, each following on from the last in some vaguely logical order. (Have you actually played this game, James? Ed) For example, you eventually come ashore next to the ship where the evil Captain threw you in, then you've got more to worry about than simple bubbles. Yes indeed, there are land creatures giving you grief.

The thing with *Bubble Dizzy* is that it relies tremendously on luck. The bubbles emerge at random, and the only way to rise on them is by jumping on a slow one or leaping into space and hoping for a fast one to come up and catch you from behind. The bubbles burst in all the wrong places, no doubt because the programmers had a bad drive into work that morning. This means that you'll usually have to leap just as it bursts in order to get onto a ledge.

Luckily, the sea creatures around you move in set patterns. They ignore you completely, making it possible for you to try and time your upwards moves when they aren't directly overhead. Sounds fine in principle, but when you're panicking cos you haven't seen a bubble for ages and the shark is coming around for another pass, you'll forget everything you're supposed to be doing and just hammer the fire button to jump.



Proof that sharks will eat eggs. Dizzy, having fallen off a bubble, disappears down the throat of a ferocious undersea predator. This bit would be even more enjoyable if you could hear his screams as he's munched by the monster.

Graphics and sound are well up to the usual Codies standard, and Dizzy is just as you've always known him, if slightly more hard-boiled. He's still pretty much a sprightly little fellow with bouncing arms and a variety of facial expressions. Shame he's going to drown, then isn't it? (Hur hur.)

In an increasingly monochrome Speccy world, there's plenty of colour around as well. It's rather touching and, I always feel, slightly moving (*Steady on, Monsieur Leach. Ed*) to see that CodeMasters are still making their games bright, brash, noisy and exciting, oh, and rather smooth with it, even if there is the odd colour attribute clash.

Yes indeed, *Bubble Dizzy* is an arcade-type game of the choicest amusement. It's as addictive as only the Codies know how. Well, a few other people know how as well, but probably not quite as much as the Codies.

Anything wrong with it? Well, as I said so succinctly above, it's a rather tough game, relying on your dogged persistence and gritted teeth rather than incredible skill and bodacious timing. This is the main difference between this *Dizzy* game and all the others. Also, there are no quests to go on like in the other Dizzscapades.

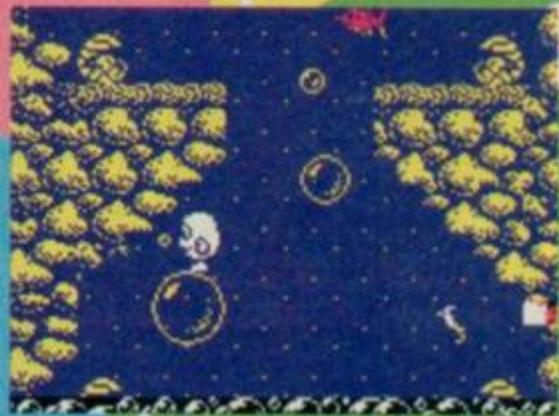

Dizzy rises happily on his egg, unaware that his head is about to be crushed in by that overhanging ledge above him. If this happens he falls back to the bottom and you cry.

Oh yeah, and Dizzy can't go round collecting things to use later, either. So in fact the two styles are really rather different.

So, if you don't mind being frustrated and annoyed because you've just fallen to the sea-bed for the thousandth time, pick up *Bubble Dizzy* in WH Smith's, walk briskly up to the sales staff and express your desire to own it. It's fairly wise to make sure you have the correct payment about your person at this stage. If you haven't, you'll be in for a serious bit of embarrassment. Anyway, assuming you do have the monies required, those ever-friendly and helpful staff should ease you through the following financial transaction effortlessly. You are then free to leave the shop with your newly-acquired purchase. The game is then yours to treasure or transform into a brooch. The decision is yours! ☺

BLIM!

The first person to make smelly bubbles in the bath was Confucious. This happened the morning after he ate the very first baked bean, egg and kebab sandwich!



YS ADVENTURES



TIM KEMP's decided that Tim's a really unadventurous name, so he's changing it to Zzowervyxx. It won't last.



To say that the adventure scene has been 'buzzing' lately would be a colossal understatement. For a few years now there has

been only one main adventure fanzine on the scene. Sure, other 'zines have come and gone over the years, but *Adventure Probe* has been the mainstay, if not the backbone, of home produced adventure publications for over five years. I thought I'd have a bash at publishing one too, and came up with *From Beyond*. Now I find that several other fanzines exist, and are really going strong. If you have heard of *ZAT*, *The Adventure And Strategy Club* and *Red Herring* (the new one on the scene) then you should, by now, have treated yourself to a copy of each of them. (It's the only way to find out exactly what they're like.) Those are just the paper 'zines - there's a whole host of tape-zines too! In a future issue I'll be reporting fully on the adventure 'zine scene and will endeavour, from time to time, to keep you fully informed on what's available, what's happening, what's good and what's not.

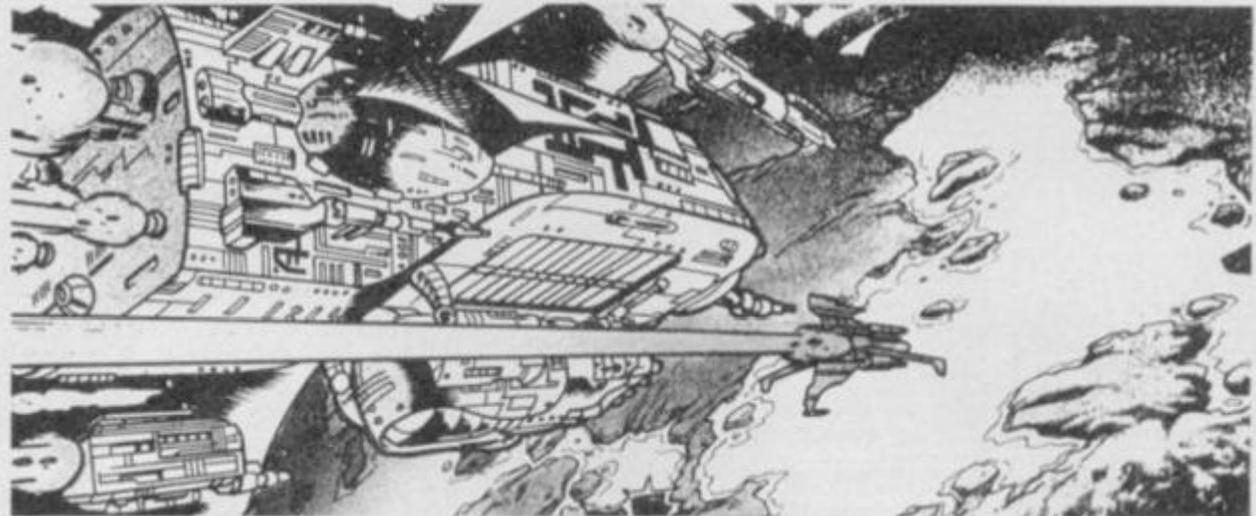

But hold on... it's not just the fanzine producers that have multiplied of late. Zenobi Software were the only 'Big Boys' on the adventure game scene until recently, though now we have GI Games (specialising in classic re-releases and golden oldies), and another addition to the adventure publishing clan has just emerged. The Guild, for



such is its name, hasn't just burst onto the scene - it's exploded.

Most prominent among the initial batch of games is a brilliant compilation tape featuring some of the very best adventures that you're ever likely to see. This compilation goes under the title of *Guildmasters Vol I* and features: *Into The Mystic* by Jack Lockerby, *Captain Kook* by Paul Cardin, *Nythyhel* by Tony Collins, *Magnetic Moon* by FSF Adventures and the perennial classic *Book Of The Dead* by The Essential Myth. What's more is that *Into The Mystic* is the only one-part game on the compilation, the others having two - and even three parts in the case of *Magnetic Moon*. The price for this enjoyable mixture of sci-fi and fantasy, text and graphical adventures? A mere £4.00. Add £1.00 extra to cover postage if you live outside the

UK and make cheques payable to Glenda Collins. There are currently 18 titles in The Guild's software catalogue, and six of them are compilations. Prices for single games/tapes are £2.00 and compilations range from £3 - £4.00 each.

To celebrate the arrival of The Guild, Tony has generously knocked some money off a few of his titles, and the details are printed along with the coupons elsewhere on these very pages. In the meantime if you are desperate for more info on the complete range of adventures in The Guild catalogue then you can contact Tony at: The Guild, 760 Tyburn Road, Erdington, Birmingham B24 9NX and enclose an sae for their latest list of adventure goodies.

At 5:30pm (Galactic Mean Time) last Tuesday week, In a galaxy quite a fair bit out of the way... BUG WARS. It is a time of civil war. Rebel spies have managed to steal secret plans to the evil Galactic Empire's ultimate weapon... THE DREAD STAR! Princess Leea, hoping to return to her home planet Balderaan, is intercepted by a fearsome Star Bruiser! Captained by no less a dude tahn the Dark Lord of the farce himself... DAFT BUGGER!!!

So begins the opening passage of a truly stupendous graphic novel entitled **Bug Wars**. It's a spoof of the well known film with a similar title, and author and illustrator, Sean Doran, deserves to sell this masterpiece in its thousands. There's a good chance that Zenobi Software will be handling its distribution for around about the two quid mark. It's published in the popular A5 format and has 72 pages. Buy a copy now! If you send an sae requesting more info on Bug Wars to either Sean Doran, 14 Velsheda Court, Belfast BT14 7LZ, N. Ireland or to Zenobi Software, 26 Spotland Tops, Cutgate, Rochdale, Lancashire OL12 7NX, then you'll be sent more info, including the price.



Dave Wheatley of Rainbow Miniatures (whose 25mm fantasy figures were up for grabs in the Dec 91 issue of YS) has moved. Should you wish to contact him about purchasing any of his rather nice painted figures, which make ideal map markers, his address is: Fair View, Cherry Valley, Whithorn, Wigtownshire, Scotland DG8 8AB. His telephone number is: 09885 760. If you are writing to him for a price/product list then please enclose an sae.



- TIM'S TOP TEN 'CLASSIC' ADVENTURES: (IN ORDER OF FAVE-NESS!)**
1. *Adventureland Adventures International*
 2. *The Hobbit Melbourne House*
 3. *Dungeon Adventure Level 9*
 4. *Tower Of Despair Games Workshop*
 5. *The Golden Apple Artic Computing*
 6. *Colossal Adventure Level 9*
 7. *Impossible Mission Adventures International*
 8. *Espionage Island Artic Computing*
 9. *Velnor's Lair Quicksilva*
 10. *Lords Of Time Level 9*

GI GAMES

(8th Day titles) help-line.

As you will all undoubtedly know by now, GI Games have re-released a pile of extra-special golden oldie adventures. This is fantastic if you want to buy a lot of good older games – but what happens if you get stuck in them?

Have no fear... help-line is here! Here are a load of 'getting you started' nudges which will see you get going in the right direction on just about all of their re-releases. (Read the answers in traditional 'Ekim Drarreg' fashion – i.e. backwards and from right to left.)

In Search Of Angels

⊗ Destination RIO: In the James Bond-like car scene when the chase is on, the correct sequence of buttons to press is:

- 1... lechw ottelits = neves nottub sserP
- 2... (NO) enigne tej = evif nottub sserP
- 3... elissim dediug = eerht nottub sserP
- 4... (FFO) enigne tej = xis nottub sserP

⊗ The flight from Casablanca to Tokyo, later in the game, is simply dynamite! To avoid certain death you should:

- 1... etuhcarap a rof taes ruoy rednu hcræS
- 2... dnalsi na hcaer uoy llit gnimmiws trats neht dna enalp eht morf pmuJ

Cuddles

⊗ Right at the start of the game, to escape from the playpen...

- 1... doof ybab eht porD
- 2... hcoorb s'ynnan teG
- 3... yawa ti worhT

⊗ To enter the castle: reidlos eht ot llod eht eviG.

⊗ Once inside the castle you'll discover a flagpole with a rather odd flag. The 'flag' (such as it is) will be needed when you...

(dessag gnieb flesruoy pots ot) draobpuc yppan eht hcræS

Ice Station Zero

⊗ Worried by wolves? All you have to do is... (esrepsid noos yeht dna) 'nug erif' ylpmiS

⊗ If you're having trouble climbing back up the shaft from the valley... tfahs eht fo mottob eht ta nug nooprah eht eriF

Faerie

⊗ To enter the underworld you will need the following objects and items:

stooB eht dna pmaL tiL eht, retaewS eht, efinK eht

⊗ Under no circumstances should you take the following into the underworld...

gniR dnaS, ssalG retaW, neeuQ kcalB eht

⊗ Do you occasionally suffer from a nasty attack of the Ogre's? The easy cure is to... efinK worhT



Four minutes to midnight

⊗ If Sue won't readily go back through the tunnel then this is the rather drastic course of action to take...

hguorht reh yrrac dna tuo reh kconK

⊗ The ringing telephone that you will undoubtedly be annoyed by should be ignored as it's nothing more than a red herring.

⊗ When taking a trip to the computer centre you'll find that the madman, who you have the misfortune to encounter, can only



be pacified if... euS dna aivlyS fo stsisnoc ytrap rouY

A Harvesting Moon

Movement in one area of the game is made so much easier if you can buy a ticket from the booth. To do that you need to get the 50p – this is how to do it...

ti eerf ot semit lareves p05 eht lluP

hToob eht ta ti htiw tekciT yuB

⊗ Keep the ticket handy because you'll need it all the time on the first floor.

⊗ Are you a trusting soul? When you meet the woman in the woods you will win her over if you simply...

seye reh otni kooL

⊗ Do that and she'll reward you by charging your sphere with a supernatural energy. (Good grief!) You have got the sphere, haven't you? if not then you can find it if you...

rewot eht fo esab eht ta yrnosam eht hcræS

HRH

⊗ A bit of a saucy royal romp this... The way to enter Tussards is...

.sdrassuT rof tekciT a uoy evig lliw eh dna snoitca sih wolloF seod eh tahw hctaw dna srae eht raeW. moor 'selrahC dnif dna ecalaP eht ot og, mailliW ecnirP morf srae rebbur eht ekaT

QUANN TULLA

⊗ Pesky Probe causing perishing problems in the hygiene room? Make it go away (so you can take the Sulpha Tab) by...

.moor eneigyh eht otni ragic til a yrraC

⊗ The Sulpha Tab, once you have it, can be used at a certain time and place to enable you to get a disrupter gun – but I won't tell you where the place is... Ha!

Hope that little lot is of some help. If you've got any tips for any adventures then just send them in. Alternatively, if you need a bit of help then just ask.

COUPON CORNER

DELBERT THE HAMSTER SOFTWARE

'Software with a squeak! Yes, here's your chance to sample some of the delights of up-and-coming software house 'Delbert The Hamster'. Delbert's first YS coupon corner appearance sees prices slashed on all their games. Even their newest two-parter, *Brian And The Dishonest Politician* is going cheap! Fill in the coupon and make all cheques and postal orders payable to S P Denyer. Overseas customers please add £1.00 per item to cover the additional postal costs.

TO: Delbert The Hamster Software, 9 Orchard Way, Flitwick, Bedfordshire MK45

FROM:

Name

Address

Postcode

Dear Delbert The Hamster, here's my cheque/postal order for Now send me the following games. I own a Speccy

... *Star Flaws* (includes free B-side game)£1.49

... *Desmond And Gertrude* (includes free B-side game)£1.99

... *Microfair Madness* 128K or 48k version£1.99

... *Brian And The Dishonest Politician*£1.49

Ten things I most HATE to see in adventures: (In order of hate!)

1. Sudden, unpredictable or unexplainable deaths.
2. Location exits embedded in reams of location text.
3. Overly complex character interaction.
4. Too many time limits.
5. Overly hard starting problems.
6. Poorly re-designed fonts.
7. Full screen graphics.
8. Massive mazes, tunnels and cave systems.
9. Location descriptions that need to be scrolled to be read.
10. Black text on a white background.

COUPON CORNER 2

THE GUILD COUPONS

Yet more bargains! Fill in the coupon, stick it in an envelope along with a cheque or postal order for the correct amount of money. Make cheques and postal orders payable to: Glenda Collins. If you live outside the UK and add an extra £1.00 per item to cover the additional postal costs.

TO: The Guild, 760 Tyburn Road, Erdington, Birmingham B24 9NX.

FROM:

Name

Address

Postcode

Guildmasters Vol 1 Compilation. (Contains: *Into The Mystic*, *Captain Kook*, *Nythyhel*, *Magnetic Moon* and *Book Of The Dead*.)£3.50

The Last Believer£1.50

Dungeon Of Torgar£1.50

Alstrad£1.50

Out Of This World Vol 1 (compilation featuring: *Jhothamia 6*, *Survival* and *Arlene*)£2.50

Ten things a good adventure should have:

1. A well crafted storyline.
2. A monstrously horrible arch-villain.
3. Magic.
4. An unbelievably heroic hero.
5. Dragons.
6. A sidekick or occasional companion/helpful friend.
7. A HELP command.
8. A strangely named mystical character or place. (Preferably something that starts with a couple of Z's, followed by a few vowels and ending with YX. Like the great wizard ZZoweryyxx!)
9. A scoring system that enables you to either complete the game with or without scoring 100%
10. A well thought-out and complete parser.

THE MAPPER

By far the most popular Spectrum adventure writing utility nowadays must be Gilsoft's *Professional Adventure Writer*. The PAW (as it is commonly and affectionately abbreviated to) provides a very flexible framework to build on. It's normally used in a rather limited fashion, with many of its intricacies, functions and possibilities not being explored to the full. So, when a game like *The Mapper* comes along, what can a guy do except rave about it?

Despite being a Zenobi game *The Mapper* comes with rather more packaging than you're usually treated to. You get several sheets of info concerning some of the life forms, flora and fauna that you'll come across whilst exploring and mapping a sector of the planet Pollux 3. (What a funny name for a planet. Ed) This planet is 'potentially habitable'. Y'see, earth's suffered a serious baby-boom over the last few hundred years, so new planets have been targeted for colonisation.

You're a mapper and it's your job to map the 14x14 zone you've been allocated on Pollux 3. You've also got to collect specimens and data that may be of use to either you, or the boffins who are eager to see what lies on Pollux 3. Armed with a self recharging laser, knife and backpack you're ready for anything.

Once the game's loaded a series of display boxes appear. These form the front-end of a rather radical approach to adventure playing. Normally you would have found yourself staring at a screenful of text, but in *The Mapper* everything is controlled and displayed in, on, or near these display boxes.

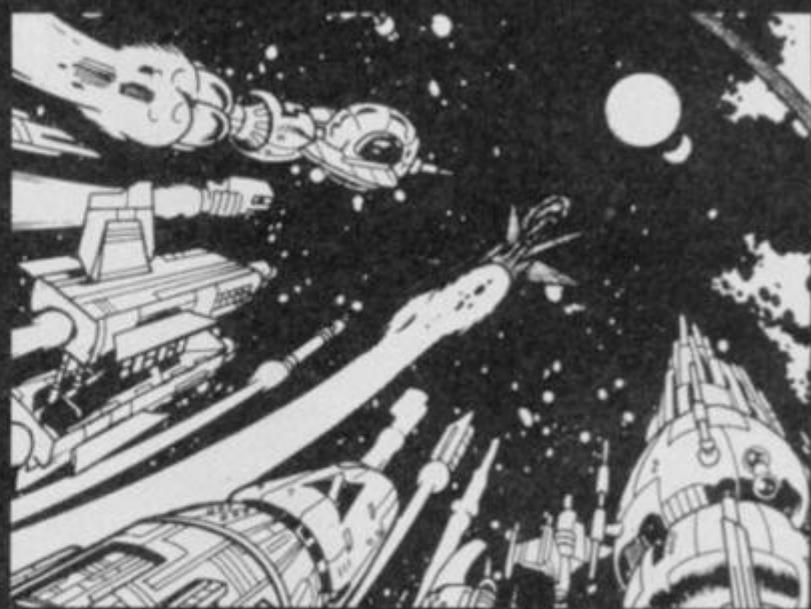

The first thing to get to grips with is the area of the screen (a bordered box) that displays your current position on a small 3x3 map.

Then you can start exploring. Travel, communication and progress in the game is achieved by typing in directions and issuing various commands.

But that is where the similarity between this and most other adventures seems to end. My first (feeble) attempts at doing everyday, mundane things ended more often than not in sudden deaths. SDS (Sudden Death Syndrome) is normally a complete turn-off in any adventure though,

for some reason, it's not so bad in this game. Maybe it's because your first priority is to map the game, so you can, to a large extent bypass the areas where you previously found yourself meeting yet another sticky and sudden end. The creatures tend to stay in distinct areas so, once you know where they live, you can normally avoid them.

The graphics are intelligently and sparingly used. There's a little detailed pic for each creature and plant and anything you're carrying.

After I'd been playing for a while it suddenly dawned on me that the only time a bit of 'lengthy' text appears is when you die or do something drastically wrong.

At first, much of the

pleasure I got from the game came from the map making process itself. It wasn't 'til I reached a dead end that I began to realise what problems lie within the depths of the game. All the mapping you have to do would normally have sent me mad, but the game manages to combine just enough cartography with the right amount of problems. I've got a feeling that, despite its looks, the game will appeal to RPG-ers, text purists (even though there isn't a lot of text in it),

strategy fans and graphic adventurers alike. I'm not overly keen on the fact that it's played in real-time, and that you also need to be accurate with the phrasing of certain commands at times. While I'm

whining, there aren't too many helpful nudges or informative responses to your failed attempts at doing certain things.

One of the game's good points is that there's a rather wonderful Tutorial program on the B-side of the tape. This is an interactive guide to the adventure system used in *The Mapper* and will have you up and running in no time at all.

TEXT ■■■■■■■■■■
VALUE ■■■■■■■■■■
PERSONAL RATINGS ■■■■■■■■■■

The Mapper costs £1.99 and is available from Zenobi Software, 26 Spotland Tops, Cutgate, Rochdale, Lancashire OL12 7NX.

HINTS'N'TIPS

YS



TIPSHOP

February brings the snow,
Makes our feet and fingers glow!
Here's your very own red-nosed winter pixie - it's **LINDA BARKER**. Hurrah!

ALIENS.... 37
STACK UP 33

TIP O' THE MONTH
SEYMOUR GOES TO HOLLYWOOD 36

THE YS MEGAMAP
SEYMOUR GOES TO HOLLYWOOD 34

DR BERKMANN'S CLINIC 37
featuring *Blinky's Scary School, Chubby Gristle, Renegade & Robocop 2*

PRACTICAL POKES 36
featuring *AMC, Hero Quest & Supertanks Sim*



Phwoar! I'm as full as a full thing that's just been filled to the very top. That's pretty full, Spec-chums. I always overdo it at Christmas, I just can't help myself. Every year I say the same thing - "I'm not going to eat any chocolates or sweets or anything in between meals." And I can never do it! Every year I give in to temptation and stuff my face with every single sugary delight that's within reach. It's so hard not to when the tables are laden with Turkish Delight, sugared almonds and everything.s

After the christmas excess it's time to give up everything. New Year's resolutions, eh?

Doncha just hate 'em? Every New Year's Eve I make a really long list of the things that I think I should either take up or give up. If I follow this list, my life will be perfect and I'll grow another five inches. Then I decide that it's all a bit too much bother and I don't really want to grow anymore cos then none of my clothes would fit and all my skirts'd be far too short. So I give up on the resolutions and eat too many crisps and spend too much money on records. Ho hum! Here's some tips...



STACK UP

David Sanders is a Chap (with a capital 'c'). Not only has he written two completely stonking games (*Stack Up* for Zeppelin and *Peking* for our very own beloved cover cassette), he's also sent in some very helpful tips for *Stack Up*. Take it away, Dave...

★ If you're playing in black and white, choose the road signs set. It's the easiest to work with.
★ Clear each level as quickly as possible. The game speeds up through time, rather than through how many lines are made. After each round the speed goes down by

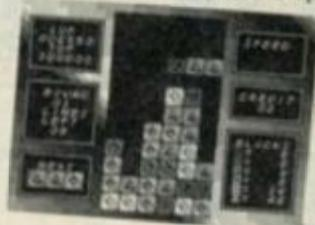

one level.
★ A courage bonus is awarded for starting and finishing rounds three and five.

★ Get used to moving the blocks seperately from each other. When one lands, the others keep going and can still be moved and swapped as normal. With a bit of practise you can place them where you want. Don't land the middle one first by itself or you won't be able to move the other two.

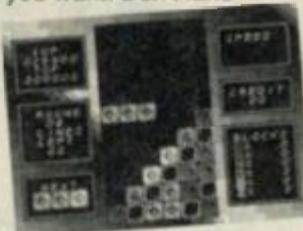

★ Go for horizontal and diagonal, rather than vertical, lines if you can. Besides being worth the least points, a vertical line could leave you with a large trench or column that's difficult to get rid of. Also, remember that a chain reaction can never be started with a vertical line.



★ On the screens where they appear, black and random blocks occur at regular intervals. Random ones appear after every third block set and black ones every seventh block set. Try and anticipate these.



★ If you're playing with a joystick and you reach the rounds with reversed controls, simply turn your joystick upside down.

Gee, thanks Dave...

Hang on, I'm not finished yet! To access the cheat mode, get a high score on the full game (not the practise one) and enter BARR WARS as your name. When the continue option appears you'll have 99 credits to play with.

Barr Wars, eh? Funny name that. But I suppose stranger things happen at sea.

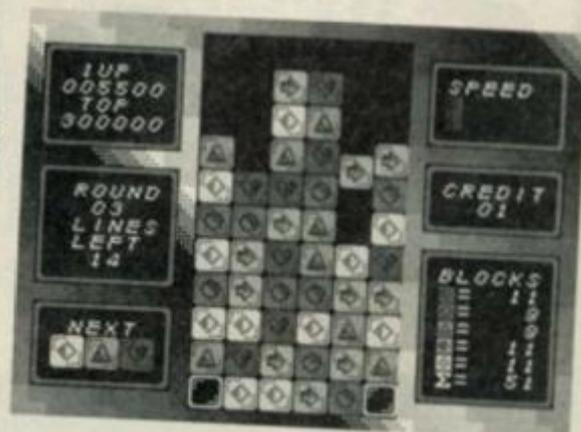

SEYMOUR GOES TO HOLLYWOOD

Lor' luvvavaduck, it's Leigh Loveday. He's been a bit quiet recently but now he's back with a Megamap and a complete solution to the Codies' *Seymour Goes To Hollywood*. You've

all seen Seymour: *Take One* (if you haven't - it was on the covertape last month. Why not grab yourself an issue from Back issues over on page 49?) and this is about the same

lovable slug. According to Richard Eddy at CodeMasters, Seymour isn't a slug at all but a sweet, cuddly little thing. Pih! He's a slug. Take it away, Leigh....



THE OFFICES

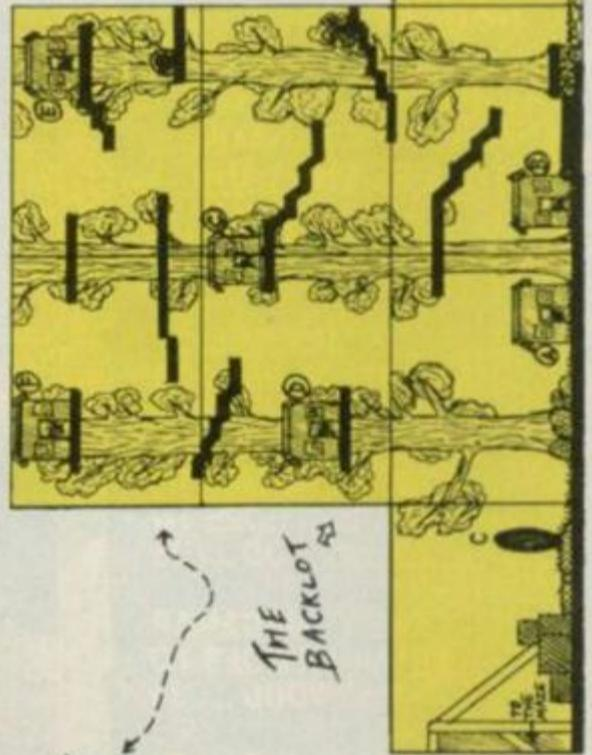
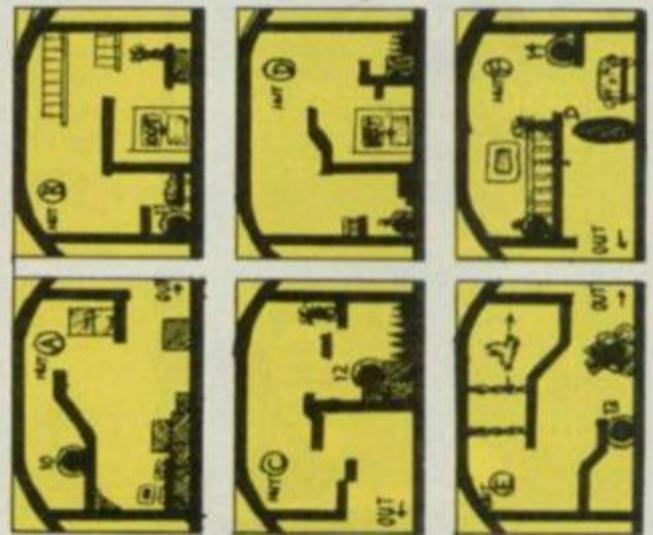
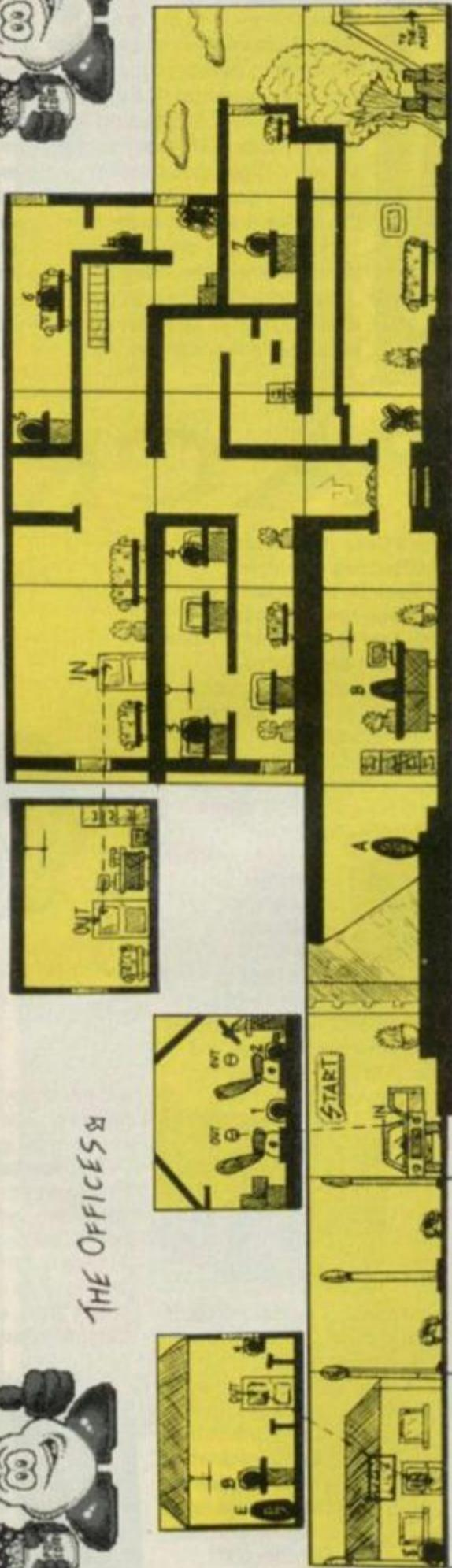

STUDIO MAZE

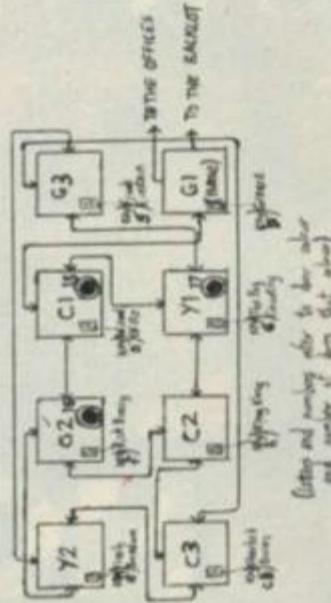

KEY

- STUDIO KEY**
- 1-38 OBJECT
 - HIDDEN OSCAR
 - A-P CHARACTER
 - TOWSER
 - MUNCHKIN
 - PACKING CASES
 - ROCKS
 - SPIKES
 - WATER
 - CLOUD
 - FAN
 - CHANDELIER
 - BARRELS
 - LIFT
 - BAD GUYS
 - PARROT
 - WINDOW
- ANYTHING ELSE IS JUST SCENERY (OR, PROBABLY)

OBJECT KEY

- 1 - SHOES
- 2 - HAND
- 3 - HEAD
- 4 - PANTOM
- 5 - POTION
- 6 - HAND
- 7 - BALLOON (DEFLATED)
- 8 - FOOT
- 9 - BANANA BUTTIE
- 10 - LEATHER JACKET
- 11 - LEG
- 12 - BOUNCY BALL
- 13 - SPANNER
- 14 - DAGGER
- 15 - WOODEN MALLET
- 16 - DICTIONARY
- 17 - LEG
- 18 - ARM
- 19 - BUNCH OF FLOWERS
- 20 - RUBBER GLOVES
- 21 - TOWEL
- 22 - DOLLAR
- 23 - DOLLAR
- 24 - DOLLAR*
- 25 - MARKED CARDS
- 26 - BIKE PUMP
- 27 - PARROT SMACK
- 28 - ARM
- 29 - LOVE LETTER
- 30 - ARREST WARRANT
- 31 - BODY
- 32 - GUNPOWDER
- 33 - LOLLIPOP
- 34 - CLOCKWORK HEART
- 35 - DENIMATOR
- 36 - MEDAL FOR VALOUR
- 37 - BRAIN
- 38 - FOOT

(*I don't like Dollar 'as they all a copy version of Guinness' coming 'in L'Annuaire')

(Don't forget - the objects won't all be there straight away)

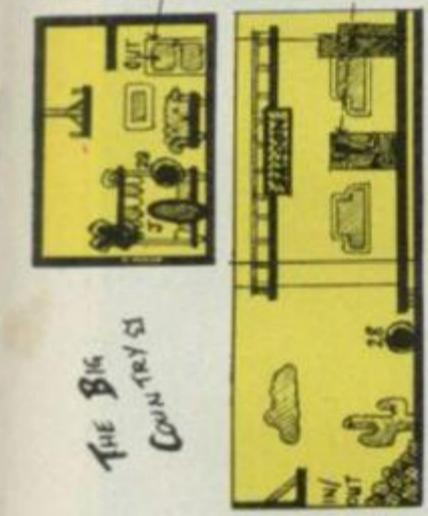
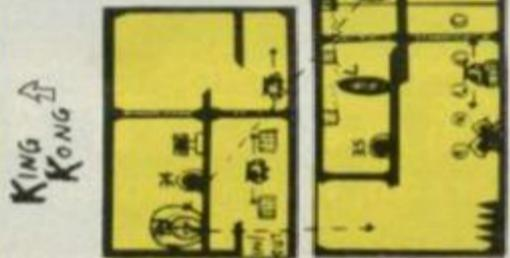
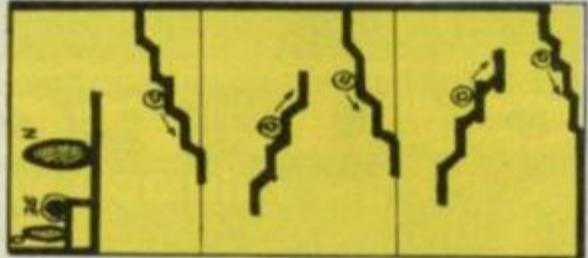
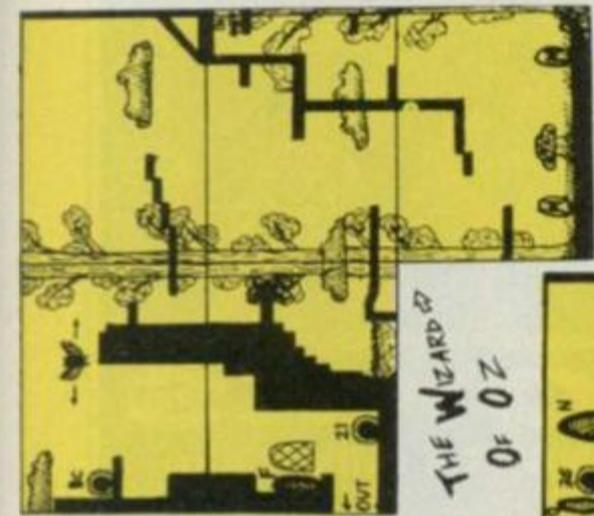

THE SETS



- CHARACTER KEY**
- A - Doorman
 - B - Pippa
 - C - Tarzan
 - D - Capt. Bearby
 - E - Gressy Lil
 - F - Dorothy
 - G - Corpse
 - H - Biker
 - I - Sindy
 - J - Sal

- KEY OF OZ**
- O - Open Wizard Of Oz
 - b - " Grease
 - c - " Sherlock Bones
 - d - " Flash Bedroom
 - e - " Big Country
 - f - " Rick Bracy
 - g - " Frank Einstein
 - h - " King Kong
 - i - " Red Herring (a piece)
- K - Rick Bracy
L - Ming
M - Cowboy
N - King Kong
O - Munchkin
P - Frank Einstein
- (Remember, they won't all be in the same place by the time you get the script.)

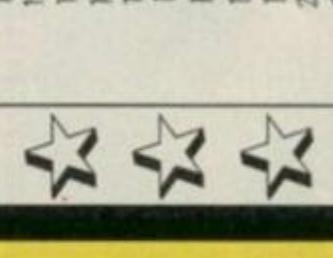
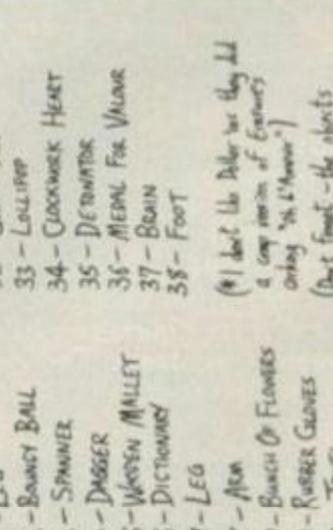
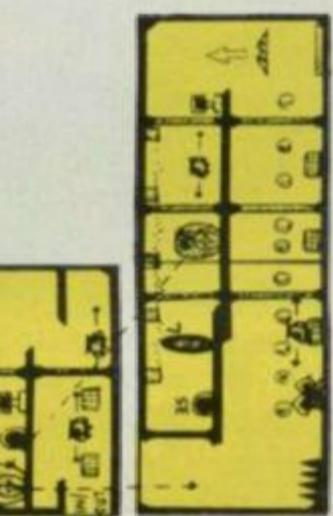
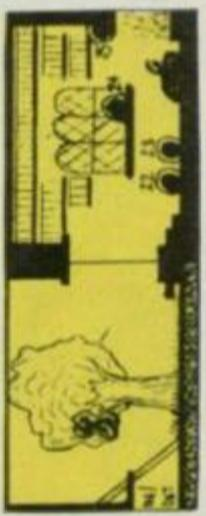
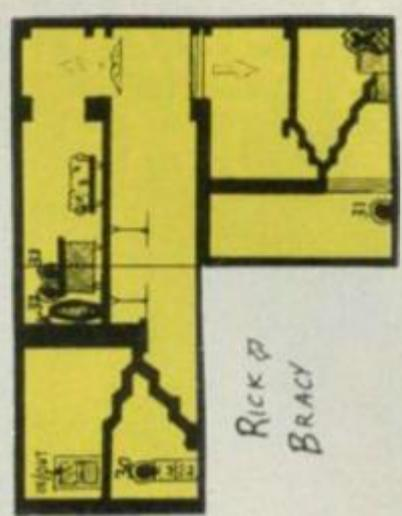
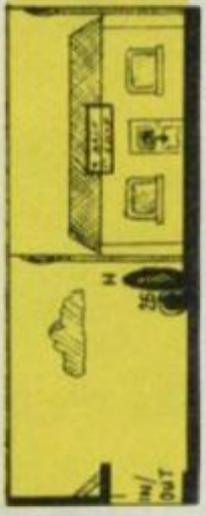
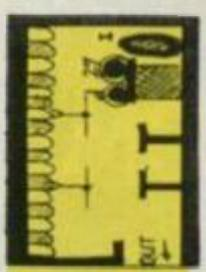



SEYMOUR GOES TO HOLLYWOOD THE COMPLETE SOLUTION

That was the map, here's the complete solution...

In limo, get shades and hand, out, R, past doorman, R to lift, keep going right to the first maze screen (base). Drop objects, L, get mallet, L, get dictionary, R, in, just take the dictionary back in, L, L to Pippa the receptionist, give her the dictionary, R to base, R, R past base. Go up into the tree village and collect everything from the huts (jacket, ball, leg, spanner, key a). Take them all back to base and leave them there. Take only the spanner in and go L to lift. Use spanner in the lift, U and collect everything from this area (head, pompom, potion, hand, key b, balloon) and take them all back to base and drop them. Open door on base screen with key b, take jacket and pompom and enter Grease set.

Give jacket to biker, get pump, R, give pompom to Sindy, get snack and key d, L, L, out, take key a and go left. Open door, enter Oz set, D, avoid munchkins, L, U, L, U, L, get key c and avoid bat, D, out, Lx3, open door with key c, r, l, in, take key d, Lx2, in, open door and enter Flash set.

Time your way past the choppers and get heart, out, L, R, in, drop stuff and take snack, pump and balloon R to the village. Take snack up to hut E and lure parrot

out by dropping snack so that it flies to it. Lure it L and into hut F, get dagger and key e, D, drop stuff, take balloon and pump to riverbank and use them. Avoid fire in balloon and, when across, enter hut, get gloves and key f. Go out, take gloves, key f, flowers and arm back across the river one at a time. You'll have to hold the pump and balloon as well. Take everything back to base, take key c and go Lx4.

Open door, enter Sherlock set, use gloves to pick up one dollar and cards. Leave set, in, R, in, in, drop stuff, back L, Lx3 to get other two dollars. Back in, R, in, in to base, drop, take keys e and f left, L, open door and enter Rick set.

Get warrant, take lift D, get body, U, L, out, R, in, drop, take key e L. Go R, open door and enter Country set. Get arm, out, back in, in to base, pick up warrant, cards and a dollar with gloves. Do this by picking up the gloves first so that you can drop after you pick up the last item. Take warrant, dollar and cards L, R, enter set, R, into saloon, R, arrest cowboy, take stuff back L out of set, back left, in, enter Rick set, R, lift U, L, give evidence to Rick, get gunpowder, back out of set, back R, into base, drop, L, R.

Enter Country set, R, into

saloon, R, U stairs, L, through middle door, talk to Sal, get love letter and go all the way back out of the set, L, in, enter Rick set, R, U, L, give letter to Rick, get lollipop, R into base. Take lollipop and a dollar in, L all the way to the road, cross road, get foot, into Greasy Lil's and buy buttie. Take lollipop, buttie, foot and key g back R across road to base. Drop, take key g and ball L, Rx2, open door and enter Frank set. Give bail to Towser, L, U, L, D and get key h. Back U and R out of set, L, in, in, take only key g and go Lx3. Open door, back in, R, into base, take mallet, buttie and dagger Lx3.

Enter Kong set, hit barrels on your way to the top, give buttie to Kong, cut maiden's ropes with dagger, get medal, back D and out. In, R, into base, take all bits of Frankenstein (head, body, arms, legs, hands, feet) and gloves and dollar. This'll take about four return trips. Go L, R, R to Frank set, enter Frank set and drop all the bits under the table. Put dollar in meter, make sure you've got gloves on and pull both switches, pull them back when Frank's alive, go R through gap, get brain, R and out, L, in, into base, take brain, heart and medal L and enter Oz set.

Follow set around and give everything to Dorothy. Get towel,

out into base, take towel and potion L, L, in, enter Flash set, U to teleport. Drop towel in front of teleport and then flick the switch on the terminal. Don't teleport yourself until the towel's gone. When teleported go R, U in lift, L, past Ming without stopping (you'll turn visible). Get detonator, back R, teleport back, out of set, L, R, into base, take flowers, detonator and gunpowder in and left through offices. Give flowers to Pippa, get key, R to lift, U to top floor, L, open red door, enter office, drop gunpowder by safe. Go out and use detonator, back in, get script and that's it.

Oh, apart from the fact that you now need 16 actors. So you've got to find all the Oscars. I can only find 13 of them after many hours of eyestrain and expostulations. Take an Oscar and a script to every character in the whole game. That includes Pippa, the doorman, Greasy Lil, Tarzan, the biker, Sindy, captain Beardy, King Kong, the maiden, Ming, Frank Einstein, the cowboy, Rick Bracey, Sal, Dorothy and the corpse. That's all. Go to it!



PRACTICAL POKES

I'm a person, not a number. See! I've got a zit! JON NORTH tells it like

A few of you wrote in asking why I've never had my photo published. My usual reply is the embarrassingly unoriginal "I don't like cameras", but if the truth be told, I've got a zit on my forehead which I don't want to show the world.

A*WHOLE LOAD OF ANONYMOUS STUFF

This month's column has been overrun by anonymous hackers Gerard Sweeney and Jamie Murray's latest attempt at world domination, so I've got to make them Hackers of the Month again. This is all re-release stuff that's just come out on compilations.

AMC Part 1

```
10 REM AMC by Hackers Anon
20 CLEAR 29999
30 LOAD ""CODE: LET
A=25400
```

```
40 READ B: IF B=999 THEN
RANDOMIZE USR 25400
50 POKE A,B: LET A=A+1:
GOTO 40
60 DATA
33,65,99,34,43,248,195,0,248
70 DATA 62,183,50,162,159:
REM INFY LIVES
80 DATA 175,50,40,176: REM
INFY TIME
90 DATA 62,X,50,24,120: REM
X=GRENADES (1-255)
100 DATA
175,50,67,120,61,50,63,120:
REM START FULLY ARMED
110 DATA 195,0,238,999:
REM END MARKER*
```

Part 2

```
10 REM AMC by Hackers Anon
20 CLEAR 29999
30 LOAD ""CODE: LET
A=25400
40 READ B: IF B=999 THEN
RANDOMIZE USR 25400
50 POKE A,B: LET A=A+1:
```

```
GOTO 40
60 DATA
33,65,99,34,57,248,195,0,248
70 DATA 62,183,50,162,159:
REM INFY LIVES
80 DATA 175,50,40,176: REM
INFY TIME
90 DATA 62,X,50,69,106: REM
X=GRENADES (1-255)
100 DATA 62,X,50,69,108:
REM X=SHIELDS (1-255)
110 DATA 195,0,238,999:
REM
```

HERO QUEST

```
10 REM Hero Quest by
Hackers Anon
20 CLEAR 24575
30 LOAD ""CODE 16384
40 LOAD ""CODE
50 POKE 34151,182: REM
INFY MOVES ALL PLAYERS
60 LET MC=USR (28030)
```

SUPERTANK SIM

```
10 REM Supertank Sim by
```

```
Hackers Anon
20 CLEAR 24575: LOAD
""CODE
30 POKE 24626,232: POKE
24627,253
40 LET A=65E3
50 READ B: IF B=999 THEN
RANDOMIZE USR 24576
60 POKE A,B: LET A=A+1:
GOTO 50
70 DATA 175,50,76,162: REM
INFY LIVES
80 DATA 195,69,144,999:
REM
```

Gerard and Jamie were the only ones this month to send me something worth printing. Come on you lot, surely someone out there can do something about this? Have a think about it then get back to me, Jon North, at PP, YS, 30 Monmouth Street, Bath, Avon BA1 2BW. See you in the scrolly.

DR BERKMANN'S



CLINIC

Got a gamesnag? See a specialist!

Ah, that looks nasty. Very nasty. Nurse, fetch my surgical implements. The very blunt ones.

ROBOCOP 2

First under the knife – stop screaming, for Pete's sake – is Christopher Key, who couldn't find the lift switch on Level Two of this mildly disappointing film tie-in. "Why bother looking?" I helpfully replied. But **Richard Caine** has applied his giant brain to this question (*Are you sure that shouldn't be 'brain'?* Ed), and Brian has come up with this. (Sorry, Ed)

"From the start, go right destroying any crates and killing bad guys until you reach the door. Go through and then back through again. If you get killed now, you will start from this door and not the beginning. Go left and jump

onto the first conveyor belt, then onto the one above it. When you reach the end of this, jump onto the belt to the right, then up to the one above. At the end of this, jump straight up onto the ledge. Up again, across the gap and onto the next ledge. Face to the right, straight up twice, then jump right, and then straight up twice again. Jump up and right twice, and you should find yourself on the top conveyor. Jump off the end and you'll fall onto yet another belt. Jump right, over the gaps and then right off the last belt onto solid ground. Walk right a little way until you see a switch on the back wall. Shoot it once to activate all the lifts. To get back, just go along the bottom conveyors. I hope this helps!"

Yes, me too, Richard. Thanks also to **Jonathan Fitt** on that answer. In fact, Richard goes on to remind me that his boffo tip for *Mercenary* in the same ish (71) about the triangular doors only works for *The Second City*, and to ask a question of his own, to wit: "Does anyone know a way to stop the brill *Kwik Snax* crashing after 80,000 points? Haylp!" Any ideas, Clinicians?

RENEGADE

Level Three's Big Bertha was the problem here for Robert Stone. Apparently he often has run-ins with females of what might be described as substantial proportions.

Hey, Robert, this is a family show! Still, **Gareth Surgenor** knows what's what, who's who, and when's why's wherefore, which probably takes a bit of practice. Gareth?

"Right, Big Bertha. First

kill all the teeny ladies until Big Bertha moves out of her hidey hole. If she is on your right, then move down and left until you hit the bottom of the screen. Move to the bottom right if she's on your left. Keep on moving backwards until she hits the bottom. Stop – she'll run at you now. When she's about 3-5cm away, jump-kick her face and she'll fall. If you're on the bottom left, now move to the top right and again continue going backwards 'til she runs, when you promptly kick her in the face. Carry on doing this until she hits the floor for the last time and – ta da, you've done it.

By the way, on the next level, the boss has a gun, so watch for the bullets. Get as close to him as you can and he won't shoot, only kick and punch." Oh, well that's all right then. (Ooof!)

BLINKY'S SCARY SCHOOL

Crazy name, crazy game. Being driven crazy by it all is our old chum Daz Ellis. Daz can get to the room where it's completely black, but can't jump over the gap to get the torch. Step forward the fearless **Alan McDonald**, who proffers this excellent advice:

"Walk right until Blinky falls off the first platform, and the second he lands on the second platform, jump right. You should have jumped over the gap!"

Top hole and spiff-ho, as my old grandma used to say after the shipping forecast. Badge on the way, Alan...

CHUBBY GRISTLE

Ah, you were wondering where **Richard Swann** was, weren't you? He's a bit cross with me

this month (for calling him Dicky again, probably) and asks "Do you ever read the 'gossip' that appears at the start of my letters?" Of course I do, Richard, it's just the rest of it I don't bother with. Ha! Ha! Ha! Still, he knows the answer to Mr J "Formal" Turner's gamesnag, for "Formal" had collected all the food, arrived at Greasy Joe's and eaten everything there. Not surprisingly, he wanted to know what to do next. "Go to the 'weigh-in' room," suggests the Swann, "where, provided you've eaten everything, you'll break the weighing machine and explode from overweight!" Hmm, delicious. More stuff from Richard, I suspect, next month.

HAYLP!

A quick snatch of snags to keep you going:

Richard Mitton: "In *The Happiest Days Of Your Life*, what do you do with the passage key, and is there anything in the headmaster's study?"

Alex Marsh: "How do you get into the yellow grass in *Slightly Magic*?"

Carole Johnson: "In *Supercop*, what's the Level Two code for the computer Armageddon and where can I find it?"

Harry Frith: "In *Marsport*, I'm stranded in the third games room on Tarr level, Sector G. Where's the key to open the exit door to Sector C?"

Remember, send all your snags, tips, solutions, biscuits and old yogurt pots to Dr B's Clinic, YS, 30 Monmouth Street, Bath BA1 2BW. I'll be waiting by the letter box. Yowsah!

ALIENS

Spooky YS covergame, ahoy! This one had even James hiding behind the sofa. (*What do you mean, "even James"?* Ed) Here's a map, solution and tips – all from the chewed black biro of **James Pope**...

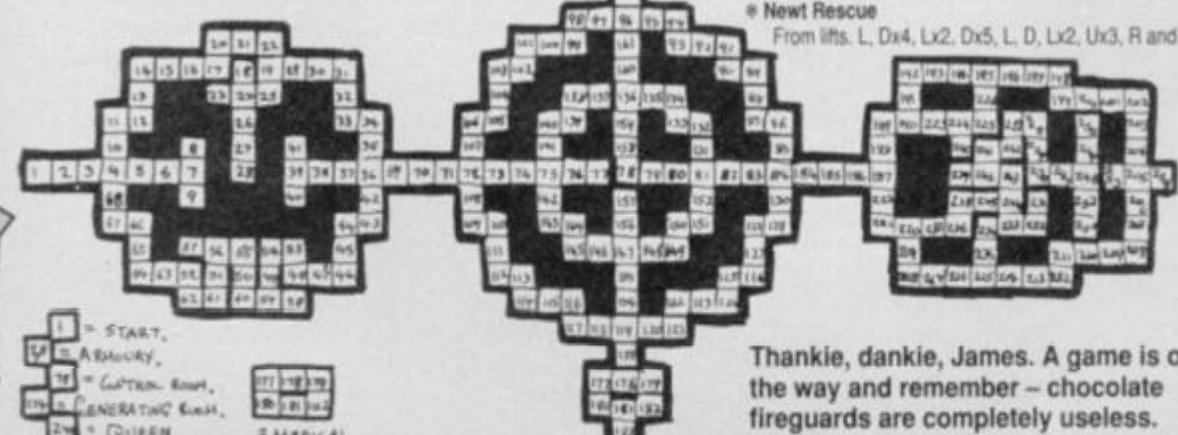

KEY
L = Left R = Right U = Up D = Down

• APC Rescue
From marine one (Drake). Rx2 (you should see Frost), Rx2 (should see Dietrich), R, D, R, D (should see Crowe), D, Rx2, Dx2, Rx3, Dx5, Lx2, D, R and enter APC.

• Newt Rescue
From lifts. L, Dx4, Lx2, Dx5, L, D, Lx2, Ux3, R and Newt

will appear and follow you.
And now the codes...

Level	Code
1	7324G
2	2727H
3	1506E
4	5761H
5	0640C
6	0663F

ANDELEY ANDELEY

Time to get out of here. Tune in next month for more thrills, spills and bellyaches with Linda B's little shop of tips. Send your maps, tips, hints and unwanted Christmas presents to me, Linda B, at the YS Tipshop, 30 Monmouth Street, Bath, Avon BA1 2BW.

Thankie, dankie, James. A game is on the way and remember – chocolate fireguards are completely useless.

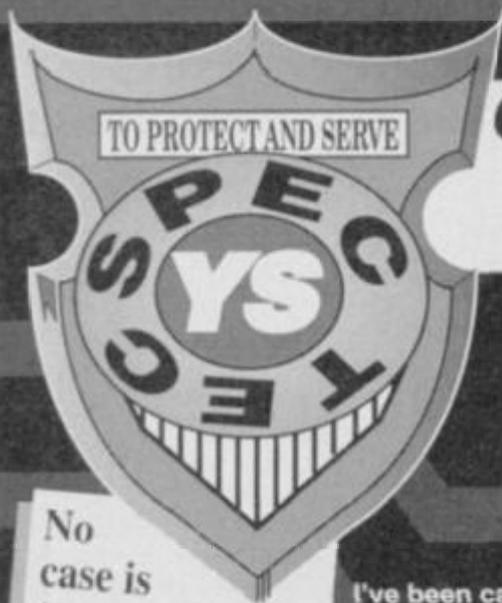

Got a problem? Get it solved! With
ADAM WARING



SPEC TEC

No case is too tough for Spec Tec, apart from the mystery of the missing wig, that is...

I've been called to the scene of the crime this month readers and it's a pretty tough nut to crack. It's an important case, though, and I stand to make lots of moolah if I can solve it.

Someone broke into the City Hall and stole the Mayor's wig. He's bald as a coot and refuses to go outside without it firmly stuck on his bonce.

But how did they get in? I just can't figure it out. I wish somebody would get that window fixed, it's getting kind of chilly in here, and somebody could get hurt on all that broken glass.

And what's the reason behind the crime? What would anyone stand to gain from stealing the Mayor's wig? I wish they'd keep the noise down outside, I can hardly think. It's election day and all the candidates are riding around with loud-hailers. All except the Mayor of course!

Just look at them. There's Jones, from the oppositon in his open-topped Limo. Hmm, I wonder why he's got that funny-looking cat on the seat next to him. Must be some sort of mascot, I s'pose...

RESET YOURSELF

I want to put a reset switch in my old Speccy but the problem is I don't want one that cuts the power supply. The reason for this is because I have a +D interface which stores its DOS in its RAM. So I'd need to load it in again every time I reset the Speccy. I also have a +2 and the reset switch on that operates leaving the DOS intact.

I did some research and found out that pin 26 of the Z80 is the reset input for the CPU and that if set too low it will set the program counter to zero. Would it be possible to connect it to the 0 volt input of the Z80 with a push button switch so that it will operate like a +2 input switch? I would be most grateful for any help you can give.

**Michael Tang
Leicester**

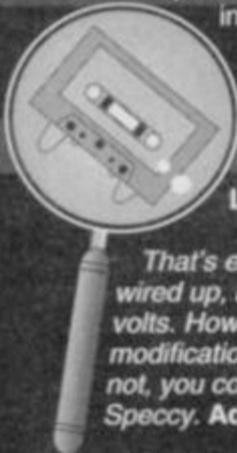

That's exactly how the +2's switch is wired up, by pulling the reset line to zero volts. However, if you're to attempt the modification yourself, be careful. If you're not, you could end up with one dead Speccy. Ad.

WHAT'S THE SCORE?

I'm just about to finish my own game but I need to add a few finishing touches. First I saw how to do a high score table in machine code, but how do you do one in BASIC and keep the scores in memory? And how can I put a cheat in my program - again in BASIC? I tried this at the start of the game. You enter the name like this:

```
20 INPUT "Enter your name: ";a$
30 IF a$="CHEAT" THEN LET
lives=99
```

But it doesn't work! Please help me!
**Darren Wells
Sutton-on-Trent, Notts**

Make sure that you're not resetting the lives to the normal amount after the cheat. Set the lives before you check for a cheat, so modify line 30 to read:

```
30 LET lives=3: IF a$="CHEAT" THEN
LET lives=99
```

Get rid of any other line that sets the number of lives you have.

For a high score table you need to write a little routine that compares the score with the highest scores so far, and inserts it into the proper place in the list. Something, in fact, a little like this:

```
10 DIM h$(5,10):DIM h(10): REM Save
space for five high scores, each up to 10
characters in length
```

...Your game goes here...

```
1000 REM High score subroutine. a$
contains the player's name, score is their
score.
```

```
1010 FOR x=1 TO 5
1020 IF score > h(x) THEN GOTO 1050
1030 NEXT x
1040 RETURN: REM No high score!
1050 FOR y=5 TO X STEP -1: REM We
have a high score. First shuffle
everything else down
1060 LET h(y)=h(y-1):LET h$(y)=h$(y-1)
1070 NEXT y
```

```
1080 LET h(x)=score:LET
h$(x)=a$:REM We've got to the right
place now, so insert the new high score.
1090 RETURN
```

Hope that the game goes well. You should be able to get in the high scores now, you dirty, rotten low-down cheat! Ad.

PLAY THE GAME

I am about half way through learning BASIC. I know enough to make some types of game, but pokes are beyond me so I use other people's.

I need to know how to get the music to play while the computer gets on with something else. I also need to know how to save a game keeping the variables at whatever point they are. I can save a game mid-way, but not the variables.

You wrote in the July issue that there are 21 UDGs. My manual says that there are only 19; 'A' to 'S'. I own a Speccy+2.
**A Greenwood
Accrington, Lancs**

Although the Plus machines have the facility to output sound using the built-in sound chip, they can't play music while the computer gets on with other things, such as controlling the game. This is a pity cos the sound chip is more than capable of looking after itself.

The only way (I know of) to get the computer to play music and do other things at the same time from BASIC is to play the tune one note at a time through the program's main game loop.

Each note has to be played very quickly so it doesn't slow the computer down too much. As long as the game itself runs quite quickly it can sound reasonably OK, but by no means terrific.

This said, I think that the only real way round the problem is to resort to machine code. What you really need is an interrupt-driven music driver program that sends data to the sound chip without having to wait while it plays the sound. Unfortunately, I haven't got one. But if anyone has come up with a short program that can be used from BASIC, I'm sure we could come to some arrangement with regard to an extra-special Special Investigation prize!

Saving a program to tape automatically saves all the variables with it. Be careful though, and make sure you don't RUN a program whose variables you want to keep.



TAXING TOUGHIES TACKLED

TOTAL RECALL

In the October ish there was a request for a 48K program to recall a screen from memory. There is a simpler method to the one you printed for 128K users.

Built into the Plus computers is a RAM disk that can be used to store screens, code or BASIC programs. This is a good place to temporarily 'hide' screens:

```
10 LOAD "filename" SCREENS :REM
Load the screen
20 SAVE "m:filename" SCREENS
30 CLS
40 PAUSE 0: REM Wait for a key press
50 LOAD "m:filename" SCREENS
```

This saves the screen to the RAM disk and then loads it back again. You can get rid of the file with ERASE "m:filename".

Ian Hewett
Swansea

Thanks, Ian. You may find something 'appearing' on your doormat soon! Ad.

DETECTIVE WORK

In YS72 you asked whether there was a way to detect whether a Spectrum was in 48K mode or not. There are two ways to do this. The first, very simply, checks the ROM; there are a few differences between 48K and 128K Spectrums:

```
IF PEEK 5440=65 THEN PRINT "This is
a 128K Spectrum"
```

or

```
IF PEEK 5440=83 THEN PRINT "This is
a 48K Spectrum"
```

Unfortunately this routine returns a 128K result on a 128K machine in 48K mode. However, we can get round that using the second method that you explained by using the 128K memory banks. We must, however, make sure that the stack is not in the banked memory, between addresses 49152 and 65535.

```
10 CLEAR 49151
20 POKE 49152,1:POKE
23388,17:POKE 49152,0:POKE 23388,16
30 IF PEEK 49152=1 THEN GOTO 100
40 IF PEEK 49152=0 THEN GOTO 200
100 REM put 128K routines here...
200 REM put 48K routines here...
```

This routine should work at any time, but bear in mind that the byte that was at address 49152 will be lost.

Secondly, I'm afraid that the tips for disabling the EDIT key by John White do not work on either a Spectrum +2 or a rubber-keyed 48K Speccy. Fortunately I have discovered an alternative form of program protection, namely a way to hide BASIC programs.

The following routines only work in 48K, and cannot hide a program in 128K mode. (You can use POKE 23386,0 to make the program crash if you're in 128K mode.) Enter the first line with a line number below 256 and type:

```
POKE 23755,255
```

The program will disappear! You can make it reappear again with:

```
POKE 23755,0
```

If you use this method in your BASIC program, the program will run, but will stop after any GOTO, GOSUB or RETURN statements. To get round this, temporarily disable the hiding routine (POKE 23755,0).

Richard Swann
Camberley, Surrey

That's a neat tip, kid, and that means you get a neat tip - in the form of a Special Investigation prize! Watch your mail box! Ad.

ON TAPE

I've just read Spec Tec in the December issue of YS and came across a letter from D W Harding concerning an external tape deck for his +2A. I have a +2, but think this applies to both machines.

Disconnect everything from the computer and undo the screws to open the machine. Inside there is a white connector which houses 5 wires. The black and red wires take power to the deck, the blue wire is the ear signal (load) and goes to the tip of a plug connected to the ear socket on the external tape deck. The white wire is to the mic signal (save) and goes to the tip of a plug connected to the mic socket on the external tape deck. The brown wire is the signal earth and goes to the base of both plugs.

I use a stereo jack plug with two colour-coded mono plugs coming from it and a stereo socket with all leads inside fitted to a hole drilled in the side. (This is the same as the +3.) It works perfectly.

You have to disconnect the plug when you want to use the built-in deck. Be warned though: this will invalidate your guarantee and I won't take responsibility for any damage caused through wrongly disconnected wires!

A Park
Andover, Hants

Thanks for another Special Investigation solved!

If your computer is still under guarantee, then I suggest you get the internal tape deck fixed rather than making holes in the side of your Speccy! Ad.



Y'see, this command clears them all. If you want to save the game to continue at a certain point, following the filename with the LINE command does this. Alternatively, when reloaded, the program will continue immediately after the line it was saved at. Like this:

```
1000 SAVE "program" LINE 100:
REM When loaded, program will
start from line 100, with all
variables intact
or
```

```
1000 SAVE "program"
1010 REM When loaded, the
program will continue from here
with all variables intact
```

You can also save arrays separately to tape, which is great for saving things like high scores without having to dump the whole program to tape. If you wanted to save everything in the 'h' array you'd use the format:

```
SAVE "filename" DATA h ()
```

If you want to save all the information about the current state of play onto tape, such as lives, score and whatever, one way to do it would be to copy all the information into an array, save that to tape. When you reload it,



you can then copy all the info from the array back into the variables.

There are 21 user-defined graphics, but only in 48K mode. In 128K mode you lose 2 UDGs to make way for a couple of extra commands, PLAY and SPECTRUM. It's a bit of a bodge job, really. Ad.

STOP IT

I have a Speccy +3 and I also have a very horrible brother who keeps breaking into my programs and messing them up. I know that you can poke the 'break' key to make the computer crash when it's pressed, but how can I stop the 'stop' statement from working?

I would be grateful for any help you can give me.

Mark Fleming
Kirkcaldy, Fife

I suggest you take the problem by the horns. Tackle it at its roots, Mark. What's the real problem - your brother, that's what. I know a guy, 'Crusher' Mahoney, who can sort out your problem once and for all...

But if that will get you in trouble with your Mum, then maybe just preventing 'stop' from working isn't a bad idea. I'm sure that there was a way, but I can't remember how. Tell you what, if anyone knows how, there'll be a handsome prize in the post! Ad.

JUST A NOTE

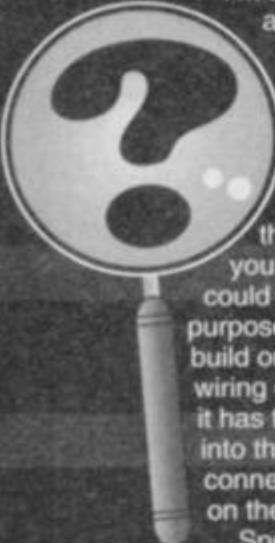

I'm a keen musician and I own a Speccy +3 with a Yamaha PSS 680 keyboard. It mentions in the manual putting the letter 'Y' before the notes in a PLAY statement to send it to the keyboard. Please could you clearly explain how I could build a lead for this purpose as I'm unsure how to build one because I don't have a wiring diagram. I only know that it has to have an RS232 to go into the Speccy and a DIN connector to go into the MIDI IN on the keyboard. Help!

Speccy +3 owners may be interested to know that I've discovered a couple of things which are weird! Type COPY RANDOMIZE and press ENTER. Before the Speccy has time to realise you've made an error by going 'beep', immediately hold down the keys 'Z', 'C', 'P' and 'L', and the Speccy greets you with a message. Brill, eh?

Craig Daines
Yapton, West Sussex

The RS232 socket on the back of the Speccy doubles up as a MIDI OUT socket too. You will need to construct a cable with a Telecom-style plug on one end, and a 5-pin DIN plug on the other. The lead should be wired as follows. Ad.

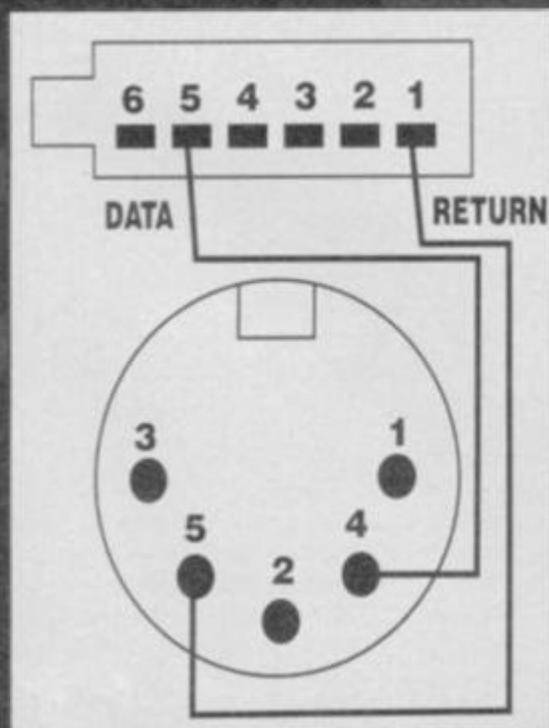

FOND OF RUBBER

I need some advice. For the last 8 years or so I have owned a Spectrum computer of some description. I fondly remember those rubber keys, but the need to upgrade came.

My main reason for the purchase of my new Speccy +2A was for the better quality of the keyboard: I want to use the Speccy as a word processor. Up until now I have been managing with an electronic typewriter, put as it's a typewriter/printer, why not take advantage of word processing facilities?

Thus, my questions are:

● Would Tasword +2 and a Datel Inter Printer work with my Panasonic KXR193 typewriter? (It has a parallel interface adaptor.)

● I was extremely disappointed to find that the +2A keyboard is smaller than the industry standard keyboard. The thought came into my mind that the keyboard may not be as durable as I was lead to believe. Am I correct?

● As my computer takes up valuable space on my desk, it is relegated to sitting on top of my telly when not in use. Is this safe?

K Hunt
Croespenmaen, Gwent

Glad to see you're still faithful to the cause.

● As long as the typewriter has a Centronics parallel interface (and it should do; it's the industry standard) then you should be able to use it directly linked to the Speccy. There's no need for an extra printer interface, as the +2 has one already built in. All you'll need is a cable to connect the two together which should be available with locally or through the adverts in YS. Tasword +2 is a fine choice for a word processor.

● The +2 keyboard is quite small, but should be able to take a fair pounding before it gets worn out.

● You shouldn't put anything magnetic on top of a telly as it can distort the picture. I don't think it will do any serious harm, though. Ad.

GETTING INTO PRINT

I need your help urgently. I am a student at a secondary school in Sheffield and am moving into the 5th year. I can't bear to be away from my Speccy for too long so help me by answering the following questions:

- How much is a printer for a +2?
- Is it worth paying the extra for colour?
- How do you print from the Speccy to the printer?
- How the heck do you get a program to run automatically when you load it instead of having to type 'RUN'?
- Why doesn't Andy give you a rise?

Andrew Cain
Sheffield

● Printers start at around £130 for a very basic model, but can cost many times that.

● Depends what you're going to do with it. If all you want to do is print out letters, then no, it's not.

However, if you're a bit of a dab hand with art packages, then you'll have the luxury of being to print out in colour.

● Easy! The LPRINT command sends text to the printer in the same way as the PRINT command does on screen. If you would like a listing of your program printed out then use the LLIST command.

● You get the Spectrum to automatically run from any line on your program. Say you wanted it to run from line 10 you would save the program as follows:

SAVE "program" LINE 10

● Good idea! I'll ask him:

Andy: "Yo, Ad my man."

Me: "Been a long time, Andy. And I think it's time you showed a little gratitude. I'm talking about my rate."

Andy: "You're unbelievable!"

Hmmm, I don't think that went down too well. Ad.

SAVE YOURSELF



Could you help me by telling me how to save something onto disk using a +3. I've tried everything, I've looked in the book and done everything they said. I buy your magazine every time it comes out but it's never told me how to save something.

Gareth Wilson
Huntingdon, Cambs

Before a disk can be used you will first have to format it. This sets up the disk and makes it ready to be able to hold information that the computer can read or write to. Use the command:

Format "a:"

Programs can then be saved with:

SAVE "filename"

It's as simple as that!

YOU KNOW WHERE TO FIND ME

I've been racking my brains for hours and I just can't figure it out! What I'd give for one solitary clue! I'm obviously up against a very clever and mysterious crime organisation.

What's this? Ah, the Mayor. Oh, apparently I'm off the case. He lost the election to Jones and so can't afford to pay me. Pity, he was a damn fine chap.

But that leaves me with (ahem) a little cash-flow problem of my own. Looks like I'm going to have to rely on another sackful of your problems to sort out, to get me by for another month.

The address is Adam Waring, Spec Tec, Your Sinclair, Future Publishing, 30 Monmouth Street, Bath BA1 2BW.

Don't enclose SAEs with your letters, though. I'm a hard working guy and don't have the time to reply personally to your problems! Sorry and all that.



SPACE MUTANTS ARE INVADING SPRINGFIELD!

That's right man!
A buncha slimy, horrible, totally gross and putrid monsters are taking over the bodies of the people who live here and they wanna build a weapon that's gonna take over the entire planet!

PRETTY COOL HUH?

Anyway, yours truly is the only one who can see 'em! I've gotta spray-paint things, get radical on my skateboard, use my trusty slingshot, and in general behave like a nuisance, man. Plus, with evil dudes like Nelson the bully and Sideshow Bob getting in my way, it's a good thing I've got the rest of the Simpsons to help me out!

So if you're a decent person a patriot, and somebody who cares about this sorry planet, you'll do the right thing.

BUY THIS GAME!
Thanks man.



MATT GROENING



IBM PC
AMIGA
ATARI ST
SPECTRUM
COMMODORE
AMSTRAD



Acclaim
entertainment, inc.

ocean

TOTAL!

It's 100% Nintendo,
it's on sale now...



Wowee! A mag all about Nintendo - and nothing else! It's fab 'n' brill 'n' wonderful (and it's got me in it!)

January 1992
Issue 1
£1.95

NEW!
You've never seen a mag like it...

TOTAL!

100% FOR NINTENDO PLAYERS
A totally independent mag from Future Publishing

NINTENDO EXPLOSION!

Our total NES and Game Boy action will blow you away!

WHAT A HOOT!
CHORTLE! - As we show you the best games in the shop!
SNIGGER! - As our tips help you finish Super Mario Bros!
GRIN! - When you win one of our three superb Game Boys!
SMIRK! - When you're TOTAL! Gameplayer Champion! And...
SMILE WEAKLY - As we try desperately to be funny

WOWZER! 84 pages of 'total' Nintendo action!

Future Publishing
Your guarantee of value

9 770964 935007



Got an NES or a Game Boy?
This is the *only* mag for you,
because it's the *only* mag
dedicated to Nintendo games.
(And 'cos it's brill too!)

...and you've never
seen a mag like it!

Look out - he's back!

PAPERBOY

No window is safe. No fence is too high. The paperboy is determined to deliver the paper to his subscribers any way he can. Tossing papers left and right, riding in three directions, jumping anything, this free-wheeling carrier visits more neighbourhoods and houses, faces more targets and obstacles, in more vivid colours than ever before. Plus, rad stunt riding and BMX tracks in bonus rounds. Choose to ride as either Paperboy or Papergirl too!

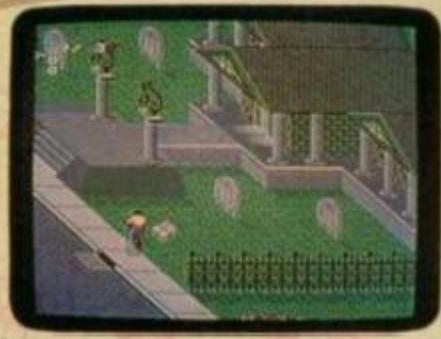

Copyright 1991 Tengen Inc.
Paperboy 2 is a trademark of Tengen Inc.
All rights reserved



MINDSCAPE

For your local dealer, contact **Mindscape International Ltd**, The Coach House, Hooklands Estate, Scaynes Hill, West Sussex RH17 7NG. Tel: 0444 831 761

BIG NOSE'S AMERICAN ADVENTURE

FIVE THINGS WITH BIG NOSES

- Barry Manilow.
- Concorde.
- Frank Bough.
- Pinocchio
- The Hoover dam

CodeMasters/£3.99 cass

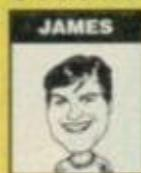

Oh dear. CodeMasters have gone funny again. Not content with fiddling around with slugs and eggs, they've gone and got themselves involved in time tunnels. You'd think they'd know better, wouldn't you?

The time tunnel they've just started mucking around with has apparently whisked a caveman called Big Nose from pre-historic times to Manhattan in the twentieth century.

As well as the Cro-Magnon dude, there are also loads of ancient style animals trapped in the present day. Big Nose has got to travel along loads of platforms to rescue them and, along the way, there's fires, policemen and bombs to avoid.

It all sounds slightly implausible, especially if you're old enough to remember those Jackanory stories about Little Nose and Big Nose (two cavemen, incidentally), told by a Scottish guy with a massive sweater and an equally massive beard.

Anyway, as you rush around the platforms, you have to keep jabbing away at the fire button cos the place is crawling with things that keep trying to destroy you. To get maximum fire you've got to keep flicking the fire button as quickly as possible, you can't just hold down the button. This gets a tad tricky when you're close to the edge of a screen and you've got to move onto a new screen which might just be covered with nasties.



Some of the jumps demand split second timing. Others demand £100,000 in used notes and a helicopter to Brazil.

in the air, so that makes things much easier.

Sound and graphics in *Big Nose* are pretty much what you'd expect from a good Codies' game. You know the kind of thing - nice big sprites and diddeley-doo musak. So there's no reason to complain. (Well there is, actually. You could complain about the colour of the cassette or the hole in the ozone layer or the inadequate parking facilities in Uttoxeter. But we know how to deal with people like you, farty.)

So if you're in the market for a platform game starring someone who should have been dead thousands of years ago, rush along to your chemist and order a copy of *Big Nose* on the NHS. ☺



Big Nose waits for a grilled burger. The burger gives him energy, but the flames will roast his little bot if he gets too close.

All this jumping, running and blasting will take it out of you, so you've got to collect burgers and milk-shakes whenever you can. They give you energy, as do the beer mugs you occasionally bump into. But be careful because drinking the beer reverses your left and right keys, I suppose it's meant to represent getting drunk. You can still play on, but you'll need to think about what you're doing. Nice touch, Codies!

Unlike many platform games, you can't fall to your death cos you just land on whatever happens to be below you, and walk off. You can also steer while you're

FINAL VERDICT

LIFE EXPECTANCY	82°	ADDICTIVENESS	77°
GRAPHICS	78°	INSTANT APPEAL	77°

DIAGNOSIS
A good game. Much better than covering your bicycle with honey and inviting your friends to throw Rice Krispies at each other.

Quality Games at a Giveaway Price!

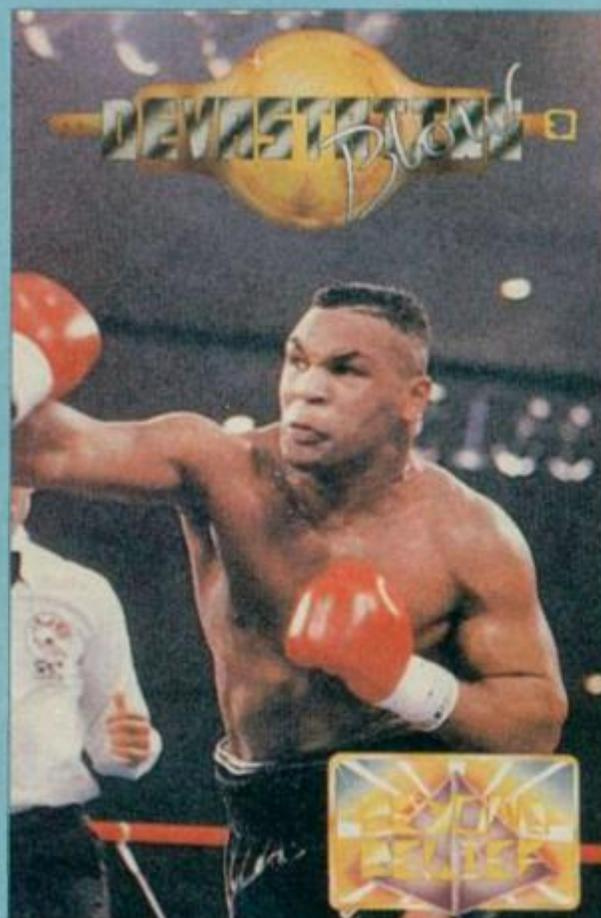
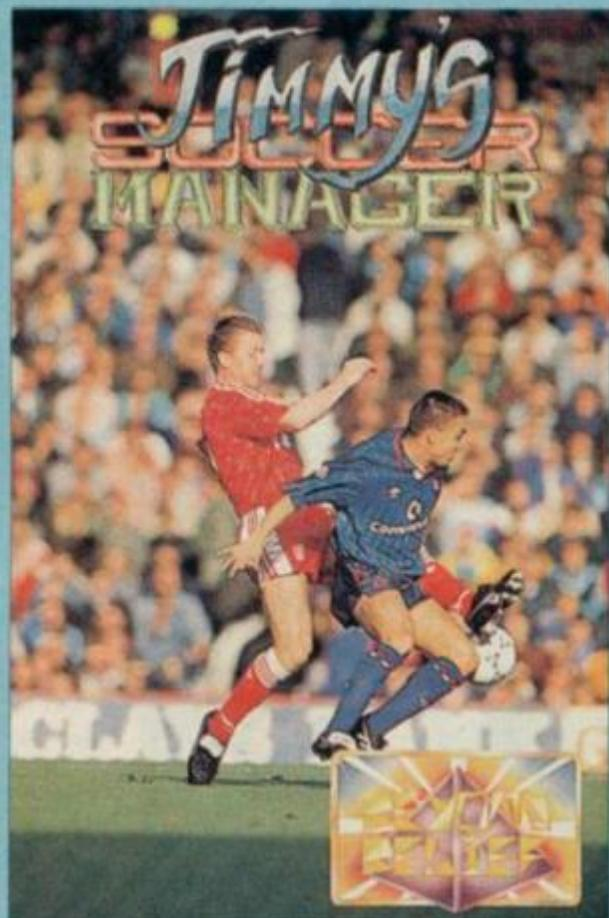

ONLY
£3.99

Beyond Belief, 19 Oaks Drive, Higham Ferrers, Northants, NN9 8EX. Tel 0933 57998



PROGRAM PITSTOP



DINNERS
READY
JONATHAN!



All JONATHAN DAVIES ever wanted was a Barbie-mobile. He didn't get one this year, so he's living in hope. Meanwhile, he'll make do with a few lists...

If you're a Spectrum owner who likes living life in the fast lane, who seeks the adrenalin-pumping thrills that only typing in listings can provide, who wants to be a hit at parties and attract lots of members of the opposite sex, you've turned to the right page.

And boy, have I got a line-up for you this month. (I had to check twice, but I have.) For starters there's - wait for it - a message scroller from **Andrew Hunt**. Then there's - gasp - a musical program from **Darren Bloggs**. And finally - swoon - a 'patch' for *Draw It*, your YS art utility.

ROCK AND SCROLL

by Andrew Hunt

I'm afraid your eyes don't deceive you: here's yet another message scroller. "But why?" you cry. "We've been faithfully typing in Pitstop scrollers for years, and we're up to our nostrils in the things. Our eyes have developed a permanent list to the left from watching messages scroll past. The last, the very last, thing we want right now is another scroller. Take it away. Cast it thither."

But have patience, please. Andrew Hunt's scroller is different. Okay, it's not that different, but it is remarkably short. It also scrolls messages which are a whole screen high, exceedingly smoothly and in a colour of your choosing. You can't say fairer than that.

Getting the thing up and running shouldn't take long. Just type in the BASIC section and save it with SAVE "scroller" LINE 9999. Then turf out a copy of the Hexloader from a previous YS and use it to enter the hex section. Save that as "code". Then reload and run.

Most of the BASIC listing is taken up by a demo, and an explanation of how it works. That saves me having to go through it all, as you should be able to work out how to replace Mark's message with your own without any trouble at all.



BASIC Section

```

9 LET START=0
10 LET X=65000
20 LET a$="KING SIZE SCROLLY..
  BY ANDREW HUNT FOR YOUR SINCLA
  IR..."
30 FOR N=1 TO LEN a$: POKE X-N
+1, CODE a$(N): NEXT N
40 POKE x+1, start-(INT (start/
256)*256)
45 POKE x+2, INT (start/256)
50 POKE x+11, LEN a$-(INT (LEN
a$/256)*256)
60 POKE x+12, INT (LEN a$/256)
70 POKE x+13, 5
80 RANDOMIZE USR (x+22)
90 GO SUB 200
100 POKE x+1, 0: POKE x+2, 0
110 FOR n=2 TO 7
120 POKE x+13, n
130 READ 1: POKE x+11, 1
140 RANDOMIZE USR (x+22+3)
150 NEXT n
160 LET a$="The End..."
165 FOR N=1 TO LEN a$: POKE x-n
+1, CODE a$(n): NEXT n
170 POKE x+11, LEN a$
175 POKE x+1, 0: POKE x+2, 0
180 RANDOMIZE USR (x+22+3)
190 PAUSE 100: GO TO 170
199 STOP
200 LET a$="Line 30 puts the me
ssage into memory...": LET a=LEN
a$
210 LET a$=a$+"Line 40-45 defin
es the start point...": LET b=(L
EN a$)-a
220 LET a$=a$+"Line 50-60 defin
es the message length...": LET c
=(LEN a$)-a-b
230 LET a$=a$+"Line 70 defines
the colour...": LET d=(LEN a$)-a
-b-c
235 LET a$=a$+"Line 80 runs the
code...": LET e=(LEN a$)-a-b-c-d
237 LET a$=a$+"Line 140 runs th
e code without resetting the scre
en...This must be done originall
y...": LET f=(LEN a$)-a-b-c-d-e
240 FOR n=1 TO LEN a$: POKE X-n
+1, CODE a$(n): NEXT n
250 RETURN
260 DATA a,b,c,d,e,f
9998 SAVE "scrollly" LINE 9999:
SAVE "code" CODE 65000,220
9999 LOAD **CODE 65000: RUN
    
```



Hex Section

```

65000 54 0A 00 00 00 00 00 00 =94
65008 18 18 00 0A 00 07 00 3C =125
65016 7E 7E 7E 7E 3C 00 CD 9C =925
65024 FE ED 4B F3 FD C5 ED 5B =1587
65032 E9 FD D5 CD 1E FE CD 7C =1517
65040 FE D1 13 ED 53 E9 FD C1 =1481
65048 0B 78 B1 20 EB C9 21 EB =1038
65056 FD ED 52 6E 7D D6 20 6F =1164
65064 26 00 29 29 29 ED 5B 36 =543
65072 5C 19 24 11 EB FD 01 0B =667
65080 00 ED 80 C9 AF 06 08 11 =820
65088 20 00 21 1F 58 DD 21 EB =673
65096 FD DD CB 00 7E 28 05 3A =906
65104 F5 FD 18 01 AF 77 19 77 =961
65112 19 77 19 DD 23 10 EA C9 =876
65120 06 08 21 EB FD CB 06 23 =779
65128 10 FB C9 21 01 58 11 00 =607
65136 58 3E 18 01 20 00 ED 80 =620
65144 3D 20 F8 C9 06 08 C5 CD =958
65152 3C FE CD 6B FE 76 CD 3C =1263
65160 FE CD 6B FE 76 CD 60 FE =1493
65168 01 00 01 0B 78 B1 20 FB =593
65176 C1 10 E3 C9 21 00 58 11 =775
65184 01 58 01 00 03 75 ED 80 =623
65192 21 00 40 CD B1 FE CD B1 =1115
65200 FE 11 F6 FD 0E 08 06 FF =1053
65208 1A 77 23 10 FC 77 23 13 =621
65216 0D 20 F3 C9 00 00 00 00 =489
STOP
    
```

TUNES

by Darren Bloggs

Pitstop is many things, but it tends to be a bit quiet. So I thought I'd liven it up a bit with a little music. I wouldn't normally print huge listings containing nothing but PLAY commands, as they're incredibly boring to type in (even by Pitstop's standards) and a nightmare to debug. But I think you'll find that this one's a cut above the rest, and just



■ Spectrum +2A for sale with joystick, over £400 worth of games and over £120 worth of mags. Games include *Total Recall* and *Nightshift*. Worth over £600, sell for £200. Also 48K for sale. Needs new membrane (£5) sell for £20. Phone Mark on Leicester 386454.

■ ZX Specy +48K, with around 30 games including good ones like *Led Storm*, *Midnight Resistance* and *Quattro Sports*. All leads, Cheetah joystick, user manual and a programming book. Sell for £55 without cassette player, £65 with one. Phone 091 268 2448 and ask for Richard.

■ Spectrum 128K +2A with lightgun. Hardly used, excellent condition. 15 magazines with cover tapes and over 150 excellent games (including *Robocop*, *Sim City*, *SWIV*, *Chase HQ* and *Batman*). Worth well over £500, will sell for £225 ono. Phone 0268 750165 after 6pm.

■ Spectrum 128K +2 dual Kempston interface. Joystick, many new full price games including *Carrier Command*, *Myth*, *Man United Europe*, *Sim City* and *Coin Op Hits 2*. Plus! £100 worth of Spectrum mags. £900 worth in all. Sell for £200 ono. Phone Sam after 5pm on 0494 728458.

■ Microdrive cartridges - £1.25 each. Interface 1 and Microdrive - £32. AMX mouse and mat - £27. Call 0779 796999.

■ For sale: Spectrum +3, TV, cassette recorder, leads, Multiface 3, disks, games on disk, £1000's worth of cassette games, 2 joysticks, lightgun, magazines, books and manuals. All for £290. Phone 0909 563229.

■ Spectrum +2A Actionpack for sale. Also Multiface 3, lightpen, six expensive books and six expensive games. Worth £300, will accept £150. For software worth £160 will accept £50. Ring 0242 581232.

■ Atari ST boxed with joystick magazines and over 20 games: £180. Phone 021 730 2261.

■ Spectrum +2 James Bond pack with lightgun, joystick, nearly 200 games and drum machine. Also 30 mags. All this for £190 ono. Will throw in a 48K Spectrum with leads. Call James on 0621 741550.

■ For sale - lightpen for Spectrum +2 and games (*Aliens*, *Chuckie Egg 2*, *Trap Door*, *Rebel*, *Battle Field* and *Rambo*). Good condition. £20 ono. Phone Plains Farm 5220663.

■ Spectrum +3, boxed, £100's worth of new disk games, word processor, many tape games, good tape recorder, all manuals and leads and two joysticks. £150 ono. Phone Stuart on 0462 711127.

■ Spectrum 48 - £35 + £6 postage.
Spectrum 128 +2 - £60 + £6 post.
Spectrum +3 - £70 + £6 postage. Serial printer 8056 - £20 + £6 postage.

Microdrive cartridges - £1.25 each plus postage. Mouse and Artist 2 - £22 + £2 post. Power supplies - £5 + £5 postage. Ring 0257 278464.

■ Spectrum 48K for sale with new power pack, leads, dual interface and Crusier joystick with 10 games for £90. I also have over 110 mags with 250 covermount games. Will sell everything for £190 ono, or £1.50 for each mag + tape. Call 077 84194 after 6pm.

■ Spectrum +2 with two joysticks and interface. Over 100 games (including *Strider 2*, *Dizzy Collection* and *Kick Off 2*). Speccy 48K and ZX printer. All for £110 ono. Phone Stuart on 0772 39720.

■ Spectrum 128K +2 (boxed), over 300 games, including 42 full price ones. Joystick, Multiface 128, over 60 mags and 40 cover tapes. Worth over £1000, will sell for £375 ono. Phone Kevin on 0472 341518.

■ Spectrum +2A, keyboard cover, 180 games, manual joysticks and lightgun. Very good condition. Sell for £130. Call Simon on 021 7056699.

■ 48K Speccy, over 100 games, tape recorder, two joysticks, interface and magazines for £65. Phone 03552 20810 after 4pm, Mon - Fri.

■ For sale! Spectrum 128K +2, manual, aerial lead, 30 games, power unit and two joysticks. £125 the lot, ono. Ring Christopher on 021 747 9705 after 6 pm.

■ Spectrum 124 still boxed. Includes lightgun, over 100 games, magazines and all leads. £300. Tel Garry on Newcastle Upon Tyne 2641615.

■ Speccy 48K plus leads and a tape recorder. I will also chuck in the *Konami Collection*. Going for £35 ono. Ring 0978 750666 and ask for Darren.

■ Spectrum +3 with games, art packages, word processor, databases. A mere £130 Ring 051 678 7501 and ask for Adam. 0625 871200.



■ I will swap my Manchester United for your *Gazza's Super Soccer*. Also wanted - *Turtles*. I will pay £4, or £5 if sent by post. Call Phillip on 0462 434999.

■ I will swap TMHT, *Batman*, *Treasure Island Dizzy*, *Fantasy World Dizzy*, *Prison Riot*, *4 x 4 Off Road Racer* and a joystick - all for your *Golden Axe*. I really need it, I'll also pay. Call Jude on 0494 711917.

■ Get ten super games like *Target Renegade*, *Platoon* etc. Will sell for £10. Phone Garry in the evening or at weekends on Birmingham 783 4853.

■ I will swap my *Moonwalker*, *Baseball*, *Daley Thompson's Decathlon*, *Spooky Castle*, *Ping Pong* and *Space Harrier* for *Battle Command*, *Untouchables*, *Pit-Fighter*, *Dick Tracy* and *Vigilante*. Phone Lee on 0602 870161.

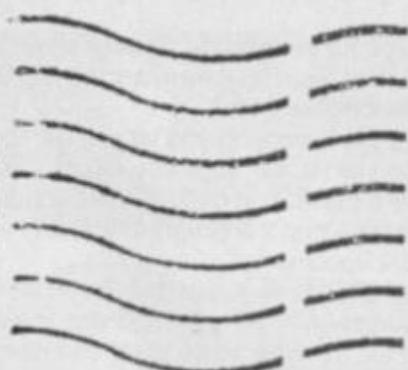

If all your pressies were crap, don't despair. Just stick them in Inny Outy and pick up something better. It's Christmas day every day around here!

■ Lucky dip! Five games for £3.50. Speccy 48K, alphacom, cassette, manual and games for £80. Games Designer for £3.50 game compilation - £3 and Atari SXE plus Atari mags for £80. Ring Mackowski on 081 6983739.

■ Loads of software to swap and sell. Eg - *Shadow Warriors* - £4.50, *Dragon Ninja* - £2, *Platoon* - £2.50. All originals. Phone David on Reading 832196.

■ Urgently wanted - *Lords Of Midnight* and/or *Doomdark's Revenge*. Any offer considered. Call Ben on 0792 459587.

■ I will swap my *Barbarian*, *British Super League*, *Thing and Danger Mouse* for your *Altered Beast*, *Seymour Goes To Hollywood* and *Cauldron*. Ring Paul on 0204 44125.

■ I will swap my *Ghouls And Ghosts*, *Coin-Op Hits*, *Ninja Warriors*, *Batman The Movie*, over 50 covertapes, *Paperboy*, *Daley Thompson's Olympic Challenge*, *Run The Gauntlet*, *California Games*, *World Cup Soccer 90* and *Renegade* for your *World Class Rugby*. Phone Christopher on 081 3903597.

■ Wanted - *Aliens*, the US version. I will swap *Nightshift*, *Marauder*, *Fighter Bomber*, *Lords Of Chaos* and *Impossible*. Ring Jason on 0902 491610.

■ I will swap *Lords Of Midnight* (48K) and *Frankie Goes To Hollywood* (48K) for one of the following *Hero Quest*, *Coin-Op Hits* or *Gremlins 2*. Phone Craig on 0978 263257.

■ I will swap my *Knightmare*, *Chase HQ*, *Nigel Mansell's Grand Prix*, *Panic Dizzy* and *Kwik Snax* for your *Renegade*, *British Super League*, *Soccer Double*, *Boulder Dash* (1, 2, 3 or 4) and *Professional Soccer*. Call Anthony on 0222 793758 after 7pm.

■ I will swap my *Prince Clumsy*, *Vampire*, *Frost Byte* and *Cavemania* for your *Wonderboy*, *Bubble Bobble* and *Cauldron 2*. Ring Paul on 0204 44125.

■ For sale! Loads of games such as *Hero Quest* £8, *Loopz Collection* £12, *Dizzy Collection* £8, *Back To The Future 2* and 3 £10. For more details contact Andrew in the evening on 0670 514918.

■ I'll swap *Rastan* and *720°* for *R-Type* and *Chase HQ2*. Phone Steven on 0434 606479.

■ Has anyone got *Shadow Dancer* or *Golden Axe*? If you have, do you want to swap it for *Final Fight*? Originals only. Phone 0902 765 274 and ask for Mark.

■ I'll swap my *Fighting Soccer* or *Thunderbirds* for *Chase HQ2*, *Super Monaco Grand Prix*, *Lotus Esprit Turbo Challenge* or *Dizzy Collection*. One for one or two for two. Must be boxed and contain instructions. Ring Daniel on 0204 493438.

■ I will swap my *Hard Drivin'* for your *Cyberball*. Either that, or I'll sell it for £4. Call 091 548 1786 after 4pm and ask for Paul.

■ Speccy 128K games for sale. Approx 350 games for £50. A complete and utter bargain! Offers considered. Ring Stephen on Cirencester 655973.

■ I will swap my *Final Fight* (128K cass) for your *World Class Rugby* (cass) or *Turtles 2: The Coin-Op*. Boxed originals only. Interested? Then phone Stewart on 0203 683574 from 7pm to 8pm. Don't phone at weekends.

■ Desperately seeking *Maziacs* for the 16K/48K. Cassette only please. Phone Ian after 6.30 pm on 0954 782621.



■ Wanted - *Lone Wolf +3 Disk*. I'll swap for *Xenon* and *Time Machine* for +2. Also swap my *Forgotten Worlds* for your *New Zealand Story*. Phone Kevin on 0946 830692.

■ Wanted - a disk drive (preferably with some disks) for a Spectrum 128K +2A. All offers considered. Please phone Mark on 0902 735909 after 4pm weekdays.

■ I want any *Dizzy* game please. I'll swap you for my *Gnasher*, *Monty Is Innocent*, *Jetset Willy*, *Finders Keepers* and *Spellbound* (48K games only). Call 0454 281673 4-5.30pm and ask for David.

■ Wanted - *Wheels Of Fire*, *Power Up*, 100% *Dynamite*, *Hollywood Collection*, *Winning Team* and *System 3 Collection +3* disk. Will swap mixture of games including *Lords Of Chaos*, *TMHT*, *Dizzy 1, 2, 3*, *Spy Vs Spy 1, 2*, any of the *Quattro* packs, etc. Phone Richard on 0642 760839 after 4pm. No copies please.

■ Wanted - Printer and interface for Spectrum 128K computer. Phone David or Mrs Horton on 0203 335438.

■ Desperately wanted! *Sherlock* for 48K Speccy. Phone Pete on 048641 3151 (day) or 048641 3314 (evening).

■ Wanted - *WWF* and the *Running Man* for *Dan Dare 3* and *Vigilante*. Phone James on 0889 26282. One for one please!

■ Wanted - Any classic Speccy game, games in bulk if possible. *Operation Wolf* desperately wanted. Will give cash. Must be in Wakefield area. Phone Ryan on 0924 252825.

■ 48K Word Processing for Sinclair ZX Spectrum also user guide. Phone 0443 690726.

BOOK YOUR FREE AD HERE

If you'd like to advertise in Input/Output, please write in BLOCK CAPITALS below and send the coupon on the back of a postcard to Input/Output, YS, 30 Monmouth Street, Bath BA1 2BW. If you are under 18

please ask your parent or guardian to sign the coupon for you, and don't forget to add your phone number. We can't accept any software sales, and this service is only available to private advertisers.

Please enter my advert under the following classification:

Hardware Software Wanted Messages & Events Fanzines

Name Address.....

.....

..... Postcode.....

Tel No Signature of parent/guardian if under 18

.....

.....

.....

MAGAZINE HEALTH WARNING

Think before you snip - most people use a photocopy instead

YS 74

YOUR SINCLAIR Feb 1992 48

Sorry, but YS can accept no responsibility for the ads placed in Input/Output

■ I want *Final Fight*, *Golden Axe* and *Viz*. I will swap you my *Super Monaco GP*, *STUN Runner*, or *Dan Dare 3*. Tel David on 0222 862330.

■ Wanted - *Rick Dangerous 2* - I will only take an original. Crimes are: not being stocked in a shop, being full price. Reward *Yie Ar Kung Fu 2*, *Road Runner*, *Fruit Machine Sim One*. Phone Robin on 0686 650497.

■ Wanted - Multiface suitable for 48K. Will swap for three full price games or six budget games. Will buy for a reasonable price. Please phone Elliott on 081 550 8195.

■ Wanted - your *Robocop* for my *Renegade* and *Batman*. I also have *Double Dragon 1* and will swap for your *Afterburner 2*. Phone Inverness 242378.

■ Over 40 games for £12 ono. and also two joysticks for *Toki* and *Lone Wolf*, and I will write you out cheats, tips etc for £1 if you want!! Phone Lee on Hastings 712436.

■ Wanted! Books, games, user manual, for Acom Electrom. Phone Arthur on 051 260 4183.

■ Wanted! *Runaway Train* (Sinclair) and *Jumping Jack* (Imagine). Phone Colin on 0737 241265.

■ Wanted - *Lightgun*. Will swap for *Out Run* and *Hard Drivin'* or *Spectrum*. Also wanted good working printer and leads, would swap approx 8 budget games. Tel Jonathan on 0869 47223.

■ Wanted - hard "Y" connector for expansion port for Spectrum+. Good price paid. Phone 0738 22031 after 6pm.

■ Wanted - *Heroes Of The Lance*. I will swap for *Hero Quest* and *Robocop 2*. Originals only. Please include manual. Call Roger on Norwich 788382.

■ Wanted - *Hijack*, *Everyone's A Wally* and *Pyjamarama*. Will buy for up to 35 each. Ask for Gary on 0525 375586 after 4pm.

■ Wanted - *Flying Shark*, *Plotting*, 1942 and *Xenon*, *Italy 1990*, *Vigilante*, *Ghostbusters 2*, *Microprose Soccer*, *Fist 2*. Will buy for £3 each. Phone Ben on 0258 72517 4pm - 8pm (not Mon or Tues).

■ I have a Spectrum +3 and would like to swap my *NARC*, *Skate Or Die* and *Ghouls And Ghosts* for disks of *Hard Drivin'*, *Chase HQ2*, or *Lotus Esprit Turbo Challenge*. Originals only. Phone Jeff on 0903 242488.

■ Wanted desperately! *MERCs*. Will swap *Operation Thunderbolt*, *Back To The Future 3* and *Red Heat*. All my games for *MERCs*. For this brill offer phone Paul on 021 328 5850.

■ Wanted! *Jet Set Willy 2*, *Kokotoni Will*, *Sir Lancelot*, *Penetrator*, *Frank 'n' Stein*, *Brian Bloodaxe*, *Dynamite Dan 1* or *2*. Originals only please. Call Gary on 051 4885595.

■ Wanted! A book called *Make The Most Of Your ZX Microdrive* by Ian Sinclair and *Microdrive And Interface 1* manual. Ring Eddie on 0482 224735 and state price.



■ I want your machine code or BASIC programmes for my public domain catalogue. I will sell your programmes for a quid each (the price of the tape and postage) and get your program into circulation. For more info call Danny on 0704 642556.

■ Chic! The best user group for Spectrum owners. Unbeatable service. Also want PD, fanzines and shareware to review. For more details call Steve on 0753 884473.



■ New! *Dizzy Magazine* with letters, reviews and big competitions. 50p with sae or 75p without. Interested? Phone Andrew on 08883 356 after 6pm.

■ ACFC Games present *The British Super League*. The best value for money PBM on the market. For details phone Cletius on 061 792 7540.

■ Out now! Special free issue of *Soft Sell*, the Spectrum and SAM Coupé software trading fanzine. Phone Dan on 0272 604980.

■ Yo! Any ace programmers want a fanzine just for you? Then *Program Your Spectrum* is the mag for you. This ace thing contains programmes and pictures and cool compos. Phone Philip on Brierly Hill 892231.

■ *Manager Of The Year*. Realistic and fun soccer PBM with trophies for winners. Phone Andrew on 0629 55994.

Your guarantee of value

This magazine comes from Future Publishing, a company founded just six years ago, but which now sells more computer magazines than any other publisher in Britain. We offer:

Better advice. Our titles are packed with tips, suggestions and explanatory features, written by the best in the business.

Stronger reviews. We have a cast-iron policy of editorial independence, and our reviews give clear buying recommendations.

Clearer design. You need solid information fast. So our designers highlight key elements by using charts, diagrams, summary boxes, annotated photographs, etc.

Greater relevance. At Future, editors operate under two golden rules:
• Understand your readers' needs.
• Satisfy them.

More reader interaction. We draw strongly on readers' contributions, resulting in the liveliest letters pages and the best reader tips. Buying one of our magazines is like joining a nationwide user group.

Better value for money. More pages, better quality: magazines you can trust.



Home of Britain's finest computer magazines.

Your Sinclair • Commodore Format
Amiga Power • Amstrad Action • Sega
Power • PC Format • Amiga Shopper •
PC Answers • PCW Plus • PC Plus
Amiga Format • ST Format

BACK ISSUES

£2.40 each or...

Special Offer

SAVE £4.40!

6 issues for only £10

(Prices include covertape, postage & packaging)

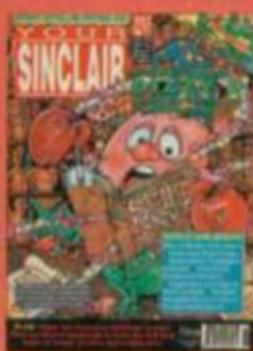
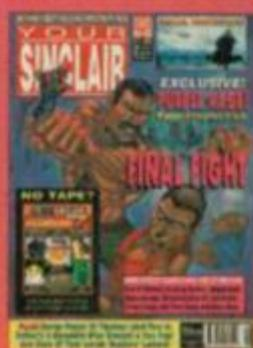

62 FEB ONo Y562
Marsport/Wizard's Lair/Moonlight Madness on the tape. PLUS! *Pang* and *F-16 Combat Pilot* Megagamed.

63 MAR ONo Y563
3 games (*Biggles*, *Earth Shaker*, *Dun Darach*) and 2 demos (*BTF3* & *Switchblade*).

65 MAY ONo Y565
How To Be A Complete Ahem, *Tir Na Nog* and *Ninja Hamster* on the tape. Plus *Helter Skelter*, *Lone Wolf* and *SWIV* Megagamed.

66 JUNE ONo Y566
On the tape - *Rampage*, *Ice Temple*, *Syntax*, *Dominion*, *Mystical* and more! PLUS! *How To Write A Fanzine!*



67 JULY ONo Y567
Get down on the covertape to *Brainsport*, *Ad Astra*, *Hijack*, *Double Agent*, *Cromwell* at War and much, much more! Plus! *Taki & Alien Storm* Megareviewed!

68 AUG ONo Y568
On the tape - *Tempest*, *Southern Belle*, *Super Cup Football* and more! PLUS! Megareviews of *Final Fight* and *Darkman* AND! *3D Construction Kit* Megagamed!

69 SEPT ONo Y569
Terminator 2 and *Indy 4* Megareviewed! *Olympus* and *Heavy On The Magick* on the tape. Plus! Demos of *Robozone*, *Football Manager 3* and *3D Construction Kit*



70 OCT ONo Y570
FREE! Hooked On Classics tips booklet! *Nigel Mansell's Grand Prix* and *Klimax* on 'tape. And! Demos of *Chevy Chase*, *World Cup Rugby* and *Prince Of Persia*. Inside - *Mega Twins* and *The Simpsons* Megareviewed!

72 DEC ONo Y572
Reviews of *The Simpsons* and *Turtles: The Coin-Op*. On the tape: *Lemmings*, *Seymour: Take One*, *Aliens* and more.

73 JAN ONo Y573
FREE! Groovesome diary! *GAC* and *Cisco Heat* on 'tape. Inside - *Lemmings*, *WWF*, *Rodland* and *Dizzy* Megagamed. Plus! A massive SAM Coupé feature. It's ace.

Please use the form opposite to order the special offer or any of the back issues.

We still have limited supplies of issues 2 - 61.

This month's front cover crossword clues:

Down:
1: If you start seeing this, then get seriously worried and see your optician immediately. (6)
2: A short All Points Bulletin. (3)
3: Don't stick it in the air, or it might get put out of joint. (4)
4: Horns used for signalling, or as drinking vessels. (6)
7: Dizzy's bit of skirt. (5)
8: ... upon a time. (4)
12: The official US intelligence

analysis organization responsible for external security. (8)
14: To ... or not to ... (2)

Across:

1: Mythical fire-breathing creature. (6)
4: Mikey J's chimp. (7)
5: A pub without a p. (2)
6: The man in charge. (2)
8: US Gold's latest tale of fear and flight. (4)
10: Mr Fairclough to you, matey. (3)

11: 'I saw' in Latin. (4)
13: Citizens' Band. (4)
15: Used as third person singular. (2)
16: Lots of cars racing round a track, it's also reviewed in this ish. (8)

Send your answers, on a postcard, to: YS February Crossword, YS, 30 Monmouth Street, Bath, Avon, BA1 2BW. The winner gets three free games and some YS goodies!

Editor Andy 'Yes way Bill' Hutchinson Art Editor Andy '999' Ousted Games Editor James 'Righteous' Leach Staff Writer Linda 'Ooooh, you two!' Barker Art Assistant Maryanne 'Belle of the ball' Booth Contributors Marcus Berkman, Stuart 'Mr Popular' Campbell, Jonathan Davies, Jon North, Rich Pelley, Jon Pillar, Adam 'Hardly Waring' Advertising Manager Cheryl Beesley Publisher Jane 'You're fired' Richardson Promotions Manager Michele 'Cos you're the editor' Harris Publishing Assistant Tamara 'High Security' Ward Circulation Director Sue Hartley Circulation Assistant Kate 'Even Fatter Hodges Group Publisher Greg 'Onwards and ermm...' Ingham Managing Director Chris Anderson Production Coordinator Lisa 'Poppy Read Production Technicians Simon Windsor, Chris Stocker, Jerome Clough Subscriptions/Mail Order The Old Barn, Somerton, Somerset (tel 0458 74011) Printers Riverside Press, Gillingham, Kent Distributors MMC (tel 0483 211222). Your Sinclair is elevated to a god-like status by Future Publishing Ltd, Beauford Court, 30 Monmouth Street, Bath, Avon BA1 2BW (tel 0225 442244). © Future Publishing 1992. No part of this magazine may be reproduced without written permission except for the bit where Jane says "My scarlet strides are large and whiffy, so taste the goblet that's been washed with Jiffy!"

SPEC SCHOOL

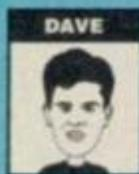

DAVE Remember how you conned your mum and dad into getting you a Speccy? "I won't just play games on it, honest, mum! Computers are an essential part of the modern world, and you wouldn't want me growing up deprived and technologically backwards, would you?"

And ever since it's been one long round of blasting, leaping, joystick-wagging and generally mind-rotting your-mother-wouldn't-like-it fun!

So, just to keep 'em from whingeing about you wasting your life, why not check out a couple of educational programs (said through gritted teeth). No, honest, they're not as bad as they sound.

The bunch reviewed here are all for under-eights, so for most of you they'll only be any good if you've got a kid brother or sister. Still, they'll keep your mum happy and keep little Johnny from using your Kylie records as frisbees. That's if you trust him with your Speccy, of course!

Picture Book

Triple R Education/£12.95 cass

A is for apple and B is for books are blimmin' borin'. Turning over pages is such a drag, and the pictures are so, well, static. Could *Picture Book*, a four-program package that aims to file traditional paper picture books next to Bros, as a thing of the past, be the answer?

The main program is *Alphabet Book*, and is basically an animated picture book. There're 26 pics, which is handy as each of them is of an object starting with a different letter. You type in a letter on the keyboard and a piccie of an object that starts with that letter pops up on screen, along with its name. The advantage it has over traditional picture books is that the piccies are animated - the sails on the windmill go around, the apple has two great chunks taken out of it, that sort of thing.

According to the packaging the graphics were designed by a bloke with a degree. What did he get his degree in, crapness? It certainly wasn't in designing Speccy graphics. Look up blocky in a dictionary and the definition will probably say, "Check out *Picture Book* on the Spectrum." Colourful, yes. Distinguishable, no. The eggs look like disembodied eyeballs.

The other three games all make use of the same 26 pictures, worse luck. *Snap* is based on the traditional card game. Up to three players can take part. All it involves is the computer displaying two pictures and if they're the same you have to press your allotted key on the keyboard before anyone else. A bit dull if you play on your own, with two or three people it can get quite frantic and quite good fun.

There are three levels. In level one you just have to match pictures. This is handy as you don't have to know what the object is supposed to be - if two orange blobs come up on-screen then you know they're supposed to be a match. In levels two and three you have to match a word with the object.

In *Count 'Em* you have to, um, count 'em... A number of objects appear on screen and you have to tot 'em up and type in the number on your keyboard. Simple enough, but it makes good use of colour and there's a brill farty sound when you get the answer wrong.

In *Spell It* you have to, um, spell the name of the object pops up on screen (lots of thought went into the titles here). A nifty screen layout, bold colours and big bright text spruce things up no end.

Picture also comes with what the packaging proudly boasts to be 'revolutionary keyboard overlays'. Are they telepathic? Do they tell you when Neighbours is on the telly? Nope, they are just little polythene things that have the letters printed in lower case and in alphabetical order. Wow.

Picture Book is dead easy to use - a four year old could hack it which is lucky since that's who it's aimed

USE EXPERTISE	●●●●●●●●	8	●●	FINAL VERDICT
ADAPTIVENESS	●●●●●●●●	7	●●	FINAL VERDICT
IMAGINATIVE	●●●●●●●●	7	●●	FINAL VERDICT
INVENTIVE APPAL	●●●●●●●●	7	●●	FINAL VERDICT
FINAL VERDICT	●●●●●●●●	7	●●	FINAL VERDICT

GRADE Should keep the rippers out of trouble for a while.

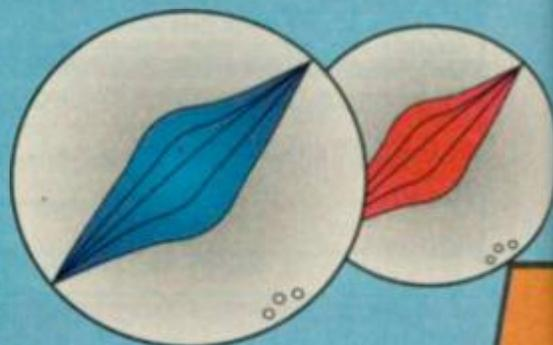

Count And Add Lander £???.??



Maths is crap and *Count and Add* tries hard, but fails, to liven things up.

Maths! Universally hated by all schoolkids (except the weird nerdy ones who don't count anyway because they're not normal). But don't worry, 'cos *Count and Add* is certainly a better introduction to numbers than being taught by a teacher who looks like Freddy Krueger and is twice as deadly with a piece of chalk.

There are five games here, though they're all pretty much variations on a theme. Even the graphical layout is much the same in all of them. In *Sets 1*, a number of things appear on screen and you have to count them. In *Sets 2* you are told how many things there are supposed to be and you have to tap the space bar to reveal them.

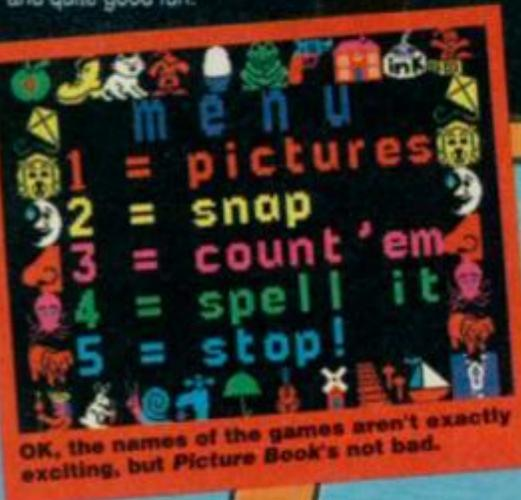

OK, the names of the games aren't exactly exciting, but *Picture Book's* not bad.

Fun School 4 - Under 5s
Europress Software £12.99 cass
£16.99 disk

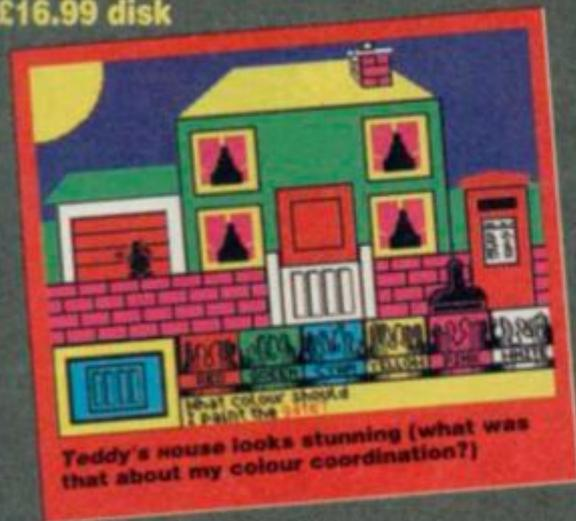

The acclaimed *Fun School* series teaches kids all about such loathsome things as spelling and maths so painlessly that they hardly notice that it's doing them good. The latest Under 5s package has six games all featuring various members of the Teddy family, who all just happen to be bears.

Apparantly, *Addition* is set in a nursery school, but it looks suspiciously like a normal school to me. There's a blackboard, a teacher and, worse of all, simple addition sums to be done. Still, if you get them right, you're allowed to go home early, hurrah!

Fun Train is all about matching pictures and words. One of the Teddies drives a train past a poster showing a picture or word. The train carries another picture or

word in its tender. If they match, press the space bar and feel very proud of yourself. Nice concept, and nice graphics, even if the same pictures do keep cropping up over and over again.

Teddy's House is a fun painting program. In the lower levels you just paint the Teddies' house in whatever colour scheme you fancy. On higher levels the computer asks you to paint specific parts of the house in certain colours. It all gets loads more difficult when the names of the colours are taken away - a bit of a toughie.

Teddy D's Karaoke is a work of sheer genius. MC Teddy struts his funky stuff to the hits of the nursery; The Grand Old Duke Of York, Jack and Jill, they're all here. Your Speccy plays the tune and displays the words so that you can sing while Teddy D grooves. Great stuff. On Level Two you can hit the space bar really fast and watch Teddy D rock.

Then there's *Teddy's Book*, in which you have to work out which bed-time storybook daddy Teddy is reading to his cubs. Finally, *Teddy Paint* is a not-much-fun paint program that lets the collection down a bit.

Otherwise it's a brilliant disk with appealing characters, effective use of colour and spiffy sound fx. The only problem'll be prising your kid brother or sister away from the keyboard when you want to get back to *Dizzy*. ☺



TEN THINGS THEY DON'T TEACH YOU AT SCHOOL

- How to be a millionaire pop star.
- Advanced cheese and onion crisp appreciation.
- What to tell your mum when she catches behind the bikeshed with Susie Barnes.
- How to eat three shredded wheat.
- How to pat your head and rub your stomach at the same time.
- Where to buy peanut butter, candyfloss and banana milkshake-flavoured toast toppers.
- Who won the FA cup in 1962.
- How to stop all the little scaley bits from the kettle getting into your tea when you don't have a tea-strainer.
- How Extreme manage to make such crap records.
- Why Spiderman's face goes absolutely smooth when he puts his mask on.

Fun School 4
5 to 7 year olds
Europress Software £12.99 cass
£16.99 disk

Animals is virtually the same as *Sets 1* but they try to trick you into thinking otherwise by dotting the animals all around the screen instead of lining them up neatly and having a bone to climb a ladder each time you get an answer correct (I'm not sure if there's some deep message to this imagery).

Train is where the real work starts. Yep, it's time to add things up (shudder!) If you're successful, a train chuffs its way along the top of the screen.

Spider sees you having to rescue a Butterfly from a hungry arachnid using your mathematical prowess. If you get a fairly simple sum right the butterfly moves further away from the ever-approaching spider.

None of the games are exactly engrossing, and are not helped by some really dull graphics - they're little more than black and white line drawings on wishy-washy coloured backgrounds. The reaction time is sluggish to the point of Jeremy Beadle-type irritation. Still, the sound is excellent, and the little celebratory jingle you get if you get all the answers in a section right is almost worth playing the games for. ☺

Fun School for the more mature little Spec-chum. The linking character here is Freddy the Frog - I mean, at five you're just too old for Teddies, aren't you? (Unless you're James, of course.)

Best of the six games here is *Typing* which features a dopey-looking crocodile who's hot on Freddy's tail. You can save Freddy by typing in certain letters, words or sentences. Type them correctly and Freddy hops hurriedly out of the range of the crocodile's teeth.

Finally he reaches an island where someone has left a hefty-looking mallet. And guess what you use that for? All the crocodile-bashing happens off screen, but the great graphics and wicked sense of humour make this an excellent little game.

In *Opposites* Freddy and his wife want to go swimming, but the farmer who owns the pool will only let them if they answers questions about opposites. The pool is covered with lily pads, some of which have words on. The computer gives you another word, small for example, and you have to guide Freddy to the lily pad that says tall. When you've got a certain amount right Mrs Frog leaps into the pool. The nifty graphics liven things up and the whole thing's pretty spiffy.

Shopkeeper is all about working out how much things cost, whether you've got the right money and what the change should be. Freddy starts out going down the shops and ends up as the manager of a supermarket. Verdict? Okay, if a little static.

In *Log Cabin* Freddy has to build a log cabin before he can have his dinner.

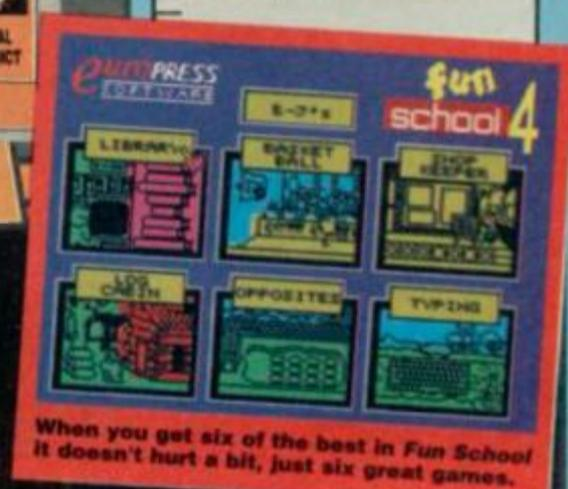

There's a few multiple choice maths problems that you have to answer correctly to get a log. Freddy picks up the log and, like a champion caber tosser, hurls it into position.

Basketball has you filling in the gaps in a series of number or letters. You know the sort of thing - A, B, C, ?, E. Get it right and Freddy throws a ball through a basket ball hoop. The animation is spiffy, but it's all a bit slow.

Library is just a case of putting books in alphabetical order. Nice graphical presentation but the actual game is about as exciting as counting how many time the letter z crops up in the end credits of *Neighbours*.

Again, the manual is presented in the form of a story and the idea just about comes off. Despite some irritating niggles, this disk still beats *Play Bus* anyway. ☺

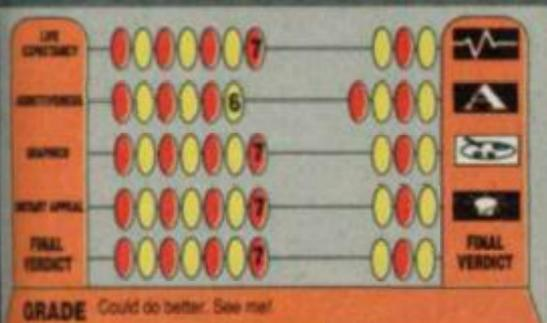

+1D

System

INTERFACE & DRIVE

THE ULTIMATE SPECTRUM ADD-ON!....

WITH THIS AMAZING DISK DRIVE AND INTERFACE PACKAGE YOU CAN BRING YOUR SPECTRUM INTO THE WORLD OF SUPERFAST DISK STORAGE AND RETRIEVAL

- The PLUS 'D' System consists of a top quality double-sided Disk Drive (complete with power supply) and the powerful PLUS 'D' Interface. Plus connecting cable.
- Full 80 track Drive giving almost 800K of fast disk storage using the industry standard 3.5" disks - (available anywhere for under £1.00 each) with enough room for up to 16 full size programs per disk!!
- Offering more than twice the storage capacity of a standard IBM Disk Drive and even more than an ATARI ST, the PLUS 'D' System takes you into the realms of mass storage.
- Load programs at Superfast Speed!! - a whole 48K program in seconds. No more waiting for tapes to load.
- The PLUS 'D' actually gives your Spectrum an alternative operating system with dozens of advanced commands.
- Extremely simple to use but very advanced in it's speed and operation.

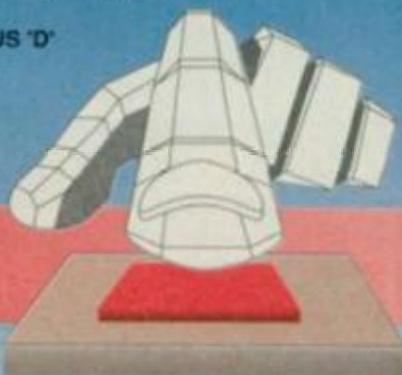

BUT THATS NOT ALL!! THE PLUS "D" HAS A UNIQUE "SNAPSHOT" FEATURE!

- Yes, at the press of the "Snapshot" button you can freeze the program in memory and save it to disk.
- Transferring tape programs to disk couldn't be simpler - up to 16 per disk!
- Works with 48K and 128K programs.
- Special 'Screen Dump' feature allows you to print out any screen to an Epson compatible printer. (Printer lead available £9.99 if required)

AVAILABLE FOR 48K/128K/+2/+2A/+3 COMPUTERS (PLEASE STATE WHICH WHEN ORDERING)
NOTE THAT THE +2A COMPUTER HAS A BLACK CASE UNLIKE THE +2 WHICH HAS A GREY CASE. IT IS IMPORTANT TO STATE EXACTLY WHICH MODEL OF SPECTRUM YOU HAVE WHEN ORDERING.

If you have your own suitable Disk Drive (Plus 'D' will work with 40 or 80 track 5.25" or 3.5" drives) then we can supply the Plus 'D' Interface separately for
ONLY £59.99

COMPLETE PLUS D INTERFACE AND 800K DISK DRIVE POST FREE!!

ONLY £129.99

WARNING 1988 COPYRIGHT ACT WARNING

Datel Electronics Ltd., neither condones or authorises the use of its products for the reproduction of copyright material. The backup facilities of this product are designed to reproduce only software such as Public Domain material, the users own programs or software where permission to make backups has been clearly given. It is illegal to make copies, even for your own use, of copyright material, without the clear permission of the copyright owner, or the licensee thereof.

HOW TO GET YOUR ORDER FAST!

TELEPHONE [24Hrs] **0782 744707** CREDIT CARD ORDERS

ORDERS NORMALLY DISPATCHED WITHIN 48 Hrs. ALL CHEQUES/POSTAL ORDERS MADE PAYABLE TO...



DATEL ELECTRONICS LTD.



GOVAN ROAD, FENTON INDUSTRIAL ESTATE, FENTON, STOKE-ON-TRENT, ST4 2RS, ENGLAND.
FAX 0782 744292 TECHNICAL/CUSTOMER SERVICE 0782 744324

DATEL
Electronics

DATEL Electronics

**NOW A TOTAL MOUSE/
GRAPHICS PACKAGE
FOR YOUR
SPECTRUM
AT A TRULY
UNBEATABLE
PRICE!!**

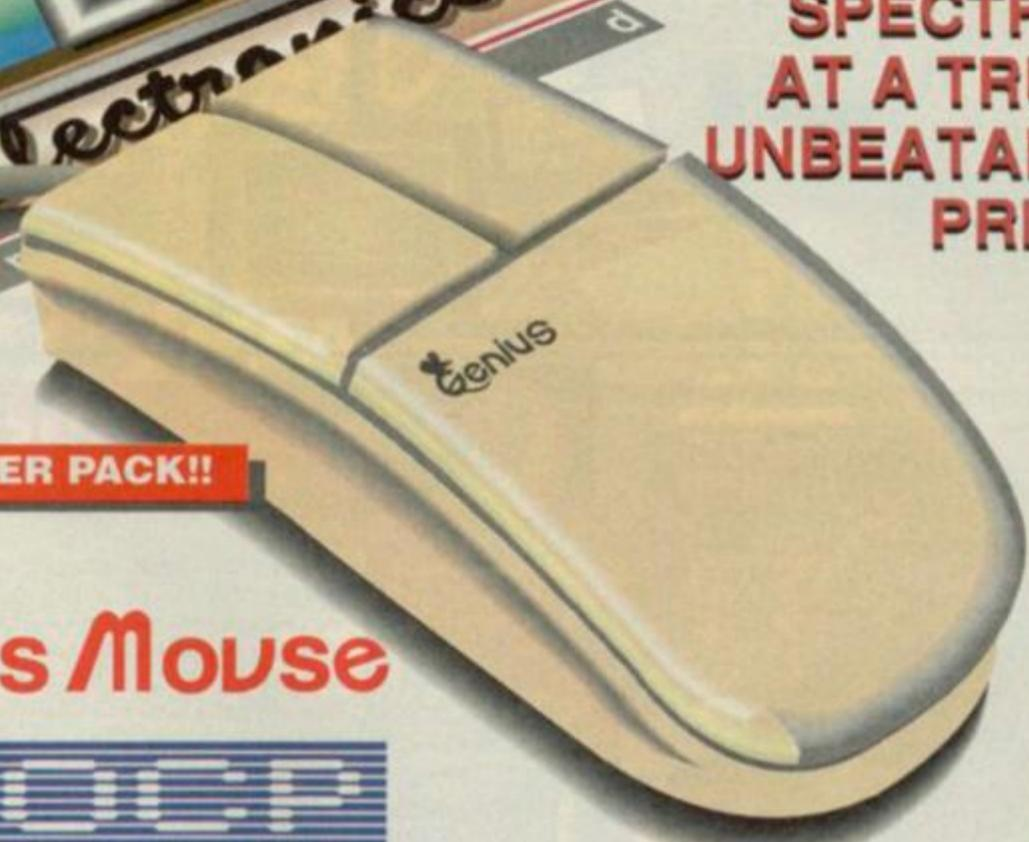

SPECIAL OFFER PACK!!

Genius Mouse

COMPLETE
WITH

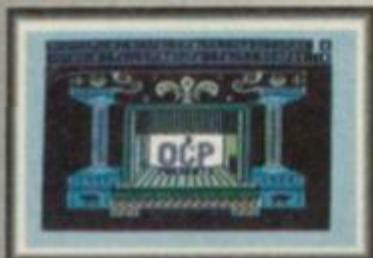

- Genius Mouse is a high resolution two button mouse featuring optical counting, teflon guides, microswitches, rubber coated ball and high quality interface.
- When combined with OCP Advanced Art Studio this graphics package is quite simply the best system available. The features are unmatched...
- Create an image - shrink it, expand it, move it, rotate it, copy it, colour it, etc., etc.
- Spray patterns or shades, make elastic lines - stretch and manipulate shapes.
- Zoom in to add detail in fine mode. ● Pulldown/Icon driven menus for ease of use.
- Mouse operation, plus joystick and keyboard control.
- 16 pens, 8 sprays, 16 brushes - so flexible anyone can create superb graphics easily.
- Full cut and paste facilities plus excellent printer support.
- Mouse Interface even has a built-in Joystick Port (Kempston compatible). Accepts any 9 pin Joystick.

AVAILABLE FOR 48K/128K/+2/+2A/+3 COMPUTERS
(PLEASE STATE WHICH WHEN ORDERING)
NOTE THAT THE +2A COMPUTER HAS A BLACK CASE
UNLIKE THE +2 WHICH HAS A GREY CASE. IT IS
IMPORTANT TO STATE EXACTLY WHICH MODEL OF
SPECTRUM YOU HAVE WHEN ORDERING.

**ONLY
£49.99**

**TOTAL PACKAGE
INCLUDES GENIUS MOUSE,
INTERFACE, OCP ADVANCED ART
STUDIO PLUS FREE MOUSE MAT
AND HOLDER**

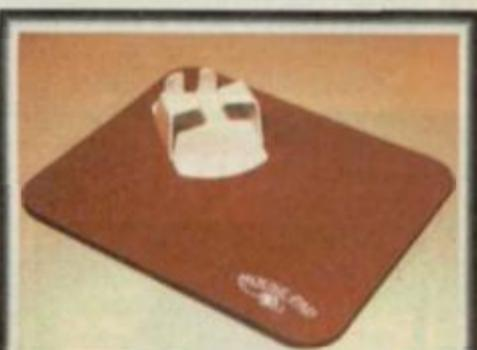

FREE!
**MOUSE MAT AND
MOUSE HOLDER**
(WORTH £12.99)
WITH EACH PACKAGE



NEW

LC 200 COLOUR PRINTER PACKAGE

NOW YOU CAN PRINT OUT YOUR PICTURES IN FULL COLOUR!

- The Star LC200 Colour Printer not only prints in Near Letter Quality for your regular jobs but also prints out your pictures from Art Studio, etc., in genuine colour!
- LC200 is a full Centronics printer so it works with other computers (Amiga, ST, etc.).
- Made possible by Datel's unique colour printer driver - now you can have a hardcopy in up to 16 colours!! ● No more to buy - just plug in and print!!

PACKAGE INCLUDES... STAR LC200 COLOUR PRINTER RRP £299.00
CENTRONICS PRINTER INTERFACE RRP £19.99
DATEL COLOUR PRINTER DRIVER SOFTWARE RRP £19.99
NORMALLY £337.98

COMPLETE PACKAGE NOW ONLY £239.00

COLOUR PRINTER DRIVER AVAILABLE SEPARATELY ONLY £19.99

- If you already have an LC10 or LC 200 Colour Printer we can supply the Driver separately.
- Works with LC10, DkTronics Interface, RamPrint or +2A or +3 Printer Port.

HOW TO GET YOUR ORDER FAST!

TELEPHONE [24Hrs] **0782 744707** CREDIT CARD ORDERS

ORDERS NORMALLY DISPATCHED WITHIN 48 Hrs. ALL CHEQUES/POSTAL ORDERS MADE PAYABLE TO...



DATEL ELECTRONICS LTD.



GOVAN ROAD, FENTON INDUSTRIAL ESTATE, FENTON, STOKE-ON-TRENT, ST4 2RS, ENGLAND.
FAX 0782 744292 TECHNICAL/CUSTOMER SERVICE 0782 744324

DATEL
Electronics

L i m i t e d

SPEC MSE 3

dktronics

Lightwriter™



- Very easy to use - all functions are selected from on-screen instructions.
- Fully Menu driven. Choose inks, papers, erase, fill, etc.
- Top quality interface and lightpen unit complete with software (cassette).
- Save/Load screen images that you have created with your Lightpen.
- Complete with full instructions on its installation and use.
- Highly reliable design - many thousands have already been sold.
- This unit is attractively styled in computer colours to integrate perfectly with your computer system
- Animate several screens in the computer's memory.
- Comes complete, ready to go. Plugs neatly into rear of Spectrum.

COMPLETE SYSTEM
LIGHTPEN/INTERFACE/SOFTWARE ONLY £15.99



music machine

- It's a full sound sampling system allowing any sound to be recorded digitally into the computer RAM. Once stored, the sound can be replayed at different pitches with many varying effects.
- It's an echo chamber & digital delay line. Create some very interesting effects.
- It's a two voice music/sound synth.
- The Music Machine can also be used as a drum machine - eight drum sounds are already provided for you, but you can easily produce more of your own.
- The extremely powerful software allows you to compose tunes from individual bars of music. You can edit your creations on screen & Save/Load sounds, instruments & rhythms.
- Fully MIDI compatible. The Ram Music Machine supports full MIDI In, MIDI Out & MIDI Thru.
- Output through your Hi-Fi or Headphones. Comes complete with microphone.
- Use a full size MIDI keyboard to play the Music Machine.
- Sounds produced by the Music Machine can be mixed with a MIDI synthesiser's own sounds.
- On screen Sound Editor can produce MIDI data from your own compositions.
- Various sampled sounds are provided in order to get you going.
- No other product can offer so much in one unit - it's the TOTAL SOLUTION!!

ONLY £49.99

SPECDRUM



- Now you can turn your Spectrum into a real Digital Drum Machine.
- SpecDrum from Cheetah Marketing is a superb plug in device that produces "real" drum sounds via its unique digital system.
- On screen menu driven drum kit makes composing drum sounds easy for anyone to do!
- Just plug the output into your Hi-Fi, cassette player, etc. and that's it - your Spectrum is a drum kit!!
- Comes complete with DrumKit Sound plus extra DrumKit and Kit Editor Program (worth £9.99) absolutely FREE!!

ONLY £14.99

IMPORTANT

PLEASE STATE FOR 48K/128K/-2/-2A/-3 COMPUTERS WHEN ORDERING NOTE THAT THE -2A COMPUTER HAS A BLACK CASE UNLIKE THE -2 WHICH HAS A GREY CASE. IT IS IMPORTANT TO STATE EXACTLY WHICH MODEL OF SPECTRUM YOU HAVE WHEN ORDERING.

dktronics



PARALLEL/CENTRONICS PRINTER INTERFACE

- Now you can connect most full size parallel printers to your Spectrum.
- Fully re-locatable controlling software (cassette).
- Supplied with Interface with most software using the printer channel e.g. Tasword, Devpac, etc.
- LList, LPrint supported & HiRes screen dump (Epson).
- Comes complete with printer cable - no more to buy!

ONLY £19.99

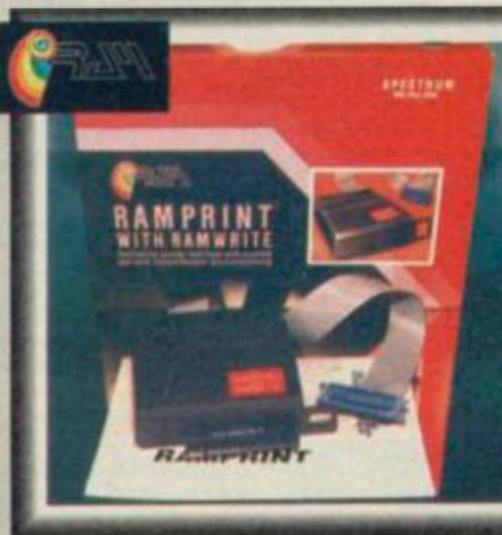

RAMPRINT™

THE ULTIMATE PRINTER INTERFACE WITH BUILT-IN WORDPROCESSOR... NO SOFTWARE TAPES TO LOAD!!

- Works with most any full size Centronics printer.
- Huge range of printer driver options for maximum compatibility.
- Software on ROM - just power up & go!
- Even has built-in joystick interface (Kempston).
- Comes complete with printer cable - no more to buy.

PLUS A SUPERB WORD PROCESSOR...

- Not only are the printer drivers in ROM - the RamPrint even has a wordprocessor built-in!! Just power up & type.
- Full range of wordprocessor commands without the need to load anything.

ONLY £34.99 NO MORE TO BUY!!

HOW TO GET YOUR ORDER FAST!

TELEPHONE [24Hrs] **0782 744707** CREDIT CARD ORDERS

ORDERS NORMALLY DISPATCHED WITHIN 48 Hrs. ALL CHEQUES/POSTAL ORDERS MADE PAYABLE TO...



DATEL ELECTRONICS LTD.



GOVAN ROAD, FENTON INDUSTRIAL ESTATE, FENTON, STOKE-ON-TRENT, ST4 2RS, ENGLAND.
FAX 0782 744292 TECHNICAL/CUSTOMER SERVICE 0782 744324

DATEL

Electronics

L i m i t e d

JOYSTICK

Super Deals



Turbo III
Quick Shot
PYTHON 1

ZIPSTIK

JUST LOOK AT THESE JOYSTICK/INTERFACE DEALS!!

QUICKSHOT Probably the best selling joystick in the world. Over 20 million sold.

- Trigger and Top Fire Buttons for extra quick action.
- Four suction cup base to facilitate one hand action.
- Auto Fire feature - switch on/off.
- Superbly styled with extra long lead.

ZIPSTICK "Tripple action" Auto-Fire makes this probably the world's fastest rapid fire joystick!

- Eight way Micro switches for greater precision and higher scores.
- Superbly styled with extra long lead for comfort whilst playing.
- 12 month guarantee. 90% British made.



STANDARD (KEMPSTON) INTERFACE

SAVE UP TO 40%

- Full Kempston compatibility.
- Superbly styled.
- Fits snugly into your Spectrum (all models).
- Accepts all joysticks with standard 9 pin plug.
- Supports rapid fire.



TURBO DUAL INTERFACE

- The Ram Turbo is a Dual Port Interface accepting up to 2 joysticks.
- Supports all formats - Kempston, Cursor and Interface II.
- Built-in reset switch with player option for two player games.
- Works with any standard 9 pin joysticks including rapid fire.
- Superbly styled to match your Spectrum (not suitable for +3).

OFFER #1
JOYSTICK INTERFACE PLUS
QUICKSHOT PYTHON 1
ONLY £13.99

OFFER #2
JOYSTICK INTERFACE PLUS
ZIPSTIK
ONLY £18.99

OFFER #3
RAM TURBO INTERFACE PLUS
QUICKSHOT PYTHON 1
ONLY £18.99

OFFER #4
RAM TURBO INTERFACE
PLUS ZIPSTIK
ONLY £22.99

HOW TO GET YOUR ORDER FAST!

TELEPHONE [24Hrs] **0782 744707** CREDIT CARD ORDERS

ORDERS NORMALLY DISPATCHED WITHIN 48 Hrs. ALL CHEQUES/POSTAL ORDERS MADE PAYABLE TO...



DATEL ELECTRONICS LTD.



GOVAN ROAD, FENTON INDUSTRIAL ESTATE, FENTON, STOKE-ON-TRENT, ST4 2RS, ENGLAND.
FAX 0782 744292 TECHNICAL/CUSTOMER SERVICE 0782 744324

DATEL
Electronics

L i m i t e d

REPLAY

For keeping out of the radish patch, YS can offer the best in re-released software as a generous consolation...

SUPERHEROES

Domark/£14.99 cass

ComPilation

70°

Oh, blimey. This is a compilation, and it features four superheroes. Um... (They've been brought

together for the first time in one pack and the question on everyone's lips is, will they burst out and explode into action, or just make their excuses and go home on the bus? Ed). Gosh, thanks Mighty Intro Man. (Just in the nick of time.)

Last Ninja 2

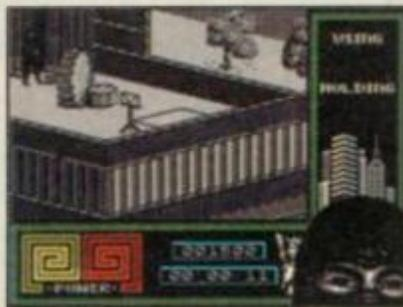

Crufts Supreme Champion, Windsor Brown Frampton, a Great Dane, with his owner, Mr Fido.

Dress in black and lurk behind trees as you play a sinister assassin with severe personality problems. In the game that was a hair-breadth away from being called *The Last-Ninja-Apart-From-This-One-And-Possibly-A-Few-Others-Of-Course*, you've been transported to modern-day New York and have to scurry around, bashing villains and



The moment of glory - Italy finally manage to put three stoats on the moon. (Picture by Snowdon.)

CARTOON COLLECTION

Codemasters/£14.99 cass

ComPilation

91°

Michael Aspel (leaping out from under nearby table): Yes, you thought that you'd walked into this branch of McDonald's for a Big Mac, Large Fries and a Coke but no, Richard and David Darling, the founders of Codemasters, this is (broad grin) your life...



Dizzy

(Back in the studio):

First to see you tonight is that game which spurned a thousand (divided by 200) follow-ups. It was the first arcade adventure to create that unique CodeMasters' feel and was well worthy of its rave reviews. But I'm afraid to say that since then it has been greatly surpassed in graphic, sound and playability departments. It's a shame we couldn't have had one of its follow-ups with us this evening instead. 59°

Slightly Magic

Do you recognise these quotes? "Better than the *Dizzy* games", "Probably due to the addition of spells as well as objects; you have to think quite a lot more about what to do, rather than simply using the correct object in the correct place", "And the graphics and presentation are excellent too", "In fact, all in all, *Slightly Magic* is, well, absolutely 'magic'

solving extremely well-designed puzzles. The 3D graphics are sharper than a bucket of razors and the clever, addictive gameplay is only slightly spoiled by the amazingly tricky controls. Tough, but fun. 83°

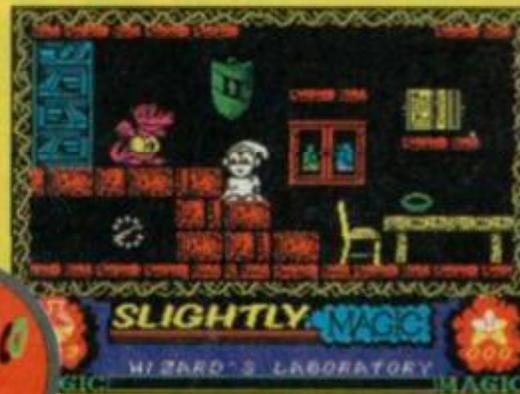

Captain Johnson hands his pipe to Susan, proving both his arms still work.

really." Yes, that was *Your Sinclair* talking about our old friend *Slightly Magic*. And here he is... (clap clap). 94°

Spike In Transylvania

And please welcome *Spike In Transylvania* (applause): You'll have to sit on this special 3D sofa if you will Spike, which we've moved into the studio specially to accommodate the fact that you are the only 3D game here tonight. You are still a good old cartoon puzzle game of course, so don't feel too left out. 84°

CJ'S Elephant Antics

(Michael looks anxious): All the games tonight have been classic flip-screen arcade adventures, maybe all a bit too similar for my liking. So a bounce around platform game



Both Sir Hilary and her husband Tim are allergic to cauliflower, as this 1877 woodcut shows.

Strider 2

More of the same from the Lionel Blair of Speccydom, as *Strider* leaps, springs and somersaults his way through five alien-packed levels. There's a bit of colour, snazzy graphics,

which is easy on our brains could be what we're looking for here. Sort of like a scrolling *Rick Dangerous*. And maybe with a few elephant references. In fact, I don't think that I'd even mind if it had atrocious scrolling, blurry graphics and a crap two player mode. Hmm. 84°

Seymour Goes To Hollywood

Unfortunately Bernard Manning wasn't able to be with us tonight, so he made this video earlier.

"Hi there. Bernard Manning here. I'd just like to say what a great game *Seymour Goes To Hollywood* is. It's brand spanking new, it still plays like *Dizzy* but what the heck, eh? Seeya." 90°



Noel Edmonds, in a chiffon diving suit, enters the jacuzzi in a direction he invented himself during the Falklands Conflict.

And that's the end of the show, and the end of my crap review which wasn't even funny. A great compilation all in all; the only snag lying in the fact that all the games are a teensy weensy bit the same. It's still great val for mon if you haven't got any of the games though. (Bit unlikely. Ed) Rich

and this time ol' rubber limbs twirls both a sword and a laser pistol. Playable stuff, though it's not as hot as it should have been, and a let-down when compared to the original. 70°

Top Ten Essentials for Super-heroes

- The snappy name
- The catch phrase
- The prop
- The sidekick
- The mortal enemy
- The shadowy past
- The smirk
- The disturbed tailor
- That indefinable something
- The merchandising

The Spy Who Loved Me
A clone of the rather-James-Bondish-anyway *Spy Hunter*, *The Spy Who Loved Me* is far more polished than its predecessor. It adds to the formula such things as narrower, twistier roads, a wider range of power-ups and pedestrians. Unfortunately, all the extra features piled on top of the basic shoot-'em-up idea sort

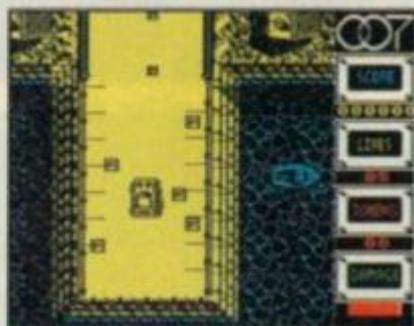

Keeping the pot steady, increase the speed of the wheel until clay flies in all directions. Et voilà!

of swamp the game itself. Fair, but not a patch on the wrinkly original in terms of playability. 61°

Indiana Jones And The Last Crusade

A spanking arcade-adventure with tasty graphics, this was covered as a re-release in issue 71. I wrote the review then and I can't be bothered to say it all agin. I still like it a lot, in fact, I've got onto level three since, so I'll give it an extra degree! 80°

Not an overly inspiring compilation. *Strider 2* is disappointing, and *Spy* knocks



Prince Charles, in full Royal regalia, opens the first Spud-U-Like on Sark. He is watched by Leslie Crowther and Pip.

the overall rating down quite a bit. Only for those who don't have any of the games already, methinks. Jon ○

SWITCHBLADE

Gremlin/£3.99 cass

Aha! I've been waiting for this to appear on budget. The last time we saw *Switchblade*, it was in issue 63. Andy Ide (that old hippy, remember?) gave it a Megagame and 92°. And it well deserved it.

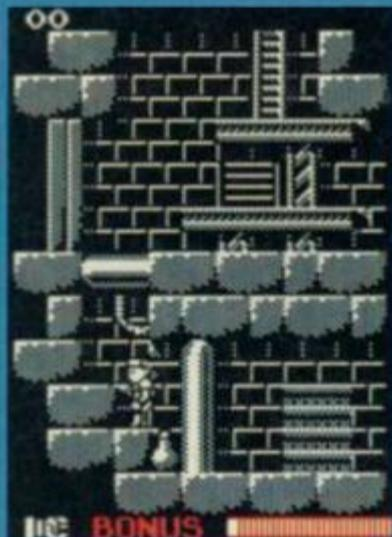

Marky Mark is currently appearing as Widow Twanky in *King Lear* at the Playhouse.

The idea of the game is to explore a load of underground passages and chambers, populated by baddies, traps and various other sorts of unpleasantness.

You play a little character called Hiro, who happens to be in the special *Switchblade* gang. Everything was going brilliantly until a dude called Havoc wandered along and nicked your sacred Fireblade thingy. Fed up, you decide to go and get it back. Or rather get all the bits of it back.

because as he half-inched it, Havoc managed to bust it into 16 pieces. Silly fool. So you wander along the surface of this weird planet until you come to a mineshaft. Drop down and you're into the realm of the *Switchblade*.

Instead of the usual fighting techniques, *Switchblade* forces you to learn a whole new system. You've got a power meter which, if you hold down the fire button, winds up to full strength. When you release the button, Hiro kicks out with all his might. Aliens, stoneware bottles and even some sections of wall will fall apart when this happens. This method of doing violence takes a wee bit of getting used to, but once you've mastered it, Robert is your father's brother.

As you chug along, each section of the

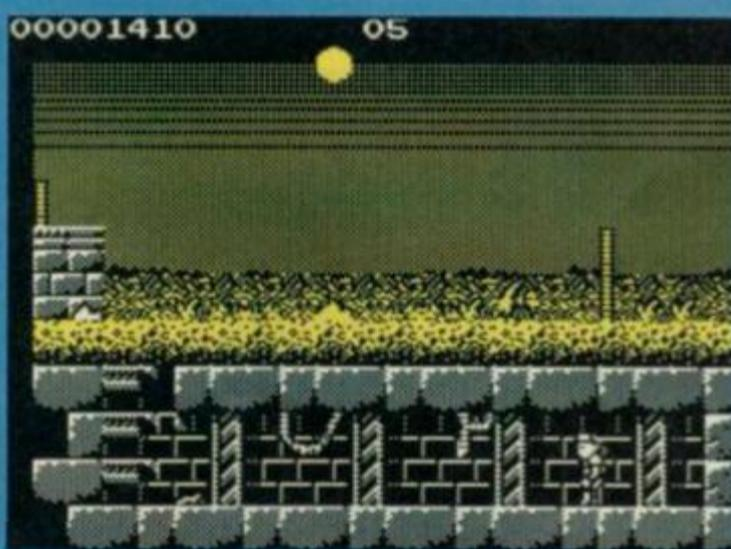

Follow this diagram for removal of the carburettor. Make sure you keep your hands clear of the helicopter's spinning blades.

labyrinth reveals itself out of the darkness bit by bit. It's a clever little device, and makes *Switchblade* dead atmospheric. You're never quite sure what will be round the next corner. It could be a secret cavern, it could be a massive alien or it could be Jeremy Beadle in a stupid disguise, trying not to snigger.

But, we have to ask ourselves at some point on our long quest-like journey, what makes *Switchblade* a spectacular and entertaining

game? Why do I enjoy playing it so much? Can we define this so-called quantity of 'playability' in spatially aware terms?

The answer is, er, yes and no. Probably. *Switchblade* is a most excellent game because it's tough but not too tough, it's fast and smooth, it's got loads and loads of rooms and it's dead satisfying to

explore. I mean you wouldn't believe the number of *Switchblade* maps we've been sent by you lot. It just goes to show, doesn't it?

Finding the bits of your sword will keep you glued to your screen for ages, mind. This is one big game. How they managed to cram it into only one Speccy will forever remain a mystery, unless the programmers decide to tell us. There are plenty of dead ends, loops and false corners, so prepare to be frustrated as well.

If you're into high-quality platform games, you'll probably be the proud owner of *Switchblade* already. If you haven't got it, the best thing to do would be to rush out to your local bakery, go into the cooling room and check underneath all the freshly-made baps for a copy of the game. Also, while you're there, could you pick up a French stick for the Shed?

Yep. *Switchblade* was a Megagame before and it's a Megagame again. Three loud cheers for it! James ○

MAKE YOUR OWN SWITCHBLADE

1. Using an industrial laser beam, carefully etch out the shape of the blade you've chosen into some high quality Swedish steel.
2. Set up a metal-cutting lathe (you'll find one at the Ford factory in Dagenham).
3. Carefully cut round the etch-line you made with the laser. If you make a mistake now, you'll have to do it all again.
4. Smooth the blade with a sand-blaster, and gently lathe the sides into razor-sharp cutting edges.
5. Fashion a handle out of finest Madagascan ebony, edge it with gold leaf and – hey presto! A *Switchblade* fit for presentation to the Royal Family!

The Hi Tec Hanna-Barbera Cartoon Character Collection

Hi Tec/£9.99 cass

ComPilation

I was jolly pleased when I received this compilation as I'm a big fan of the original Hanna-Barbera television cartoons, even though they did give today's companies an excuse to have shows consisting of people standing around blinking. In fact, I'm really looking forward to the review! They do say there's a first time for everything. (You're fired. Ed)



Simon Le Bon, relaxing on his yacht with two Pandas he liberated from Chester Zoo yesterday. He later returned them unharmed.

Top Cat

Did you know that the BBC still insists on calling this show Boss Cat even though the makers of Top Cat cat food have gone bust, or changed their name to Garfield Munchies, or something? Fascinating, eh? Ah well, onto the game itself. The plot is actually rather interesting, with wily old TC offering Benny the Ball to a millionaire as his missing heir, unaware that the scheming butler and his smirking dog have their eyes on the legacy as well. Seizing both their chance and Benny, the two spirit him away to a place of ingenious concealment in an effort to thwart TC's plan. Rightly indignant, and pausing only to round up the rest of his gang (Choo Choo, Spook, Fancy, Brain, Spam, Sleepy, Doc, Rik, Vyvyan and Spam), this Bilko of the back-alley dustbins sets out to save the day. Graphics throughout are spot on, the characters are instantly recognisable, the backgrounds smartly coloured, and TC himself doesn't walk, he strolls. Nonchalantly.

The game though is something else. It's a flip-screen collect-'em-up affair, with keys to grab and nasties to dodge, and it has all the playability and addictive qualities of the embarrassingly similar *Yogi Bear And Friends In The Greed Monster*. In short, the kind of game you could forget to load and not even notice.

30°

Hong Kong Phooey

The pooch who does for kung fu what Jacques Clousseau did for Karate, Hong Kong Phooey battles crime with a steely heart and a stony head. In the game, a particularly ridiculous baddy has escaped from prison, and our hero has been called in to fetch him back. No doubt you'll be delighted to learn this isn't a maze game; it's

a scrolling beat-'em-up with overtones of *Robocop*, as well-drawn sprites knock each other off walkways. The trouble is, there's no variety to the gameplay, and while the playing area is commendably large, the difficulty level is much too high. Henchmen and spike traps are everywhere, with each mistake costing you whopping chunks of energy. A pity, as it means the initial playability is quickly beaten down by frustration. Aw, Phooey.

41°

Yogi's Great Escape

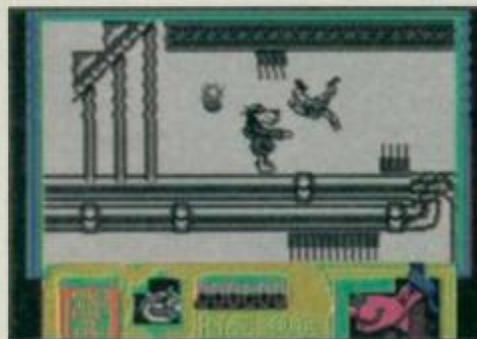

John is shocked at the mysterious disappearance of his submarine. He later realised he'd left the keys in it.

From the cartoon co-starring Boo Boo and Donald Pleasance, this game charts the adventures of the brainy bruin after he discovers Jellystone Park is to close. Deciding to have it away on his toes rather than be banged up in a zoo, Yogi stuffs his faithful compatriot into a picnic basket and dashes off through six levels of magnificent countryside. Dogging his heels are dogs (natch), hunters,

Ten Things Hanna-Barbera Gave The World

- Tom and Jerry
- The Flintstones
- Cartoon Laugh Tracks
- The impression they were women
- The Muttley snicker
- The familiar background play
- Officer Dibble
- Appaling 1980s versions of their shows
- The Rubik cube
- But only one they'd bought at Woolworth and got fed up with

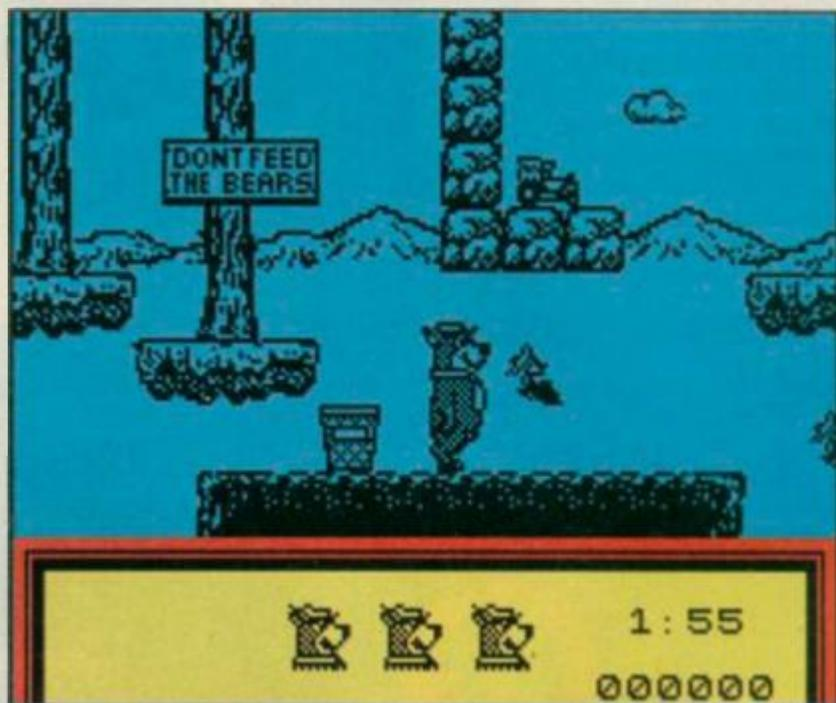

Laurence Whelk gives a reading of his latest poem, *Twisting My Moonlit Pony* before a collection of war criminals at Barnsley Town Hall, famous for its fluted archways and mock-Tudor security video cameras

Ranger Smith and Richard Gibson as the hilarious German officer. (Now you're just being silly. Ed). A dandy little scrolling platform game, *Yogi's Great Escape* is full of moving ledges, optimistic leaps into thin air and hidden bonuses. It's a Bruciel! (You know, "good game, good game"... oh, never mind.)

70°

Ruff And Reddy

Famous as both Hanna-Barbera's first foray into TV animation and as one of the few cartoon double-acts who were pals, Ruff and Reddy have now all but vanished from memory. What a shame. In the game, with a plot taken from their very first show (I think), you play Ruff (an orange kitten with a bow-tie) who's managed to crash-land the space rocket both you and Reddy (a big white dog) have stowed away upon. A group of aliens are holding onto Reddy until you save some of their number who have been kidnapped by another bunch of extra-terrestrials. (Crikey, no wonder people don't remember these cartoons.) What it all boils down to is a platform game suspiciously like *Yogi's Great Escape* in style, with more than a hint of *Top Cat* in the graphics

(Ruff ambles along in exactly the same way as TC). Unlike Yogi however, this is decidedly average, not terribly exciting and with confusing flip-screen presentation. Rough and weedy.

40°

None of the game have any of the cartoons' atmosphere, *Yogi's Great Escape* is good fun but has virtually nothing to do with the character himself. They fail miserably in recognising the potential of the licences; the 1960s Hanna-Barbera cartoons may have had limited animation, but they were hammed with gags and ideas. This compilation is just the opposite; the graphics are uniformly excellent, but there's no attempt to be innovative and, for the most part, no content to the games. Insultingly poor. Jon



Close examination shows the soil structure to consist of broken down Nintendo games, some still unused.

Staff Writer

- Founded in 1985
- Now over 250 staff
- 16 national news-stand magazines
- Market leader in computer titles
- Exciting launch plans
- Britain's fastest-growing publisher

Salary negotiable

Right you lot. Everyday we get sacks of letters from Speccy fans who'd like nothing better than to work for Your Sinclair, the best Speccy magazine in the known universe. Well now's your chance. We're on the look-out for a gifted writer to join the YS team. Ideally you should have:

- a working knowledge of the Spectrum scene
- the ability to write lively, readable copy
- the personality to fit into a dynamic team
- the desire to live in beautiful Bath
- a PhD in quantum physics would be nice, but we'll settle for GCSEs, A'levels or a degree!

If you think you've got what it takes to work for one of Future's biggest selling magazines, then we'd like to hear from you.

You too can find happiness the YS way. Linda was an ordinary teenager, hopelessly devoted to her lichens and mosses. Then she heard about a job opening on YS and was soon living a life of joy and happiness in sweltering Bath. Linda says,

"My lichens have never been happier than since I joined Your Sinclair."

Send a letter of application; a CV; and either a 300 word review of any Speccy game or samples of any published work - to **Andy Hutchinson, Editor: Your Sinclair**, at the address below.

Future Publishing Ltd, Beauford Court, 30 Monmouth Street, Bath, BA1 2BW Tel: (0225) 442244

RADICAL TURTLES OFFER!

The turtles haven't forgotten their fans! You see, just the



other day we got a fax through from

California from none other than the fab four Teenage Turtles. The half-shell heroes had seen the turtley awesome cover of the December



issue and decided that they'd help out their British fans. Hence this wicked offer!

If you buy the *Teenage Mutant Hero Turtles: the Coin-op* game from us, we'll throw in the Teenage Mutant Ninja Turtles movie for free, that's a saving of a ten squid! So, if you want the cassette version of the game, send us £11.99 and if



you want the disk version send us £18.99.

Remember, we can only afford to do this thanks to the amazing generosity of the turtles themselves, so don't be square, get some hair, oh yes and buy a turtles video/game pack while you're

Buy Turtles the Game, get Turtles the movie absolutely free!



NAME.....	DESCRIPTION	PRICE	QTY	TOTAL
ADDRESS	VIDEO/CASS PACK	£14.99		
.....	VIDEO/DISK PACK	£18.99		
.....	TOTAL ORDER			<input type="text"/>
POST CODE				
PHONE NO.....				
METHOD OF PAYMENT (PLEASE CIRCLE)	ACCESS	<input type="radio"/>	VISA	<input type="radio"/>
	CHEQUE	<input type="radio"/>	P/O	<input type="radio"/>
CREDIT CARD NO	<input type="text"/>			
EXPIRY DATE	<input type="text"/>			

PLEASE MAKE ALL CHEQUES PAYABLE TO FUTURE PUBLISHING LTD
 SEND THIS FROM TO: YOUR SINCLAIR TURTLES OFFER, FUTURE PUBLISHING LTD, SOMERTON, SOMERSET, TA11 7BR
 No stamp is required if posted in the UK, Channel Islands or the Isle of Man
 For Overseas orders call 0458 74011 for prices.

HOTLINE 0458 74011

BENTLEYS

251 NEWCASTLE STREET
BURSLEM
STOKE ON TRENT
STAFFS
ST6 3QW
TEL: (0782) 810485



**5 FREE GAMES
WITH EVERY REPAIR (TAPE ONLY)**

REPAIRS

48K Spectrum.....£20.00
128K Spectrum.....£22.00
Excluding disk drive and tape assembly
Our offer prices are for mail order only.

SPARES

48K Keyboard Membrane.....£6.00
48K+ Keyboard Membrane.....£8.50
48K Power Supply.....£10.00

ALL PRICES INCLUDE VAT AND
RETURN (INSURED) POST AND
PACKAGING

24hrs Repairs

EEC LTD.

SINCLAIR PRODUCTS & PRINTERS

*QL £125 SPECTRUM +2 £90 SP+3 £95

*INCLUDES FREE QUANTA MEMBERSHIP
MICRODRIVE EXPANSION KIT

Includes microdrive, interface 1, booklet, introduction cartridge & flex connector.....£59.95
As above with extra microdrive.....£69.95
NEW Microdrives.....£24.95

CARTRIDGES

Wallet of 4.....£18.00 box of 20.....£55.00 Reformats 10 for.....£18.00

POWER SUPPLIES: 48K - £7.95, 128K +2 - £9.95, +2A & +3 - £15.95

14" COLOUR MONITORS

Sinclair S14 black.....£99.00 Philips 8833 MK11 grey/sound.....£279.00

* OUR PRICES NOW INCLUDE 17% V.A.T *

80Col PRINTER FOR SPECTRUM & QL

Seikosha SP1900 9 pin dot matrix, up to 192 cps, FX850 emulation.....£130.00
Canon BJ10e bubblejet, very high quality (360dpi), A4 size.....£259.00

We can supply any make/model printer - please ask for details.
QL/Spectrum spares & repairs - please ask for details.

'UNIVERSAL' 3.5" DISK DRIVE

1Mb 3.5" cased, complete with built-in PSU, mains switch & 13 amp plug.
EXTERNAL dip switches adapt drive for Spectrum, QL, PC, Atari, Amiga etc.
Comes with full instruction book, plastic cover and free DS/DD disk. Spectrum
& QL need I/Face, lead free.....(P&P £6) £75.00
Additional leads.....(P&P £3) £12.00
Bare 3.5" 1Mb d/drives.....Epson Low Profile 1".....(P&P £3) £39.00

UK delivery: Please add £9 for PRINTERS and micros. Other items £3.
Outside UK add £15. Other items £5. C.W.O. OR VISA/ACCESS.

ALL OFFERS SUBJECT TO AVAILABILITY.

SOME PRODUCTS MAY BE RECONDITIONED. ORDERS TO:

EEC 18-21 MISBOURNE HOUSE, CHILTERN HILL,
CHALFONT ST PETER, BUCKS SL9 9UE



FAX: 0753 887149

TEL: 0753 888866



SAMTAPE 4M

- * MAKES SAM ACT AS A SPECTRUM
- * WORKS ON MOST PROGRAMS
- * EASY COPY PROGRAMS TO DISK/TAPE
- * ACCEPTS +D/DISCIPLE SNAP SHOTS
- * EMULATES TASWORD 2, DTP BY PCG
- * LLIST+LPRINT.ETC. ALL KEYS WORK
- * SCREEN COPY, SEARCH, ETC.
- * FILE COMPRESSION - SAVES 10-60%
- * CHANGE PALETTE COLOURS.
- * CONVERTS MESSENGER FILES INCL COMPRESSION - SAVES 25-90%

ROM2 + DISK ONLY - COST £11.99

SAM ASSEMBLER 3

ASSEMBLER - FULL SCREEN EDITOR, AUTO TAB, LIST LABELS, HEX/BIN/DEC, DUMPS, PRINTER, ERROR MESSAGES ETC. INCLUDES DISASSEMBLER + MONITOR/SINGLESTEP TO DEBUG CODE. 64 COL SCREEN. SCRATCH PAD. INCL 256+512K VERSIONS £10.99



SAMDISK2

IMPROVED + A MUST FOR ALL DISK OWNERS. HAS EASY TO USE DISK MANAGEMENT TOOLS LIKE REPAIR, SUPERB FILE COPIER, PLUS MANY HANDY EXTRAS TO DELIGHT YOU! 256+512K SAMS. ONLY £11.99

- * V.FAST DISK DUPLICATOR - 2 DRIVES
- * IMPROVED REPAIR/VERIFY TRACKS
- * IMPROVED V.FAST FILE COPIER
- * MAX 5 SWOPS FOR FULL DISK
- * ERASE, UNERASE, NAME DISK, MOVE.
- * INFO TO TV/PRINTER, SQUASH, FILL.
- * UNFORMAT/FORMAT TRACK.

SAM ADDRESS/PHONE MANAGER

5000 ADDRESSES AND/OR PHONE NUMBERS A DISK. SEARCH/AMEND/ALPHABETIC SORT. PRINT LABELS, ETC. HOME/BUSINESS. £8.50

SAM TOOLKIT

INCL SAM ASSEM.3 + REVERSE ASSEMBLER (MAKES S.FILE FROM CODE), 2ND DISSEM, GUIDE FOR WRITING CODE ON SAM, MEMORY PAGING, ROM/RAM, EXAMPLES, ETC. £14.50

- * SUPERB UPDATE SERVICE
- * MONEY BACK GUARANTEE

SPECTRUM TAPE UTILITY D - TAPE TO TAPE BACK UP OF MOST SPECTRUM PROGRAMS. CONVERTS MANY FOR RELIABLE LOADING - £8.50.

TRANSPACK 2 (TP2) - TAPE TO DISK/M-DRIVE TRANSFER. 1000'S OF PROGRAMS INCL CLUCKY, FIREBIRD, SPEEDLOCK. £11.99 NOT FOR NOVICE. INFORMATION BOOKS 1,2,3, £2.50 EACH. INFO OF 100'S OF TRANSFERS TP2 CAN'T DO AUTOMATICALLY.

Z80 TOOLKIT - "BRILLIANT PACKAGE" - YS 7/88. M/CODE PACKAGE SIMILAR TO SAM TOOLKIT. A REAL MUST! £8.99.

PLUS3MATE AND MICROMATE - SIMILAR TO SAMDISK BUT FOR +3 AND M/DRIVE RESPECTIVELY. WILL CLONE, COPY FILES, SECTOR EDITOR ETC. SUPERB DOCTOR/TOOLKIT. +3MATE £12.99. MICROMATE £11.99

SAM HARDWARE SPECIALS

512K SAM + 1 DISK - £200 INCL SAMTAPE 4 SAM DRIVES, INTERFACES, MESSENGER, ETC.
PHONE FOR SPECIAL OFFERS

UK POST FREE, +£1 EUROPE, +£2 REST. DISKS 3" £2.20 EACH, 3.5" 70P EACH. ALL MIN 4 POST FREE. SAE FOR DETAILS. PROP. LEVANS. TEL (091) 2533615. LERM, DEPT YSX, 11 BEACONSFIELD CLOSE, WHITLEY BAY. NE25 9UW.

KOBRAHSOFT SPECTRUM AND SAM COUPE UTILITIES

SAM DICE DISK UTILITY:- NEW! Version 1.1:- BACKUP; RECOVER erased files/lost data; REPAIR directories; DISK CHECK; LOCK OUT bad sectors; STRING search; Selective FORMAT. Will now handle subdirectories as in MasterDos. Price: £14.95 on Disk

CD2 TAPE TO SAM DISK TRANSFER UTILITY:- NEW! Transfer the VAST MAJORITY of your Spectrum tapes to Sam drive. Gives superb Spectrum tape compatibility. VERY EASY to use. Price: £10.95 on Disk.

SP7 TAPE TO +3 DISK UTILITY:- NEW! Transfer tapes to +3 disk. Now comes with a BEGINNER'S Manual, an ADVANCED User Manual, and an Encrypter Demo Tape. Also has a superb DISK CATALOGUER, and now will transfer FULL 128K programs. INCLUDES SP7 COMPANION - shows how to transfer many games. Supplied on Disk at:- £14.95.

SP7 COMPANION VOL 2:- TRANSFERS 100+ GAMES. Needs SP7:- £4.95 SC7 UTILITY. NEW! Latest tape to tape backup utility will now backup virtually ANY program. Price:- £9.95 on Tape.

DMS +3 DISK MANAGEMENT SYSTEM:- NEW version 1.1 now with printout, high capacity formats AND extended directories. Organise all your disk files. Large database, FAST file search. MENU programs. Easy to use:- £14.95 on Disk.

D.J.C.E:- NEW Version 3.0 +3 disk utility. Now with high capacity format, data printout and disassembler. Lock out faulty sectors; Recover erased files and much more. Easy to use. "An excellent Package". CRASH Oct '88. £14.95 on Disk.

SPECTRUM MACHINE CODE COURSE:- FULL course from beginner to advanced level. Applies to ALL Spectrums. Suitable for all. Free Disassembler AND Editor/Assembler:- £20.00.

SAM Z80 MACHINE CODE COURSE:- NEW! Learn how to program your Sam in machine code. Full course suitable for all, with an assembler and disassembler. Price :- £20.00.

PLUS 3 DIARY AND FILING SYSTEM:- NEW Version 1.1 with full printout. Superb filing system/diary for the +3 with LARGE database, fast search/retrieve, biorhythms:- £12.95 on Disk.

ALSO AVAILABLE:- SD5 TAPE TO M/D; SO5 TAPE TO OPUS; MT1 M/D TOOLKIT; SW1 TAPE TO WAFADRIVE; SAM CT2 TAPE UTILITY; SM1 M/F SUITE; DB2 +3 DISK BACKUP UTILITY.
Ring for full details.

WE OFFER A FULL MONEY BACK GUARANTEE - BUY WITH CONFIDENCE
UPDATE SERVICE:- SEND HALF NEW PRICE + OLD DISK FOR NEW VERSION.
Send Cheque/P.O. to:- "KOBRAHSOFT", DEPT YS, "Pleasant View", Hulme Lane, Hulme, Longton, Stoke-on-Trent, Staffs. ST3 5BH.
(Overseas:- EUROPE add £1 P&P PER ITEM, others £2) Send SAE (9" X 5") for detailed Catalogue - mark envelope "ENQUIRY".



For more information please phone:- 078 130 5244
Access, Visa welcome - please phone above number
(24 Hour, 7 Day Service for FAST Mail Order).



WANTED



USE YOUR VOICE TO OUTDRAW THE GUNFIGHTER

DEAD OR ALIVE CASH PRIZES

0898 313591

TREASURE ISLAND



USE YOUR VOICE TO LOCATE THE TREASURE

0898 313586

If you are under 18 years of age please obtain permission of whoever pays the phone bill. INFODIAL PO Box 36 L51 4TN Call charges 36p Per Min Cheap 48p Per Min All Other Times



ALIENS

Can You Kill The ALIENS For CASH PRIZES

0898 313 585

Infodial PO Box 36 L51 4TN Call Charges 34p Per min Cheap Rate 45p all other times

P.C.G.

61 School Street
Barrow-in-Furness
Cumbria
LA14 1EW



Spectrum & SAM Software:

WordMaster the word processor	£13.95
Headliner graphic & title designer	£10.95
Typeliner desktop publisher	£18.95
DTP Pack (all three above programs)	£37.95
DTP Font Packs now available	£7.95
Font Packs #1 and #2	£12.95
Art Disks for SAM/Disciple & Plus D	£4.00
Prices for tape or 3.5" disk. For +3 disk add £2.00	

Dot-Matrix Printers:

Citizen 120-D high quality NLQ printer	£150
Star LC10 superior quality, many features	£170
+3/+2A Cable: £10.95 48k/128/+2 Interface: £25	

All printers are compatible with the DTP Pack.

Atari ST Computers

520 STFM Discovery Pack with 4 games	£279
520 STE Power Pack with 20+ ST games	£369

●●● FREE UK delivery on all items! ●●●

Want more details? Send a S.A.E. now or Phone 0229-836957

The DTP Pack

With the DTP Pack and an ordinary dot-matrix printer you can produce letters, signs, leaflets - even your own newspaper! The most powerful suite of software available for the Spectrum, for all systems from the 48k to the +3 and SAM!

Atari ST

If you're looking beyond the Spectrum, the Atari ST is the computer to go for. With 512k RAM, disk drive & mouse it's a complete system with hundreds of games, utilities and business software available.

THE "ULTIMATE" PACK £8.99

The ultimate code utility package crafted by a professional. Six programs which will enable you to find infinite lives in games, disassemble code - the scope is limitless. Complete with special instruction booklet featuring expert hints and tips and examples.
SPEEDY LOAD/SAVE - £4.99
Convert your own programs to fast load...
20 CHARACTER SET FONTS - £4.99
INTERRUPT SOUND EFFECTS - £3.99
Create amazing interrupt driven sound effects that run without stopping program execution.

PROGRAM PROTECTION TOOLKIT - £4.99
Expert routines for your programs to protect them from prying eyes. Developed over years...
DRUM BEAT MACHINE - £3.99
Add your own rhythms to your programs!
GAMES AID - £3.99
Toolkit of routines and tips to help creating games.
POKES GALORE - £3.99
MESSAGE SCROLLER - £2.99
DOUBLE HEIGHT PRINT - £2.50
SP1 - DROID - £2.99 LASER WAR - £2.99
Add 50p P&P, unless ordering more than one program.

SIGMASOFT DEPT Y514, 8 PINE DALE, RAINFORD, MERSEYSIDE WA11 8DP

SPECTRUM UTILITIES, SUNDRIES, PC TRANSFER

SPECCIFAX EASY TO USE GRAPHICS PACKAGE - Tape £9.99, +3 Disc £13.99, Microdrive £11.99 Graphics package. Type colour pictures/text, save, retrieve, update, print, single/repeating displays	
COMPLETE MACHINE CODE PACKAGE - Tape £8.95, +3 Disc £12.75, Microdrive £10.75 Assemble, disassemble, test, trace, step, hex, binary, decimal. Unique facilities to teach yourself assembler/machine code, instructions supplied + examples of games screen design/copying games tapes.	
MICRODRIVE MANAGEMENT AND RECOVERY - Copy, sensible CAT, recover corrupt files	£9.75
RAMDOS MICRODRIVE OPERATING SYSTEM - Random access, screen edit, sort, search	£9.75
MICRODRIVE FREE TEXT DATABASE - multi-purpose filing system with search	£9.75
MICRODRIVE CARTRIDGES - New, 4 for £10, 8 for £19. C12 BLANK TAPES with case - 8 for £5.00	
SPECTRUM TO PC DATA AND BASIC PROGRAM TRANSFER SERVICE - Send SAE for details	

S.A.E for leaflets. Tel 0268 780663 for queries. Pay by cheque/PO, post free UK, £1 EEC, £2 world. Roybot Y5, 45 Hullbridge Road, Rayleigh, Essex SS6 9NL

SINCLAIR SUPPLIES

Spectrum +2 Computer	£99.99	4 x CF2 blank discs	£8.00
Spectrum +3 Computer	£99.99	Kempston Joystick Interface	£9.99
Centronics Printer	£119.99	Magnum Lightgun (+2, +3)	£14.99
Spectrum power supply	£13.99	Chestah Lightgun (+2, +3)	£14.50
Spectrum +2A/+3 power supply	P.O.A	Wafa drive cartridges (64k x 2)	£9.98
Membrane (QL, Spectrum 48, +)	£10.99	+2A/+3 printer/scart cables	£9.99
		Spectrum Datarecorder	£19.99

SPECTRUM REPAIRS

ONLY £14.95 FOR 48K or Spectrum + Machines. (phone for +2/+3) includes P&P, insurance etc. Send computer with covering letter. Cheque/P.O to Omnidale Supplies, 23 Curzon Street, Derby DE1 2ES Tel 0332 291219 (24 hour credit card line)

SPECTRUM REPAIRS

48K Plus	£18.00	48K Rubber membranes	£6.00
48K Rubber	£16.00	4116 memory IC	£0.70
48K Plus membranes	£11.00	4164/4532 memory IC	£2.60
Z80 CPU	£2.60		

Minimum order £5. Other spares stocked. Prices include VAT and post.

RA Electronics, 133 London Road South,

Lowesoft, Suffolk NR33 0AX Tel: 0502 566289

SPECTRUM REPAIRS

£16.95 (48K) inclusive of labour, parts and p&p. Fast, reliable service by qualified engineers. Average repair 24hrs. 3 months guarantee on all work. For help or advice - ring:

H.S. COMPUTER SERVICES

Unit 2, The Orchard, Warton, Preston, Lancs PR4 1BE

Tel:(0772) 632686



SPECTRUM REPAIRS

FIXED PRICES FAST TURNAROUND

- * Fast turnaround-typically 24 hour.
- * Competitive fixed prices.
- * 20 qualified technician engineers at your disposal.
- * Commodore/Amstrad authorised and registered repair centre.

* Spectrum 48k:	£21.00
* Spectrum 128k:	£24.00
* Spectrum +2:	£29.00

* All repairs covered by a 90 day warranty.



- * Simply send or hand deliver your machine to the workshop, address below, enclosing payment and this advert, and we will do the rest. (If possible, please include a daytime telephone number and fault description).

- * If you require 24 hour courier to your door, please add £5, else your computer will be sent back by contract parcel post.

(WTS reserve the right to refuse machines that in our opinion are beyond reasonable repair.)

WTS Electronics Ltd, Studio Master House, Chaul End Lane, Luton, Beds LU4 8EZ. Tel: 0582 491949 (4 lines).

MURRAY MOUSE IN MOUSE MANIA

CodeMasters

CodeMasters shockingly call this game 'cheesetastic'. Using such language is enough to put you off cheese (and CodeMasters) for life. But don't worry, it's just their idea of being clever and having fun.

Anyway, Murray Mouse, a newcomer to the cute-cartoon-style-characters-with-humorous-names stable, has discovered that ten members of the evil Moufia organisation have formed a conspiracy to fly to the moon, which they've discovered is made of green cheese. They

then intend to claim the moon for themselves.

Murray, not wanting the world to be held to ransom, sets off on a large and pretty difficult task. He's got to find each of the Moufia members and bring them to justice. That they may not want to be brought to justice doesn't enter into his tiny, rodent head.

Murray Mouse is a flip-screen arcade adventure, with more platforms than Waterloo station. (We did that gag last month, Ed) It all starts above ground, where some chaps called the *Jaking*



Mushrooms live. Murray gets away from all this by going underground to the sewers and mouse houses which he finds below the mushrooms. Weirdness indeed.

Murray, being just a mere mouse, isn't really expected to save the entire world without any help. Luckily there are loads of collectables scattered around to make life a tad easier for him.

He's got big hands for a mouse and can hold up to three things at once, which is useful cos some of the objects hold the key to getting further into it all (if you see what I mean).

Yes, it looks like CodeMasters have combined their usual format of wandering from screen to screen doing stuff with mice and, er, cheese. Hurrah!



How to make cheese.

- Get a load of milk (about half a pint should do).
- Put it in a big jar with a tablespoon of live yoghurt.
- Open the jar, sneeze into it, then quickly close it again.
- Leave it for 6 months.
- Forget about it and move house.
- Get a phone call from the Ministry Of Defence, who've cordoned off your old house, believing it to be a biological test site left by the Russians in World War 2.
- The cheese is now ready to serve.

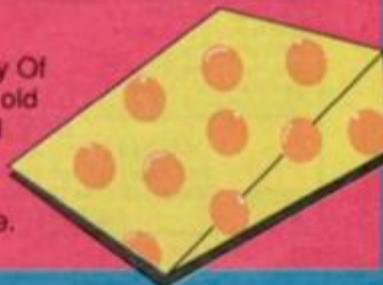

Murray isn't finding it pleasant in the sewers. What he really needs is a good sit-down and a nice slice of Wensteydale Old Veiny. Delicious!

WORLD CUP

D&H GAMES

Just when you thought you wouldn't have to worry about England playing football against anybody else in the world, D & H have come bouncing back with *World Cup*.

I reckon it must be at least two years until the next world cup, and two years since the last one. So basically we couldn't be further from any world cup. Good timing, D & H!

Right, let's forget any nonsense about real world cups and concentrate on this game. Are you concentrating? Good. Well for once here's a game which actually uses the proper

DOUBLE YING ROUND 01 - GROUP 01	
AUSTRIA	ALGERIA
1. BRUCE MUEHNER	1. MOU TIA
2. JANE TREN	2. JOE JIM
3. PAUL TUN	3. PAUL JIM
4. POLI W	4. PAUL T
5. JIM WALTER	5. JIM W
6. JIM W	6. JIM W
7. JIM W	7. JIM W
8. JIM W	8. JIM W
9. JIM W	9. JIM W
10. JIM W	10. JIM W

What a riveting match! I'll certainly be glued to this one for the full ninety minutes, oh, Brian!

names of the England players. For example there's Lineker, Bull, Gascoigne and Shilton (and those are just the defenders).

What you do in the game has been described pretty accurately in many a review of management game, but let's have a brief recap, shall we?

You've got about fifteen bods in your squad. Obviously only eleven of them are going to be running out of the tunnel on the day, but what with injuries, strikes, drunkenness and people staying in their locker rooms and deciding not to play, you might need the back-up of the other four.

How to get yourself onto a football team.

- Get your parents to buy one, appoint your dad as manager and ask him to hire you for a huge fee.
- Call yourself Bryan Robson. You never need to actually play, then. You can just be injured the whole time.
- Become really fat, stick your tongue out a lot and speak in a Geordie accent.
- Turn up at a match dressed in one team's kit then, when no-one's looking, run on, smack a player (with the same kit on as you) and take his place.
- Train hard and get noticed by a scout. Then practise until you're good enough.

You also get the chance to train, select position and tactical patterns. As you're doing this, the weeks roll by and the qualifying matches start for the world cup.

But the greatest thing about *World Cup* is the graphics. You actually get a grandstand view of all the matches. You simply sit back and watch both the action on the screen and a commentary telling you which of the little characters is which.

World Cup looks like it could be the future of management sims. There's all the team training, morale and selection

stuff to go through, but there's also the nail-biting, nerve-chewing, hair-wrenching bit. You'll know exactly how those managers feels as they sit on the sidelines unable to do anything but shout loudly and occasionally pick their noses.

Watch out for the full review next issue.



The crowd is going wild here in Austria. He's on his feet, and he's, er, leaving by the back gate. Oh well, I'm excited by it.



THE YOUR SINCLAIR SUPERSTORE

NOW OPEN!

Got loads of loose change and crumpled-up £5 notes stuffed down your trouser pockets that you don't know what to do with? Then give it all to us! Here at the YS Superstore we've got a glittering selection of software 'accoutrements' just waiting to tickle your fancy. So don't delay - send us your dosh and lose weight the YS way! (You'll be so glad you did!)



The YS Tipshop Tiptionary

If it's big tips you want then look no further - the Tiptionary's fit to burst with them! And there are squillions of POKEs on the free cover tape tool (You'll wonder how you survived without it!)

Description	Price	Order No
YS Tipshop Tiptionary	£8.95	TIPS



The YS Binder

Your copies of YS won't stop thanking you once you've tucked them up safely in a set of slinky YS binders. Each can handle a year's worth of Spec-fun and, as a very special favour, we'll let you have 90p off the price of two!

Description	Price	Order No
YS Binder	£4.95	MY100
2 Binders	£9.00	MY102



3D Construction Kit

It's just like playing with Lego, only a little bit more complicated! Create whole universes with Domark's new Freescape gamesmaker!



Description	Price	Order No
3D cass	£18.99	MY139C
3D disk	£18.99	MY139D



Terminator 2

Arnie's back in town! And he's brought seven levels of fast, furious mayhem with him. Fight the evil T1000, avoid trucks, cars and helicopters and solve fiendish puzzles - all in glorious colour. You'll also have to look after young John Connor and his mum Sarah. But mainly you just give the T1000 a good kicking! It's ber-illiant!

Description	Price	Order No
Term 2 cass	£8.99	MY143C
Term 2 disk	£11.99	MY143D

PRICES INCLUDE



HOTLINE
0458 74011



POSTAGE, PACKING AND VAT NO HIDDEN EXTRAS



Smash TV

It's the game-show of the future and boy, is it addictive? It sure is! Dozens of rooms, loads of aliens and tons of power-ups and prizes make this wickedly fast game an absolute must to own!



Description	Price	Order No
Smash cass	£8.99	MY142C



Fun School 4

Fun School 4 is the latest in Europress' popular series of educational software. The clever designs and amusing characters really do make learning fun! PLEASE STATE THE AGE GROUP OF THE USER (UNDER 6, 6 TO 8, OVER 8) SO WE KNOW EXACTLY WHAT YOU'RE AFTER.

Description	Price	Order No
F School 4 cass	£7.99	MY144C
F School 4 disk	£9.99	MY144D



HOW TO ORDER

JUST MAKE A NOTE OF THE PRODUCT NAME AND ORDER NUMBER AND FILL IN THE ORDER FORM BELOW... OR RING OUR HOTLINE NUMBER ON 0458 74011

YOUR SINCLAIR SUPERSTORE

Mmm-mm. You're right, you know, I really do need the following YS goodies pretty darn bad!

Name

Address

Postcode

Phone number

Description	Price	Order No
TOTAL ORDER		

Method of payment (please circle) • Access • Visa • Cheque • PO

Credit Card No

Expiry date

Please make all cheques payable in pounds sterling to Future Publishing Limited, and send the whole lot off to YS Superstore, FREEPOST, The Old Barn, Somerton, Somerset TA11 7BR. And you don't even need a stamp!

NEXT MONTH



WHO WILL BE YOUR VALENTINE?

♥ Those lucky-in-love jugglers decide that there ain't no mountain high enough and there ain't no valley low enough to stop them bringing you the latest romantic reviews and meaningful Megapreviews.

♥ Make a note in your diaries it's a hot date, momma! All the regulars will be lined up outside the Odeon at eight o'clock. Who will you choose? Will it be lush and lustful Letters? Or how d'you fancy a soppy serenade with Spec-Tec? If both of those leave you completely cold, you could always go for an amble with amorous Adventures.



♥ Our covertape is dressed up to the nines. It's handbag's crammed full of POKEs, demos and amazing complete games. The whole caboodle is made even more entrancing with a squirt of eau d'amour.

♥ It's the most beloved machine in the world and we think it's about time that somebody stood up for it. Next month we're starting our SOS campaign - that's Save Our Speccy. If you feel that the Spec's getting a raw deal, then here's your chance to make your mark. Somewhere amongst all the lovely colour you'll find a letter that you can sign and send off to the appropriate peeps voicing your disgust and despair.

♥ Is your heart breaking? Do you have a problem that you just can't get off your chest? Is there nobody to listen? Well, nay fret cos we've got the perfect solution. She's called Linda and she can deal with anything. So start writing now and look out for a reply next issue. Yep, it's the new YS Problem Page. It's true, kids - everything we do, we do it for you.

Tear your heart out and sew it on your sleeve. The March issue of *Your Sinclair* will be on sale at your local love shop on Thursday the 6th of February, 1992.

5 GAME PACK

DIZZY'STM

EXCELLENT ADVENTURES

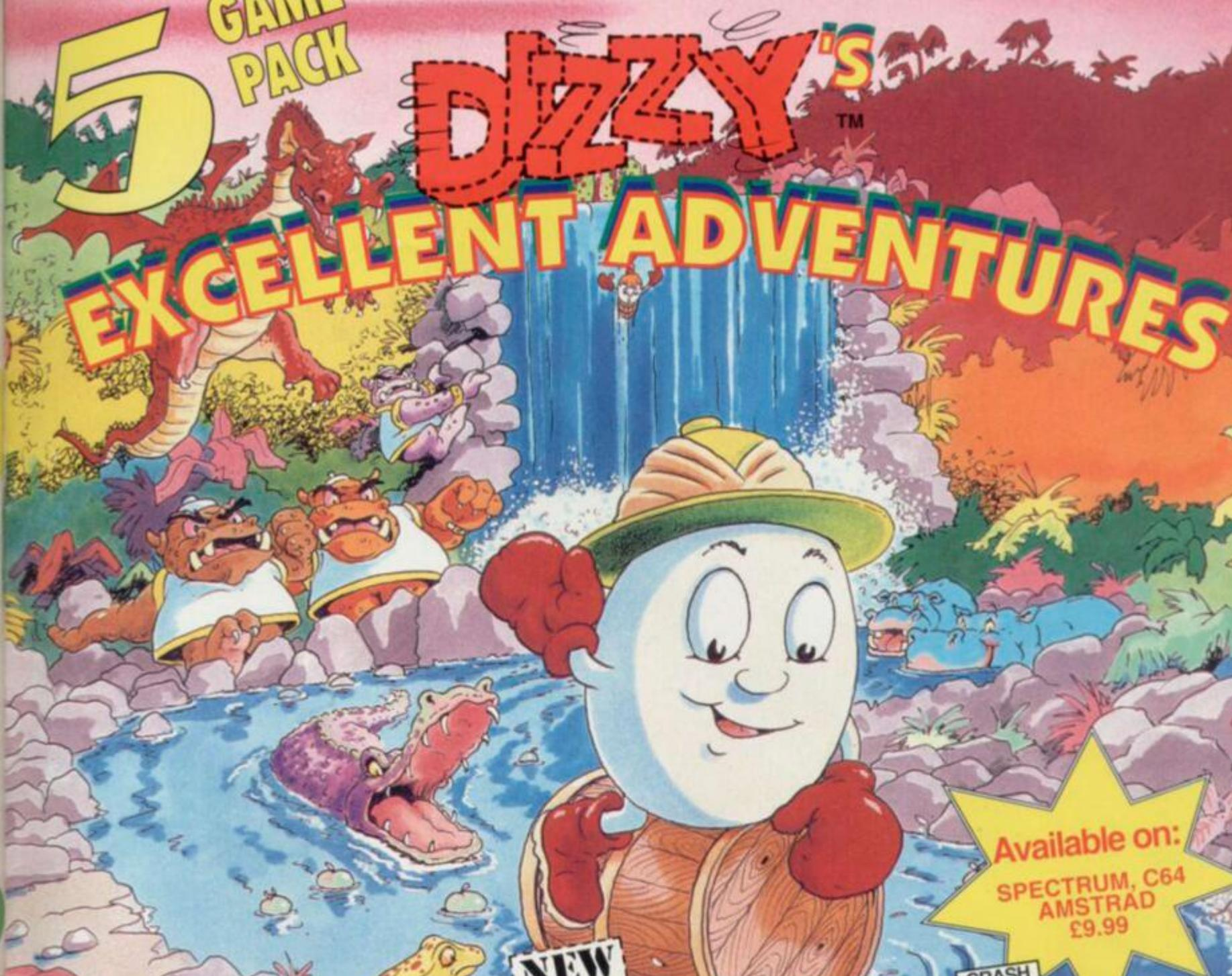

Available on:
SPECTRUM, C64
AMSTRAD
£9.99

NEW RELEASE

CRASH 92%



CRASH 80%

"A Crash Smash 80%"
Best budget - Sinclair User

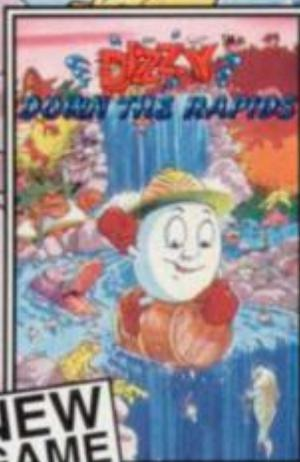

NEW GAME

Inspiringly Adventerous,
Splashing fun with a MEGA
Soundtrack

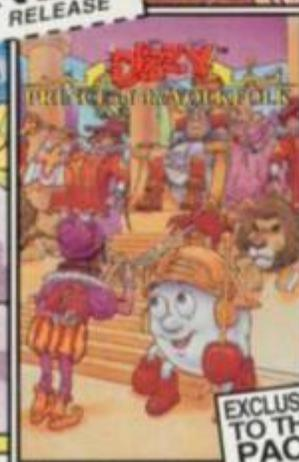

EXCLUSIVE TO THIS PACK

"Up to the usual high Dizzy
standards"
Amstrad Action



92% CRASH SMASH

NEW GAME

"It's damned BIG!"
Amstrad Action
"SHEER DIZZY HEAVEN!"
CRASH



92%CRASH]
"A smashing game!"
New Computer Express



CODEMASTERS

© Codemasters Software Company Limited 1991. PO Box 6, Leamington Spa, England, CV33 0SH

HELP LINES

NEW RELEASE INFO LINE 0898 555 000 (Tells you what is being released this month)

If you can't get any further in any of these games and would like us to give hints & tips on how to solve all the puzzles just phone the numbers below. Please don't phone unless you are really stuck and make sure you get permission from the person who pays the phone bill first! Calls costs 36p per minute during off peak time and 48p per minute at all other times. (GREAT BRITAIN ONLY)

ATARI ST AND AMIGA
TREASURE ISLAND DIZZY 0898 555 092
LITTLE PUFF 0898 555 095
ROCKSTAR 0898 555 090
FANTASY WORLD DIZZY 0898 555 078
SEYMOUR IN HOLLYWOOD 0898 555 010
SPIKE IN TRANSYLVANIA 0898 555 105

SPECTRUM, AMSTRAD, C64
DIZZY
TREASURE ISLAND DIZZY
FANTASY WORLD DIZZY
LITTLE PUFF
ROCKSTAR
MAGICALAND DIZZY
SLIGHTLY MAGIC
SEYMOUR IN HOLLYWOOD
SPIKE IN TRANSYLVANIA

0898 555 093
0898 555 091
0898 555 078
0898 555 094
0898 555 090
0898 555 096
0898 555 090
0898 555 010
0898 555 105

WF WRESTLEMANIA



WORLD WRESTLING FEDERATION

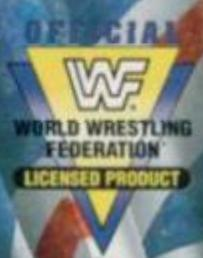

*Trademark of TitanSports, Inc. **Hulk Hogan, Hulkmania, and Hulkster are trademarks of Marvel Entertainment Group, Inc. Licensed exclusively to TitanSports, Inc. All other distinctive character names, likenesses and logos are trademarks of TitanSports, Inc. © 1991 All rights reserved.



ocean

**ATARI ST
AMIGA
IBM PC & COMPATIBLES**

**SPECTRUM
AMSTRAD
COMMODORE**