

Publication Office / 1780 Broadway, New York, New York 10019 / Telephone: JUdson 6 2640 / Cable Address: Cash Box, N. Y.

**GEORGE ALBERT**  
President and Publisher

**MARTY OSTROW**  
Vice President

**IRV LICHMAN**  
Editor in Chief

**EDITORIAL**

MARV GOODMAN

Assoc. Editor

ALLAN RINDE

West Coast Editor

JOHN KLEIN

ED KELLEHER

FRED HOLMAN

**EDITORIAL ASSISTANTS**

MIKE MARTUCCI

ANTHONY LANZETTA

**ADVERTISING**

BERNIE BLAKE

Director of Advertising

**ACCOUNT EXECUTIVES**

STAN SOIFER, New York

HARVEY GELLER, Hollywood

WOODY HARDING

Art Director

**COIN MACHINE & VENDING**

ED ADLUM

General Manager

CAMILLE COMPASIO, Chicago

LISSA MORROW, Hollywood

**CIRCULATION**

THERESA TORTOSA, Mgr.

**HOLLYWOOD**

HARVEY GELLER

6430 Sunset Blvd., Hollywood, Calif. 90028

Phone: (213) 465-2129

**NASHVILLE**

JUANITA JONES

806 16th Ave. South, Nashville, Tenn. 37203

Phone: (615) 244-2898

**CHICAGO**

CAMILLE COMPASIO

29 E. Madison St., Chicago, Ill. Phone: (312) FI 6-7272

**INTERNATIONAL DIRECTOR**

CARLO NISTRI

3 Cork Street, London W1 Tele 01-7342374

**ENGLAND**

DORRIS LAND

3 Cork Street

London W1

Tel. 01-7342374

**GERMANY**

CHRISTIAN TOERSLEFF

2 Hamburg 56

Leuchtturmeg 30

Tel: 34-91-94-86

**BRAZIL**

PEDRO FRAZAO

DE VASCONCELOS

Rua Frei Caneca, 11, Apt. 13

Sao Paulo, S.P., Brazil

Tel: 257 15 58

**ARGENTINA**

MIGUEL SMIRNOFF

Belgrano 3252, Piso 4 "B"

Buenos Aires, Argentina

Tel: 89-6796

**CANADA**

WALT GREALIS

RPM

1560 Bayview Ave.

Toronto 17, Ontario

Tel: (416) 89-2166

**FRANCE**

FRANC G. LIPSIC

32 Rue Du Moulin Joly

Paris XI

Tel. 023-90-06

**SPAIN**

JOAQUIN MERINO

Presidente Cormona, 11

Madrid 20, Spain

Tel. 270-2915

**ITALY**

BRUNO POZZA

5, Corso Europa

Milan

Tel: 704691

**HOLLAND**

PAUL ACKET

Theresiastraat 59-63

The Hague

Tel: 837700

**BELGIUM**

ETIENNE SMET

Hugo Verrieststraat 87

Sint-Niklaas (wass)

Tel: (03) 76.48.80

**AUSTRALIA**

PETER SMITH

40 Winters Way

Doncaster 3108

Victoria, Australia

**MEXICO**

SALVADOR ARREGUIN

ANTONIO SENS

Tiber 100 — 7 y 8 Pisos

Mexico 5, D.F.

Tel: 525-39-52 11-62-96

**JAPAN**

Adv. Mgr.

SHOICHI KUSANO

Editorial Mgr.

MORIHIRO NAGATA

466 Higfoshi-Olzumi

Neirimoku

Tokyo

*from the desk of . . .*

GEORGE ALBERT

OF



JUNE, 1970

Dear Friends:

As we have learned in recent years, each 12 months of music industry activity is a period of marked change and evolution. Obviously, the industry has attached particular significance to the past year, since it came on the eve of a new decade. And, fittingly, we enter the 1970's with innovations on the horizon, almost ready to be presented to the consumer. One of these, of course, is the development of the audio/visual cartridge for home use, a system that will add a new dimension to home entertainment utilizing TV sets presently in use. One of the challenges facing the industry -- and it should be met right now -- is how to employ effectively the creative talents that flow from an aural entertainment into a audio/visual package that will excite the recording fan. And, too, we must not forget the business of the music business -- the means, from record company to wholesaler to retailer, through which the consumer finally gets his hands on today's great entertainment buy, the disk or tape.

Cash Box Magazine, completing its 28th year as a trade publication dedicated to the healthy progress of the music industry, is entering the 1970's with its own program for growth to enhance its ability to accurately reflect the business on all levels. As the business evolves, so must we adapt to an industry that requires and demands greater sophistication and reliability of reporting.

We believe we will continue to be deserving of your support. The staff of Cash Box and I are ever grateful for your past support and kind words about Cash Box' own evolution.

George Albert

President and Publisher

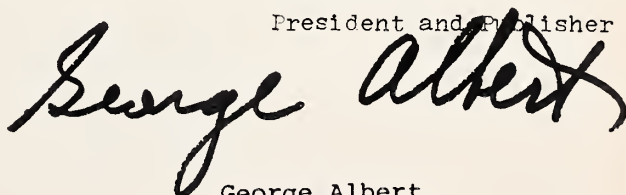

George Albert

President and Publisher

# INDEX OF DIRECTORY ADVERTISERS

## MUSIC DOMESTIC PART 1

<b>A</b>	Abkco Industries.....23-40	Godwin Dist.....102	<b>Q</b>	Queen City Albums.....16-
	Abrams, Bob.....168	Golden Records.....10		Queens Litho.....181
	A&I Dist.....66	Goldsboro, Bobby.....12	<b>R</b>	
	A&L Dist.....96	Greene, Charles Randolph.....60		Randolph, Boots.....250
	A&M Recording Studios.....189	Greene, Jack.....230		RCA Victor Records Gatefold, 119, 181, 193
	A&M Records.....79	Guess Who.....119		Record Merch. Co.....96
	Alco Research & Eng.....166	<b>H</b>		Request Records.....46
	Allen, Rex.....227	Hagers.....251		Revere, Paul & Raiders.....20
	All South Dist.....104	Happy Tiger Records.....153		Richmond Organization (TRO).....209
	All-State Dist (N.J.).....106	Harms, T.B. Co.....212		Richland, Tony.....172
	All Tapes.....144	Hassilev, Alex, Studios.....194		Rivers, Johnny.....165
	Alpha Dist.....81	Heider Recording, Wally.....190		Robbins Feist & Miller.....217
	Alshire Int'l.....56	Hit Factory.....188		Rondor Group, Publ.....218
	Amaret Records.....77	Howard, Jan.....233		Rosen, Herb.....170
	Ames, Ed.....137	<b>I</b>		Rosen, Raymond Dist.....94
	Ampex Corp.....65	IFA.....169		Ross, Diana.....125
	Anderson, Bill.....228	Inherit Prod.....133	<b>S</b>	
	Anka, Paul.....127	International Hotel.....15		Scene 70.....195
	Apple Records.....23, 40	<b>J</b>		Scepter Records.....43
	Association.....139	James, Sonny.....249		Schony's One-Stop.....72
	Atkins, Chet.....250	Jamie/Guyden.....158		Schwartz Bros. Dist.....100
	Audio Arts.....216	Janus Records.....159		Schultz, Albert.....176
		Jazz Spotlight.....154		Screen Gems/Columbia Music.....211
		Jones, Tom.....99		Seaboard Dist.....98
<b>B</b>		<b>K</b>		Seeiy, Jeannie.....239
	Bandana Ent.....73	Kapp Records.....177		SESAC.....222
	Bang Records.....67	Kent Modern.....202		Sinatra, Nancy.....93
	Barnaby Records.....155	Kim Records.....184		Sound City Studios.....201
	Basford, H.R. Co.....74, 94	King, B. B.....167		South Eastern One-Stop.....74
	Belafonte, Harry.....145	Kirshner Ent. Corp.....71		Southern Plastics.....160
	Bell Records.....62, 63	<b>L</b>		Southland Dist.....104
	Belwin Mills Music.....207	Le-Bo Products.....223		Speciality Records.....162
	Bendig (Fermata).....52	Lettermen.....89		SRB Corp.....134
	Bennett, Tony.....175	Liberty Records.....53		SSSI Records.....161
	Benton, Brook.....111	Litrov-Levinson.....170		Stan's Dist.....80
	Bestway Products.....162	London Records.....75, 83		Stan's One-Stop.....74
	Beta Dist.....90	Lopez, Trini.....183		*Star Title Strip.....64, 110
	Blood Sweat & Tears.....11	Lord, Bobby.....252		Stax-Volt Records.....55
	Blue Thumb Records.....59	Lomar One Stop.....64		Steadman One-Stop.....72
	Blues Image.....197	Lowery Music.....219		Steppenwolf.....109
	Borchetta, Mike.....172	Lynn, Loretta.....234		Stereo Sonic Studios.....201
	Bourne Music.....220	<b>M</b>		Stevens, Ray.....155
	Broadway Recording Studios.....199	Mack, Warner.....235		Stigwood Organization.....115
	Brown, James.....129	Magid, Lee.....78		Stone Flower Prod.....101
	Brown Paper Co.....174	Malverne Dist.....102		Stuart, Fred.....172
	Buddah Records.....13	Mancini, Henry.....181		Sue, Peggy.....241
		Marks, E.B. Co.....214		Sunbury/Dunbar Music.....210
		Martin, Dean.....157	<b>T</b>	
<b>C</b>		Martin, Jimmy.....237		Tape Merchandising Co.....148
	Campbell, Glen.....147	Martin & Snyder One-Stop.....72		Taylor Electric Co.....106
	Campus Dist.....98	Martoni Rest.....201		Three Dog Night.....109
	Capitol Custom.....191	Mathis Johnny.....149		Tone Dist.....84
	Cardinal Export.....176	Mayfair Recording Studios.....190		Town Hall One-Stop.....76
	Cartridge Control Corp.....150	MCA Recording Studios.....187		Transaction Music.....206
	Cassette Comm. Corp.....146	Melanie.....95		Tree Music.....221
	Certron Corp.....91	Melody Sales.....90		Twitty, Conway.....242
	Chapman Dist.....96	Merit (Det) Dist.....98	<b>U</b>	
	Chappell.....205	Met-Richmond Dist.....92		Ultra Sonic Studios.....196
	Chess Records.....69	Metromedia Records.....97		Uni Records.....135
	Chicago.....117	Millard Agency.....50		United (Chi) Dist.....84
	Chips Dist.....106	MGM Records.....198		Universal Dist.....90
	Chrysalis.....179	Mogull, Ivan.....214		Universal Tape City.....156
	Clancy Bros.....200	Monarch Pressing.....166	<b>V</b>	
	CMA.....173	MRC Music.....204		Vanguard Recording Studios.....200
	Cocker, Joe.....123	M S Dist.....88		Viewlex Inc.....151
	Colossus Records.....45	Music Clearance Co.....208		Vinton, Bobby.....143
	Columbia Records.....9	Musical Export.....176	<b>W</b>	
	Command Records.....51	Musicle Isle.....17		Wakefield Mfg.....166
	Commander Music.....204	Myles, Lee.....180		Warner Brothers Music.....19
	Cramer, Floyd.....250	<b>N</b>		Watanabe Records-Japan.....51
	Crewe Group.....131	Nashboro Records.....224		Warwick, Dionne.....107
		National Tape Dist.....85		Wayside Records.....248
<b>D</b>		Natural Sound Studios.....186		Webb, Jim.....132
	Davis, Jimmy.....229	Nesmith, Michael.....113		Wells, Kitty.....243
	Decca Recording Studios.....187	<b>O</b>		Wendy Dist.....92
	Decca Records.....203	One-Stop Service.....174		Wes Farrell Org.....19
	D&H Dist. Co.....100	Osborne Bros.....238		West Coast Music.....70
	Diamond, Neil.....121	Owens, Buck.....247		White, Edward R.....174
	Dome Dist.....86	<b>P</b>		Whitney Studios.....190
	Doors.....21	Paramount Records.....47		Who's Who In Show Business.....68, 69
	Dooto Records.....152	Peer Southern.....220		Wilburn, Bros.....245
	Dot Records.....253	Penny Farthing.....163		Williams, Andy.....105
	Duke/Peacock Records.....14	Pep Dist.....92		William Morris Agency.....171
		Peters Int'l.....178	<b>Z</b>	Win One-Stop.....76
<b>E</b>		*Philips Recording Studios.....164		
	Eltron Export.....176	Pickwick Int'l.....41		
	Epic Records.....61	Plastic Products.....166		
	Eskin, David, Export.....176	Polydor Records.....57		
		Presley, Elvis.....Cover IV		
<b>F</b>		Program One-Stop.....66		
	Faith, Percy.....201	Progressive Label.....148		
	Fame Studios.....185	Project 3.....103		
	Famous Music Corp.....215			
	F&F Dist.....94			
	Feliciano Jose.....193			
	Ferrante & Teicher.....192			
	Four Star Music.....210			
	Four Star T. V.....212			
	Futura-Tone Dist.....82			
<b>G</b>				
	Gallico, Al Music.....213			
	Garner, Errol.....41			
	Gate City One-Stop.....66			
	General Dist.....88			
	Gersh, Richard.....168			
	Gil Music.....212			

# The rock heard round the world.

Columbia Records is in the business of making records. But we believe that recordings alone aren't enough. Artists and audience belong together.

That's why Columbia Records and CBS International recently embarked on a two-day rock fest in London's prestigious Albert Hall, presenting five outstanding groups who had never before appeared in Europe.

A measure of the success of Columbia's venture is this comment from England's *Record Retailer*:

"The Sounds of the 70's concerts were highly successful. It's a venture that

could well be followed by other companies and serves to emphasize once more that CBS has one of the strongest contemporary catalogues in the industry."

And remarks like these from leading British music magazines about the Albert Hall performances:

"Winter, the albino Texas blues singer of amazing instrumental facility and a voice injected with raw power."

"Flock started brilliantly with 'Introduction,' a number from their album."

"Taj Mahal has a big reputation and his fans include Eric Clapton, Peter Frampton and Mick Jagger."

"Santana managed to excite a presumably heavy rock audience . . . a superb rhythm section."

•"Exciting arrangements, sharp profession-

alism and musicianship made It's A Beautiful Day a beautiful band."

But the Sounds of the 70's is only part. Columbia artists like Simon & Garfunkel, Janis Joplin, Chicago and Leonard Cohen have toured Europe to tumultuous audiences and press. For his first concert appearance in two years, Bob Dylan chose the Isle of Wight Festival. Blood, Sweat & Tears will appear at Albert Hall in July. And the list goes on.

No doubt, where Columbia leads, others will follow. But we're proud of that leadership. And we'll continue to use it to add to the excitement and development of contemporary music.



# Bobby Goldsboro

Current LP:

**BOBBY GOLDSBORO'S  
GREATEST HITS**

Management  
LENNY DITSON  
162 W. 56 St.  
New York, N.Y.



© 1970



# DIRECTORY INDEX

Album Jacket Manufacturers.....	180, 182
Custom Tape Duplicators.....	154, 156, 158
DJ Poll Results (Big 3 Pop Winners).....	16
DJ Poll Results (Big 3 Country Winners).....	246
DJ Poll Results (Country Music).....	252
DJ Poll Results (Past Winners).....	22, 41
DJ Poll Results (Pop).....	18, 20
Envelope & Mailers.....	174
Golden Albums.....	124, 126, 128
Machine Shops.....	166
Million Sellers.....	116-122
One-Stops.....	64-78
Printers & Lithographers.....	202, 203
Publishers Hitting Top 100.....	204-220
Rack Jobbers.....	108-114
Record Distributors.....	80-106
Record Importers & Exporters.....	176, 178
Record Manufacturers.....	42-60
Record Platers.....	182
Record Producers Hitting Top 100.....	132, 134, 136, 138
Record Pressers.....	160, 162, 164, 166
Record Promotion & Publicity Offices.....	168, 170, 172
Record Sleeve Manufacturers.....	178
Record Mailers.....	174
Recording Studios.....	184-201
SESAC Publishers.....	222, 223, 224, 254
Tape Distributors.....	144-152
Trade Associations.....	178

# INTERNATIONAL INDEX

Argentina.....	64
Australia.....	94
Belgium.....	95
Brazil.....	82
Canada.....	90
France.....	73
Germany.....	32
Great Britain.....	4
Holland.....	78
Italy.....	42
Japan.....	50
Mexico.....	96
Spain.....	87



Exclusively Represented By  
**LARRY GOLDBLATT**  
BLOOD, SWEAT AND TEARS, LTD.  
120 East 56th Street  
New York, New York 10027  
(212) 355-6154

Columbia Records

# BLOOD, SWEAT & TEARS

82  
58  
16  
16  
2  
1  
0  
4

# PEACOCK RECORDS,

INC

# DUKE RECORDS,

INC

2809 Erastus Street/Houston, Texas 77026  
A/C 713 673-1225 • 673-2611

SUBSIDIARIES

BACKBEAT/SONGBIRD/SURESHOT

## Duke Peacock Record Family

**Bobby Bland**  
**Carl Carlton**  
**Eddie Wilson**  
**Ernie K-Doe**  
**O.V. Wright**  
**Oscar Perry**  
**Jeanette Williams**  
**Paulette Parker**  
**John Roberts**  
**The Lamp Sisters**  
**The Malibus**  
**Buddy Lamp**  
**The Soul Twins**  
**"Sunshine"**  
**The Insights**  
**Barry Jones**

AND MANY, MANY OTHERS

## Going Strong Now

**Bobby Bland**  
**"IF LOVE RULED THE WORLD"**  
**Carl Carlton**  
**"DROP BY MY PLACE"**  
**The Insights**  
**"LOVE AND PEACE OF MIND"**  
**Oscar Perry**  
**"FOOL FROM THE STICKS"**

WATCH

**DUKE & PEACOCK**

FOR BETTER AND BETTER RECORDS

# MUSIC INT'L PART 2

## A

Aberbach Music-Germany.....	35
Aberbach Music-Japan.....	62
Accord, Edition.....	
Ambassador Music-England.....	25
Anderle, Oscar-Argentina.....	66
Ansa Music-Argentina.....	66
Apollo-Italy.....	88
Apollon-Japan.....	56
Ardmore-England.....	17
Ariola-Eurodisc-Germany.....	37
Ariola-Holland.....	81
Artia Records.....	22
Atlantic Records.....	27

## B

Balcom Mfg.-Japan.....	54
Barbarella-Spain.....	87
Barclay-France.....	75
Beechwood-England.....	17
Big Chief-Canada.....	90
Bourne-England.....	25
Bovema-Holland.....	81
Boyd, Franklin, Ltd.....	10
Burlington-Palace-England.....	4

## C

CBS-Argentina.....	67
CBS-Canada.....	91
CBS-England.....	20
CBS-International.....	2, 3
CBS-Italy.....	47
CGD-Italy.....	48
Cam-Japan.....	52
Capitol Records.....	89
Carlin Music-England.....	24
Chantecler-Brazil.....	83
CNR-Holland.....	78
Columbia-Canada.....	91
Columbia-Japan.....	55
Continental, Discos-Brazil.....	85
Cornet Music, Germany.....	38
Corporacion Latino Americano	
Del Disco.....	86
Cromer Music.....	25
Crown Music-Japan.....	60
Curci-Italy.....	44

## D

Decca-England.....	13
Decca Records-USA.....	5, 6, 7, 8
Deutsche Grammophon	
Gesellschaft.....	32, 33, 34
Disc Jockey-Argentina.....	72
Discodis-France.....	73
Dot Records.....	40, 41

## E

Eastern Music-Japan.....	54
Eastern Sun-Japan.....	56
Edizioni Musicali-Italy.....	49
EMI-Argentina.....	68
EMI-England.....	11
EMI-Holland.....	81
Evolution-England.....	12

## F

Famous Music.....	40, 41
Fantasia-France.....	74
Feldman, B.....	21
Fermata-Argentina.....	64
Fermata-Brazil.....	84
Forsite-Canada.....	90
Francis Day & Hunter-England.....	21
Francis Day & Hunter-Germany.....	53

## G

Gamma-Mexico.....	96
Global Music-Germany.....	39
Gravacoes Electricas-Brazil.....	85

## H

Hansa Schallplatten-Germany.....	95
Hara Music-Japan.....	63

## I

Industrial Commercial Plastics.....	22
Ishihara Music-Japan.....	61
Ishii-Japan.....	63

## J

James, Dick, Music Ltd.-England.....	15
Japan C.A.M.....	52
Jobete Music.....	30, 31
Jun & Kei-Japan.....	60

## K

Keith Prowse-England.....	
King Records-Japan.....	53
Korduletsch-Germany.....	95

## L

La Compagnie, Editions-France.....	77
------------------------------------	----

## M

MCA Inc.....	5, 6, 7, 8
Major Minor-England.....	16
Martin-Coulter Enterprises.....	18
Maurice, Peter-England.....	17
Mecca-Japan.....	62
Meisel Group-Germany.....	95
Mellin, Robt.-England.....	10
Mellograf-Argentina.....	72
Mews Music-England.....	18
Microfon-Argentina.....	70
Motown Records.....	28, 29
Music Hall-Argentina.....	70

## N

Negram-Holland.....	80
New Orient Music-Japan.....	63
Nichion-Japan.....	58
Nippon Columbia.....	55
Nippon Crown-Japan.....	60
Nor-Brand-Canada.....	90

## O

Odeon-Argentina.....	68
Ongaku-No-Tomo Sha-Japan.....	50
Orlake, Ltd.-England.....	25
Ortega, Palito.....	69

## P

Page One Ltd.....	15
Paramount Int'l.....	40, 41
Peer-Southern-England.....	23
Philips Int'l.....	79
Phonogram-Argentina.....	71
Phonogram-Australia.....	94
Phonogram-Italy.....	46
Polydor Records.....	34

## Q

Quality Records-Canada.....	93
-----------------------------	----

## R

RCA-Argentina.....	65
Relay Music-Argentina.....	65
Rhythm Music.....	63
Ricordi-Italy.....	43
Ri-Fi-Italy.....	45
Robbins-England.....	21

## S

Seven Seas Music.....	53
Shinko Music-Japan.....	61
S.I.C.A.M.-Brazil.....	82
Slezak, Rudolf-Germany.....	36
Southern Music-England.....	23
Sparta Music-England.....	22
Steed Records.....	40, 41
Stockholms Musikproduktion-	
Sweden.....	86
Suisei-Sha-Japan.....	50
Sugar Music-Italy.....	42
Sunbury-England.....	9
Supraphon-England.....	22

## T

Tamla-Motown.....	28, 29
Teichiku Records.....	58
Tizoc-Mexico.....	Facing Int'l. Cover
Toho-Japan.....	52
Tokyo Music.....	62
Toshiba Records-Japan.....	59
Track Records-England.....	14

## V

Victor Company-Japan.....	57
---------------------------	----

## W

Warner Brothers Music.....	19
Watanabe Records-Japan.....	51

## Z

Zen-On Music-Japan.....	62
-------------------------	----

WE CAN MAKE IT TOGETHER IF WE TRY!



THE BUDDAH FAMILY OF LABELS :



# COIN MACHINE INDEX PART 3

A	E	M	S
Ace Holdings Ltd. ....9	Eastern Novelty Co. ....16	Marvel Mfg. Co. ....52	Seeburg Sales Corp. ....27
Active Amuse. Co. ....58	Empire Int'l. ....4, 18	Midway Mfg. Co. ....36, 37	Sega Enterprises ....10, 11
Advance Automatic Sales, Co. ....56		Mondial Commercial Corp. ....12	Shaffer Dist. Co. ....59
Allied Leisure, Ind. ....49	<b>F</b>	Irving Morris Co. ....61	Spindel Insurance Co. ....50, 62
All-Tech Ind., Inc. ....19	Fischer Mfg. Co., Inc. ....13	MONY.....62	Standard-Harvard Metaltypers.....61
American Shuffleboard.....17	J.F. Frantz Mfg. ....51	Murrey & Sons, Inc. ....33	Struve Dist. Co. ....18
Associated Coin Amuse., Co. ....Cov. 3			Myron Sugerman Int'l. ....3
Atlas Music Co. (Chi.).....50	<b>G</b>		
Atlas Dist. (Pitt.).....61	General Vending Co. ....16		
	Greco Bros. ....5	<b>N</b>	
<b>B</b>		Nutting Associates .....48	<b>T</b>
Bally Distributing .....58		Nutting Industries.....54	Taito Trading Co. Ltd. ....8
Bally Mfg. Corp. ....36, 37	<b>H</b>	NYSCMA.....52	Trimount Automatic Sales.....18
Banner Specialty Co. ....58	Hastings Dist. Co. ....52		
R.H. Belam Co. ....14	H.Z. Vending Co. ....58		
Bilotta Enterprises.....53		<b>P</b>	
BRAD, Inc. ....51	<b>I</b>	Portale Automatic.....50	<b>U</b>
Brunswick Copr. ....47	I.C.M.O.A. ....62	P.Z.P. Mfg. ....51	U.S. Billiards Co. ....39, 52
	Int'l. Mutoscope.....20		United Billiards Inc. ....31, 43
<b>C</b>	<b>K</b>		Urban Industries.....51
Chicago Coin Machine .....57	Irving Kaye Co. ....45	<b>R</b>	
Circle Int'l. ....55		Rene Pierre.....8	<b>V</b>
Cleveland Coin Int'l. ....6	<b>L</b>	C.A. Robinson Dist. ....4	Valley Mfg. & Sales Co. ....15
Crosse-Dunham.....58	London Coin Mach., Ltd. ....5	Rock-Ola Mfg. Co. ....23	
		Rowe International.....25	<b>W</b>
<b>D</b>		Royal Dist. Corp. ....60	Westchester Op's Guild .....51
Davis Distributing .....59		Runyon Sales Co. ....58	WLCO Corp. ....52
			William's Electronics Inc. ....7
			World Wide Dist. ....56
			Wurlitzer Company.....29

# GO GOLDEN!

## GOLDEN RECORDS

The sound of children...an international language

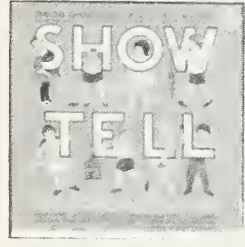

Show and Tell

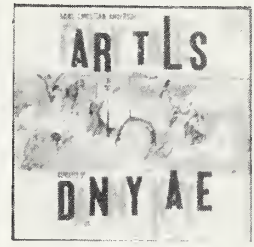

Hans Christian Andersen's Fairy Tales — Danny Kaye



Romper Room



The Wonderful Wizard of Oz

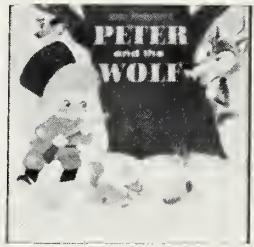

Peter and the Wolf



The Horse In The Striped Pajamas — Captain Kangaroo

## GOLDEN RECORDS

goes into the sound of pop...with 2 new labels!



GOLDEN RECORDS a division of A.A. Records, Inc. 250 West 57 Street, New York, N.Y. 10019



# THE INTERNATIONAL BRINGS THE WORLD TO LAS VEGAS!



**more than you dreamed possible in one great resort complex!**

Never anything like it before! At the International you enjoy the very greatest names in entertainment . . . sleep in gorgeous rooms reminiscent of Rome, Madrid or Paris . . . dine excitingly in any one of five colorful restaurants from Japan, Bavaria, Italy, Mexico or France . . . play outdoors on a magnificent 8½ acre park on rooftop . . . swimming, tennis, all the sun-drenched sports, plus a championship 18-hole golf course . . . spend a thrilling evening at a "Broadway" show in Las Vegas' first legitimate theatre . . . or even bring the youngsters for a fun-vacation of their own in the International's unique "youth hotel."

Write or phone for a colorful, fact-packed brochure.

  
**INTERNATIONAL**  
HOTEL • LAS VEGAS



# The Big Three

## Most Programmed Record

- 1 SUGAR SUGAR — Archies — Kirshner
- 2 BRIDGE OVER TROUBLED WATER — Simon & Garfunkel — Columbia
- 3 AQUARIUS & LET SUNSHINE IN — 5th Dimension — Soul City

## Most Programmed Album

- 1 ABBEY ROAD — Beatles — Apple
- 2 BRIDGE OVER TROUBLED WATER — Simon & Garfunkel — Columbia
- 3 LED ZEPPELIN — Led Zeppelin — Atlantic

## Most Programmed Male Vocalist

- TIE: 1 TOM JONES — Parrot
- 1 ELVIS PRESLEY — RCA
  - 2 GLEN CAMPBELL — Capitol
  - 3 NEIL DIAMOND — Uni

## Most Promising Up & Coming Male Vocalist

- 1 JOE COCKER — A&M
- 2 BOBBY SHERMAN — Metromedia
- 3 MARK LINDSAY — Columbia

## Most Programmed Female Vocalist

- 1 DIONNE WARWICK — Scepter
- 2 ARETHA FRANKLIN — Atlantic
- 3 DUSTY SPRINGFIELD — Atlantic

## Most Promising Up & Coming Female Vocalist

- 1 MELANIE — Buddah
- 2 BOBBI MARTIN — United Artists
- 3 DIANA ROSS — Motown

## Most Programmed Vocal Groups

- 1 BEATLES — Apple
- 2 CREEDENCE CLEARWATER — Fantasy
- 3 FIFTH DIMENSION — Bell/Soul City

## Most Promising Up & Coming Vocal Groups

- TIE: 1 JACKSON FIVE — Motown
- 1 CHICAGO — Columbia
  - 2 CROSBY, STILLS, NASH & YOUNG — Atlantic
  - 3 IDES OF MARCH — Warner Bros.

## Most Programmed Orchestras

- 1 HENRY MANCINI — RCA
- 2 HERB ALPERT — A&M
- 3 PERCY FAITH — Columbia

## Most Promising Up & Coming Orchestras

- 1 VINCENT BELL — Decca
- 2 DANNY DAVIS NASHVILLE BRASS — RCA
- 3 CHAS. RANDOLPH GREAN SOUNDE — Ranwood

## Most Programmed Instrumentalists

- 1 FERRANTE & TEICHER — United Artists
- 2 BOOKER T & MG's — Stax
- 3 VENTURES — Liberty

## Most Promising Up & Coming Instrumentalist

- 1 EL CHICANO — Kapp
- 2 VINCENT BELL — Decca
- 3 ELECTRIC INDIAN — United Artists



**INDEPENDENT DISTRIBUTOR**  
Roberts Record Distributing Company  
1815 Locust, St. Louis, Missouri 63103  
314/621-7171 Norm Hausfater / Glen Bruder

**INDEPENDENT DISTRIBUTOR**  
Eric-Mainland Distributing Company, 645 Bryant Street  
San Francisco, California 94107  
415/989-6286 Bill Wieland

**INDEPENDENT DISTRIBUTOR**  
Record Sales Corporation, 3000 Fleetbrook Drive  
Memphis, Tennessee 38116  
901 332-3650 Bill Biggs / Stan Daniels

**INDEPENDENT DISTRIBUTOR**  
M. S. Distributing Company, 7901 N Caldwell  
(Chicago) Morton Grove, Illinois 60053  
312/478-1133 312/966-0150 Vic Faraci / Ralph Kick

**ST. LOUIS BRANCH**  
1815 Locust, St. Louis, Missouri 63103  
314/621-7171

**SAN FRANCISCO BRANCH**  
1461 Park Avenue, Emeryville, California 94608  
415/654-0773

**NEW ORLEANS BRANCH**  
757 Central Avenue, New Orleans, Louisiana 70121  
504/833-3735

**NASHVILLE BRANCH**  
435-37th Avenue North, Nashville, Tennessee 37209  
615/269-5617

**MEMPHIS BRANCH**  
3000 Fleetbrook Drive Memphis, Tennessee 38116  
901/332-3650

**KANSAS CITY BRANCH**  
1800 Truman Road, Kansas City, Missouri 64127  
816 221-6965

**CHICAGO BRANCH**  
7901 N Caldwell, Morton Grove, Illinois 60053  
312 478-1133 312/966-0150

**MUSICAL ISLE OF AMERICA...  
TOTALLY SERVICING  
THE RECORDING  
INDUSTRY NATIONALLY**

# CASH BOX 1970 DISC JOCKEY POLL

## MOST PROGRAMMED POP SINGLES

- 1 SUGAR SUGAR — Archies — Kirshner
- 2 BRIDGE OVER TROUBLED WATER  
Simon & Garfunkel — Columbia
- 3 AQUARIUS & LET THE SUNSHINE IN  
5th Dimension — Soul City
- 4 Let It Be — Beatles — Apple
- 5 Raindrops Keep Falling On My Head — B.J. Thomas — Scepter
- 6 Come Together — Beatles — Apple
- 7 I Want You Back — Jackson 5 — Motown
- 8 Something — Beatles — Apple
- 9 Leaving On A Jet Plane — Peter, Paul & Mary — Warner Bros.
- 10 Spinning Wheel — Blood, Sweat & Tears — Columbia
- 11 Hey Jude — Beatles — Apple
- 12 Venus — Shocking Blue — Colossus
- 13 A Boy Named Sue — Johnny Cash — Columbia
- 14 Love Grows — Edison Lighthouse — Bell
- 15 ABC — Jackson 5 — Motown
- 16 Suite Judy Blue Eyes — Crosby, Stills & Nash — Atlantic
- 17 Spirit In The Sky — Norman Greenbaum — Reprise
- 18 Honkey Tonk Women — Rolling Stones — London
- 19 And When I Die — Blood, Sweat & Tears — Columbia
- 20 In The Year 2525 — Zager & Evans — RCA

## MOST PROGRAMMED POP ALBUMS

- 1 ABBEY ROAD — Beatles — Apple
- 2 BRIDGE OVER TROUBLED WATER — Simon & Garfunkel — Columbia
- 3 LED ZEPPELIN — Led Zeppelin — Atlantic
- 4 Blood, Sweat & Tears — Columbia
- 5 Crosby, Stills & Nash — Atlantic
- 6 Deja Vu — Crosby, Stills, Nash & Young — Atlantic
- 7 Chicago — Columbia
- 8 McCartney — Paul McCartney — Apple
- 9 Hey Jude — Beatles — Apple
- 10 Willie & The Poor Boys — Creedence Clearwater Revival — Fantasy
- 11 Santana — Columbia
- 12 This Is Tom Jones — Parrot
- 13 American Woman — Guess Who — RCA
- 14 Tommy — Who — Decca
- 15 In A Gadda Da Vida — Iron Butterfly — Atlantic
- 16 The Beatles — Double Pack — Apple
- 17 Age of Aquarius — 5th Dimension — Soul City
- 18 Herb Alpert & TJB Greatest Hits — A&M
- 19 Johnny Cash in Folsom Prison — Columbia
- 20 Elvis In Vegas — Elvis Presley — RCA

## MOST PROGRAMMED MALE VOCALISTS

- 1 TIE: TOM JONES — Parrot  
ELVIS PRESLEY — RCA
- 2 GLEN CAMPBELL — Capitol
- 3 NEIL DIAMOND — Uni
- 4 B.J. Thomas — Scepter
- 5 Bobby Sherman — Metromedia
- 6 Frank Sinatra — Reprise
- 7 Johnny Cash — Columbia
- 8 Joe Cocker — A&M
- 9 Bob Dylan — Columbia
- 10 Andy Williams — Columbia
- 11 Oliver — Crewe
- 12 James Brown — King
- 13 Tony Bennett — Columbia
- 14 Engelbert Humperdinck — Parrot
- 15 Nilsson — RCA
- 16 Stevie Wonder — Gordy
- 17 Marvin Gaye — Tamla
- 18 Donovan — Epic
- 19 Dean Martin — Reprise
- 20 Jack Jones — RCA

## MOST PROGRAMMED FEMALE VOCALISTS

- 1 DIONNE WARWICK — Scepter
- 2 ARETHA FRANKLIN — Atlantic
- 3 DUSTY SPRINGFIELD — Atlantic
- 4 Jackie DeShannon — Imperial
- 5 Peggy Lee — Capitol
- 6 Lulu — Atco
- 7 Bobbie Gentry — Capitol
- 8 Janis Joplin — Columbia
- 9 Diana Ross — Motown
- 10 Mama Cass — Dunhill
- 11 Joni Mitchell — Reprise
- 12 Judy Collins — Elektra
- 13 Eydie Gorme — RCA
- 14 Nancy Wilson — Capitol
- 15 Bobbi Martin — United Artists
- 16 Pet Clark — Warner Bros.
- 17 Mary Hopkin — Apple
- 18 Vikki Carr — Liberty
- 19 Laura Nyro — Columbia
- 20 Barbra Streisand — Columbia

## MOST PROGRAMMED VOCAL GROUPS

- 1 BEATLES — Apple
- 2 CREEDENCE CLEARWATER — Fantasy
- 3 FIFTH DIMENSION — Bell/Soul City
- 4 Blood, Sweat & Tears — Columbia
- 5 Lettermen — Capitol
- 6 Crosby, Stills, Nash & Young — Atlantic
- 7 Three Dog Night — Dunhill
- 8 Simon & Garfunkel — Columbia
- 9 Guess Who — RCA
- 10 Supremes — Motown
- 11 Sly & Family Stone — Epic
- 12 Ray Conniff Singers — Columbia
- 13 Rolling Stones — London
- 14 Sergio Mendes & Brasil '66 — A&M
- 15 Temptations — Gordy
- 16 Tommy James & Shondells — Roulette
- 17 Steppenwolf — Dunhill
- 18 Led Zeppelin — Atlantic
- 19 Friends of Distinction — RCA
- 20 Anita Kerr Singers — Reprise

## MOST PROGRAMMED ORCHESTRAS

- 1 HENRY MANCINI — RCA
- 2 HERB ALPERT — A&M
- 3 PERCY FAITH — Columbia
- 4 Paul Mauriat — Mercury
- 5 Ray Conniff — Columbia
- 6 Burt Bacharach — A&M
- 7 Vincent Bell — Decca
- 8 Bert Kaempfert — Decca
- 9 Chas. Randolph Grean Sounde — Ranwood
- 10 Hugo Montenegro — GWP
- 11 ANDRE KOSTELANETZ — Columbia
- 12 Billy Vaughn — Dot
- 13 Enoch Light — Project 3
- 14 Danny Davis' Nashville Brass — RCA

## MOST PROGRAMMED INSTRUMENTALISTS

- 1 FERRANTE & TEICHER U.A.
- 2 BOOKER T & MG's — Stax
- 3 VENTURES — Liberty
- 4 Chet Atkins — RCA
- 5 Santana — Columbia
- 6 Charlie Byrd — Columbia
- 7 Al Hirt — GWP
- 8 Floyd Cramer — RCA
- 9 Al DeLory — Capitol
- 10 John Barry — Columbia
- 11 Herbie Mann — Atlantic
- 12 Young Holt Ltd. — Brunswick
- 13 Mason Williams — Warner Bros.
- 14 Ramsey Lewis — Cadet
- 15 Peter Nero — Columbia
- 16 Buddy Rich — World Pacific
- 17 Hugh Masakela — Uni
- 18 Wes Montgomery — A&M
- 19 El Chicano — Kapp

(Con't. on next Page)

*The*  
*wes farrell*  
**ORGANIZATION**

3 EAST 54th STREET  
NEW YORK, N.Y., 10022

Telephone (212) 935-9140

POCKET FULL OF TUNES. BMI • CORAL ROCK PRODUCTIONS, INC.  
EVERY LITTLE TUNE. ASCAP • ANVIL PRODUCTIONS, INC.

***A TOTAL CREATIVE ENVIRONMENT***

# CASH BOX 1970 DISC JOCKEY POLL

## MOST PROMISING VOCAL GROUPS

- 1 TIE: JACKSON FIVE — Motown
- 1 CHICAGO — Columbia
- 2 CROSBY, STILLS, NASH & YOUNG — Atlantic
- 3 IDES OF MARCH — Warner Bros.
- 4 Vanity Fare — Page One
- 5 Friends of Distinction — RCA
- 6 Shocking Blue — Colossus
- 7 Guess Who — RCA
- 8 Three Dog Night — Dunhill
- 9 Chairmen Of The Board — Invictus
- 10 Edison Lighthouse — Bell
- 11 Marmalade — London
- 12 Carpenters — A&M
- 13 Badfinger — Apple
- 14 Tee Set — Colossus
- 15 Jaggerz — Kama Sutra
- 16 Country Coalition — Bluesway
- 17 Santana — Columbia
- 18 Mountain — Windfall
- 19 Delaney & Bonnie — Atlantic
- 20 Original Caste — TA
- 21 Country Store — TA

## MOST PROMISING ORCHESTRAS

- 1 VINCENT BELL — Decca
- 2 DANNY DAVIS NASHVILLE BRASS — RCA
- 3 CHAS. RANDOLPH GREEN SOUNDE — Ranwood
- 4 John Barry — Columbia
- 5 El Chicano — Kapp
- 6 Mystic Moods — Mercury
- 7 Pat Williams — Verve

## MOST PROMISING MALE VOCALISTS

- 1 JOE COCKER — A&M
- 2 BOBBY SHERMAN — Metromedia
- 3 MARK LINDSAY — Columbia
- 4 Ojiver — Crewe
- 5 R.B. Greaves — Atco
- 6 Eddie Holman — ABC
- 7 B.J. Thomas — Scepter
- 8 Mac Davis — Columbia
- 9 Norman Greenbaum — Reprise
- 10 Nilsson — RCA
- 11 James Taylor — Warner Bros.
- 12 John Denver — RCA
- 13 Tyrone Davis — Dakar
- 14 Van Morrison — Reprise
- 15 Leon Russell — Shelter
- 16 Michael Parks — MGM
- 17 Gordon Lightfoot — Warner Bros.
- 18 John Phillips — Dunhill
- 19 Neil Young — Reprise
- 20 Jerry Fuller — Columbia

## MOST PROMISING FEMALE VOCALISTS

- 1 MELANIE — Buddah
- 2 BOBBI MARTIN — United Artists
- 3 DIANA ROSS — Motown
- 4 Lulu — Atco
- 5 Joni Mitchell — Reprise
- 6 Evie Sands — A&M
- 7 Freda Payne — Invictus
- 8 Mary Hopkin — Apple
- 9 Laura Nyro — Columbia
- 10 Candi Staton — Fame
- 11 Linda Ronstadt — Capitol
- 12 Thelma Houston — Dunhill
- 13 Little Sister — Stoneflower
- 14 Gayle McCormick of Smith — Dunhill
- 15 Carolyn Franklin — RCA
- 16 Lydia Pense of Cold Blood — San Francisco
- 17 Peggy Lipton — Ode
- 18 Melba Moore — Mercury



### Agency

CMA  
8899 BEVERLY BLVD.  
LOS ANGELES, CALIF. 90048  
(213) 278-8899

### Commercials

CHARLES STERN  
9220 SUNSET BLVD.  
L. A. CALIF. 90069  
(213) 273-6890

### Management

TAM ENTERPRISES  
9121 SUNSET BLVD.  
SUITE 211  
LOS ANGELES, CALIF. 90069  
(213) 274-7278

# Paul Revere and the Raiders

E PLURIBUS MARK LINDSAY

RPB

CENTRAL  
ALASKA  
MA 8-1148

300

Old Time

COCKTAILS

HARD ROCK CAFE  
SPORTS  
BAR TV

HARD ROCK CAFE  
COCKTAILS

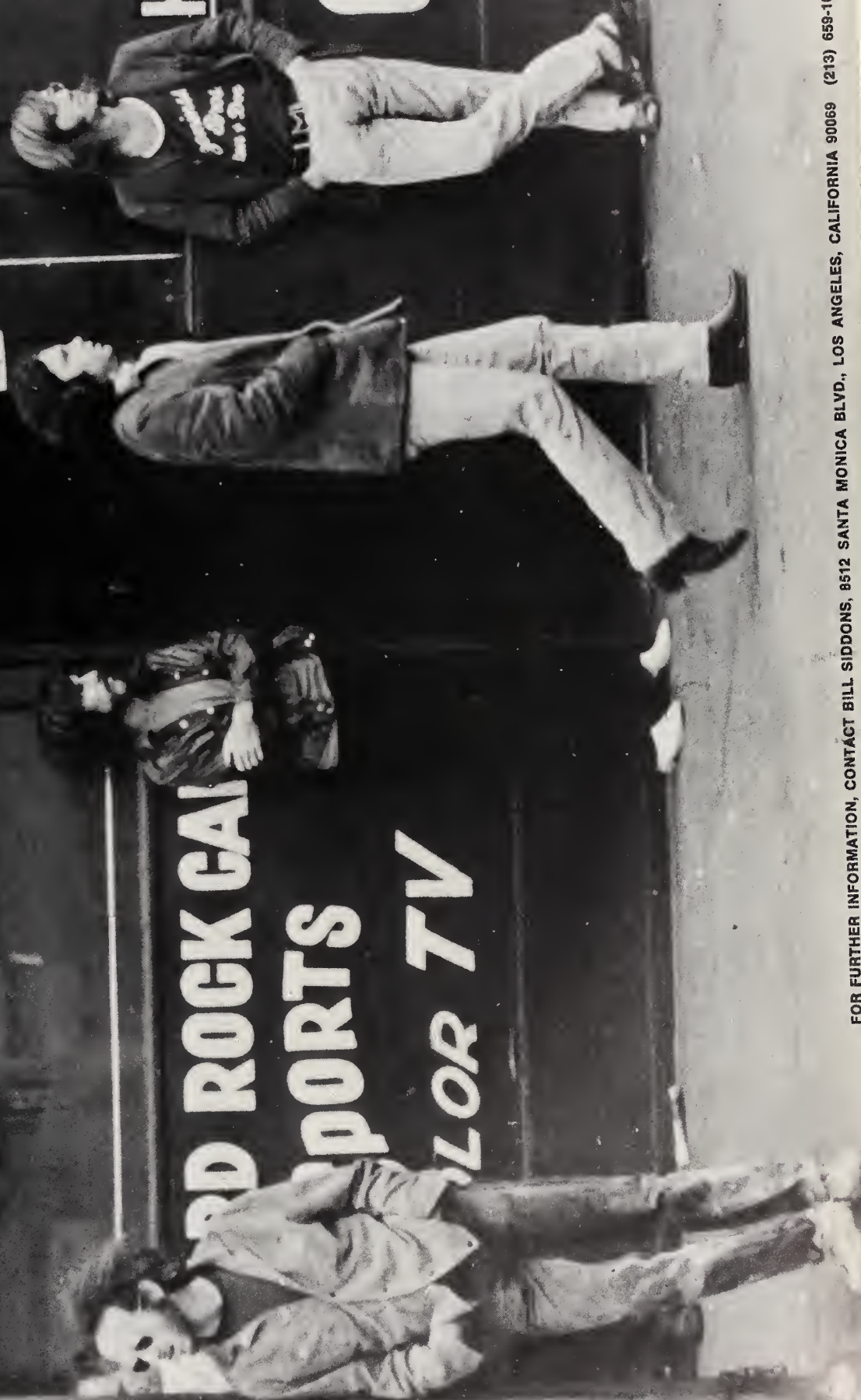

FOR FURTHER INFORMATION, CONTACT BILL SIDONS, 8512 SANTA MONICA BLVD., LOS ANGELES, CALIFORNIA 90069 (213) 659-1667

THE DOORS EXCLUSIVELY ON

# PAST WINNERS OF CASHBOX DJ POLLS

## MOST PROGRAMMED RECORD

- 1953—Till I Waltz Again With You—Teresa Brewer—Coral  
 1954—Secret Love—Doris Day—Columbia  
 1955—Melody Of Love—Billy Vaughn—Dot  
 1956—Sixteen Tons—Tennessee Ernie Ford—Capitol  
 1957—Don't Be Cruel—Elvis Presley—RCA Victor  
 1958—All The Way—Frank Sinatra—Capitol  
 1959—Tom Dooley—Kingston Trio—Capitol  
 1960—Mack The Knife—Bobby Darin—Atco  
 1961—Exodus—Ferrante & Teicher—United Artists  
 1962—Moon River—Henry Mancini—RCA Victor  
 1963—I Left My Heart In San Francisco—Tony Bennett—Columbia  
 1964—I Want To Hold Your Hand—Beatles—Capitol  
 1965—Downtown—Petula Clark—Warner Bros.  
 1966—Satisfaction—Rolling Stones—London  
     Ballad Of The Green Berets—Barry Sadler—RCA Victor (Tie)  
 1967—I'm A Believer—Monkees—Colgems  
     Strangers In The Night—Frank Sinatra (Tie)  
 1968—Love Is Blue—Paul Mauriat—Philips  
 1969—Hey Jude—The Beatles—Apple  
 1970—Sugar, Sugar—Archie—Kirshner

## MOST PROGRAMMED ALBUM

- 1956—Wee Small Hours—Frank Sinatra—Capitol  
 1957—Songs For Swinging Lovers—Frank Sinatra—Capitol  
 1958—Come Fly With Me—Frank Sinatra—Capitol  
 1959—Come Dance With Me—Frank Sinatra—Capitol  
 1960—Come Dance With Me—Frank Sinatra—Capitol  
 1961—G.I. Blues—Elvis Presley—RCA Victor  
 1962—Modern Sounds in Country & Western Music—  
     Ray Charles—ABC Paramount  
 1963—First Family—Cadence  
 1964—Meet The Beatles—Capitol  
 1965—Beatles '65—The Beatles—Capitol  
 1966—Whipped Cream & Other Delights  
     —Herb Alpert & The Tijuana Brass—A&M/  
     Rubber Soul—Beatles—Capitol (Tie)  
 1967—More of the Monkees—Colgems  
 1968—Sgt. Pepper's Lonely Heart's Club Band—Beatles—Capitol  
 1969—Beatles—Apple  
 1970—Abbey Road—Beatles—Apple

## MOST PROGRAMMED MALE VOCALIST

- 1953—Eddie Fisher—RCA Victor  
 1954—Eddie Fisher—RCA Victor  
     Perry Como—RCA Victor (Tie)  
 1955—Perry Como—RCA Victor  
 1956—Perry Como—RCA Victor  
 1957—Frank Sinatra—Capitol  
 1958—Frank Sinatra—Capitol  
 1959—Frank Sinatra—Capitol  
 1960—Frank Sinatra—Capitol  
 1961—Frank Sinatra—Capitol/Reprise  
 1962—Frank Sinatra—Reprise  
     Elvis Presley—RCA Victor (Tie)  
 1963—Frank Sinatra—Reprise  
 1964—Frank Sinatra—Reprise  
 1965—Elvis Presley—RCA Victor  
 1966—Frank Sinatra—Reprise  
 1967—Frank Sinatra—Reprise  
 1968—Frank Sinatra—Reprise  
 1969—Glen Campbell—Capitol  
 1970—Tom Jones—Parrot  
     Elvis Presley—RCA (Tie)

## MOST PROGRAMMED STUDIO ORCH. INSTRUMENTALIST

- 1956—Les Baxter—Capitol  
 1957—Hugo Winterhalter—RCA Victor  
 1958—Billy Vaughn—Dot  
 1959—Ray Conniff—Columbia

## MOST PROGRAMMED FEMALE VOCALIST

- 1953—Patti Page—Mercury  
 1954—Patti Page—Mercury  
 1955—Rosemary Clooney—Columbia  
 1956—Jaye P. Morgan—RCA Victor  
 1957—Doris Day—Columbia  
 1958—Patti Page—Mercury  
 1959—Connie Francis—MGM  
 1960—Connie Francis—MGM  
 1961—Connie Francis—MGM  
 1962—Connie Francis—MGM  
 1963—Connie Francis—MGM  
 1964—Connie Francis—MGM  
 1965—Barbra Streisand—Columbia  
 1966—Petula Clark—Warner Bros.  
 1967—Petula Clark—Warner Bros.  
     Nancy Wilson—Capitol  
 1968—Petula Clark—Warner Bros.  
     Aretha Franklin—Atlantic (Tie)  
 1969—Aretha Franklin—Atlantic  
 1970—Dionne Warwick—Scepter

## MOST PROGRAMMED VOCAL GROUP

- 1953—Four Aces—Decca  
 1954—Four Aces—Decca/Hilltoppers—Dot (Tie)  
 1955—Four Aces—Decca/McGuire Sisters—Coral (Tie)  
 1956—Four Lads—Columbia  
 1957—Four Lads—Columbia  
 1958—Four Lads—Columbia  
 1959—Four Lads—Columbia/Four Freshmen—Capitol (Tie)  
 1960—Kingston Trio—Capitol  
 1961—Kingston Trio—Capitol/Everly Bros.—Cadence (Tie)  
 1962—Kingston Trio—Capitol  
 1963—Four Season—Vee Jay/Kingston Trio—Capitol (Tie)  
 1964—Beatles—Capitol  
 1965—Beatles—Capitol  
 1966—Beatles—Capitol  
 1967—Supremes—Motown/Monkees—Colgems (Tie)  
 1968—Beatles—Capitol/Monkees—Colgems—(Tie)  
 1969—Beatles—Apple  
 1970—Beatles—Apple

## MOST PROGRAMMED ORCHESTRA

- 1953—Ralph Flanagan—RCA Victor  
 1954—Ray Anthony—Capitol  
 1955—Ralph Marterie—RCA Victor  
 1956—Benny Goodman—Various Labels  
 1957—Les Brown—Columbia  
 1958—Ray Anthony—Capitol  
 1959—Ray Anthony—Capitol  
 1960—Les Elgart—Columbia  
 1961—Lawrence Welk—Dot  
 1962—Henry Mancini—RCA Victor  
     Billy Vaughn—Dot  
     Lawrence Welk—Dot  
     Si Zentner—Liberty (Tie)  
 1963—Lawrence Welk—Dot  
 1964—Henry Mancini—RCA Victor  
 1965—Henry Mancini—RCA Victor  
 1966—Herb Albert & The Tijuana Brass—A&M  
 1967—Herb Albert & The Tijuana Brass—A&M  
 1968—Herb Alpert—A&M  
 1969—Paul Mauriat—Philips  
 1970—Henry Mancini—RCA

## MOST PROMISING MALE VOCALIST

- 1953—Bob Manning—Capitol  
 1954—Lou Monte—RCA Victor  
 1955—Sammy Davis, Jr.—Decca  
 1956—Pat Boone—Dot  
 1957—Johnny Mathis—Columbia  
     Tommy Sands—Capitol (Tie)  
 1958—Jimmie Rodgers—Roulette  
 1959—Bobby Darin—Atco  
     Brook Brenton—Mercury (Tie)  
 1960—Jimmy Jones—Cub  
     Adam Wade—Coed (Tie)  
 1961—Adam Wade—Coed  
 1962—Jack Jones—Kapp  
     George Maharis—Epic (Tie)  
 1963—Jack Jones—Kapp  
     Bobby Vinton—Epic (Tie)  
 1964—Jack Jones—Kapp  
 1965—Tom Jones—Parrot  
 1966—Bob Lind—World Pacific  
     Frankie Randall—RCA Victor (Tie)  
 1967—Neil Diamond—Bang  
 1968—Glen Campbell—Capitol  
 1969—Jose Feliciano—RCA  
 1970—Joe Cocker—A&M





MAY 1969 — MAY 1970



THE BEATLES  
Get Back



Manufactured by Apple Records Inc., 1700 Broadway, New York, N.Y. 10019



THE BEATLES  
Ballad of John and Yoko

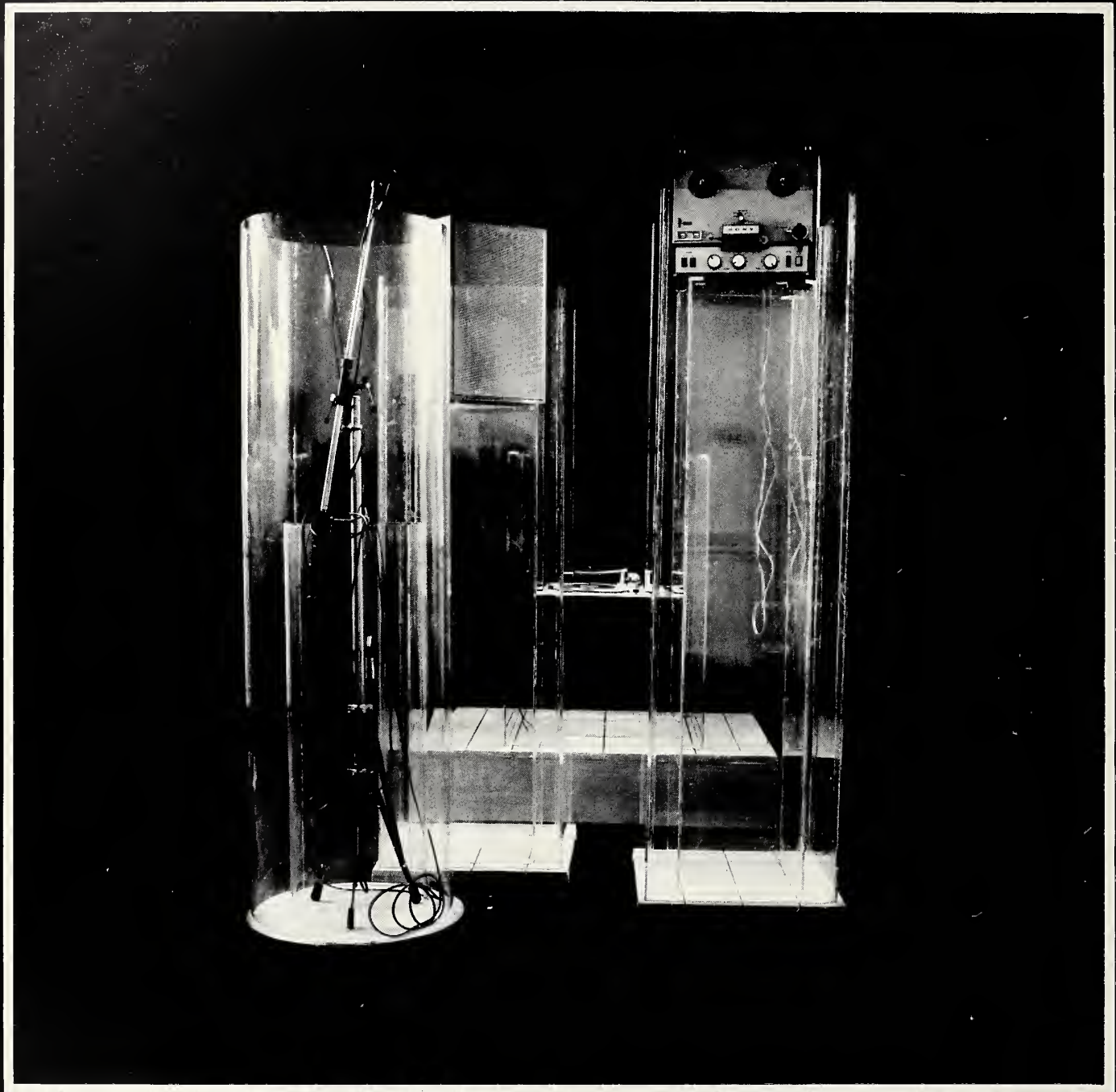

THE PLASTIC ONO BAND  
Give Peace A Chance



Manufactured by Apple Records Inc., 1700 Broadway, New York, N.Y. 10019



THE BEATLES  
Abbey Road

Manufactured by Apple Records Inc., 1700 Broadway, New York, N.Y. 10019





THE BEATLES  
Something / Come Together



Manufactured by Apple Records Inc., 1700 Broadway, New York, N.Y. 10019



THE PLASTIC ONO BAND  
Live Peace In Toronto

Manufactured by Apple Records Inc., 1700 Broadway, New York, N.Y. 10019





JOHN ONO LENNON  
Instant Karma



Manufactured by Apple Records Inc., 1700 Broadway, New York, N.Y. 10019





**BADFINGER**  
Come And Get It

Manufactured by Apple Records Inc., 1700 Broadway, New York, N.Y. 10019





THE BEATLES  
Hey Jude

Manufactured by Apple Records Inc., 1700 Broadway, New York, N.Y. 10019





THE BEATLES  
Let It Be

Manufactured by Apple Records Inc., 1700 Broadway, New York, N.Y. 10019



# McCartney



PAUL McCARTNEY  
McCartney



Manufactured by Apple Records Inc., 1700 Broadway, New York, N.Y. 10019



RINGO STARR  
Sentimental Journey

Manufactured by Apple Records Inc., 1700 Broadway, New York, N.Y. 10019





THE BEATLES  
The Long And Winding Road

Manufactured by Apple Records Inc., 1700 Broadway, New York, N.Y. 10019



# LET IT BE



THE BEATLES  
Let It Be

Manufactured by Apple Records Inc., 1700 Broadway, New York, N.Y. 10019





MARY HOPKIN



Manufactured by Apple Records Inc., 1700 Broadway, New York, N.Y. 10019



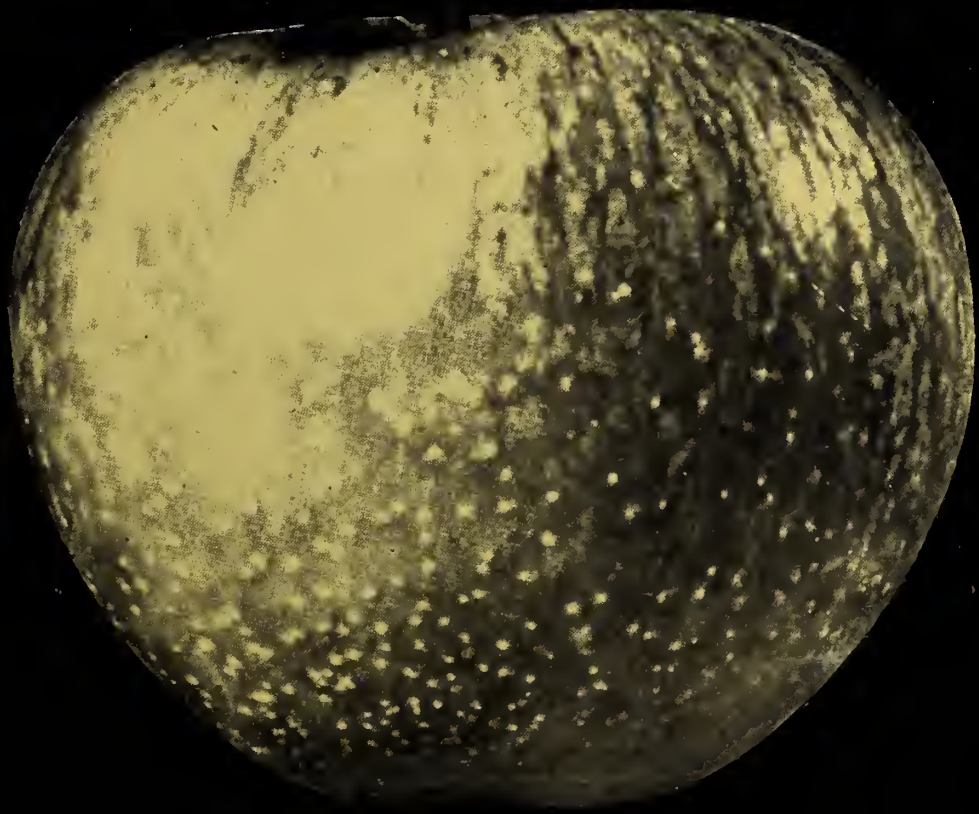

an **abkco** managed company



PHIL SPECTOR



Manufactured by Apple Records Inc., 1700 Broadway, New York, N.Y. 10019

## MOST PROMISING INSTRUMENTALIST

- 958—Champs—Challenge
- 959—Dave "Baby" Cortez—Clock
- 960—Bill Black's Combo—Hi
- 961—Jorgen Ingmann—Atco
- 962—Mr. Acker Bilk—Atco
- 963—Chantays—Dot/Bill Pursell—Columbia (Tie)
- 964—Pete Drake—Mercury
- 965—Horst Jankowski—Mercury
- 966—Herb Alpert & the Tijuana Brass—A&M
- 967—Walter Wanderly—Verve
- 968—Ravi Shankar—World Pacific
- 969—Mason Williams—WB/7 Arts
- 970—El Chicano—Kapp

## MOST PROGRAMMED INSTRUMENTALIST

- 958—Roger Williams—Kapp
- 959—Duane Eddy—Jamie/Guyden
- 960—Duane Eddy—Jamie/Guyden
- 961—Duane Eddy—Jamie/Guyden
- 962—Floyd Cramer—RCA Victor  
Ferrante & Teicher—United Artists (Tie)
- 963—Duane Eddy—RCA Victor
- 964—Al Hirt—RCA Victor
- 965—Al Hirt—RCA Victor
- 966—Herb Alpert & The Tijuana Brass—A&M
- 967—Roger Williams—Kapp
- 968—Al Hirt—RCA
- 970—Ferrante — Teicher

## MOST PROMISING ORCHESTRA

- 954—Les Elgart —Columbia
- 955—Richard Maltby—Vik
- 956—Dick Jacobs—Coral
- 957—Ray Conniff—Columbia
- 958—Ray Conniff—Columbia
- 959—Henry Mancini—RCA Victor
- 960—Si Zentner—Liberty
- 961—Bert Kaempfert—Decca
- 962—Si Zentner—Liberty
- 963—Joe Harnell—Kapp
- 965—Sounds Orchestral—Parkway
- 966—Herb Alpert & the Tijuana Brass
- 967—Bob Crewe Generation—Dyno Voio
- 968—Paul Mauriat—Philips
- 969—Paul Mauriat—Philips
- 970—Vincent Bell—Decca

## MOST PROMISING FEMALE VOCALIST

- 954—Kitty Kallen—Decca
- 955—Jay P. Morgan—RCA Victor
- 956—Gogi Grant—Era
- 957—Betty Johnson—Bally
- 958—Connie Francis—MGM
- 959—Dodie Stevens—Crystalette
- 960—Connie Stevens—Warner Bros.
- 961—Linda Scott—Canadian American
- 962—Joanie Sommers—Warner Bros.
- 963—Little Peggy March—RCA Victor
- 964—Barbra Streisand—Columbia
- 965—Petula Clark—Warner Brothers
- 966—Nancy Sinatra—Reprise
- 967—Sandy Posey—MGM
- 968—Lulu—Epic
- 969—Mary Hopkin—Apple
- 970—Melanie—Buddah

## MOST PROMISING VOCAL GROUP

- 954—Four Knights—Capitol
- 955—Hi-Lo's—Trend/DeCastro Sisters—Abbott (Tie)
- 956—Platters—Mercury
- 957—Hi-Lo's—Trend/Columbia
- 958—Four Preps—Capitol
- 959—Kingston Trio—Capitol
- 960—Brothers Four—Columbia
- 961—Limeliters—RCA Victor 62—Lettermen—Capitol
- 963—J's & Jamie—Columbia
- 964—Serendipity Singers—Philips
- 965—Seekers—Capitol
- 966—Mamas & the Pappas—Dunhill/Lovin' Spoonful—Kama Sutra (Tie)
- 967—Buckingham's—Columbia
- 968—Union Gap, Featuring Gary Puckett
- 969—Creedence Clearwater Revival—Fantasy  
Blood, Sweat and Tears—Columbia (Tie)
- 970—Jackson-Five—Motown/Chicago—Columbia (Tie)

# PAST WINNERS OF CASHBOX DJ POLLS

## ERROLL GARNER

total involvement . . . total communication

Management—  
Martha Glaser 520 Fifth Ave., New York, N.Y. 10036

## PICKWICK INTERNATIONAL, INC.

Keeps its world-wide Distribution Family busy and happy  
with a steady flow of releases & top values in pop & classical  
on Records, Tape Cartridges & Musicassettes  
on their famous labels

PICKWICK/33 —HILLTOP—PICKWICK SPOTLIGHT  
ALLEGRO—DESIGN—HAPPY TIME—SHOWCASE  
CRICKET—INSTANT LEARNING



Pickwick Bldg. 8-16 43rd Ave., Long Island City, N.Y. 11101  
U.S.A.—Tel-212-361-8811 — Cables Picksacor New York

# Record Manufacturers

**A. A.**  
250 W. 57th St. N.Y.C.

**AAA**  
6290 Sunset Blvd.  
Hollywood, Calif.

**A&M**  
1416 N. LaBrea  
Hollywood, Calif.

**ABC**  
1330 6th Ave., N.Y.C.

**AME**  
% Ariella  
185 West End Ave.  
N.Y.C. 10023

**ARC Custom**  
See American

**ARS**  
1242 W. Girard Ave.  
Phila., Pa. 19123

**ABBAY**  
160 Passaic Ave.  
Kearny, N.J.

**ABBOTT**  
% AA  
250 W. 57th St.  
N.Y.C.

**A-BET**  
1011 Woodland St.  
Nashville, Tenn. 37206

**ABKCO INDUSTRIES**  
1700 Broadway  
N.Y.C. 10019

**ABNAK**  
825 Olive  
Dallas, Tex. 75201

**ACADEMY**  
157 W. 57th N.Y.C.

**ACCENT**  
6533 Hollywood Blvd.  
Los Angeles 90028

**ACE**  
804 Vincent Bldg.  
Jackson, Miss.

**ACTA**  
6565 Sunset Blvd.  
Hollywood, Calif. 90028

**ACCENT**  
6533 Hollywood Blvd.  
Hollywood, 90028

**AD LIB**  
157 W. 57th St. N.Y.C.

**ALON**  
See Instant

**ADAIRE**  
1036 Red Bird Rd.  
Augusta, Ga.

**ADELL**  
200 W. 57th St.  
N., Y.C., 10019

**ADLER**  
683 Washington St.  
Boston, Mass.

**ADVANCE**  
6376 Yucca St.  
Hollywood, Calif. 90028

**AFRO-REQUEST**  
See Request

**AGP**  
See Bell

**AIRPORT**  
7102 1/2 Castor Ave.  
Phil., Pa. 19149

**AIRTOWN**  
723 N. 10th St.  
Richmond, Ind. 47374

**AJAX**  
1566 Stillwell Ave.  
Bronx, N.Y.

**AJP**  
119 W. 57th St.  
N.Y.C. 10019

**ALABAM**  
See McKinnon

**ALACOR**  
663 5th Ave.  
N.Y.C. 10022

**ALAMO**  
16508 S. Main St.  
Gardena, Calif.

**ALDEN**  
See CIRCA

**AL DEXTER**  
P.O. Box 71  
Denton, Texas 76201

**ALEGRE**  
See Roulette

**ALL PLATINUM**  
106 W. Palisades Ave.  
Englewood, N.J.

**ALLEY**  
213 E. Monroe  
Jonesboro, Ark.

**ALSHIRE INT'L**  
P.O. Box 7107  
Burbank, Calif. 91505

**ALSTON**  
See Atlantic

**ALTEEN**  
8208 So. Stony Island Ave.  
Chicago, Ill. 60619

**ALWIN**  
2645 W. Pico Blvd.  
Los Angeles, Calif. 90006

**AMARET**  
1717 No. Highland  
Hollywood, 90028

**AMAZON**  
See SSS Int'l

**AMBASSADOR**  
88 St. Francis St.  
Newark, N.J.

**AMCO**  
See CIRCA

**AMERICAN**  
7816 N. Interstate Ave.  
Portland, Ore. 97217

**AMERICAN DISK**  
See Adams Zetsch

**AMERICAN INT'L**  
210 5th Ave.  
N.Y.C. 10010

**AMERICAN RECORD SALES**  
1242 W. Girard Ave.  
Phila., Pa. 19123

**AMERICOM**  
12 E. 41 St.  
N.Y.C.

**AMIGO**  
6137 No. 6th St.  
Phila., Pa. 19120

**AMOS**  
See Bell

**AMPEX**  
555 Madison Ave. N.Y.C.

**AMRECO**  
See American

**AMSTERDAM**  
See Flying Dutchman

**AMY**  
1776 Broadway, N.Y.C. 10019

**ANCATH**  
P.O. Box 1036  
Alameda, Calif.

**ANCHOR**  
268 15th Ave.  
Newark, N.J.

**ANDO**  
See MU

**ANDREW JACKSON**  
Box 3912  
Dallas, Texas 75208

**ANGEL**  
Capitol Tower  
Hollywood, Calif.

**ANKH**  
11633 South Western Ave.  
L.A. 90047

**ANVIL**  
See Janus

**A.P.I.**  
3884 Franklin Ave.  
Los Angeles, Calif. 90027

**APPALOOSA**  
P.O. Box 1023  
Walnut Creek, Calif. 94596

**APPLE**  
1700 B'way  
N.Y.C. 10019

**APT**  
See ABC

**AQUARIAN**  
See Bell

**ARC**  
Sound City Records  
1214 Roosevelt  
Ames, Iowa

**ARCADE**  
2733 Kensington Ave.  
Philadelphia, Pa.

**ARCHIVE OF FOLK MUSIC**  
**ARCHIVE OF PIANO MUSIC**  
See Everest

**ARCHWAY**  
P.O. Box 7275  
St. Louis, Mo. 63177

**ARCTIC**  
See Jamie

**ARDENT**  
1457 National St.  
Memphis, Tenn. 38122

**ARHOOLIE**  
Box 5073  
Berkeley, Calif.

**ARIEL**  
c/o Progressive Media  
300 W. 55th St.  
N.Y.C.

**ARK**  
12418 Claudia Dr.  
Houston, Texas

**ARKAY**  
1851 Brunner St.  
Philadelphia, Pa.

**ARLEE**  
419 20th Ave., N.E.  
Hickory, N.C. 28601

**AROVOX**  
243 W. 18 St.  
N.Y.C.

**ARISTOPHONE**  
1564 Broadway, N.Y.C.

**ARTIA**  
160 Passaic Ave.  
Kearny, N.J.

**ARV Int'l**  
See Falcon

**ARWIN**  
250 N. Canon Dr.  
Beverly Hills, Calif.

**ARZEE**  
1739 N. 3rd St.  
Phila., Pa. 19122

**ASCOT**  
See United Artists

**ASSOCIATED ARTISTS**  
6367 Selma Ave.  
Hollywood, Calif. 90028

**ASTOR**  
CCM Bldg.  
1232 Cambridge St.  
Cambridge, Mass. 02139

**ASTRO**  
See Cotillion

**ATCO**  
1841 Broadway, N.Y.C.

**ATHENA**  
See Stereo Dimension

**ATLANNA**  
See McKinnon

**ATLANTIC**  
1841 Broadway, N.Y.C.

**ATLAS-ANGLETONE**  
1697 Broadway, N.Y.C.

**ATHENS OF THE SOUTH**  
815 16th Ave. South  
Nashville, Tenn.

**AUDIO ARTS**  
2552 W. Pico Blvd.  
Los Angeles, Calif. 90006

**AUDIO BLUES**  
See Audio Arts.

**AUDIO FIDELITY**  
221 W. 57th St. N.Y.C.

**AUDIO GOSPEL**  
See Audio Arts

**AURORA**  
241 W. 18th St.  
N.Y.C. 10011

**AVANT GARDE**  
250 W. 57th St., N.Y.C.

**AVCO EMBASSY**  
1301 Ave-of-The-Americas  
N.Y.C. 10019

**B. ATLAS**  
1697 Broadway  
N. Y. C. 10019

**BBC**  
P.O. Box 9747  
Atlanta, Ga.

**B.T. PUPPY**  
2 Pennsylvania Plaza  
N. Y. C. 10001

**B-W**  
P.O. Box 337  
Wooster, Ohio 44691

**BABY LUV**  
156 W. Chanstor Ave.  
Richmond, Calif.

**BACK BEAT**  
See Duke

**BAHAMAS**  
Box 174  
Nassau, Bahamas

**BAJA**  
4 Broad St. S.W.  
Atlanta, Ga.

**BAKERSFIELD**  
1223 No. Chester Ave.  
Bakersfield, Calif. 93308

**BAMBOO**  
See Scepter

**BANDBOX**  
5136 W. 41 St.  
Denver, Colo.

**BANDERA**  
3035 W. 38th St.  
Chicago, Ill.

**BANDSTAND**  
157-36 90th St.  
Howard Beach, N.Y.

**BANDSTAND USA**  
2445 Chelsea Ave.  
Memphis, Tenn. 38108

**BANG**  
1650 Broadway, N. Y. C.

**BANNER**  
Box 330  
Hendersonville, Tenn. 37075

**BARBIE**  
c/o Redisco  
1815 Guilford Ave.  
Baltimore, Md. 21202

**BARNABY**  
816 No. LaCienaga Blvd.  
Los Angeles, Calif. 90069

**BARON**  
1237 Dorre Dr.  
Troy, Mich. 48084

**BARONET**  
See CIRCA

**BAROQUE**  
See Everest

**BARRE**  
160 Wood St.  
Wilkes-Barre, Pa.

**BARRINGTON**  
P. O. Box 100  
Blacksher, Ga.

**BARRY**  
See Old Town

**BART**  
6000 Biscayne Blvd.  
Miami, Fla. 33138

**BAT**  
Box 522  
Salisbury, Md. 21801

**BATTLE**  
See Riverside

**BAY SOUND**  
c/o Caravelle Ltd.  
400 York Rd.  
Baltimore 21204

**BAY-TONE**  
1509 Fillmore St.  
San Francisco, Calif.

**BAZOOKA**  
17130 Ventura Blvd.  
Encino, Calif.

**BEACON**  
518 W. 50 St.

**BELL**  
1776 Broadway, N. Y. C.

**BELLAIRE**  
5008 Bissonnet  
Bellaire, Texas 77407

**BELMONT**  
P. O. Box 1763  
Hollywood, Calif.

**BEST**  
P.O. Box 33  
Mesilla Park, N.M.

**BESTWAY**  
9030 Harrett St.  
Los Angeles, Calif. 90069

**BETHEHEM**  
1540 Brewster Ave.  
Cincinnati, Ohio

**BETTY**  
2009 W. 69th St.  
Chicago, Ill.

**BEULAH**  
See McKinnon

**BEVERLY HILLS**  
6430 Sunset Blvd.  
Hollywood 90028

**BIG BEAT**  
1412 Snyder Ave.  
Philadelphia 19145

**BIG D**  
See Diamond Jim

**BIG COUNTRY**  
Box 701  
Nashville, Tenn.

**BIG 5**  
See Southern Sounds  
Blackberry Jam  
1306 W. Cerritos Ave. #B  
Anaheim, Calif. 92805

**BIG STYLE**  
P.O. Box 322  
W. Memphis, Ark.

**BIG YELLOW**  
63 Main St.  
Maynard, Mass. 01754

**BISCAYNE**  
711 W. 60th St.  
Chicago, Ill. 60621

**BIZARRE**  
See Warner Bros.

**BLACK FALCON**  
5 Freeport Pl. W.  
Freeport, N.Y. 11520

**BLACK GOLD**  
P.O. Box 8033  
Hollywood Station  
Memphis, Tenn.

**BLACK PRINCE**  
See SSS Int'l

**BLUE BIRD (OF ARKANSAS)**  
3901 E. Broadway  
N. Little Rock, Ark. 72114

**BLUE CAT**  
See Red Bird

**BLUE FOX**  
See SSS Int'l

**BLUE HILL**  
P.O. Box 7791  
Jacksonville, Fla. 32210

**BLUE HORIZON**  
146 W. 54th St.  
N.Y.C. 10019

**BLUE JAY**  
1821 Orleans Ave.  
New Orleans, La.

**BLUE NOTE**  
729 7th Ave.  
N.Y.C. 10019

**BLUE ONION**  
17914 Brazil Rd.  
Cleveland, Ohio 44119

**BLUE ROCK**  
See Mercury

**BLUE STAR**  
295 A Essex St.  
Hackensack, N.J. 07601

(Cont. on Next Pa

MEET A SCEPTER RECORDS EXECUTIVE IN THE YEAR  
2001

21ST CENTURY



**Barry Goff**  
AGE 4

WE'RE PLANNING AHEAD WITH CONFIDENCE

On LP's—8 Track—Cassettes

SCEPTER/WAND/HOB/TIFFANY/MACE & TODLIN' TOWN

and The Budget Tape Lines:

ORBIT & CELESTIAL

# Record Manufacturers

**BRITE-STAR**  
P. O. Box 56  
Newbury, Ohio

**BROOKE**  
Radio Bldg.  
Asheboro, N. C.

**BRUNSWICK**  
445 Park Ave., N. Y. C.

**BUCK**  
14610 Nimitz St.  
Houston, Texas

**BUCKLEY**  
1707 Church St.  
Nashville, Tenn.

**BUDDAH**  
1650 Broadway  
New York, N. Y. 10019

**BUDDY**  
500 Locust St.  
Marshall, Texas 75670

**BUDGET**  
See Request

**BUDGET SOUND**  
222 W. Orange Grove Ave.  
Burbank, Calif.

**BUENA VISTA**  
500 S. Buena Vista St.  
Burbank, Calif.

**BULLET**  
204 Grove St.  
Norwell, Mass. 02061

**BUNNY**  
c/o Best Bet Mgmt.  
1650 Broadway  
N. Y. C. 10019

**BURLAND**  
975 Prospect Ave.  
Bronx, N.Y. 10459

**BUTTERCUP**  
See Jubilee

**BUZZ**  
52-87 79 St.  
Elmhurst, N.J.

**CBG**  
1616 Argyle Ave.  
Hollywood, Calif.

**C'n W**  
See Guilford

**CVM**  
1017 1/2 So. Main St.  
Rockford, Ill. 61102

**CAB**  
975 Prospect Ave.  
Bronx, N.Y. 10459

**CADET**  
See Chess

**CAEDMON**  
505 8th Ave., N.Y.C. 10018

**CALENDAR**  
See RCA

**CAL-GOLD**  
See CIRCA

**CALLA**  
1631 B'way, N.Y.C. 10019

**CANDY**  
1410 Della St.  
Texarcana 75501

**CANYON**  
1242 No. Highland  
Hollywood, 90038

**CARMAY**  
13117 Lackwood Blvd.  
Downey, Calif.

**CAMDEN**  
See RCA Victor

**CAMELOT**  
937 South St.  
Philadelphia, Pa.

**CAMILLE**  
See Cab

**CANARY**  
439 Brewer Dr.  
Nashville 11, Tenn.

**CANARY**  
P.O. Box 1336,  
1021 Woodside Rd.  
Redwood, Calif. 94064

**CANDLELIGHT**  
410 Main St.  
W. Orange, N.J.

**CANTERBURY**  
9000 Sunset Blvd.  
Los Angeles, Calif. 90069

**CAPCITY**  
1028 Connecticut Ave. N.W.  
Washington, D.C. 20036

**CAPE**  
509 N. Kenwood  
Glendale, Calif.

**CAPITOL**  
Capitol Tower  
Hollywood, Calif.  
1290 Avenue of Americas

**CAPRI**  
4057 So. Prairie Ave.  
Chicago, Ill. 60653

**CAPRICORN**  
See Atlantic

**CARAVELLE, LTD.**  
400 York Rd.  
Baltimore, Md. 21204

**CARDBOARD**  
P.O. Box 325  
Baldwin Park, Calif. 91706

**CARIB**  
c/o Island Music Distributors  
P.O. Box 748  
Miami Springs, Fla. 33166

**CARNIVAL**  
24 Branford Pl.,  
Newark, N.J. 07102

**CAROLE**  
See Crescendo

**CARRIE**  
Box 7763  
Detroit, Mich.

**CATAMOUNT**  
2865 Kennedy Blvd.  
Jersey City, N.J. 07306

**CATCH**  
See Era

**CATHAY**  
P.O. Box 4212  
Flint, Mich. 48504

**CATHY**  
2547-20th Ave.  
San Francisco, Cal.

**CAVALCADE**  
23 Broad St.  
Bloomfield, N.J.

**CAVALIER**  
387 6th St.  
S.F., Calif.

**CELEBRITY CIRCLE**  
408 Olive St.  
St. Louis, Mo. 63102

**CELESTE**  
855 Majestic Ave.  
Norfolk, Va. 23504

**CELESTIAL**  
See DeVillie

**CELTIC**  
2403 Stewart Ave.  
Westbury, N.Y.

**CENTAUR**  
82 Aldine St.  
Rochester, N.Y.

**CENTER CITY**  
See McKinnon

**CENTURY**  
1429 Hawthorne St.  
Pittsburgh, Pa.

**CENTURY CITY**  
1801 Ave-of-the-Stars  
Los Angeles 90067

**CERTRON**  
1226 16 Ave. So.  
Nashville, Tenn. 37212

**CETRA OPERA**  
See Everest

**CEVETONE**  
130 Newark Ave.  
Jersey City, N.J.

**CFP**  
See Fuller

**CHA CHA**  
54 W. Randolph St.  
Chicago, Ill. 60601

**CHADWICK**  
See Carnival

**CHALET**  
812 16th Ave. So.  
Nashville, Tenn. 37203

**CHALLENGE**  
See Crew

**CHAMP**  
5113 5th Ave.  
Hollywood, Calif. 90043

**CHANCELLOR**  
116 Central Pk. South  
N.Y.C., 10019

**CHANNEL**  
6018 Henderson St.  
Chicago, Ill. 60634

**CHAPARRAL**  
1105 E. St. Charles Rd.  
Lombard, Ill. 60148

**CHAPTER ONE**  
See London

**CHART**  
806 16th Ave. So.  
Nashville, Tenn. 37203

**CHARTMAKER**  
6263 Leland Way  
Hollywood, Calif.

**CHASE**  
c/o Chips  
808 N. Broad St.  
Philadelphia, Pa.

**CHEATHAM**  
2016 N. Prairie  
Dallas, Texas

**CHECKER**  
320 E. 21st. St.  
Chicago, Ill.

**CHESTNUT**  
2020 Ridge Ave.  
Philadelphia 19121

**CHEVELL**  
P.O. Box 12276  
Ft. Worth, Texas 76116

**CHIPS**  
See Capitol

**CHISA**  
See Motown

**CHOICE**  
Box 5021  
Newark, N.J.

**CINEMA**  
3204 Broadway  
Houston, Texas 77017

**CIRCO**  
403 Rivet St.  
New Bedford, Mass. 02744

**CITATION**  
1619 Broadway  
N.Y.C. 10019

**CLARIDGE**  
6362 Hollywood Blvd.  
Hollywood 90028

**CLARION**  
See Adams, Zetsch

**CLARK**  
Box 400, Tinnin Rd.  
Goodlettsville, Tenn. 37072

**CLINTON**  
109 Clinton St.  
New Bedford, Mass.

**CO & CE**  
1601 Fifth Ave.  
Pittsburgh, Pa.

**COBBLESTONE**  
See Buddah

**COBURT**  
See MGM

**COED**  
1619 Broadway, N.Y.C.

**COLGEMS**  
See RCA

**COLISEUM**  
See London

**COLOSSUS**  
1855 Broadway  
N.Y.C.

**COLPAR**  
P.O. Box 4617  
Richmond, Va. 23229

**COLT**  
4803 Indiana Ave.  
Chicago, Ill. 60615

**COLT 45**  
2103 Penna Ave., N.W.  
Washington, D.C.

**COLUMBIA**  
51 W. 52nd St., N.Y.C.

**COMBO**  
6201 Santa Monica Blvd.  
Hollywood, Calif.

**COMMAND**  
See ABC

**COMMONWEALTH UNIT**  
745 5th Ave., N.Y.C. 10022

**CONCEPT**  
1041 N. Formosa  
Hollywood, Calif.

**CONCERT CLASSICS**  
111 W. 57th, N.Y.C.

**CONCERT DISC**  
See Everest

**CONCLAVE**  
1697 Broadway  
N.Y.C. 10019

**CONGRESS**  
See Kapp

**CONNOISSEUR**  
160 Passaic Ave.  
Kearney, N.J. 07032

**CONNOISSEUR SOCIETY**  
470 West End Ave.  
N.Y.C. 10024

**CONTEMPO**  
See UA

**CONTEMPORARY**  
8481 Melrose Place  
Los Angeles 36, Calif.

**CONTINENTAL**  
12 Irving St.  
Framingham, Mass. 01701

**CONVERSAPHONE**  
225 W. 34th St.  
N.Y.C. 10001

**COOKIN'**  
1136 Columbus Ave.  
Boston 20, Mass.

**COOL**  
617 Exchange Bldg.  
Nashville, Tenn.

**COPPER STATE**  
815 E. Braodway  
Tucson, Ariz. 85719

**CORAL**  
445 Park Ave., N.Y.C.

**CORONA**  
934 1/2 Olympic Blvd.  
Beverly Hills, Calif.

**CORONET**  
See Premier

**CORTLAND**  
1501 W. Cortland St.  
Chicago, Ill.

**COTILLION**  
See Atlantic

**COTIQUE**  
477 Park Ave.  
East Hartford, Conn. 01608

**COUGAR**  
Marlton Green Bldg.  
Rt. 70 & Greentree Rd.  
Cherry Hill, N.J. 08034

**COUN-TREE**  
4200 Missouri  
E. St. Louis, Mo.

**COUNTERPOINT**  
See Everest

**COUNTRY JUBILEE**  
Demorest, Ga.

(Con't on next Pa

**BLUE STAR**  
295 A Essex St.  
Hackensack, N.J. 07601

**BLUE THUMB**  
427 No. Canon Dr.  
Beverly Hills, Calif.

**BLUES TIME**  
See Flying Dutchman

**BLUE VALLEY**  
See MGM

**BLUESTOWN**  
1820 Washington St.  
Boston, Mass.

**BLUESVILLE**  
See Prestige

**BLUESWAY**  
See ABC

**BOARDWALK**  
114 S. Ocean Ave.  
Atlantic City, N. J.

**BOBBIE**  
17th & Sanson  
Philadelphia, Pa.

**BOBSHOSKY**  
531 Dell Ave.  
Logans Ferry Hts.  
New Kensington, Pa. 15068

**BOCART**  
25 W. 65th, N. Y. C.

**BO-MAR**  
See Guilford

**BOMARC**  
2721 Snyder Ave.  
Philadelphia, Pa.

**BOND**  
309 So. Broad St.  
Philadelphia 19107

**BONFIRE**  
See Jay-Jay

**BOOM**  
See ABC

**BOONE**  
119 Two Mile Pike  
Goodlettsville, Tenn.

**BOOTLEG**  
2012 Noble St.  
Pitts., Pa.

**BOSS**  
P. O. Box 144422  
Tampa, Fla.

**BOSS CITY**  
69 Ward Pl.  
Hartford, Conn. 06106

**BOUNTY**  
See Elektra

**BOURBON STREET**  
2939 Seratine St.  
New Orleans 19, La.

**BOUTIQUE**  
1697 Broadway, N. Y. C.

**BOYD**  
2609 N. W. 36th St.  
Oklahoma City, Okla.

**BRAGG**  
c/o John Capps  
728 16th Ave. S  
Nashville, Tenn.

**BRANDIN**  
See Champ

**BRASS**  
7807 Truman  
Kansas City, Mo.

**BRAVE**  
1404 Arlington Blvd.  
Falls Church, Va.

**BRAVO**  
See Viva

**BRITANIA**  
See Abnak



Ma Belle Amie TEE SET CS-1001



Colossus, where wonders never cease.



THE SHOCKING BLUE CS-1000



Little Green Bag  
GEORGE BAKER SELECTION CS-1002



KANNIBAL KOMIX CS-1004

We are currently seeking new additions  
to our extensive collection of fine  
European and American Masters.  
Inquiries invited.

Colossus Records

Also available on Ampex Cassette and 8-Track Tape

# Record Manufacturers

**COVER**  
577 Sharon Dr.  
Memphis, Tenn.

**COWTOWN**  
P.O. Box 192  
Avery, Texas

**COX**  
2510 Rountree  
Abilene, Texas

**CRACKERJACK**  
See Sue

**CRAZY HORSE**  
See Capitol

**CREATIVE SOUND**  
9000 Sunset Blvd.  
Los Angeles, Calif. 90069

**CRESCENDO**  
3725 Crescent St.  
Long Island City, N.Y. 11101

**CRESCENT**  
See A-bet

**CREST**  
See CIRCA

**CREWE**  
1841 Broadway  
N.Y.C. 10023

**CRIMSON**  
1005 Chestnut St.  
Philadelphia, Pa. 19107

**CRITERIA**  
31 W. Market St.  
Akron, O. 44308

**CROSS**  
See AJP

**CROSS-WINDS**  
Rte. #2, Box 361-A  
Lake Elsinore, Cal. 92330

**CROWN**  
1435 So. LaCrensga  
Los Angeles, Calif.

**CTI**  
36 E. 57th St.  
N.Y.C. 10022

**CUB**  
See MGM

**CUCA**  
123 Water St.  
Sauk City, Wisc.

**CURRENT**  
313 N. Virginia St.  
Ontario, Calif.

**CURTOM**  
See Buddah

**CYCLONE**  
See Bell

**CYPHER**  
50 E. 42nd St.  
N.Y.C.

**CYPRESS GARDEN**  
See McKinnon

**DC**  
930 F. Street, N.W.  
Suite 1615  
Washington, D.C.

**DCP**  
729 Seventh Ave., N.Y.C.

**DJM**  
See Bell

**DMA**  
645 No. Michigan  
Chicago, Ill. 60611

**D.P.G.**  
c/o East Coast Dist.  
612 E. Liberty  
Norfolk, Va.

**DW**  
Box 1945/Glendale, Calif. 91209

**DAMON**  
117 W. 14th St.  
Kansas City, Mo. 64116

**DANA**  
Box 786  
West Covina, Calif. 91790

**DANCE ALONG**  
111 W. 57th St., N.Y.C. 10019

**DANCO**  
See Elvitruie

**DANIELS**  
2648 W. Washington Blvd.  
Chicago 60612

**DANRITE**  
2705 National Circle  
Garland, Texas 75040

**D'ARCY**  
417 W. 21st St.  
Norfolk, Va. 23517

**DARAN**  
4148 S. King Dr.  
Chicago, Ill. 60653

**DARE**  
P.O. Box 2055  
Bell Gardens, Calif.  
90201

**DATA**  
1607 El Centro Ave.  
Hollywood, 90028

**DATE**  
51 W. 52nd St., N.Y.C.

**DAVID**  
1650 Broadway, N.Y.C.

**DAVIS**  
3301 W. Flourney  
Chicago, Ill.

**DAVON**  
See Horizon

**DAWN**  
c/o Steady

**DAY DELL**  
c/o Jamie/Guyden  
919 N. Broad St.  
Philadelphia, Pa.

**DE'BESTH**  
P.O. Box 171  
Hammond, Ind. 46320

**DE VILLE**  
1607 El Centro  
Hollywood, Calif.

**DEARBORN**  
13200 W. Warren  
Dearborn, Mich.

**DEB-MOR**  
200 W. 57th St.  
N.Y.C. 10019

**DEBUT**  
7501 Buist Ave.  
Philadelphia, Pa. 19153

**DECCA**  
445 Park Ave., N.Y.C.

**DEESU**  
1211 St. Philip St.  
New Orleans, La. 70116

**DEITY**  
See W.B.

**DE-LITE**  
300 W. 55th St.  
N.Y.C. 10019

**DEL-MAR**  
186 Rogers St.  
Atlanta, Ga.

**DEL NORTE**  
711 Wooland N.W.  
Albuquerque, N.M.

**DEL-RAY**  
5168 Franklin Ave.  
Hollywood, Calif.

**DEL-TONE**  
6363 Sunset Blvd.  
Hollywood, Calif.

**DELAWARE**  
116 Gentry Court  
Roselle, Ill.

**DELL-BRUCE**  
P.O. Box 57902  
1874 Mirabeau Dr.  
New Orleans 70122

**DELTA INT'L**  
1584 E. 31st St.  
Cleveland, Ohio 44114

**DELUXE**  
1540 Brewster Ave.  
Cincinnati, Ohio

**DERAM**  
See London

**DERBY TOWN**  
154 Spring St.  
Charlestown, Ind.

**DERRY**  
13380 Capitol Ave.  
Detroit, Mich.

**DESERT GOSPEL**  
815 E. Broadway  
Tucson, Ariz. 85719

**DESIGN**  
See Pickwick

**DESSA**  
Rte 1, Box 280  
Odessa, Texas 79760

**DESTINATION**  
See U.S.A.

**DEVILLE**  
1607 El Centro  
Hollywood, Calif.

**DEUTSCHE-GRAMMOPHON**  
See MGM

**DIABLO**  
3518 Champlain Ave.  
Youngstown, Ohio 44502

**DIADON**  
5607 Melrose Ave.  
Hollywood, Calif.

**DIAL**  
See Atlantic

**DIAMOND**  
1650 Broadway, N.Y.C.

**DIAMOND JIM**  
12318 Dexter Blvd.  
Detroit, Mich. 48206

**DIONN**  
See Jamie

**DIRECTIONAL SOUND**  
See Premier

**DISCOSCENE**  
4030 Chestnut St.  
Phila., Pa. 19104

**DISNEYLAND**  
500 S. Buena Vista St.  
Burbank, Calif.

**DISSO**  
See Adams-Zetsch

**DISTINCT**  
c/o Kay-May Prod.  
231 Myrtle Ave.  
Irvington, N.J. 07111

**DISTINGUISHED**  
See Scepter

**DITTO**  
See Bluestown  
1820 Washington St.  
Boston, Mass.

**DI VENUS**  
1122 Rhineland Ave.  
Bronx N.Y. 10461

**DOCK-MACK**  
2537 Adams Ave.  
San Diego, Calif.

**DOCUMENTARIES, UNLIMITED**  
1201 34th Ave., L.I.C.,  
N.Y.

**DOLTON**  
See Liberty

**DOMAIN**  
1313 North Ave.  
Hollywood 28, Calif.

**DOMINO**  
See Di Venus

**DON-EL**  
2020 Ridge Ave.  
Philadelphia, Pa.

**DON JOE**  
1055 Mulberry  
Wyandotte, Mich. 48192

**DOOTO**  
13440 So. Central Ave.  
Los Angeles, Calif.

**DORA**  
564 W. 160th St.  
N.Y.C.

**DORE**  
1608 Argyle  
Hollywood, Calif.

**DORIAN**  
1815 N. Kenmore Ave.  
Hollywood 27, Calif.

**DOT**  
1507 No. Vine St.  
Los Angeles, Calif. 90028

**DOUBLE SHOT**  
6515 Sunset Blvd.  
Hollywood, Calif.

**DOUGLAS INT'L**  
See Pickwick

**DOVER**  
748 Camp St.  
New Orleans, La. 70130

**DOWNBEAT**  
See Golden Artists

**DOWNEAST**  
8 E. 48th St.  
N.Y.C. 10017

**DOWNEY**  
13117 Lakewood Blvd.  
Downey, Calif.

**DRANDELL**  
2106 5th Ave.  
Los Angeles, Calif.

**DREW**  
18292 Wyoming Ave.  
Detroit, Mich. 48221

**DRUM BOY**  
c/o Jay Jay

**DRUM MAJOR**  
See SSS Int'l

**DRUMMOND**  
13380 Capitol Ave.  
Oak Park, Mich.

**D-TON**  
108 University  
San Antonio, Texas

**DUANE**  
P.O. Box 6174  
Albany, Calif. 94716

**DUB**  
P.O. Box 275  
Nashville, Tenn.

**DUKE**  
2809 Erastus St.  
Houston 26, Texas  
(Con't. on next Page)

# REQUEST RECORDS

*Leads the*  
**INTERNATIONAL FIELD**  
*with*  
**MUSIC OF MANY LANDS**  
beautifully packaged

featuring the finest  
AFRICAN/ALBANIAN/AMERICAN  
ARABIC/ARMENIAN/AUSTRIAN/BALINESE  
BRAZILIAN/BULGARIAN/CANADIAN/CAUCASIAN  
CUBAN/CZECHOSLOVAKIAN/FRENCH/GERMAN  
GREEK/GUIANIAN/GYPSY/HAITIAN/HUNGARIAN  
INDIAN/IRISH/ISRAELI/ITALIAN/JAPANESE/JEWISH  
KOREAN/LATIN AMERICAN/LITHUANIAN/MEXICAN  
POLISH/PORTUGUESE/ROUMANIAN/RUSSIAN  
SCOTTISH/SPANISH/TURKISH/UKRAINIAN  
WEST INDIAN/YIDDISH/YUGOSLAVIAN  
artists . . . and many more to come

Distribution for Some Countries Still Available

ALSO 8 TRACK CARTRIDGES AND CASSETTES

## REQUEST RECORDS

66 Mechanic Street, New Rochelle, N. Y. 10801  
Telephone 914 633-6055, 914 633-6059



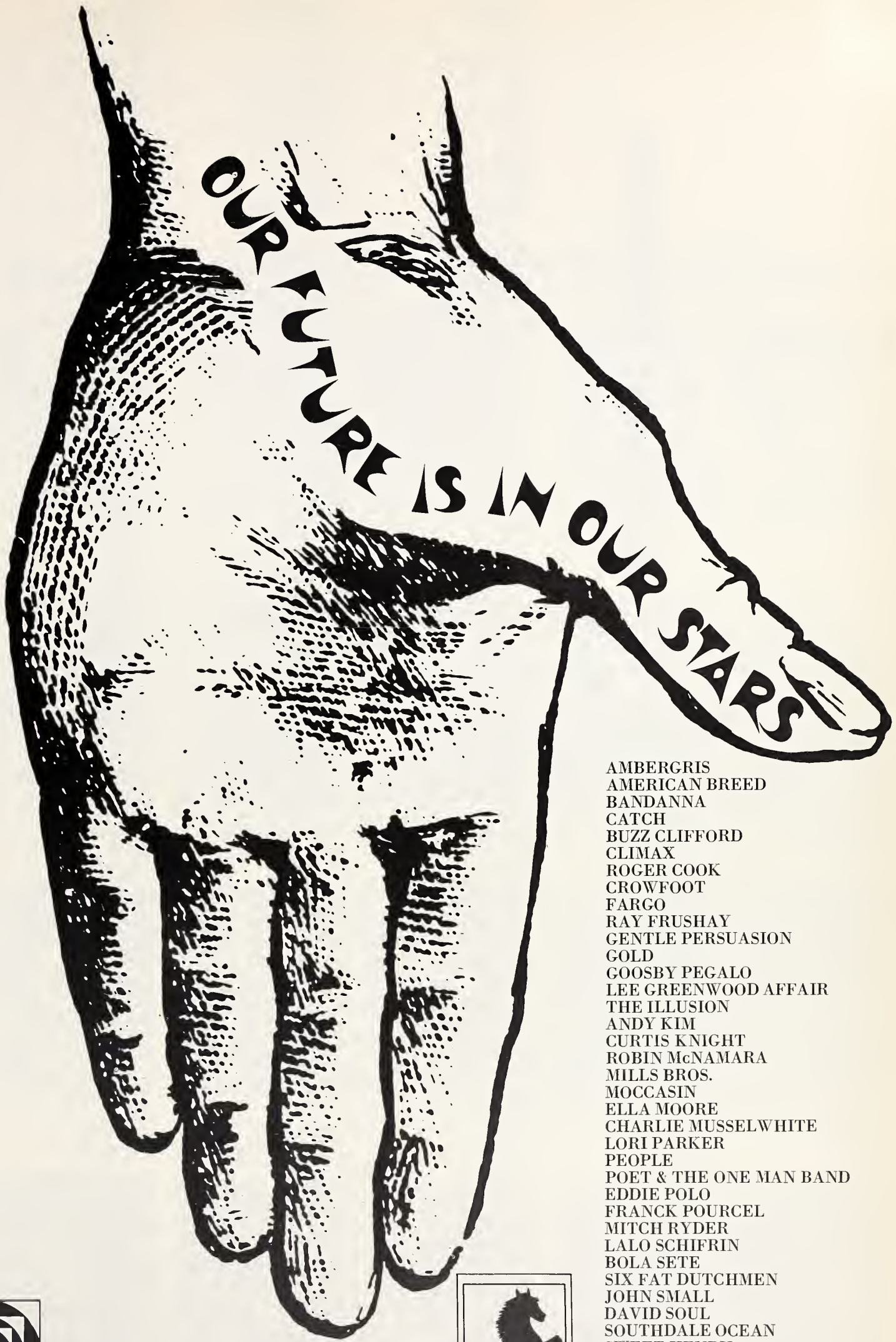

AMBERGRIS  
AMERICAN BREED  
BANDANNA  
CATCH  
BUZZ CLIFFORD  
CLIMAX  
ROGER COOK  
CROWFOOT  
FARGO  
RAY FRUSHAY  
GENTLE PERSUASION  
GOLD  
GOOSBY PEGALO  
LEE GREENWOOD AFFAIR  
THE ILLUSION  
ANDY KIM  
CURTIS KNIGHT  
ROBIN McNAMARA  
MILLS BROS.  
MOCCASIN  
ELLA MOORE  
CHARLIE MUSSELWHITE  
LORI PARKER  
PEOPLE  
POET & THE ONE MAN BAND  
EDDIE POLO  
FRANCK POURCEL  
MITCH RYDER  
LALO SCHIFRIN  
BOLA SETE  
SIX FAT DUTCHMEN  
JOHN SMALL  
DAVID SOUL  
SOUTHDAL OCEAN  
SWEET HENRY  
THE SWEET  
ANTHONY SWETE  
TRIANGLE  
UNIQUES  
URBAN RENEWAL  
BILLY VAUGHN  
GEORGE WRIGHT



A DIVISION OF FAMOUS MUSIC CORP.

A GULF+WESTERN COMPANY

# Record Manufacturers

**EXPRESS**  
711 Crescent  
Memphis, Tenn.

**FGF**  
9416 Highland Pl.  
Arvada, Colo.

**FABOR**  
2609 W. Olive  
Burbank, Calif.

**FABRI**  
5533 Hollywood Blvd.  
Hollywood 90028

**FAGYEES**  
See Ancath

**FAIRLANE**  
See King

**FAIRMOUNT**  
See Cameo Paveway

**FAIRWAY INT'L**  
2221 W. Olive  
Burbank, Calif.

**FAITH SPECIAL**  
254 E. 29th St.  
L.A. 90011

**FALCON**  
McAllen, Texas

**FALEW**  
1270 Sixth Ave.  
N.Y.C.

**FAME**  
See Capitol

**FAMILY**  
See Request

**FAMOND**  
2626 Swift Ave.  
Cincinnati, Ohio 45212

**FANIA**  
850 7th Ave.  
N.Y.C. 10019

**FANNIN**  
Rte. 1, Box 56 B  
Blue Ridge, Ga.

**FANTASY**  
1281 30th St.  
Oakland 94608

**FARO**  
544 N. Western Ave.  
Hollywood, Calif. 90038

**FEDERAL**  
1540 Brewster Ave.  
Cincinnati, Ohio

**FELSTED**  
See London

**FESTIVAL**  
See King

**FIDELITY**  
8508 Sunset Blvd.  
Hollywood 46, Calif.

**FIASCO**  
See Audio Engineering

**FIESTA**  
1619 Broadway, N.Y.C.

**FILLMORE**  
See Epic

**FILMWAYS**  
See Valiant

**FINER ARTS**  
60 So. Glenco St.  
Denver, Colorado 80222

**FIREBALL**  
P.O. Box 50576  
New Orleans 70150

**FIREBALL**  
P.O. Box 50576  
New Orleans 70150

**FIVE-O**  
8344 So. Carpenter  
Chicago, Ill.

**FLAG**  
P.O. Box 827  
Lucedale, Miss.

**FLAMINGO**  
105-21 66th Ave.  
Forest Hills, N.Y.

**FLAT-GIT-IT**  
11703 E. Everest St.  
Norfolk, Calif.

**FLICK**  
18424 Gallagher  
Detroit 34, Mich.

**FLICK CITY**  
6565 Sunset Blvd.  
Hollywood 90028

**FLICK DISC**  
See MGM

**FLIP**  
618 S. Ridgeley Dr.  
Los Angeles, Calif.

**FLORIDA**  
453 W. 27th  
Hialeah, Fla.

**FLYING DUTCHMAN**  
65 W. 55th St.  
N.Y.C. 10019

**FOCUS**  
See Atlantic

**FOGGY MOUNTAIN**  
P.O. Box 1692  
Phoenix, Ariz. 85001

**FOLKWAYS**  
165 W. 46th St. N.Y.C.

**FONTANA**  
See Mercury

**FORD**  
756 7th Ave.  
N.Y.C. 10019

**FORMAT**  
506 Newberry Ct.  
Joppatown, Md. 21087

**FORTE**  
840 Kalamazoo S.E.  
Gr. Rapids, Mich. 49507

**FORTUNE**  
3942 Third Ave.  
Detroit, Mich.

**FORUM**  
See Roulette

**FORWARD**  
9000 Sunset Blvd.  
Los Angeles 90069

**4 CORNERS**  
See Kapp

**FOUR BROTHERS**  
3234 W. Roosevelt Rd.  
Chicago, Ill.

**400/PLUS**  
See Monument

**FOUR STAR**  
305 S. Fair Oaks Ave.  
Pasadena, Calif.

**FRATERNITY**  
Rm. 105  
Sheraton Gibson Hotel  
Cincinnati, Ohio

**FREEDOM**  
6920 Sunset Blvd.  
Hollywood, Calif.

**FRIENDLY**  
Cornelia, Ga.

**FROG**  
23 Maryland Ave.  
Bay Shore, N.Y. 11706

**FROLIC**  
4965 Bruce Dr.  
Beaumont, Texas

**FROS RAY**  
2707 W. Pico Blvd.  
Los Angeles, Calif. 90006

**FROST**  
1204 So. B St.  
San Mateo, Calif.

**FULLER**  
P.O. Box 10513  
Tampa, Fla. 33609

**FULTON**  
723 E. 81 St.  
Brooklyn, N.Y.

**FUN**  
660 Madison Ave.  
N.Y.C. 10021

**FUTURE**  
1086 East College Ave.  
Batesville, Ark.

**GJM**  
875 Main St.  
Buffalo, N.Y. 14203

**GNP**  
9165 Sunset Blvd.  
Hollywood 28, Calif.

**GRT**  
9000 Sunset Blvd.  
L.A. 90069

**GWP**  
150 E. 52nd St.  
NYC. 10022

**GAMA**  
930 F St. N.W.  
Suite 615  
Washington, D.C. 20004

**GALAXY**  
See Fantasy

**GAMBLE**  
1650 B'way, N.Y.C. 10019

**GAME TIME**  
1650 B'way, N.Y.C.

**GAMBIT**  
See CIRCA

**GANIM**  
6362 Hollywood Blvd.  
Hollywood, Calif.

**GARPAX**  
Box 669  
Hollywood, Calif.

**GASS**  
1 No. Cass Ave  
Westmont, Ill. 60559

**GATEWAY**  
234 Forbes Ave.  
Pittsburgh, Pa.

**GAYLE**  
6376 Yucca St.  
Hollywood, 90028

**GAYNOTE**  
See Coast

**GAZETTE**  
See Columbia

**GEMA**  
659 10th Ave.  
N.Y.C. 10036

**GEMINI**  
c/o Assoc. Ind.  
256 5th Ave.  
Pittsburgh 15219

**GENERATION**  
See Crewe

**GERIM**  
744 E. 79th St.  
Chicago 60619

**GHOST**  
1905 Pesos Pl.  
Kalamazoo, Mich. 49001

**GLAD-HAMP**  
165 W. 45th St. N.Y.C.

**GLOBAL THEATER**  
15456 Cabrito Rd.  
Van Nuys 91406

**GLOVER**  
1697 Broadway, N.Y.C.

**GMC**  
1595 Broadway  
N.Y.C. 10019

**GO GO**  
19 Southland Dr.  
Glen Cove, N.Y.

**GOLD ARROW**  
See Circa

**GOLDBAND**  
P.O. Box 254  
Lake Charles, La.

**GOLD STANDARD**  
Box 35  
Nashville, Tenn.

**GOLD WAX**  
2445 Chelsea Ave.  
Memphis, Tenn.

**GOLDEN**  
250 W. 57th St.  
NYC. 10019

**GOLDEN TRIANGLE**  
342 W. State St.  
Trenton, N.J. 08608

**GOLDEN CREST**  
220 Broadway  
Huntington Station, N.Y.

**GOLDEN CROSS**  
See Gusman

**GOLDEN GROOVE**  
300 Mt. Lebanon Blvd.  
Suite 228  
Pittsburgh, Pa. 15234

**GOLDEN LEAF**  
1663 Eddington Rd.  
Cleveland Heights, Ohio

**GOLDEN OF LA.**  
P.O. Box 2544  
Baton Rouge, La. 70802

**GOLDEN STATE**  
665 Harrison  
San Francisco, Calif.

**GOLDEN WORLD**  
4039 Buena Vista  
Detroit, Mich.

**GOLIATH**  
1717 No. Vine St.  
Hollywood 90028

**GOOD TIME JAZZ**  
8481 Melrose Place  
Los Angeles 46, Calif.

**GORDO**  
544 No. Western Ave.  
L.A. 90004

**GORDON ST.**  
See McKinnon

**GORDY**  
See Tamla

**GOSPEL**  
See Savoy

**GOTTA GO**  
1413 Eads St.  
Bristol, Va. 24201

**GRAHAM**  
See Circa

**GRAND AWARD**  
1330 6th Ave. N.Y.C.

**GRANDE**  
1650 Broadway  
N.Y.C. 10019

**GRAPEVINE**  
See GWP

**GREAT AMERICAN**  
P.O. Box 6032 Sta-B  
Miami, Fla. 33126

**GRECOPHON**  
See Fiesta

**GREGAR**  
See RCA

**GREGG**  
101 N. 8th St.  
Ft. Smith, Ark. 72901

**GREGORY**  
See Airtown

**GROOVE**  
See RCA Victor

**GROOVESVILLE**  
517 Pavilion  
1 Lafayette Plaisance  
Detroit, Mich. 48207

**GROOVY GROOVES**  
2200 Franklin Pkwy.  
Philadelphia, 19130

**GRT**  
9000 Sunset Blvd.  
L.A. Calif. 90069

**GUILFORD**  
c/o Redisco  
1815 Guilford Ave.  
Baltimore, Md. 21202

**GUITARVILLE**  
222 E. Garvey  
Monterey Pk., Calif.

**GULF**  
157 W. 57th St., N.Y.C.

**GUSMAN**  
P.O. Box 9202  
Savannah, Ga. 31402

**GUY**  
310 W. 73rd St. N.Y.C.

**GUYDEN**  
See Jamie

**H.I.T.**  
See DeVille

**HSH**  
See NRS

**HALIFAX**  
4135 Armitage  
Chicago 39, Ill.

**HALLMARK**  
123 Ave. U  
Brooklyn, N.Y.

**HALO**  
Box 7481  
10 Michael Dr.  
Greenville, S.C. 29610

(Con't on next Page)

**DUNHILL**  
449 S. Beverly Dr.  
Beverly Hills, Calif.

**DUO**  
See Stereodiddies

**DYER-BENNETT**  
P.O. Box 235  
Woodside 77, N.Y.

**DYNAMO**  
See Musicor

**EAGLE**  
1697 Broadway  
N.Y.C. 10019

**EARTH**  
322 W. 48th St.  
N.Y.C.

**EDEN**  
See Era

**EEE CEE**  
410 West End Ave.  
N.Y.C. 10024

**EL CON**  
561 W. 161st St.  
N.Y.C. 10032

**ELEKTRA**  
1855 B'way, N.Y.C.

**ELEPHANT V**  
See Roulette

**ELEUTHERA**  
See Buddha

**ELF**  
See Bell

**ELVITRUE**  
306 S. 16th St.  
Wilmington, N.C. 28401

**EMBER**  
See Buddha

**EMBER INT'L**  
Ste. 1203  
161 W. 54th St., N.Y.C.

**EMBRYO**  
See Cotillion

**ENRICA**  
1674 Broadway  
New York 10019

**ENTERPRISE**  
See Stax

**EPIC**  
51 W. 52 St. N.Y.C.

**ERA**  
6464 Sunset Blvd.  
Hollywood, Calif. 90028

**ESOTERIC**  
See Everest

**ESP-DISK**  
300 W. 55th St.  
New York, N.Y. 10019

**ESQUIRE**  
11410 1/2 Hempstead Hwy.  
Houston, Texas

**ETCETERA**  
See Atlantic

**ETIQUETTE**  
P.O. Box 582  
Tacoma 1, Wash.

**EUREKA**  
331 Reeves Dr.  
Beverly Hills, Calif.

**EUROTONE**  
130 W. 42nd St.  
N.Y.C. 10036

**EVENT**  
201 W. 54th St. N.Y.C. 10019

**EVEREST**  
10920 Wilshire Blvd.  
Hollywood, Calif.

**EVERGREEN**  
1105 E. St. Charles R.  
Lombard, Ill. 60148

**EVOLUTION**  
See Stereo Dimension

**EXCELLO**  
See A-Bet

**EXCLUSIVE**  
617 Exchange Bldg.  
Nashville, Tenn.

**EXOTIC**  
Box 36 Oakland Gardens, Queens  
Flushing, N.Y. 11364

# 5

## Years, and some changes at Warner/Reprise

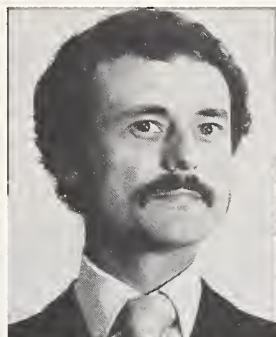

**Mo Ostin** Once a conservative CPA-type specializing in recordings by Sinatra-Martin-& Co., he's now Warner/Reprise's president. He also is rumored secretly to have burned his once extensive collection of Nehru shirts.

**Ian Ralfini** A slender English lad who discarded the once-seemingly-inevitable bowler hat for fetching sideburns and the spectacularly successful (and only a year old) Warner Bros. Records of England, Ltd.

**Joe Smith** In a former incarnation, Joe was Boston's top-forty DJ king slamming it to the kids over WBZ. He's come along, and now rates as Exec. VP for the company. A just reward for co-existing five years with The Grateful Dead.

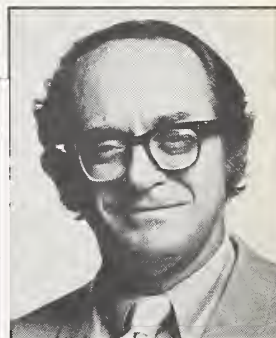
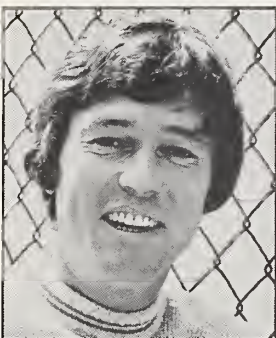

**Clyde Bakkemo** Farlier, Clyde was an L.A. promo man in a shiny sharkskin, touting our Connie Stevens singles. Since, he's become Assistant General Manager for the Warner Bros. label. And more relaxed.

**Hal Halverstadt** Once a cherubic opera fanatic and editor of a New York magazine aimed at pot throwers, Hal now heads our merchandising forces, and has forsaken Callas for Miss Mercy of The GTO's.

**Joel Friedman** Marketing VP for Warners now, and handsomely ruffled o'er his collar, Friedman in earlier days lived in a modest tract home in the San Fernando Valley. Now he refers to Phil Ochs as something of a right-winger.

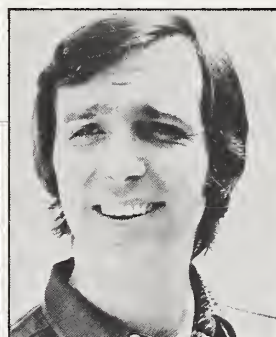
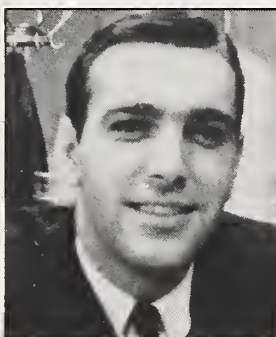

**Ed Thrasher** Years back, Ed was doing all those smiling Jackie Gleason-Al Martino covers for Capitol. Since the revolution, our shaggy Art Director seems more at home with Arlo Guthrie and Neil Young. He's even beginning to resemble them.

**Don Schmitzerle** A while back, Don was our on-the-streets promo guy in Detroit, swilling rum-and-cokes with the Motor City's influenceable DJs. Well, Don just came back from vacation with a face full of hair, the better to resemble his job as Assistant General Manager for Reprise.

**Ed West** When sideburns started lengthening in the office of our erstwhile Treasurer, the Harry Fox auditors started looking a little more nervous. No matter. He'll always be Honest Ed to us.

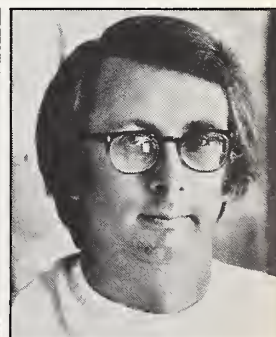
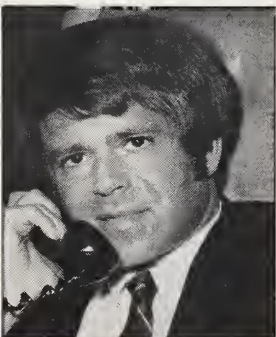

**Ron Saul** In high school, our National Promo Man had stylishly crew cut locks, and danced a lot to Chubby Checker records. Lately, his hair has blossomed into handsome loops under the stimulus of such shaggies as Norman Greenbaum and The Fugs.

**Phil Rose** Our international veep, Rose came to Burbank from Canada, where his super-straight reputation had once made him matinee idol of his college drama society. He currently is active explaining Frank Zappa to our South America licensees.

**Stan Cornyn** Often referred to in the past as "Prof" by the teenage girls he assaulted, Creative Services veep sprouted shaggy after an early trip to Golden Gate Park, where he learned that academics is not everything. He then took up writing saucy ads and wearing breath-takingly tight pants.

Keeping up with the times is not all hair. Totally hairless, the men at Warner/Reprise would still be ahead of the game. It is for that reason that their record labels are in many circles referred to as THE GOLD DUST TWINS.

# Record Manufacturers

**HAMMOND**  
P.O. Box 2063  
Baton Rouge, La.

**HANNA BARBERA**  
3400 W. Kahvenga  
Hollywood, Calif.

**HAPPY TIGER**  
6565 Sunset Blvd.  
Los Angeles 90028

**HARBOUR**  
See Buddah

**HARMONY**  
c/o Columbia

**HARVEST**  
See Capitol

**HARVEST TIME**  
See Alacor

**HEAD**  
See Chess

**HEART & SOUL**  
888 8th Ave.  
New York, N.Y.

**HEARTWARMING**  
136 4th Ave. No.  
Nashville 37219

**HEIDI**  
See Bellaire

**HEIGH-HO**  
1674 Broadway, N.Y.C.

**HEMISPHERE**  
See Golden Triangle

**HENDON**  
See Mira

**HEP**  
2551 Aldine N.  
St. Paul, Minn. 55113

**HERITAGE**  
1855 Broadway  
N.Y.C. 10023

**HI**  
See London

**HIBACK**  
6311 Yucca St.  
Hollywood, Calif. 90028

**HICKORY**  
2510 Franklin Rd.  
Nashville, Tenn.

**HIFI-RECORD**  
See Everest

**HI-HO**  
P.O. Box 8135  
Chicago 60680

**HILLCREST**  
Box 6278  
Bakersfield, Calif.

**H.I.P.**  
See Stax

**HIT**  
1743 Portsmouth Rd.  
Clearwater, Fla. 33516

**HIT KINGDOM**  
See McKinnon

**HIT PARADER**  
Capitol Dist., Co.  
Derby, Conn.

**HITSVILLE**  
28 King St.  
Old Saybrook, Conn.

**HOB**  
See Scepter

**HOLIDAY INN**  
3796 Lamar Ave.  
Memphis, Tenn. 38118

**HOLLYBROOKE**  
See Laurie

**HOLLYWOOD**  
P.O. Box 115  
Madison, Tenn.

**HOLY CROSS**  
See McKinnon

**HOME OF THE BLUES**  
107 Beale St.  
Memphis, Tenn.

**HONOR BRIGADE**  
See SSS Int'l

**HOPE**  
See Image

**HORIZON**  
6290 Sunset Blvd.  
Hollywood, Calif.

**HOT BISCUIT**  
c/o Capitol

**HOT WAX**  
See Buddah

**HOURLY GLASS**  
2 E. 54th St.  
N.Y.C. 10022

**HOWARD**  
550 5th Ave.,  
N.Y.C.

**HUE**  
1705 W. 7th St.  
Ft. Worth, Texas 76102

**HUMCO**  
313 El Tejon Ave.  
Oildale, Calif.

**HUSH**  
P.O. Box 6174  
Albany, Calif. 94716

**IA**  
P.O. Box 14130  
5826 Brock St.  
Houston 77021

**IBC**  
147 Mulberry St.,  
N.Y.C.

**I.R.P.**  
19802 N. E. 12th Pl.  
N. Miami Beach, Fla.

**IDEAL**  
119 S. Sam Houston Blvd.  
San Benito, Texas

**IMPACT**  
See Heartwarming

**IMPALA**  
501 W. Shabonee Trail  
Mt. Prospect, Ill.

**IMPERIAL**  
1556 N. LaBrea  
N. Hollywood, Calif.

**IMMEDIATE**  
80 Central Pk. W.  
N.Y.C.

**IMPEX**  
6620 Kindred St.  
Philadelphia, Pa. 19149

**IMPULSE**  
See ABC

**IN-ARTS**  
971 No. LaCienega Blvd.  
Los Angeles, Calif. 90069

**INDEPENDENCE**  
8560 Sunset Blvd., Ste.  
702 Hollywood, Calif. 90069

**IN' SIGHT**  
2400 West Coast Hwy.  
Newport Beach, Calif.

**INSIGNIA**  
530 W. Main  
Hendersonville, Tenn.

**INSTANT**  
2401 Orleans Ave.  
New Orleans, La.

**INTEGRITY**  
3663 Daleford Rd.  
Cleveland, Ohio

**INTERNATIONAL ARTISTS**  
P.O. Box 14130  
Houston, Texas 77021

**INTRASTATE**  
P.O. Box 554  
Los Gatos, Calif.

**INTREPID**  
See Mercury

**INVICTUS**  
See Capitol

**ISLE CITY**  
P.O. Box 434  
Galveston Island, Texas 77550

**ITCO**  
1275 Bloomfield Ave.  
Fairfield, N. J. 07006

**IVANHOE**  
185 No. Wabash Ave.  
Chicago 60601

**JIB**  
P.O. Box 14422  
Tampa, Fla. 33609

**JAB**  
5019 S. Normandie  
Los Angeles, Calif.

**JAD**  
225 W. 57th St.  
New York 10019

**JAMAL**  
119 W. 57th St.  
NYC 10019

**JAMIE**  
919 N. Broad St.  
Philadelphia, Pa.

(Con't on next Page)

## The Millard Agency presents:

### SANTANA

"SANTANA played to an almost continuous standing ovation..."—Village Voice. (Columbia)

### Cold Blood

"One of rock music's most exciting onstage acts is Cold Blood. With blues-belter Lydia Pense as catalyst, Cold Blood grabs hold of an audience and works with it." (San Francisco/Antonic)

### It's A Beautiful Day

"David LaFlamme, the elegant and compelling violinist who heads It's A Beautiful Day, has rehearsed and drilled his sextet so that its musical foundation is as solid a structure as any among the San Francisco groups."—San Francisco Examiner. (Columbia)

### AUM

"Pure, lusty, hard-socking stuff... Aum leader Wayne 'The Harp' Ceballos is a heavy musician, a good singer and a fascinating showman."—San Francisco Examiner. (Fillmore/Columbia Records)

### Steve Baron Quartet

"Overflowing with melody, Steve's songs can touch inside every ear, rouse every heart to feeling."—Cash Box (Tetragrammaton)

### ELVIN BISHOP GROUP

"What Pete Seeger was to early '60's folk and what Donovan was to folk-rock, Elvin Bishop seems to be to revival blues."—Village Voice. (Fillmore/Columbia)

### CATFISH

"Catfish stole the show... Catfish is 250 lb. Bob Hodge... Catfish has showmanship... Catfish is a visual experience..."—Village Voice. (Epic)

### FAIRPORT CONVENTION

"With its exquisite voicings and sometimes gentle, sometimes rocking always imaginative and exciting instrumentation, Fairport Convention is an unqualified treasure."—Rolling Stone Magazine. (A&M)

### Louie Mack

"Is an incredible guitarist and a superb singer."—Rolling Stone.  
"A guitar virtuoso... One of the most accomplished guitarists you'll ever hear"—Jon Landau. (Elektra)

### MANFRED MANN CHAPTER THREE

"An optical illusion you listen to... Full blooded..." "A restrained menacing quality..." "Exotic incantation..." "Startling, surprising, moving..."—English music critics. (Polydor)

### REFUGEE

"Clapton, Beck and Page all capitalized on their Yardbirds reputation and formed their own bands. Each one, in turn, was heralded among 'those in the know' as THE English group... Keith Reif has finally come out with a group that equals, if not darn near surpasses, the potential of the aforementioned bands."—L.A. Free Press. (Elektra)

### RIG

"One of the most exciting new groups to come out of New York in years." (Capitol)

### The Sons (formerly THE SONS OF CHAMPLIN)

"One of the tightest, most together groups I've ever heard... one of the best purveyors of rock..."—Minneapolis Tribune. (Capitol)

HERB SPAR  
105 Second Avenue, New York, New York 10003  
(212) 677-8950



JOE BAILEY, Suite 3100  
555 California St., San Francisco, California 94104  
(415) 781-7566

# The Witch is a B....!



## “The Witch” by The Rattles

PROBE 480

SNOWBALLING ON THE FOLLOWING STATIONS:

WHOT-YOUNGSTOWN; WYSL-BUFFALO; WHMF, WBBF-ROCHESTER; WPRO-PROVIDENCE  
WPGC-WASH., D.C.; WCFL-CHICAGO; WOKY-MILWAUKEE; WIRL-PEORIA; WAIL-BATON  
ROUGE; WMC-FM-MEMPHIS; WORD-SPARTANBURG; WROU-ROANOKE; KLEO, KEYN-  
WICHITA; KIMN, KTLK, KLZ-FM-DENVER; KCBX, KNAK-SALT LAKE CITY; K TSA, KRIZ-  
PHOENIX; WLDF-ORLANDO; WGGG-GAINSVILLE; KCBQ-SAN DIEGO; KBZY-SALEM;  
KOL, KJR-SEATTLE; WKHX-SAGINAW; WILS-LANSING; WPAG-ANN ARBOR; WLAU-  
GRAND RAPIDS

# Record Manufacturers

**JAN MAR**  
344 W. Magnolia  
Glendale, Calif. 91204

**JANUS**  
1700 Broadway  
N.Y.C. 10019

**JAY-GEE**  
318 W. 48th St., N.Y.C.

**JAY-JAY**  
1959 71st St.  
Miami Beach, Fla. 33141

**JCD**  
2520 Jonesboro Rd.  
Atlanta, Ga. 30315

**JERDEN**  
971 Thomas St.  
Seattle, Wash. 98109

**JET SET**  
519 Davis Building  
Washington, D.C.

**JETSTAR**  
See Abnak

**JEWEL**  
728 Texas  
Shreveport, La. 71101

**JODY**  
See B-Atlas

**JOHNSON**  
1619 Broadway, N.Y.C. 10019

**JORDAY RECORDS**  
2227 Fifth Ave.  
Seattle, Wash.

**JOSIE**  
318 W. 48th St., N.Y.C.

**JUBILEE**  
1790 B'way, N.Y.C.

**JULMAR**  
1674 Broadway  
N.Y.C.

**KALEIDOSCOPE**  
See Epic

**KAM**  
1209 No. Alta Loma Rd.  
Hollywood 90069

**KAMA SUTRA**  
1650 B'way N.Y.C.

**KANGAROO**  
302 E. Dewey Ave  
San Gabriel, Calif. 91776

**KANWIC**  
1059 Porter  
Wichita, Kansas 67208

**KAPE**  
1491 E. 19th St.  
Brooklyn, N.Y. 11230

**KAPP**  
136 E. 57th St. N.Y.C.

**KARATE**  
See Audio Fidelity

**KAREN**  
See Atlantic

**KARMA, INC.**  
610 Stemmons Tower West  
Dallas, Texas 75207

**KAS-MO**  
6935 Airport Hwy. 1A  
Pennsauken, N.J.

**KARIE**  
See Shepard

**KASHE**  
1697 Broadway  
NYC. 10019

**KATHY**  
1500 Oreedmore Ave.  
Pittsburgh, Pa.

**KAYDEN**  
267 Haddon Ave.  
Collingsworth, N.J. 08108

**KAYSAL**  
1479 Cromwell Ave.  
Bronx, N.Y. 10452

**KEF**  
See Capitol

**KELIT-AURORA**  
241 W. 18 St.  
N.Y.C. 10011

**KENT**  
5810 So. Normandie  
Los Angeles, Calif. 90044

**KHOURY'S**  
Railroad & Bibao Sts.  
Lake Charles, La.

**KIM**  
254 E. 29th St.  
L.A. 90011

**KIMBERLY**  
5810 S. Mormandie  
Los Angeles, Calif.

**KIMLEY**  
See Circa

**KINETIC**  
See Columbia

**KING**  
1540 Brewster Ave  
Cincinnati 7, Ohio

**KIRSHNER**  
See RCA

**KISKI**  
Box 116  
North Apolla, Pa.

**KISMET**  
227 E. 14th St.  
N.Y.C. 10003

**KISS-KISS**  
261 Cumberland St.  
Brooklyn, N.Y.

**KITE**  
2520 Amarillo St.  
Baton Rouge, La. 70805

**KLONDIKE**  
See Holiday Inn

**KLUB**  
4 Column St.  
Greenville, S.C.

**KNIGHT**  
c/o Thunder  
P.O. Box 7724  
Independence, Mo. 64053

**KLUB**  
See Halo

**KOKO**  
See Stax

**KRASS**  
266 Reid Ave.  
Brooklyn, N.Y.

**LLP**  
345 W. 58th N.Y.C.

**LA COMEDIE FRANCAISE**  
See Everest

**LA LOUISIANNE**  
2823 Johnston St.  
Lafayette, La.

**LA SALLE**  
507 5th Ave  
N.Y.C. 10017

**LANCE**  
P.O. Box 8207  
Albuquerque, N.M. 87108

**LANDMARK**  
See Bell

**LANOR**  
P.O. Box 233  
Church Pt., La., 70525

**LANTAM**  
821 N. Broad St.  
Philadelphia, Pa.

**LAREDO**  
See Bandera

**LARGO**  
See CIRCA

**LAURIE**  
165 W. 46th St.  
N.Y.C. 10036

**LAVENDER**  
32nd & Jasper Rd.  
Springfield, Ore.

**LAVETTE**  
c/o Lincoln Prod.  
929 Larrabee  
L.A. 90069

**LAW U**  
6365 Selma Ave.  
Hollywood 90028

**LAWN**  
See Swan

**LE MONDE**  
See Le Grand

**LEADER**  
136 E. 57th St. N.Y.C.

**LECASVER**  
See Atlantic

**LECTRON**  
14460 Linnhurst  
Detroit, 48205

**LEGEND**  
143 W. 51st St.  
N.Y.C. 10019

**LEOPARD**  
2226 Carnes Ave  
Memphis, Tenn. 38114

**LHI**  
See Bell

**LIBERTY**  
6920 Sunset Blvd.  
Hollywood, Calif. 90028

**LIBRARY EDITIONS**  
See Request

**LIFE**  
See Earth

**LIMELIGHT**  
See Mercury

**LINDA**  
See Faro

**LINE 5**  
Box 3503  
Wilson, N.C.

**LION**  
See MGM

**LIONEL**  
1345 Ave-of-Americas  
N.Y.C. 10019

**LIQUID STEREO**  
5124 N.E. 34th Ave.  
Portland, Ore. 97211

**LITTLE DARLIN'**  
101 W. 55th St.  
N.Y.C. 10019

**LITTLE DAVID**  
200 W. 57 St.  
N.Y.C. 10019

**LITTLE SHIRLEY**  
See Mayhams

**LITTLE STAR**  
1600 N. La Brea  
Hollywood 28, Calif.

**LITTLE TOWN**  
Box 851  
Fall River, Mass.

**LITTLE WALT**  
85 Billings Ave.  
Medford, Mass. 02155

**LIVING LEGEND**  
6000 Sunset Blvd.  
Hollywood 28, Calif.

**LIVING LIBRARY**  
See Fuller

**LO "C"**  
See Aertaun

**LODESTAR**  
11225 Ewing Circle  
Minneapolis, Minn.

**LO-LO**  
See Calla

**LOMA**  
4000 Olive Ave.  
Burbank, Calif.

**LONDON**  
539 W. 25th St. N.Y.C.

**LONDON HOUSE**  
1064 Bergen St.  
Newark, N.J. 07112

**LONGHORN**  
2631 Fanville Dr.  
Dallas, Texas

**LUCKY**  
P.O. Box 14602  
Baton Rouge, La.

**LUCKY ELEVEN**  
1318 W. Court  
Flint, Mich.

**LYRIC**  
1747 N. 33rd St.  
Philadelphia, Pa.

**MB**  
8 E. 48th St.  
N.Y.C. 10017

**MGM**  
1350 Ave. of Americas, N.Y.C.

**MOC**  
See London

**MTA**  
40 West 55th St.  
New York, N.Y.

**MAGDA**  
2811 Guadalupe St.  
San Antonio, Texas 78207

**MAGIC CITY**  
8912 Grand River Ave.  
Detroit, Mich.

**MAHAKA**  
1006 Waimanu St.  
Honolulu, Hawaii 96814

**MAINLINE**  
1260 E. 38 St.  
Cleveland, Ohio 44114

**MAINSTREAM**  
1700 Broadway  
N.Y.C.

**MALA**  
See Amy

**MALTESE**  
P.O. Box 12281  
Norfolk, Va. 23502

**MAMA**  
13817 Benwood Rd.  
Cleveland, Ohio

**MANCO**  
P.O. Box 10188  
Ft. Worth, Tex.

**MAP CITY**  
236 W. 55th St.  
N.Y.C. 10019

**MARGIE**  
See McKinnon

**MARION**  
See McKinnon

**MARK II**  
5371 W. Pico Blvd.  
Los Angeles, Calif. 90019

**MARLO**  
Box 1122  
Port Jervis, N.Y.

**MARQUEE**  
c/o Tincal Music  
2051 Hyde Park Rd.  
Detroit, 48207

**MAR-VEL**  
See Glenn

**MAR-V-LUS**  
c/o One Der-Ful  
1829 S. Michigan Ave.  
Chicago, Ill.

**MAR-TONE**  
Box 247  
Harrodsburg, Ky.

**MASCOT**  
2945 W. Colter #7  
Phoenix, Ariz. 85015

**MASON**  
2716 Decatur  
Bronx, N.Y.

**MAST**  
See CIRCA

**MAVERICK**  
See Venture

**MAXWELL**  
See Crew

**MAYHAMS**  
12 West 117 St.  
N.Y.C.

**McHALL**  
6243 Fulcher Ave.  
No. Hollywood, 91606

**McKINNON**  
411 Gordon St.  
Reading, Pa. 19601

**MEDIARTS**  
9229 Sunset Blvd.  
Hollywood 90069

**MEGAPHONE**  
16661 Ventura Blvd.  
Encino, Calif. 91316

**MELARK**  
Box 138  
Heber Springs, Ark. 72543

**MENORAH**  
52 E. Broadway  
N.Y.C. 10022

**MERCURY**  
35 E. Wacker Dr.  
Chicago, Ill.

**METEOR**  
1794 Chelea Ave.  
Memphis, Tenn.

**METRO**  
See MGM

**METROBEAT**  
P.O. Box 775  
Minneapolis, Minn. 5540

**METROMEDIA**  
3 East 54th St.  
New York 10022

**MICHELLE**  
220 E. 26th St.  
N.Y.C.

(Con't on next Page)

## MASTERS NOW AVAILABLE

For Recording in the  
U. S. and Canada

Brazil's Most Wanted Music . . . . .!  
Brazil's Most Beloved Artists . . . . .!

ALBUMS and SINGLES  
on Brazil's Most Popular Labels



For sub-leasing rights call or write

D. Frenkiel, Mgr.

**FERMATA INTERNATIONAL  
MELODIES, Inc.**

6290 Sunset Blvd., Hollywood, Calif. 90028  
Phone: (213) 462-7473



**When they're not too busy doing other things, they listen to us.**  
...and they're not the only ones.

LIBERTY RECORDS/UNITED ARTISTS RECORDS/BLUE NOTE RECORDS/SUNSET RECORDS/TALESPINNER RECORDS/LIBERTY/UA STEREO TAPE

**Liberty/UA, Inc.**   
An Entertainment Service of  
Transamerica Corporation

# Record Manufacturers

**MOUNTAIN**  
P.O. Box 19337  
Denver 80219

**MU**  
P.O. Box 4122  
Charlotte, N.C. 28204

**MURBO**  
136 W. 52 St., N.Y.C.

**MUSART**  
16508 S. Main St.  
Gardena, Calif.

**MUSIC FACTORY**  
See MGM

**MUSIC GUILD**  
See ABC

**MUSIC LAND U.S.A.**  
9 Fawnridge Ct.  
St. Louis 41, Mo.

**MUSIC MINUS 1**  
43 W. 61st St., N.Y.C.

**MUSICOR**  
240 W. 55th St.  
New York, N.Y. 10019

**MUSIC ROW**  
See NRS

**MUSTANG**  
c/o Blue Star  
323 W. 14th St.  
Houston, 77008

**M/W**  
9360 Wilshire Blvd.  
Beverly Hills, Calif.

**NASHBORO**  
1011 Woodland St.  
Nashville, Tenn. 37206

**NASHVILLE**  
P.O. Box 115  
Madison, Tenn.

**NATIONAL**  
1123 N. Eutaw St.  
Baltimore 21201

**NAT'L GENERAL**  
See Buddha

**NEW RHYTHM**  
c/o Del Bruce  
P.O. Box 51902  
1874 Mirabeau Dr.  
New Orleans 70122

**NEW STAR**  
Goodlettsville, Tenn.

**NEWARK**  
88 St. Francis St.  
Newark, N.J.

**NEWTONE**  
1650 B'way N.Y.C. 10019

**NICO**  
6725 Sunset Blvd.  
Hollywood 90028

**NINA**  
604 8th Ave., N.Y.C.

**NOCTURNE**  
6232 Santa Monica Blvd.  
Hollywood, Calif. 90038

**NOLA**  
2117 Orleans Ave.  
New Orleans, La. 70117

**NONESUCH**  
See Elektra

**NORMAN**  
1900 Washington  
St. Louis, Mo.

**NOSLEN**  
4200 Mission Ave.  
E. St. Louis, Ill.

**NOTABLE**  
161 W. 54th St.  
N.Y.C.

**NRS**  
1703 Church St.  
Nashville 37202

**NUEVO**  
P.O. Box 734  
Mercedes, Texas 78570

**NUGGET**  
Route 1, Box 400  
Goodlettsville, Tenn. 37072

**NU-SOUND**  
P.O. Box 9429  
Rochester, N.Y. 14604

**O-R**  
Philadelphia 19132

**OCTAVE**  
520 5th Ave.  
N.Y.C.

**ODE '70**  
See A&M

**OHIO**  
P.O. Box 655  
Hudson, Ohio 44236

**OKEH**  
See Epic

**OLD TOWN**  
1697 Broadway, N.Y.C.

**OLYMPIA**  
See Jamie Guyden

**OMEGA**  
P.O. Box 558  
N. Hollywood, Calif.

**ONE-DERFUL**  
1829 S. Michigan Ave.  
Chicago, Ill.

**ORACLE**  
1051 Beacon St.  
Brookline, Mass.

**ORANGE GROVE**  
See McKinnon

**ORBIT**  
3809 Main St.  
Houston, Texas

**ORIGINAL SOUND**  
7120 Sunset Blvd.  
Hollywood, Calif. 90046

**ORPHEUM**  
235 W. 46 St.  
N.Y.C.

**OVATION**  
160 E. Grand Ave. e.  
Chicago 60611

**OWL**  
1229 University Ave.  
Boulder, Colo. 80302

**PKC**  
3240A North Bartlett Ave.  
Milwaukee, Wisc. 53211

**PACIFIC JAZZ**  
8715 W. 3rd  
Hollywood, Calif.

**PALETTE**  
250 W. 57th St.  
N.Y.C. 10019

**PALMER**  
13401 Lyndon Ave.  
Detroit, Mich.

**PAN**  
959 Main  
Buffalo, N.Y.

**PANTHER**  
See Southern Sounds

**PANTOMIME**  
P.O. Box 2902  
Phila, Pa. 19126

**PARAMOUNT**  
Sunset & Vine  
Hollywood 90028

**PARK AVE.**  
6201 Santa Monica Blvd.  
Hollywood, Calif.

**PARLIAMENT**  
See Arta

**PARLO**  
See Dover

**PARROT**  
See London

**PARNASO**  
275 South 2nd St.  
Brooklyn, N.Y.

**PARTHENON**  
815 16th Ave. So.  
Nashville, 37203

**PAT**  
1650 Broadway, N.Y.C.

**PAT MAK**  
320 W. 55 St.  
N.Y.C.

**PATTY**  
See Holton

**PAULA**  
728 Texas St.  
Shreveport, La.

**PAX**  
250 W. 57th St.  
N.Y.C. 10019

**PEACH**  
P.O. Box 147  
Louisville, Ga.

**PEACHTREE**  
See Mercury

**PEACOCK**  
2809 Erastus St.  
Houston, Texas

**PEARCE**  
16400 E. Truman Rd.  
Independence, Mo. 64050

**PEARLTONE**  
512 Columbus Ave.  
N.Y.C. 10024

**PENNANT**  
1207 Horn Ave.  
Hollywood, Calif.

**PENTAGRAM**  
See Jubilee

**PEOPLE**  
65 W. 55th St.  
N.Y.C. 10019  
6430 Sunset Blvd. Hollywood 90028

**PEPPER**  
P.O. Box 4006 Crosstown Sta.,  
47 So. Florence  
Memphis, Tenn. 38104

**PERCEPTION**  
165 W. 45th St.  
N.Y.C. 10036

**PERIOD**  
See Everest

**PERISCOPE**  
89 Hollingsworth St.  
Boston, Mass.

**PERRI**  
See Alacor

**PETAL**  
Drawer 90  
Southern Pines, N.C.

**PETE**  
8451 Melrose Ave.  
Hollywood 90069

**PETER PAN**  
See Ambassador

**PHI-DAN**  
See Phillies

**PHIL SPECTOR**  
See Phillies

**PHILIPS**  
35 E. Wacker Drive  
Chicago, Ill.

**PHIL-L.A. of Soul**  
See Jamie

**PHILLIPS INT.**  
639 Madison Ave.  
Memphis, Tenn.

**PHILLY GROOVE**  
See Bell

**PICKWICK**  
8-16 43rd Ave.  
L.I.C., N.Y. 11101

**PIECES OF EIGHT**  
3263 Oakdell Rd.  
North Hollywood, Calif.

**PIEDMONT**  
See McKinnon

**PIN POINT**  
1674 Broadway  
N.Y.C. 10019

**PIONEER**  
2050 Ludlow St.  
Phila., Pa.

**PIO NIYO**  
8619 Sunset Blvd.  
L.A., Calif. 90069

**PIT**  
5652 Daniels Ave.  
Dallas, Texas

**PITCH**  
See Gusman

**PLANTATION**  
See SSS Int'l

**PLA-ME**  
903 Louisiana  
Muskogee, Okla.

**PLATINUM**  
567 N.W. 27 St.  
Miami Beach, Fla. 33139

**PLATO**  
1028 Mason St.  
Milton, W. Va. 25541

**POLKATONE**  
See Jay-Jay

**POLYDOR**  
1700 Broadway  
New York, N.Y.

**POMPEII**  
3200 Lemmon Ave.  
Dallas 75204

**POPPY**  
See RCA

**POPSIDE**  
235 W. 46th St.  
N.Y.C. 10036

**PORT**  
See Jubilee

**POST**  
2201 Bryn Mawr Ave.  
Phila., Pa. 19131

**POW**  
200 W. 57th St., N.Y.C.

**POWERTREE**  
144 W. 57th, N.Y.C.

**PRaise**  
See Prism

**PRaise**  
Dept. C.  
Stoneboro, Pa. 16153

**PRESIDENT**  
135 W. 50th St.  
N.Y.C.

**PRESS**  
See London

**PRESTA**  
29 E. Monterey Way  
Phoenix, Ariz. 85012

**PRESTIGE**  
203 S. Washington Ave.  
Bergenfield, N.J.

**PRIDE**  
See People

**PRINCE**  
See Criterion

**PRISM**  
49 Heid Ave.  
Dayton, O.

**PROCLAIM**  
See NRS

**PROGRESSIVE SOUNDS OF AMERICA**  
7025 Clair Ave.  
Reseda, Calif. 91335

**PROMENADE**  
See Ambassador

**PUBLIC**  
6565 Sunset Blvd.  
Hollywood 90028

**PURE GOLD**  
c/o Fernwood  
297 N. Main St. Memphis

**PYRAMID**  
6417 W. 84th St.  
Los Angeles, Calif.

**PZAZZ**  
6725 Sunset Blvd.  
Hollywood 90028

**QUAD**  
See MGM

**QUALITY**  
380 Birchmont Rd.  
Toronto 13, Ont., Cana.

**QUEEN**  
See King

(Con't on next Page)

**MICKEY**  
26 Mountain Ave.  
Dover, N.J. 07801

**MID-SOUTH**  
See Fernwood

**MIDNIGHT**  
See Aravel

**MIJJI**  
272 Old Adobe Rd.  
Los Gatos, Calif.

**MIKE**  
c/o Apco  
1902 Gregg Rd.  
Bellevue, Neb. 68000

**MILESTONE**  
See CIRCA

**MINARET**  
See SSS Int'l

**MINIT**  
See Liberty

**MINUTEMAN**  
c/o Columbus  
30 Nashua St.  
Woburn, Mass. 01801

**MIO INT'L**  
185 West End Ave.  
N.Y.C. 10023

**MIRA**  
9145 Sunset Blvd.  
Los Angeles, Calif.

**MISTER MAESTRO**  
7 Central Park West  
N.Y.C.

**MISTY**  
4327 Spellman  
Houston, Texas 77035

**MIZON**  
See Dock Mack

**MOBIE**  
P.O. Box 4902  
Chicago, Ill. 60680

**MOBILE FIDELITY**  
Box 336  
Burbank, Calif.

**MODE**  
c/o Del Bruce  
P.O. Box 51902  
1874 Mirabeau Dr.  
New Orleans 70122

**MODERN**  
9317 W. Wash. Blvd.  
Culver City, Calif.

**MOHAWK**  
Box 235, Rte 1  
Laurens, S.C. 29360

**MONARCH**  
4852 W. Jefferson  
Los Angeles, Calif.

**MONEY**  
1065 E. Vernon Ave.  
Los Angeles, Calif.

**MONITOR**  
156 5th Ave.  
N.Y.C. 10010

**MONITOR**  
1916 Fairbanks Rd.,  
Balto, Md.

**MONMOUTH-  
EVERGREEN**  
157 W. 57th St. N.Y.C.

**MONUMENT**  
530 W. Main St.  
Hendersonville, Tenn.

**MONUMENTAL**  
See Bat

**MOODSVILLE**  
See Prestige

**MOONGLOW**  
23007 Ventura Blvd.  
Woodland Hills, Calif. 91364

**MORE SOUL**  
746 E. 75th St.  
Chicago, Ill.

**MOSAIC**  
P.O. Box 1224  
Studio City, Calif. 91604

**MOTHER LODE**  
550 Fifth Ave., N.Y.C.

**MOTHERS**  
8218 Sunset Blvd.  
Hollywood 90046

**MOTOWN**  
2457 Woodward Ave.  
Detroit, Mich. 48201



# THE MEMPHIS SOUND

..where everything is everything.

tax, deep in the fertile soil of the southern United States as cultivated and nurtured an energy that has its roots firmly planted in America and its branches spreading the continents of the world.

The Memphis Sound: Soul Music, an energy with a message that has no regard for political preference, ethnic background or ideologies. Check it out... It's the real thing from Memphis U.S.A.

**TAX SOUL SOURCE:** Bar Kays/ J. J. Barnes/ William Bell/ Booker T and the MGs/ Chuck Boris/ Chuck Brooks/ The Caboose/ Steve Cropper/ Dallas County/ Billy Eckstine/ The Emotions/ Eddie Floyd/ Bernie Hayes/ Isaac Hayes/ Jimmy Hughes/ Luther Ingram/ Reverend Jesse Jackson/ Margie Joseph/ John KaSandra/ Albert King/ Barbara Lewis/ Little Sonny/ The Mad Lads/ Art Jerry Miller/ Moloch/ The Newcomers/ Ollie and the Nightingales/ Paris Pilot/ David Porter/ Roz Ryan/ The Soul Children/ Southwest F.O.B./ The Staple Singers/ Mavis Staples/ Clark Sullivan/ Johnnie Taylor/ Carla Thomas/ Rufus Thomas/ Reverend Maceo Woods



Enterprise Records, Volt Records and Respect Records are divisions of Stax Records, a division of Famous Music Corporation, A G+W Company. STAX RECORDS, 98 North Avalon, Memphis, Tennessee 38104 \*AVAILABLE ON 8-TRACK CARTRIDGE AND CASSETTES

# Record Manufacturers

**QUICK**  
364 N. Madison  
Pasadena, Calif.

**RCA**  
1133 Ave of the Americas  
New York 10036

**RCI**  
4 William St.  
Elmsford, N.Y. 10523

**R.I.C.**  
6422 20th Ave.  
Brooklyn, N.Y. 11234

**RMR**  
P.O. Box 82  
Cheyenne, Wyo. 82001

**RMS**  
4327 So. Sacramento Ave.  
Chicago, Ill. 60632

**R'NB**  
See Guilford

**RODG**  
c/o A & L  
1819 Fairmount  
Philadelphia, Pa.

**RPM**  
9317 W. Wash. Blvd.  
Culver City, Calif.

**RPR**  
6404 Hollywood Blvd.  
Hollywood, 90028

**R.R.C.**  
See Recordland

**RSVP**  
1650 Broadwav, N.Y.C.

**RAE-COX**  
1674 Broadway  
N.Y.C. 10019

**RAFTIS**  
850 7th Ave.  
N.Y.C. 10019

**RAIN**  
See Bell

**RAINY DAY**  
See Jay-Gee

**RALLY**  
c/o Ralph's Radio Music  
P.O. Box 127  
Demorest, Ga.

**RAMA RAMA**  
8733 Sunset Blvd.  
L.A. 90069

**RAMCO**  
3830 N. 7th St.  
Phoenix, Ariz.

**RAMPART**  
5004 Melrose Ave.  
Hollywood, Calif.

**RAMS'L**  
30 No. Lasalle St.  
Chicago 60604

**RANWOOD**  
9034 Sunset Blvd.  
Los Angeles, Calif.

**RARE EARTH**  
See Motown

**RAVEN**  
P.O. Box 20037  
Sacramento, Calif. 95820

**READING**  
See McKinnon

**RE-CAR**  
2948 1st Ave. S.  
Minneapolis 8, Minn.

**RECITAL HALL**  
See Connoisseur

**RECORD DISTRIBUTORS  
OF AMERICA**  
780 W. 27th St.  
Hialeah, Fla.

**REDHILL**  
Box 541  
La Mirada, Calif. 90638

**RED LION**  
200 W. 57th St.  
N.Y.C. 10019

**REFLECTION**  
182-41 89th Ave.  
Holllis, L.I. N.Y.

**REGAL**  
7816 N. Interstate Ave.  
Portland, Ore. 97217

**REGALIA**  
P.O. Box 3  
Brooklyn, N.Y. 11229

**REGENCY**  
P.O. Box 558  
Hollywood, Calif. 91603

**REGENT**  
See Savoy

**REGGAE**  
See Flying Dutchman

**REPUBLIC**  
5939 Sunset Blvd.  
Hollywood 90028

**REQUEST**  
66 Mechanic St.  
New Rochelle, N.Y.

**RESPECT**  
See Stax

**REMEMBER**  
8733 Sunset Blvd.  
L.A. 90069

**RENAISSANCE**  
See Everest

**RENDEZVOUS**  
6367 Selma Ave.  
Hollywood, Calif.

**RENEGADE**  
See White Whale

**RENOWN**  
215 Johnston St.  
Smithfield, N.C. 27577

**REPEAT**  
5782 E. 2nd St.  
Long Beach, Calif.

**REPRISE**  
See Warner Bros.

**REPUBLIC**  
3830 N. 7th St.  
Phoenix, Ariz.

**REVEILLE**  
P.O.Box 669  
Hollywood, Calif.

**REVUE**  
See Uni

**REXFORD**  
6223 Selma Ave.  
Hollywood, Calif.

**RIC**  
801 16 Ave. So.  
Nashville, Tenn.

**RIC TIC**  
2307 Edison  
Detroit, Mich.

**RICHMOND**  
539 W. 25th St., N.Y.C.

**RIDGEWAY**  
6087 Sunset Blvd.  
Hollywood, Calif.

**RING-A-DING**  
8425 Melrose  
Hollywood, Calif.

**RIPARIA D'ORO**  
475 5th Ave.  
N.Y.C. 10017

**RIPCORD**  
4009 E. 18th St.  
P.O. Box 2098  
Vancouver, Wash. 98661

**RISING SONS**  
See Monument

**RIVERSIDE**  
235 W. 46th St.,  
N.Y.C. 10036

**RIVIERA**  
See U.S.A.

**RIVIERA**  
1609 Hawkins St.  
Nashville, Tenn. 37203

**RMT**  
1528-30 Overington St.  
Philadelphia, Pa.

**ROAD**  
411 Gordon St.  
Reading, Pa.

**ROBERE**  
195 First St.  
Newark, N.J.

**ROCK-IT**  
598 W. Edgemont Dr.  
San Bernadino,  
Calif. 92405

**ROCKLAND**  
43 W. 61st. ST.  
N.Y.C. 10023

**ROD**  
6 Morningside Rd.  
Colonia, N.J. 07067

**ROGERS**  
P.O. Box 552  
Dana Pt., Calif. 92405

**RO-JAC**  
427 Laurens St.  
Baltimore, Md.

**ROMUR**  
431 S. 62nd St.  
Phila., Pa. 19143

**RONN**  
P.O. Box 14602  
Baton Rouge, La.

**ROULETTE**  
17 W. 60th St.  
New York 10019

**ROYAL**  
2828 Midvale Ave.  
L.A. Calif. 90064

**ROYAL AMERICAN**  
See Buddha

**ROYAL STANDARD**  
1674 Broadway  
N.Y.C.

**RU-JAC**  
See Jamie

**RUMAC**  
P.O. Box 2067 D  
Pasadena, Calif.

**RUST**  
See Laurie

**S & G**  
403 So. Adams St.  
Peoria, Ill. 61602

**S&R**  
16508 So. Main St.  
Gardena, Calif.

**SCI**  
333 W. 9th St.  
Indianapolis 46202

**SGC**  
See Atco

**SJR**  
P.O. Box 181  
Bellevue, Ohio 44811

**SSS INT'L**  
3106 Belmont Blvd.  
Nashville, Tenn. 37212

**SACK**  
See Canyon

**SAGE AND SAND**  
5653 1/2 Hollywood Blvd.  
Hollywood 28, Calif.

**SALEM**  
111 Main St.  
Salem, Va.

**SAMTER**  
522 Lafayette St.  
Gretna, La.

**SAN FRANCISCO**  
See Atlantic

**SAND**  
6520 Selma Ave.  
Hollywood, 90028

**SAN-DEE**  
212 N. 12th St.  
Philadelphia, Pa.

**SANDY**  
P.O. Box 248  
Mobile, Ala.

**SANSU**  
See Deesu

**SARU**  
2300 Payne Ave.  
Cleveland 44114

**SCALA**  
See Everest

**SCARLET**  
See Commonwealth United

**SCEPTER**  
254 W. 54th St. N.Y.C.

**SCOPE**  
2635 W. Grand Blvd.  
Detroit, Mich. 48208

**SEECO**  
39 W. 60th St., N.Y.C.

**SELECT**  
See Joy

**SENTAR**  
See Cameo

**SEVEN B**  
715 Camp St.  
New Orleans, La. 70130

**SEVILLE**  
See London

**SEW CITY**  
850 7th Ave., N.Y.C.

(Con't on next Pa

# ALSHIRE INTERNATIONAL

## THE WORLD'S GREATEST ENTERTAINMENT VALUE

AL SHERMAN, PRESIDENT



Cable Address — 'BUDSOUND'

PHONE 213-849-4671

222 West Orange Grove Ave. — Burbank, California 91505

**HEAR  
AND  
NOW**

  
**polydor**

  
**FOR** 

POLYDOR INC., 1700 Broadway, New York, New York Tel. (212) 245-0600

# Record Manufacturers

**SHALIMAR**  
1314-24 S. Howard  
Philadelphia, Pa.

**SHAMLEY**  
See Uni

**SHAMROCK**  
1310 S. New Hampshire  
Los Angeles, Calif.

**SHAR-DEE**  
c/o Hansen  
1842 West Ave  
Miami Beach, Fla.

**SHARON**  
Box 2343  
Hollywood, Calif.

**SHASTA**  
4720 Forman Ave.  
Hollywood 8, Calif.

**SHELTER**  
See Blue Thumb

**SHIRLEY**  
43465 Sweetwood St.  
Fremont, Calif.

**SHOMAR**  
2306 Louisiana  
Houston, Texas

**SHOUT**  
See Bang

**SHOW BOAT**  
c/o Top Talent  
1121 South Glenstone Ave.  
Springfield, Mo.

**SHREVE**  
P.O. Box 1063  
Shreveport, La.

**SHUR-TINGA**  
254 E. 29th St.  
L.A. 90011

**SIDEWALK**  
See Tower

**SIDRA**  
See Drew

**SIERRA**  
1680 Vine St.  
Hollywood 90028

**SIGNET**  
See CIRCA

**SILVER CLOUD**  
1800 Highland  
Hollywood, Calif.

**SILVER CROSS**  
See Bluestown

**SILVER DOLLAR**  
1289 Haynes No. 8  
Memphis, Tenn. 38114

**SILVER FOX**  
See SSS Int'l

**SIMON SAYS**  
See ABC

**SIMS**  
801 17th Ave., S.  
Nashville, Tenn.

**SIRE**  
146 W. 54th St.  
N.Y.C. 10019

**SKYE**  
40 W. 55 St.  
N.Y.C. 10019

**SKYLAR**  
See Era

**SKYLARK**  
5109 1/2 Hollywood Blvd.  
Los Angeles, Calif.

**SKYLITE**  
133 S. Atlantic Blvd.  
Compton, Calif.

**SKYROCKET**  
1739 N. 3rd St.  
Philadelphia, Pa.

**SKYSCRAPER**  
See Holton

**SKYWAY**  
Box 133  
Hollywood, Calif.

**SLEEPER**  
Box 662  
Meridan, Miss.

**SLIDE**  
See McKinnon

**SMART**  
P.O. Box 31183  
Birmingham 35222

**SMART**  
P.O. Box 31183  
Birmingham 35222

**SMOBRO**  
See Buddah

**SMOKE**  
310 Chadwick Ave.  
Newark, N.J. 07112

**SNAP**  
1125 Bryan St.  
South Bend, Ind. 46616

**S.O.C.**  
See Request

**SOCK IT**  
2110 Bath Ave  
Brooklyn, N.Y.

**SODESKA**  
177 Beach 141st St.  
Belle Harbor, L.I., N.Y.

**SOLAR**  
818 6th St.  
Union Beach, N.J. 07735

**SOLID GOLD**  
713 18th Ave. S.  
Nashville, Tenn.

**SOLID SOUL**  
1812 Constantinople St.  
New Orleans, La. 70115

**SOMA**  
7600 Wayzata Blvd.  
Minneapolis, Minn.

**SOMERSET**  
See Miller Int'l

**SONOBEAT**  
P.O. Box 4038  
Austin, Texas 78751

**SOUL**  
See Tamla

**SOUL CITY**  
1560 N. La Brea  
Hollywood, Calif.

**SOUL CLOCK**  
See Fantasy

**SOUL SOUND**  
1812 Constantinople St.  
New Orleans, La. 70115

**SOUL TRAIN**  
10075 C. Windstream Dr.  
Columbia, Md. 21043

**SOULIN'**  
1812 Constantinople St.  
New Orleans, La. 70115

**SOULVILLE**  
2308-10 North 6th St.  
Harrisburg, Pa. 17102

**SOUND OF SOUL**  
See Golden Triangle

**SOUND STAGE-7**  
See Monument

**SOUTHERN SOUNDS**  
918-3rd Ave. N.W.  
Hickory, N.C. 28601

**SOUTHLAND**  
520 St. Louis St.  
New Orleans, La.

**SOUTH-TOWN**  
711 W. 60th St.  
Chicago, 60621

**SPACE**  
2037 Alvarado Dr. N.E.  
Albuquerque, N.M. 87110

**SPAR**  
P.O. Box 7663  
Nashville, Tenn.

**SPECIALTY**  
8300 Santa Monica Blvd.  
Hollywood, Calif.

**SPEED**  
345 W. 58th St. N.Y.C.

**SPINIT**  
Galveston, Texas

**SPINNING**  
510 N. Dearborn St.  
Chicago, Ill.

**SPIRAL**  
875 5th Ave., N.Y.C.

**SPIRIT**  
See Guilford

**SPONTANEOUS ARTS**  
1650 Broadway  
NYC 10019

**SPOT**  
1053 Lynn Garden Dr.  
Kingsport, Tenn.

**SPOTLITE**  
2 Geary St.  
San Francisco, Calif.

**SPRING**  
See Polydor

**SPRINGBOARD**  
110 Bergen Pike  
Little Ferry, N.J.

**STADIUM**  
Box 38631  
Hollywood, Calif.

**STAGG**  
No. 10 Marlo Dr.  
Belleville, Ill.

**STANG**  
See All-Platinum

**STANYON**  
8721 Sunset Blvd.  
Hollywood

**STAR DISCOS**  
100-102 Texas Ave.  
El Paso, Texas

**STARDAY**  
P.O. Box 115  
Madison, Tenn. 37115

**STARTIME**  
See Abnak

**STAX**  
926 E. McLemore  
Memphis, Tenn.

**STEADY**  
846 7th Ave.  
NYC 10019

**STEED**  
See Dot

**STELLAR**  
550 5th Ave. N.Y.C.

**STEPHENY**  
510 N. Dearborn St.  
Chicago, Ill.

**STEREO DIMENSION**  
118 W. 57th St.  
New York 10019

**STEREOODDITIES**  
259 S.W. Terrace  
Ft. Lauderdale, Fla.

**STONE FLOWER**  
See Atlantic

**STONEWAY**  
2817 Laura Koppe  
Houston 77016

**STOP**  
809 18th Ave.  
Nashville, Tenn. 37203

**STRAIGHT**  
5455 Wilshire Blvd.  
L.A. 90036

**STROBE**  
1650 Broadway  
N.Y.C. 10019

**STYLE**  
c/o World Wide  
1674 Broadway, N.Y.C.

**STYLETONE**  
254 E. 29th St.  
L.A. 90011

**SUE**  
265 W. 54th St.  
New York, N.Y.

**SULTAN**  
245 E. 30th St.  
N.Y.C. 10016

**SUMMIT**  
1158 Skipper Dr.  
Mobile, Ala.

**SUMPTER**  
See SSS Int'l

**SUN**  
See SSS Int'l.

**SUNDOWN**  
See White Whale

**SUN-RAY**  
1162 Wyatt Pkwy.  
Lexington, Ky. 40505

**SUPER K**  
See Buddah

**SUPREME**  
See Detroit

**SURE**  
Box 94  
Broom Hall, Pa.

**SURE-FIRE**  
319 Seventh Ave., N.  
Nashville, Tenn.

**SURE-SHOT**  
See Duke

**SURFSIDE**  
2805 Biscayne Blvd.  
Miami 37, Fla.

**SURPRISE**  
167-24 Foch Blvd.  
Jamaica, N.Y. 11434

**SUSSEX**  
See Buddah

**SYLVANIA  
SYMCA**  
825 Madison Ave.  
N.Y.C. 10021

**SWINGIN'**  
See CIRCA

**SYMBOL**  
See Sup

**T-A**  
See Bell

**T&G**  
5731 Acme Ave.  
St. Louis, Mo.

**T-NECK**  
See Buddah

**TNT**  
1422 W. Poplar  
San Antonio, Texas

**TAB**  
1121 Market  
Galveston, Texas

**TAHITI**  
See Criterion

**TAKE 6**  
6565 Sunset Blvd., Suite 210  
Hollywood, Calif. 90028

**TALLY**  
Box 842  
Bakersfield, Calif.

**TALOS II**  
P.O. Box 469  
Tifton, Ga. 31794

**TALUN STEREO**  
P.O. Box 1025  
Indianapolis, Ind. 46206

**TAMBOURINE**  
See Monument

**TAMLA**  
2457 Woodward Ave.  
Detroit, Mich.

**TAMMY**  
708 Fifth St.  
Struthers, O.

**TANGERINE**  
See ABC

**TAPE**  
See CIRCA

**TARGET**  
315 S. Bluemound Dr.  
Appleton, Wisc. 54911

**TAURUS**  
6510 St. Clair  
Cleveland, Ohio

**TEAM**  
See Buddah

**TEEN TOWN**  
P.O. Box 66  
Thiensville, Wisc. 53092

**TEMPE**  
6365 Selma Ave.  
Hollywood 28, Calif.

**TEMPLE**  
2080 Delaware  
Detroit, Mich.

**TETRAGRAMMATON**  
359 No. Canon Dr.  
Beverly Hills, Calif. 90210

**TEXAN**  
Box 935  
Irving, Texas

**THELAMA**  
1457 National Ave.  
Memphis, Tenn. 38122

**THOMAS**  
See Buddah

**THOR**  
399 Fullerton Pkwy.  
Chicago, Ill.

**3 H's**  
3333 San Marino St.  
Los Angeles, Calif. 90006

**3 SONS**  
928 Western Savings Fund Bld  
Philadelphia, Pa.

**THRESHOLD**  
See London

**THUNDER**  
5825 So. Morris Blvd.  
Tucson, Ariz.

**THUNDERBIRD**  
c/o Masters Releasing  
1790 Main St.  
Buffalo 19

**TIARA**  
835 Hamilton Ave.  
Fort Wayne, Ind.

**TICO**  
See Roulette

**TIDE**  
2146 W. View St.  
Los Angeles 16, Calif.

**TIFFANY**  
See Scepter

**TIFTON**  
c/o Ambassador

**TIGER**  
See Red Bird

(Con't on next Page)

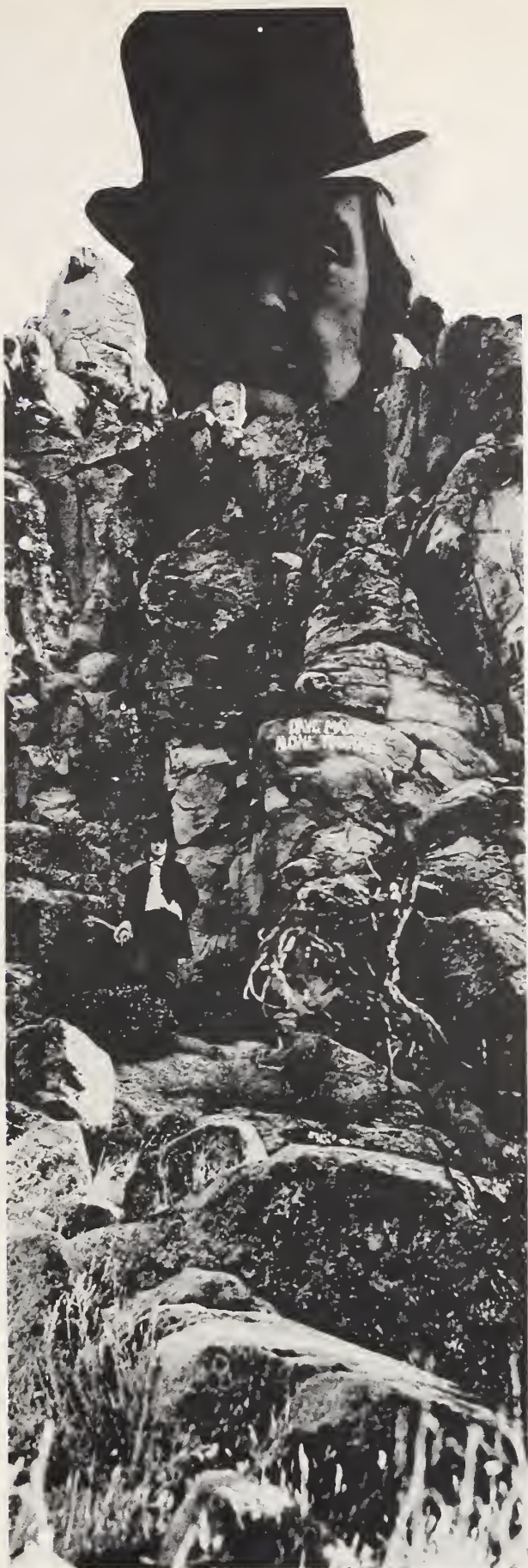

PRODUCED BY TOMMY LI PUMA AND DAVE MASON

<b>SIDE 1</b>		<b>SIDE 2</b>	
1 ONLY YOU KNOW AND I KNOW	4:58	1 WE'RE IN CHANCES	3:00
2 CAN I STOP WALKING	3:02	2 SAND AND DIRT AS WE GO	3:01
3 I WANT TO STOP	3:02	3 JUST A LITTLE	3:00
4 WALKING ON ME	3:02	4 EVERYBODY'S GONNA SAY	3:00
5 WALKING I HAVE TO BE MORE	3:02	5 I'M NOT A STAR	3:00
6 I'M NOT A STAR	3:02		

© 1970 Blue Thumb Records, Inc. All Rights Reserved. Printed in U.S.A.

# Have Your Own Dave Mason Hangup

Dave Mason *Alone Together* on Blue Thumb Records. A great new album — a great new packaging concept. The Kangaropac, a fold-out package which becomes a die-cut poster and in-store display piece features a colored vinyl record. Exciting musically and visually. See it — hear it — hang it. *Alone Together* on Blue Thumb Records and Tapes.



Kangaropac Patent Pending.  
© 1970 Camouflage Productions  
All Rights Reserved.

blueprint foam



cyclone

bell



AMOS



# an independent record company



D HILLY GROOVE



SHOW  
BIZ



## PRODUCERS

DON ALTFELD & MICKEY SHAPIRO  
H. B. BARNUM  
MIKE BERNIKER  
HERB BERNSTEIN  
STEVE BINDER  
CHUCK BLORE & DON RICHMAN  
JIMMY BOWEN  
TOMMY COGBILL  
MAC DAVIS  
ROGER EASTERBY & DES CHAMP  
WES FARRELL  
MARC GORDON  
ELLIE GREENWICH & MIKE RASHKOW  
LEE HAZELWOOD  
BONES HOWE  
MIKE HURST  
STEPHEN JAMES  
BILL JUSTIS  
MEL KLEIN  
DENNIS LAMBERT & BRIAN POTTER  
TONY MACAULAY  
GEORGE MARTIN  
BILL MEDLEY  
HANK MEDRAS  
BOB MERSEY  
CHIPS MOMAN  
RICHARD MOORE  
FELIX PAPPALARDI  
STEVE ROWLAND  
BOBBY RUSSELL & BUZZ CASON  
ROGER SOVINE  
MIKE STOLLER  
SHEL TALMY  
TOM THACKER  
PHIL WALLER  
STAN WATSON & THOM BELL

Listed Alphabetically



# ONE STOPS

## ALABAMA

Virgil Lugar  
Music Center  
416 North 19th Street  
Birmingham, Ala. 35203

Variety Record Service  
1028 North First Ave.  
Birmingham, Ala. 35203

Victory Records  
1028 North First Avenue  
Birmingham, Ala. 35203

The Record Shop Annex  
11A Parkway City  
Huntsville, Ala.

Dixie Supermarket Service  
P. O. Box 1192  
Mobile, Ala. 36601

Mr. Parks  
Music City Record Service  
4008 Dauphin Island Parkway  
Mobile, Ala. 36605

Prichard Music & Appl.  
112 Main Street  
Prichard, Ala. 36612

## ARIZONA

ARC  
2029 North Black Canyon Hwy.  
Phoenix, Ariz. 85324

Joe English  
Flash Dist.  
3907 E. Yale  
Phoenix, Ariz. 85005

## ARKANSAS

Jim Moses  
Moses Melody  
505 Main Street  
Little Rock, Ark. 72201

David Seibert  
Seiberts News Agency  
6301 Forbing Road  
Little Rock, Ark. 72204

## CALIFORNIA

Hal Furtney  
Pic-A-Tune  
1461 Park Ave.  
Emeryville, Calif. 94608

Flo Bigelow  
Pic-A-Tune  
1461 Park Ave.  
Emeryville, Calif. 94608

Western  
1461 Park Ave.  
Emeryville, Calif. 94608

Jerry Barish  
California Music  
2933 W. Pico Blvd.  
Los Angeles, Calif. 90006

Martin Shaw  
Dale Record Service  
5873 Rodeo Road  
Los Angeles, Calif. 90016

Disc Mobile  
2567 W. Pico Blvd.  
Los Angeles, Calif. 90052

Luenhagens  
2277 W. Pico Blvd.  
Los Angeles, Calif. 90006

Rick Susser  
New Deal  
3660 W. Pico Blvd.  
Los Angeles, Calif. 90052

Norton Beckman  
Norty's  
436 N. Fairfax Ave.  
Los Angeles, Calif. 90036

Op's One Stop  
2647 W. Pico Blvd.  
Los Angeles, Calif. 90006

Al LaTosca  
Sunstate  
2669 W. Pico Blvd.  
Los Angeles, Calif. 90006

Sam Ricklin  
California Music  
2933 W. Pico Blvd.  
Los Angeles, Calif. 90006

Joel Miller  
West Coast Music Sales  
2833 W. Pico Blvd.  
Los Angeles, Calif. 90006

Vogue Rec. Dist.  
2818 West Pico Blvd.  
Los Angeles, Calif. 90006

Carl Schumaker  
M.T.S. Inc.  
1518 Broadway  
Sacramento, Calif. 95818

Harvey Braviroff  
Braviroff Piano & Music  
1170 E. Street  
San Bernardino, Calif. 94202

Dial Sales  
1835 Fifth Ave.  
San Diego, Calif. 92101

Frank Metzker  
Hit Line Record Sales  
P. O. Box 15293  
San Diego, Calif. 92115

Ratner Electric  
745 Broadway  
San Diego, Calif. 92101

Don Ayres  
Basford One Stop  
Box 3980  
San Francisco, Calif. 94119

Godfrey Dickey  
Nor-Cal  
1175 Howard Street  
San Francisco, Calif. 94103

Leon Bohem  
Pic-A-Tune  
645 Bryant  
San Francisco, California 94107

Western  
645 Bryant St.  
San Francisco, Calif. 94107

Art Walker  
Discorama  
235 South First St.  
San Jose, Calif. 95113

Godfrey Dickey  
Nor-Cal One Stop  
233 Utah Ave.  
South San Francisco, Calif.

## CANADA

J. R. Johnson  
Southern Music Ltd.  
1025 11th Avenue, S.W.  
Calgary, Alberta, Canada

## COLORADO

James Scott, Sr.  
A & N  
P. O. Box 2671  
Denver, Colo. 80201

Mountain Distributors  
3630 Downing St.  
Denver, Colo. 80205

Bob Baker  
One Stop Record Dist.  
6265 E. Evans  
Denver, Colo. 80222

Pat Fitzgerald  
Mershaw Midwest  
3990 Grape  
Denver, Colo. 80207

Bob Krug  
Mile High One Stop  
77 Kalamuth  
Denver, Colorado 80223

Vivian Ludi  
Mountain Distributors  
3630 Downing  
Denver, Colo. 80205

Paul Marcu  
Musit Merchandisers  
3825 Newport Street  
Denver, Colo. 80207

Manny Martinéz  
Mile High One Stop  
77 Kalamuth  
Denver, Colo. 80223

## CONNECTICUT

John Roccanella  
Central  
477 Park Ave.  
E. Hartford, Conn. 06108

Dave Bratter  
Dave's One Stop, Inc.  
171 Park Ave.  
E. Hartford, Conn. 06108

Eastern One-Stop  
734 Tolland St.  
E. Hartford, Conn. 06108

Gene Gotthelf  
Globe One-Stop  
308 Tolland St.  
E. Hartford, Conn. 06108

Ed Stein  
Leslie Dist. N.E.  
275 Park Ave.  
E. Hartford, Conn. 06108

Cutler's  
33 Broadway  
New Haven, Conn. 06511

New Deal One Stop  
215 Lamberton St.  
New Haven, Conn. 06510

## DISTRICT OF COLUMBIA

John Kmiec  
Potomac Music Service  
3746 N.E. 10th St.  
Washington, D.C. 20017

Mike Mackvlics  
Potomac Music Service  
3746 N.E. 10th St.  
Washington, D.C. 20017

Max Silverman  
Quality Music  
1836 7th St. N.W.  
Washington, D.C. 20001

Milt Swiller  
Record City  
700 13th St. N.W.  
Washington, D.C. 20005

(Con't. on next page)

### WE CARRY THE COMPLETE LINES OF SINGLES AND LP'S

To Offer Greater Service and Selection  
to our Music Operator Friends

### LORMAR SHIPS RECORDS ANYWHERE IN THE USA

Our New Location is at

## LORMAR Record Dist. Co.

2311 N. Western Ave., Chicago, Ill. 60647

Phones: BR. 8-8300

### A COMPLETE SERVICE for your

## ONE-STOP

- ☆ Regular Title Strips
- ☆ "Color-Lite" Title Strips
- ☆ "Photo-Lite" Title Strips

Plus All Styles and Colors of Blanks, Colored Acetates . . .  
Commercial Printing. Samples Sent On Request.

☆☆☆

### STAR TITLE STRIP COMPANY, INC.

842 WESTERN AVENUE Area Code 412 231-4314 PITTSBURGH, PA. 15233



# When people go around saying "we're number one" consider the source.

We go around saying it all the time. When you consider the source (or the sources) that we go to for Ampex music . . . it figures we'd be Number One.

In less than 4 years Ampex has become one of the largest complexes in the entertainment field. We're in stereo tape, in records, in independent musical production, and we're on the Broadway stage. Ampex produces music, reproduces it, bankrolls it, distributes it, promotes it, advertises it, and does more than anyone else to guarantee that artists, producers, distributors, dealers . . . and the public . . . get more of the best than anyone else can deliver.

Consider our sources: Ampex Stereo Tapes features over 70 different recording company labels. That's why more than 7000 selections by over 650 artists are sold on Ampex Stereo Tapes . . . rock, soul, pop, jazz, folk, classical and the spoken word on 4-track cartridge, 8-track cartridge, open reel, cassette and micro-cassette.

And Ampex Stereo Tapes has its own line-up of producers . . . talented giants of the music business . . . still another source providing a wealth of solid, in-demand albums that sell week after week, month after month.

Our sources include the Broadway stage. When they decided to produce "Purlie" Ampex was one of the original backers. Now the Number One name in home entertainment owns part of the award-winning Number One musical on Broadway. . . and the music rights to the original cast recording. "Purlie" is a box office winner . . . "Purlie" LP and stereo tape albums are winners in stores from coast to coast.

Our sources include the vast pool of new talent on its way up and established stars who recognize the potential that a new, aggressive, wholly contemporary entertainment complex offers.

Ampex goes to more sources than anyone in the entertainment field to make Ampex music the most profitable you can sell. That's why we can go around saying "We're Number One".

If you're not selling Ampex music, contact your Ampex Stereo Tapes distributor and your Ampex Records distributor. **CONSIDER THE SOURCE!!**

**AMPEX**  
RECORDS

**AMPEX**  
STEREO TAPES

Ampex Stereo Tapes Division • Ampex Corporation/2201 Lunt Avenue • Elk Grove Village, Ill. 60007

MARKETING OFFICE: 555 Madison Avenue, New York, New York. SALES OFFICES: 555 Madison Avenue, New York, New York. SOUTH: 1175 NE 125th Street, N. Miami, Florida. WEST: 500 Rodier Drive, Glendale, California. MIDWEST: 2201 Lunt Avenue, Elk Grove Village, Ill. HAWAII: 419 Waipamill Rd., Honolulu, Hawaii/AMPEX OF CANADA: 2832 Slough St., Malton, Ontario, Canada/AMPEX STEREO TAPES INTERNATIONAL: 1 Yarmouth Place, London W1Y 7 DW

# ONE STOPS

Raoul Shapiro  
Budisco Record Sales  
236 N.W. 29th St.  
Miami, Fla. 33127

Handleman Co.  
3979 N.W. 24th St.  
Miami, Fla. 33142

Mershaw of America  
6770 N.W. 37th Ct.  
Miami, Fla. 33147

E.C. Reyer  
2815 S.W. 63rd Ave.  
Miami, Fla. 33155

Southland Appl.  
9500 S.W. 69th Ct.  
Miami, Fla. 33156

H-&L  
66 W. Church  
Orlando, Fla. 32801

Record Supply  
2634 Taft Ave.  
Orlando, Fla. 32804

Southern Music  
503 W. Central  
Orlando, Fla. 32801

Budisco Co.  
1723 W. Cypress Ave.  
Tampa, Fla. 33606

Linda Santos  
Florida Electronics  
2106 Main St.  
Tampa, Fla. 33607

D & M Post Card & Record Co.  
5011 Georgia Ave.  
W. Palm Beach, Fla. 33405

## GEORGIA

Jack J. Gelbart  
L & F One Stop  
720 14th St. N.W.  
Atlanta, Ga. 30318

Hugh West  
Carol Sanford  
One Stop  
210 16th St. N.W.  
Atlanta, Ga.

Record Center  
2581 Piedmont Rd., N.E.  
Atlanta, Ga. 30324

Sound Marketing Inc.  
2209 Faulkner Rd.  
Atlanta, Ga. 30324

Ted Pousman  
Gate City One Stop  
1073 Huff Rd.  
Atlanta, Ga. 30318

Clarksville Record Sales  
P.O. Box 198  
Clarksville, Ga. 30523

Ralph's One Stop  
P. O. Box 117  
Demorest, Ga. 30535

Mr. Jenkins  
Best Music  
Leland Plaza  
Mahleton, Ga. 30059

Top Tunes  
1389 Church St. Extension  
Marietta, Ga. 30060

## ILLINOIS

T. H. Gorman  
ABCO  
3313 N. Springfield Ave.  
Chicago, Ill. 60618

All Records Service Co.  
2931 N. Pulaski Road  
Chicago, Ill. 60641

Little Al's  
3216 W. Lawrence Ave.  
Chicago, Ill. 60625

Barney's  
3234 W. Roosevelt, Rd.  
Chicago, Ill. 60624

John Galgano  
Galgano  
4135 W. Armitage Ave.  
Chicago, Ill. 60639

Joe's Record Shop  
550 E. 43rd St.  
Chicago, Ill. 60609

Lormar Distributors  
2311 N. Western Ave.  
Chicago, Ill. 60647

Marquette Records  
3215 W. 63rd  
Chicago, Ill. 60629

Mid American Specialty Dist.  
752 N. Milwaukee  
Chicago, Ill. 60607

Minetts Record Dist.  
2029 S. Michigan Ave.  
Chicago, Ill. 60616

Harry Losk  
The Music Box  
1410 So. Michigan  
Chicago, Illinois 60620

Irv Rothblatt  
New Deal Record Service  
1414 So. Michigan Ave.  
Chicago, Illinois 60605

Profit Vendors  
Little Al's  
3216 W. Lawrence  
Chicago, Illinois 60625

Rapid One Stop  
2623 N. Pulaski  
Chicago, Ill.

Singer One Stop  
2952 W. 63rd St.  
Chicago, Ill. 60629

World Distributors  
2021 So. Michigan Ave.  
Chicago, Ill. 60616

Decatur Rak Sales  
312 N. Water  
Decatur, Ill. 62523

Original One Stop  
312 N. Qater  
Decatur, Ill. 61521

Fred Sipiora  
339 So. Home Ave. Apt. 3F  
Oak Park, Ill. 60302

Hi Fi One Stop  
804 Main  
Peoria, Ill. 61611

Platter Record Shop  
208 S. 4th St.  
Springfield, Ill. 61102

## INDIANA

Ed Whitehead Enterprises  
817 North Fares Ave.  
Evansville, Ind. 47711

Tri-State  
3434 Broadway  
Fort Wayne, Indiana

Associated Records  
210 So. Meridian  
Indianapolis, Indiana 46225

Al Caleron  
Caleron Dist. Co.  
423 N. Alabama St.  
Indianapolis, Ind. 46206

C. Collier  
C & C Records  
1312 N. Capital St.  
Indianapolis, Ind. 46202

J & J Dist. Co.  
1661 W. 16th St.  
Indianapolis, Ind. 46202

## IOWA

John Pittman  
Dart Records  
515 E. Locust  
Des Moines, Iowa 50309

Bob Pockrandt  
Major Records  
1212 Grand Ave.  
Des Moines, Iowa 50309

Eddie Dunker & Chuck Taylor  
Mars Sales  
1630 Locust  
Des Moines, Iowa 50309

## KANSAS

Davidson One Stop  
1719 S. Hillside  
Wichita, Kansas 67211

Giant  
221 E. Williams  
Wichita, Kansas 67202

Al Driscoll  
Pioneer Distributor Company  
2955 So. Kansas  
Wichita, Kansas 67216

(Con't. on next page)

Super Music  
936 Bonifant St.  
Silver Spring, Md. 20910

## FLORIDA

Record Supply Co., Inc.  
290 Iris Road  
Casselberry, Fla. 32707

Dave Shedd  
Southern Record Services, Inc.  
1020 E. 14th St.  
Hialeah, Fla. 33010

Budisco Co.  
60 Riverside Ave.  
Jacksonville, Fla. 32202

# A-1 RECORD SALES

659 Tenth Ave., (212) Circle 6-1234, New York City 36

## EXCLUSIVE SPECIALISTS FOR THE JUKE BOX OPERATORS

The One-Stop with a complete selection of Singles, LP's, Standards and Background Music.

Specializing In Spanish Records

**FREE TITLE STRIPS**

Immediate Delivery  
Mail Orders Our Specialty

THE MOST COMPLETE ONE STOP & RACK SERVICE!  
RECORDS — TAPES

# GATE CITY

## RECORD SERVICE COMPANY

1073 HUFF RD., ATLANTA, GEORGIA — (404) 351-4821

Ted Pousman — Mgr.

# PROGRAM ONE STOP

FOR ALL YOUR RECORD AND TAPE NEEDS

INCLUDING:

- ORIGINAL ARTIST OLDIES AND STANDARDS
- COMPLETE SELECTION OF 8 TRACK CARTRIDGES & CASSETTES
- FAST, EFFICIENT SERVICE TO OPERATORS AND DEALERS
- MASTERWORKS DISTRIBUTOR
- FACTORY REPRESENTATIVE FOR ELECTRO-VOICE
- ACCESSORIES

ROUTE 22 AND FADEM ROAD  
SPRINGFIELD, NEW JERSEY 07081  
(201) 467-0003

RALPH SCHECHTMAN

DAVE CASEY

FRANK DIMARSICO

**'A LITTLE BIT  
OF SOAP''  
BANG 576**

**AUL  
AVIS**

**"NEIL DIAMOND'S  
GREATEST HITS"  
BANG LP 219**

**"BEST OF  
VAN MORRISON"  
BANG LP 222**

**IN CASE YOU HAVEN'T NOTICED,  
1970 IS DAWNING WITH A**

**BANG**  
RECORD

1650 Broadway, New York, New York 10019  
(212) 581-3747



# An important happening.... YOU'RE INVITED TO JOIN THE GREATEST CAST EVER ASSEMBLED IN SHOW BUSINESS HISTORY

Star or star-to-be, singer, musician, songwriter, actor, record producer, arranger, variety artist, etc.—if you're in show business (performing or creative talent, that is) there's a special place reserved for you in the forthcoming edition of **WHO'S WHO IN SHOW BUSINESS!**

Here's the book that leads to better bookings and more of them. Photographic-listing in **WHO'S WHO IN SHOW BUSINESS** puts (and keeps) you "where the action is" before a special audience of casting, booking, recording and advertising executives . . . across the country and around the world—and tells these important decision-makers . . .

**WHO** are you (Your name)

**WHAT** you look like (Your photograph)

**WHAT** you have done (Your credits)

**WHERE** you can be contacted (Your representative's name, address and phone number in a special **Contact Representatives** section)

Unique in its concept of embracing **all talents** in **all fields**, **WHO'S WHO IN SHOW BUSINESS** is the long-needed link between

talent and talent seeker. In fact, it's the only hard-cover, long-life directory reaching key executives in TV, radio, motion pictures, recordings, commercials, theatre, concert and opera, night clubs, circus and carnivals, etc.—in every major entertainment capital of the world—**plus** bonus distribution to libraries, advertising agencies, newspapers and magazines.

Here's another exclusive! In **WHO'S WHO IN SHOW BUSINESS** all photographic-listings are of equal size and prominence—and you get the same dramatic presentation as Frank Sinatra, Dionne Warwick, Petula Clark, Louis Armstrong, Ed Sullivan, etc.

For all the world of entertainment, **WHO'S WHO IN SHOW BUSINESS** is fast becoming the standard talent reference. This is an important happening. Don't let it happen without you!

Join the great cast now assembling for the new 1970 edition. Your photographic-listing costs just \$50 for year-long representation—the best career investment you could make. To assure you are "among those present", use the registration form to register now!

YOUR TALENT CATEGORY APPEARS HERE\*

**YOUR PHOTOGRAPH**

**YOUR NAME**

YOUR CREDITS

CONTACT:  
YOUR REPRESENTATIVE'S NAME



**SAMMY DAVIS, JR.**  
(Entertainer— Actor)  
B'WAY: "Golden Boy"; "Mr. Wonderful"—  
FILMS: "A Man Called Adam"; "Porgy  
& Bess"; "Oceans Eleven";  
"Robin & The Seven Hoods";  
NIGHT CLUBS: Sands Hotel, Las Vegas;  
Herrah's, Lake Tahoe; Hotel Deauville,  
Miami Beach—  
TELEVISION: "Ed Sullivan Show";  
"Sammy Davis, Jr. Show", etc.  
Contact: WM. MORRIS AGENCY



**ED SULLIVAN**  
"The Ed Sullivan Show" CBS-TV  
Contact: SULLIVAN PRODUCTIONS

**YOUR PHOTOGRAPHIC-LISTING  
HERE MAKES DRAMATIC IMPACT  
TO KEY EXECUTIVES IN EVERY  
MEDIUM OF ENTERTAINMENT**

ACTUAL SIZE 4 1/2" x 2 1/2" OF PHOTO-LISTING

**YOU'RE IN GOOD COMPANY!** Here are a few of the many prominent personalities impressively featured with photographic-listing in WHO'S WHO IN SHOW BUSINESS . . . from every medium of world-wide entertainment:

Roy Acuff  
Paul Anka  
Al Bano  
Louis Armstrong  
Harry Belafonte  
Brook Benton  
Cilla Black  
Jerry Blavat  
Booker T & The MG's  
Jimmy Bowen  
Marlon Brando  
Yul Brynner  
Glen Campbell  
Johnny Carson  
Maurice Chevalier  
Petula Clark  
Pat Cooper  
Don Costa  
Bing Crosby

King Curtis  
Kosaku Dan  
Frankie Davidson  
Sammy Davis, Jr.  
Skeeter Davis  
Four Seasons  
Connie Francis  
Alan Freeman  
Dizzy Gillespie  
Bobby Goldsboro  
Benny Goodman  
The Happenings  
Herman's Hermits  
Sol Hurok  
Brenda Lee  
Sophia Loren  
Dudley Moore  
Anthony Newley  
Buck Owens

Patti Page  
Jan Peerce  
Otto Preminger  
Freddy Quinn  
Richard Rodgers  
Nini Rosso  
Normie Rowe  
Frank Sinatra  
Frank Sinatra, Jr.  
Nancy Sinatra  
Jack Sterling  
Leopold Stokowski  
Shel Talmy  
Carla Thomas  
Marlo Thomas  
Jerry Vale  
Dionne Warwick  
Hank Williams, Jr.  
Ito Yukari

**IF YOUR TALENT CATEGORY IS LISTED HERE, YOU'RE ELIGIBLE FOR PHOTOGRAPHIC-LISTING**

Announcers  
Choreographers  
Comedy Artists  
Commentators  
Composers-Lyricists  
Concert Artists  
Dancers  
Disk Jockies  
Dramatic Artists  
Lecturers & Speakers  
Masters of Ceremonies  
Moderators  
Music Arrangers  
Musicians  
(including Conductors)  
Producers & Directors  
Record Producers  
Singers  
Variety Artists  
Writers

**WHO'S WHO  
IN  
SHOW  
BUSINESS**



The International Directory  
of the  
Entertainment World  
1780 Broadway, New York, N.Y. 10019  
(212) Ju 2-5118

SPACE RESERVATION FORM

Mail to:  
EDITORIAL DEPT.  
**WHO'S WHO IN SHOW BUSINESS, INC.**  
1780 Broadway  
New York, N.Y. 10019

**YES, COUNT ME IN!** Please reserve space for my photographic-listing in the 1970 WHO'S WHO IN SHOW BUSINESS . . . and send me the necessary biographical forms for listing of my credits, photo, talent category, etc. I understand the entire cost for year-long representation is just \$50.

Check enclosed

Bill me

(or)

Charge to my credit card:

American Express

Master Charge

Account No. \_\_\_\_\_

BankAmericard

Uni-Card

Carte Blanche

Name \_\_\_\_\_

Address \_\_\_\_\_

City \_\_\_\_\_

State \_\_\_\_\_ Zip \_\_\_\_\_



**WEST COAST MUSIC SALES**

2833 WEST PICO BOULEVARD • LOS ANGELES, CALIFORNIA 90006

# THE MOST COMPREHENSIVE AND COMPLETE SELECTION AVAILABLE OF TAPES, LP'S AND 45'S

**PRICE • SERVICE • SELECTION**

Classical • Jazz • Pop

**ALL ORDERS PROCESSED SAME DAY RECEIVED**

Phone • Write • Wire

**WEST COAST MUSIC SALES**

2833 WEST PICO BOULEVARD • LOS ANGELES, CALIFORNIA 90006

Phone (213) 735-1565

## TWENTY-TWO YEARS

YOU GET THE ACTION YOU WANT FROM:  
• • • STAN THE RECORD MAN • • •  
(HITMAKER OF THE SOUTH)

### ONE-STOP SERVICE TO STORES AND OPERATORS

★ Best Prices ★

• Export Service & Advice • Complete Stock of Singles • LP's—Little LP's • Gold Standard Catalogue • Oldies But Goodies • Spirituals • R&B—Pop—C&W • Juke Box Standards • Free Title Strips

So—No matter what your need may be—STAN THE RECORD MAN has it in stock and can give you ONE DAY SERVICE (Orders Shipped Same Day Received).

Phone (318) 422-7182

## STAN'S RECORD SERVICE

728 TEXAS STREET

SHREVEPORT, LOUISIANA

## ONE STOPS

The Record Shop  
221 E. Williams St.  
Wichita, Kansas 67202

### KENTUCKY

Central Electrns.  
217 E. First St.  
Campbellsville, Ky. 42718

Shirley One Stop  
4464 Dixie Hwy.  
Louisville, Ky. 40216

Ken Vine  
Vine One Stop  
400 E. Broadway  
Louisville, Kentucky 40202

The Wax Works  
320 Washington Ave.  
Owensboro, Ky. 42301

### LOUISIANA

Joe Asunto  
One Stop Records  
330 So. Rampart St.  
New Orleans, La. 70112

Jack Bernard  
Operators One Stop  
4130 Washington Ave.  
New Orleans, La. 70125

One Stop Record Shop  
350 So. Rampart St.  
New Orleans, La. 70112

Jack Bernard  
Operators One Stop  
4006 Eden St.  
New Orleans, La. 70125

Stan Lewis  
Stan's Record Shop  
728 Texas St.  
Shreveport, La. 71101

Floyd's Record Shop  
108 W. Main St.  
Villeplatt, La. 70586

### MAINE

Viners  
20-24 Broad St.  
Bangor, Maine 04401

Boyd Corp.  
84 W. Cove St.  
Portland, Maine 04101

New England Record  
212 Anderson St.  
Portland, Maine 04101

Roy Rice  
Portland Records  
84 W. Cove St.  
Portland, Maine 04101

### MARYLAND

Joe Sadler  
Musical Sales  
140 W. Mount Royal Ave.  
Baltimore, Md. 21201

Rolland Bollon  
New Deal  
1601 Guilford Ave.  
Baltimore, Md. 21202

One Stop Record Serv.  
2566 Madison Ave.  
Baltimore, Md. 21217

Mr. Buchman  
Redisco  
1815 Guilford Ave.  
Baltimore, Md. 21202

Stacey Record Dist.  
P.O. Box 2663  
Baltimore, Md. 21215

Atlas Rec. Rack  
2329 Penn Ave.  
Baltimore, Md. 21217

Super Music  
570 Gay St.  
Baltimore, Md. 21202

Harry Carter, G. Dinerstein  
Circle Dist. Corp.  
75 N. Beacon St.  
Boston, Mass.

Interstate Record Dist.  
211 South Locust St.  
Hagerstown, Md. 21740  
Mr. Carlton R. Smith

Sam Anoff  
Coronet Music  
4724 Bonnie Brae Rd.  
Pikesville, Md. 21208

### MASSACHUSETTS

Elliot Stone  
W & S Service  
128 Lincoln St.  
Allston, Mass. 02135

Harry Carter  
Gordon Dinerstein  
Circle Records  
75 North Beacon St.  
Allston, Mass. 02134

Gerry Flato  
Boston Record Dist.  
150 Vernon St.  
Boston, Mass. 02120

Harry Carter  
G. Dinerstein  
Circle Dist. Corp.  
75 N. Beacon St.  
Boston, Mass.

Dick Mitchell  
Dick's Records  
1355A Washington St.  
Boston, Mass. 02118

Record Whlrs of New England  
157 Washington St.  
Dorchester, Mass. 02716

Whitmarsh Music  
41 Bedford St.  
E. Bridgewater, Mass. 02333

Gabe Margolis  
Disco One Stop  
339 Broadway  
Everett, Mass. 02149

Somerset Corp.  
203 Plymouth Ave.  
Fall River, Mass. 02721

Leslie Sales  
590 Deadham St.  
Newton Center, Mass. 02159

W. S. Music Dist. Co.  
Teed Drive  
Randolph, Mass. 02363

Disco  
37 Fremont St.  
Somerville, Mass. 02143

One Stop  
30 Nashua St.  
Woburn, Mass. 01801

### MICHIGAN

Lucky's  
713 E. Midland St.  
Bay City, Mich. 48706

Martens Mobile Record Serv.  
2256 W. Laurence  
Charlotte, Mich. 48813

Martin & Snyder  
13200 W. Warren  
Dearborn, Mich. 48126

Angott Dist.  
2616 Puritan Ave.  
Detroit, Mich. 48238

Cadet Dist.  
13380 Capitol Ave.  
Detroit, Mich.

Tom Mutter  
Consolidated One Stop  
13254 Linwood  
Detroit, Mich. 48238

(Con't. on next page)

# Thank you D.J.'s for making The Archies' "Sugar, Sugar" the year's #1 hit.

*Don Kirshner*

D. J. Award – Cash Box  
"Most Programmed Record"

"Top Record #1" – Record World

NARM  
"Best Selling Single"

Cash Box  
Billboard  
Record World  
"Best Record of the Year" (Single)

The Carl-Alan Award  
"The Best Vocal Record of the Year"

BMI  
"Certificate of Merit"



A DIVISION OF  
KIRSHNER ENTERTAINMENT CORP.

**KIRSHNER**

Manufactured and distributed by RCA Records and Tapes.

# ONE STOPS

Record City  
41 S. Division St.  
Grand Rapids, Mich. 49502

Jackson Automatic  
643 E. Michigan  
Jackson, Mich. 49201

## MINNESOTA

Automatic Games & Supply  
Box 305  
Fairbault, Minn. 55021

Lieberman Record One Stop  
257 Plymouth Ave., North  
Minneapolis, Minn. 55411

Dick Moerbitz  
Acme Music Co.  
321 North Plymouth  
Minneapolis, Minn. 55411

Clifford Parker  
Acme Music Co.  
321 North Plymouth  
Minneapolis, Minn. 55411

Tom Prenevost  
All Records  
7600 Wayzata Blvd.  
Minneapolis, Minn. 55426

Irv Gorson & Dick Daly  
Dart Records, Inc.  
730 N. Lyndale Ave.  
Minneapolis, Minn. 55411

Bill Taylor & Noel Korngold  
Rapid Merchandising  
8175 Lewis Rd.  
Minneapolis, Minn. 55427

Bill Williams  
Sam Sales  
321 Plymouth Ave., N.  
Minneapolis, Minn. 55401

Mr. Van Goor  
Van Goor  
257 Plymouth Ave., N.  
Minneapolis, Minn. 55411

LeBaeu Novelty Sales Co.  
1902 University Ave.  
St. Paul, Minn.

Jim Christianson  
Jim's Records  
1724 University Ave.  
St. Paul, Minn. 55101

## MISSISSIPPI

Modern Appl. & Music  
Box 516  
McComb, Miss. 39648

## MISSOURI

Neva Cessnun  
One Stop Record Service  
3230 Roanoke Rd.  
Kansas City, Mo. 04111

Mrs. Davidson  
Davidson's One Stop  
321 So. West Blvd.  
Kansas City, Mo. 64108

Original One Stop Record  
3230 Roanoke Rd. Service  
Kansas City, Mo. 64111

L & R One Stop  
1901-05 Deimar  
St. Louis, Mo. 63155

Laclede Music Co.  
4060 Laclede Ave.  
St. Louis, Mo. 63108

Original One Stop Record  
2721 Pine St. Service  
St. Louis, Mo. 63103

Attn: Pat Blunda  
Pat's One Stop  
1911 Washington Ave.  
St. Louis, Missouri 63155

Record Van  
11154 Elbert  
St. Louis, Mo. 63136

Harry Brockman  
Uptown Music Shop  
617 Kings Highway  
St. Louis, Mo. 63108

Norman Hausfater  
Missouri Disc  
1900 Washington  
St. Louis, Mo. 63103

John Poole  
One Stop Record Service  
2721 Pine St.  
St. Louis, Mo. 63103

## NEBRASKA

Al Dahle  
Box 7 - Sta. "A"  
Omaha, Nebraska 68120

Davidson's One Stop  
1214 Farham  
Omaha, Nebraska 68102

Miss Dalrymple  
Lieberman One Stop  
809 So. 25th St.  
Omaha, Nebraska 68105

Records  
2500 Harney Ave.  
Omaha, Nebraska 69131

## NEW HAMPSHIRE

Manchester Music  
89 Manchester St.  
Manchester, N.H. 03101

## NEW JERSEY

Jack Gluben  
Able Record Sales  
730 Division St.  
Elizabeth, N.J.

Bernie Y  
Goldmor Dist. Corp.  
285 Bilmar Place  
Englewood, N.J. 07631

Regent Music  
14-16 Plaza Rd.  
Fairlawn, N.J. 07410

Relic Rack  
136 Main St.  
Hackensack, N.J. 07601

New Jersey One Stop Corp.  
467 Mundet Pl.  
Hillside, N.J. 07205  
Jerry Cohn, Edgries

Hal-Price  
Service One Stop  
16 Fenwick St.  
Newark, N.J. 07114

Belmont Record Shop  
350 Bloomfield Ave.  
Montclair, N.J. 07042

Branford Music  
14 Branford Pl.  
Newark, N.J. 07114

Ideal Records (Jack Kosloff)  
357 Lyons Ave.  
Newark, New Jersey 07112

New Jersey One Stop  
175 Clinton Pl.  
Newark, N.J. 07112

Sam Keenholtz  
Raymar Sales  
357 Lyons Ave.  
Newark, N.J. 07112

Hal Price  
Service One Stop  
16 Fenwick St.  
Newark, N.J. 07114

Jim Davis  
Mesia One-Stop  
413 George St.  
New Brunswick, N.J. 08901

Garden State Dist.  
68 W. Passaic St.  
Rochelle Park, N.J. 07662

Service One Stop  
Route 22 & Fadem Rd.  
Springfield, N.J. 07081

Program One Stop  
Route 22 And Fadem Rd.  
Springfield, N. J. 07081

## NEW MEXICO

Gulf Mart  
5000 San Mateo N.E.  
Albuquerque, N.M. 87109

Meio-D-Lane  
2421 Aztec N.E.  
Albuquerque, N.M.

Wertern Wholesale  
1701 Williams S.E.  
Albuquerque, N.M. 87102

## NEW YORK

Almor & Co.  
10 Leonard St.  
Amsterdam, N.Y. 12010

Fulton Radio Serv.  
490 Clarmont Pkwy.  
Bronx, N.Y. 10457

Kape International  
Box 74E  
Brooklyn, N.Y. 11234

Town Hall (Ben Reminick)  
9131 Bedell La.  
Brooklyn, N.Y. 11236

L. Schoenberger-Schony's  
2602 Tilden Ave.  
Brooklyn, N.Y. 11226

(Con't on next Pa)

Martin & Snyder  
8880 Hubbell St.  
Detroit, Mich. 48228

New Deal Record Serv.  
15329 Liverois Ave.  
Detroit, Mich. 48238

State Song Shop  
3419 Hastings  
Detroit, Mich.

Larry Deming  
Lake Shore Dist.  
2605 Lake Shore Drive  
Excanba, Mich. 49829

## L. SCHONBERGER

# "SCHONY'S" ONE-STOP

(Established 1943)

2602 TILDEN AVENUE

BROOKLYN 26, NEW YORK

(PHONES: BUCKMINSTER 7-3576 AND 7-4581)

WE STOCK ALL LABELS. SPECIALIZING IN OLD  
RECORDS. ALL ORDERS SHIPPED SAME DAY.

## MARTIN & SNYDER ONE-STOP, INC.

THE MOST COMPLETE ONE-STOP IN THE MIDWEST  
Complete Line of Standards and Foreign Records

We also carry a complete line of 8-track and cassette tapes

# IF IT'S A RECORD... WE HAVE IT

8880 Hubbel

Detroit, Michigan 48228

(313) 272-7800

Chet Kajeski, President

## OUR 15th YEAR AS WESTCHESTERS LEADING ONE STOP-RACK JOBBER

# STEADMAN

Complete Rack-Jobbing & One-Stop Service

FOR RECORDS, TAPES & ACCESSORIES

### STEADMAN

200 So. 14th Ave., Mt. Vernon, N.Y. 10550

(914) OW-9-3166 (212) 994-6380

IN N.Y.C. SEE WIN RECORDS



# ONE STOPS

Steve Brodie  
c/o Buffalo One Stop  
959 Main Street  
Buffalo, N.Y. 14203

Jerry Meyers  
Action One-Stop  
875 Main Street  
Buffalo, N.Y. 14203

Joe Pinter  
Buffalo One Stop  
959 Main Street  
Buffalo, N.Y. 14203

Florence One Stop  
875 Main St.  
Buffalo, N.Y. 14203

Merit Vending Co.  
1503 Broadway  
Buffalo, N.Y. 14212

Transcontinent Record  
959 Main St. Sales  
Buffalo, N.Y. 14203

Bernie Boorstein  
Double B Records  
240 Merrick Rd.  
Freeport, L.I., N.Y. 11520

Ed Smith  
Wilmi Sales  
3W. Moreland  
Hicksville, L.I., N.Y. 11301

Raymar Sales  
170-21 Jamaica Avenue  
Jamaica, N.Y. 11432

Stratford Dist.  
178-22 Jamaica Ave.  
Jamaica, N.Y. 11432

Irv Shenker  
Tri-Boro Records  
89-27 165th St.  
Jamaica, N.Y. 11432

L & L Distributors  
Shaker Park  
Latham, N.Y. 12110

Bee Gee Record Merchandisers  
10 Northway La., No.  
Latham, N.Y. 12110

Gemini Record Corp.  
32-01 36th Ave.  
L.I. City, N.Y. 11106

Al Levine  
New Deal  
45-18 Court Sq.  
Long Island City, N.Y. 11101

New Deal Record Service Corp.  
46-50 54th Ave.  
Maspeth, N.Y. 11378

Len Book  
Steadman One Stop  
200 South 14th Ave.  
Mount Vernon, N.Y. 10550

James Bilotta  
Bilotta Enterprises  
Newark, N.Y. 14513

A-1 Records  
659 10th Ave.  
New York, N.Y. 10036

All One Stop Dist.  
315 W. 47th St.  
New York, N.Y. 10036

Elliot Blaine  
Consolidated One Stop  
315 W. 47th St.  
New York, N.Y. 10036

Eastern Records  
666 10th Ave.  
New York, N.Y.

L. Guttenplan  
Gen-Mar Dist.  
Box L - Old Chelsea Station  
New York, N.Y. 10011

Hitsville  
600 W. 125th St.  
New York, N.Y. 10027

King Karol One Stop  
444 W 42nd St.  
New York, N.Y. 10036

King Koral  
111 W. 42nd St.  
New York, N.Y. 10036

New York Record Dist.  
1290 Ave. of Americas  
New York, N.Y. 10019

Joe Reimer  
Reimer Trading Co.  
2 W 31st St.  
New York, N.Y. 10001

David Rothfeld  
E. J. Korvette, Inc.  
1180 6th Ave.  
New York, N.Y. 10017

Record Shack  
2132 2nd Ave.  
New York, N.Y. 10029

Stratford Records  
184-23 Jamaica Ave.  
Hollis, L.I.  
New York, 11423

George Weiss  
Win Records  
856 9th Ave.  
New York, N.Y. 10019

Bandstand Records  
15½ N. Main St.  
Pt. Chester, N.Y. 10573

Toy House of Hudson  
Manchester Rd. Valley  
Poughkeepsie, N.Y. 12603

Herb Durman  
Rochester One-Stop  
215 So. Monroe  
Rochester, N.Y. 14607

John Schreiber  
Star One Stop  
17 Clinton Ave., No.  
Rochester, N.Y. 14604

Leonard Silver  
172 Halwell Dr.  
Snyder, N.Y. 14226

Ralph La Rosa  
Syracuse One Stop  
333 W. Lafayette St.  
Syracuse, N.Y. 13202

Tom Tarantelli  
T.O.P. Distributing Co.  
475 Oswego Blvd.  
Syracuse, N.Y. 13202

All Records  
118 Swalm St.  
Westbury, N.Y. 11590

Mal Hurwitz  
6 Dellwood Rd.  
White Plains, N.Y. 10605

All Records  
67 Hillside Ave.  
Williston Park, L.I., N.Y. 11596

## NORTH CAROLINA

Bid Distributors  
124 W. Morehead St.  
Charlotte, N.C. 28202

Southeastern One Stop & Southeaster  
Records Merchandiser  
126 W. Morehead St.  
Charlotte, N.C. 28202

## OHIO

M & G Record Serv.  
47 E. Mill St.  
Akron, Ohio 44308

Vern Hawk  
Ambat Records  
1667 Central Parkway  
Cincinnati, Ohio 45214

Jack Pierce  
Royal Distributors  
1210 Glendale-Milford Rd.  
Cincinnati, Ohio 45215

(Con't on next Page)

# HEAVIEST

IN  
NORTHERN CALIFORNIA

We're heaviest because we've got what it takes to give you what you want when you want it... Records or tapes, 8-track and Cassettes. Special orders. Our trucks deliver. Free Parking. Same Day Shipping. Place your order Monday thru Friday 8:00 a.m. to 5:00 p.m. Call:

Fred Pollastrini — One Stop Manager

## BOS 1

Direct Line 415 / 626-5494

### H.R. BASFORD COMPANY

800 MARIPOSA STREET, SAN FRANCISCO, CALIFORNIA 94107

## SERVING THE SOUTHEAST

Complete One-Stop & Rack  
Record and Tape Service

**SOUTHEASTERN  
RECORD MERCHANDISERS, INC.**

2706 Freedom Dr., Charlotte, N.C.  
(704) 399-5633

## RECORD MANUFACTURER

(Con't from Page 60)

**WILBEE RECORDS**  
160 Wood Street  
Wilkes-Barre, Pa. 18702

**WILDCAT**  
1611 Broadway  
San Antonio, Texas

**WIN**  
27 Stegman Pl.  
Jersey City, N.J.

**WIN GATE**  
See Golden World

**WINDFALL**  
See Bell

**WINDY C**  
See Cameo

**WINDSOR**  
See CIRCA

**WING**  
See Mercury

**WINRO**  
See Together

**WIZDOM**  
See Pickwick

**WONDERLAND**  
235 W. 46th St.  
N.Y.C. 10036

**WORD**  
P.O. Box 1790  
Waco, Texas

**WORLD**  
See Robbee

**WORLD PACIFIC**  
See Liberty

**WORLD WIDE**  
524 Plasters Ave.  
Atlanta, Ga. 30324

**WORLD WIDE**  
56 Ferry St.  
Newark, N.J.

**WYNCOTE**  
c/o Cameo Parkway

**YEW**  
250 W. 57th St.  
N.Y.C. 10019

**YORKTOWN**  
347 Litchfield Ave.  
Babylon, N.Y.

**YOUNER**  
c/o Gaye Talent Production  
P.O. Box 13612 Station K  
Atlanta, Ga. 30324

**YOUNG PEOPLE'S**  
100 Sixth Ave., N.Y.C.

**ZAPPLE**  
See Capitol

**ZAP-ZING**  
See Cotillion

**ZEBRA**  
31 Brompton Rd.  
Garden City, N.Y.

**ZODIAC**  
7447 N. Linden  
Skokie, Ill.

**ZONE**  
P.O. Box 4692  
Memphis, Tenn.

**ZOOM-R2**  
16 W. 55th St.  
NYC 10019

# **BANDANA**

**ENTERPRISES LTD.**

**an organization which has helped bring to the fore  
such notable artists as**

**JOE COCKER  
TEN YEARS AFTER  
JETHRO TULL  
SAVOY BROWN  
KING CRIMSON**

**through the process of creative management**

## **Bandana West**

**Bill Anthony, Vice President**  
1155 N. La Cienega Blvd.  
Los Angeles, Cal. 90069  
(213) 652-1772

## **Bandana East**

**Dee Anthony, Managing Director**  
1060 Park Ave.  
New York, N. Y. 10028  
(212) 348-8133

**PUBLIC RELATIONS: Gershman/Swaney & Gibson**

Willie Mitchell

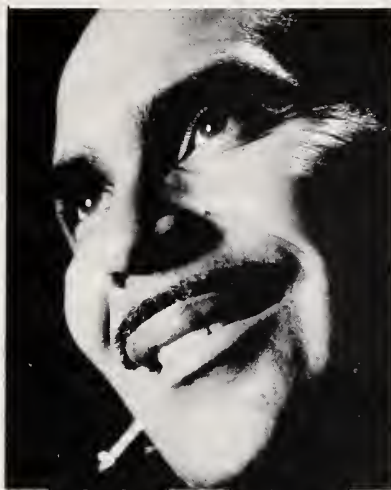

Ace Cannon



Al Green



**Great  
R&B artists...  
Fabulous  
Memphis sound...**

**Including the powerful catalog of Bill Black's Combo**

**that's  
Hi** RECORDS

Distributed throughout the world by The Decca Record Company Ltd., London, England

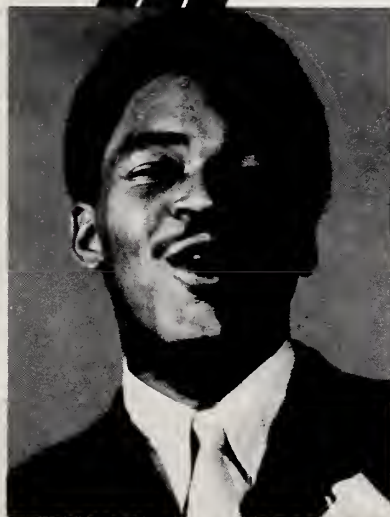

Don Bryant



Ann Peebles



# ONE STOPS

Jack Shue  
Canfield Supply Service, Inc.  
417 Northland  
Cincinnati, Ohio 45240

Dave Harmon  
Century Music  
849 North High Street  
Columbus, Ohio 43215

George Freeman  
Northern One Stop  
2006 Prospect Ave.  
Cleveland, Ohio 44115

Ambat Records  
1336 Xenia Ave.  
Dayton, Ohio 45410

Stark Record Service  
8000 Freedom Ave., N.W.  
North Canton, Ohio 44702

Sonny Kristoff  
Buckeye  
5 E. Main St.  
Springfield, Ohio 45502

F. Valicenti  
Plaza Records  
309 Boardman Canfield Rd.  
Youngstown, Ohio 44512

## OKLAHOMA

Advance One Stop  
129-A N.W. 23rd St.  
Oklahoma City, Okla. 73103

Phil Burlingame  
Phil's One Stop  
705 N.W. 4th St.  
Oklahoma, Okla. 73102

Nancy Smith  
All Records  
520-522 Classen Blvd.  
Oklahoma City, Okla. 73106

Record World  
1516 N. Fordson Dr.  
Oklahoma City, Okla.

Dee Horn  
Bill's T Record Shop  
19 North Harvard  
Tulsa, Okla. 74115

## OREGON

Sunset Automatic Music Co.  
P. O. Box 89  
Coos Bay, Oregon 97420

Thompson  
62 Broadway  
Eugene, Oregon 97401

Nate Feedes  
Portland One Stop  
511 Southwest 6  
Portland, Oregon 97204

Dave Smith  
Sea Port Record One Stop  
21 N.E. 7th Ave.  
Portland, Oregon 97232

Sixth Ave. Records  
511 S.W. Sixth  
Portland, Oregon 97204

## PENNSYLVANIA

Irv Perlman  
Roper Records  
8125 Hawthorne La.  
Elkins Park, Pa. 19117

David Press  
D & H Dist.  
2525 N. 7th St.  
Harrisburg, Pa. 17110

Ken Betchel  
Greens Records  
127 S. First St.  
Lehighton, Pa. 18235

Bandstand Record Service  
1400 W. Somerset St.  
Phila., Pa. 19132

Jerry Rappoport-Mary Picano  
Bandstand Record Service  
2522 N. Broad St.  
Phila., Pa. 19132

Terry Rosen  
I. J. Morgan Co.  
51st St. & Parkside Ave.  
Phila., Pa. 19131

Eastern  
334 N. Broad  
Phila., Pa. 19102

Ham-Cil  
855 N. Broad St.  
Phila., Pa. 15222

Ed McKeown  
New Deal 1  
2505 Broad St.  
Phila., Pa.

Herb Slotkin  
Slotkin's  
4095 Lancaster  
Phila., Pa. 19104

Sid Williams  
Williams One-Stop  
817 No. Broad St.  
Phila., Pa. 19123

East Coast  
633 Liberty Ave.  
Pittsburgh, Pa. 15222

Travis Klein  
Klein's Logan Variety  
Store  
2111 Center Ave.  
Pittsburgh, Pa.

Donnie Bray  
John Roberts Co.  
5222 Centre Avenue  
Pittsburgh, Pa. 15232

James Grimes  
1500 Creedmore Ave.  
Pittsburgh, Pa. 15226

Donny Bray  
Regal Records  
1623 Blvd. of Allies  
Pittsburgh, Pa. 15219

Gene Shakela  
Regal Records  
1623 Blvd. of Allies  
Pittsburgh, Pa. 15219

United  
Dept. 1-A  
411 Gordon St.  
Reading, Pa. 19601

Richard Platkin  
Bellmash Dist. Co.  
Elmhurst Blvd. & Watres Dr.  
Scranton, Pa. 18505

Dee Jay  
528 Main St.  
Stroudsburg, Pa. 18360

William Barnes  
Barnes Record Dist.  
13 W. White St.  
Summit Hills, Pa. 18250

## RHODE ISLAND

Mr. Zeidman  
Beacon Shops  
821 No. Main St.  
Providence, R.I. 02915

(Con't. on next page)



# ! RIGHT HERE!

FOR THE BEST IN

## ONE-STOP RECORD SERVICE

NOW CELEBRATING OUR 24th & GREATEST YEAR SERVICING  
DEALERS IN THE 50 UNITED STATES AND THROUGHOUT THE WORLD

**THE WISE DEALER IS THE ONE WHO REALIZES THAT HE CANNOT AFFORD TO DEAL WITH ANYTHING LESS THAN THE BEST RECORD SUPPLY SERVICE AVAILABLE — WHO UNDERSTANDS THAT HE DOES HIMSELF AND HIS BUSINESS AN IRREPARABLE DISSERVICE IN SETTLING FOR A MEDIOCRE SUPPLY SERVICE, WHEN A SUPERIOR SERVICE IS AVAILABLE.**

**LET OUR LARGE ORGANIZATION AND VAST EXPERIENCE HELP YOU TO MAKE EXTRA SALES, MORE CUSTOMERS & GREATER PROFITS WITH OUR RELIABLE, EFFICIENT, SERVICE AND OUR UNBEATABLE FILL OF YOUR ORDERS.**

— TRY US AND CONVINCE YOURSELF —

### WE GUARANTEE:

- MOST COMPLETE FILL OF YOUR ORDERS (WE INVITE YOU TO TRY US ON THE ITEMS THAT YOUR PRESENT SUPPLIERS HAVE BEEN UNABLE TO FILL).
- RELIABLE, EFFICIENT, SAME DAY SERVICE
- COMPETITIVE PRICES, SPECIALS, ETC.
- CUSTOM TAILORED COOPERATION TO SUIT YOUR PARTICULAR BUSINESS NEEDS.

WE CARRY THE MOST COMPLETE STOCK OF "OLDIE" 45's IN THE COUNTRY. WRITE FOR OUR NEW GIANT "OLDIES" CATALOG LISTING 5000 BEST SELLING "GOLDEN OLDIES." THERE'S BIG BUSINESS IN 45 RPM OLDIES. LET US HELP YOU TO GET YOUR PROPER SHARE OF IT.

- COMPLETE INVENTORY OF STEREO-8 TAPE CARTRIDGES, CASSETTES
- GET YOUR SHARE OF THIS FAST GROWING, "EXTRA" BUSINESS. WRITE! WIRE! PHONE! FOR DETAILS. MAKE THIS MOST IMPORTANT MOVE TO IMPROVE YOUR BUSINESS

NOW!

# TOWN HALL

RECORD ONE-STOP, INC.

"FIRST WITH THE NEWIES— MOST WITH THE OLDIES"

9131 BEDELL LANE

212-BR 2-9702

BROOKLYN, N.Y. 11236

## WE MEAN BUSINESS

New York's leading one-stop, rack Jobber and exporters of records and tapes.

Fast, FAST service on all foreign orders.  
ALL EXPORT ORDERS ARE PROCESSED  
THE SAME DAY RECEIVED.

# WIN RECORDS INC.

### COAST TO COAST

Local dealers, please contact  
George Weiss for latest catalog  
and low, low prices.

FOR ALL YOUR RECORD NEEDS.

## WIN RECORDS, INC.

858 9th Ave., New York City • JU 2-0130

In Westchester  
See  
Steadman

*“Dedicated to the New Era”*



*AMARET Records*

*a Division of American Association of Recorded Talent, Inc.  
1717 North Highland Avenue, Hollywood, California 90028*

*AMAK Music Corp. (ASCAP)*

*DAGE Music Corp. (BMI)*

*KENNY MYERS  
President*

# ONE STOPS

## SOUTH CAROLINA

Savitz  
115 Public Sq.  
Abbeville, S.C. 29620

South Carolina One Stop  
107 E. Washington St.  
Abbeville, S.C. 29620

Fox  
537 King St.  
Charleston, S.C. 29403

Music Mart  
164 E. Washington St.  
Burlington, Wisc. 53105

Jos. Hoffman  
Hoffman's  
5707 Sixth Ave.  
Kenosha, Wisc. 53140

Gordy Pelzek  
Record City  
1136 W. Donges Bay Rd.  
AIR MAIL 104N  
Mequon, Wisc. 53092

Dave Wolfson  
Record City  
1136 W. Donges Bay Rd.  
AIR MAIL 104N  
Mequon, Wisconsin 53092

Midwest Radio  
3414 W. North Ave.  
Milwaukee, Wisc. 53208

Jeff Ballman  
Modern Rack Sales  
5825 North 96th St.  
Milwaukee, Wisc. 53225

Stu Glassman  
Radio Doctors  
213 West Wells St.  
Milwaukee, Wisc. 53203

Radio Doctor  
2152 North 3rd St.  
Milwaukee, Wisc. 53212

Record City  
5600 W. North Ave.  
Milwaukee, Wisc. 53208

J. Huennekens  
Soulville  
507 Main St.  
Racine, Wisc. 53401

## TENNESSEE

Jack's  
906 Market St.  
Chattanooga, Tenn.

Rack Enterprises  
51 Broad St.  
Cookeville, Tenn. 38501

Knoxville Phono Record Rack  
2000 Western Ave.  
Knoxville, Tenn. 37921

Dale Clark  
Tucker's Record Shop  
22½ Market St. & Mall  
Knoxville, Tenn. 37901

Bluff City Records  
3442 Jackson  
Memphis, Tenn. 38122

Home of Blues  
107 Beale St.  
Memphis, Tenn. 38103

Poplar Tunes  
306 Poplar  
Memphis, Tenn. 38103

Buckley's  
1707 Church St.  
Nashville, Tenn. 37203

Dudley Bonds  
D & G Record Mart  
542 Fatherland St.  
Nashville, Tenn. 37202

Ernie Record Mart  
179 Third St. No.  
Nashville, Tenn. 37213

Helen Hall  
Hermitage Music  
469 Chestnut St.  
Nashville, Tenn. 37203

Sanders Dist.  
612 8th Ave., So.  
Nashville, Tenn. 37203

Volunteer  
435-37 Ave. No.  
Nashville, Tenn. 37209

## TEXAS

W-M One Stop  
1601 West Third  
Amarillo, Tex. 79106

Ed Perry  
Western Mdse.  
1601 W. 3rd Ave.  
Amarillo, Tex. 79100

Don Bresler  
D.J.  
2315 Briarwood La.  
Carrollton, Tex. 75006

Alta Hays  
Big State Record Distrs.  
1337 Chemical Row  
Dallas, Tex. 75207

Lee Trimble  
Westex Record Service, Inc.  
1102 Lupo Drive  
Dallas, Tex. 75247

Lindy Cash  
B & C Record Sales  
5821 Normont Way  
El Paso, Tex. 79912

M.B. Krupp  
311 So. Santa Fe St.  
El Paso, Texas 79901

Joe Gillman  
Star Discos  
100 Texas Ave.  
El Paso, Tex. 79946

Sunland  
2227 Texas Ave.  
El Paso, Tex. 79901

Bud Daily  
H.N. Daily Records  
314 E. 11th St.  
Houston, Tex. 77008

Margie Kunkel  
United One Stop  
1613 St. Emanuel St.  
Houston, Texas 77003

Margie's One Stop  
2005 Polk  
Houston, Texas

Russ Reader  
Record Service Company  
610 Dennis St.  
Houston, Tex. 77006

Bob Iseral  
Recordland U.S.A.  
3811 Ave. 'A'  
Lubbock, Tex. 79408

Bill McGee  
Santone Sales  
121 Navarro  
San Antonio, Tex. 78205

E & R Record Shop  
911 E. Houston  
San Antonio, Tex. 78205

Russell Schramm  
E & R Record Shop  
305 So. Main  
San Antonio, Tex. 78204

Charles Cole  
Tanner 'N' Texas  
1414 W. Poplar  
San Antonio, Tex. 78201

Paco Betancourt  
Rio Grande Music  
P. O. Box 861  
San Benito, Tex. 78586

## UTAH

Billinis Distributors  
3575 So. 700 West  
Salt Lake City, Utah

Dick La Duke  
R. F. Jones  
75 So. 2nd West  
Salt Lake City, Utah

Dick Leduc  
Record Express  
209 E. Ninth South  
Salt Lake City, Utah 84111

John Billini's  
Utah Sundries  
1550 S. Redwood Rd.  
Salt Lake City, Utah 84104

## VIRGINIA

Giant Music  
133 S. Washington St.  
Falls Church, Va. 22046

Pat Cohen  
Pat's One Stop  
1st & Canal Sts.  
Richmond, Va. 23219

Ponderosa Dist. Inc.  
216 E. Main St.  
Richmond, Va. 23219

Deans One Stop  
214 E. Main St.  
Richmond, Va. 23219

## WASHINGTON

Lou Choate  
Seattle Record One Stop  
125 First Ave., North  
Seattle, Wash. 98109

Larry Dolgoff  
Disc City One Stop  
410 Elliott Ave., West  
Seattle, Wash. 98119

Tosi Hori  
4137 15th South  
Seattle, Wash. 98108

Seattle Record One Stop  
125 1st Ave., No.  
Seattle, Wash. 98109

## WEST VIRGINIA

Elkins Music  
160 Court St.  
Charleston, W. Va. 25301

Courts  
Box 9  
Culloden, W. Va. 25510

Mac McGlynn  
Music Man  
803 8th Ave.  
Huntington, W. Va. 25701

## WISCONSIN

Mrs. Pierce  
C. S. Pierce Music  
602 W. 3rd Ave.  
Brodhead, Wisc. 53520



LEE MAGID PRESENTS . . .

Pop

Soul

Jazz

Blues



Pop

Soul

Jazz

Blues

The Art-Forms Ltd.

With Their First RCA Release

"I'M A BAD MAN"

And

"Apple Trees And Butterflies"

Arranged And Conducted By Paul Lopez  
Written By Art Reynolds



William Morris Agency

Produced By Lee Magid 5750 Melrose Ave. Hollywood, Calif. (213) HO 3-2353



# Record Distributors

## ARIZONA

PHOENIX—(602)

●ARC Inc.  
2029 N. Black Canyon Highway  
Margo Grover 252-4013  
(A&M, ABC, Abnak, Accent, AGP, Almo, Amy, Ashley, Atco, Atlantic, B.T. Puppy, Back Beat, Bangoo, Bang, Bell, Bluesway, Britannia, Boone, Buddah, Bunky, Cadet, Canterbury, Challenge, Chapter One, Chart, Checker, Chess, Coliseum, Command, Common Wealth, Cotillion, Crimson, Curtom, Dakar, Deram, Diamond, Dionn, Direction, DJM, Dollie, Dooto, Double Shot, Duke, Dunhill, Dynavoice, Earl, Elektra, Elf, Enterprise, Era, ESP, Excello, Fantasy, Flashback, Four Corners, Galaxy, Gamble, Goldwax, Grand Award, Hi, Hip, Hob, Hurricane, Impact, Impression, Impulse, Independence, Jab, Jad, Jamie, Janus, Jay Gee, Jetstar, Jewel, Jubilee, Kama Sutra, Kapp, Kent, King, Laurie, London, Mainstream, Mala, Mar-V-Lus, Metro-media, MOC, Monument, Music Guild, Musicor, Nashboro, New Voice, Nonesuch, Omen, One-Der-Ful, Original Sound, Parrot, Paula, Pavillion, Peacock, People, Pepper, Phil-La Of Soul, Philly Groove, Plantation, Polydor, Pree, Presta, Ramco, Ranwood, Rising Sun, Ronn, Roulette, Senate, Scepter, SGC, Shout, Sire, Song Bird, Sound Stage 7, Sport, Spor, SSS International, Starday, Star Stime, Stax, Stop, Swing, T Neck, Tangerine, Team, Tell, Thomas, 20th Century Fox, Uni, Volt, Wand, Westminster, White Whale, Whitehall, Whiz, Windfall, ARV, Bego, Bernal, Cap-Latino, Comenta, Disco Grande, DLV, El Pato, El Zarape, Impacto, Los Relampagos, Marsol Musart, Sunglow, Teardrop, Viva)

Arizona Sundries, Inc.  
2949 N. 30th Avenue  
George Souvall 272-2363  
(Disneyland, RCA)

## CALIFORNIA

LOS ANGELES—(213)

ABC Record and Tape Sales Corp.  
3334 LaCienega Place  
Norm Larson 870-8711  
(ABC, Dunhill, Command, Bluesway, Impulse, Riverside, Tangerine)

Advance Distributing Services  
6376 Yucca Street  
Tim Gayle 463-2151  
(Advance, Baton, Carol, Carolyn, Chroma, Daisy, Dare, Fury, Roondop, Sommers, Thompson, Timely)

Aldo Distributors  
10965 Bluffside Drive #27  
(Studio City)

Al Stewart 761-1040  
(A-Okay, American, ARV, Audio Book, Appaloosa, Alpha West, Baronet, Bay, Bible Voice, Bresee, Frank-Prod's, C-Ray, Calmis, Celebrity, Celestial, Chesterfield, Combo, Copper State, Crisis, Dime, Eagle, Empala, Furth-Gold, Glenoiden, Granger, HMS. ILA, Jay-Jay, Kay-Y, LaSalle, Lisa, Me-Meow, Mojo, Mundo Allegre, NTR, Orpheus, Reness, Romark, Sage & Sand, Sidewinder, Stinson, Supreme Prods., 3-H's, Tell Int., Titan, Titan II, Service, MARC, Tri-Disc, Demon, Virgitone, Voice of Scripture, Winit, Yardbird, Whittier, Midas, Eric)

●Alshire International  
222 West Orange Grove Ave., (Burbank)  
Al Sherman 849-4671  
(Alshire, Somerset, Stereo-Fidelity, Audio-Spectrum, A-S, Peter Rabbit)

●California Record Distributors  
22433 So. Vermont,  
(Torrance)  
Ralph Kaffel 386-1821  
(AA, A-Bet, Archive of Folk Music, Amy, Audio Arts, Audio Blues, Aurora, Baroque, Bell, Bethlehem, Blue Cat, Bluesville, Buddah, Cadet, Carnival, Cetra, Checker, Chess, Chisa, Cobblestone, Cancer, Cotillion, Counterpoint, Crescent, Curtom, DC, DJM, Dakar, Diamond, Drew, ELF, Esp, Esoteric, Everest, Excello, Fairlane, Fantasy, Festival, Galaxy, Gamble, Golden, Goldwax, GRT, Groovesville, Harbour, Hi-Fi, Instant, Kent, King, La Comedie Francaise, Laurie, Mala, Maxx, Modern, Monument, Moodsville, Musicland USA, Nashboro, Period, Phil L.A. of Soul, President, Prestige, Pzazz, Queen, Rampart, Renaissance, Revlot, Revue, Rising Sons, Royal American, RSVP, Rust, Sansu, Scala, Sidra, Solid Hit, Spar, Stang, Starday, Sound Stage 7, Sun, Super K, Team, Thomas, T-Neck, Tradition, True Sound, Village Gate, Way-out)

●Capitol Record Dist.  
3117 San Fernando Rd.  
Dave Cline 257-8224  
(Angel, Capitol, Seraphim, Apple, Fame, In-ctus, Trump)

Chapman Dist. Co.  
2645 W. Pico Blvd.  
Al Chapman 385-3636  
(Accent, Alwin, Bible Voice, Canaan (Religious), Capitol (Religious only), Carole, Christian Faith, Columbia (Religious Only), Cabot, Chidrens Rec. Guild, Cambridge, Connoisseur Society, Conversaphone Lang., Cricket (Religious), Dictation Disc, Fraternity, Hansa, Hayden Society, Hiitop, Happy Time, Living Language, Milestone (45 only), Monitor, Motivation, Music Minus One, Orion, Peter Pan, Pickwick, Gateway Language, Light (Religious), Heartwarming (Religious), Serenus, Skylite, Spoken Arts, Sword (Religious), Supreme, Swampfire, Young People's Records, Welte, Word (Religious), Zondervan (Religious), Stylist  
TAPE: (Word-8tr.)  
CASSETTE: (Cabot, Conversation Lang., Living Language, Gateway Lang., Word)

Creative Sound  
9000 Sunset Blvd.  
Robert C. Cotterell 271-4843  
(Creative Sound, Mark, Song Power, Vibrant)

●Columbia Records  
6430 Sunset Blvd.  
Bob Murphy 466-2481  
(Columbia, Date, Harmony, Barnaby, Epic, Fillmore, Gazette, Kinetic, Blue Horizon, Odyssey, Okeh)

●Decca Distributing Corporation  
6750 Santa Monica Blvd.  
Mel Nimon, Jack Lombardo 463-7126  
(Brunswick, Berlitz, Bravo, Coral, Decca, MTA, Viva, Vocalion)

Festival Record Dist.  
2769 W. Pico Blvd.  
John Filcich 737-3500  
(Ace of Clubs, Alector, Apon, Artia, Avoca, B&F, Balkan, Barenreiter, Bruno, Canary, Colonial, Colosseum, Continental, Dana, Dover, Eurotone, Gateway, Gregorian, Helios, Institute, Israel Music Foundation, Kismet, Nina, Parakeet, Rainbow, Standard, Ultraphone)

●Hitsville, Inc.  
22433 So. Vermont  
(Torrance)  
Ralph Kaffel 775-7591  
(Gordy, Motown, Rare Earth, Soul, Tamla, VIP)

●Liberty/UA Distributing Corp.  
1024 N. Orange Dr.  
Stuart Marlowe 462-6733  
(Blue Note, Imperial, Liberty, Minit, Solid State, Soul City, Sunset, Unart, United Artists, Veep, World Pacific)  
TAPE: (Liberty, Sunset)

●London Records of Calif. Inc.  
1555 West Rosencrans Ave.  
(Gardena)  
Mario DeFelippo 770-8200  
(Ashley, Chapter 1, Coliseum, Deram, Hi, London, Parrot, Phase 4, Sire, Threshold, Monument, Disneyland, Kent Modern, Roulette)  
TAPE: (All Labels)

●Merit Distributing Corporation  
22433 So. Vermont  
(Torrance)  
Ralph Kaffel 775-7591  
(Atlantic, Contemporary, Enterprise, F Fountain, Godd Time Jazz, Karen, Koko, L, Mainstream, Moonglow, Peter, Public, Specialty, Stax, Vault, Venus, Volt)

●Music West  
19110 S. Vermont Ave.  
(Torrance)  
Merritt B. Kirk 321-5666  
(Camden, Cap-Latino, Childcraft, Colg Disneyland, Fontana, Intrepid, Kirshner, I, light, Mercury, Philips, Playcraft, Poppy, Pt RCA, Smash, Victor Co. of Japan, Victo Wayside, RCA Test Records)  
TAPE: (All Domestic Lines (all configurati RCA Mexicana (8 track), Victor Co. of J (8 track) Ampack Carrying Cases, Rec Tape Accessories)  
CASSETTE: (Victor Co. of Japan)

Musical Records Co.  
2958-2960 W. Pico Blvd.  
Valentin Velasco 737-0937  
(Musart, Peerless, Eco, Rex)  
TAPE: (Musart, Peerless)

Pep Record Sales, Inc.  
3009 W. Pico Blvd.  
Ronald Ricklin 731-8565  
(Amazon, Angelo, Arhoolie, A/S, Audio Fid, Blue Creek, Biograph, Blues Classics, Bo Caedmon, Chalet, Chart, C.M.S., Comet, C Double-Shot, Douglas, Dyer-Bennett, Ete Ethereal, Everyman, Experience-Anon., Fw Folkways, 49th State, Four Corners, GNP scendo, Grit, Historical, Honor Brigade, J Kapp, Kanaka, Lookup, Lyricord, Makaha, sic Disc, Mediterranean, Newhall, Newn Notable, Ovation, Pickwick, Plantation, Pro 3, Radnor, Ranwood, Republic, Royal Ar ican, R.P.R., Sharmley, S.S.S. Int., Stop, Su hill, Tahiti, Turnabout, Vanguard, Viking, Waikiki, Whiz, Wizard)  
TAPE: (C.T.I., Deutsche-Grammophon, Do Shot, Kapp, Pickwick, Plantation, Polydor, I ect 3, Ranwood, S.S.S. Int., Sun, Tahiti V guard)

●Record Merchandising  
2580 W. Pico Blvd.  
Sid Talmadge 385-9161  
(Avco/Embassy, Duke, Peacock, Cornm wealth/United, Little David, Original Sou All Platinum/Stang, White Whale, Era/hal Tiger, ESP, Canyon, Brunswick, Pzazz, W bound, Metromedia, Scepter/Wand, Nones Sun, Jamie/Guyden, A&M, Elektra, Jub Josie, Musicor, Perception, Paramount, - Steed, Viva, Savoy)

●Transcontinental Dist. Corp.  
15500 So. Main Street  
(Gardena)  
Frank Holland 321-6260  
(Banyan Tree, Blue Thumb, Buena Vis Disneyland, Jad, London, London Group, 1 gether, Forward, Dictation Disc, Flick City, G Crescendo, Hickory, RCA, Take 6)

●Oakland—(415)  
Chatton Distributing Co. Inc.  
2517 San Pablo Avenue  
Robert M. Chatton 444-5677  
(A.G.P., A. J. P., Abet, Amy, Arhoolie, Atlant Bell, Blue Classics, Burt, Century, Chang Creed, Cressent, Cross, Cye, Cyclone, D, D.J.M., Dade, Delmark, Dial, Dore, Dougl ELF, Enterprise, Excello, Flashback, Focus, Fd Corners, Goldwax, Hi-Oldies, Highland, Insta Jewel, Kapp, Legrand, Living, Language, I pine, M.F., Mala, Mem-O-Ree, Money, Mutt, Jeff, Nasco, Nashboro, New Voice, Old Tim Page One, Paula, Philly Groove, Plantatio Pzazz, Radnor, Raglan, Ranwood, Republic, R Ronn, Rosemart, Royal American, SSS, S Francisco, Satelite, Seven B, Specialty, Sta Sun, T.A., Tiare Tahiti, Treasure Chest, Val Windfall)  
TAPE: (Atlantic, Living Language)

●H.R. Basford Company  
800 Mariposa Street  
Jack Solinger 626-5494  
(Archive, Archive of Folk Music, Archive Gospel Music, Archive of Piano Music, Cet Concert Disc, connoisseur Society, Count point, Composers Recordings, Deutsche Gra mophon, Everest, Music Minus One, Pickwic Seattle Symphony, Scala, Tradition Heliod Avant Garde, Bluebook, Chisa, Dance Aloi Douglas, Embryo, First Amendment, Forev GPA, GRC, Hi Fi, Mainline, Moonshot, Bl Horizon, Dynamite, Original Sound, Peaco Phil-La-Of-Soul, Pickwick, Polydor, Power, Pr ident, Rare Earth, Revue, Scepter, Shami Shout, Songbird, Soul, Sue, Sundi, Tamla, Tc dlin' Town, Tradition, Uni, United, VIP, War Weed, Work, A&M, Abnak, Action, Arctic, Ast Backbeat, Bang, Bethlehem, Beverly Hi Caila, Cap City, Century City, Clims, Colossi Commonwealth United, Constellation, Cotillik Dakar, Dionn, Drew, Duke, Event, Excel, Ex Federal, Firebird, Gamble, Gordy, Groovy, Ha Hob, I.A., Independence, Innis, Jamie, Jani Canyon, Direction, Soul Clock, Jaskan, Jetst Kasma, Kent, Keymen, King, Laurie, Lucky : Markee, Mar-V-Lus, Maxwell, Modern, Lilesto Moira, Mosoul, Motown , Neptune, Nike, Nc One-Der-Ful, Original Sound, Peacock, Pepp Phil-La-Of-Soul, Phoo, Plamie, Polydor, Pow



PROMOTION  
SALES & SERVICE  
DISTRIBUTING  
THE HITS

STAN  
THE RECORD MAN

(HITMAKER OF THE SOUTH)

STAN'S /728 Texas Street/Shreveport, Louisiana/(318) 422-7182

(Con't on next Page)



# NO. 1 Distributor in the TRI-STATE AREA



17 Salesmen  
5 Promotion Men  
+  
23 Years Of Experience

# ALPHA

DISTRIBUTING CORP.

20 West End Ave., New York, N.Y. 10023 (212) 586-6200

Record Distributors

•NARM-MEMBER

**H. R. Basford (Cont.)**

Rare Earth, Renee, Revue, Rocker, Runway Five, Salem, Scepter, Scram, Shamley, Shout, Songbird, Soul, Spar, Startime, Steady, Sue, Sundi, Sureshot, Tamla, Teardrop, Thrush, Toddlin' Town, Top & Bottom, Trip, Uni, Vent, Vibration, VIP, Virgo, Wand, Westbound, Whiz, York)

TAPE: (A&M, Astro, Bluebook, Blue Horizon, Century City, Chisa, Cotillion, Dakar, Deutsche Grammophon, Embryo, Forever, Gordy, Janus, King, Laurie, Modern, Motown, Original Sound, Polydor, Rare Earth, Scepter, Soul, Sue, Tamla, Wand, Weed)

•Capitol Records Dist. Co.

680 Beach Street

Jim Mazza 771-3210

(Angel, Apple, Capitol, Colossal, Crazy Horse, Fame, Harvest, Invictus, KEF, Melodiya, 1-2-3, Seraphim, Tower)

TAPE: Angel, Apple, Capitol, Harvest)

•Columbia Records Sales

Wharfside, Suite 311, 680 Beach Street

Bill Shaler 771-8550

(Columbia, Barnaby, Blue Horizon, Date, Epic, Fillmore, Gazette, Harmony, Kinetic, Odyssey, Okeh) (Masterwork Audio Products)

•Eric—Mainland Dist.

645 Bryant Street

Bill Wieland 989-6286

(Ampex, Abbott, Alshire, Alston, Atco, Audio Fidelity, AudioRarities, Amsterdam, Alegre, Bluestime, B.T. Puppy, Carla, Creed Taylor, Dynamo, DeLuxe, Earl, Enterprise, Flying Dutchman, Folkways, Generation, Golden, Gross, Gospel, Hollywood, Jad Josie, Jubilee, Karen, Klondike, Koko, Laff, Lizard, Look, Mainstream, Mr. G, Mobile Fidelity, Monitor, Monument, Mothers, Musicor, Mardi Gras, Notable, Nashville, Oracle, Pompeii, Pentagram, Perception, Project-3, Public, People, Prestige, Raw, Roulette, Sound Stage-7, Savoy, Skye, Stanyan, Starday, Stax, Swampfire, Studio-10, Tico, Thunderbird, Vortex, Volt, Vesuvius, Yew)

TAPE: (Ampex, Atco, Cascom, CTI, Josie, Jubilee, Laff, Prestige, Monitor, Savoy, Volt, Enterprise, Thunderbird)

Festival Record Distributors

161 Turk Street

Ed Kewmwea 775-3434

(Ace of Clubs, Alector, Amadeo, Alngelicum, Apon, Arab Tunes, Avoca, B&F, Balkan, Bareneiter, Bruno, Cambridge, Canary & Parakeet, Children's Rec. Guild, Colonial, Colosseum, Con-

**Festival Record Dist (Cont)**

versaphone, Dana, Dyer-Bennet, Eterna, Eurotone, Folkraft, Gregorian Institute, Harmonia Mundi, Haydn Society, Helios, IMF, Kismet, Lyrichord, Music Library, Nina, Russell, Spoken Arts, Standard, Steno Speed, Stinson, Tikya, Ultraphone, Young People's Recs)

•Liberty/U.A. Dist. Co.

680 Beach Street

Jack Mesler 775-5353

(Blue Note, Imperial, Liberty, Minit, Soul City, Sunset, Veep, World Pacific Jazz, United Artists)

TAPE: (Liberty/United Artists, Sunset)

•Melody Sales Co., Inc.

324 Harbor Way

Al Bramy 589-5667

(A.B.C., Accent, All Platinum, Amos, Apt, Aquarius, Athena, Bluesway, Boo, Buulu, Cadet, Caedmon, Carole, Challenge, Checker, Chess, Contemporary, Command, Crescendo, Crewe, Debut, De Lite, Dunhill, Elektra, Early Bird, E.S.P., Evolution, Fantasy, G.R.T., Good Time Jazz, Halycon, Head, Hickory, Hobbit, Id, Intrepid, Impulse, Jansco, Juno, LHI, Loma, O.K.B.I., Metromedia, Monmouth-Evergreen, Movietone, Nonesuch, Peachtree, Probe, Oro, Reprise, Riverside, Soul Clock, Stang, Super-scope, Syntonic Research, Talent, Tangerine, T.R.X. 20th Century Fox, Virtue, Warner Brothers, Zodiac, Dandelion)

TAPE: Same as above.

Music West

460 Talbert Street

(Daly City)

M.B. Kirk 467-5800

(Amaret, Amazon, Bach Guild, Bayou, Blue Fox, Blue Rock, Burdette, Candide, Cardinal, Chart, Emery, Everyman, Fiesta, Fontana, GWP, Limelight, Mercury, Midnight Sun, Peach Tree, Pete, Philips, Pulsar, Share, Silver Fox, Smash, Stop, Vox, Wayside, World Series, Cap Latino, Discos Columbia, Discuba, Eco, Falcom, Musart, Orfeon, Peerless, Rex, Sunglow)

TAPE: (All Labels)

•Transcontinental Distributing Corporation

868 Cowan Road

Bob Ellis 697-6800

(Blue Thumb, Brite Leaf, Buddah, Buena Vista, Chapter One, Chart, Cobblestone, Coliseum, Curtom, Deram, Decca, Diamond, Disneyland, Doubleshot, Garpax, 49th State, Hi, London, London American, Parrot, Press, RCA, Request, Seville, Shell, Spinn, Splash, SPQR, Skye, Terrace, Tribe)

**COLORADO**

**DENVER—(303)**

ABC Record and Tape Sales Corp.

10625 East 47th Avenue

Howard Long 343-7822

(ABC, Dunhill, Command, Bluesway, Impulse, Riverside, Tangerine)

TAPE: (Ampex, G.R.t.)

Boyd Dist. Co. Inc.

1400 West Third

Joe Caravana 222-7701

(Angel, Capitol Records, Crazy Horse, Fame, Harvest, Invictus, Melodiya, 1-2-3, Seraphim)

TAPE: (Apple, Angel, Capitol, Fame, Harvest, Invictus, Melodiya, Seraphim)

•Craig Corp.

4959 Colorado Blvd.

Marty Bendik, Phil Noble 399-0434

(Barnaby, Blue Horizon, Columbia, Date, Epic, Fillmore, Gazette, Harmony, Immediate, Kinetic, Masterworks, Odyssey, Okeh)

TAPE: Barnaby, Blue Horizon, Columbia, Date, Epic, Fillmore, Gazette, Kinetic, Immediate, Masterworks, Odyssey, Okeh)

•Davis Sales Company

4555 Kingston Street

Larry Davis, Bill Davis 344-0880

(A&M, Atco, Atlantic, Crewe, Dot, Liberty, Imperial, World, Pacific, Soul City, London, Parrot, Hi, Monumnet, Musicour, StaxVolt, Scepter, Wand, Hob, Sunset, Ranwood, S.S. International, Sun, Plantation, Reprise, Warner Brothers, Vanguard, RCA, Enterprise)

TAPE: A&M, Ampex, Atlantic-Atco, Stereotape, GPT, ITCC, Liberty, Paramount, Pickwiche, RCA S.S. International, Scepter-Wand, Warner Bros, Reprise, Stax-Volt, Vanguard)

Pan American Record Supply

77 Kalamath Street

Lou Oxman 255-2021

(Accent, Alvina, Artic, Ashley, Bethlehem, Black Prince, Blue Angel, Blue Fox, Blue Note, Boo, Cadet, Cadet Concept, California, Canyon, Checker, Chess, Childrens Record Guild, Colonial, Connoisseurs Society, Contemporary, Conversaphone, Crescendo, Dana, Deluxe, De Place, Diamond, Dictation Disc, Dionn, Double Bayoo, ESP, Fantasy, Finer Arts, Folkways, 49th State, Galazy, Good Time Jazz, EXP, Gross, Happy Tiger, Head, Hickory, Hollywood, Jamie, Jay Jay, Jewel, Josie, Jubilee, JWS, King, Klondike, Laff, Living Language, Living Literature, Longhorn, Look, Midnight Sun, Mobile Fidelity, Mowhawk, Milestone, Nashville, Neptune, Nina, Notable, Ovation Owl, Paula, Pentagram, Phil La of Soul, Prestige, Pzazz, Republic, Request, Ronn, Sermon, Silver Fox, Society for Forgotten Music, Soft, Soul Clock, Specialty, Standard, Stop Sundi, Voice of Country, Wet Soul, Young Peoples Records)

TAPE: (All tape lines)

•Transcontinental Dist. Corp.

1111 So. Platte River Drive

Earl Woolf, Marc Bertone 733-7203

(Allegro, Abnak, Amaret, Amos, Ampex, An Ascot, Audio Fidelity, Award Artists, Bany Tree, Bell, Blue Rock, Blue Thumb, Bl Verve, Brunswick, Buddah, Calla, Comm wealth United, Colossus, Century City, C gress, Chart, Cobblestone, Cotillion, C.T.I., C tom, Dakar, DGG, Decca, Delite, Directio Doubleshot, Coral, Elektra, Embryo, Emerc Event, Evolution, Fontana, Fiesta, Flick Dis Gordy, Forward, Forewer, GRT, GWP, Heritag Hobbit, Hot Wax, Independence, Internatio Artists, ID, ITCC, Jad, Kama Sutra, Kapp, Le LHI, Lizard, Lil Darlin, Little David, Limeli Life, Lyra, Mainstream, Mala, Metromed Mercury, MGM, Mira, Mirwood, Motown, MT Nonesuch, Original Sound, Pace, Page Or People Philips, Philly Grove, Polydor, Pula Rama Rama, Remember, Revue, Riot, Roulet Royal American, Shamley, Shelter, Sky Smash, Solid State, Soul, Stang, Stereo T mension, Studio 10, Stylist, Sundown, S Talent Assoc. Bell, Tamla, Tico, T Neck, TR Uni, United Artists, Vance, Viva, Vault, Vee Venture, Verve, Verve Folkway, Verve Tren Vocalion, Westbound, White Whale, Weed)

TAPE: (Same as above).

**CONNECTICUT**

**EAST HARTFORD — (203)**

•Columbia Records Sales

100 Constitution Plaza, Room 600

Stephen J. Capone 522-7151

(Columbia, Epic, Date, Odyssey, Harmo Barnaby, Okeh Records and Tapes, Mast work Phonographs, Radios & Tape Recorders)

•Liberty/U.A. Dist. Co.

477 Conn. Blvd.

Ron Orsini 528-9511

(Liberty, United Artists, Blue Note, Imperia Minit, Solid State, Sunset, World Pacific, Worl Pacific Jazz)

TAPE: (Liberty, Sunset, United Artists)

Seaboard Distributors

275 Park Ave.

Marv. Ginsburg 289-9361

(Amaret, Amos, Atco, Atlantic, Bang, Be Brunswick, Cadet, Certron, Checker, Ches Colossus, Commonwealth-United, Cotilio Dakar, Dial, Disneyland, Duke, Elektra, Er bryo, Enterprise, Fantasy, GRT, Gamble, I trepid, Juno, LHI, Nonesuch, Ode 70, Orig inal Sound, Page One, Peacock, Philly Groov Plantation, Ranwood, Roulette, SGC, SSSI, Sa Francisco, Savoy, Skye, Specialty, Stax, Stan Sun, Talent Associates, Vista, Volt, Vorte White Whale, Windfall)

•Transcontinental Distributing Corporation

734 Tolland Street

Richard J. Godlewski 289-8631

(ABC Paramount, Alshire, Aphrodisiac, AP Archive, Ariel, Avco-Embassy, Bach Guild Bamboo, Bert & I, Bluesway, Bluesway, Blu Thumb, Buddah, Buluu, Caedmon, Calenda Camden, Canyon, Cardinal, Challenge, Char maker, Colgems, Coliseum, Command, Cre scendo, Crewe, Curtom, Delite, Deram Deutsche Grammophon, Dictation Disc Douglas, Dunhill, Dynamo, Dyno, Earth, Era Event, Evolution, Fiesta, Flying Dutchman Fontana, Forward, Four Corner, Golden, Gordy Grecophon, Gregar, Gross, GWP, Harbou Haydn Society, Heliodor, Heritage, Hi, Hickory Hob, Hot Wax, Hour Glass, Immediate, Impulse, Jad, Janus, Jay Jay, Josie, Jubilee Kama Sutra, Kapp, King, Kirshner, Klondike Laurie, Life, Limelight, Living Language Loma, London Group, Loren, Mace, Mair stream, Mercury, Metromedia, MGM, Monito Monument, Motown, Music Guild, Music Minu One, Musicor, Paramount, Parrot, Pavilio Peace, Philips, Pip, Polydor, Poppy, Pos Press, Prestige, Probe, Pulsar, Rare Earth, RC Victor, Reprise-Deity, Richmond, Royal Am erican, Scepter, Scram, Sire, Smash, Smobro Somerset, Soul, Sound Stage 7, Starday Setero Dimension, Stormy Forest, Sue, Supe K, Syntonic Research, Tamla, Tangerine, Tet ragrammation, Threshold, Thunderbird, Neck, Together, Tower, TRX, 20th Centur Fox, United Talent, Vanguard, Verve, Verv Forecast, VMC, Wand, Warner Brothers, West minster, Winro, WPOP, Yew, Young People).

TAPE: (Same as above)

**DISTRICT OF COLUMBIA**

**WASHINGTON, D.C. — (202)**

•Capitol Records Distributing Corp.

1000 Vermont Avenue, N.W.

Reynold Martini 737-3246

(Apple, Angel, Capitol, Invictus, Fame, Trump Seraphim)

General Distributing Co., Inc.

2329 Pennsylvania Avenue (Baltimore, Md.)

(See Baltimore for lines handled)

(Con't. on next page)



**FUTURA-TONE**

DESERVES YOUR ATTENTION

AGGRESSIVE PROMOTIONS

AGGRESSIVE SALES

AGGRESSIVE DISTRIBUTION

SINGLES — LP's — TAPES

**FUTURA-TONE DISTRIBUTORS**

536 Broad Hollow Road

Melville, L.I., New York 11746

(212) 895-8050 — (516) 694-8990

Dave Seidman, V.P.

# To serve you better\*

## from coast-to-coast...



\* better sales -  
better promotion

*LONDON*  
RECORDS®

### now offers 3 factory branches

#### LONDON RECORDS DISTRIBUTING CORP.

39 WEST 25 STREET  
NEW YORK, N.Y. 10001  
(212) 255-8350

Bill Wesen, Branch Manager  
Frank La Rocca, Assistant Manager  
Ed Wolff, Sales & Promotion  
It Friedman, Promotion  
Mel Richmond, Promotion

#### LONDON RECORDS MIDWEST DISTRIBUTING CORP.

6363 GROSSE POINT ROAD  
NILES, ILLINOIS  
(312) 647-0410

Mel Kahn, Branch Manager  
Stan Meyers, Assistant Manager  
Irwin Barg, Promotion

#### LONDON RECORDS OF CALIFORNIA, INC.

1555 WEST ROSECRANS AVE.  
GARDENA, CALIFORNIA  
(213) 770-8200

Mario De Felippo, Sales Manager  
Godfrey Dickey, Administrative Manager  
Tom Ray, Promotion

# Record Distributors

•NARM MEMBER

•Schwartz Brothers, Inc.  
2146 24th Place  
James Schwartz 529-5700  
(A&M, Abnak, Abbey, AGP, Amaret, Amy, Alegre, Amos, Ashley, Atco, Athena, Atlantic, Auto Fidelity, Avant Garde, Bang, Bell, Bethlehem, Boone, Buena Vista, Blue Thumb, Cadet, Caedmon, Chariot, Chart, Checker, Chess, Community, Compass, Contemporary, Crescendo, DBT, Deutsche, Gramophone, Dial, Dictation Disc, December, Direction, Disneyland, Double Shot, Douglas, Dynamo, Elektra, Event, Evolution, Fame, ESP, Fontana, Four Corners, 49th State, Forward, Gamble, Golden, Good Time Jazz, GRT, Gordy, GWP, Helidor, Hickory, HIP, Holiday Inn, Hollywood, Independent, Jewel, Kapp, King, Laurie, Living Language, Loma, Mainstream, Mala, Mardi Gras, Mercury, Metromedia, Milestone, Monument, Motown, Mr. G, Musicor, Nashville, New Voice, Nonesuch, PIP, Nugget, Original Sound, Philly Groove, Paula, Page One, Philips, Plantation, Pickwick, Polydor, Project 3, Reprise, Revue, Riot, Roulette, Ronn, Shout, Side-walk, Show Town, Shamley, Skye, Sound Stage 7, Smash, Soma, Soul, Stereo Diminution, SSS International, Stax, Starday, Straight, Stereo Fidelity, Stereodites, Sue, Tamla, Tico, Time, Tower, TRX, Twinnight, UNI, USA, Up Front, Up Town, Vanguard, Va, Vault, Venture, Verve, VIP, Volt, Warner Bros., White Whale, Wing World Series, Young People)  
TAPE: (A&M, Atco, Atlantic, Bang, Bell, Buena Vista, Cadet, Chart, Checker, Chess, Crescendo, DGG, Direction, Disneyland, Double Shot, Dyna-voice, Elektra, ESP, Fontana, Gamble, Gordy, Goldwax, Heartwarming, Hickory, Hip, Hob, Kapp, Laurie, King, Limelight, Living Language, Loma, Mainstream, Mercury, Metromedia, Monument, Motown, Musicor, New Voice, Original Sound, Paula, Philips, Philly Groove, Plantation, Project-3, Reprise, Roulette, Scepter, SGC, Skye, Smash, Soul, Sound Stage 7, Starday, Stax, SSS International, Tamla, UNI, Vanguard, Vault, Verve, Volt, Warner Bros., White Whale)

## FLORIDA

**HIALEAH — (305)**

**Tone Distributors Inc.**  
495 S.E. 10th Ct.  
Henry Stone 888-1685  
(Atlantic, Atco, A.B.C., Motown, Tamla, Gordy, Warner Bros., Reprise, M.G.M., Verve, Chess, Checker, Cadet, UNI, Kapp, Stax, Volt, Command, Proble, London Group, Scepter, Wand, Duke, Dunhill, King, Laurie, Douglas, Amy, Mala, Bell, Roulette, Kent, Modern, Date, Al-

## STONE DISTRIBUTOR Con't.

ston, Marlin, G.W.P., Bang, Diamond, Impulse, Jewel, Paula, Vanguard, Dial, All Platinum, Jad, Turntable, Old Town, Original Sound, Westminster, Tone Latino, Tico, 20th Century, Tangerine, Amos, Straight, Evolution, Stereo Dimension, Gamble)

## MIAMI—(305)

**Campus Record Distributing Corp.**  
7250 N.W. 36th Avenue  
Joe Stanizone 691-3140  
(A&M, Ode '70, Abbott, Golden, Yew, Abbey, Allegre, Altair, Alshire, Amaret, American International, Ampex, Apocalypse, Audio Arts, Audio Fidelity, Baja Productions, Banana, Banner, Beverly Hills, Blue Angel, Blue Thumb, Shelter, Bond, Bright Orange, Power, Buddha, Cobblestone, Curtom, Hot Wax, Eleuthra, National General, Kama Sutra, Pavillion, Royal American, Super K, Sussex, Smobro, Pace, T Neck, Team, Thomas, Symbolic, United Talent, Canyon, Carib, Cassette Communications, Celebrity Circle, Century City, Forever, Centron, CGC, Challenge, Crewe, Chalet, Chanson, Chery-laine, Chytown, Comm'wth United, Cotillion, Bashie, Dakar, Embryo, Lamp, Moira, Shama, Trip 3000, CTI, Disneyland, Dot/Paramount, Double Shot, Whiz, Doubletalk, Earth, Life, Peace, Elbejay, Environment, Fabri, Forward, Together, Winro, Gemini, Generation, Gentry, Gerim, Great American, GRT, Guy Jim, Happy Tiger, Era, H & W Imagineering, Heritage, Hometown, HSH, Itco, Ivanhoe, Jad, Turntable, Jamie Guyden, Arctic, De Place, Dionn, L.A. Louisiana, Lundy, Phil L.A. of Soul, Rujac, Sundi, Top & Bottom, Vent, Janus, Anvil, Westbound, Jay Gee, B.T. Puppy, Gross, Josie, Jubilee, Raw, Juno, Kangi, Kashe, Klondike, La Salle, Le Bill Music, Le Cam, Charray, Soft, Lemon, Living Language, Livingston Audio, Malynn, Highland, Money, Map City, Mercury, Blue Rock, Emarcy, Fontana, Intrepid, Limelight, Mod, Peachtree, Philips, Pulsar, Smash, Virtue, Wing, Metro-media, Monumnet, Rising Sun, Sound Stage 7, Musicor, Ariel, Downbeat, Dynamo, Tamboo, Neptune, Nico, Notable, Open, Oracle, Big Yellow, Magic Carpet, M.A.I., Ovation, Peacock, Back Beat, Song Bird, Sure Shot, Pentagram, Perception, Pete, Plaza, Poison Ring, Pompeii, Post, Proverb, Gospel Corner, Raftis, Ranwood, Rnefro, Republic, Roulette, Calla, R P R, Saadia, Scram, Seven B, Alon, Lanor, Tune-Kel, S.S.S.I., Amazon, Glo-Whiz, Honor Brigade, Minaret, Blue Fox, Plantation, Share, Silverfox, Sumpter, Sun, Playground, Wet Sould, Midnight Sun, Double Bayou, Black Prince, Springboard, Up Front, Steady, Stereo Dimension, Athena, Evolution, Stop, Sugar Hill, Summitt, Aquarius, Duo, Dee GDEE£ Giant, Hit Sound, Lock, Tories, Zodiac, Sundown, Superscope, Tarpon, Tear Drop, Tee Off, Tico, Fania, Tonsil, Trip Universal, Trent Town, Twinnight, Vault, Vee Eight, Vesuvius, Volume, Vulcan, Word).  
TAPE: (A & M, Ampex Group, Atlantic/Atco Group, Capitol, Carib, Cascom (Cassette Communications), Columbia Group, Decca Group, Disneyland, Ethnic Group, G R T Group, Josie/Jubilee Group, Liberty//United Artists, Little David, Modern/Kent, Motown Group, Paramount/Dot, Plydor, RCA, Scepter/Wand, Stax/Volt Group, Warner Bros./Reprise, Mercury Group)

•Capitol Records Dist. Corp.  
7425 N.W. 48th Street  
Jerry Brackenridge  
(Apple, Capitol, Angel, Seraphim, Invictus, Fame, Trump)

•Columbia Records Sales  
13145 N.W. 45th Avenue  
Bob Beasley 685-5631  
(Columbia, Epic, Odyssey, Okeh, Barnaby, Blue Horizon, Date, Fillmore, Gazette, Kinetic)

•Decca Dist. Corp.  
2452 N.W. 77th Terrace  
Carmen Larosa 691-4816  
(Berlitz, Bravo, Brunswick, Colonial Standard, Coral, Decca, Kapp, MTA, Viva)  
TAPE: (Berlitz, Vravo, Brunswick, Colonial Standard, Coral, Decca, Deram, Kapp, London, Parrot, Viva)

•Liberty/U.A. Record Dist. Co.  
561 N.E. 79St. Suite 235  
Kenneth McAdams, Tom Sgro 759-1678  
(Ascot, Blue Note, Dolton/Liberty, Imperi Liberty, Minit-Minit/Gospel, Sunset, Solid Sta Soul City, Taib Spinners, Unart, United Artis UA International, UA Latino, Veep/Veep Gosp World Pacific Jazz, World Pacific)  
TAPE: (Liberty, United Artists)

**Music Sales of Florida, Inc.**  
2450 N.W. 77 Terrace  
Donald C. Smith 691-0340  
(Accent, Audio Fidelity, Audio Rarities, Boor Caedmon, Canaan, Carole, Coliseum, Conte-porary, Crescendo, Deram, Dooto, Elektra, Fa-tasy Fax, Flick City, Galaxy, GNP, Good Tir Jazz, GRT, Hickory, International Artist, Kara Laff, London, London Group, Little Darlin, L-ing Language, Mr. G., Mainstream, Mileston Mira, Nonesuch, Parallax, Prestige, Project Riot, Skye, Soma, Stereodities, Take 6, TF Turnabout, Vox, Word)  
TAPE: (Ampex, Capitol, Decca, Dooto, GF ITCC, Liberty, N.A.L., Stereotape (8track, Op Reel, Cassette)

**Sea Coast Appliance Dist. Inc.**  
3575 N.W. 60th Street  
J.W. Shockey 635-0951  
(Calendar, Colgems, Kirshner, Poppy, Reque RCA, Victrola)

## GEORGIA

**ATLANTA—(404)**

•Capitol Record Dist. Corp.  
1670 N.E. Freeway Access Rd.  
Larry Menetre 636 9408  
(Capitol, Angel, Apple, Invictus, Fame, Ser-aphim, Trump).

•Columbia Records Sales  
35 Executive Park Dr.  
Don Dempsey 631-4271  
(Columbia, Epic, Barnaby, Date, Fillmore, Gazette, Kinetic, Harmony, Odyssey, Okeh).

•Decca Distributing Corp.  
2231 Faulkner Road N.E.  
Kent Ortman 636-3028  
(Berlitz, Brunswick, Caedmon, Coral, Decca London, MTA, Standard, Colonial, Viva/Bravo, TAPE: (Berlitz, Brunswick, Coral, Decca, Lon-don, MTA, Viva/Bravo)

•Godwin Distributing Company  
1270 Tacoma Drive, N.W.  
Arthur D. Godwin 351-5110  
(A.G.P., Amaret, Amos, Amy, Aquarius, Aurora, Bamboo, Bell, Beverly Hills, Blue Fox, Blu Rock, Blue Thumb, Challenge, Chisa, Colossus Congress, Cotique, Crewe, Dooto, Doubl Bayou, Elf, Era, Event, Fantasy, Fontana, Gal-axy, Gamble, Goldwax, Gordy, Gospel, Hickory, Hob, Intrepid, Ivanhoe, Jad, Janus, Laurie, Limelight, Little David, Loma, L.H.I., Mace Mala, Mercury, Metromedia, Midnight Sun, Minaret, Motown, Music Land, Page One, Para-mount, Philips, Philly Groove, People, Pulsar, Reprise, Revue, Regent, Rare Earth, Savoy, Scepter, Sharp, Smash, Shamley, Soul, Spe-cialty, Stop, Sun, Steady, T.A., TRX, Tamla Tetragrammation, Toddlin Town, Turntable U.N.I., V.I.P., Venture, Wand, Warner Bros. Wayside, West Bound, Wet Soul, White Whale Dot, Paramount, Steed).  
TAPE: (Ampex, Canaan, Capitol, Columbia Decca, Dooto, Epic, Fantasy, Fontana, GRI Grody, Gross, Galaxy, Heart Warming, Hob ITCC, Ivanhoe, Jay-Gee, Josie, Limelight, Mid-night Sun, Mercury, Metromedia, Modern Motown, Nal, Paramount, Philips, Pickwick People, RCA, Rare Earth, Reprise, Raw, Sacred Scepter, Skylite, Smash, Soul, Sun, Tamla Wand, Warner Bros., Seven Arts, Vivid Sound Wet Soul, Word, Blue Fox, Double Bayou, Lib-erty, United Artists, Little David, Coral, Bruns-wick, Gospel, Savoy)  
ACCESSORIES: Carrying Cases (Ampak, Lebo Camel Mounts, Stereo Lock Mounts, Head Cleaners, Blank Loaded Tape (Basf)

(Con't. on next page)



## HOT LABELS

## HOT DISTRIBUTOR

## HOT BREAK-OUT MARKET

# STONE

## DISTRIBUTORS INC.

495 South East 10th Ct., Hialeah, Fla.

(305) 888-1685

HENRY STONE

MILT OSHINS—DAVE BENJAMIN

## HAPPY ANNIVERSARY

## CASH BOX

### NATIONAL HIT BUILDERS

- ☆ TOP SALES
- ☆ TOP PROMOTION
- ☆ TOP SERVICE

**ERNIE LEANER — BILL LEANER**

Promo Men: LEROY PHILLIPS—TONY LEANER—MIKE ALLEN

## UNITED RECORD DISTRIBUTORS, INC.

1827 South Michigan Ave., Chicago, Ill. 60616

(All Phones: CAIumet 5-6605)

# National Tape Distributors, Inc.

**THE  
UN  
CONGLOMERATE**

*Music is our only business.*

*No insurance companies, mortgage companies, theatres, slide projectors, health and beauty aids, drug stores, transmission repairs or nuts (maybe) and bolts.*

*And . . . we're more than just tape . . . much more.*

*We're NATIONAL TAPE & RECORD, INC. . . . six branches in Milwaukee, Linden, N. J., Houston, Atlanta, Los Angeles & San Francisco, serving our customers nationwide with a full spectrum of recorded music products.*

*We're CALIFORNIA RECORD DISTRIBUTORS, MERIT DISTRIBUTING CORPORATION, HITSVILLE, INC., and UNITED TAPE CORPORATION in L. A., MELODY SALES in S. F., B & K DISTRIBUTORS in Dallas and Oklahoma City, and STEREO SOUTH in Atlanta . . . independent distributors, totally autonomous, with the best labels in the country.*

*We're VAULT RECORDING CORPORATION, VAULT PUBLISHING (BMI) and HOOVER PUBLISHING (ASCAP) . . . and VAULT RECORDING STUDIO.*

*We're a music business run by music people, namely, (tactfully computerized in alphabetical order) Al Acua, Chuck Becker, Al Brame, Lon Brame, Stu Burnat, Bill Burton, Toby Dresser, Gary Drexler, John Fisher, Bob Fleck, Ted Fullmer, Bob Gerstlauer, Shannon Hanby, George Jackson, Ralph Kaffel, Cliff Keeton, Mike King, Marty Kupps, Greg Lewerke, Stan Lewerke, Bob Mercer, Pete Moreno, Bill Monlas, Eric Paulson, Bill Pieper, Gene Reske, Ronnie Richardson, Taffy Rogers, Frank Rohloff, Larry Rosmarin, Tom Suims, Spike Spiefel, Stella Terr, Jim Tiedjens, Paul Tullis, Bob Ursery, Tony Valerio, Marley Waak, Sam Wallace, Bob Well, James (Sunshine) Young . . . and The We Five.*

## **CORPORATE OFFICES**

3515 N. 124TH STREET • BROOKFIELD, WISCONSIN 53005 • (414) 781-2200





## Dome Distributing

Definition of Dome:  
At the top; well rounded

**D**etermination  
**O**rganization  
**M**otivation  
**E**valuation

Consistently applied toward promotion, merchandising, sales, service & satisfaction.

# We Also Get The Job Done



Distributing Corp.  
43-42 10th Street  
Long Island City, N.Y. 11101  
(212) 786-9637  
**BERNIE BLOCK STAN DRYSON**

## Record Distributors

### •NARM MEMBERS

•**Liberty/U.A. Record Dist. Co.**  
1184 Logan Circle NW  
Robert Fisher 355-9350

(Liberty, Imperial, World Pacific, Pacific Jazz, Soul City, Minit, Sunset, Blue Note, Dolton, United Artists, Veep, Solid State)

•**Main Line Records**  
1225 Logan Circle N.W.  
Ed Jarman 351-4150

(A&M, Audio Fidelity, Banner, Command/Prope, Dictation Disc, Elektra, Dandelion, Nonesuch, GRC, Golden, Abbott, Gordy, Heartwarming, Kent, Laff, Milestone, Motown, RCA, Radiant, Radnor, Riot/Redd Fox, Soul, Stereo Dimension/Athena, Evolution)

TAPE: (A&M, Audio Fidelity, Capitol, Columbia, Decca, Elektra, Heartwarming, Laff, Liberty, Motown, RCA, Reprise, Riot, Soul, Tamala, United Artists, Warner Bros.)

•**Southland Records Dist. Co.**

1073 Huff Road, N.W.  
Gerald Friedman 351-4821

(ABC, Atlantic, Atco, Cotillion Group, Avco Embassy, Bang, Bluesway, Buddah Family, Cadet, Chart, Canyon, Checker, Chess, Commonwealth United, Crescendo, Curtom, Dakar, Deluxe, Dial, Diamond, Disneyland, Double Shot, Dunhill, Duke, DGG, Enterprise, GWP, Hi, London Group, Honor Brigade, International Artists, Jamie, Jewel, Josie, Jubilee, Kama Sutra, Kapp, Kent, King, Map City, Maxwell, MGM, Mainstream, Monument, Musicor, Original Sound, Parrot, Paula, Peacock, Plantation 7, Polydor, Project 3, Ranwood, Ronn, Roulette, Royal, American, SSSI, Silver Fox, Sound Stage, Starday, Stang, Stax, Sue, Tangerine, T Neck, Twinnight, Vanguard, Verve, Volt, Westminster)

TAPE: (Ampex, Atlantic/ATCO, GRT, ITCC, Jubilee/Gross, Kapp, Original Sound, Project 3, Scepter/Wand, Stax/Volt, Vanguard)

### HAWAII

#### HONOLULU — (808)

•**Craig Corporation**

620 Coral Street  
Carlton Smith, Masao Tanaka 538-6771  
(Columbia, Epic)  
TAPE: (Columbia, Epic)

•**Eric of Hawaii, Inc.**  
2071 South Beretania Street  
Irv Pinensky 946-6522

(ABC Paramount, Dunhill, Elektra, MGM, Pickwick, Polydor, Reprise, Warner Bros., United Artists, Verve, Metromedia, Stereo Dimension, 20th Century)

TAPE: (Dunhill, Elektra, Polydor, Metromedia, Reprise, Warner Bros., United Artists)

•**K & A Distributors**

2320 A King Street  
Don Ayers 941-4485  
(Alshire, Americana Bravo, Brunswick, Coral, Decca, Double Shot, Happytime, MTA, Pete, Stereo Fidelity, Viva)  
TAPE: (Americana, Bravo, Brunswick, Coral, Decca, Double Shot, MTA, Viva)

•**Microphone Music Co.**  
2077 S. Beretania Street  
Ken Kaizawa 946-1488

(Atlantic, Atco, Cadet, Checker, Chess, Commonwealth, Dooto, Disneyland, Dot, Duke, 4 Corners, Golden, Janus, Jamie, Josie, Jubilee, Kapp, Kent, Living Language, Monument, Ranwood, Roulette, Scepter, Stax, Vault, Volt, Wand)  
TAPE: (Atlantic, Atco, Dot, Dooto, Disneyland, GRT Catalog, Jubilee, Kapp, Scepter, Stax, Wand)

•**Music Craft Distributors of Hawaii, Ltd.**

636 Queen Street  
Walter V. Kurokawa 533-1223  
(Bell, Cyclone, Elf, Goldwax, Hotline, Page One, Philly Groove, Windfall, Crewe Challenge, Colossus, Folkways/Scholastic, Grand Award, Command, Movietone, Music Guild, Probe, Satellite, Westminster, Happy Tiger, Era, Hickory, TRX, Jad, King, Bethlehem, Hollywood, Starday, Laurie, Listen and Learn, Monitor, Mercury, Blue Rock, Fontana, Intrepid, Lime-light, Philips, Pulsar, Smash, Music of Polynesia, Original Sound, Polynesian, Prestige, Project 3, Roper, SSS International, Plantation, Sun, Tradewinds, Vanguard)  
TAPE: (Mercury, Fontana, Limelight, Philips, Smash, Original Sound, Project 3, SSS International, Plantation, Sun, Prestige, Roper, Tradewinds, Vanguard)

•**Nylen Bros. & Co. Ltd.**  
820 So. Beretania Street  
Ed Nielsen 538-1171

(A&M, Audio Fidelity, Blue Thumb, Caedmon, Contemporary, Dolton, Era, Fantasy, Galaxy, Good Time Jazz, Gordy, Hi-Fi-Life, Imperial, Lani, Liberty, L.H.I., Makaha, Motown, Music Minus One, Pace, Pacific, Jazz, Soul, Soul City, Sunset, Tamia, U.N.I., White Whale, World Pacific)

TAPE: (Cartridges & Cassettes-A&M, Fantasy, Galaxy, Liberty, Motown, Open Reel-A&M American Airlines, Bluenote, Double Shot, Imperial, Liberty, Ranwood, Reprise, Solid State, Soul City, Veep, Warner Bros., World Pacific)

•**Radio Television Corp. Ltd.**

432 Keawe Street  
Hector H. Venegas 533-2901  
(Ashley, Amaret, Camden, Caytronics, Ciro, rrot, Poppy, RCA, Request, Richmond, Stanyon, Sire, Mother's, Threshold, Treas Toad-Pitt, Victrola)  
TAPE: (Caytronics, RCA, Stereo 8, Cassette)

•**Surfside Hawaii, Inc.**  
1414 Colburn Street, Room 202  
M.E. "Mac" Laris 870-855  
(Capitol, Hana Ho, Lehua)  
TAPE: (Capitol)

### ILLINOIS

#### CHICAGO — (312)

•**ABC Record and Tape Sales Corp.**  
120 King Street  
(Elk Grove Village)  
439-9700

(ABC, Durhill, Command, Bluesway, Implu, Riverside, Tangerine)

•**K.O. Asher Inc.**  
7818 Stony Island Avenue  
K.O. Asher RE1-1741

(Alector, Apon, Archive of Folk Music, Arhoo, Asch, Bartok, Belzona, Blues Classic, Bornal, Broadside, CMS, Caedmon, Cambridge, Callier, Changes, Classic Editions, Compose, Conversaphone, Desto, Dover, Dyer-Benn, Efom, Enrichment, Euphonic, Eterna, Experience, Anonyme, Festival, Folk-Legacy, Folk Lyric, Folkways, GHB, GMS, Golden Crest, Gogorian Institute, Hydn Society, Historical Jazz Crusade, Jazzologie, Lyrichord, MM Mace, Melodeon, Mirro, Monitor, Motivati, Music Library, Music Minus One, Nessa, Ni, Nobility, Old Timey, Olympic, Original Ja, Orion, Pathway, Piedmont, Playhouse, Pr, penium, Qualiton, Raglan, RBF, River Bd, Rutgers University, Shakespeare Society, Sd, Southland, Spivey, Spoken Arts, Spoken Wok, Takoma, Testament, Theatre Master Wor, Tom, Tradition, Virtuoso, Vocab, Vox-Mu, Master Series, Voix de l'auteur, Yazoo)

•**Columbia Record Sales**  
5405 West Touhy  
(Skokie)  
Mert Paul 463-0900

(Columbia, Masterwork, Phonographs, Da, Harmony, Kinetic, Epic, Barnaby, Fillmo, Gazette, Odyssey, Okeh, Blue Horizon)

•**Decca Distributing Corporation**  
425 North Michigan Avenue  
Anthony Ignoffo 337-1100

(Bravo, Brunswick, Colonial, Coral, Decca, G, Star, MTA, Standard, Viva, Vocalion)  
TAPE: (Bravo, Berlitz, Brunswick, Colonial, Coral, Decca, Viva)

•**Liberty/U.A. Distributing Corp.**  
7901 Caldwell  
(Morton Grove)

Robert J. Golinski 478-1133  
(Blue Note, Imperial, Liberty, Minit, Solid State, Soul City, Sunset, United Artists, World Pacific, World Pacific Jazz)  
TAPE: (Liberty/United Artist Stereo Tapes)

•**London Midwest Dist. Corp.**  
363 Grosse Point Road  
(Niles) Mel Kahn 647-0410

(Ashley, Chapter 1, Coliseum, Deram, Hi, London, Parrot, Phase 4, Sire, Threshold, Budda Group, Monument, Sound Stage 7, Vanguard, Pickwick, Living Language, Vox turnabout, Ranwood)  
TAPE: (All Labels)

•**James H. Martin Inc.**  
2419 S. Michigan Ave.  
James H. Martin V12-4440

(London, Parrott, Hi, Deram and all London Group, Vanguard, Cardinal, Monument, Pickwick, Hilltop, Stereo Fidelity, 101 Strings, Bor, Warner, 8 tr. stereo tape equip., 8 tr. & cassette Tape, Mercury, Cassette Units)

•**Royal Disc Dist. Inc.**  
2623 N. Pulaski Rd.  
Kent Beauchamp 342-6600

(Atco, Bang, B.T. Puppy, Fame, International Artists, Jubilee, Josie, Pete, Pompeii, Event, Thunderbird, Time, Shout, Sac, Gross, Vortex, Power)  
TAPE: (Atco, Jubilee, Ampex, Mercury)

•**Seebro Products Co.**  
2416 S. Michigan Avenue  
R. Siegal 842-8221

(Compost, Coronet, Design, Diplomat, Golden Guest Star, Happy Time, Peter Pan, Pickwick, Rocking Horse, Scripture, Spinorama, Tifton, Twinkle, Seebro Record Cases, Seebro Record Racks)  
TAPE: (Scotch, Highlander, Seebro Tap, Racks)

(Con't on next Page)

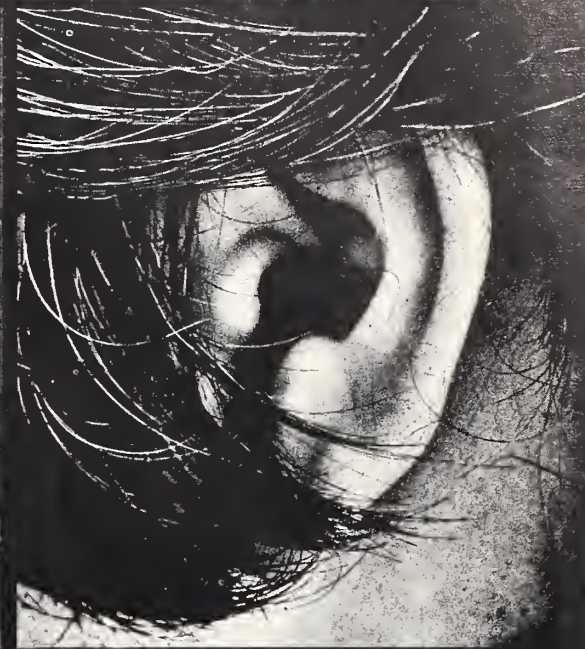

ALL YOU  
HAVE TO DO  
IS LISTEN.



CHES  
CHECKER  
CADET  
CADET CONCEPT.

# Record Distributors

## •NARM MEMBERS

**M.S. Distributing Co.**  
7901 N. Caldwell  
(Morton Grove)  
Ralph Kick 478-1133  
(Amos, Bell, Century City, Challenge, Childcraft, Crewe, Cyclone, Douglas International, Elektra, Elf, Emarcy, Fontana, Four Corners, Goldwax, GWP, Id, Immediate, Kapp, Laurie, LHI, Limelight, Little Darlin', Mercury, Mercury (Classical), Mine, Money, New Voice, Nonesuch, Page One, Peachtree, Philips, Philips World Series, Philly Groove Radnor, Redd Foxx, Smash, Spar, Storyteller, Superscope, Talent Assoc, Tetragrammation, Warner Bros., Exceptions\* Wayside, Windfall, Wing)  
TAPE: (Warner, Reprise, Elektra, Kapp, Nonesuch)

•**Summit Distributors, Inc.**  
7447 No. Linder Avenue  
(Skokie)

•**Jack White, Seymour Greenspan 677-1621**  
(A&M, Acquiarius, All Platinum, Altair, Amsterdam, Anvil, Athena, Audio Fidelity, Black Prince, Blue Fox, Blue Thumb, Blues Time, Brunswick, Canyon, Certron, Chart, Congress, Contemporary, CTI, Delmark, Disneyland, Dot, Double Shot, Duo, Era, Evolution, Fantasy, Fidelity Sound, Fiesta, Flying Dutchman, Galaxy, Generation, Golden, Good Time Jazz, Happy Tiger, Hickory, Janus, Lionel, Little David, Mainstream, Metromedia, Mr. G., Mobile Fidelity, Monmouth/Evergreen, Mothers, Ode '70, Off Spring, Oracle, Parallax, Paramount, People, Pride, Project 3, Revue, Shelter, Silver Fox, Skye, Soul Clock, Stereo Oddities, Stang, Steed, Stop, Top N' Bottom, Uni, Up Front, Uptite, Vault, Vent, Westbound, White Whale, Whiz, Yew, Zodiac)

**TDA Inc.**  
3035 W. 47th Street  
Lee Howard, Mort Ohren 254-4612  
(Abnak, Accent, Alfred, Archive of Folk, Archive of Piano, Artic, Atlantic, Atco, Baroque, Bethlehem, Blue Rock, Boone, Cadet, Cadet Concept, Carole, Cetra, Checker, Chess, Concert Disc, Counterpoint, Diamond, Dionn, Dooto, Enterprise, ESP, Everest Classics, First Amendment, Focus, GNP/Crescendo, GRT, Gordy, Hi Fi, Holiday Inn, Hollywood, Jamie, Jewel, King, Motown, Musicor, Outhouse, Paula, Period, Phil La Of Soul, Pirouette, Plantation, Request, Ronn, Roulette, Scala, Specialty, Soul, SSS International, Starday, Sun, Stax, Tamla, Thunderbird, Tradition, Twinight, Uni, USA, Wvon)  
TAPE: (Same as above)  
EQUIPMENT LINES: (GW, Ross, Mayfair, Peerless, Telex, Tenna)  
ACCESSORY LINES: (Le-Bo, Recoton, Rosewood)

**Transcontinental Distributing Corp.**  
5301 Dansher Road  
(La Grange)  
Max Cooperstein 242-4750  
(American Internation, Blue Book, Cherry, CoBurt, Earth, EJK, Forward, Golden Archive Series, Heritage, Home-Town, Kama Sutra, King Leo, Life, Lyra, Living Language, MGM, Mine, Original Sound, Perception, Poison Ring, Quad, Raftis, Royal American, Stormy Forest, Sue, Tonsil, Together, Verve, Winro, Symbol)  
TAPE: (Living Language, Original Sound)

•**United Record Distributors, Inc.**  
1827 So. Michigan Avenue  
Ernest Leaner, Bill Leaner 225-6605  
(Abet, Afro, Backbeat, Bamboo, Bashie, Cotillion, Creed, Dakar, Duke, Embryo, Excello, Gamble, Hobb, Gamble, Jad, Kent, Laff, Maxwell, Morias, Nashboro, Peacock, Savoy, Scepter, Shama, Songbird, Soul, Tamla, Toddlin Town, Turntable, Volt, Wand, Sound Stage 7)  
TAPE: (Ampex, GRT, ITCC)

## NILES — (312)

•**Capitol Records Distributing Corp.**  
6401 Gross Point Road  
John Conner 647-8338  
(Capitol, Angel, Seraphim, Apple, Invictus, Fame, Seraphim, Trump)

## INDIANA

### FORT WAYNE — (219)

**Tri-State Distributors**  
3434 Broadway  
Cliff Ostermeyer 744-5607  
(ABC, All Star, Alto, Angeltone, Arrawak, Art, Arvee, Atlas, Benevenue, Ballad, Bandbox, Bartell, Baton, May, Uke, Bee, Beltone, Black Gold, Buddy, Bullseye, C & M, Campus, Canary, Cape, Cardinal, Chattahoochie, Contour, Crescendo, Crest, Crossfile, Delden, Desert, DiVenus, Dome, Ebb, Emerald Empire, Enterprise 13, Era, Excello, Fax, Film City, Flick, Flo-jo, Ford, General American, Golden World, Harvard, HiFi, Hit, Hudson, Hugo, Injun, Jamie, Kean, Kenco, Lincoln, Linjo, Longhorn, Lucky Four, Marvella, Mayhams, Mecca, Miracle, Moon, Mosrite, Motif, Motown, Nashboro, Neptune, N-joy, Orbit, Peacock, Petal, Presta, Prime, RSV, Rae-Cox, Ram, Regal, Reno-Smile, Robbins, Randolett, Sabine, Sabre, Sage, Sand, Scloron, Serand, Shalomar, Shee, Sylvania, Sims, Spinix, Starday, Tamala, Tamps, Taylor, Twilight, Vanity, Variety, Vita, Wagner, Wedge, Wells-DeSett, Westport, Paramount, ESP 4 Disk, Fuller Carrie, Chytown, Cobra, Alpha, Goldstar, Greenco, Infal, A.R.U., Jerry Guy, Lanor, Milage, Plato, Pony, Plamie, Raven, Roadrunner, Rimrock, Tomahawk, Wahoo, Will, Zebra, Polly Bee, Visconjon, Star, Blue Creek I.G.L., Ro-Ark, Quinvy, J.R.P. Peachtree, Goldband, Big Beat, Truestone, Tawas, New Frontier, K-Ark, Audio Arts, Archway, Accent, Breeze, Slackbird, Big Sound, Capacity, Carrie, Cavern, Celebrity Circle, Century City, Chante, Conclave, Confederate, Daran, Delite, D.J., Domino, Dot-Mar, Event, Enderver, Five-O, Fabbri, Genesis, Gusman, Hallmark, High Country, Insight, Jalap, Jazz, Jessup, Julmar, K.E.F., K-W, Kangaroo, Kid, Cuzn, Kanwic, Lasalle, Las Vegas, M-Arts, Mickey, Malinda, Millage, New England, Patelfi, Road, PinPoint Public, Plato, R.P.R., Rev, Raydar, Riparia d'Oro, Reena, Rimrock, Silver Seal, Tid-Note, Triode, Three Hills, Valco, Vesuvius, Vida, Zodiac)

### INDIANAPOLIS — (317)

•**Sound Classics**  
333 W. 9th St.  
Louis E. Randle, Sr. 634-2591  
(Buena Vista, Disneyland, Ranwood, RCA, RCA Camden)  
TAPES: (Ampex, GRT, ITCC, RCA)

## LOUISIANA

### NEW ORLEANS — (504)

•**All South Distributing Corp.**  
1924 Lafayette Street  
Henry J. Hildebrand, Jr. 522-1157  
(ABC, Abbott, Abnak, A&M, After Hours, shire, AJP, Amos, Ampex, Amy, Ashley, Ari Athena, Avco Embassy, Backbeat, Bam! Bang, Bell, Bethelhem, Blue Fox, Blue R, Blue Thumb, Bluesway, Caedmon, Car, Challenge, Chisa, Colossus, Command, Cri Crescent, Crewe, Delite, Deluxe, Diamc Dionn, Dooto, Dot, Duke, Dunhill, Enterpr Era, Evolution, ESP, Excello, Fantasy, Font Forward, Golden, Gold Wax, Gordy, GRT, ( pel, GWP, Happy Tiger, Heritage, Hi, Hip, H Hot Wax, Immediate, Impulse, Intrepid, Jar Janus, Jewel, Jerden Jin, King, Ko Ko, Laff Louisiane, Leo the Lion, Life, Limelight, Little David, Living Language, Lizard, Lo London American, Lyra, Mace, Mala, M Map City, Mercury, Monument, Motown, sicor, Music Guild, Nashboro, Original Sou Ovation, Page One, Paramount, Paula, Pai Peacock, People, Philips, Philly Groove, La Soul, Plantation, Polydor, Press, Pr Project 3, Pulsar, Ranwood, Rare Earth, prise, Revue, Riot, Riverside, Ro Jac, Ro Royal American, Savoy, SSS Internatio Scepter, Silver Fox, Sing, Sire, Skylite, Sma Sould, Sound Stage, Specialty, Starday, Sto Forest, Sue, Sun, Stax, Swallow, Ta, Tar Tangerine, Teardrop, Tetragrammation, gether, Tribe, 20th Century Fox, Uni, Up Fr Vanguard, Verve, Verve-Folkway, V.I.P., V Wand, Warner Bros., Wayside, Westbou Westminster, Whit, White Whale, Wind Word, YEW)  
TAPES: (ABC, A&M, Alshire, Ampex, A Atco, Atlantic, Audio, Spectrum, Backb Bamboo, Bang, Bell, Blue Thumb, Blues Buddah, Cadet, Caedmon, Capitol, Check Chess, Colossus, Columbia, Command, Co monwealth United, Crewe, Dakar, De Decca, Deram, Dooto, Dot, Double Shot, Du Dunhill, Enterprise, Era, Excello, Fantasy, F tana, Goodtime Jazz, Gordy, GRT, Hi, Hicck Hob, Humorsonic, Impulse, Jad, Kama Su Kapp, Kind, ILS Language, LaLouisiane, Libe Limelight, LHI, Little David, Living Langua London, London American, Mainstream, M MGMM, Mercury, Metromedia, Modern, M ument, Moonglow, Motown, Musicor, Na boro, New Voice, Original Sound, Paramot Paula, Parrot, Peacock, Phillips, Philly Groc Phil La Soul, Plantation, Polydor, Probe, F ject 3, Ranwood, RCA, Reprise, Roulette, S International Scepter, Sing, Skylite, Sma Soul, Sound Stage, Starday, Sun, Stax, Swall Tamla, Teardrop, Tetragrammation, Thre hold, Time TRX, 20th Century, Uni, Uni Artists, Vanguard, Verve, Verve-Folkway, Vi Volt, Wand, Warner Bros., White Whale, Wit fall)

•**Columbia Record Sales**  
1055 St. Charles Ave-John Hancock Bldg.  
Roger Metting 524-4546  
(Columbia, Epic, Ode, Barnaby, Fillmore)  
TAPE: Same as above

•**Decca Distributing Corporation**  
8135 Earhart Blvd.  
Stanley Layton 486-6026  
(Berlitz, Bravo, Brunswick, Colonial, Cor Chess, Checker, Cadet, Coliseum, Dec Deram, Elektra, Kapp, London, MTA, Neptu Nonesuch, Richmond, Threshold, Volcalic Viva)  
TAPE: (Berlitz, Bravo, Brunswick, Coral, C onial, Coliseum, Decca, Deram, Elektra, Kar London, Nonesuch (Cassettes only) Parr Threshold, Viva)

**McDonald Sales Corp.**  
5000 River Road  
Jay Clapp 733-6653  
(RCA)  
TAPE: (Ampex, RCA)

(Con't. on next pag

Washington, D.C.  
Maryland  
Virginia  
West Virginia

COMPLETE SALES COVERAGE  
INTENSIVE PROMOTION  
RAPID SERVICE

**General**

DISTRIBUTING COMPANY, INC.  
2329 PENNSYLVANIA AVE. • BALTIMORE, MD. 21217  
(301) 669-6411

In ILLINOIS,  
WISCONSIN &  
INDIANA IT'S

**M.S.**  
DISTRIBUTING CO.  
OF COURSE!

FOR PROMOTION & SALES  
(3 Promotion Men) (5 Salesmen)  
OF

RECORDS — TAPES  
MILTON T. SALSTONE, President  
VICTOR FARACI, VP, Gen. Mgr.  
RALPH KNICK, Sales Manager

**M. S. DISTRIBUTING COMPANY**  
7901 No. Caldwell, Morton Grove, Illinois 60053, (312) 478-1133



Our warmest wishes to all our friends at Cash Box upon their 28th Birthday--and to all our friends in the Broadcasting, T.V., Music and Recording Industries --peace, love, and a fulfilling 1970

## THE LETTERMEN



*Tony*

*Jim*

*Gary*

“the lettermen”



EXCLUSIVE PERSONAL MANAGEMENT  
**JESS RAND**

**WILLIAM MORRIS AGENCY, Inc.**  
NEW YORK CHICAGO LONDON HOLLYWOOD



ve got it all.

R. Hard rock. C&W, Pop, Classical.  
ken... it takes all kinds to make a  
or record company. Certron has  
best of other labels and the best of  
undiscovered talent.

We're doing something other record com-  
panies don't do.

We have our own distribution points  
for distributors, rack jobbers, and one-  
stops. Eight regions... four of them with  
Regional Service Centers. Each with their  
own sales, distribution, promotion, and  
shipping departments.

Watch us move our product. And your  
product, too.



*We've got  
it together.*

We're very big on tapes... and getting  
bigger. Certron's Custom Duplication  
Service will take a master... re-master  
or duplicate it... and put it on cartridges  
or cassettes. Then we'll distribute it (if  
you want) under the Certron label... or  
your own label.

**CERTRON CORPORATION MUSIC DIVISION**

1226 16th Avenue South • Nashville, Tennessee

For "Instants" in the West

# PROMOTION EXPLOITATION PROFIT

RON RICKLIN

**PEP RECORD SALES Inc.**

3009 WEST PICO BLVD.  
LOS ANGELES, CALIFORNIA 90006  
(213) 731-8565

LOS ANGELES  
LOS ANGELES  
LOS ANGELES

## MET RICHMOND LATIN RECORD SALES INC.

"The Largest Selection of Spanish LP's in U.S.A."

1637 Utica Ave., Brooklyn, N.Y. Tel: (212) 253-4600  
Branch: 718 10th Ave., New York, N.Y. 10019  
Tel: (212) 265-9480

DAVID LAST, Pres.

If you have Spanish speaking trade in your area we are your answer.

Our vast library of Spanish tapes for LP's is available for lease.

All of our regular priced LP's are now available on 8 track Stereo Cartridges.

Exclusive Distributors of M n R and SEECO RECORDS

a  
natural

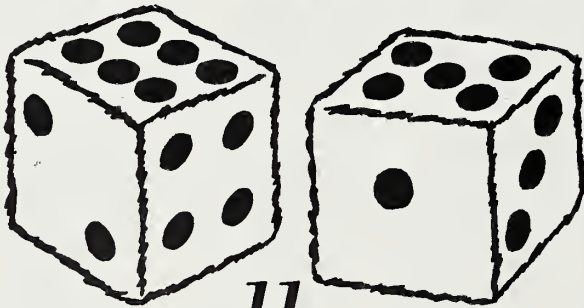

11  
years  
distributing  
the  
HITS

**WENDY  
DISTRIBUTORS**

37 WILLIAM ST., NEWARK, N. J. 07102  
Jerry Winston, Pres. (201) 623-5845

# Record Distributors

## •NARM MEMBERS

**CANTON—(617)**  
Liberty/UA Distributing Corporation  
480 Neponset Street  
(Canton)  
David Elkin 828-6040  
(Blue Note, Imperial, Liberty, Minit, Solid State, Soul City, Sunset, United Artists, Veep, World Pacific).  
TAPE: (Liberty, United Artists)

**Eastco**  
Westwood Industrial Park  
26 Dartmouth St.  
(Westwood)  
Alan Sack 329-3000  
(Colgems, Disneyland, Poppy, RCA, Request).  
TAPE: (Same as above).

## •WOBURN—(617)

**•Transcontinental Distributing Corp.**  
30 Nashua Street  
935-4700  
(AGP, A&M, Accent, Abnak, Alegre, Amy, Alshire, Alston, Amaret, Amos, Arhoole, Artic, Astro, Atco, Athena, Atlantic, Audio Fidelity, Aura, Avant Garde, Avoca, Bang, Bell, Bethelheim, Boquet, Blue Horizon, Bluesville, Brooklyn, B.T. Puppy, Blue Thumb, Buddah, Bunky, Cadet, Calla, Caedmon, Cambridge, Challenge, Checker, Checkmate, Chess, Cobblestone, Columbus, Coliseum, Command, Copley, Cotique, Crescendo, Credo, Crimson, Crossroads, Curton, Dial, December, Delite, Deluxe, Destination, Deram, Diamond, Dionn, Direction, Disneyland, Distinguished, D.J.M., Dore, Double Shot, Dover, Dunwich, Dynamo, Dynovoice, Elektra, Elf, End, Enterprise, Epic, ESP, Era, Evergreen, Evolution, Expo, Fantasy, Fiesta, Focus, Flaming Arrow, FM, Folkways, Fraternity, Galaxy, Gee, Gambel, GNP, Gold Wax, Golden, Gospel, Grand Award, Grecophone, Gross, Harbor, Hi, Hickory, Hob, Go Go, Hip, Hotline, Independence, Jad, Jamie, JCOA, Josie, Jewel, Jubilee, King, Krok, Lib, Editions, Lil Darlin' Liv., Language, LLP, London, Mace, Mainstream, Mala Melanie, Megaphone, Metromedia, Mintemen, Milestone, Money, Moonshot, Monument, Moonglow, Musicland, MMO, Musicor, Nashville, New Voice, Nonesuch, Okeh, MTA, Oldies, Orfeo, Orig. Sound, Pace, Page One, Parrot, Path of Sound, Paula, Philles, Philly Groove, Phil La Of Soul, Plantation, Pioneer, Poppy, Press, Pompeii, Prestige, Project 3, Post, Rejoice, Red Sox, Ranwood, RSVP, Regent, Revue, Rhapsodia, Richmond, Rising Sons, Ronn, Roost, Royal American, Roulette, SSS, Silver Fox, S.G.C., Savoy, Sire, Scepter Sharley, Sharp, Sidewalk, Serville, Shout, Skye, Soma, Specialty, Soundstage, Sphere Sound, Sonologue, Squire, Starday Sharma, Stax, Stereridities, Stereo Dimension, Sunburst, Super K, TRX, Team, Tap, Thunderbird, Tico, Track, Time, Toddlin' Town, Tribe, Tomorrow, Tower, Uni, Union, USA, Vance, Vault, Vegas, Virgo, Vista, Volt, Vortex, Wand, White Whale, Young People, Raw, Strobe, Fund, Twilight, Vent, Aphrodisiac, GWP, Sundi, Blue Pepper).  
TAPE: (A&M, Atco, Atlantic, Elektra, Epic, Fantasy, Gross, Jubilee, Metromedia, Musicor, Okeh, Orig. Sound, Prestige, Project 3, Scepter, Stax)

## MICHIGAN

### DETROIT—(313)

**•ARC-Jay Kay Distributing Co.**  
2211 W. Edsel Ford  
Henry Droz 361-5500  
(ABC, Amos, Ampex, Ariel, Astro, Athena, Audio Fidelity, Avco Embassy, Bluesway, Calendar, Command, Cotillion, Crescendo, Crewe, Dakar, Deram, Diamond, Diamond\*Jim, Dunhill, Douglas, Dynamo, Elektra, Embryo, Evolution, Fiesta, Four Corners, Grsos, GWP, Hi, Impulse, Jay Jay, Jerden, Josie, Kapp, King, Laurie, Legrand, Jubilee, Living Language, London, Loma, Motown, Musicor, Nashville, Nonesuch, Oliver, Original Sound, Parrot, Probe, Project 3, RCA, Renegade, Reprise, Riverside, Roulette, Rust, Soul, Starday, Stereo Dimension, Tetragrammaton, 20th Century Fox, Uni, Warner Bros., Westminster, White Whale).  
TAPE: (ABC, Ampex, Bluesway, Calendar, Command, Cotillion, Dakr, Deram, Diamond, Dunhill, Elektra, Embryo, Fiesta, Four Corners, Gross, Impulse, Josie, Kapp, Laurie, Legrand, Jubilee, London, Musicor, Nonesuch, Original Sound, Parrot, Probe, Project 3, RCA, Reprise, Starday, 20th Century Fox, Uni, Warner Bros.)

**Cadet Distributing Co., Inc.**  
13380 Capital Ave.  
(Oak Park)  
Harry Levin 548-3171  
(Abnak, Specialty, Dooto, M.F., Good Time Jazz, Contemporary, Klondike, Derry, Jet Star, Ovation, Drummond).  
TAPE: (Ampex, Columbia, Capital, Apple, Atco, Atlantic, Liberty, United Artist, RCA, Pickwick, Scepter, ITCC, GRT, Decca, Motown, A&M, Dooto, Epic, Mercury, Philips, Warner Bros., Reprise, Sunset)

**•Capitol Records Dist. Corp.**  
18921 Wyoming Avenue  
Ray Hopper 864-5001  
(Capitol, Angel, Apple, Invictus, Fame, Trump, Seraphim).

**•Columbia Record Sales**  
24681 Northwestern Hwy.  
(Southfield)  
John Kotecki 354-0470  
(Columbia, Epic, Harmony, Date, Fillmore, etc., Odyssey, Barnaby).

**•Liberty/UA Dist. Corp.**  
24123 Greenfield, Suite 208  
(Southfield)  
Kevin Cummings 444-1698  
(Ascot, Blue Note, Imperial, Liberty, Mirific Jazz, Solid State, Soul City, Sunset, United Artists, Veep, World Pacific).  
TAPE: (Liberty, Sunset, United Artists)

**Merle Dist. Co.**  
27222 Plymouth Rd.  
Merle Schneider 255-1360  
(Cabot Language, Golden).

**Merit Music Distributors, Inc.**  
15771 Wyoming Ave.  
John H. Schlee, Gene Silverman 863-91  
(A&M, A Square, Bamboo, Buena Vista, Dance Along, Dearborn, Disneyland, Fraternity, Gordy, Hideout, Hob, Listen to Mira, Mirwood, Monument, Music Mini Oracle, Pepper, Rare Earth, Rising Sun, Terry, Tiffany, Ode, Skye, Sound Stage 7, Steno Disc, Toddlin' Town, Tamla, VJ, Vta, Wand, Wild Bird Songs, Yoga).  
TAPE: (A&M, Gordy, Monument, Motowater/Wand, Soul, Tamla, Rare Earth.)  
CASSETTES: (A&M, Gordy, Motown, Rar Scepter/Wand, Soul, Tamla)

**•Music Merchants, Inc.**  
2950 W. Davison Avenue  
Joe Goleski 883-6565  
(Abbey, Arhoolie, Action, Modern Sound, Avant Garde, Barry, Big Hit, Boo-Ga-La, Blue Rock, Caedmon, Chess, Checker, Cadet Concept, Calla, Carnival, Crimsom, Demco, Dionn, Doubleshot, Duet, Era, ESP Disk, Folkways, Fantasy, First, ment, FSR, Glad Hamp, Groovy, Galaxy, Guyden, Humersonic, Hi-Fi, Jamie, Kin Laff, Life, Limelight, Mainstream, Redd, Metromedia, Mustang, Whiz, Mothers, shot, Magic Touch, Milestone, Okeh, Prestige, Phil La, Proverb, Pzazz, R.S.V.P., Rocker, Satin, Slims, Stax, Star, Twinght, Take Six, Top Dog, Tuba, Vault, Vent, Volt, Weis, Zodiac).  
TAPE: (All Lines)

## MINNESOTA

### MINNEAPOLIS—(612)

**•Capitol Records Dist. Corp.**  
4010 West 65th Street  
Paul Goetz  
(Capitol, Apple, Angel, Invictus, Fame, Seraphim).

**•Columbia Records Sales**  
4570 West 77 Street  
Ron Piccolo 920-8655  
(Barnaby, Blue Horizon, Columbia, Date, Fillmore, Gazette, Harmony, Immediate, Masterworks, Odyssey, Okeh)  
TAPE: (Same as above)

**•Heilicher Bros. Inc.**  
600 Wayzata Blvd.,  
Amos Heilicher, Daniel Heilicher 544-42  
(ABC, Abnak, Accent, Acta, AGP, Alshire, A&M, Amaret, Amazon, Amos, Amy, Anvel (Janus) Aquarian, Ashley, Athena, Atlantic, Avant Garde, Avco Era Award Artists, Bamboo, Bell, Beverly Blue Horizon, Blue Note, Bluesway, Thumb, Bright Orange, Brooklyn, Brur B.T. Puppy, Bunky, Cadet, Caedmon, Ca Camden, Canyon, Carole, Challenge, Checker, Chess, Colgems, Command, munity, Congress, Coral, Cotillion, Crewe, Dakar, Dandelion, Decca, Dial, Diamond, tion, Dot, Double Shot, Douglas, Dunhill, wich, Elektra, Elephant, Elf, Embryo, prise, Era, ESP Disc, Evolution, Fiesta, Flaming Arrow, Flashback, Flying Dutch Folkways, Fontana, Four Corners (Kapp), ble, GNP-Crescendo, Goldwax, Gordy, phone (Fiesta), Gross, GRT, GWP, Happy Head, Hip, Hob, Hobbit, Holiday Inn, Brigade, Hot Line, Immediate, Imperia pulse, Intrepid, Jad, Jamal, Janus, Jerde star, Jewel, Josie, Jubilee, Juno, Kama Kapp (Four Corners), Kent, Kirshner, Klo Laurie, LHI, Liberty, Limelight, Little David, Lorna, Mace, Mainstream, Mala, Me Metrobeat, Metromedia, Minit, Mobile Fi Moonglow, Motown, MTA, Music Guild, Minus One, National General, Neptune Voice, Nonesuch, Oracle, Pace, Pacific Page One, Paramount, Paula, People, P Philly Groove, Pip, Plantation, Polydor, Po Poppy, President, Probe, Proscenium, Rare Earth, Reprise, Revue, Riverside, Ro San Francisco, Scepter, Senate, SGC, Sha Shelby, Shelter, Silver Fox, Smash, S Soma, Soul, Soul City, SSS International, Steed, Stereodimensions, Steroddities, Sundown, Symbolic, TA, Tamla, Tang Tetragrammaton, Thunderbird, Tiffany, Century Fox, Toddlin' Town, Vanguard, Victrola, Vip, Viva, Vocalion, Volt, Vortex, Wayside, Warner Brothers, Westbound, minster, White Whale, Windfall, World P Yew).  
TAPE: (Same as above)



*John*

★ **TOPS IN PROMOTION** ★

★ **SALES** ★ **SERVICE** ★

**IN THE CAROLINAS!**

**SINGLES — LP'S — TAPES**



**Arnold Distributing Co.**

2704 FREEDOM DRIVE — CHARLOTTE, N.C. — (704) 399-9741  
**BERT FLEISHMAN, PRESIDENT**  
**JOHN TOWLES, SALES MGR. — SONNY WOODS, PROMOTION**

# Record Distributors

## •NARM MEMBERS

•**Jather Distributing Corp.**  
**730 Lyndale Ave. No.**  
**Jack A. Taylor, "Bud" Fritz 374-3420**  
 (Audio Fidelity, Bethlehem, Black Gold, Century City, Chart, Commonwealth United, Conversaphone, Delite, Dictation Discs, Fantasy/Galaxy, F.S.R., Federal, Forever, Hickory, International Artists, Jamie, King, Living Language, Musicor, Nashville, Project 3, Dave Rooney, Royal American, Solid State, Speciality, Starday, Stop, Sundi, TRX, United Artists, Veep, Children's, C.R.G. & Y.P.R., Canary & Parakeet Training).  
 TAPE: (United Artists)

•**Liberman Enterprises**  
**9549 Penn Ave. So.**  
**David Lieberman 888-5521**  
 (Bach Guild, Bang Best, Bravo, Buddah, Calla, Cameo, Chairman, Cobblestone, Coliseum, Dot, Felste, 49th State, Four Corners, Garpax, Hi, Kama Sutra, Kapp, Leo, London, MGM, Monument, Parrot, Press, Prestige, Ranwood, Rama Rama, Roulette, Sire, APQR, Sidewalk, Sound Stage 7, T-Neck, Tower, Tribe, Vanguard, Verve, Verve Forecast, Viva)

## KANSAS CITY—(816)

**Choice Records Distributing**  
**321 Southwest Blvd.**  
**Harold Hassler HAI-2540**  
 (Abnak, Chalet, Chart, Chestnut, Era, Happy Tiger, Hickory, Kent, Nashboro, Original Sound, Republic, Royal American, Scepter, SSS International Group, Starday, Sun).  
 TAPE: (Same as above).

## ST. LOUIS—(314)

•**Columbia Record Sales**  
**1144 Hampton Avenue**  
**Bob Van Metre 647-5101**  
 (Barnaby, Blue Horizon, Columbia, Date, Epic, Fillmore, Ode, Okeh).  
 TAPE: (Columbia, Date, Epic)

•**Commercial Music, Inc.**  
**2020 Delmar Blvd.**  
**Alfred L. Chotin 241-8618**  
 (A & M, A/S, ABC, Amaret, Amazon, Ariel, Astro, Audio Fidelity, Bamboo, Bazooka, Blue Angel, Blue Rock, Blue Thumb, Bluesway, Bravo, Brunswick, Certron, Chart, Chisa, Command, Coral, Cotillion, Dakar, Decca, Diamond, Doubias, Dunhill, Dynamo, Embryo, Event, Fantasy, Fiesta, Fontana, Gordy, Gospel, Greco-phone, Hickory, Hob, Honor Brigade, Impulse, Immediate, Intrepid, Ivanhoe, Janus, Jerden, Kent, Lamp, Limelight, Loma, MTA, Mercury, Metromedia, Minaret, Mr. G., Modern, Moira, Motown, Musicor, Original Sound, Pace, Peachtree, Philips, Pip, Plantation, Probe, Project, Ranwood, Rare Earth, Reprise, Riverside, Republic, Savoy, Scepter, Shama, Shelter, Smash, Sould, SSS International, Sun, Swampfire, Tamla, Tangerine, Thunderbird, Toddlin' Town, Tonsil, 20th Century Fox, Twilight, Viking, Vip, Viva, Want, Warner Brothers, Wayside, Weed, White Whale).

•**Liberty/UA Distributing Corporation**  
**1815 Locust Street**  
**Jim Saltzman 621-7171**  
 (Blue Note, Imperial, Liberty, Minit, Solid State, Soul City, Sunset, Talespinners, United Artists, Veep, World Pacific).  
 TAPE: (Liberty, Sunset, United Artists)

•**Roberts Record Dist. Co.**  
**1815 Locust Street**  
**Norman Hausfater 621-7171**  
 (Abnak, Accent, Alston, Amos, Ampex, Amsterdam, Army, Aquarius, Artic, Atco, Athena, Atlantic, Bach Build, Bang, Bell, Bluestime, Buddah, Cadet, Caedmon, Calla, Camden, Candide, Canyon, Cardinal, Challenge, Checker, Chess, Coliseum, Commonwealth, Congress, Crewe, Curtom, Cyclone, De Lite, Deram, Dial, Dionn, Disneyland, Dooto, D.G.G., Dot, Double Shot, Earth, Eiektra, Elf, Era, Everyman, Evolution, Federal, Flying Dutchman, Forward, Four Corners, Fraternity, GNP Crescendo, Gambia, Giant, Golden, Goldwax, GRT, Guyden, Happy Tiger, Heritage, Hi, Hi Fi, Hip, Hobbit, Hot Wax, I.D., Int. Artists, Jamie, Jetstar, Josie, Jubilee, Kama Sutra, Kapp, Karen, K-Ark, King, Kirshner, L.H.I., Laurie, Life, Lyra, London, MGM, Mainstream, Mala, Moon Shot, Monument, Music Factory, Musicland, Nashville, Norman, Nonesuch, Nuggett, Page One, Par T, Pavilion, Paramount, Phil La, Philly Groove, Polydor, Pompeii, Prestige, Press, Pzazz, RCA, R.F., Revue, Ron, Roulette, Royal American, S.G.C., San Francisco, Shamley, Shandy, Shout, Show Biz, Sire, Sidewalk, Smobro, Sound Stage, Starday, Stang, Stax, Stop, Stormy Forest, Spar, Sue, Super K., T.A., T-Neck, Thomas, Threshold, Together, Tower, Tribe, Turnabout, United Talent, Uptown, Uni, Vanguard, Vault, Venture, Verve, Verve Forecase, Victor, Victrola, Vista, Volt, Vox, Weis, Whiz, Yew, Zodiac).  
 TAPE: (Ampex, GRT, Atl. Stax, Elek, DGG, Vanguard, Polydor, RCA)

## NEW JERSEY

**CAMDEN—(609)**  
 •**Decca Dist. Corp.**  
**1722 Federal Street**  
**Robert Specca 966-7111**  
 (Berlitz, Bravo, Brunswick, Colonia, Decca, Kapp, MTA, Standard, Vocalion).  
 TAPE: (Same as above)

•**Liberty/U.A. Record Dist. Corp.**  
**7025 Colonial Highway**  
**Pennsauken**  
**Dave Levey 662-3101**  
 (Liberty, Imperial, Dolton, Blue Note, World Pacific, Pacific Jazz, Sunset, United Artists, Veep, Solid, State).

## NEWARK—(201)

•**All-State New Jersey, Inc.**  
**321 Sherman Avenue**  
**Sherman Koenig, Irwin R. Fink 242-6500**  
 (Alstan, Atco, Best, Brooklyn, Caria, City, Coliseum, Commonwealth United, Deramic, Dunwich, Dynamo, Enterprise, Felsted, Four Corners, G.W.P., Garpax, Jab, Kapp, Karen, KoKo, London, M.O.O. ment, Musicor, Parrot, Phase 4, P. Pompelli, Press, Richmond, Rising Sun, S.P.Q.R., Seville, Sire, Sound Stage, Stereo Treasury, Threshold, Volt, Vortex).  
 TAPE: (Ampex, Atco, Atlantic, Capitol, Caytronics, Columbia, Certron-Vivid, Decca, Dot, Fiesta, G.R.T., I.T.C.C., Kapp, Liberty, Mercury, North American, Sure, Pickwick, Stax-Volt, United Artists)

•**Apex-Martin Record Sales**  
**467 Mundet Place**  
**(Hillside)**  
**Joe Martin, Jerry Cohen 923-7474**  
 (A&M, Amazon, Army, Amos, Aph, Aquarius, Bang, Bell, Blue Rock, Callange, Colossus, Congress, Cotillion, CTI, Cyclone, Deluxe, Dionn, DJM, Dot, Shot, Duo, Elf, Embryo, Fantasy, Fiesta, Galazy, Generation, Greco-phone, Honor Brigade, Hilary, Intrepid, Jamie, LHI, Limelight, Little David, Lolo, La Mala, Maxwell, Mercury, Milestone, Moira, Nashville, Ode'70, Oracle, Pag, Paramount, Peachtree, People, Phillip, La-Of-Soul, Philly Groove, Plantation, Pride, Revue, Smash, Shama, Shamley, Shout, Silver Fox, Starday, Steel, SSS, Syntonic Research, Talent Ass, Tonsil, Top and Bottom, Torries, Thun, Uni, Vault, Virtue, Volume, Wayside, Whale, Whiz, Windfall, Zodiac).

**Essex Record Distributors, Inc.**  
**10 Fenwick Street**  
**Joe Cohen, Irving Cohen 243-7700**  
 (All Platinum, Anvil, Blue Thumb, B.T. Backbeat, Bashie, Bamboo, Blue Fox, Checker, Chess, Creed, Crescent, Dak, Lite, Dial, Diamond, Diplomat, Doots, Excello, GRT, Golden, Gospel, Head, Jewel, Josie, Jubilee, Kent, Kiondike, Laurie, Mace, Money, Nashboro, Neptune, nal Sound, Paula, Peacock, Peter Pan, Ron, San Francisco, Scepter, Skye, Son, Speciality, Stang, Stax, Stella, Stone, Stop, Sureshot, Unity, U.S.A., Wand, bound, Whit, Yew).  
 TAPE: (ABC, A&M, Atlantic, Atco, Bang, Bluesway, Buddah, Blue Thumb, Cadet, Checker, Capitol, Columbia, Command, lion, Curtom, Colonial, Dynovoice, Decca, Diamond, Dunhill, Elektra, Epic, lo, Fantasy, Fontana, 20th Fox, Gambia wax, Gordy, Gross, GRT, Hickory, Ho pulse, International, Itco, Janus, Jad, Josie, Jubilee, Kama Sutra, Kapp, King, Laurie, Liberty, London, Limelight, Mains, Mercury, Moonglow, Modern, Mont, Motown, Musicor, Metromedia, Nashboro, Voice, Original Sound, Okeh, Palisade, Pavilion, Peacock, Philips, Philly Grove, tion, Paula, Polydor, Pompeii, Prestige, Project, Paramount, Ranwood, Raw, RC, prise, Request, Roulette, Savoy, Scepter, ate, Soul, Skye, Smash, Sound Stage, S ty, Shelby Singleton, Sphere Sound, Steed, Stop, Stella, Sundi, Sun, Tamla, T Tetragramton, Nal, Tower, UNI, Unity, guard, Vault, Verve, Viva, Volt, VJ, Vortex, White Whale, Windfall, Warner Bros.)

**Krich New Jersey Inc.**  
**428 Elizabeth Avenue**  
**Norris Shurman 248-7400**  
 (RCA, Camden, Victrola, Colgems, Kir, Poppy).  
 TAPE: (Same as above)

**Distributing Corp.**  
**46 Green Street**  
**Joe Fechner 623-5984**  
 (Amos, Conversaphone, Disneyland, Evo, LHI, Living Language, Project 3, Re, Straight, June, Warner Bros.)  
 TAPE: (Disneyland, Living Language, Re, June, Warner Bros.)

(Con't on next p

# HEAVIEST

IN  
NORTHERN CALIFORNIA

The companies we represent in the big northern California market get the heaviest, most aggressive promotion, sales and merchandising know how. Call us if that's the kind of deal you want for your label.

Vice President and General Manager: Jack Solinger  
 Promotion: Paul Pieretti, Rich Swig, Bud Hayden

## H.R. BASFORD COMPANY

800 MARIPOSA STREET, SAN FRANCISCO, CALIFORNIA 94107  
 Direct Line 415 / 626-5494

## Philadelphia's Largest RACK MERCHANDISER

**Is Also The Most Effective  
DISTRIBUTOR  
In This Important Market**

For Results  
Look To:



## RAYMOND ROSEN

Music Products  
 Parkside Ave. at 51st St.  
 Philadelphia, Pa. 19131

Philadelphia's Only "Full-Service" Distributor

Contact: AL ROSENTHAL  
 (215) 878-2200

# EVERYBODY KNOWS!

"1970's Most Promising Female Vocalist."

(Cash Box Disc Jockey Poll)



## MELANIE



Exclusively on Buddah  Records

ALSO AVAILABLE ON AMPEX 8-TRACK CARTRIDGE AND CASSETTE STEREO TAPES.

CONGRATULATIONS ON YOUR 28th

# RECORD MERCHANDISING COMPANY, INC.

2580 West Pico Blvd.  
Los Angeles, Calif. 90006  
(213) 385-9161

Most Powerful Promotion and Sales Staff on the Coast

## CHAPMAN DISTRIBUTING CO. LA's Finest Distributor

Manufacturers' Inquiries Most Welcome.  
Your Product Deserves Personal Attention.  
Complete Lines of Religious, Gospel and Sacred.

Contact:

### CHAPMAN DISTRIBUTING CO.

2645 W. Pico Blvd. Los Angeles, Calif. 90006  
Phone: (213) 385-3636

Eastern Pennsylvania/Southern New Jersey/ Delaware



**A & L's** many skillful hands point  
to a Complete Distribution Facility

Complete Tape Rack Service  
Complete Consumer Electronics Line  
For Auto & Home  
T.V. Color & Black & White  
CALL:

**Al Melnick**

Philadelphia, Pa. (215) Poplar 5-4300  
S.E. Cor. 30th & Thompson St.

# A & L

DISTRIBUTORS, INC.

# Record Distributors

### •NARM MEMBERS

•Liberty/U.A. Dist. Corp.  
1835 Burnet Avenue  
(Union)  
Jack Bridges 964-1560  
(Liberty, U.A., Blue Note, Imperial, Soul City,  
World Pacific, World Pacific Jazz, Sunset,  
Veep, Minit, Unart)

•Wendy Distributors, Inc.  
37 William Street  
Jerry Winston 623-5845  
(Abnak, Avco, Embassy, Buddah, Canyon,  
Crescendo, Curtom, Dooto, Elektra, Era, Feder-  
al, Flying Dutchman, GNP, Gamble, Glad  
Hamp, Heritage, Hickory, Harbour, Hot Wax,  
Kama Sutra, King, MGM, Mainstream, Metro-  
media, Nonesuch, Prestige, Pavilion, Polydor,  
Ranwood, Royal American, Savoy, Spring,  
Steady, Sue, Super K, Team, T-Neck, TRX,  
Thomas, Vanguard, Verve)  
TAPE: (Ampex, GRT, ITCC)

### NEW YORK

#### ALBANY—(518)

RTA Distributors Inc.  
991 Broadway  
Joe Paone 463-3251  
(RCA Victor, RCA Camden)

•Transcontinental Distr. Corp.  
100 Watervliet Ave.  
Roy Roland 438-3571  
(Cadet, Checker, Chess, Elektra, Gordy, Mo-  
town, Nonesuch, RCA, Roulette, Scepter, Soul,  
Tamla, Wand)  
TAPE: (Elektra, Gordy, Motown, Roulette,  
Scepter, Soul, Tamla, Wand)

#### BUFFALO—(716)

Best & Gold Record Distributors  
1790 Main Street  
David Colson—882-0427  
(ABC, Atlantic, Atco, A&M, Audio Fidelity, Ab-  
nak, Arc Sound Ltd., Aphrodisiac, Artic, Atilo,  
Autumn, Ardent, Airtown, Ashley, Audio Rec-  
ords, All Platinum Ardent, Airtown, Ashley,  
Audio Records, All Platinum Artco, Amy,  
American, Action Aquarius, Amos, Adell Int.,  
Brooklyn, B.T. Puppy, Botanic, Back Beat, Blue  
River, Bellina, Big Ben, Buena Vista, Bang,  
Burdett, Baytown, Boom, Big Deal, Buena Vis-  
ta, Bang, Burdett, Baytown, Boom, Big Deal,  
Boone, Blue Onion, Bullet, Buluu, Brotherhood  
Bazaar, Blue Thumb, Blue Angel, Command,  
Current, Checkmate, Challenge, Crusader,  
Calla, Carnival, Cotillion, Curtom, Crest, Circa,  
CCM Prod., County Fair, Cobblestone, Crescent,  
CBM Prod., Congress, Crimson, Chance, Celeb-  
rity, Circle, Chartmaker, Cotique, Corby, Dou-  
glas, Dunhill, Diamond, Dakar, Dimension, Dis-  
neyland, Dynamo, Dooto, Derby City, Deutscher-  
grammophon, Duke, Doubleshot, Dover, Drew,  
Divenus, Dearborn, Delta, Dunwich, Enterprise,  
Era, Evolution, Excello, Eurotone, Eldo, Estill,  
Elbejay, Expo, Earl, Eric, ESP, Event, Four Cor-  
ners, Fard, Foy, Fiesta, Federal, Fury, Focus,  
Fortune, Guyden, Groovy, Gross, Gospel, Gam-  
ble, Guilford, GRC, GRT, GWP, Grecophon,  
Gold Wax, Harbour, Hollywood, Hot Line, High  
Country, Hob, Hot Wax, International Artist,  
Impulse, Jerden, Jamie, Jay Jay, Jewel, Jubi-  
lee, Jossie, Jad, Karp, Kent, Karen, Ko Ko, King,  
Living Language, Little Darling, Laurie, Lemon  
Line, Lost Night, Like, Modern, Mira, Mothers,  
Modo, Mala, Mainstream, Monument, Musicor,  
Money, MTA, Mirwood, Metromedia, Nashville,  
New Voice, Paula, Pure Soul, Peacock, Pavil-  
ion, Philly Groove, Plantation, Phil La Soul,  
Original Sound, Oren, Probe, Pace, Pepper,  
Pelnor, Post, Poppy, Pompeii, Queen City,  
Riverside, Ranwood, Rojac, Rod, RPR, Rou-  
lette, Rontom, Royal American, Sew City,  
Shout, Sphere Sound, Strob, Sure Shot, Song-  
bird, Storday, Savoy, Super K, Stang, Scepter,  
Suv, Shell, Stax, Stereodoties, Skye, SSS,  
Spar, Share, Sahara, Sue, Stereo Dimension,  
Soma, S&P, Squire, Springboard, Sundown,  
Steel City, Straight, Tower, Triangle, Take 6,  
T Neck, Twilight, Thunderbird, Turntable,  
Tarp, Tangerine, UNI, USA, Venture, Volt, Vent,  
Vernell, Vault, White Whale, Weiss, Westbound,  
Wand, Windy C, Wayout)  
TAPE: (8 Track & Cassette-Ampex, Atco, At-  
lantic, Capitol, Columbia, Decca, Epic, GRT,  
ITCC, Jubilee, Kapp, Liverty, Mercury, Motown,  
NAL, RCA, Scepter)

•Decca Distr. Corp.  
Shero Road  
(Hamburg)  
Maury Bloom 852-8318  
(Decca, Coral, Vocalion, Berlitz, Caedmon, Lon-  
don, MTA, Standard & Colonial, Viva-Bravo)

#### NEW YORK CITY—(212)

•ABC Record and Tape Sales  
46-50 54 Avenue  
(Maspeth)  
Walter Lam 786-6255  
(ABC, Award, Artist, Bluesway, Buluu, Com-  
mand, Dunhill, Grand Award, Impulse, Movie-  
tone, Music Guild, Probe, Riverside, Tangerine,  
20th Century Fox, Westminster)

•Alpha Distributing Corp.  
20 West End Ave.  
Harry Apostoleris, Murray Viscose 586-6200  
(A&M, Alector, Ansonia, Ampex, Avoca, Bell,  
Amy, Elf, Flashback, Gold Wax, Mala, Philly-  
Groove, Page One, Windfall, Talent Assoc., Blue  
Horizon, Disneyland, Buena Vista, D.Q., Story  
Teller, Everest, Archive of Folk, Archive of  
Gospel, Archive of Piano, Baroque, Cetra, Con-  
cert Disc, Counterpoint, Esoteric, Period,  
Piourette, Tradition, Showcase, GNP-Crescendo,  
Accent, Gordy, Hickory, TRX, HiFi, Internation-  
al Artists, Jamie, Artic, Dionn, Phil La of Soul,  
Jewel, Ronn, Paula, King Deluxe, Loma, Metro-  
media, Monument, Sound Stage, Motown,  
Mona-Lee, Monmouth-Evergreen, Project 3,  
Polydor, Reprise, Request, Rare Earth, Soul,  
Starday, Nashville, Hollywood, Stella, Tamla,  
Vanguard, Everyman, Bach Guild, Cardinal,  
Vip, Warner Bros.)  
TAPE: (A&M, ABC, Abnak, Alegre, Accent,  
Amy, Allector, Artic, Bang, Bell, Bluesway,  
Chess, Checker, Cadet, Command, Probe,  
Dunhill, Diamond, Gamble, Goldwax, Gordy,  
GNP, Hickory, HiFi, Impulse, Jamie, Jerdan,  
Kapp, King, Mala, Monument, Motown, Musicor,  
N. Voice, Paula, P. Groove, Phil Soul, Project 3,  
Plantation, Polydor, Reprise, Roulet, Rising Son,  
Ranwood, Request, Soul, Scepter, S. Stage, S.  
Sound, Starday, Specialty, Stella, Tamla, Te-  
tra, TRX, Tower, Uni, Tico, Warner Bros., Vault,  
White Whale, Wand)

•Beta Record Dist. Co. Inc.  
599-10th Avenue  
John Halonka 244-3744  
(Abnak, All Platinum, Dictation Disc, Bruns-  
wick, Back Beat, Certron, Duke, Bang, CTI,  
Gamble, Ethnic, Highland, Money, Musicor,  
Hob, Peacock, Scepter, SSSI, Minaret Ford,  
Plantation, Uni, Revue, Song Bird, Republic,  
Ford, Laurie, Banner, Oracle)

•Brun International Recotape Corp.  
460 West 34th Street  
Jack Silverman 564-3062  
(Archive, Caedmon, Candide, Colgems, DGG,  
Disneyland, Kirschner, Heliador, Poppy, RCA,  
RCA Camden, RCA Victor, Turnabout, Vox)  
TAPE: (Ampex, Archive, Buena Vista, Caed-  
mon, Colgems, Crescendo, DGG, Diamond,  
Gamble, Golden Tape Library, Heliador, Kir-  
schner, Poppy, RCA, RCA Camden, Vox, White  
Whale)

•Capitol Records Dist. Corp.  
1290 Avenue of the Americas  
Howard Aronson 765-0890  
(Capitol, Angel, Seraphim, Apple, Invictus,  
Fame, Trump)

•Columbia Records Sales  
45-20 83rd Street  
(Elmhurst)  
Paul Smith 898-1900  
(Barnaby, Blue Horizon, Columbia, Date, Epic,  
Harmony, Odyssey, Okeh, Kinetic, Fillmore,  
Gazette)  
TAPE: (Columbia, Date, Epic, Ode)

•Dome Distributing Corp.  
43-42 10th Street  
(Long Island City)  
Bernie Block, Stan Drayson 786-9637  
(Allegre, Anvil, Alshire, Amaret, Amos, Bam-  
boo, Blue Thumb, Bluestime, Buckboard, Boi-  
graph, Beverly Hills, Calla, Canyon, Chess,  
Checker, Cadet, Concept, Cotique, Crewe, Cur-  
tom, Delite, Disneyland, Design, Demeter,  
D.J.K., E.D.C., Elephant 5, Dynamo, Earth, DBI,  
Fania, Fantasy, Firebird, Fleetwood, Flying Dut-  
chman, Forward, Gold Award, Head, GRT, His-  
torical, Hobbit, Hot Wax, Janus, Leisure Sight  
Sound, Lolo, Life, Mainstream, Maxwell, Orig-  
inal Sound, Map City, Neptune, Mardi Gras,  
National General, Ono Crest, BT Puppy, P.I.P.,  
Pickwick International, Pzazz, Red Lion, Re-  
car, Roulette, Toddlin Town, People, Percep-  
tion, Silver Fox, Springboard, Sue, Sun, Swin-  
ger, SSS Int'l, Syntonic Research, Tico, Time,  
Together, T Neck, Tiffany, Top N Bottom, Up  
Front, Thomas, Wand, Westbound, Music Disc,  
Instant Lang., White Whale, Phono Record  
Mgt.)  
TAPE: (GRT, Chess, Janus, Fantasy, Main-  
stream, DBI, Blue Thumb, Shelter, Audio Mas-  
ters, Springboard, Up Front, Sun, SSS Int'l,  
Ethnic, Roulette, Disneyland, Pickwick, Crewe,  
Original Sound, Blank Cassettes and 8 Track,  
Head Cleaners)

•Decca Distributing Corp.  
34-24 56th Street  
(Woodside)  
Charles Lindroth 478-6700  
(Brunswick, Coral, Decca, Vocalion, Berlitz,  
Copley, Colonial, Bravo, Viva)  
TAPE: (Brunswick, Coral, Decca)

•Empire State Record Sales Corp.  
10-29 46th Rd.  
(Long Island City)  
Mel Albert, Charles Morrison 361-2700  
(Abel, Aphrodisiac, Ariel, Audio Fidelity, Avant  
Garde, Beacon, Bluesville, Brotherhood, B.T.  
Puppy, Buttercup, Century City, Chart, Con-  
gress, Contessa, Contemporary, Cotillion, Crest-  
view, Crown, Current, Custom, Davis, Dakar,  
(Con't. on next page)



# THE METROMEDIANS

We are extremely proud of our family of artists.  
If you're not familiar with all of them, you will be by the end of 1970.

PETER ALLEN\*  
FRANKIE AVALON  
BLIZZARD  
JOE BROOKS  
THE CATES GANG  
MICHAEL CHAIN\*  
ELEPHANT'S MEMORY  
JERRY FOSTER  
GARY & THE NEW TRAVELLERS  
THE GODFATHERS  
MERY GRIFFIN  
GYPSY\*  
DURWOOD HADDOCK  
CLAY HART  
KAYE HART  
ALEX HARVEY  
RAY HILDEBRAND  
HINES, HINES & DAD  
TAMIKO JONES\*  
JAMIE KAYE  
EDNA LEE  
THE MINDSTICKERS\*  
JIMMY PETERS  
BOBBY SHERMAN  
RICHARD SPENCER & THE WINSTONS  
TOMBSTONE BLUES BAND  
CHILL WILLS

EXCLUSIVELY ON METROMEDIA RECORDS



HARTFORD'S OLDEST INDEPENDENT RECORD DISTRIBUTOR  
SERVING

Conn.—Western Mass.—Upstate N.Y.—Vermont

TRY US and SEE  
**WHY WE ARE NO. 1**

**PROMOTION • SALES • SERVICE**

**SEABOARD DISTRIBUTORS**

A DIVISION OF ROSKIN DISTRIBUTORS, INC.

275 PARK AVE. Phone (203) 289-9361 East Hartford, Conn.

Marv Ginsburg—Sales Manager / Bill Greenberg—Promotion

**WE CAN MAKE IT HAPPEN !**

ALL NORELCO & PANASONIC  
HOME ENTERTAINMENT  
EQUIPMENT AND A COM-  
PLETE LINE OF ACCESSORIES  
INCLUDING: LE-BO, FIOELI-  
TONE, AMFILE, LUVAN, 3 M  
SCOTCH RECORDING TAPE



A&M—BAMBOO—  
CENTRON—CHISA—  
CANYON—  
DISNEYLAND—GORDY—  
HOB—JAMIE/GUYDEN  
LISTEN & LEARN—MMO  
—MONUMENT—ODE 7  
—RARE EARTH  
SCEPTER—SKYE—  
SOUNO STAGE 7  
TAMLA—TODOLIN  
TOWN—VIP—WANO  
—YOGA  
(Records & Books)

**MERIT MUSIC DISTRIBUTORS, INC.**

15771 Wyoming Avenue

Detroit, Michigan 48238

(313) UN 3-9119

**MIAMI  
CAMPUS**

**RECORD DISTRIBUTING CORP.**  
JOE STANZIONE, GENERAL MANAGER

**MIAMI  
CAMPUS**

**RECORD DISTRIBUTION CORP.**  
BOB LA VALLE, SALES MANAGER

**MIAMI  
CAMPUS**

**RECORD DISTRIBUTING CORP.**  
7250 N. W. 36TH AVENUE  
MIAMI, FLORIDA 33147 (305) 691-3140

AN AFFILIATE OF:  
**UNIVERSAL DISTRIBUTORS, PHILADELPHIA, P.A.**

# Record Distributors

•NARM MEMBERS

**EMPIRE STATE RECORD  
SALES CORP. (Con't.)**

Diplomat, Disneyland, Dorado, Double Shot, Douglas, Embryo, Era, ESP, Expo, Fantasia, Faxx, Folklore, Forever, Glad Hamp, Golden, Golden Crest, Good Time Jazz, Grand, Gospel Train, Gross, Guest Star, Happy House, Happy Tiger, Hilary, Humorsonic, Immediate, Irish International, Jad, Jamai, Josie, Jubilee, Laff, Library Edition, Little David, Mary Lou, M.F., Milestone, Mine, Mio, Mira, Mother Goose, Mountain Dew, Music Minus One, Onacrest, Orfeon, Pace, Pentagram, Peter Pan, Post, Power, Prestige, Proscenium, R.A., Radient, Radnor, Raw, Rejoice, Real, Riot, Rocking Horse, Rojak, Roper, Soul Time, Soulville, Stop, Straker, Steady, Stylist, Surry, Swampfire, Takoma, Thrush, Thunderbird, Tiger Tall, Tifton, Truesound, Tucker, Turntable, United, Vibrant, Vista, Whiz, Winley, Wirl, Yew, Yazoo, York)  
TAPE: (Altone, Ambassador, Carnaby, Carnival, Cotillion, Disneyland, Double Shot, Embryo, Gamble, Gross, Hob, Humorsonic, Josie, Jubilee, Kapp, Laff, Majestic, M.F., Modern, Palisade, Prestige, R.A., Radient, Raw, Riot, Roper, Savoy, Scepter, Steady, Telepro, Tifton, Wand, Whiz)

•Malverne Dist.  
35-35 35th Street  
**Al Hirsch, Joe Grippo 392-5700**

(A-Bet, Alston, Atco, Atlantic, Avco-Embassy, Blue Rock, Capricorn, Carla, Commonwealth United, Creed, Crescent, Dade, Dial, Edmar, Enterprise, Evolution, Exello, Flaming Arrow, Focus, Fontana, Front Page, Limelight, Mercury, Nasco, Nashboro, Phillips, Pulsar, Respect, SGC, San Francisco, Savoy, Smash, Specialty, Stax, Stoneflower, Vault, Volt, Vortex, Wayside, Weis, World Wide)  
TAPE: (Atco, Atlantic, Enterprise, Fontana, Limelight, A, Mercury, Phillips, Respect, San Francisco, Smash, Stax, Volt, Vortex)

•Met Richmond Latin Record Dist.

1637 Utica Ave.  
(Brooklyn)  
**David Last 253-4600**

(Seeco, Met Rico, U A Latino, Alma, Norca, BBM, New Tone, Progresso, Tres Banderas, Columбина, Rines, Rumba, Prospect, Explorer, Colonial, Campeon, Fenix, Sono Mex, Metropolitan, Mona, Amex, Odessa, ASA, Reli, Economy, Kasin, Cuica, Encanto, Tropical, Ponce, Filtr, Somar, BRC, Bronjo, Concert Tapes)

Olympia Distributors Corp.

239 West 18th Street  
**Ervin Litkel 989-7200**

(Disneyland, Vista, Pickwick, Decca Phono, Vocalion, Harmony, Ambassador, Diplomat, Design)

Polka Towne Music

23 Marian Lane  
(Jericho)  
**Teresa Zapolska (516) 822-3198**

(Albo, Alshire, Ampol, Bel-Aire, Chicago, Cindy, Cuca, Danceland, Don-Joe, Dyno, Eastwind International, Eurotone, Fantastik, Glo, Gold, Goodwill, Halo, Holts, IRC, "J", JB, Jay Jay, Jody, Lemans, Melodia, MGM, Micro, Monitor, Muza, Oxboro, Pleasant Peasant, Polka, Polkatone, Pronit, Rave, Recar, Request, Rex, Ridge, Rim, S&S, Select, Silverbell, Sound, Starr, Stella, Stella, Studio 5, Tifton, Tip, Tric, Usana, Veriton, Vicrom, Vista)  
TAPE: (8 Track, Bel Aire, Delta International, Don-Joe, Dyno, Eurotone, Goodwill, Halo, MGM, Monitor, Request, Rex, Rim, Roulette, Stella)  
CASSETTES: (Eurotone, Monitor, Stella)

Stanley-Lewis Record Distributing Co., Inc.

23-80 48th Street  
(Astoria)  
**Harry Lew 726-4343**

(Arhoolie, Artia, Audio Arts, Avakian Cage, Bar-enreiter, Barclay (Imp), Bartok, Biograph, BAM, Broadside, CMS, CRI, Caedmon (10"), Caedmon, Caedmon Portfolio, Cambridge, Connoisseur Soc., Conversaphone, Conversaphone (2 rec), Conv. (3 or more rec) Delmark Blues, Delmark Jazz, Desto, Dover (Classic), Dover (Bird Songs), Dover (SW), Dover (List & Learn), Dover (Poetry), Dyer Bennet, EMS, Enrichment, Eterna, Exp. Anon, Festival (Imp), Ficker, Folk Legacy, Folkways, Folkways (Ethnic), Folkways Popular, Folkways Catalogue, Greg. Inst., Haydn Soc., Historical, Lexington, LIRS, Louisville, Lyricord, Monitor (cl), Monitor (inter), Melodean, Motivation, Musica Sacra, Music Minus One, Ocora, Orion, Parliament, Phillips (Imp), Proscenium, Qualitone, Riverboat, Serenus, Spivy, Spoken Arts, Stinkson, Takoma, Turnabout, Urania, Veritas, Vogue)  
TAPE: (Artia, Barclay, Caedmon, Conversaphone, DGG and Archive, Fontana, Monitor, Phillips, Spoken Arts, Vox, Audio Fidelity)

Worldtone Music, Inc.

56-40 187 St.,  
(Flushing)  
**Kenneth Spear, Nomi Spear 357-3490**

(Balkanton, Chant du Monde, Eterna, Hispavox, Jugoton, Radio Television Beograd, Saga Records, Vega Records)  
TAPE: (Hispavox, Jugoton, Vega)

SYRACUSE—(315)

Morris Distributing Co., Inc.  
1153 W. Fayette Street  
Oscar Dachs 475-6531  
(RCA, Vox)  
TAPE: (Ampex, GRT)

**NORTH CAROLINA**

CHARLOTTE—(704)

Bertes Sales Corp.

2214 W. Morehead Street  
**Phil Goldberg, Mickey Beheler 375-2517**  
(A-Bet, Ashley, Banyon Tree, Blue Rock, Blue Thumb, Boone, B.T. Puppy, Cadet, Chartmaker, Checker, Chess, Cotillion, Creed, Crescent, Dakar, Deeso, Deluxe, Epic, ESP-Disk, Evolution, Exello, Gamble, Gordy, Gross, Happy Time, Heartwarming, Hip, Josie, Jubilee, Mainstream, Metromedia, Minaret, Motown, M.T.A., Nashboro, Nugget, Okeh, Plantation, Rojac, Silver Fox, Soul, S.S.S. International, Starday, Tamla, Upfront, Verve)  
TAPE: (Columbia, Epic, Gordy, G.R.T., Gross, Heartwarming, Liberty, Modern, Motown, N.A.L., RCA, Soul, Tamia)

•Bib Distributing Co.

126 W. Morehead  
**Joe Voynow 372-2032**

(All Platinum, Buddha, Bamboo, Bang, Burton, Crewe, Calla, Chart, Colossus, Commonwealth United, Double Shot, Enterprise, Hob, Fantasy, Fontana, Generation, Heritage, Galaxy, Hot Wax, Kent, King, Janus, Mercury, People, Phillips, Original Sounds, Roulette, Decca, Brunswick, Coral, Stax, Scepter, Rojac, Smash, Sue, Thomas, T-Neck, Volt, Wand, White Whale, Zodiac, Wayside, Whiz, Westbound)  
TAPE: (Ampex, Bamboo, Brunswick, Coral, Decca, Dooto, Enterprise, General Recorded Tapes, Gross, Jubilee, King, Laff, Mercury, Orbit, Original Sound, Phillips, RCA, Raw, Scepter, Smash, Stax, Volt, Wand)

•Capitol Records Dist. Corp.

416 East Blvd.  
**Larry Hathaway**  
(Capitol, Apple, Angel, Invictus, Fame, Trump, Seraphim)

F & F-Arnold Distributing Co.

2704 Freedom Drive, PO Box 1126  
**John Towles 399-9741**

(A & M, ABC, Abnak, American Music, Artic, Atco, Atlantic, Backbeat, Band Box, Bang, Barry, Bluesway, Bright Star, Bluesway, Brotherhood, Canaan, Carla, Clarion, Challenge, Command, Custom, Dial, Diamond, Diamond Jim, Dion, Disneyland, Dolly, Dooto, Duke, Dunhill, Dunwich, Dynamo, Elektra, Enterprise, Equinox, Fame, Fantasy, Focus, Four Brothers, Galaxy, Gamma, Golden, Goudy, Impulse, Indigo, Jab, Jamie, Jerden, Jetstar, Jumbo, Karen, Kenwood, LHI, Laurie, Legrand, Like, Little Darlin, Loma, Mojo, Montel, Moonglow, Muscor, MSL, Nonesuch, Peacock, Pepper, Phil-A-Soul, Philies, Pompeii, Project 3, Reprise, Revue, Riot, Riverside, Roulette, Roost, Rust, Shout, Smoke, Soft, Songbird, Stax, Sure-Shot, Tangerine, Thomas, 20th Century Fox, UNI, Vanguard, Vault, Vista, Volt, Vortex, Warner Bros.)

•Liberty/U.A. Distributing Corp.

1415 East Boulevard Suite 219  
**J. H. Epting 334-3046**

(Blue Note, Imperial, Liberty, Solid State, Soul City, Sunset/Talespinners, United Artist, World Pacific, World Pacific Jazz)  
TAPE: (Same as above)

Southern Radio Corp.

1625 West Morehead Street  
**Philip Morgan 376-4461**

(RCA Victor)  
TAPE: (Ampex, GRT, Word, Mercury, Phillips, Smash, Heartwarming, Motown, Gordy, Soul, Tamla, Sun, Columbia, Epic, ITCC, Nai, Paramount, Liberty, United Artists, RCA, Tonka, Capitol, Vividsound, Decca, Gross, Jubilee, Raw, Dooto, Warner Bros., Reprise, Certon)

**OHIO**

AKRON—(216)

Twelgrenn Enterprises, Inc.

2775 Yellow Creek Rd.  
**J. Hugh Macey 836-5591**

(Aqua, Balance, Belco, Black Mountain, Blue Star, Bogan, Express, Family Squares, Flip, Folkraft, Folk Dancer, Go, Grenn, HiHat, Hooter, J Bar L, Jewel, Jocko, Kalox, Keeno, Kimbo, Lloyd Shaw, Longhorn, Lore, Lou-Mac, MacGregor, Magic, Mayflower, Mustang, National, Niagara, Old Timer, Prairie, Red Boot, Rockin' A, Roper, Sashay, Scope, Sets In Order, Square L, Square'N Round, Square Tunes, Sunny Hills, Swinging Square, TOP, Wagon Wheel, Western Jubilee, Windsor, AFA, Artists Life, GEM, Century, Dance Along, Danro, Dancetime, Fiesta, Fontana, Grenn, Hanf, Hooter, HMV, Oriole, Pariophone, Phillips, Polydor, PYE, Rainbow, Roper, Russell, Saga, SMC, Starlite, Sydney Thompson, Telemark, Top, Windsor)

(Con't. on next Page)

*Congratulations*

**TOM**

*on winning the  
Cash Box poll as  
"most programmed  
male vocalist - 1970"*



*It's LP's like this  
that have helped earn  
you this award*



# Record Distributors

## •NARM MEMBERS

### CINCINNATI—(513)

**A & I Record Distributing, Inc.**  
1000 Broadway At Court

**Sam Klayman, Jim Yates 241-7644**  
(Abnak, Alston, Amos, Ampex, Atco, Backbeat, Bamboo, Bang, Cadet, Calla, Capricorn, Checker, Chess, Colossus, Diamond, Double Shot, Duke, Firebird, Gamble, Gospel, Gre-Gar, Gross, G.W.P., Hob, Immediate, International Artists, Jad, Janus, Jetstar, Jewel, Josie, Jubilee, K.B.I., Kent, Limelight, Neptune, Paula, Peacock, Peoples, Philips, Polsar, Pompeii, Power, Prestige, Red Foxx, Ronn, Roulette, Savoy, Scepter, Shout, Songbird, Tetragrammaton, Thunderbird, Toddlin' Town, Tribute, Turntable, Twinnight, U.S.A., Vesuvius, Volt, Wand, West Bound, Whiz, World Series)  
TAPE: (Scepter, Prestige, Chess, Checker, Jay Gee)

### •Capitol Records Distributing Corp.

**35 East 7th Street**  
**Tom Ellison 721-5616**  
(Angel, Apple, Capitol, Invictus, Fame, Trump, Seraphim)

### •Columbia Records Sales

**554-55 Carew Tower**  
**Bill Kelly 241-4088**  
(Columbia, Harmony, Odyssey, Epic, Barnaby, Fillmore, Gazette, Kinetic, Okeh)  
TAPE: (Columbia, Epic)

### •Decca Distributing Corp.

**940 Wareham Drive-Daylight Building**  
**Jack D. Brown 721-4210**  
(Decca, Coral, Brunswick, Berlitz, Standard, Colonial, London, Kapp, Coliseum, Delyse, Deram, Hi, Parrot, Press, Sire, Richmond Opera, Treasury Series, M.T.A., Bravo, Viva)  
TAPE: (Same as above)

### •Liberty/UA Distributing Co.

**11750 Chesterdale Road**  
**Art Liberatore, 771-4832**  
(Liberty, UA, Bluenote, World Pacific, Soul City, Sunset, Veep, World Pacific Jazz, Imperial, Unart)

### •Summit Distributors, Inc.

**211 E. 4th Street**  
**Jack White, Seymour Greenspan 241-6361**  
(A-Bet, Acquarius, Ail Platinum, Altair, Amsterdam, Audio Fidelity, Bazooka, Blue Thumb, Blues Time, Canyon, Certron, Congress, Creed, Crescent, CTI, Delmark, Duo, Era, Excello, Flying Dutchman, Golden, Happy Tiger, Little David, Mainstream, Metromedia, Mr. G., Mobile Fidelity, Nasco, Nashboro, Ode'70, Off Spring, Revue, Shelter, Skye, Soul Clock, Stang, Uni, Up Front, Uptite, Vault, White Whale, Yew, Zodiac)

### Supreme Distributing Company

**1000 Broadway At Court**  
**Albert Klayman 421-0747**  
(ABC, Bluesway, Dunhill, Command, Probe, Impulse, 20th Century, Riverside, Original Cast, Westminster, Atlantic, Dial, Cotillion, Dakar, Enterprise, Stax, Bell, Army, Maia, Gold-wax, AGP, Philly Grove, Elf, Boone, Buddha, Curtom, Pavilion, T-Neck, Cobblestone, Chart, Dunhill, Fantasy, Galaxy, GRT, RSVP, Hickory, Jamie/Guyden, Phila O Soul, Jamie, Artic, Sundi, Mercury, Bluerock, Classical, Playcraft, Childcraft, Wing, Smash, Fontana, Intrepid, Monument, Monument, Sound Stage Seven, Musicor, Dynamo, Plantation, SSS International, Sun, Stax, Stereo Dimension, Evolution, Original Sound)  
TAPE: (Atlantic, Atco, ABC, Dunhill, Mercury, Smash, Philips)

### CLEVELAND—(216)

### Brothers Record Dist., Inc.

**3224 Payne Avenue**  
**Donald E. George, Steve M. Evanoff 696-2133**  
(Ali Platinum, Aquarius, Audio Arts, Bilesse, Black Prince, Blue Fox, Bob Joy, Boo Ga Loo, Carnival, Cap City, Creed, Daywood, Deluxe, Don Joe Polkas, Excello, Firebird, Gamble, Giant, Happy Tiger, Holiday, Hollywood, Hometown, Immediate, Kent, Lamp, Look, Magic City Map City, Maxwell, Met, Milestone, Modern, More, Minaret, Nashbord, Parka, Raftis, Radnor, Renegade, Rovac, Salaam, Saru, Share, Silver Fox, Songee, Stang, Steady, Sue, Tayster, Thrush, TNL Prod, Tonsil, Tories, Tri City, Up Tight, Valtone, Volume, Way Out, Westbound, Zodiac)  
TAPE: (Livingston Audio)

### •Capitol Records Dist. Corp.

**7777 Exchange Street**  
**Jim Johnson, Don W. Ittemore 524-8200**  
(Angel, Apple, Capitol, Crazy Horse, Fame, Invictus, Seraphim, Tower, 1,2,3)

### •Columbia Records

**3510 Chester Avenue**  
**Bud Rieland 431-6300**  
(Columbia, Harmony, Date, Barnaby, Epic, Kinetic, Fillmore, Gazette, Odyssey, Okeh)

### •Decca Distributing Corporation

**1721 Superior Avenue**  
**William Glaseman, Bill Green 621-9770**  
(Decca, Coral, Brunswick, ABC, Berlitz, Blue Way, Calla, Command, Dunhill, Elephant, Ka London, Impulse, Probe, Riverside, Tangerine Vocalion)  
TAPE: (Decca, Coral, Brunswick, London, Parrott)

### •Liberty/U.A. Records Inc.

**7777 Exchange Street**  
**(Valley View)**  
**Byron Giles 524-4230**  
(Blue Note, Dolton, Imperial, Liberty, MTA Pacific Jazz, Solid State, Sunset, United Artists, Veep, World Pacific)  
TAPE: (Same as above)

### •Main Line

**1260 E. 38th Street**  
**J.J. Shipley, Joseph Simone 391-1800**  
(A & M, AJP, Abnak, American International, Ampex, Aphrodisiac, Athena, Audio Fidelity, Avco-Empathy, Blue Horizon, Buddha, Callar, Camden, Canyon, Challenge, Chart, Colgems, Colossus, Commonwealth United, Congress, Crewe, Curtom, Deram, Deutsche Grammophon, Direction, Double Shot, Douglass, Dynamo, Elektra, Event, Evolution, Fanta Forward, GNP, Gordy, Gospel, Gross, Heliodor, Heritage, Hi, Hot Wax, Janus, Josie, Jubilee, Kama Sutra, Kirschner, Laff, Laurie, Little David, MGM, Monument, Motown, Musicor, National General, Nonesuch, Ode'70, Original Sound, Page, Parrot, Pavilion, Polydor, Prestige, Project-3, RCA, Rare Earth, Raw, Reprise, Savoy, Sire, Soul, Sound Stage 7, Springfield, Stormy Forest, Super K, T Neck, Tania, Thunderbird, Together, Uni, United Talent, Vip, Vanguard, Verve, Viking, Warner Bros. White Whale, Whiz)  
TAPE: (A&M, Ampex, Aphrodisiac, Blue Horizon, Calenar, Camden, Chisa, Colgems, Deutsche Grammophon, Elektra, Fantasy, Gordy, Gross, Heliodor, ITCC, Josie, Jubilee, Kirschner, Little David, Motown, Musicor, Nonesuch, One '70, Original Sound, N.A.L., Polydor, Prestige, RCA, Rare Earth, RAW, Reprise, Sunset, Tania, Thunderbird, Vanguard, Warner Bros.)

### Midwest Ltd.

**2150 Hamilton**  
**S. Tirk, R. Schafer 696-7666**  
(Beverly Hills, Chalet, Creed Taylor Inc., Cune, Eye, Diamond, Ford, Greyko, International Artists, Ivanhoe, Kerr, M.F., Monmouth Evergreen, Mothers, Notable, Old Town, Oracle, Perception, RSVP, Rama Rama, Rave, Sound, Steady, Syntonic Research, Trash, Trip, White Bang, Shout, Cotillion, Astro, Dakar, Embryo, Moira, Shama, Disneyland, Buena Vista, D.C. Little Gems, Little L.P.s, Storytellers, Fies, Grecophone, Flying Dutchman, Amsterdam, Bluestime, Flying Dutchman, Gateway Groove, Colony, Dyno, Gateway, Gemini, Rim, Tauri, True Gospel, Haddon, Jad, Banyon Tree, J. Turntable, Jewel, Paula, Ronn, Mercury, Bl Rock, Fontana, Intrepid, Limelight, Mercu Peachtree, Philips, Smash, Virtue, Wayside, Wing, World Series, People, Pride, SSS International, Alvin, Amazon, Double Banyon, Plantation, Sun, Wet Soul, Springboard, Buckboar Offspring, Upfront, Superscope, Keyboard Immortals)

### Seaway Distributors

**12415 Euclid Avenue**  
**Robert V. Wilcox 421-8200**  
(A.A., Atlantic, Atco, Bell, Blue Thumb, Che Cadet, Checker, Neptune, Duke, Peacock, Hickory, Jamie-Guyden, Kapp, King, Mainstream, Metromedia, Original Sounds, Polydor, Blue Horizon, Deutsche Grammophon, Arch Production, Heliodor, Spring, Ranwood, Scatter, Skye, Stax, U.S.A., Vault, GRT, MSK, Jew Paula, Paramount-Dot)  
TAPE: (Atlantic, San Francisco, Respect, Warner, Bamboo, Four Corners, Atco, Stax, Volt, Ho Paramount, Vortex, Enterprise, Scepter, Ort Kapp, Polydor, Blue Horizon, Deutsche Grammophon, Archive Productions, Heliodor, Spring)

## OKLAHOMA

### OKLAHOMA CITY (405)

### •B & K Distributing Co., Inc.

**129 N.W. 23rd Street**  
**525-7509**  
(ABC, Abnak, Alston, Anvil, Apt, Atco, Atlantic, Back Beat, Bluesway, Carla, Command, Cotillion, Dakar, Dial, Diamond, Dolton, Duke, Dunhill, Dunwich, Embryo, Enterprise, Excello, Fantasy, Gamble, Grand Award, Hip, Imperial, Impulse, Janus, Jet Star, KoKo, Liberty/UA Inc., Little David, Living Language, Mer Movie, Music Guild, Nashboro, Peacock, Pete, Premier, Probe, Riverside, SGC, Sta Sunset, Tangerine, Twentieth Century Fox, Vault, Volt, Vortex, Westbound, Westminster Young People's)  
TAPE: (Same as above)

### •Decca Dist Corp.

**1733 Northwest 63rd Street**  
**Troy P. Bowen 843-3635**  
(Decca, Coral, Brunswick, Kapp, Elektra, Nonesuch, Dandelion, Berlitz, Colonial, MTA, Viva Bravo)

(Con't. on next page)

## SCHWARTZ BROTHERS, INC.

AREA'S LARGEST RECORD & TAPE DISTRIBUTOR

2146 24th Place, N.E.  
Washington, D. C. 20018  
(202) 529-5700

SERVING: MARYLAND—VIRGINIA  
W. VIRGINIA—DELAWARE and  
DISTRICT OF COLUMBIA

## DISTRICT RECORDS, INC.

AREA'S MOST MODERN RECORD MERCHANDISER

2146 24th Place, N.E.  
Washington, D. C. 20018  
(202) 832-3600

SERVING: MARYLAND—VIRGINIA—  
W. VIRGINIA—DELAWARE—  
WASHINGTON, D. C.—KENTUCKY—  
PENNSYLVANIA—NORTH and  
SOUTH CAROLINA and NEW JERSEY

## 3 GREAT LOCATIONS TO SERVE YOU

With All Records and Tapes

### LET US MERCHANDISE YOUR COMPLETE RECORD AND TAPE DEPARTMENTS

**BALTIMORE**  
2025 Worcester Street  
Baltimore, Maryland 21203

**HARRISBURG WEST**  
500 Terminal Road  
Camp Hill, Penna. 17011  
(Harrisburg)

**WASHINGTON**  
2500 Schuster Drive  
Cheverly, Md. 20781

- We supply fixtures.
- Supply divider cards.
- Categorize merchandise in racks.
- Shrink wrap all merchandise.
- Preprice merchandise with colorful tamper proof tags.
- 24 hour service.
- Offer 100% exchange for credit.
- Weekly personal sales calls.
- Supplementary telephone service.
- Special order service.
- Complete line of players, record & tape accessories.

- Complete selection of cartridge and cassette tapes.
- We run promotions.
- Supply promotional material.
- Computer analysis information.
- Experienced sales & marketing personnel.

**D&H IS CUSTOMER ORIENTED**

**FOR THE BEST SERVICE IN THESE AREAS**

**Call (717) 761-2805 Collect for Service**

Sly & the Family Stone

# HIGHER!



# Record Distributors

## •NARM MEMBERS

**Dulaney, Inc.**  
100 N.W. 44th St.  
Clyde C. Ball JA8-0511  
(RCA, Camden.)  
TAPE: (Ampex Group, Capitol, Columbia)

## PENNSYLVANIA

### HARRISBURG (717)

•**D & H Distributing Company**  
500 Terminal Road  
David Press, Endo Corsetti 761-2805  
(RCA)  
TAPE: (Ampex, Capitol, Columbia, Decca, DooTo, Epic, GRT, Jubilee, Liberty, Mercury, Modern, Motown, Muntz, Original Sound, RCA, Radiant, Starday)  
**PHILADELPHIA (215)**

•**A & L Distributors Inc.**  
S.E. Cor. 30th & Thompson Street  
Albert Melnick, Si Paul P05-4300  
(Academy, Afro, AGP, Amy, Audio Arts, Avoca, Bell, Beverly Hills, Cadet, Conversaphone, Betty White Dance Series, Language Courses, Steno-Speed Courses, DJM, Elektra, Elf, Eurotone, Fantasy, Flashback, Folkways, Galaxy/Fantasy, Glad Hamp, Goldwax, Happy Time, Kent, Laff, Mala, Maxwell, Milestone, Mio, Mobile Fidelity, Modern, Mutt & Jeff, Monitor, Murrill, Music Minus One, Proscenium, New Voice, Nonesuch, Page One, Pickwick/33, Power, Richard Dyer Bennett, Request, Philly Groove, Rojac, Sphere Sound, Show Biz, T.A., Tayster, Tikva, Windfall)  
TAPE: (All labels)

•**Capitol Records Dist. Co.**  
7708 City Line Avenue  
John Sanmartino 877-4167  
(Capitol, Angel, Seraphin, Apple, Invictus, Fame, Trump)

•**Chips Distributing**  
2750 N. Broad Street  
Ernie Santone, Mario Daulerio 226-4600  
(Alfa, Alma, Archive, Avant Garde, Blue Horizon, Blue Rock, Canaan, Carnival, Chalom, Chestnut, Childcraft, DGG, Diamond, Disneyland, Dore, Dyno, Emarcy, Fidelitone, Fleetwood, Fontana, GNP Crescendo, Gamble, Gateway, Heliodor, Limelight, Mercury, Mira, Mirwood, Nugget, Peachtree, Philips, Playcraft, Polydor, Rave, Rim, Sacred, Smash, Spring, Stella, Virtue, Vista, Wayside, Word)  
TAPE: (Blue Horizon, DGG, Disneyland, Fontana, GRT, Heliodor, Limelight, Mercury, Philips, Polydor, Smash)

•**Columbia Records Sales**  
4 Penn Center Plaza-Suite 224  
Edward J. Masterson L08-4445  
(Columbia, Epic, Harmony, Kinetic, Gazette, Fillmore, Odyssey, Barnaby, Okeh)

•**Hitsville of Pennsylvania**  
2750 N. Broad Street  
Ernie Santone 226-4600  
(Gordy, Motown, Tamla, Rare Earth, Soul, VIP)  
TAPE: (Gordy, Motown, Tamla, Soul, VIP)

•**Mamel Dist. Co., Inc.**  
2512 N. Broad Street  
Marshall Verbit 226-1222  
(Ampex, Atlantic, Audio Fidelity, Bang, Caedmon, Calla, Choise, Dooto, ESP, Fiesta, Forward, GRT, Jubilee, Josie, Mo Ko, Laurie, Livingstone Audio, Lost Nite, Mainstream, Pace, Prestige, Riot, Roulette, Savoy-Gospel, Specialty, Starday-Deluxe, Nashville, Stax, Project 3, Tower, Vox-Candide, Turnabout)

•**David Rosen Inc.,**  
851-5 N. Broad Street  
David Rosen, Harry Rosen CE2-2907  
(ABC, AJP, Amaret, Apt, A/S, Athena, Avco, Embassy, Bannor, Bethlehem, Bizarre, Bluesway, Buluu, Cadet, Cader Concept, Checker, Chess, Cotillion, Cross, Dakar, Diety, Dunhill, Dynamo, Embryo, Evolution, GRT, Head, Hickory, Hob, Hobbitt, Impulse, Intrepid, Jamal, Julmar, King, Lionel, Loma, Mace, Magic Carpet, Meka, Moira, Monument, Movietone, Musicor, Neptune, Post, Radnor, Reprise, Riverside, Scepter, Shamma, Soft, Sound Stage 7, Stereo Dimension, Straight, Sure, Tambourine, Tangerine, Tiffany, Tri City, 20th Century Fox, Virtue, Warner Brothers, Young People, Living Language)  
TAPE: (All Lines)  
CASSETTE (GRT Warner Bros., Reprise)

•**Raymond Rosen Music Products, Inc.**  
51st & Parkside Avenue  
Alfred I. Rosenthal TR8-2200  
(Ampex, Chart, Camden, Colgems, Kirschner, RCA, Victrola)

•**Scorpio Music Distributors Inc.**  
6720 Broad Street  
Michael Adler 549-5772  
(Blues Classics, Bluestown, Destiny, Fordham, Gallant Fox, Group Classics, Java, Infinite, Masters, Pantomime, Rendezvous, Rock, Savage, Scorpio, Spiritual Sound, Snowflake, Speedy, Splatter, White Wonder, "Oldies but Goodies")

•**Universal Record Dist.**  
919 N. Broad Street  
Len Rackliff, Jim O'Rourke CE2-3333  
(A & M, Atco, Blue Thumb, Buddah, CTI, CGG, Command, Janus, London, Metromedia, MGM/Verve, Original Sound, Ranwood, SSS International, UNI)

## PITTSBURGH (412)

•**Columbia Record Sales**  
220 Porter Building  
Sixth & Grant  
Solly Solomon 261-2844  
(Columbia, Epic, Date, Harmony, Barna Kinetic, Fillmore, Gazette, Odyssey, Okeh)

•**Decca Distributing Corp.**  
1331 Fifth Avenue  
(Decca, Coral, Colonial, MTA, Viva, Bra London)  
TAPE: (ABC, Roulette, London)

•**Main Line Records**  
84 Van Braam  
Richard Iezzi, Bob Sholes 471-6686  
(A&M, American International, Athena, B Horizon, Canyon, Challenge, Chisa, Cre Deram, Deutsche Grammophon, Dynar Elektra, Evolution, Forward, Gordy, Heliodor, MGM, Motown, Musicor, Nonesuch, Ode Parrot, Polydor, Prestige, Rare Earth, Sire, Sc Spring, Stormy Forest, Tamla, Threshhc Together, VIP, Verve)  
TAPE: (A & M, Blue Horizon, Chisa, Deuts Grammmophon, Elektra, Gordy, Heliodor, Moto Musicor, Nonesuch, Ode '70, Polydor, Presti Rare Earth, Soul, Tamla)

## PUERTO RICO

### SANTURCE

**Distribuidora Nacional De Discos Inc.**  
Cerra 606  
Gilberto Gonzales 727-4964  
(Borinquen, Liberty, Dorado, Sonolux, other labels)  
TAPE: (All Labels)

## TENNESSEE

### KNOXVILLE (615)

•**McClung Appliances**  
5915 Casey Dr.  
Albert W. Smith 584-8611  
(Camden, Chart, Heartwarming, RCA, Victrola)  
TAPE: (Ampex, Camden, Capitol, Columbia, Decca, Epic, GRT, Heartwarming, ITCC, Jubilee, Motown, Northamerican Leisure, Pickwick Int'l, RCA, Skylite, Sun, United Artists)

### MEMPHIS (901)

•**Decca Distributing Corp.**  
3132 Birchfield Dr.  
(Decca, Coral, Brunswick, Elektra, Caedmon Berlitz, Language)

**Hot Line Record Distributors**  
596 Lane Avenue  
J.W. Crudgington 525-0756  
(Amaret, Atco, Atlantic, Audio Gospel, Abna Bang, Colossus, Creed, Commonwealth, Diamond, Discation Disc, Dooto, Earth, Ever Enterprise, Evolution, Fantasy, Gamble, GR Gross, Happy Tiger, Intrepid, Jamie/Guyde Janus, Jubilee, King, La Louisianne, La Nashville, Nashboro, Neptune, Ranwood, Red Fox, Savoy, Specialty, Silver Fox, Stan Stax, RCA, Calendar, Camden, Colgems, Victrola, Sue, Sun, Starday, U.S.A., Upfront, Vo White Whale, Yew)

**Record Sales Corp.**  
3000 Fleetbrook Dr.  
Bill Biggs 332-3650  
(A & M, ABC, Avco Embassy, Buddah, Bel Bluesway, Bluenote, Bamboo, Canyon, Ches Checker, Cadet, Cotillion, Chisa, Curtom, Crescendo, Command, Crewe, CTI, Dakar, Delit Duke, Double Shot, Dot, Dunhill, Crew, Derant Elektra, Giant, GWP, Hi, Hob, Imperial, Impuls Jewel, Jamal, Jad, Kent, Kapp, Liberty, Lauri Living Lang., London, Little David, Monument Minaret, Money, Minit, Modern, Metromedia, Maxwell, Nonesuch, Pavla, Plantation, Parr Peacock, Probe, Reprise, Revue, Roulette, SS Int'l, Sound Stage Seven, Songbird, Sure Shd Scepter, Soul City, Sport, Steady, Tangerint T Neck, Tetragrammaton, Uni, U.A., Vee Wand, Warner Bros., World Pacific, Zodiac)  
TAPE: (All Lines)

### NASHVILLE (615)

**Music City Record Dists., Inc.**  
25 Lincoln Street  
Hutch Carlock 255-7315  
(ABC, Abet, Army, Atco, Atlantic, Audio Boo Avco Embassy, Backbeat, Bang, Bell, Bethle hem, Bluesway, Cadet, Calla, Carnival, Char Checker, Crescent, Chess, Commonwealth United, Dearborn, Delite, Deluxe, Desiree, Dia Duke, Dunhill, Dunwich, Excello, Fantasy, Fedal, Fontana, Four Corners, Fraternity, Fun-I Galaxy, Gamble, Gross, Hob, Hollywood, Hu Puff, Impulse, Jad, Jubilee, Kapp, Kent, King Ko Ko, La Louisianne, Laurie, Limelight, Mai Mayfield, Mercury, Mercury-Philips, Mercur Storytellers, Metromedia, Minaret, Moc, Moc ern, Monument, Movie-Tone, Nashboro, Nashville, Par-T, Peacock, Philly-Groove, Plantation Polydor, B.T. Puppy, Rebel, Red Fox, Renegade Rising Sun, Scepter, Share, Shout, Silver Fo Simco, Smash, Sound Stage 7, Specialty, SS International, Stang, Starday, Stax, Stop, Sur Tangerine, 20th Century, Twinght, Vanguard Volt, Wand, Wies, Wayside)  
TAPE: (All Tape Lines)

## True or False Distribution?

**Mr. Manufacturer:** Are you getting the maximum distribution effort in the area your distributor should be Servicing? Are you getting the attention your line deserves?

**Malverne Distributors** has the means to give you:

1. A large expert and thorough sales force — one who calls regularly on their dealer trade.
2. Excellent Promotion in every area.
3. Not being over burdened with too many lines we can give your line the attention it deserves.
4. Most modern and large warehouse facilities.
5. Financial stability with 24 years of distribution experience.

IN NEW YORK IT'S

**MALVERNE**  
DISTRIBUTORS INC.

35-35 35th Street.  
Long Island City, N. Y. 11108  
(212) 392-5700

**AL HIRSCH, Pres.**

A  
LION'S  
SHARE  
OF THE  
SOUTHERN  
MARKET

Records, Tape Cartridges & Cassettes

BETTER PROMOTION

BIGGER SALES

**GODWIN**

**DISTRIBUTING  
COMPANY**

1270 Tacoma Drive, N.W. Atlanta, Georgia (404) 351-5110

(Con't on next Page)

# Fast Relief for Congested Record Racks.

(For sales stimulus due to minor market miseries.)



A Good Sound remedy.



**T51000 "CRY FOR US ALL"/NEW BROADWAY MUSICAL:** ORIGINAL CAST ALBUM BY MITCH ("MAN OF LA MANCHA") LEIGH. THIS BRILLIANT RECORDING HITS A NEW HIGH FOR SHOW ALBUM PERFORMANCE AND SOUND ENGINEERING.



**PR4003 PEARL BAILEY/APPLAUSE AND OTHER SHOW STOPPERS:** PEARL BELTS THE TITLE SONG FROM "APPLAUSE" AND TWO HITS FROM "MINNIE'S BOYS"—"RICH IS" AND "HE GIVES ME LOVE" PLUS 7 MORE HITS.



**PR5043 SPACED OUT/ENOCH LIGHT AND THE LIGHT BRIGADE:** MOST EXCITING BREAK-THROUGH IN RECORDED SOUND SINCE THE PERCUSSION ERA! ALBUM FEATURES NEW ELECTRONIC INSTRUMENTS: SONGS BY BACH-ARACH, THE BEATLES AND BACH: "LOVER'S CONCERTO," "BOND STREET," "ELEANOR RIGBY," "WALK ON BY" PLUS 7 MORE.

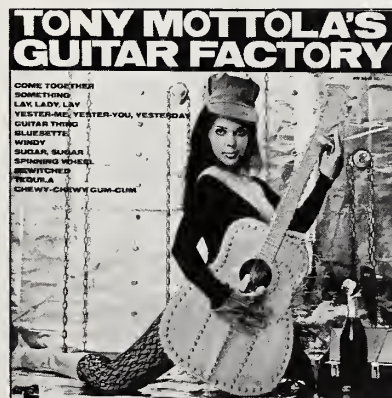

**PR5044 TONY MOTTOLA'S GUITAR FACTORY:** FOREMAN OF THE BOARD OF GUITARS WITH OTHER EXCITING GUITARISTS ON "SOMETHING," "COME TOGETHER," "BLUES-ETTE," "TEQUILA" PLUS 8 MORE.



**T56002 "MINNIE'S BOYS"/NEW BROADWAY MUSICAL:** STUNNING PERFORMANCES BY ORIGINAL CAST WITH HIT SONGS, "RICH IS," "HE GIVES ME LOVE" PLUS OTHER BIG PRODUCTION NUMBERS FROM SHOW. SUPERB STEREO SOUND RECORDING.



**PR5045 FREE DESIGN—STARS/TIME/BUBBLES/LOVE:** EXCITING, BRILLIANT INTERPRETATIONS BY A NATIONALLY ACCLAIMED CONTEMPORARY GROUP: "RAINDROPS KEEP FALLING ON MY HEAD," "BUTTERFLIES ARE FREE," "TOMORROW IS THE FIRST DAY OF THE REST OF MY LIFE," "TIME AND LOVE" AND SEVEN MORE.

# Record Distributors

## •NARM MEMBERS

**Southern Record Distributors, Inc.**  
467 Chestnut  
James Green 254-1991  
(Abnack, Airtown, Amaret, Ariel, A.T.A.C., Audio Fidelity, Avant, Bashie, Blue Thumb, Buena Vista, Canaan, Chart, Chris, Colossus, Congress, Cotillion, Crescendo, Crew, Dakar, D.C.A., D.C. Sound, D.E.K., Desiree, Diamond, Diamond Jim, Disneyland, Dooto, Double Shot, Event, Evolution, Fania, Flying Ditchman, Generation, Gordy, Gospel, Heartwarming, Impulse, Inter Artist, Ivanhoe, Jewel, Kashe, Mainstream, Mothers, Motown, Musicor, Musictown, National Gen., Original Sound, Pace, Pacemaker, Paula, People, Prestige, Probe, Project 3, Ranwood, Revue, Ronn, Roulette, Royal American, Savoy, Sing, Skylite, Soul, Aue, Tab, Tamala, Timmy, Tonsil, Sussex, Symbolic, Uni, Uptight, White, White Whale)  
TAPE: (Motown, Tamala, Gordy, Soul, GRT, Dooto, Heartwarming, Canaan)

## TEXAS

### DALLAS (214)

**ABC Record and Tape Sales Corp.**  
4841 Topline Drive  
637-4580  
(ABC, Dunhill, Command, Bluesway, Impulse, Riverside, Tangerine)

**•B & K Distributing Co., Inc.**  
1411 Round Table Drive  
637-1920

(Amos, Archive, Blue Thumb, Buddah, Buena Vista, Cobblestone, Crewe, Curtom, Deutsche Grammophon, Disneyland, Forward, GWP, GRT, Harbour, Heliodor, Hotwax, International Artists, Kama Sutra, Loma, Lyr, MGM, Maverick, Pavilion, Pete, Polydor, Radnor, Reprise, Royal American, Solid State, Super K, Team, Thomas, T-Neck, Together, United Artist, Vance, Veep, Venture, Verve, Vista, VSP, Warner Bros., Dot, Paramount, Steed)  
TAPE: (All Labels)

**•Big State Record Dist. Corp.**  
1337 Chemical Street  
Bill Emerson 631-1100

(Abnak, Abet, Airtown, AKP, A&M, AGP, Airborne, Ala, Alston, Amaret, Amazon, Amy, Aquarius, Aquarian, Ariel, Arctic, Ashley, Astro, Atco, Athèna, Atlantic, Avenue South, Back Beat Bamboo, Bang, Bashie, Bell, Black Prince, Blue Fox, Blue Note, Bluestime, Capricorn, Carla, Canyon, Chisa, Commonwealth, Congress, Colossus, Cotillion, Cotique, Cyclone.

(Con't on next Column)

## Big State Record Corp. (Con't)

Crescent, Creed, D. Dade, Dakar, Dart, D.C., DJM, Deluxe, Deram, Dial, Diamond, Dionn, Direction, Dooto, Double Shot, Duke, Dynamo, Elf, Era, Event, Evolution, Excello, Fantasy, Flaming Arrow, Flashback, Foggy Love, Folkways, Fountain, Fraternity, Front Page, Gamble, Galaxy, Goldwax, Gordy, Happy Tiger, Heritage, Hi, Hickory, Hip, Hob, Honor Brigade, Imperial, Jad, Jamie, Janus, Jet Star, Jewel, Josie, Jubilee, K-Ark, Karen, Kent, Ko Ko, Laff, Laurie, LHI, Liberty, Lock, London, Look, Mainstream, Mala, Metromedia, Midnight Sun, Minaret, Minit, M.J., M.O.C., Moira, Modern, Money, Monument, Mothers, Motown, Musicor, Nashboro, Ode '70, Pacific Jazz, Page One, Parrot, Par T, Paula, Peacock, Phil La Soul, Philly Groove, Plantation, Pompeii, Press, B.T. Puppy, Pzazz, Rare Earth, Ronn, Roulette, San Francisco, Savoy, Scepter, Scram, S.G.C., Show Biz, Stone Love, Silver Fox, Smith Whit, Songbird, Soul, Soul City, Sound Stage, Soul Clock, Specialty, SSS, Stang, Starday, Startime, Stax, Steeltown, Stone Flaver, Stoneway, Stop, Sue, Sun, T.A. Tamala, Toddlin' Town, Top & Bottom, Track, Trest, Tribe, Trip, Twiight, Uni, Vault, Vanguard, Vesuvius, Vip, Velt, Wand, Weis, Wet, Soul, Westbound, White Whale, Whit, Whiz, Wideworld, Windfall, World Pacific, Zodiac)

**•Capitol Records Distributing Corporation**  
6730 Oakbrook Blvd.  
Tom Tilton 637-1890

(Angel, Apple, Capitol, Fame, Tower)  
TAPE: (Angel, Apple, Capitol, Fame, Tower)

**•Columbia Record Sales**

8808 Empress Row  
Tom Cade ME1-5680  
(Columbia, Epic, Barnaby, Harmony, Fillmore, Gazette, Kinetic, Odyssey, Okeh)

**•Decca Dist. Corp.**

139 Cole Street  
Tom Rodden, Jack Parker 748-5925, 742-3739  
(Berlitz, Bravo, Brunswick, Caedmon, Colonial-Standard, Coral, Decca, Elektra, Kapp, M.T.A., Nonesuch, Viva, Vocalion)

TAPE: (London)

**•Merrec Distributors**

903 Stemmons Tower West  
Jack Bernstein 631-3531  
(Fontana, Intrepid, Lighthouse, Mercury, Peachtree, Philips, Smash, Wayside)  
TAPE: (Fontana, Lighthouse, Mercury, Philips, Smash)

## EL PASO (915)

**M.B. Krupp Distributors, Inc.**  
311 South Santa Fe Street  
M.B. Krupp, Ruben Irizarry 532-4961

(ABC, A & M, Aishire, Amy, Argo, Artic, Back Beat, Bang, Bell, Bluesway, Boone, B.T. Puppy, Buddah, Bunky, Cadet, Calla, Chart, Checker, Chess, Crescendo, Diamond, Double Shot, Duke, Dunhill, Gamble, Hip, Hurricane, Int'l Artists, Jad, Jamie, Jet Star, Jubilee, Laurie, Look, Mala, Original Sound, Paula, Phil-a-of-Soul, Philly Groove, Plantation, Ranwood, Roulette, Shout, Silver Fox, Stax, Stop, SSS Int'l, Sundi, T Neck, Toddlin' Town, 20th Century Fox, Volt, Wand, Whale, Hittier, Whiz, Bego, Bravo, Bronco, Chico, Colonial, Columbia, Cometa, Corna, D.L.V., Del Valle, Disco Grande, Discuba, Eco, Falcon, Frenes, Ideal, Ivan, Keyloc, Musart, Nopal, Norteno, Oro, Peerless, Primovox, Sombbrero, Texas, Tomi, Valmon, El Zarape)

TAPE: (A&M, Arv, Buena Suerte, Del Valle, El Zarape, Falcon, Keyloc, Musart, Capitol, Columbia, Date, Decca, RCA)

**Sunland Supply Co. Inc.**

2227 Texas Avenue  
William M. Shapiro 533-5901  
(London and London Group, King and King Group, Vox, Vanguard, Fiesta, Living Language, Musart, DDG, Peter Pan, Cricket, Ambassador, Crown, Caedman, Folkways, Original Sound, Young Peoples)  
TAPE: (Ampep, Decca, GRT, Liberty, Muntz, Capitol, Playtape)

## HOUSTON (713)

**Art Jones & Co. Inc.**  
4301 Gulf Freeway P.O. Box 27  
W. L. Whitehead 748-6000  
(Colgems, Kirshner, Poppy, RCA)  
TAPE: (Chart, Colgems, Kirshner, Poppy, RCA)

**•Capitol Records Dist. Corp.**

6400 Westpark Drive  
Dennis White  
(Capitol, Apple, Angel, Invictus, Fame, Trun Seraphim)

**•H.W. Daily Inc.**

314 East 11th Street  
Bud and Don Daily 861-6868  
(Abnak, AGP, Aishire, Amaret, Amazon, Aquarian, Artic, Ashley, Astro, Athena, Bay Bell, Bethlehem, Bluestimes, Boone, Ch Colossus, Contemporary, Carzy Cajun, D, Luxe, Deram, Diamond, Double Shot, Dougl Dynamo, Elf, Era, Eric, Event, Fantasy, Fed Flying Dutchman, Fraternity, Gamble, Gala Boldway, G.W.P., Good Time Jazz, He H land, Honor Brigade, Holiday Inn, Hollywo Immediate, Indigo, Ivanhoe, Jamie, Jets Jewel, Jin, Josie, Jubilee, Judell, King, Laur LHI, London, Look, MLV, Mainstream, Ma Maverick, Metromedia, Minaret, M.O.C., M cor, Nashville, Original Sound, Ovide, Pa One, Parrot, Paula, Pazz, Philly Grove, Phil Soul, Plantation, Press, Rampart, Ronn, S Starday, Soul Clock, Specialty, SSS, Sue, S Stoneway, Swally, T.A., Threshold, Top & B tom, Tug Boat, Turntable, Vanguard, Va Venture, Volare, Whiz, Windfall)

**•Liberty/UA Dist. Co.**

2701 Louisiana Street (Suite 203)  
Murray Habbaz 528-2919  
(Blue Note, Imperial, Liberty, Sunset, So State, Minit, Pacific Jazz, Soul City, Unit Artists, Unart, Veep, World Pacific)  
TAPE: (Liberty, United Artists)

**United Record Distributing**

1613 St. Emanuel Street  
J.D. Copley 228-8151  
(Scepter, Hob, Wand, Bamboo, Uni, Mon ment, Sound Stage 7, White Whale, Lit David, Savoy, Jewel, Ronn, Paula, Revue, T dlin Town, Duke, Peacock, Backbeat)  
TAPE: (All tape lines)

## SAN ANTONIO (512)

**Consolidated Record Sales Corporation**

1390 North Colorado Street  
Charles Cole PE2-8831, PE2-5841  
(Amen, ARV, BCM, Bego, Bernal, Bron Buena, Suerte, Capri, Chemiro, Chico, Clow Cobra, Colonial, Columbia, Cometa, Coron DDT, Dela, De La Rosa, Del Valle, Del W Disco, Grande, DLV, El Pato, El Zarape, E Escorpion, Estrella, Falcon, Fama, Garu, Ir pacto, Jester, Key Loc, Lira, Mex Melody, M sart, Norteno, Nuevo, Orteon, Oro, Pan Ar Peerless, RCA, Redondo, Relampago, Rival, R sina, Sombbrero, Sunglow, Tear Drop, Tex TNT, Triangulo, Vallado, Valmon)  
TAPE: (ARV, Bernal, Capri, CBS, Del Valle Disco, Grande, Discuba, El Zarape, Falco Impacto, Key Loc, Mex Melody, Musart, M sidisc, Norteno, Orfeon, RCA, Rico Vox, Su glow, Targo, Tomi)

## SAN BENITO (512)

**Rio Grande Music Company**  
119 S. Sam Houston Blvd. P.O. Box 861  
Paco Betancourt, John F. Phillips 399-1471  
(Alfa, Amexar, ARV, BCM, Bega, Bego, Berna Bravo, Bronco, Buena Suerte, Camden, Capr CBS, Chachalaga, Chemiro, Chico, Cobra, Col nial, Columbia, Cometa, Corona, Dela, De L Rosa, Del Bravo, Del Rio Del Sur, Del Vall Del West, Falcon, DLV, Dominante, Do Re M Eco, El Pato, Elena, Escorpion, Estrella, Fama Flecha, Freddie, Fuentes, Gabe, Gapoco Grande, Guti, Hurricane, Ideal, Impacto, Ji guero, Jox, Ley Loc, Laredo, Lira, Lorenz Magda, Marsol, Mexico, Mex Melody, Musar NCR, Nopal, Norco, Norteno, Nuevo, Orfeor Oro, Paloma, Peerless, Ramal, Rayo, RCA Vic tor, Redondo, Relampago, Rival, RMC, Rosina Ru Tee, Sombbrero, Son Art, S & R, Sunglov Teardrop, Tejas, Tesoro, Texas, Tipico, Tom Triangulo, Valen, Vallado, Valmon, Zarape, Zaz.  
TAPE: (ARV, Bego, Bernal, Buena Suerte, Capr CBS, Chico, Columbia, Del Rio, Del Sur, D Valle, D.L.V., El Pato, Elena, Falcon, Fuente Grande, Ideal, Impacto, Key Loc, Magda, Ma sol, Mex Melody, Musart, Norteno, Orfeor Peerless, RCA Victory, Sombbrero, Sunglov Teardrop, Tomi, Zarape)

## UTAH

**•SALT LAKE CITY (801)**

**ABC Record and Tape Sales Corp.**  
3575 South 700 West  
Ray Peterson 266-3548  
(ABC, Dunhill, Command, Bluesway, Impulse Riverside, Tangerine, MGM, Scepter)

**Cordova's Importers & Distributors**  
543 West 3rd North, P.O. Box 16065  
Carl C. Cordova 355-0642  
(Bego, Bernal, Buena Suerte, Cap-Latino Chico, Coyote, Del Norte, Del Mar, Del Rio Del Sur, Discos, Columbia, Del Valle, Dom nante, D.V.L., Eco, Del Pato, El Zarape, Fama

(Con't. on next page)

# IN THE SOUTH

IT'S

# ALL SOUTH

FOR RECORDS, TAPES AND ALL TYPES TAPE PLAYERS AND ACCESSORIES

ALL SOUTH DISTRIBUTING CO.

1924 Lafayette St., New Orleans, La.

Henry Hildebrand, Jr.

(504) 522-1157

# IN THE SOUTHLAND

# SOUTHLAND RECORDS DISTRIBUTING COMPANY

1073 Huff Road, N. W.  
Atlanta, Georgia 30318 (404) 351-4821  
Gerald Friedman, President  
Bill Binkley, Sales Manager (LP's)  
Miss Gwen Kesler, Sales Manager (45's)  
Larry King, Promotion  
Jack McIntyre, Tapes



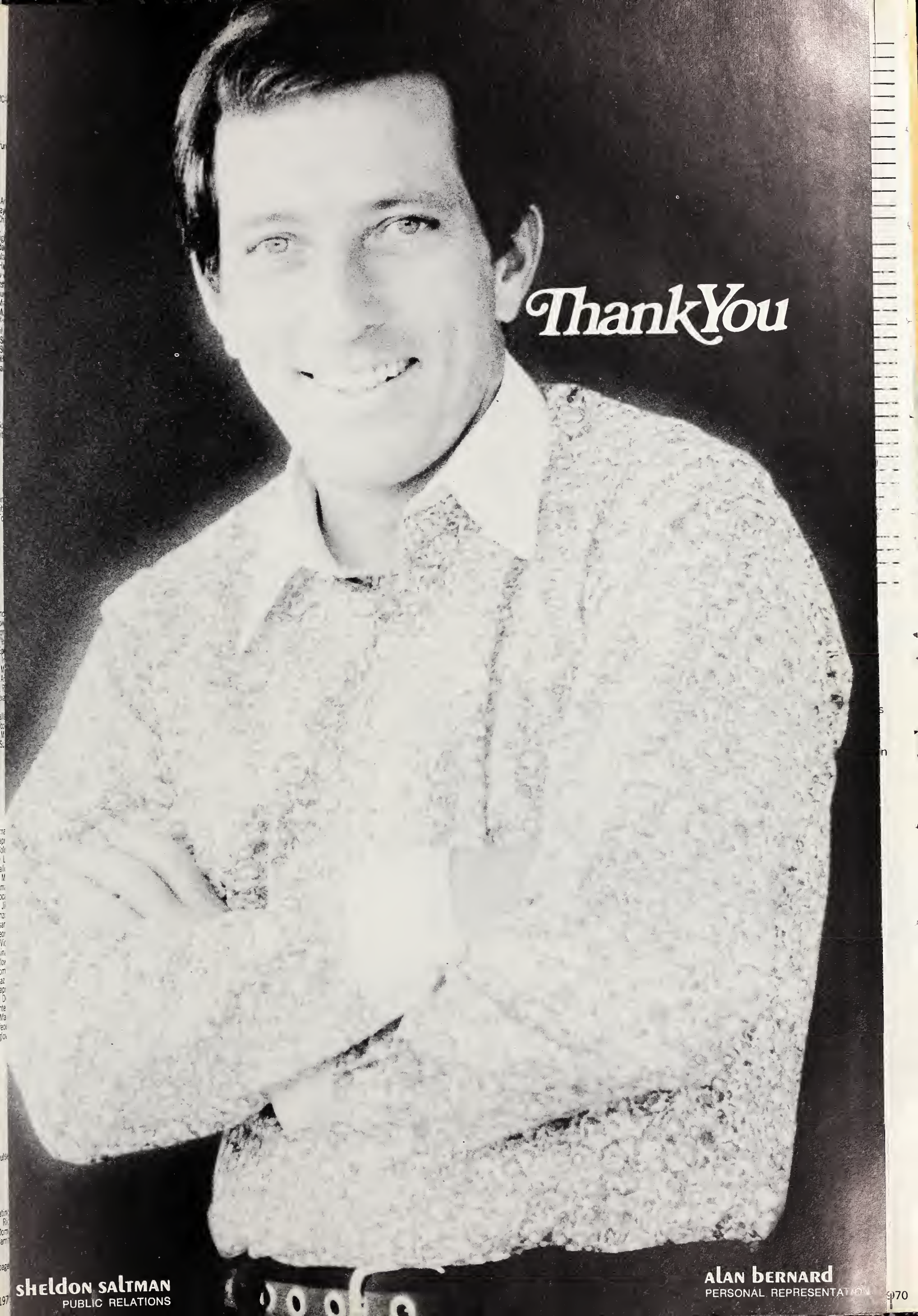

*Thank You*

# Record Distributors

•NARM MEMBERS

**Cordova's Importers & Distributors (Con't)**

Gapoca, Hurricane, Ideal, Infal, Impacto, Lira, Magda, Marsol, Mex-Melody, Musart, Norteno, Nuevo, Orfeon, Paloma, Peerless, Rovi, Sombrero)  
 TAPE: (Bego, Bernal, Buena Suerte, Cap Latino, Del Rio, Del Sur, Del Valle, D.V.L., El Pato, El Zarape, Hurricane, Ideal, Impacto, Magda, Marsol, Mex melody, Musart, Norteno, Orfeon, Peerless)

**Huish Distributing Co.**  
 2525 South 8th West  
 Ross J. Davis 486-7611  
 (RCA, Camden, Victrola)  
 TAPE: (RCA, Camden)

**VIRGINIA**

**McLEAN (703)**

**Dance Records**  
 7915 Lewinsville Road  
 Dick and Sheila Mason 356-9113  
 (Gem, Dance Along, Hoctor, Roper, SMC, Windsor, Imports, Artone, CBS, IDTA, Joy, Liberty, MPS, Odeon, Oriole, Philips, Polydor, Silver Dollar, Starlite, Sydney Thompson, Eric Winston)

**RICHMOND (703)**

**Liberty/UA Dist. Corp.**  
 2111 Spencer Road  
 Adam Strickland 288-3053  
 (liberty, U.A., Bluenote, Soul City, Veep, Minit, Sunset, Unart, Imperial, World Pacific, World Pacific Jazz)

**WASHINGTON**

**SEATTLE (206)**

•**ABC Records & Tape Sales Corp.**  
 729 So. Fidalgo  
 Chuck Blacksmith 803-8600  
 (A & M, ABC, Acta, Aidart, Ampex, Apt, Ariel, Archive, Ascot, Atco, Atlantic, Bach Guild, Bamboo, Bang, Banyon Tree, Black Man, Blue Horizon, Blue Note, Vlu Thumb, Bluesway, Bravo, Brunswick, Bert & I, Berlitz, Brookly, B.T. Puppy, Buddha, Buluu, Cadet, Cardinal, Challenge, Checker, Chess, Coliseu, Colgems, Command, Colonial, Command Probe, Coral, Contemporary, Cobblestone, Crewe, C.R.I., Commonwealth United, Durtom, Decca, Deram, Deutsche Grammaphon, Diamond, Dionn, Disneyland, Dolton, Dooto, Dot, Douglas, Dandelion,

**ABC Record & Tape Sales Corp. (Con't)**

Dunhill, Dunwich, Dyno Voice, Dynamo, Elektra, Elephant, Enterprise, Event, Everyman, Fantasy, First Generation, Flying Dutchman, Focus, Fax, GTJ, Galaxy, Gold Star, Golden, Golden Nugget, Gordy, Gross, Heliodor, Hip, Hi, Hotwax, Hob, Imperial, Impulse, Intrepid, Jad, Jamie, Josie, Janus, Jubilee, Kama Sutra, Kirshnen, Klondike, Latenight, Laurie, Liberty, Little David, Limelight, Living Language, Living Literature, Lobo, Lizard, Loma, London, Lyra, Mercury, Metromedia, Minit, M.T.A., Mingus, Monument, Motown, Musicor, National General, Neptune, Nonesuch, Original Sound, Pace, Page One, Paramount, Parrot, Pavillion, Phil A Of Soul, Polydor, Pentagram, Pompeii, People, Poppy, Reprise, Radnor, Rare Earth, Revue, Richmond, Riverside, Roost, Royal American, Scepter, Shout, Skye, Solid State, S.G.C., Shamley, Smo Bro, San Francisco, Shelter, Sound Stage 7, Starday, Stax, Steed, Stormy Forest, Standard, Straight, Syntonic Research, Sussex, Symbolic, Sue, Super K, Tetragrammaton, Tico, Threshold, Toddlin Town, Twinight, Uni, United Artists, United Talent, USA, Vip, Vanguard, Vista, Viva, Volt, Vortex, Wand, Warner Brothers, West Bound, Weed, Yew)

•**Capitol Records Dist. Corp.**  
 5511 First Avenue  
 Bob Setzer  
 (Angel, Apple, Capitol, Seraphim, Invictus, Fame Trump)

•**Craig Corp.**  
 540 South Front Street  
 George Smith 803-2450  
 (Columbia, Date, Epic, Harmony, Kinetic, Fillmore, Immediate, Odyssey, Barnaby)

•**Fidelity Northwest Inc.**  
 5301 Shilshole Avenue Northwest  
 Wallis J. Tolles 784-9100  
 (Amaret, Amos, Audio Fidelity, Calla, Camden, Candide, Chart, Colgems, Conversaphone, Cottillion, Dakar, Fontana, Disneyland, Double Shot, Duke, Embryo, ESP, Excello, Firebird, Fontana, Four Corners, GRT, GWP, Gamble, Hip, International Artist, Kapp, King, Kirschner, LHI, Mercury Wing, Moira, Pacific Jazz, Philips, Poppy, Prestige, Ranwood, RCA, Ripcord, Silver Fox, Smash, Soul City, Turnabout, Vault, Victrola, Vox, Wayside, White Whale, World Pacific)  
 TAPE: (Ampex, Artia Parliament, Berlitz, Fontana, GRT, GWP, ITCC, Kapp, King, Mercury, NAL, Omega, Philips, Prestige, Project 3, RCA, Smash, Vox)

**Huffine Distributing Company**  
 3131 Western Avenue  
 Andy Huffine AT4-8633

(Amy, Audio Fidelity, Bell, Fiesta, GNP, scendo, Gordy, Hickory, Mala, Monitor, Mot Music, Minus One, Skye, Soui, TRX, Tamla)  
 TAPE: (Motown, Tamla, Soul, Gordy)

**WISCONSIN**

**MADISON (608)**

**Tell Music Distributors, Inc.**  
 1019 Jonathon Drive  
 Rolf V. Voegelin 271-2661  
 (A & M, Abnak, Accent, Amos, Ampex, Ath Blue Thumb, Buena Vista, Certron, scendo, Dearbon, Disneyland, Dandelion, ble Shot, Elektra, Evolution, Golden, Media, LHI, Nashville, Nonesuch, Ranw RPR, Starday/King, Stereo-Dimension, She White Whale)

**MILWAUKEE (414)**

•**Decca Distributing Corp.**  
 325 E. Chicago Street  
 Robert Blie 272-1086  
 (Berlitz, Bravo, Brunswick, Colonial, Coral, ca, MTA, Standard, Viva, CVocalion)

**Morley Murphy Co.**  
 5151 W. State Street  
 Gordon Krahan 453-7200  
 (Columbia, Date)  
 TAPE: (Columbia, Date)

**John O'Brien Distributing Inc.**  
 5825 North 96th Street  
 John F. O'Brien 462-5590  
 (Atlantic, Atco, Banyan Tree, Blue Rock, Cap Argo, Checker, Chess, Crimson, Diamond, namo, GNP/Checker, Gordy, Hi Fi/Life, Jamie, Guyden, Jewel Paula, Jansco, K Mainstream, Motown, Musicor, Pageant Pol Phil L.A. Soul, Plantation, Project 3, Roul Sundi, SSS International, Stax, Soul, Tar Time, Turn Table, Uni, Vip, Volt, Vortex)  
 TAPE: (Atlantic, Atco, Gordy, Motown, S Soul, Tamla, Volt)

•**Taylor Electric Company**  
 1000 W. Donges Bay Road  
 (Mequon)  
 Peter D. Stocke 241-4321  
 (RCA, Colgem, Kirschner, Poppy, Cuca, G Happy Time, Hickory, Hilltop, Janus, Little lin', Little David, Pickwick, Rare Earth, Request, Scepter (Wand/Hob/Mace), S Thunderbird, TRX, Westbound)  
 TAPE: (All Labels)

The Distributor That  
 Made Milwaukee Famous

TAYLOR ELECTRIC CO.

For

COMPLETE NO. ILLINOIS & WISCONSIN COVERAGE

Merchandising-Sales-Promotion  
 RECORDS & TAPES

TAYLOR ELECTRIC CO.

1000 W. Donges Bay Road; Milwaukee, Wisconsin

Peter D. Stocke, Gen. Mgr. (414) 241-4321 Jim Hanke, Sales Mgr.

Chip away sales  
 resistance in the  
 Philadelphia market

**Chips** DISTRIBUTING  
 2750 NORTH BROAD STREET PHILA PA 19132 (215) BA 6-4600

Pres.-Gen. Mgr.  
 Ernie Santone

Sales Mgr.  
 Mario Davlerio

Promotion:  
 Alex Arago • Jerry Armour  
 Ed Gilreach

Delaware Valley Leading Independent Distributors

**IN NEW JERSEY**

You will get the strong sales coverage and merchandising know-how of our professional staff

**ALL-STATE**

SHERMAN KOENIG Pres.

IRWIN FINK Vice Pres.

COMPLETE DISTRIBUTION & RACK JOBBING OF

RECORDS

4 & 8 TRACK TAPES

CASSETTES

**ALL-STATE, N. J., INC., 321 SHERMAN AVE., NEWARK, N. J. (201) 242-6500**



# Thank You One & All

THE MOST PROGRAMMED FEMALE VOCALIST 1970 CASH BOX DISC JOCKEY POLL

# DIONNE WARWICK

PRODUCED BY  
Burt Bacharach & Hal David

PERSONAL MANAGEMENT  
Paul Cantor

EXCLUSIVELY ON  
scepter records

# Rack Jobbers

## •NARM MEMBERS

### ALABAMA

M & F Record Suppliers  
4008 Dauphin Island Parkway  
Birmingham, Ala.—Fred Filippone

Music Center  
416 N. 19th St.  
Birmingham, Ala.

Victory Record Service  
1028 N. 1st Ave.  
Birmingham, Ala.—Joe Vetrano

Reliable Records  
1018 Christopher Ave.  
Gadsden, Ala.—C. R. O'Neal

Music City  
567 Houston St.  
Mobile, Ala.—Albert Pardo

•Rack Service Merchandisers  
3801 Moffit Rd.  
Mobile, Ala. 36618—Patricia Chambliss

### ARIZONA

•All Label Record Service  
708 E. Weldor  
Phoenix, Ariz. 85114—Jim Robidett

•Arc, Inc.  
2029 North Black Canyon Highway  
Phoenix, Arizona 85009—Marvin Grover

•Arizona Sundries Co.  
2949 N. 30th Ave.  
Phoenix, Ariz. 85017—George Souvall

•Arizona Western Supply  
2950 N. 30th Ave.  
Phoenix, Ariz. 85017—John Youmens

•Associated Distributors  
3803 North 36th Avenue  
Phoenix, Arizona 85019—Leonard Singer

•Transcontinental Music Corp.  
3036 N. 30th Avenue  
Phoenix, Arizona 85019—Jack Sharpe

### ARKANSAS

•Bill Fisher Auto Air Conditioning  
2905 Cantrell Rd.  
Little Rock, Ark. 72202—Wm. S. Fisher,  
Jr., Wm. S. Fisher, III

•Siebert's News Agency  
6301 Forbing Road  
Box 4375 Asher Station  
Little Rock, Ark.—Sieg Siebert  
David Siebert

### CALIFORNIA

•Transcontinental Music Corp.  
868 Cowan Road  
Burlingame, Calif. 94010—Wm. Hall

•Music West  
460 Talbert Ave.  
Daly City, Calif. 94014—Merritt B. Kirk

M&M Records  
295 N. Hartz Ave.  
Danville, Calif.—Gordon C. Gorge

•Musical Isle of America  
P.O. Box 8004  
1461 Park Ave.  
Emeryville, Calif. 94608—John Edgerton,  
Vern Cupples

•Western One Stop  
1461 Park Ave.  
Emeryville, Calif.

Western News Supply  
461 North Weber  
Fresno, Calif.—Bob Tenschler

Mel-Q-Disc Record Co.  
16228 South Ball St.  
Gardena, Calif.—Charles Burk

•NMC Corp.  
1535 Rosecrans Ave.  
Gardena, Calif. 90249—Bill Hanna

•Transcontinental Music Corp.  
15500 S. Main St.  
Gardena, Calif. 90061—Larry Nones,  
Frank Holland

•ABC Record & Tape Sales Corp.  
3334 La Cienega Place  
Los Angeles, Calif. 90016—Norman Larson

•Amexar  
3018 N. Pico Blvd.  
Los Angeles, Calif. 90006—Carlos Campbell

Julian Brown Enterprise  
9106 S. Western Ave.  
Los Angeles, Calif.  
Lorin Wilson—Lloyd Thompson

California Record Rack  
2933 W. Pico Blvd.  
Los Angeles, Calif.—Sam Ricklin

•Craig Corp.  
2302 E. 15th St.  
Los Angeles, Calif. 90021—Lauren C Davies  
Jack Baker

•Handleman Co.  
1550 N. Knowles Ave.  
Los Angeles, Calif. 90063—MoeHandleman

•Leader Sales  
3416 West Pico Blvd.  
Los Angeles, Calif. 90019—Len Silver

•Merchandise Promotions of America  
1348 Venice Boulevard  
Los Angeles, Calif.—Mildred Weiss

•Musical Isle of America  
6920 Sunset Blvd.  
Los Angeles, Calif. 90028—Ron Biedsoe  
Russ Bach

•Nehi Distributing Company  
2527 W. 9th Street  
Los Angeles, Calif. 90006  
Thomas M. Heiman

•Record Merchandising Co.  
2580 W. Pico Blvd.  
Los Angeles Ca. if. 90006—Sidney Talmadge

•Record Rack Service, Inc.  
5873 Rodeo Road  
Los Angeles 29, Calif.—Mal Talmadge

•West Coast Music Sales  
2833 W. Pico Blvd.  
Los Angeles, Calif. 90006—Joel Miller

•Modern Sound  
9321 Melvin Ave.  
Northridge, Calif. 98324—Roger Brown

Canterbury Records  
805 East Colorado  
Pasadena, Calif.

•Central Valley Record Racks  
Alhambra Jay Bldg. Suite #70  
Sacramento, Calif. 95816—Russell  
Solomon

•Musical Isle of America  
2147 Barstow St.—Bldg. B.  
Sacramento, Calif. 95815—John Le  
Compte

Contact San Diego  
345 Sixth Ave.  
San Diego, Calif. 92212—A. W. Jones

•Record Rack Service  
1340 E. St.  
San Diego, Calif.

•H. R. Basford Co.  
800 Mariposa Street  
San Francisco, Calif. 94107—Jack  
Solinger

•Musical Isle of America  
645 Bryant Ave.  
San Francisco, Calif. 94107—David  
Watson

•National Tape & Record Distributors  
324 Harbor Way  
So. San Francisco, Calif. 94080

Rapid Merch. Co.  
640 Army St.  
San Francisco, Calif.

Record Supply Dist.  
154 S. Van Ness Ave.  
San Francisco, Calif.

•Leader Sales  
666 J Stockton Ave.  
San Jose, Calif. 95126

•Barbary Coast  
612 South Railroad Ave.  
San Mateo, Calif.

•Record Rack Service  
612 Railroad Ave.  
San Mateo, Calif. 92101

•Ckid Merchandising Co.  
7421 Daimler St.  
Santa Ana, Calif.—92711—Herbert Sandel

•Music West  
19110 S. Vermont  
Torrance, Calif. 90502—Merritt B. Kirk

•National Record —Tape Distributors  
22433 S. Vermont  
Torrance, Calif.—Ralph Kaffel

•United Tape Corp.  
2433 S. Vermont  
Torrance, Calif. 90502

•Car Tapes, Inc.  
16725 Roscoe Blvd.  
Van Nuys, Calif. 91406—Gene Becker

•Bertel Distributing Company  
523 Victoria Ave.  
Venice, Calif. 90291

### CANADA

•Western Rack Services Ltd.  
120 W. Hastings  
Vancouver 3, British Columbia  
John MacMillan

•Handleman of Canada  
132 Halifax St.  
Moncton, New Brunswick—Emerson  
Rawding

•Kensington Wacol Sherman Distributors  
3109 American Drive  
Malton, Ont.—Alex Sherman

Fireco Sales, Ltd.  
33 Racine Road  
Rexdale, Ont., Canada  
Barney G. Ryan

•All Records Supply of Canada  
1149 Bellamy Rd.  
Scarborough, Ont.—Roy J. Perini

•EMI Ltd.  
446 Birchmount Rd.  
Scarboro, Ontario, Canada  
John Douglas MacMillan

Continental Rec. Co., Ltd.  
1244 Caledonia Rd.  
Toronto 19, Ont.

•Handleman Co. of Canada  
132 Manville Rd.  
Scarborough, Ontario, Canada—Robert  
Cipriani

•Handleman Co. of Canada  
1280 Montee De Liesse  
Ville, St. Laurent, Quebec—Serge  
Loundergo

•Waco Sherman Distributors  
9255 Cote DeLiesse Rd.  
Dorval 7bo  
Quebec

### COLORADO

•ABC Record 8 Sales Corp.  
10625 E. 47th Ave.  
Denver, Colo. 80239—Ted de Fleron

•Craig Corporation  
4959 Colorado Blvd.  
Denver, Colorado 80216—Alvie Bergam

J. L. Racks  
77 Kalamath St.  
Denver, Colo. 80223

•Music Merchandisers Of Denver  
3825 Newport  
Denver, Colo. 80207—S. Wm. Davis

Pan American Record Supply  
77 Kalamath St.  
Denver, Colo. Bill Turner—Paul Marcus

•Transcontinental Music Corp.  
1111 South Platte River Drive  
Denver, Colorado 80204—Earl Woolf

Jay Record Co.  
945 East Evans  
Pueblo, Colo.—Herb & Max Martin

### CONNECTICUT

Music City Co.  
959 State St.  
Bridgeport, Conn.—Bill Bileca

•Park Record Distributors  
275 Park Ave.  
East Hartford, Conn. 06108—Joel Roski

Trinity Records  
477 Park Ave.  
East Hartford, Conn.—Ed Di Nallo

Thompson Records, Inc.  
Box 101  
Quinebaug, Conn.

### DELAWARE

Delware News Agency  
9th & Locust St.  
Wilmington, Delaware—Stanley Borne

### DISTRICT OF COLUMBIA

•District Records, Inc.  
2146 24th Place NE  
Washington, D.C.—James Schwartz

Potomac Music & Record Service  
3746 10th St., N.E.  
Washington, D.C. 20017  
John Kmiec & Mike Mackucics

Richray Dists., Inc.  
2400 17th St., N.W.  
Washington 9, D.C.—D. Custer

### FLORIDA

Rack Merchandising  
413 Coral Drive  
Cape Coral, Fla. 33904—Frederick Bent

•Record Supply Co.  
290 Iris Rd.  
Casselberry, Florida 32804—Richard N.  
Stultz

Kay Enterprises  
924 Old Federal Hwy.  
Hallandale, Fla. 33009—Ed Kay

•United Record & Tape Industries  
9880 N.W. 77th Avenue  
Hialeah Gardens, Florida  
Allan Wolk, Morton Marks

•Transcontinental Music Corp.  
684 North Edgewood Avenue  
Jacksonville, Florida 32205—Louis Rice

•Brooke Distributors  
380 N.E. 67th St.  
Miami, Florida 33138  
Manny Brookmire, Seymour Brookmire

Budisco One Stop  
280 N.W. 29th St.  
Miami, Fla.

•Transcontinental Music Corp.  
8160 N.W. 36th Avenue  
Miami, Florida 33147—Ed Chapman

(Cont'd on Page 110)

# **Reb Foster Associates manage to fill the Forum twice a year.**

**Steppenwolf and Three Dog Night.**

# Rack Jobbers

## •NARM MEMBERS

### FLORIDA

Hicks News Agency  
1316 N. Palm Ave.  
Ocala, Fla.—Clarence Hicks

•Handleman Company  
2346 N.W. 147th St.  
Opa Locka, Florida 33054—George Rosenjack

Orange News Co.  
122 Canal St.  
Tallahassee, Fla.

Tampa Records  
P.O. Box 5524  
Tampa, Fla. 33605—S. Delgado

D & M Post Cards & Records  
5011 Georgia Ave.  
West Palm Beach, Fla.—Don Ebbert

### GEORGIA

•ABC Record 8 Tape Sales Corp.  
720 14th Street NW  
Atlanta, Ga. 30318—Jack Geldbart

•Brooke Distributors  
2217 Faulkner Rd., NE  
Atlanta, Ga. 30324—Steve Brookmire

Budget Merchandising  
207 Walker St. SW  
Atlanta, Ga.

•Gate City Record Service  
1073 Huff Rd., NW  
Atlanta, Ga. 30318—Gerald Friedman & Ted Pousman

•Godwin Distributing Co.  
1270 Tacoma Drive  
Atlanta, Ga. 30318—Arthur Godwin

•National Record 8 Tape Corp.  
2201 Faulkner Rd., NE  
Atlanta, Ga. 30324—Michael King

•Continental Service Distributors  
236 Murray Drive  
Chamblee, Ga.—I. Sonny Friedman

•Stereo South  
2201 Faulkner Rd., NE  
Atlanta, Ga. 30324—Michael King

•Transcontinental Music Corp.  
660 Great Southwest Parkway  
Atlanta, Ga.—Ed Turlington

Clarkesville Record Sales  
608 N. Washington St.  
Clarkesville, Ga.—Peter Rosetty

Joe Head Prod.  
P. O. Box 291  
Mableton, Ga.—Joe Head

•Handleman Company  
1532 Stone Ridge Drive  
Stone Mountain, Georgia 30083  
John Langlois

### HAWAII

•Rack Service Hawaii  
2320 S. King St.  
Honolulu, Hawaii 96814—Don Ayers

### ILLINOIS

•ABC Record 8 Tape Sales Corp.  
P.O. Box 66186  
Chicago, Ill. 60606—Leonard Garmisa  
Harry Beckerman

•All State Record Dist.  
3035 W. 47th St.  
Chicago, Ill. 60632  
Paul J. Glass, Lee Howard

•All Tapes Distributing Co.  
2623 N. Pulaski Ave.  
Chicago, Ill. 60639  
Kent Beauchamp  
Edward Yalowitz

•Car Tapes, Inc.  
320 West Ohio Avenue  
Chicago, Ill.—James Levitus

Consolidated Record Sales  
101 S. Cicero Ave.  
Chicago 44, Ill.

•Crescent Music Corp.  
831 S. Wabask Ave.  
Chicago, Ill. 60605—Jack Rotner, Randy Blake

•Galgano Distributing Co.  
4135 W. Armitage Avenue  
Chicago, Ill. 60639—Anthony Galgano

•Hit Records  
10614 S. MacKinaw  
Chicago, Ill. 60617—Charles Stevens

•Mid-America Specialty Dist.  
4025 N. Ravenswood  
Chicago, Illinois 60613  
Howard Rosen

Mr. "T's" Volume Record Sales  
1729 E. 87th St.  
Chicago, Ill. 60617—Max Tannebaum

R & R Record Dist.  
7059 W. Addison St.  
Chicago, Ill.—Richard Sundling

•Stewart Sales Co.  
831 S. Wabash Ave.  
Chicago, Ill. 60605—Jack Rotner, Murray Blake

•Ruby Sales  
4038 W. Armitage Ave.  
Chicago, Ill. 60639—Reuben Lawrence

•Tape Distributors of America, Inc.  
3035 W. 47th St.  
Chicago, Ill. 60632  
Paul Glass, Lee Howard, Morton Ohren

•World Record Distributors  
2317 South Michigan Avenue  
Chicago, Ill. 60616  
Morris Goldstein

•Transcontinental Music Corp.  
5301 Danshere Rd.  
Country Side, Ill. 60525—Matt Edwards

Paul Allen Rack Sales  
111 Sun Valley Court  
East Peoria, Ill. 61614—Paul Duncan

•ABC Record and Tape Sales Corp.  
120 King Street  
Elk Grove Village, Illinois 60007  
Mailing Address: P.O. Box 66186  
Chicago, Illinois 60666 O'Hare)

•Handleman Company  
3477 Touhy Avenue  
Lincolnwood, Ill. 60645  
Hal Scovill

•Musical Isle of America  
7901 N. Caldwell  
Morton Grove, Ill. 60053—Victor Faraci

Paul Allen Rack Sales  
111 Sun Valley Ct.  
Peoria, Ill. 61614

R&R Record Distributors  
313 Franklin St.  
Peoria, Ill.—Ronald Salpeitro

The Record Bar  
109 N. Glendale Ave.  
Peoria, Ill.

•Susan Distributing Co.  
7330 Niles Center Rd.  
Skokie, Ill. 60076—Harry Lask

•Universal Music Mdsrs.  
9047 Terminal  
Skokie, Ill. 60076—Joe Weiss

### INDIANA

•Car-Tape Distributors  
211 East State Street  
Fort Wayne, Indiana 46805  
Robert Carteaux

Midwest Dist.  
123 McKinnie  
Fort Wayne, Indiana 46806

Tri-State Dist.  
933 Nuttman Ave.  
Fort Wayne, Ind.  
Indiana Merchandise Co.

•Associated Distributors, Inc.  
210 South Meridian St.  
Indianapolis, Ind.—L. E. Randle, Jr.

### IOWA

Iowa News  
115 7th S.E.  
Cedar Rapids, Iowa—Stanley Speidler

•ABC Record & Tape Sales Corp.  
1520 Walnut St.  
Des Moines, Iowa 50309—Jack Silverman

•J.L. Marshof Iowa, Inc.  
1630 Locust Street  
Des Moines, Iowa 50308—Jack Mishler

### KANSAS

•Transcontinental Music Corp.  
P. O. Box 517  
Wichita, Kansas 66106—Aileen Browing

### KENTUCKY

A. J. Eyl Co.  
Industry Road  
Lexington, Ky.

•Handleman Company  
4500 Louisville Ave.  
Louisville, Kentucky 40209—Fred Cart

•Mid America Specialty Distributors  
1450 S. 10th St.  
Louisville, Ky—John Julian

Peyton's Inc.  
716 W. Main St.  
Louisville 2, Ky.

Joy Record Co.  
P. O. Box 126  
Midway, Ky. 40347—Bill Buster

### LOUISIANA

Top Rak Record Service  
524 Lafayette St.  
Gretna, La.

Record Rack Sales  
P. O. Box 10386  
Jefferson Parish, La.

•Musical Isle of America  
P. O. Box 3727  
Lafayette, La. 70501—George Berry

•Hel-Lo Record Co., Inc.  
710 Aris Ave.  
Metairie, La.—Vincent Lofaso

•Rack Service Company  
P. O. Box 4727  
Monroe, La. 71201—Harold Chambliss

•Musical Isle of America  
757 Central Ave.  
New Orleans, La. 70121—George Berry  
Rose Simone

### MAINE

•The Boyd Corp.  
84 W. Cove St.  
Portland, Maine 04101—C. Roy Rice

Caron Co.  
73 India St.  
Portland, Maine—Jules Abramson

Diamond Corp.  
212 Anderson St.  
Portland, Maine

•Portland Records  
84 West Cove St.  
Portland, Me. 04101—C. Roy Rice

### MARYLAND

Atlas Record Rack (Div. of General Distr  
Co., Inc.)  
2329 Pennsylvania Avenue  
Baltimore, Maryland 21217

B & D Music  
2342 E. Monument St.  
Baltimore, Md.—Bill Gerhardt

•D&H Dist. Co. Inc.  
2025 Worchester St.  
Baltimore, Md.—Julius Rainess,  
Lester Pyle

•Ellis Distributing Co.  
5216 Fairlawn Ave.  
Baltimore, Md.—Edgar Ellis

Jalen Amusement Co., Inc.  
1215 South Howard St.  
Baltimore, Md. 21230—J. Jones

•Stacey Distributing Co.  
1101 DeSoto Road  
Baltimore, Md.—Ed Fitch

•D & H Distributing Co.  
2500 Shuster Drive  
Cheverly, Md. 20781—George Nesline

•Tape Merchandising Associates  
Jarrettsville Rd.  
P. O. Box 218  
Forest Hill, Md. 20151—Robert Green,  
Wm. Blau

•Interstate Record Distributors  
211 South Locust St.  
Hagerstown, Md. 21740  
Richard & Melvin Greenwald

(Con't on Page 112)

## MANY SERVICES for the RACK JOBBER

- ★ ALL TYPES OF INDEX STRIPS
- ★ BACK-UP CARDS FOR 45 RPM's
- ★ WHITE and VELVA-GLO KLEEN-STIK PRICE LABELS
- ★ HOT STAMPED DIVIDER CARDS for 45's or LP's

**TAILOR MADE FOR YOUR NEEDS.** Send for a Complete Brochure.

### STAR TITLE STRIP COMPANY, INC.

842 WESTERN AVENUE Area Code 412 231-4314 PITTSBURGH, PA. 15233



*Thank You  
For A  
Great Year*

*Brook  
Benton*



*Management: Alfred Rosenstein, N. Y. C.  
Bookings: William Morris Agency, N. Y. C.*

9  
60  
0  
64  
60  
69  
js  
on  
970

# Rack Jobbers

## •NARM MEMBERS

### MARYLAND

•Transcontinental Music Corp.  
333 Marshall Ave.  
Laurel, Md. 20810—Lawrence Goldberg

Coronet Music  
4724 Bonnie Brae Rd.  
Pikesville, Md. 21208—Sam Anoff

•Chase Marketing  
12160 Parklawn Drive  
Rockville, Md. 20852—Jack Black

### MASSACHUSETTS

Boston Record Dist.  
150 Vernon St.  
Boston, Mass. 02120—Jerry Flatto

•Disco Inc.  
339 Broadway  
Boston, Mass. 02149—Fred Traub

Boyd Corp.  
33 Moulton St.  
Cambridge 38, Mass.—James Boyd II

•Temple Sales, Inc.  
359 Washington St.  
Malden, Mass. 02148  
Richard Siegal, Michael Driscoll

•Handleman Company  
204 New Boston St.  
No. Woburn, Mass. 01801—Roy Stevens

U. S. Records  
185 Riverside Ave.  
Somerset, Mass.—Dan Gittleman

Alan Sales Co.  
45 Stoughton Ave.  
Webster, Mass. 01570—John Stularczy

•Transcontinental Music Corp.  
30 Nashua St.  
Woburn, Mass. 01801  
Glenn Mosley

### MICHIGAN

•ABC Record and Tape Sales Corp.  
15333 Livernois Avenue  
Detroit, Michigan 48238

•Auto Sound Dist. Co.  
20232 Livernois Ave.  
Detroit, Mich. 48221—Jack Frankford

•Consolidated One Stop, Inc.  
13254 Linwood  
Detroit, Mich. 48238  
Charles Gray, Thomas Mutter

•Handleman Co.  
670 E. Woodbridge  
Detroit 26, Mich.  
David Handleman—David Strome

•Raven Record Distributors  
13223 Harper Ave.  
Detroit, Mich. 48213—John Geiser

•Royal Stereo Tapes  
2950 West Davison  
Detroit, Michigan 48238  
Stan Byrd

Monroe Dist. Co.  
2431 Clyde Park S.W.  
Grand Rapids, Mich. 49509

•Handleman Co.  
4604 North East Street  
Lansing, Michigan 48906  
Ed Griesmer

McGregor News  
212 W. Michigan  
Mount Pleasant, Mich.

Publisher News  
U.S. at Grand Beach  
New Buffalo, Mich.

Cornell Records  
13380 Capitol Ave.  
Oak Park (Detroit), Mich.—Harry Levin

### MINNESOTA

•Bigelow Sales Co.  
11950 12th Avenue South  
Burnsville, Minn. 55378  
Bob & Niles Bigelow

•Select-O-Rax  
6930 Rosemary Rd.  
Hopkins, Minn. 55343  
Eugene C. Finch

•Acme Music Co.  
9549 Penn Avenue South  
Minneapolis, Minn. 55431  
David Lieberman, Richard Moerbitz

•Dart Records  
730 Lyndale Ave. N.  
Minneapolis, Minn.—Jack Taylor

Dasco, Inc.  
410 12th Ave. N.  
Minneapolis, Minn.—Ken McGowan

•Lieberman Enterprises  
9549 Penn Ave. So.  
Minneapolis, Minn. 55431  
Dave Lieberman

•J.L. Marsh Co.  
7600 Wayzata Blvd.  
Minneapolis, Minn. 55426  
Dan & Arnos Heilicher

•Rapid Merchandising Co.  
8175 Lewis Road  
Minneapolis, Minn. 55427

### MISSISSIPPI

Record Rak, Inc.  
110 Rear Cedars of Lebanon Road  
Jackson, Miss.—John Reeves

### MISSOURI

•ABC Record & Tape Sales Corp.  
2901 Grand Ave.  
Kansas City, Mo. 64108—Dave Berlau

Kansas City News Dist.  
4231 E. 75th Terrace  
Kansas City, Mo. 64132

•J.L. Marsh of Kansas City  
3230 Roanoke Rd.  
Kansas City, Mo. 64111  
Larry Cerninsky

•National Auto Sound  
5319 Troost Ave.  
Kansas City, Mo. 69110—Carl Galler

•Recco, Inc.  
1306 W. 39th St.  
Kansas City, Mo.—S. Harvey Laner

•Recco Dist. Co.  
4931 S. Benton  
Kansas City, Mo.

Boothel Music  
203 S. Main St.  
Kennett, Mo.  
Dick Hillburs, John McMullan

•Handleman Company  
1125 Saline St.  
North Kansas City, Mo. 64116—  
Frank Rochman

•CMC Records 8 Tapes  
Lindberg—Warson Ind. Ctr.  
1201 Research Blvd.  
St. Louis, Mo. 63132—B.A. Northrop

•J.L. Marsh Co. of Missouri  
2020 Delmar Blvd.  
St. Louis, Mo. 63103—Norman Hausfater  
Norman Wienstroer

•Musical Isle of America  
1815 Locust St.  
St. Louis, Mo. 63101—Norman Hausfater  
Norman Wienstroer

•NMC Corp.  
1906 Washington Ave.  
St. Louis, Mo.

•Richmark Sales Company  
4500 Woodson Rd.  
St. Louis, Missouri 63134  
James A. White

### MONTANA

Playhouse Inc.  
1015 Poplar  
Helena, Montana—Ben Hopkins

### NEVADA

Music City Rocks Of Nevada  
5409 Gypsy Ave.  
Las Vegas, Nevada—Alex Fox

•Musical Isle of America  
1524 Matley Lane  
Reno, Nevada—D. Jones

### NEW HAMPSHIRE

Sullivan News  
9 Odd Fellows Ave.  
Concord, N.H.

Verham News  
75 Main St.  
W. Lebanon, N.H.

### NEW JERSEY

•ABC Records Tape Sales Corp.  
29 Olney Avenue  
Building 29  
Cherry Hill Industrial Center  
Cherry Hill, New Jersey 08034

A.L. Fairbanks  
Record Distributors  
1050 Sherman Ave.  
Elizabeth, N.J.—Frank Arace

•Chancellor Electronics  
8 Spielman Rd.  
Fairfield N.J. 07006  
Sidney Koenig; Joel Koenig

•New Jersey One Stop  
Hillside Industrial Center  
467 Mundet Place  
Hillside, N. J. 07205  
Joseph Martin, Jerry Cohen, Ed Gries

Metropolitan Supermarket Services  
1601 W. Edgar Rd.  
Linden, N. J.—Charlie McAllister

•National Tapes & Records  
609 Commerce Rd.  
Linden, N. J. 07036—Robert Fleck

•National Merchandising Services  
Stokes Road  
Medford, New Jersey 08055  
Larry Coughan

•Rapid Merchandising Co.  
200 Pond Avenue  
Middlesex, N. J. 08846  
Ronald Mills

•All-State Records, Inc.  
321 Sherman Ave.  
Newark, N. J. 07114—Sherman Koenig

•J And J Corporation  
333 Clinton Place  
Newark, N. J. 07112  
Jay Jennis, Irwin Jennis

Market Merchandisers Inc.  
14-20 Wharton St.  
Newark, N. J.

•Atlas Rand Corp.  
2 Keystone Place  
Paramus, N. J. 07652—Richard Price  
Howard Rosen

•ABC Record & Tape Sales Corp.  
7025 Colonial Highway  
Pennsauken, N. J. 08109—Harry Jacobs

•Handleman Company  
7135 Colonial Lane  
Pennsauken, N. J. 08109  
Micael Goldwasser

•Garden State Record Dist.  
68 West Passaic St.  
Rochelle Park, N. J. 07662  
Stanley M. Sterling

Allied Record Sales  
1001 Hamilton Ave.  
Trenton, N. J. 08629  
John T. Gervasoni—Frank Romano

•Wellington Eight Industries  
1721 N. Olden Ave.  
Trenton, N. J. 08618  
Irving Rosenberg; Donald Zimmer

### NEW YORK

•Transcontinental Music Corp.  
100 Watervliet Ave.  
Albany, New York 12206  
Charles H. Schlang

•Almor Playtime Co. Inc.  
P.O. Box 111  
Amsterdam, N.Y.—Albert Hyman

All Record Dist.  
35-05 Broadway  
Astoria, L.I. C., N.Y.—Micael Lajacomo

Gemini  
2364 Legion St.  
Bellmore, N.Y.—11104—Norm Seema

G&G Record Dist.  
3 Bellevue Heights  
Binghamton, New York 13905

B&R Record Dist.  
1029 East 163rd St.  
Bronx, N.Y.—Jack Baum

Ken Glassman  
R. O. C. Record Co.  
1309 E. L. Grant H'way  
Bronx, N.Y. 10452—S. Sahler

•Fine Tone Audio Prod.  
24 Cobek Court  
Brooklyn, N.Y. 11223  
Leonard Finkel, Albert Stein

Kape International  
Box 74 R  
Brooklyn, N.Y. 11234

•Met Richmond Record Sales  
723 E. 81st St.  
Brooklyn 36, N.Y.—David Last

Rack Profits  
24 E. 52nd St.  
Brooklyn, N.Y.—Sy Friedman

•Sutton Record Co.  
2425 McDonald Ave.  
Brooklyn, N. Y. 11223  
Charles Sutton

•Pleasure Products Sales Corp.  
861 Washington St.  
Buffalo, N. Y. 14203—Carl Glaser

Transcontinent Record Sales  
961 Main St.  
Buffalo, N. Y.  
Leonard Silver, Steve Brodie

Tak-A-Toy Inc.  
102-05 Northern Blvd.  
Corona, N. Y.—Jack Israel

Bocar Sales  
124 W. 10th St.  
Deer Park, L. I., N. Y.

William Bernstein  
Guy Barry Ent.  
13 Wesley Drive  
East Rockaway, N. Y.

•Double B Records and Tape Corp.  
240 East Merrick Road  
Freeport, L. I.—Bernard Boorstein

•Candy Stripe Records  
17 Alabama Ave.  
Island Park, N. Y. 11558—Bernard Keil

•ABC Record & Tape Sales Corp.  
46-50 54th Ave.  
Maspeth, N. Y. 11378—Lou Klaymon

•Merco Enterprises, Inc.  
536 Broadhollow Road  
Melville, New York 11746  
Jack Grossman; Warren Rossman;  
Sol Gleit

•Steadman Sales  
200 S. 14th Ave.  
Mount Vernon, N. Y. 10550

•Alpha Distributors  
20 West End Avenue  
New York, N. Y. 10019  
David King

•Arovax Record Corp.  
239 West 18th St.  
New York, N.Y. 10011  
Ervin Litkei, John Haydu

(Con't. on Page 11)



RCA RECORDS  
AND  
BOND & GORDON ENTERPRISES

PROUDLY ANNOUNCE THEIR ASSOCIATION WITH

PAPA-NES  
P.K.A.

MICHAEL NESMITH  
& THE FIRST NATIONAL BAND



NEAT, HUH?

THE FIRST ALBUM, MAGNETIC SOUTH / LSP-4371

RCA

WE SINCERELY WISH TO THANK OUR MANY FRIENDS IN THE INDUSTRY  
FOR MAKING THIS AWARD POSSIBLE.

# Rack Jobbers

## •NARM MEMBERS

### NEW YORK

•Brun International Recotape Corp.  
460 W. 34th St.  
New York City, N.Y. 10001  
Jack Silverman

Independent Record Promotions  
101 8th Ave.  
New York, N. Y. 10011—Larry Schaffer

•Interstate Record Dist.  
1290 Ave. of Americas  
New York, N. Y. 10019—Manny Wells

National Record Sales  
160 Broadway  
New York N. Y. 10038—R. M. Jervis

•NMC Corp.  
235 W. 46th St.  
New York City, 10036—Tom White  
Ted Shapiro

•Olympia Distributing Co.  
239 West 18th St.  
New York City, N. Y. 10011  
Ervin Litkei

•Record Shack  
2132 Second Avenue  
New York City, N. Y. 10029  
Edward Portnoy

•Transcontinental Music Corp.  
201 E. 42nd St.  
New York City, N. Y.  
Arnold Greenhut, Howard Weingrow

•Win Records  
858 Ninth Ave.  
New York, New York 10019  
George & Sam Weiss

•NMC Corporation  
3580 Oceanside Rd.  
P.O. Box 70  
Oceanside, N. Y. 11572  
Jesse Selter; Maxwell Friedberg;  
Irving Glasser

•Toy House Of Hudson Valley  
Manchester Rd.  
Poughkeepsie, N. Y. 12603—Lou Kustas

Finger Lake Home Mdse. Co.  
240 Hemingway Dr.  
Rochester, N. Y.

Universal Record Sales  
1326 Clinton Ave. N  
Rochester, N. Y.

•Almor Co.  
207 Irving Ave.  
Syracuse, N. Y.

### NORTH CAROLINA

Alexander News Co.  
25 Carolina Lane  
Asheville, N.C.  
Clarence Shuttle—William Alexander

•BIB Distributing Company  
P.O. Box 1812  
Charlotte, N. C. 28201—Joseph Voynow

C & M Distributing Co.  
100 Southside Drive  
Charlotte, N. C.—Ted Conder

•Handleman Company  
2309 Dunavant  
Charlotte, N. C. 28203  
Bill Hanson

•S & P Records, Inc.  
3127 South Blvd.  
Charlotte, N. C. 28203—James Smith

Southeastern Record Merchandisers  
P.O. Box 1697, 2706 Freedom Dr.  
Charlotte, N. C.

•Dixie News Co.  
2100 Freedom Dr.  
Charlotte, N. C. 28208  
Tim Braswell, Jim McGinnis

•Modern Sound  
106 Campus Ave.  
Raeford, N. C. 28376—Thomas J. Malia

Rocky Mount News  
2900 S. Church Ave.  
Rocky Mount, N. C.

J. B. Armstrong News  
601 South Broad St.  
Winston Salem, N. C.

### OHIO

Associated Records  
101 S. Union  
Bedford, Ohio

Album Record Sales of America  
6566 Montgomery  
Cincinnati, Ohio—LeRoy Goodlander

Joyce Dist.  
1111 Paxton  
Cincinnati, Ohio

K. C. Dist.  
4508 Homer St.  
Cincinnati 27, Ohio

•All Label Record Service  
7777 Exchange St.  
Cleveland, Ohio 44125—Hess Budin

•Handleman Co.  
6116 Broadway  
Cleveland 27, Ohio—Carl Lombardo

•Main Line Record Service  
1260 E. 38th St.  
Cleveland, Ohio 44114—James Shipley

•Mid West Music  
2150 Hamilton Ave.  
Cleveland, Ohio—Ronald Schafer

Modern Record Rack Service  
1958 E. 101 St.  
Cleveland 8, Ohio—J. W. Burke

•North American Music Corp.  
2797 Hamilton Ave.  
Cleveland, Ohio 44114—Charles Murray

Universal Music  
5270 Euclid Ave.  
Cleveland, Ohio

John J. Getreu & Son Inc.  
212 N. 12th St.  
Columbus 15, Ohio

•Superior Tapes & Mobile Supply  
1705 Woodland Ave.  
Columbus, Ohio 43219  
Harry Zucherman

•Handleman Company  
13900 Broadway  
Garfield Heights, Ohio 44125  
Robert Prenatt

•Stark Record Service  
8000 Freedom Avenue N. W.  
North Canton, Ohio 44720  
Paul David

•Dayton Record Service  
24 Union Street  
Portsmouth, Ohio 45662  
Wilburn Carrington; Joe Taylor

•Service Dist.  
24 Union St.  
Portsmouth, Ohio—Wilburn Carrington  
Joe Taylor

•Buckeye Enterprises  
44 Warder Street  
Springfield, Ohio 45504  
Asen Kristoff

Hoffman News Agency  
25 W. Washington Ave.  
Springfield, Ohio

Bartley Co.  
921 Brown Ave.  
Toledo, Ohio—Richard Bernard

Northwest Dist.  
1020 Sylvania Ave.  
Toledo, Ohio—George LaCorse

•Mid America Specialty Distributors  
1028 W. Rayen  
Youngstown, Ohio 44502  
Felix Lazazerra

### OKLAHOMA

•Communication Electronics  
7501 N. Broadway  
Oklahoma City, Okla. 73114  
Tommy Haskall; Richard Hainebuch

•Mild Continent News Co.  
7001 N. Broadway Expressway  
Oklahoma City, Okla. 73103  
C. Albro

Southwest Dist. Co.  
1159 Madison Ave.  
Oklahoma City 3, Okla.  
Ken Hensley—M. Woddruff

•Western Merchandisers  
133 N. W. 23rd St.  
Oklahoma City, Okla.

•Oklahoma News Co.  
909 W. 22nd St.  
Tulsa 7, Okla.  
Glenn White 74107—Stan White

### OREGON

McDonald Candy Co.  
2250 W. B'way  
Eugene, Ore.

Patty Day Inc.  
326 N. River Rd.  
Milwaukee, Ore.

Julian Brown Enterprise  
3560 N. E. Kinningsworth  
Portland 11, Ore.—Wm. G. Blackburn

•Souval Bros. of Portland  
9300 N. E. Multnomah  
Portland, Ore.

Paul Jackson Co.  
1308 N. W. Park St.  
Roseburg, Ore.

### PENNSYLVANIA

Rec O Rac  
1011 Baltimore Ave.  
East Landsdowne, Pa.—Harry Blaufield

E. P. Records Of Erie  
3103 Garland St.  
Erie, Pa.

Record Bar Rock  
1127 State St.  
Erie, Penna.

•D & H Dist. Co., Inc.  
P. O. Box 1967  
Harrisburg, Pa. 17105—David Press

•Richmark Sales Co.  
1072 Lincoln Highway West  
Irwin, Pa. 15642—Alvin Ackerman

Lebanon News Agency  
33 N. 8th St.  
Lebanon, Pa.

•Handleman Company  
1388 Island Ave.  
McKees Rocks, Pa. 15212  
Vera Powell

Triangle News Co.  
301 Muson Ave.  
McKees Rocks, Pa.—George Fine

Michael Adler Ent.  
6720 Broad St.  
Philadelphia, Pa. 19126—Joe Brodsky

•Bandstand Record Service  
1400 W. Somerset St.  
Philadelphia, Pa.—Phil Slavin

•Continental Service Dist.  
4041 Ridge Ave.  
Philadelphia, Pa. 19128  
Sylvan Gross; Paul Gross

•Raymond Rosen Music Products  
51st St. and Parkside Ave.  
Philadelphia, Penna. 19131  
Alfred Rosenthal

Shulman Distributors  
428 N. 13th St.  
Philadelphia, Pa. 19123  
Jerry Shulman

•Mid America Specialty Dists.  
2725 Brownsville Rd.  
Pittsburgh, Pa. 15227  
John Hoebler

John Robert Co.  
5222 Centre Ave.  
Pittsburg, Pa. 15232—Don Bray

Mid-Penn News Agency  
100 Eck Circle  
Williamsport, Pa.—C. Mayer

### RHODE ISLAND

H. V. Papazian & Co.  
803 Broadway  
East Providence, R.I.—Harold V. Papazian

•ABC Record & Tape Sales Corp.  
725 Brauch St.  
Providence, R.I. 12904—Milton Israel

### SOUTH CAROLINA

•Brown Sales Co.  
1423 Ellerbe St.  
Columbia, S.C.—Grady Brown

### TENNESSEE

•Knox Record Rack Co.  
1539 Amherst Rd.  
Knoxville, Tenn. 37921—Sam Morrison  
Jay Jacobs

•Arthur Fulmer Co.  
P.O. Box 177  
260 Monroe Ave.  
Memphis, Tenn. 38101  
Arthur Fulmer Jr.

•Record Vending  
746 Galloway Ave.  
Memphis, Tenn. 38105—Sidney Melvin

•Record Vending, Inc.  
469 Chestnut St.  
Nashville, Tenn. 37203.—Launy Estes

Volunteer Dist. Co.  
1108 17th Ave.  
Nashville, Tenn.—Weber Parrish

### TEXAS

•Western Merchandisers  
1601 W. Third  
P.O. Box 1969  
Amarillo, Texas  
Dick Williamson—Ed Perry

•J.L. Marsh of Texas  
3107 Avenue "E" East  
Arlington, Texas 76010—Jim Scheckle

•Texas Tape Cartridge Corp.  
725 Great Southwest Parkway  
Arlington, Texas 76010  
Geo. M. Slaughter III

Nueces News  
414 S. Port  
Corpus Christi, Texas

•ABC Record & Tape Sales Corp.  
4841 Topline Drive  
Dallas, Texas 75247—Bill Pennington

•Handleman Co.  
2931 Irving Blvd.  
Dallas, Texas 75247  
George Braun

•Jay Kay Distributing Co.  
2931 Irving Blvd.  
Dallas, Texas, 75247—Marion Coburn

•Records Of Dallas Inc.  
1345 Chemical St.  
Dallas, Texas 75207—Bill Emerson

•Transcontinental Music Corp.  
4845 Cash Road  
Dallas, Texas  
Bruce Masterson

Trinity News  
1320 W. B'way  
P.O. Box 1806  
Ft. Worth 4, Texas—Louis Page

(Cont'd on Page 122)

*The  
Robert Stigwood  
Organization*



*Representing*

BEE GEES  
BARRY GIBB  
MAURICE GIBB  
ERIC MERCURY  
TASTE

ERIC CLAPTON  
GINGER BAKER  
JACK BRUCE  
BOBBY BLOOM  
ARCHIE WHITEWATER  
SLADE

CREAM  
JOHN MAYALL  
GEORGIE FAME  
TOE FAT  
FAT MATTRESS

*and*

R.S.O. PUBLISHING, INC.  
(ASCAP)

CASSEROLE MUSIC CORP.  
(BMI)

ST. GEORGE MUSIC  
(BMI)

MONTGROVE PRODUCTIONS  
(ASCAP)

GROOVESVILLE MUSIC  
(BMI)

*The Robert Stigwood Organization*

1700 BROADWAY / NEW YORK, N.Y. 10019 / (212) 765-7850

Rik Gunnell, Pres. / Norm Rubin, Gen. Mgr. / Bob Glasser, West Coast Rep.

# MILLION SELLERS

Alpert, Herb & Tijuana Brass	*This Guy's In Love With You	A&M 1968
American Breed	*Bend Me, Shape Me	Acta 1968
Ames Brothers	Sentimental Me (Rag Mop)	Carol 1950
	You You You	Victor 1953
Anderson, Leroy	Blue Tango	Decca 1951
Andrews Sisters	Rum And Coca-Cola	Decca 1944
	I Can Dream, Can't I	Decca 1949
Anka, Paul	Diana	ABC Par 1957
	Lonely Boy	ABC Par 1960
Archies	*Sugar, Sugar	Calendar 1969
	*Jingle Jangle	Kirshner 1970
Association	*Cherish	Valiant 1966
	*Never My Love	Warner Bros. 1967
	*Windy	Warner Bros. 1967
Austin, Gene	Ramona	Victor 1928
Autry, Gene	Silver Haired Daddy	Columbia 1939
	Rudolph The Red-Nosed Reindeer	Columbia 1969
Avalon, Frankie	Venus	Chancellor 1958
Baker, LaVern	I Cried A Tear	Atlantic 1959
Barber, Chris	Petite Fleur	Laurie 1959
Barron, Blue	Cruising Down The River	MGM 1949
Barton, Eileen	If I Knew You Were Comin' I'd Of Baked A Cake	National 1950
Baxter, Les	Poor People Of Paris	Capitol 1956
Beatles	*I Want To Hold Your Hand	Capitol 1964
	*Can't Buy Me Love	Capitol 1964
Beatles With Billy Preston	She Loves You	Swan 1964
	*A Hard Day's Night	Capitol 1964
	*I Feel Fine	Capitol 1964
	*Help!	Capitol 1965
	*Eight Days A Week	Capitol 1965
	*Yesterday	Capitol 1965
	*We Can Work It Out	Capitol 1966
	*No Where Man	Capitol 1966
	*Paperback Writer	Capitol 1966
	*Yellow Submarine	Capitol 1966
	*Penny Lane	Capitol 1967
	*All You Need Is Love	Capitol 1967
	*Hello Goodbye	Capitol 1968
	*Lady Madonna	Capitol 1968
	*Hey Jude	Apple Corps 1968
	*Something	Apple 1969
	*Let It Be	Apple 1970
	*Get Back	Apple 1969
	Bell, Archie & Drells	*Tighten Up
Bennett, Tony	Because of You	Columbia 1952
	Cold Cold Heart	Columbia 1952
	Rags To Riches	Columbia 1953
Benton, Brook	Stranger In Paradise	Columbia 1954
	It's Just A Matter Of Time	Mercury 1959
	*Rainy Night In Georgia	Cotillion 1970
Bilk, Mr. Acker	Stranger On The Shore	Atco 1962
Black's Combo, Bill	Smokie	Hi 1959
	White Silver Sands	Hi 1960
	Josephine	Hi 1960
Black, Jeanne	He'll Have To Stay	Capitol 1960
Blood, Sweat, & Tears	*You Made Me So Very Happy	Columbia 1969
	*Spinning Wheel	Columbia 1969
	*And When I Die	Columbia 1970
Bonds, Gary U.S.	Quarter To Three	Legrand 1962
Booker T & MG's	Green Onions	Stax 1962
Boone, Pat	Ain't That A Shame	Dot 1955
	I'll Be Home	Dot 1955
	Friendly Persuasion	Dot 1955
	Remember You're Mine	Dot 1956
	I Almost Lost My Mind	Dot 1956
	Love Letters In The Sand	Dot 1957
	Don't Forbid Me	Dot 1957
	Why, Baby, Why	Dot 1957
	April Love	Dot 1958
	*The Letter	Mala 1967
Boyd, Jimmy	I Saw Mamma Kissing Santa Claus	Columbia 1952
Brewer, Teresa	Till I Waltz Again With You	Coral 1952
	Ricochet	Coral 1953
Britt, Elton	There's A Star-Spangled Banner Waving Somewhere	Victor 1942
Brooklyn Bridge	*The Worst That Can Happen	Buddah 1969
Brown, Arthur	*Fire	Atlantic 1969
Brown, Les	Sentimental Journey	Columbia 1945
Browns	Three Bells	Victor 1959
Buchanan & Goodman	Flying Saucer	Universe 1956
Butler, Jerry	*Only The Strong Survive	Mercury 1969
Byrnes, Edd	Kookie Lend Me Your Comb	Warner Bros 1959

Calloway, Cab	Jumpin Jive'	Columbia 1939	
Campbell, Glen	*Wichita Lineman	Capitol 1969	
	*Galveston	Capitol 1969	
Carter, Clarence	*Slip Away	Atlantic 1968	
	*Too Weak To Fight	Atlantic 1969	
Channel, Bruce	Hey Baby	Smash 1962	
Cannon, Freddie	Way Down Yonder In New Orleans	Swan 1959	
Cash, Johnny	*A Boy Named Sue	Columbia 1969	
Cavallaro, Carmen	Polonaise (by Chopin)	Decca 1945	
Champs	Tequila	Challenge 1958	
Charles, Ray	*I Can't Stop Loving You	ABC Par 1962	
Chairmen Of The Board	*Give Me Just A Little More Time	Invictus 1970	
Checker, Chubby	The Twist	Parkway 1960	
	Let's Twist Again	Parkway 1961	
	Limbo Rock/Popeye	Parkway 1962	
Chordettes	Mr. Sandman	Cadence 1954	
Christie, Lou	*Lightnin' Strikes	MGM 1966	
Clark, Petula	*Downtown	Warner Bros. 1963	
Classics IV	*Stormy	Imperial 1969	
Clooney, Rosemary	Come On-A My House	Columbia 1951	
	Hey There	Columbia 1954	
Coasters	Searchin'	Atco 1957	
	Yakety Yak	Atco 1958	
	Charlie Brown	Atco 1959	
	Poison Ivy	Atco 1959	
Cole, Cozy	Topsy (Part II)	Love 1958	
Cole, Nat "King"	Nature Boy	Capitol 1948	
	Mona Lisa	Capitol 1949	
	Too Young	Capitol 1951	
	Ramblin' Rose	Capitol 1962	
Como, Perry	Temptation	Victor 1945	
	Hubba Hubba	Victor 1945	
	Till The End Of Time	Victor 1945	
	Prisoner Of Love	Victor 1946	
	When You Were Sweet Sixteen	Victor 1947	
	Because	Victor 1948	
	Don't Let The Stars Get In Your Eyes	Victor 1952	
	Wanted	Victor 1954	
	Hot Diggity	Victor 1956	
	Papa Loves Mambo	Victor 1956	
	Round And Round	Victor 1957	
	Catch A Falling Star	Victor 1958	
	Contours	Do You Love Me	Gordy 1962
	Cooke, Sam	You Send Me	Keen 1958
Covington, Warren	Tea For Two Cha Cha	Decca 1958	
Cowsills	*The Rain, The Park & Other Things	1968	
	*Hair	MGM 1969	
Cramer, Floyd	Late Date	RCA 1961	
Cream	*Sunshine Of Your Love	Atco 1968	
Crew Cuts	Sh-Boom	Mercury 1954	
Crickets	That'll Be The Day	Brunswick 1957	
Crosby, Bing	Silent Night	Decca 1942	
	Sunday, Monday, Or Always	Decca 1943	
	I'll Be Home For Christmas	Decca 1943	
	Swinging On A Star	Decca 1944	
	Too-Ra-Loo-Ra-Loo-Ra!	Decca 1944	
	I Can't Begin To Tell You	Decca 1945	
	Dear Hearts And Gentle People	Decca 1946	
	New San Antonio Rose	Decca 1946	
	MacNamara's Band	Decca 1946	
	Sweet Leilani	Decca 1946	
	White Christmas	Decca 1946	
	Now Is The Hour	Decca 1948	
	Galway Bay	Decca 1948	
	with Andrew Sisters	Pistol Packin' Mama	Decca 1943
	Jingle Bells	Decca 1943	
	Don't Fence Me In	Decca 1944	
	South America, Take It Away	Decca 1946	
with Gary Crosby	Play A Simple Melody	Decca 1950	
with Grace Kelly	True Love	Decca 1950	
with Fred Waring	Whiffenpoof Song	Capitol 1957	
Dalhart, Vernon	Prisoner's Song	Victor 1924	
Damone, Vic	You're Breaking My Heart	Mercury 1949	
Danny & Juniors	At The Hop	ABC-Par 1958	
Darin, Bobby	Spish Splash	Atco 1958	
	Dream Lover	Atco 1959	
	Queen Of The Hop	Atco 1959	
	Mack The Knife	Atco 1960	
Davis, Tyrone	*Can't I Change My Mind	Dakar 1969	
Davis, Tyrone	*Turn Back The Hands Of Time	Dakar 1970	
Day, Bobby	Rockin' Robin	Class 1958	
Day, Doris	Secret Love	Columbia 1954	
	Whatever Will Be, Will Be	Columbia 1956	
Dean, Jimmy	*Big Bad John	Columbia 1961	
Dee, Joey & Starlites	The Peppermint Twist	Roulette 1961	
Delfonics	*Didn't I (Blow Your Mind This Time)	Philly Groove	
Del-Vikings	Come Go With Me	Dot 1957	
Denny, Martin	Quiet Village	Liberty 1959	
Diamond, Neil	*Sweet Caroline	Uni 1969	
Diamonds	Little Darlin'	Mercury 1957	
	The Stroll	Mercury 1958	

(Con't on next Page)

# Chicago

Walter S. Parazaidis

Peter P. Cetera

James A. Fox

Robert W. Cannon

Daniel Maguire

Lee J. Longhorne

Henry Thott

# MILLION SELLERS

Dinning, Mark	Teen Angel	MGM 1960
Dion	Runaround Sue	Laurie 1961
	*Abraham, Martin & John	Laurie 1969
Doggett, Bill	Honky Tonk	King 1956
Domino, Fats	The Fat Man	Imperial 1948
	Goin' Home	Imperial 1952
	You Said You Loved Me	Imperial 1953
	Please Don't Leave Me	Imperial 1953
	Going To The River	Imperial 1953
	Love Me	Imperial 1954
	All By Myself	Imperial 1955
	I Can't Go On	Imperial 1955
	Ain't That A Shame	Imperial 1955
	I'm In Love Again	Imperial 1956
	Bo Weevil	Imperial 1956
	Blue Monday	Imperial 1956
	Bluberry Hill	Imperial 1956
	It's You I Love	Imperial 1957
	I'm Walkin'	Imperial 1957
	I Still Love You	Imperial 1957
	Whole Lotta Lovin'	Imperial 1960
Doors	*Light My Fire	Elektra 1967
	*Hello I Love You	
	*Touch Me	Elektra 1969
Dorsey, Jimmy	Maria Elena	Decca 1946
	Green Eyes	Decca 1946
	So Rare	Fraternity 1957
Dorsey, Tommy	Marie	Victor 1937
	Boogie Woogie	Victor 1938
	There Are Such Things	Victor 1942
Draper, Rusty	Gambler's Guitar	Mercury 1953
Drifters	There Goes My Baby	Atlantic 1960
	True Love, True Love/Dance With Me	Atlantic 1960
	Save The Last Dance For Me	Atlantic 1961
Duke Of Earl (Gene Chandler)	Duke Of Earl	Vee Jay 1962
Eckstine, Billy	I Apologize	MGM 1951
Edison Lighthouse	*Love Grows	Bell 1970
Edwards, Tommy	It's All In The Game	MGM 1958
Elegants	Little Star	APT 1958
Eva, Little	The Loco-Motion	Dimension 1962
Everly Bros.	Bye Bye Love	Cadence 1957
	Wake Up Little Susie	Cadence 1957
	All I Have To Do Is Dream	Cadence 1958
	Bird Dog/Devoted To You	Cadence 1958
	Cathy's Clown	Warner Bros. 1960
Fabric, Bent	Alley Cat	Atco 1962
Faith, Percy	The Song From Moulin Rouge	Columbia 1953
	*Theme From A Summer Place	Columbia 1960
Ferrante & Teicher	Exodus	Un. Artists 1961
Fiedler, Arthur	Jalousie	Victor 1938
Fifth Dimension	*Stone Soul Picnic	Soul City 1968
	*Aquarius/Let The Sunshine In Medley	Soul City 1969
Fisher, Eddie	Anytime	Victor 1951
	I'm Walking Behind You	Victor 1953
	Oh My Papa	Victor 1953
	I Need You Now	Victor 1954
Fitzgerald, Ella & Ink Spots	Into Each Life Some Rain Must Fall	Decca 1944
Fleetwoods	Come Softly To Me	Dolton 1959
	Mr. Blue	Dolton 1959
Fontane Sisters	Hearts Of Stone	Dot
Ford, Tennessee Ernie	Sixteen Tons	Capitol 1955
Foundations	*Build Me Up Buttercup	Uni 1969
Four Aces	Tell Me Why	Decca 1951
	Love Is A Many-Splendored Thing	Decca 1955
Four Lads	Moments To Remember	Columbia 1955
	No Not Much	Columbia 1956
Four Seasons	Sherry	VeeJay 1962
	Big Girls Don't Cry	VeeJay 1962
	*Rag Doll	Philips 1964
Francis, Connie	Who's Sorry Now	MGM 1958
	My Happiness	MGM 1959
	Among My Souvenirs	MGM 1959
	Mama/Teddy	MGM 1960
	Everybody's Somebody's Fool/ Jealous Of You	MGM 1960
	Together	MGM 1961
	Many Tears Ago	MGM 1961
	Where The Boys Are	MGM 1961
Franklin, Aretha	*Respect	Atlantic 1967
	*I Never Loved A Man	Atlantic 1967
	*Baby I Love You	Atlantic 1967
	*Chain Of Fools	Atlantic 1968
	*Since You've Been Gone	Atlantic 1968
	*Think	Atlantic 1968
	*I Say A Little Prayer	Atlantic 1968
	*See Saw	Atlantic 1969

Freberg, Stan	St. George And The Dragonet	Capitol 1958
Fred, John & Playboys	*Judy In Disguise	Paula 1968
Friends Of Distinction	*Grazin' In Grass	RCA 1969
Frijid Pink	House Of The Rising Son	Parrot 1970
Gentry, Bobbi	*Ode To Billie Joe	Capitol 1967
Gibbs, Georgia	Kiss Of Fire	Mercury 1952
	Tweedle Dee	Mercury 1955
	Dance With Me Henry	Mercury 1955
Gilmer, Jimmy & Fireballs	*Sugar Shack	Dot 1963
Glahe, Will	Beer Barrel Polka	Victor 1938
Gleason, Jackie	Melancholy Serenade	Capitol 1953
Godfrey, Arthur	Too Fat Polka	Columbia 1947
Goldsboro, Bobby	*Honey	United Artists 1968
Grant, Gogi	Suddenly There's A Valley	Era 1955
	Wayward Wind	Era 1956
Grass Roots	*Midnight Confessions	Dunhill 1969
Greenbaum, Norman	*Spirit In The Sky	Reprise 1970
Guess Who	*These Eyes	RCA 1969
	*Laughin'	RCA 1969
Haley, Bill	Shake, Rattle And Roll	Decca 1955
	Rock Around The Clock	Decca 1955
Hamilton IV, George	A Rose And A Baby Ruth	ABC-Par 1958
Harris, Phil	The Thing	Victor 1950
Harrison, Wilbert	Kansas City	Fury 1959
Hawkins, Edwin Singers	*Oh Happy Day	Pavillion 1969
Hayes, Bill	Davy Crockett	Cadence 1955
Haymes, Dick	You'll Never Know	Decca 1943
	Little White Lies	Decca 1948
Hebb, Bobby	*Sunny	Philips 1966
Heidt, Horace	Deep In The Heart Of Texas	Columbia 1941
Helms, Bobby	My Special Angel	Decca 1957
Herman, Woody	Laura	Columbia 1945
	Woodchopper's Ball	Decca 1947
Herman's Hermits	Mrs. Brown You've Got A Lovely Daughter	MGM 1965
	*I'm Henry VIII, I Am	MGM 1965
	*There's A Kind Of A Hush	MGM 1967
Highwaymen	Michael	United Artists 1961
Holman, Eddie	*Hey There Lonely Girl	ABC 1970
Hilltoppers	P. S. I Love You	Dot
Holly, Buddy	Peggy Sue	Coral 1958
Hollywood Argyles	Alley-Oop	Lute 1960
Hopkin, Mary	Those Were The Days	Apple 1968
Horton, Johnny	Battle Of New Orleans	Columbia 1959
Howard, Eddy	To Each His Own	Mercury 1946
Hunt, Pee Wee	12th Street Rag	Capitol 1951
	Oh	Capitol 1953
Hunter, Tab	Young Love	Dot 1957
Hyland, Brian	Itsy Bitsy Teenie Bikini	Kapp 1960
Impalas	Sorry (I Ran All The Way Home)	Cub 1959
Ink Spots	To Each His Own	Decca 1946
	The Gypsy	Decca 1946
Intruders	*Cowboys To Girls	Gamble 1968
Isley Bros.	*It's Your Thing	T. Neck 1969
Jaggerz	*The Rapper	Kama Sutra 1970
James, Harry	Ciribiribin	Columbia 1939
	One O'Clock Jump	Columbia 1941
	You Made Me Love You	Columbia 1946
James, Joni	Why Don't You Believe Me	MGM 1953
	Your Cheating Heart	MGM 1953
	Have You Heard	MGM 1954
James, Sonny	Young Love	Capitol 1957
James, Tommy & the Shondells	*Hanky Panky	Roulette 1966
Jay & Americans	*This Magic Moment	UA 1969
Jenkins, Gordon	Maybe You'll Be There	Decca 1947
with The Weavers	Goodnight Irene	Decca 1950
Jolson, Al	April Showers b/w Swanee	Decca 1945
	California Here I Come b/w Rockabye Your Baby	Decca 1946
	You Made Me Love You b/w Ma Blushin' Rose	Decca 1946
	Sonny Boy b/w My Mammy	Decca 1946
	Anniversary Song	Decca 1946
Jones, Jimmy	Handy Man	Cub 1960
	Good Timin'	Cub 1960
Jones, Spike	Cocktails For Two	Victor 1944
	All I Want For Christmas	Victor 1948
Jones, Tom	*I'll Never Fall In Love Again	Parrot 1969
	*Without Love	Parrot 1970
Jordan, Louis	Choo Cho Ch'Boogie	Decca 1946
Justis, Bill	Raunchy	Philips Int 1958
Kaempfert, Bert	Wonderland By Night	Decca 1961
Kalin Twins	When	Decca 1958
Kallen, Kitty	Little Things Mean A Lot	Decca 1954
Kim, Andy	*Baby I Love You	Steed 1969
King, Claude	Wolverton Mountain	Columbia 1962
King, Pee Wee	Slow Poke	Victor 1951
Kingston Trio	*Tom Dooley	Capitol 1958
Knight, Evelyn	A Little Bird Told Me	Decca 1948

(Con't on next Page)

# THE GUESS WHO



**RCA** Records  
and Tapes

# MILLION SELLERS

<b>Kyser, Kay</b>	Three Little Fishes	Columbia 1941
	Jingle Jangle Jingle	Columbia 1942
	Praise The Lord	Columbia 1942
	Strip Polka	Columbia 1942
	Who Wouldn't Love You	Columbia 1942
	Woody Woodpecker	Columbia 1948
<b>Laine, Frankie</b>	That's My Desire	Mercury 1947
	Shine	Mercury 1948
	Mule Train	Mercury 1949
	Lucky Ol' Sun	Mercury 1949
	Jezebel	Columbia 1951
	I Believe	Columbia 1953
	Moonlight Gambler	Columbia 1957
<b>LaRosa, Julius</b>	Eh Cumpari	Cadence 1953
<b>Lanza, Mario</b>	Be My Love	Victor 1950
	Loveliest Night of the Year	Victor 1951
<b>Lawrence, Steve</b>	Go Away Little Girl	Columbia 1963
<b>Lee, Brenda</b>	I'm Sorry/That's All You Gotta Do	Decca 1960
<b>Lee, Peggy</b>	Manana	Capitol 1948
<b>Lewis, Gary</b>	*This Diamond Ring	Liberty 1967
<b>Lemon Pipers</b>	*Green Tambourine	Buddah 1968
<b>Lewis, Jerry</b>	Rock-A-Bye Your Baby With A Dixie Melody	Decca 1956
<b>Lewis, Jerry Lee</b>	Great Balls Of Fire	Sun 1957
	Whole Lot of Shakin' Going On	Sun 1958
<b>Lindsay, Mark</b>	*Arizona	Columbia 1970
<b>Lombardo, Guy</b>	Third Man Theme	Decca 1944
<b>with Andrews Sisters</b>	Humoresque	Decca 1946
	Easter Parade	Decca 1947
	Christmas Island	Decca 1946
<b>London, Julie</b>	Cry Me A River	Liberty 1955
<b>London, Laurie</b>	*He's Got The Whole World	Capitol 1958
<b>Long, Johnny</b>	Shanty Town	Decca 1940
<b>Lovin Spoonful</b>	*Summer In The City	Kama Sutra 1966
<b>Lowe, Jim</b>	Green Door	Dot 1957
<b>Luke, Robin</b>	Susie Darlin'	Dot 1958
<b>Lund, Art</b>	Mam'selle	MGM 1947
<b>Lynn, Vera</b>	Auf Weidersehn	London 1955
<b>Lulu</b>	*To Sir With Love	Epic 1967
<b>Maddox, Johnny</b>	Crazy Otto	Dot
<b>Mamas &amp; Papas</b>	*California Dreaming	Dunhill 1966
	*Monday, Monday	Dunhill 1966
<b>Mancini, Henry</b>	*Love Theme From Romeo & Juliet	RCA 1969
<b>Mangano, Sylvana</b>	Anna	MGM 1953
<b>Materie, Ralph</b>	Caravan	Mercury 1952
	Pretend	Mercury 1953
<b>Martin, Dean</b>	That's Amore	Capitol 1953
	Memories Are Made Of This	Capitol 1955
	*Everybody Loves Somebody	Capitol 1964
<b>Martin, Freddy</b>	Piano Concerto in B Flat	Victor 1941
	White Christmas	Victor 1942
<b>Martindale, Wink</b>	Deck of Cards	Dot 1960
<b>Marvelettes</b>	Please Mr. Postman	Tamla 1960
<b>Masekela, Hugh</b>	*Grazing In The Grass	UNI 1968
<b>Mauriat, Paul</b>	*Love Is Blue	Philips 1968
<b>Mathis, Johnny</b>	Chances Are	Columbia 1957
	It's Not For Me To Say	Columbia 1957
<b>McGuire, Sisters</b>	Sincerely	Coral 1955
	Sugartime	Coral 1958
<b>McPhatter, Clyde</b>	A Lover's Question	Atlantic 1958
<b>Mercy</b>	*Love Can Make You Happy	Sundi 1969
<b>Miller, Glenn</b>	American Patrol	Victor 1939
	In The Mood	Victor 1939
	Little Brown Jug	Victor 1939
	Sunrise Serenade	Victor 1939
	Pennsylvania 6-5000	Victor 1940
	Tuxedo Junction	Victor 1940
	Chattanooga Choo Choo	Victor 1941
	Kalamazoo	Victor 1942
<b>Miller, Mitch</b>	Yellow Rose Of Texas	Columbia 1955
<b>Miller, Roger</b>	*King Of The Road	Smash 1965
<b>Mills Brothers</b>	You Always Hurt The One You Love	Decca 1944
	Paper Doll	Decca 1948
	The Glow Worm	Decca 1952
<b>Mitchell, Guy</b>	My Heart Cries For You	Columbia 1950
	Singing The Blues	Columbia 1957
<b>Modugno, Domenico</b>	Nel Blu Dipinto Di Blu (Volare)	Decca 1958
<b>Monkees</b>	*Last Train To Clarksville	Colgems 1966
	*I'm A Believer	Colgems 1966
	*A Little Bit Me, A Little Bit You	Colgems 1967
	*Pleasant Valley Sunday	Colgems 1967
	*Daydream Believer	Colgems 1967
	*Valleri	Colgems 1968

<b>Monroe, Vaughn</b>	Racing With the Moon	Victor 194
	There I've Said It Again	Victor 194
	Ballerina	Victor 194
	Riders In The Sky	Victor 194
<b>Monte, Lou</b>	Pepino	Reprise 19
<b>Mooney, Art</b>	Four Leaf Clover	MGM 1944
<b>Morgan, Russ</b>	Cruising Down The River	Decca 194
<b>Morse, Ella Mae</b>	Blacksmith Blues	Capitol 194
<b>McCoy, Clyde</b>	Sugar Blues	Decca 194
<b>Music Explosion</b>	*Little Bit Of Soul	Laurie 196
<b>Nelson, Ricky</b>	Teenager's Romance	Verve 1957
	Stood Up	Imperial 19
	Be Bop Baby	Imperial 19
	Poor Little Fool/Lonesome Town	Imperial 19
	Believe What I Say	Imperial 19
	It's Late/Never Be Anyone Else But You	Imperial 19
	Travelin' Man/Hello Mary Lou	Imperial 19
<b>New Vaudeville Band</b>	*Winchester Cathedral	Fontana 196
<b>1910 Fruitgum Co.</b>	*Simon Says	Buddah 196
	*Indian Giver	Buddah 196
<b>Nobles, Cliff &amp; Co.</b>	*Horse	Phil. LA. Of Soul 1968
<b>Ohio Express</b>	*Yummy Yummy Yummy	Buddah 196
	*1, 2, 3, Red Light	Buddah 196
	*Chewy Chewy	Buddah 196
<b>O'Kaysions</b>	*Girl Watcher	ABC 1969
<b>Oliver</b>	*Jean	Crewe 1969
<b>Orbinson, Roy</b>	Only The Lonely	Monument 19
	*Oh, Pretty Woman	Monument 19
<b>Page, Patti</b>	Tennessee Waltz	Mercury 1950
	Mockingbird Hill	Mercury 1950
	I Went To Your Wedding	Mercury 1952
	Doggie In The Window	Mercury 1952
	Changing Partners	Mercury 1953
	Cross Over the Bridge	Mercury 1954
	Allegheny Moon	Mercury 1956
<b>Patience &amp; Prudence</b>	Tonight You Belong To Me	Liberty 1956
<b>Paul &amp; Paula</b>	*Hey Paula	Philips 1960
<b>Paul, Les &amp; Mary Ford</b>	How High The Moon	Capitol 1947
	Mockin' Bird Hill	Capitol 1949
	The World Is Waiting For the Sunrise	Capitol 1949
	Vaya Con Dios	Capitol 1953
<b>Penguins</b>	Earth Angel	Dooto 1957
<b>Phillips, Phil</b>	Sea Of Love	Mercury 1959
<b>Pickett, Bobby</b>	Monster Mash	Garpax 1962
<b>Platters</b>	Only You	Mercury 1955
	The Great Pretender	Mercury 1955
	My Prayer	Mercury 1955
	Twilight Time	Mercury 1955
	Smoke Gets In Your Eyes	Mercury 1955
<b>Playmates</b>	Beep Beep	Roulette 1955
<b>Prado, Perez</b>	Cherry Pink And Apple Blossom White	Victor 1955
	*Patricia	Victor 1958
<b>Presley, Elvis</b>	Heartbreak Hotel	Victor 1956
	I Want You, I Need You, I Love You	Victor 1956
	Love Me Tender	Victor 1956
	All Shook Up	Victor 1957
	Don't Be Cruel/Hound Dog	Victor 1957
	Too Much	Victor 1957
	Teddy Bear/Loving You	Victor 1957
	Jailhouse Rock	Victor 1957
	Wear My Ring Around Your Neck	Victor 1958
	Don't	Victor 1958
	I Got Stung	Victor 1958
	*Hard Headed Woman	Victor 1958
	A Fool Such As I	Victor 1959
	Stuck On You	Victor 1959
	It's Now Or Never	Victor 1960
	Are You Lonesome Tonight	Victor 1960
	Surrender	Victor 1961
	*Can't Help Falling In Love	Victor 1961
	Good Luck Charm	Victor 1961
	Return To Sender	Victor 1961
	*In The Ghetto	RCA 1969
	*Suspicious Minds	RCA 1969
	*Don't Cry Daddy	RCA 1971
<b>Preston, Johnny</b>	Running Bear	Mercury
<b>Price, Lloyd</b>	Stagger Lee	ABC Par
	Personality	ABC Par
<b>? Question Mark &amp; the Mysterians</b>	96 Tears	Cameo 1
<b>Rascals</b>	*Groovin'	Atlantic 1
	*Beautiful Morning	Atlantic 1
	*People Got To Be Free	Atlantic 1
<b>Ray, Johnnie</b>	Cry	Columbia
<b>Rays</b>	Silhouettes	Cameo 1
<b>Redding, Otis</b>	*(Sitting On The) Dock Of The Bay	Volt 196
<b>Reeves, Jim</b>	He'll Have To Go	Victor 19



*Sincerest Thanks,  
Neil*

NEIL DIAMOND



EXCLUSIVELY ON

PERSONAL MANAGEMENT:  
**Sutton, Ltd.**  
9046 Sunset Boulevard,  
Los Angeles,  
California 90069  
(213) 278-3081

**ZRI**  
9355 Sunset Boulevard, Los Angeles, California 90049

# MILLION SELLERS

Reynolds, Debbie	Tammy	Coral 1957
Riddle, Nelson	Lisbon Antigua	Capitol 1955
Righteous Bros.	*Soul & Inspiration	Verve 1966
Riley, Jeannie C.	*Harper Valley PTA	Plantation
Rodgers, Jimmie	Honeycomb	Roulette 1957
	Kisses Sweeter Than Wine	Roulette 1958
	Secretly	Roulette 1958
	Oh-Oh I'm Falling In Love Again	Roulette 1958
Roe, Tommy	*Sheila	ABC 1969
	*Dizzy	ABC 1969
	*Sweet Pea	ABC 1969
	*Jam Up And Jelly Tight	ABC 1970
Rolling Stones	*Satisfaction	London 1965
	*Ruby Tuesday	London 1967
	*Honky Tonk Women	London 1969
Rooftop Singers	Walk Right In	Vanguard 1963
Rose, David	The Stripper	MGM 1962
Royal Guardsmen	*Snoopy Vs The Red Baron	Laurie 1967
Rydell, Bobby	Wild One/Little Bitty Girl	Cameo 1959
S Sgt. Barry Saddler	*Ballad Of The Green Berets	RCA Victor 1966
Sakamoto, Kyu	Sukiyaki	Capitol 1963
Sam & Dave	*Soul Man	Stax 1967
Sam The Sham & The Pharoahs	*Wooly Bully	MGM 1965
	*Lil' Red Riding Hood	MGM 1966
Sands, Tommy	Teen Age Crush	Capitol 1957
Santo & Johnny	Sleepwalk	Can-Am 1959
Scott, Jack	My True Love/Leroy	Carlton 1958
	What In The World's Come Over You	Top Rank 1960
Seekers	*Georgy Girl	Sekers 1967
Seville, David	Witch Doctor	Liberty 1958
	Chipmunk Song	Liberty 1958
	Alvin's Harmonica	Liberty 1959
Shannon, Del	Runaway	Bigtop 1961
Sharp, Dee Dee	Mashed Potato Time	Cameo 1962
Shaw, Artie	Begin The Beguine	Victor 1938
	Star Dust	Victor 1940
	Summit Ridge Drive	Victor 1940
Sherman, Bobby	*Little Woman	Metromedia 1969
	*Easy Come, Easy Go	Metromedia 1970
	*La La La (If I Had You)	Metromedia 1970
Shirelles	Soldier Boy	Scepter 1962
Shocking Blue	*Venus	Colossus 1970
Shore, Dinah	Buttons And Bows	Columbia 1948
Silhouettes	Get A Job	Ember 1958
Simon & Garfunkel	*Sounds Of Silence	Columbia 1966
	*Mrs. Robinson	Columbia 1968
	*Bridge Over Troubled Water	Columbia 1970
Simon, Joe	*The Chokin' Kind	Soundstage 7 1969
Sinatra, Frank	Young At Heart	Capitol 1954
Sinatra, Nancy	*These Boots Are Made For Walking	Reprise 1966
Sinatra, Nancy & Frank	*Something Stupid	Reprise 1967
Sledge, Percy	*When A Man Loves A Woman	Atlantic 1966
Sly & The Family	*Everyday People	Epic 1969
Stone	*Thank You	Epic 1970
Sonny & Cher	I Got You Babe	Atco 1965
Smith, Kate	Rose O'Day	Columbia 1941
Smith, O.C.	Little Green Apples	Columbia 1968
Stafford, Jo	Temptation	Capitol 1948
	Make Love To Me	Columbia 1954
Standley, Johnny	It's In The Book	Capitol
Starr, Kay	Wheel Of Fortune	Capitol 1952
Steppenwolf	*Born To Be Wild	Dunhill 1968
	*Magic Carpet Ride	Dunhill 1969
Stevens, Dodie	Rock And Roll Waltz	RCA Victor 1955
Stevens, Ray	*Gitarzan	Monument 1969
Stoloff, Morris	Pink Shoelaces	Crystalette 1958
	Moonglow & Picnic Theme	Decca 1956
Storm, Gale	I Hear You Knockin'	Dot
Strawberry Alarm Clock	*Incense & Peppermints	UNI 1968
Taylor, Johnnie	Who's Making Love	Stax 1968
Teddy Bears	To Know Him Is To Love Him	Dore 1958
Tex, Joe	*Skinny Legs & All	Dial 1968
Three Dog Night	One	Dunhill 1969
Thomas, B. J.	*Hooked On A Feeling	Scepter 1969
Todd, Art & Dotty	Chanson D'Amour	Era 1957
Tokens	*The Lion Sleeps Tonight	Victor 1961
Toys	*A Lover's Concerto	Dynavoice 1965
Tucker, Orrin	Oh, Johnny	Columbia 1939
Turtles	*Happy Together	White Whale 1967
Twitty, Conway	It's Only Make Believe	MGM 1958
	Lonely Blue Boy	MGM 1960
Union Gap	*Woman, Woman	Columbia 1968
	*Young Girl	Columbia 1968
	*Lady Willpower	Columbia 1968
	*Over You	Columbia 1969

Valens, Ritchie	Donna	Del-Fi 1958
Valli, Frankie	*Can't Take My Eyes Off You	Philips 1967
Vaughn, Billy	Melody Of Love	Dot 1956
	Sail Along Sil'ry Moon	Dot 1957
Vaughn, Sarah	Broken Hearted Melody	Mercury 1959
Vee, Bobby	Take Good Care Of My Baby	Liberty 1961
	*Come Back When You Grow Up	Liberty 1967
Vinton, Bobby	*Roses Are Red	Epic 1962
	*I Love How You Love Me	Epic 1969
Vogues	*Turn Around, Look At Me	Reprise 1968
Wallace, Jerry	Primrose Lane	Challenge 1960
Ward, Billy	Stardust	Liberty 1957
Waring, Fred	*Twas The Night Before Christmas	Decca 1942
Warwick, Dionne	*I Say A Little Prayer	Scepter 1968
Washington, Dinah & Benton, Brook	Baby (You Got What It Takes)	Mercury 1960
Weavers, The	On Top Of Old Smoky	Decca 1951
Weber, Joan	Let Me Go Lover	Columbia 1954
Weems, Ted	Heartaches	Decca 1950
Welk, Lawrence	*Calcutta	Dot 1961
Whiteman, Paul	Whispering	Victor 1920
	Three O'Clock In The Morning	Victor 1922
Whitfield, David	Cara Mia	London 1956
Whiting, Maggie	The Tree In The Meadow	Capitol 1948
with Jimmy Wakely	Slipping Around	Capitol 1949
Whitman, Slim	Indian Love Call	Imperial 1951
	Secret Love	Imperial 1953
	Rose Marie	Imperial 1954
Williams, Billy	I'm Gonna Sit Right Down	Corai 1957
Williams, Roger	Autumn Leaves	Kapp 1955
Williams, Tex	Smoke, Smoke, Smoke	Capitol
Willis, Chuck	What Am I Living For	Atlantic 1958
Wilson, Jackie	Night/Dogging Around	Brunswick 1960
Winterhalter, Hugo	Canadian Sunset	Victor 1956
Wooley, Sheb	Purple People Eater	MGM 1958
Youngbloods	*Get Together	RCA 1969
Young Holt Unlimited	*Soulful Strut	Brunswick 1969
Zager & Evans	*In The Year 2525	RCA 1969
Led Zeppelin	*Whole Lotta Love	Atlantic 1970
Zombies	*Time Of The Season	Date 1969

## RACK JOBBERS

(Con't from Page 114)

### TEXAS

- Allied Recorded Sound  
2704 Polk Avenue  
Houston, Texas 77003  
Ben Baker
- Handleman Company  
7432 Ardmore St.  
Houston, Texas 77201—  
Douglas Kirkness
- National Tape & Records  
5631 Old Clinton Rd.  
Houston, Texas 77020—Larry Rosmarin
- Records of Houston, Inc.  
314 East 11th St.  
Houston, Texas—Bud Daily
- Western Merchandisers of Houston  
4625 Fannin  
Houston, Texas 77004
- Lubbock News  
1001 Ave. B  
Lubbock, Texas
- Melo-D-Lane  
3422 Ave. H  
Lubbock, Texas—Paul Brink
- Recordland U.S.A.  
2612 Avenue "A"  
Bob Israel
- J's Music Land  
1209 W. Washington  
Midland, Texas
- Johnson News Agency, Inc.  
300 E. Indiana  
Midland, Texas
- Panhandle Dist. Co.  
206 S. Main St.  
Perrytown, Texas
- Weiner News Co.  
101 Menchaca  
P.O. Box 12093  
San Antonio, Texas—Stan Weiner
- Rack Supplier 519 Gibson St.  
Seagoville, Texas—Gene Ackerman

### UTAH

- ABC Record & Tape Sales Corp.  
3575 S. 700 West  
P.O. Box 15607  
South Salt Lake, Utah 84115  
Ray Peterson

Mountain West Dist.  
2195 SW Temple  
Salt Lake City, Utah

### VERMONT

- St. Johnsbury Record Dist.  
Railroad St.  
St. Johnsbury, Vermont—Loren Phelps
- Almor Co.  
Dorset St.  
South Burlington, Vermont—Ray Baron

### VIRGINIA

- Handleman Company  
6700 Fleet Drive  
Alexandria, Va. 22310—Robert Bryan
- Turner Candy Co.  
516 Rorer Ave S.W.  
Roanoke, Va.—Andy Turner

Valley Food Co.  
Paper Mill Rd.  
Box 564  
Winchester, Va.

### WASHINGTON

- ABC Record & Tape Corp.  
729 S. Fidalgo St.  
Seattle, Wash. 98108  
Stanley Jaffe; Louis Lavinthal;  
Stanley Sulman
- Craig Corporation  
540 South Front St.  
Seattle, Wash. 98108  
David Davies, James Fuscaldo
- General Record Service  
6565 7th Ave. So.  
Seattle, Washington  
Paul Potteus
- Major Distributors  
620 N.W. Bright St.  
Seattle, Wash. 98107—Bill Moore  
Robert Anderson

### WISCONSIN

- National Tape Distributors  
3515 N. 124th St.  
P.O. Box 3808  
Milwaukee, Wis. 53005—James J.  
Tiedjeus
- Record City  
Box 2359  
Milwaukee, Wis. 53212—Harold Rietz



Joe Rodan

# GOLDEN ALBUMS

## 1970

ENGELBERT—Engelbert Humperdinck—Parrot  
 ENGELBERT HUMPERDINCK—Parrot  
 CAPTURED LIVE AT THE FORUM—3 Dog Night—Dunhill  
 EASY RIDER—Original Soundtrack—ABC  
 THE BEST OF CHARLEY PRIDE—RCA  
 VOLUNTEERS—Jefferson Airplane—RCA  
 CROWN OF CREATION—Jefferson Airplane—RCA  
 FROM ELVIS IN MEMPHIS—Elvis Presley—RCA  
 HELLO I'M JOHNNY CASH—Columbia  
 SEE WHAT TOMORROW BRINGS—Peter Paul & Mary—Warner Bros.  
 ALIVE ALIVE-O—Jose Feliciano—RCA  
 BRIDGE OVER TROUBLED WATER—Simon & Garfunkel—Columbia  
 BOBBY SHERMAN—Metromedia  
 MANTOVANI'S GOLDEN HITS—London  
 GET TOGETHER—Andy Williams—Columbia  
 MORRISON HOTEL—The Doors—Elektra  
 GOIN' OUT OF MY HEAD—Lettermen—Capitol  
 HEY JUDE—Beatles—Apple  
 MY WAY—Frank Sinatra—Reprise  
 LIVE PEACE IN TORONTO 1969—Plastic Ono Band—Apple  
 MONSTER—Steppenwolf—Dunhill  
 FELICIANO 10 TO 23—Jose Feliciano—RCA  
 DEJA VU—Crosby, Stills, Nash & Young—Atlantic  
 UP-UP AND AWAY—5th Dimension—Soul City  
 WARM—Herb Alpert—A & M  
 CHICAGO—Columbia  
 TAMMY'S GREATEST HITS—Tammy Wynette—Epic  
 CLAUDINE—Claudine Longet—A&M  
 JOE COCKER—A&M  
 TOM—Tom Jones—Parrot  
 A SONG WILL RISE—Peter, Paul & Mary—Warner Bros.  
 McCARTNEY—Paul McCartney—Apple  
 A GIFT FROM A FLOWER TO A GARDEN—Donovan—Epic  
 DON'T COME HOME A DRINKIN' (WITH LOVIN' ON YOUR MIND)—Loretta Lynn—Decca  
 MIDNIGHT COWBOY — Soundtrack — United Artists  
 MUSIC FROM BUTCH CASSIDY AND THE SUNDANCE KID — Burt Bacharach — A&M  
 LET IT BE — Beatles — Apple  
 VENTURES PLAY TELSTAR — Dolton  
 GOLDEN GREATS — Ventures — Dolton

## 1969

ARETHA NOW—Aretha Franklin—Atlantic  
 IN—A—GADDA—DA—VIDA—Iron Butterfly—Atco  
 FRESH CREAM—Atco  
 TIME HAS COME—Chambers Bros.—Columbia  
 JUNGLE BOOK—Soundtrack—Disneyland  
 BEATLES—Apple  
 HERB ALPERT'S CHRISTMAS ALBUM—A & M  
 HARPER VALLEY P.T.A.—Jeannie C. Riley—Plantation  
 FUNNY GIRL—Soundtrack—Columbia  
 BEGGERS BANQUET—Rolling Stones—London  
 THE SEA—San Sabastian Strings—Warner Bros.  
 THE STORY OF MARY POPPINS—Disneyland  
 HEY LITTLE ONE—Glen Campbell—Capitol  
 THE CHRISTMAS SONG—Nat King Cole—Capitol  
 THE LETTERMAN . . . AND LIVE—Capitol  
 WILDFLOWERS—Judy Collins—Elektra  
 ALBUM 1700—Peter, Paul & Mary—Warner Bros.  
 GENTRY & CAMPBELL—Bobbie Gentry — Glen Campbell—Capitol  
 DEAN MARTIN'S GREATEST HITS VOL. 1—Reprise  
 YELLOW SUBMARINE—Soundtrack—Apple  
 STEPPENWOLF THE SECOND—Dunhill  
 WHO WILL ANSWER—Ed Ames—RCA  
 BOOTS WITH STRINGS—Boots Randolph—Monument  
 DIONNE WARWICK'S GREATEST HITS PART 1—Scepter  
 A MAN WITHOUT LOVE—Engelbert Humperdinck—Parrot  
 THE LAST WALTZ—Engelbert Humperdinck—Parrot  
 THE ASSOCIATION'S GREATEST HITS—Warner Bros./7 Arts  
 WEDNESDAY MORNING 3:AM—Simon & Garfunkel—Columbia  
 WONDERLAND BY NIGHT—Bert Kaempfert—Decca  
 BERT KAEMPFERT'S GREATEST HITS—Decca  
 200 M.P.H.—Bill Cosby—Warner Bros./7 Arts  
 HAIR—Original Cast—RCA  
 IT MUST BE HIM—Ray Conniff—Columbia  
 YOUNG GIRL—Gary Puckett & Union Gap—Columbia  
 HIS HAND IN MINE—Elvis Presley—RCA  
 BLOOD, SWEAT & TEARS—Columbia  
 GALVESTON—Glen Campbell—Capitol

(Con't on next Column)

## 1969 (Con't)

FREEDOM SUITE—Rascals—Atlantic  
 GOODBYE—Cream—Atco  
 DONOVAN'S GREATEST HITS—Epic  
 2001 A SPACE ODYSSEY—Original Soundtrack—MGM  
 SOULIN—Lou Rawls—Capitol  
 BEST OF THE LETTERMEN—Capitol  
 NASHVILLE SKYLINE—Bob Dylan—Columbia  
 FEVER ZONE—Tom Jones—Parrot  
 HELP YOURSELF—Tom Jones—Parrot  
 EQUINOX—Sergio Mendes & Brasil 66—A&M  
 A DAY IN THE LIFE—Wes Montgomery—A&M  
 FOOL ON THE HILL—Sergio Mendes & Brasil  
 66—A&M

## 1968

WE WISH YOU A MERRY CHRISTMAS—Ray Conniff—Columbia CL 1892/CS 8692  
 HERB ALPERT'S NINTH—A&M 134/SP 4134  
 MAGICAL MYSTERY TOUR—Beatles—Capitol MAL/SMAL 2835  
 BUTTONED DOWN MIND STRIKES BACK—Bob Newhart—Warner Bros. W/WS 1393  
 INSIGHT OUT—Association—Warner Bros. W/WS 1696  
 BOB DYLAN'S GREATEST HITS—Columbia KCL 2663/KCS 9463  
 LOVE ME WITH ALL YOUR HEART—Jim Nabors—Columbia CL 2558/9358  
 STRANGE DAYS—Doors—Elektra EKS 74014  
 DREAM WITH DEAN—Dean Martin—Reprise R/RS 6123  
 GUANTANAMERA—Sandpipers—A&M 117/SP 4117  
 FAREWELL TO THE FIRST GOLDEN ERA—Mamas & Papas—Dunhill D/DS 50025  
 HOW GREAT THOU ART—Elvis Presley—RCA Victor LPM/LSP 3758  
 DISTANT DRUMS—Jim Reeves—RCA Victor LPM/LSP 3542  
 BLOOMING HITS—Paul Mauriat—Philips PHM 200-248/PHS 600-248  
 DR. DOOLITTLE—Soundtrack—20th Century Fox DTCS 5101  
 BEST OF BUCK OWENS—Capitol T/ST 2105  
 BYRDS GREATEST HITS—Columbia CL 2716/CS 9561  
 THE GRADUATE—Soundtrack—Columbia OS 3180  
 JOHN WESLEY HARDING—Bob Dylan—Columbia CL 2804/CS 9604  
 WELCOME TO MY WORLD—Dean Martin—Reprise R/RS 6258  
 HOUSTON—Dean Martin—Reprise R/RS 6181  
 ARE YOU EXPERIENCED—Jim Hendrix—Reprise RS 6261  
 MODERN SOUNDS IN COUNTRY AND WESTERN MUSIC VOL. 2—Ray Charles—ABC/ABCS 435  
 RAY CHARLES GREATEST HITS—ABC/ABCS 415  
 LOVING YOU—Elvis Presley—RCA Victor LPM/LSP 1515  
 TURTLE'S GOLDEN HITS—White Whale WW 115/WWS 7115  
 THE BIRDS, THE BEES AND THE MONKEES—Colgems COS 109  
 GIGI—Soundtrack—MGM E/SE 3641 ST  
 BOOKENDS—Simon & Garfunkel KCS 9529  
 LOVE ANDY—Andy Williams—Columbia  
 DORIS DAY'S GREATEST HITS—Columbia  
 DISRAEL, GEARS—Cream—ATCO  
 MERRY CHRISTMAS—Andy Williams—Columbia  
 BEAT OF THE BRASS—Herb Alpert & Tijuana Brass—A&M  
 WHEELS OF FIRE—Cream—ATCO  
 VANILLA FUDGE—ATCO  
 TO RUSSELL, MY BROTHER WHOM I SLEPT WITH—Bill Cosby—Warner Bros.  
 SOMEWHERE MY LOVE—Roger Williams—Kapp  
 GLENN MILLER—RCA  
 WAITING FOR THE SUN DOORS—Elektra  
 THE GOOD, THE BAD AND THE UGLY—Soundtrack U. A.  
 A MAN AND HIS SOUL—Ray Charles—ABC  
 LADY SOUL—Aretha Franklin—Atlantic  
 LOOK AROUND—Sergio Mendes & Brasil '66 A&M  
 THE YOUNG RASCALS—Atlantic  
 THE RASCAL'S GREATEST HITS/Time peace—Atlantic  
 CAMELOT—Soundtrack—W.B.  
 FELICIANO—Jose Feliciano—RCA  
 AXIS: BOLD AS LOVE—Jimi Hendrix Experience—Reprise  
 CHEAP THRILLS—Big Brother Holding Co.—Columbia  
 MY LOVE FORGIVE ME—Robert Goulet—Columbia  
 JOHNNY CASH AT FOLSOM PRISON—Columbia  
 HONEY—Andy Williams—Columbia  
 HONEY—Bobby Goldsboro—United Artists  
 WICHITA LINEMAN—Glen Campbell—Capitol  
 STEPPENWOLF—Dunhill  
 ELECTRIC LADYLAND—Jimi Hendrix Experience—Reprise  
 KINK'S GREATEST HITS—Reprise  
 DEAN MARTIN'S CHRISTMAS ALBUM—Reprise  
 PURPLE ONION—Smothers Bros.—Mercury  
 THE RIGHTEOUS BROS. GREATEST HITS—Verve  
 THIS IS TOM JONES—Parrot  
 HANK WILLIAM'S GREATEST HITS—MGM  
 THE VERY BEST OF CONNIE FRANCIS—MGM  
 THE BEST OF HERMAN'S HERMITS VOL. 11—MGM  
 HOW THE WEST WAS WON—Orig. Soundtrack—MGM  
 YOUR CHEATIN' HEART—Hank Williams—MGM  
 THE STRIPPER AND OTHER FUN SONGS FOR THE FAMILY  
 —David Rose & Orchestra—MGM  
 THERE'S A KIND OF HUSH ALL OVER THE WORLD—  
 Herman's Hermits—MGM  
 ROMEO & JULIET — Orig. Soundtrack—Capitol  
 TOM JONES LIVE—Parrot  
 THE AGE OF AQUARIUS—Fifth Dimension—Soul City  
 ELVIS T.V. SPECIAL—Elvis Presley—RCA

(Con't on next Page)

# OUR GAL DIANA

The story which asks the question: Can a little girl from Detroit's inner city find happiness and success as the new Super Star of the 70's? Yes.

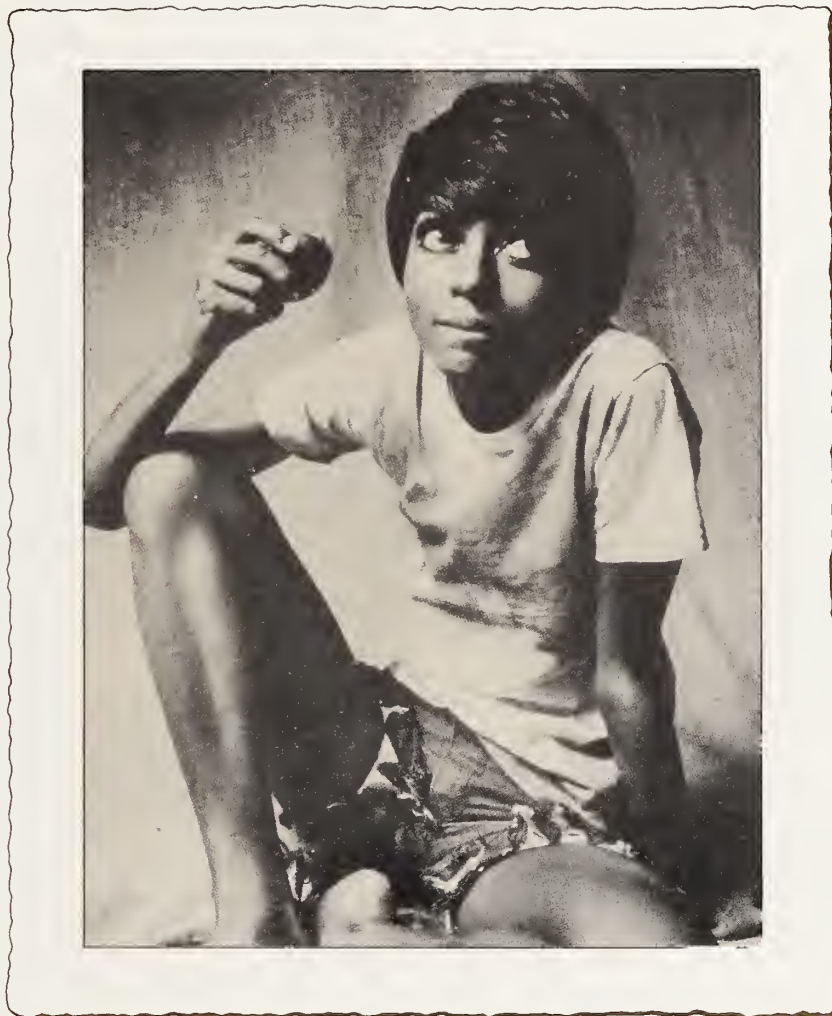

*Thanks  
Diana Ross*



# GOLDEN ALBUMS

## 1968 Con't.

BALL—Iron Butterfly—Atco  
 LED ZEPPELIN—Atlantic  
 JOHNNY CASH'S GREATEST HITS—Columbia  
 OLIVER—Orig. Soundtrack—Colgems  
 THE SOFT PARADE—Doors—Elektra  
 JOHNNY CASH AT SAN QUENTIN—Columbia  
 SWITCHED ON BACH—Walter Carlos/Benjamin Folkman—Columbia  
 THREE DOG NIGHT—Dunhill  
 BLIND FAITH—Atco  
 HAPPY HEART—Andy Williams—Columbia  
 GENTLE ON MY MIND—Dean Martin—Reprise  
 ABBEY ROAD—Beatles—Apple  
 LIVE IN LAS VEGAS—Tom Jones—Parrot  
 BEST OF THE BEE GEES—Atco  
 BEST OF THE CREAM—Atco  
 LED ZEPPELIN II—Atlantic  
 GREEN GRASS OF HOME—Tom Jones—Parrot  
 LET IT BLEED—Rolling Stones—London  
 THE BAND—Capitol  
 WHO KNOWS WHERE THE TIME GOES—Judy Collins—Elektra  
 SMASH HITS—Jimi Hendrix Experience—Reprise  
 GOLDEN INSTRUMENTALS—Billy Vaughn—Dot

## 1967

I NEVER LOVED A MAN—Aretha Franklin—Atlantic 8139/SD 8139  
 SGT. PEPPER'S LONELY HEARTS CLUB BAND—Beatles—Capitol T/ST 2653  
 JUST LIKE US—Paul Revere & The Raiders—Columbia CL 2451/CS 9251  
 MORE OF THE MONKEES—Colgems—COM/COS 102  
 S.R.O.—Herb Alpert & The Tijuana Brass—A&M LP 119/SP 4119  
 GOT LIVE IF YOU WANT IT—Rolling Stones—London LL 3493/PS 493  
 TILL—Roger Williams—Kapp KL/KS 1081  
 SONGS OF THE FABULOUS FIFTIES, PART 1—Kapp KL 1209/KS 3209  
 SONGS OF THE FABULOUS FIFTIES, PART 2—Kapp KL 1210/KS 3210  
 ROGERS WILLIAMS GREATEST HITS—Kapp KL 1260/3260  
 YAKETY SAX—Boots Randolph—Monument  
 THAT'S LIFE—Frank Sinatra—Reprise F/FS 1020  
 LOU RAWLS LIVE—Capitol T/TS 2459  
 THE TWO SIDES OF THE SMOTHERS BROS.—Mercury MG 20675/SR 60675  
 BETWEEN THE BUTTONS—Rolling Stones—London LL 3499/PS 499  
 MIDNIGHT RIDE—Paul Revere & The Raiders—Columbia CL 2508/CS 9308  
 THOROUGHLY MODERN MILLIE—Original Soundtrack—Decca DL 1500/71500  
 THE BEST OF MANCINI—Henry Mancini—RCA Victor LPM/LSP 2693  
 AN EVENING WITH BELAFONTE—Harry Belafonte—RCA Victor LPM/LSP 3415  
 BEST OF THE BEACH BOYS—Capitol T/DT 2545  
 WINCHESTER CATHEDRAL—Lawrence Welk—Dot DLP 3774/DLP 25774  
 SPIRIT OF '67—Paul Revere & The Raiders—Columbia CL 2595/CS 9395  
 MAMAS & PAPAS DELIVER—Dunhill D/S 50014  
 BORN FREE—Roger Williams—Kapp KL 1501/KS 3501  
 MAME—Original Cast—Columbia KOL 6600/KOS 3000  
 HEADQUARTERS—Monkees—Colgems COM/COS 103  
 MY CUP RUNNETH OVER—Ed Ames—RCA Victor LPM/LPS 3774  
 STRANGERS ON THE SHORE—Mr. Åcker Bilk—Atco  
 REVENGE—Bill Cosby—Warner Bros. W/WS 1691  
 PARSLEY, SAGE, ROSEMARY & THYME—Simon & Garfunkel—Columbia CL 2463/CS 9363  
 BORN FREE—Andy Williams—Columbia CL 2680/CS 9480  
 THE BEST OF THE LOVIN' SPOONFUL—Kama Sutra KLP/KLPS 8056  
 THEMES FOR YOUNG LOVERS—Percy Faith & Orch.—Columbia CL 2704/CS 9504  
 I WALK THE LINE—Johnny Cash—Columbia CL 2190/CS 8990  
 SURREALISTIC PILLOW—Jefferson Airplane—RCA Victor LPM/LSP 3766  
 FLOWERS—Rolling Stones—London LL 3509/PS 509  
 A MAN AND A WOMAN—Soundtrack—United Artists UAL 4147/UAS 5174  
 EBB TIDE—Earl Grant—Decca DL/DL 7 4165  
 BLUE MIDNIGHT—Bert Kaempfert—Decca DL/DL 7 4569  
 SOUNDS LIKE—Herb Alpert & Tijuana Brass—A&M LP 124/SP 4124  
 SERGIO MENDES & BRASIL '66—A&M LP 116/SP 4116  
 SOUNDS OF SILENCE—Simon & Garfunkel—Columbia CL 2469/CS 9269  
 PAUL REVERE & THE RAIDERS GREATEST HITS—Columbia KCL 2662/KCS 9462  
 BLONDE ON BLONDE—Bob Dylan—Columbia C2L 41/C2S 841  
 HIGHWAY 61—Bob Dylan—Columbia CL 2389/CS 9189  
 BRINGING IT ALL BACK HOME—Bob Dylan—Columbia CL 2328/CS 9128  
 THE DOORS—Elektra EK 4007/EKS 74007  
 2ND VAULT OF GOLDEN HITS—Four Seasons—PHILIPS PHM 200-221/PHS 600-221  
 ODE TO BILLIE JOE—Bobbie Gentry—Capitol T/ST 2830  
 TONY BENNETT'S GREATEST HITS VOLUME III—Columbia CL 2373/CS 9173  
 PISCES, AQUARIUS, CAPRICORN AND JONES LTD.—Monkees—Colgems COM/COS 104  
 SINATRA AT THE SANDS—Frank Sinatra—Reprise 2F/2FS 1019  
 THEN ALONG CAME THE ASSOCIATION—Warner Bros. 1702  
 THEIR SATANIC MAJESTY'S REQUEST—Rolling Stones—London NP/NPS 2  
 RELEASE ME—Engelbert Humperdinck—Parrot PA 61012/PAS 71012

## 1966

SUMMER DAYS—Beach Boys—Capitol T/ST-2354  
 GOLDEN HITS—Roger Miller—Smash 27073/67073  
 BALLADS OF THE GREEN BERETS—S/Sgt Barry Sadler—RCA Victor LPM-3547/LSP-3547  
 ROY ORBISON'S GREATEST HITS—Monument—8000/18000  
 LIVING LANGUAGE SPANISH—Young People's—  
 LIVING LANGUAGE FRENCH—Young People's—  
 COLOR ME BARBRA—Barbra Streisand—Columbia CL-2478/CS-9278  
 I'M THE ONE WHO LOVES YOU—Dean Martin—Reprise—6170/S-6170  
 BIG HITS (HIGH TIDE & GREEN GRASS)—The Rolling Stones—London LP-1  
 OLIVER—Original Cast—RCA Victor LOCD/LSOD-2004  
 SOUTH OF THE BORDER—Herb Alpert's Tijuana Brass—A&M LP/SP-108  
 THE LONELY BULL—Herb Alpert's Tijuana Brass—A&M LP/SP-101  
 WHAT NOW MY LOVE—Herb Alpert's Tijuana Brass—A&M LP-114/SP-4114  
 HERB ALPERT'S TIJUANA BRASS, VOL. 2—A&M LP/SP-103  
 MY WORLD—Eddy Arnold—RCA Victor LPM/LSP-3466  
 SOUTH PACIFIC—Original Cast—Columbia OL-4180/OS-2040  
 IF YOU CAN BELIEVE YOUR EYES AND EARS—Mamas & Papas—Dunhill D/DS 50006  
 YESTERDAY & TODAY—Beatles—Capitol T/ST 2553  
 THE BEST OF JIM REEVES—RCA Victor LPM/LSP 2890  
 THE BEST OF THE ANIMALS—MGM E/SE 4324  
 DANG ME—Roger Miller—Smash MPS 27049/FRS 67049  
 GOLD VAULT OF HITS—Four Seasons—Philips PHM 200-196/PHS 600-196  
 AFTERMATH—Rolling Stones—London LL 3476/PS 4776  
 DR. ZHIVAGO—Soundtrack—MGM E/SE 6 ST  
 THINK ETHNIC—Smothers Bros.—Mercury MG 20777/SR 60777  
 STRANGERS IN THE NIGHT—Frank Sinatra—Reprise F/FS 1017  
 REVOLVER—Beatles—Capitol T/TS 2576  
 THE DAVE CLARK FIVE'S GREATEST HITS—Epic LN 24185/BN 26185  
 SOMEWHERE MY LOVE—Ray Conniff Singers—Columbia CL 2519/CS 9319  
 THE SHADOW OF YOUR SMILE—Andy Williams—Columbia CL 2499/CS 9299  
 THE BEST OF AL HIRT—RCA Victor LPM/LSP 3309  
 I STARTED OUT AS A CHILD—Bill Cosby—Warner Bros. W/WS 1567  
 WONDERFULNESS—Bill Cosby—Warner Bros. W/WS 1634  
 WHY IS THERE AIR—Bill Cosby—Warner Bros. W/WS 1606  
 BILL COSBY IS A VERY FUNNY FELLOW, RIGHT!—Warner Bros. W/WS 1518  
 JEANETTE MAC DONALD & NELSON EDDY FAVORITES—RCA Victor LPM/LSP 1738  
 PERRY COMO SINGS MERRY CHRISTMAS MUSIC—Camden CAL/CAS 600  
 THE MONKEES—Colgems COM/SOC 101  
 ELVIS PRESLEY—RCA Victor LPM/LSP 1254  
 ELVIS' GOLD RECORDS, VOL. 2—RCA Victor—LPM/LSP 2075  
 ELVIS' GOLD RECORDS, VOL. 3—RCA Victor—LPM/LSP 2765  
 JOAN BAEZ, VOL. 2—Vanguard—VRS 9094/VSD 2097  
 JOAN BAEZ—Vanguard—VRS 9078/USD 2077  
 JOAN BAEZ IN CONCERT—Vanguard—VRS 9112/VSD 2122  
 SOUL AND INSPIRATION—Righteous Brothers—Verve V/V-6 5001  
 MAMAS AND PAPAS—Dunhill D/S 50010  
 THE MONKEES—Colgems—Com/Cos 101  
 MY NAME IS BARBRA, TWO—Barbra Streisand—Columbia CL-2409/CS-9209  
 THE BEST OF HERMAN'S HERMITS—MGM 4315/4315  
 DECEMBER'S CHILDREN—The Rolling Stones—London 3451/451  
 SEPTEMBER OF MY YEARS—Frank Sinatra—Reprise 1014/S-1016  
 A MAN & HIS MUSIC—Frank Sinatra—Reprise 1016/S-1016  
**1965**  
 GLAD ALL OVER—Dave Clark Five—Epic LN-24093/BN-26093  
 PETER, PAUL & MARY IN CONCERT—Warner Bros. 1555/S-1555  
 EVERYBODY LOVES SOMEBODY—Dean Martin—Reprise R-6130/RS-6130  
 WONDERLAND OF GOLDEN HITS—Andre Kostelanetz—Columbia CL-2039/CS-8839  
 BARBRA STREISAND/THE THIRD ALBUM—Columbia CL-2154/CS-8954  
 RING OF FIRE—Johnny Cash—Columbia CL-2053/CS-8853  
 BEACH BOYS IN CONCERT—Capitol TAO-2198/STAO-2198  
 ALL SUMMER LONG—Beach Boys—Capitol T-2110/ST-2110  
 SUGAR LIPS—Al Hirt—RCA Victor LPM-2965/LPS-2965  
 PEOPLE—Barbra Streisand—Columbia CL-2215/CS-9015  
 THE SOUND OF MUSIC—Soundtrack—RCA Victor LOCD-2005/LSOD-2005  
 TRINI LOPEZ AT P.J.'S—Reprise R-6093/RS-6093  
 GETZ/GILBERTO—Stan Getz—MGM/Verve 8545/68545  
 BEATLES VI—Capitol T-2358/ST-2358  
 DEAR HEART—Andy Williams—Columbia CL 2338/CS 9138  
 HELP!—The Beatles—Capitol MAS-2386/SMHS-2386  
 INTRODUCING HERMAN'S HERMITS—MGM 4282/S-4282  
 HERMAN'S HERMITS ON TOUR—MGM 4295/S-4295  
 MORE ENCORE OF GOLDEN HITS—The Platters—Mercury 20591/60252  
 RETURN OF ROGER MILLER—Smash 27061/67061  
 GREAT SONGS FROM MY FAIR LADY—Andy Williams—Columbia CL-2205/CS-9005  
 GUNFIRE BALLADS & TRAIL SONGS—Marty Robbins—Columbia CL-1349/CS-8158  
 LOOK AT US—Sonny & Cher—Atco 177  
 THE BEACH BOYS TODAY—Capitol T-2269/ST-2269  
 THE PINK PANTHER—Henry Mancini—RCA Victor LPM-2795/LSP-2795  
 OUT OF OUR HEADS—The Rolling Stones—London 3429/429  
 FIDDLER ON THE ROOF—Original Cast—RCA Victor LOC-1093/LSO-1093  
 SURFER GIRL—The Beach Boys—Capitol 1981/ST-1981  
 SURFIN' USA—The Beach Boys—Capitol T-1890/ST-1890  
 SINATRA'S SINATRA—Frank Sinatra—Reprise 1010/9-1010  
 WELCOME TO THE LBJ RANCH—Capitol W-2423/WS-2423  
 MY NAME IS BARBRA—Barbra Streisand—Columbia CL-2336/CS-9136  
 THE DOOR IS STILL OPEN TO MY HEART—Dean Martin—Reprise 6140/S-6140  
 GOING PLACES—Herb Alpert's Tijuana Brass—A&M LP-112/SP-4112  
 WHIPPED CREAM AND OTHER DELIGHTS—Herb Alpert's Tijuana Brass—A&M LP/SP-110  
 RUBBER SOUL—The Beatles—Capitol T-2442/ST-2442

(Con't. on next page)



# paul anka

bookings **GMA**

**RCM**

spanka music  
200 west 57 street  
suite 1510  
new york, n. y. 10017  
(212) 582-5463

# GOLDEN ALBUMS

## 1964

MY FAIR LADY—Original Cast—Columbia OL 5090/OS 2015  
JOHN FITZGERALD KENNEDY—A MEMORIAL ALBUM—Premier CFX 402099  
CAROUSEL—Film Soundtrack—Capitol—W 694/SW 694  
THE KING AND I—Film Soundtrack—Capitol—W 74/SW 740  
RAMBLIN' ROSE—Nat "King" Cole—Capitol T 1793/ST 1793  
MEET THE BEATLES—The Beatles—Capitol T-2047/ST-2047  
HONEY IN THE HORN—Al Hirt—RCA Victor LPM 2733/LSO 2733  
THE BEATLES' SECOND ALBUM—The Beatles—Capitol T 2080/ST 2080  
THE SECOND BARBRA STREISAND ALBUM—Barbra Streisand—Columbia CL 2045/CS 8854  
HELLO, DOLLY!—Original Cast—RCA Victor LCO 1087/LSO 1087  
HELLO, DOLLY!—Louis Armstrong—Kapp 1364/3364  
THE WONDERFUL WORLD OF ANDY WILLIAMS—Columbia CL-2137/CS-8937  
CHRISTMAS HYMNS & CAROLS—Robert Shaw—RCA Victor LM-2139/LSC-2139  
VICTORY AT SEA, Vol. 1—Robert Russell Bennett—RCA Victor LM-2335/LSC-2335  
SOMETHING NEW—The Beatles—Capitol T-2108/ST-2108  
THE BEST OF THE KINGSTON TRIO—Capitol T-1705, 2280/ST-1705, 2280  
UNFORGETTABLE—Nat King Cole—Capitol T-357/DT-357  
RAMBLIN'—New Christy Minstrels—Columbia CL-2055/CS-8855  
THE BARBRA STREISAND ALBUM—Columbia CL-2007/CS-8807  
FUNNY GIRL—Original Cast—Capitol VAS-2059/SVAS-2059  
JOHNNY HORTON'S GREATEST HITS—Columbia CL-1596/CS-8396  
COTTON CANDY—Al Hirt—RCA Victor LPM-2917/LSP-2917  
THE ANDY WILLIAMS CHRISTMAS ALBUM—Columbia CL-2087/CS-8887  
CALL ME IRRESPONSIBLE—Andy Williams—Columbia CL-2171/CS-8971  
MY FAIR LADY—Soundtrack—Columbia KOL-8000/KOS-2600  
BEATLES '65—Capitol T-2228/ST-2228  
THE BEATLES STORY—Capitol TBO-2222/STBO-2222  
MARY POPPINS—Soundtrack—Vista 4026/S-4026

## 1963

WEST SIDE STORY—Original Soundtrack—Columbia OL-5670/OS-2070  
GLORIOUS SOUND OF CHRISTMAS—Eugene Ormandy—Philadelphia Orchestra—Columbia ML-5769/MS-6369  
1812 OVERTURE-TCHAIKOVSKY—Antal Dorati and The Minneapolis Symphony—Mercury MG-50054/SR-90054  
EXODUS—Original Soundtrack—RCA Victor LOL-1058/LSO-1058  
CALYPSO—Harry Belafonte—RCA Victor LPM-1248/LSP-1248  
G. I. BLUES—Elvis Presley—RCA Victor LPM-2256/LSP-2256  
SEASON'S GREETINGS FROM PERRY COMO—Perry Como—RCA Victor LPM-2066/LSP-2066  
VIVA—Percy Faith—Columbia CL-1075/CS-8038  
THE MUSIC MAN—Soundtrack—Warner Bros. B-1459/BS-1459  
TIME OUT—Dave Brubeck Quartet—Columbia CL-1397/CS-8192  
I LEFT MY HEART IN SAN FRANCISCO—Tony Bennett—Columbia CL-1869/CS-8669  
ELVIS' CHRISTMAS ALBUM—Elvis Presley—RCA Victor LOC-1035/LPH-1951  
GIRLS, GIRLS, GIRLS—Elvis Presley—RCA Victor LPM-2621/LSP-2621  
BELAFONTE RETURNS TO CARNEGIE HALL—Harry Belafonte—RCA Victor LOC-6007/LSO-6007  
BELAFONTE—Harry Belafonte—RCA Victor LPM-1150  
JUMP-UP-CALYPSO—Harry Belafonte—RCA Victor LPM-2388/LSP-2388  
MOVIN'—Peter, Paul & Mary—Warner W/WS 1473  
EXODUS—Mantovani—London IL-323<sup>3</sup>/PS-224  
DAYS OF WINE AND ROSES—Andy Williams—Columbia CL-2015/CS-8815  
MOON RIVER & OTHER GREAT MOVIE THEMES—Andy Williams—Columbia CL 1809/CS 8609  
HANDEL'S MESSIAH—Eugene Ormandy & Philadelphia Orch.—Columbia M2L 263/M2S 607  
CHRISTMAS WITH CONNIFF—Ray Conniff—Columbia CL 1390/CS 8185  
THE LORD'S PRAYER—Mormon Tabernacle Choir—Columbia ML 5386/MS 6068  
PORGY AND BESS—Original Sound Track—Columbia OL 5410/OS 2016  
FOLK SONG SING ALONG—Mitch Miller—Columbia CL 1316/CS 8118  
IN THE WIND—Peter, Paul & Mary—Warner Bros. WB 1507/WS 1507  
SINGING NUN—Soeur Sourire—Philips PCC 203/PCC 603

## 1962

PARTY SING ALONG WITH MITCH—Mitch Miller—Columbia CL-1331/LS-8138  
MORE JOHNNY'S GREATEST HITS—Johnny Mathis—Columbia CL-1344/LS-8150  
WEST SIDE STORY—Original Cast—Columbia OL-5230/OS-2001  
CAMELOT—Original Cast—Columbia KOL-5620/KOS-2031  
FLOWER DRUM SONG—Original Cast—Columbia—OL-5350/OS-2009  
THEME FROM A SUMMER PLACE—Billy Vaughn—Dot 3276/25276  
BLUE HAWAII—Billy Vaughn—Dot 3165/25165  
SAIL ALONG SILVERY MOON—Billy Vaughn—Dot 3100/25100  
BOB NEWHART BUTTON DOWN MIND—Bob Newhart—Warner Bros. W-1379/WS-1379  
SATURDAY NIGHT SING ALONG WITH MITCH—Mitch Miller—Columbia CL-1414/CS-8211  
MEMORIES SING ALONG WITH MITCH—Mitch Miller—Columbia CL-1542/LS-8342  
SENTIMENTAL SING ALONG WITH MITCH—Mitch Miller—Columbia CL-1457/LS-8251  
STAR CAROL—Ernie Ford—Capitol T-1071/ST-1071  
NEARER THE CROSS—Ernie Ford—Capitol T-1005/ST-1005  
FRANK SINATRA SINGS FOR ONLY THE LONELY—Frank Sinatra—Capitol W-1053  
NICE 'N' EASY—Frank Sinatra—Capitol W-1417

## 1962 Con't.

SONGS FOR SWINGIN' LOVERS—Frank Sinatra—Capitol W-653  
STRING ALONG—Kingston Trio—Capitol T-1407  
MUSIC, MARTINIS AND MEMORIES—Jackie Gleason—Capitol W-509  
MUSIC FOR LOVERS ONLY—Jackie Gleason—Capitol W-352  
JUDY AT CARNEGIE HALL—Judy Garland—Capitol WBO-1568  
HAPPY TIMES SING ALONG—Mitch Miller—Columbia CL-1568/CS-8368  
MEMORIES ARE MADE OF THIS—Ray Conniff—Columbia CL-1574/CS-8374  
CONCERT IN RHYTHM—Ray Conniff—Columbia CL-1720/CS-8520  
FAITHFULLY—Johnny Mathis—Columbia CL-1422/CS-8219  
SWING SOFTLY—Johnny Mathis—Columbia CL-1165/CS-8023  
OPEN FIRE, TWO GUITARS—Johnny Mathis—Columbia CL-1270/CS-8056  
PETER, PAUL AND MARY—Peter, Paul and Mary—Warner Bros. W-1449/WS-1449  
MY SON THE FOLK SINGER—Allan Sherman—Warner Bros. W-1475/WS-1475  
THE FIRST FAMILY—Vaughn Meader—Cadence CLP-3060

## 1961

CALCUTTA—Lawrence Welk—Dot DLP-3359/ST-25359  
COME DANCE WITH ME—Frank Sinatra—Capitol W-1069/WS-1069  
SOLD OUT—Kingston Trio—Capitol T-1352/ST-6352  
GLENN MILLER STORY—Glenn Miller Orchestra—RCA Victor LPM-1192  
CHRISTMAS CAROLS—Mantovani—London LL-913/PS-142  
THEATRE LAND—Mantovani—London LL-1219/PS-125  
FILM ENCORES VOL. 1—Mantovani—London LL-1700/PS-124  
GEMS FOREVER—Mantovani—London LL-3032/PS-106  
STRAUSS WALTZES—Mantovani—London LL-685/PS-118  
SPIRITUALS—Ernie Ford—Capitol T-818  
ELVIS' GOLDEN RECORDS—Elvis Presley—RCA Victor LPM-1707  
BELAFONTE AT CARNEGIE HALL—Harry Belafonte—RCA Victor LOC-6006/LSO-6006  
TCHAIKOVSKY CONCERTO—Van Cliburn—RCA Victor LM-2252/LSC-2252  
ENCORE-GOLDEN HITS—The Platters—Mercury MG-20472/SR-60243  
BLUE HAWAII—Elvis Presley—RCA Victor LPM-2426/LSP-2426  
HOLIDAY SING ALONG WITH MITCH—Mitch Miller—Columbia CL-1701/LS-8501

## 1960

STUDENT PRINCE—Mario Lanza—RCA Victor LM-1837  
60 YEARS OF MUSIC—Honoring 30 Great Artists—RCA Victor LM-6074  
ELVIS—Elvis Presley—RCA Victor LPM-1382  
PAT'S GREAT HITS—Pat Boone—Dot 3071/25071  
KINGSTON TRIO AT LARGE—Kingston Trio—Capitol T-1199  
KINGSTON TRIO—Kingston Trio—Capitol T-996  
MORE SING ALONG WITH MITCH—Mitch Miller—Columbia CL-1243/CS-8043  
HEAVENLY—Johnny Mathis—Columbia CL-1351/CS-8152  
WARM—Johnny Mathis—Columbia CL-1078/CS-8039  
LOVE IS THE THING—Nat King Cole—Capitol W-824  
HERE WE GO AGAIN—Kingston Trio—Capitol T-1258  
FROM THE HUNGRY I—Kingston Trio—Capitol T-1107  
SOUND OF MUSIC—Original Cast—Columbia KOL-5450/KOS-2020  
MERRY CHRISTMAS—Johnny Mathis—Columbia CL-1195/CS-8021  
STILL MORE SING ALONG—Mitch Miller—Columbia CL-1283/CS-8099

## 1959

HYMNS—Ernie Ford—Capitol T-256  
JOHNNY'S GREATEST HITS—Johnny Mathis—Columbia CL-1133  
MUSIC MAN—Original Cast—Capitol WAO/SWAO-990  
SING ALONG WITH MITCH—Mitch Miller—Columbia CL-1160/CS-8004  
SOUTH PACIFIC—Rodgers & Hammerstein—RCA Victor LOC/LSO-1032  
PETER GUNN—Henry Mancini—RCA Victor LPM/LSP-1956

## 1958

OKLAHOMA—Gordon MacRae—Capitol WAO-595

**SUBSCRIBE NOW  
AND RECEIVE THIS  
DIRECTORY ISSUE  
FREE**





# **James Brown**

**Americas No.1  
Soul Brother!**

**Current Best Selling Single**

**“Brother Rapp”**

King 6310

**Produced By:**

**James Brown Productions**

**Bookings:**

**Universal Attractions**

**200 West 57th St.**

**New York, N.Y.**

**Exclusively On  
KING RECORDS**

THIS IS  
The 28th Annual Edition of the  
WORLD WIDE CASH BOX DIRECTORY

... it's fresh  
off the press and out to the  
international entertainment industry  
with all the "who", the "how to" and  
the "where to go" information it requires.

If you're a regular  
subscriber, you've received your Directory.

If you  
don't subscribe . . . if you're sneaking a look at  
someone else's copy . . . then do yourself and your  
business a favor and check into this offer:

While your friend isn't  
looking clip the subscription blank from  
his copy of Cash Box, (Page 203) and send your check  
today to receive 52 weekly issues — PLUS — a  
personal complimentary copy of the 1970-71 Directory.

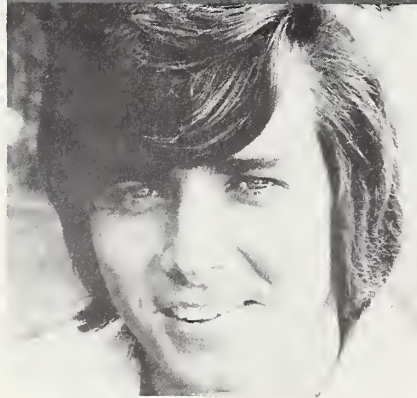
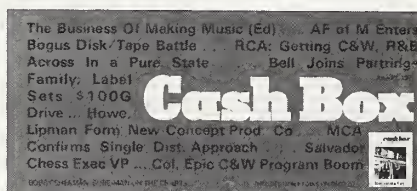

52  
REGULAR  
WEEKLY  
ISSUES  
FEATURING  
CURRENT  
NEWS AND  
TOPICAL  
CHART  
INFORMATION

28th  
ANNUAL  
DIRECTORY  
FROM COVER  
TO COVER  
THE BEST  
TRADE  
REFERENCE  
AVAILABLE

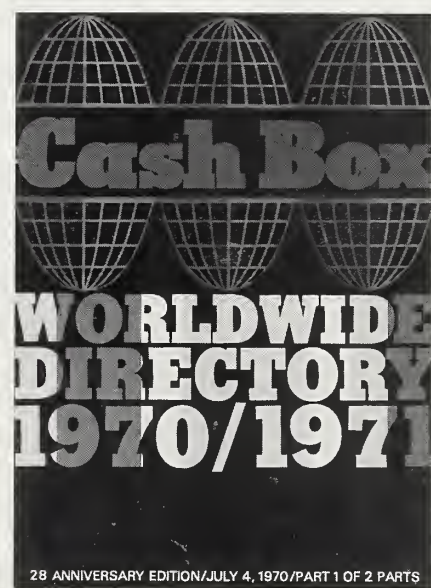

P. S. Your subscription will extend long enough into  
1971 to entitle you to receive the  
29th Anniversary Edition when it's published.

# CREWE GROUP OF COMPANIES

**CGC Records**  
Crewe Records

**Distribution:**  
Maxwell Records

**Crewe T.V. and Film**

**CGC Management**

**Publishing:**  
Saturday Music  
Tomorrow Tunes  
Genius Music

**1841 Broadway**  
**New York, N.Y. 10023**  
(212) CI-5-3535

*producers*  
of the  
**TOP  
100  
HITS**

Ashford, N.  
c/o Tamla/Motown  
2457 Woodward Ave  
Detroit, Mich.

**B**

Bacharach, Bert  
c/o Blue Seas  
254 W. 54 St.  
New York City

Band, The  
c/o Capitol  
1750 N. Vine  
Los Angeles, Calif.

Bari, Steve  
c/o ABC  
8255 Beverly Blvd.  
Los Angeles, Calif.

Barrett, Richard  
c/o Roulette  
17 W 60 St.  
N.Y.C., N. Y.

Barri, Steve - Sill, Joel  
c/o Dunhill Records  
8255 Bev. Blvd.  
Los Angeles, Calif.

Barry, Jeff  
Greenwich, Ellie  
729 7th Avenue  
New York City

Barry, Jeff  
c/o Steed  
729 7th Ave.  
New York City

Baylor, Johnny  
c/o Stax  
926 E. McLemore St.  
Memphis, Tenn.

Beach Boys  
c/o Reprise  
4000 Warner Blvd.  
Burbank, Calif.

Bell, Al &  
Nixon, Tom  
c/o Stax  
926 E. McLemore  
Memphis, Tenn.

Boettcher, Curt — Olsen, Keith  
c/o WB  
4000 Warner Blvd.  
Burbank, Calif.

Bowen, Jimmy  
6565 Sunset Blvd.  
Los Angeles, Calif.

Bramlett, Delaney  
c/o Atlantic  
1841 Broadway  
New York City

Briggs, David - Neil Young  
c/o Warner Bros.  
4000 Warner Blvd.  
Burbank, Calif.

Bright Tunes  
1697 Broadway  
New York City

Bristol, Johnny  
c/o Soul  
2457 Woodward Ave  
Detroit, Mich.

Brown, James  
c/o King  
1540 Brewster Ave  
Cinn. Ohio.

Burgess, John  
c/o Capitol  
1750 N. Vine  
Los Angeles, Calif.

Burns, Eileen - Paul Davis  
1650 Bway  
N.Y.C., N. Y.

Buster, Bill  
c/o Atlantic  
1841 Bway  
N.Y.C., N. Y.

Butler, Dick  
c/o U.A.  
729 7th Ave.  
New York City.

**C**

Cameron, J. & Johnson, C.  
c/o UNI  
8255 Sunset Blvd.  
Los Angeles, Calif.

Carter, Calvin  
c/o Checker Rec.  
320 E. 21st  
Chicago, Ill.

Cashman, Terry  
for Guardian Prod.  
c/o Event  
201 W. 54 St.  
New York City

Catalano, Tom  
16715 Charmell Lane  
Pacific Palisades,  
California.

Chandler, Gene  
1321 S. Michigan Ave.  
Chicago, Ill.

Charles, Ray  
c/o Tangerine  
2107 W. Washington Blvd.  
Nashville, Tenn.

(Con't. on next page)

**CONGRATULATIONS**

**on your**

**28th ANNIVERSARY**

**Jimmy Webb**

# Chicago

Walker & Parazade

Peter P. Cetera

James A. Brown

Robert W. Lamm

David Dinklage

Lee & Loughnone

Levy Keith



**The  
SAM RIDDLE  
NICK BRAINARD  
Companies**

**TELEVISION PRODUCTION**

**RECORD PRODUCTION**

**TALENT MANAGEMENT**

**CONCERT PRODUCTION**

6430 SUNSET BLVD.  
SUITE 916  
LOS ANGELES, CALIFORNIA 90028  
(213) 469-6287

*producers  
of the  
TOP  
100  
HITS*

**D**

Daniels, Chas. E.  
Sincere for BSM  
1501 Broadway  
New York City

Davis, Billy  
1619 Broadway  
New York, N.Y.

Davis, Carl  
Record, Eugene  
c/o Brunswick  
445 Park Ave.  
New York City

Davis, Don  
c/o Stax Records  
926 E. McLemore Ave.  
Memphis, Tenn.

David, Hal.  
c/o Blue Seas  
254 W. 54th St.  
New York City

Davies, Ray  
4000 Warner Blvd.  
Burbank, Calif.

DeAngelis, Peter  
c/o ABC  
1330 Ave of the Americas  
New York City

DeLory, Al  
c/o Capitol Records  
1750 N. Vine  
Hollywood, Calif.

Dougherty, Jack  
c/o A&M  
1416 N. La Brea  
Los Angeles, Calif.

Dowd, Tom  
c/o Atco Records  
1841 Broadway  
New York, N.Y.

Dozier, Eugene,  
Chambers, Roland  
For Gamble, Huff  
250 S. Broad St.  
Philadelphia, Pa.

**E**

Ebb-Tide-Jimmy  
Angel-Ron Shaab  
Baton Rouge, La.  
(3106 Belmont Blvd.  
Nashville, Tenn.)

Ertegun, Ahmet  
& Howe, Jackson  
c/o Atlantic  
1841 Broadway  
New York City

Ertegun-Joel Dorm  
c/o Atlantic  
1841 Broadway  
New York City

**F**

Fallon, Larry  
Kong, Leslie  
c/o A&M  
1416 N. La Brea Ave.  
Hollywood, Calif.

Farrell, Wes  
6430 Sunset Blvd.  
Los Angeles, Calif.

Feldman, Bob  
Graffin, Herman  
c/o Polydor  
1700 Broadway  
New York City

Fleetwood, Mac  
23 Alberle St.  
London, W.1. England

Fogerty, John  
c/o Fantasy Records  
1281 30th St.  
Oakland, Calif.

Fuller, Jerry  
c/o Columbia Records  
51 West 52nd St.  
New York, N.Y.

**G**

Gabriel, Mekler  
c/o Dunhill  
8255 Beverly Blvd.  
Los Angeles, Calif.

Gallucci, Don  
c/o Elektra  
1855 Broadway  
New York City

Gamble, Huff  
250 S. Broad Street  
Philadelphia, Pa.

Gargale, Jim  
c/o Mercury  
35 E. Wacker Drive  
Chicago, Ill.

Garfunkel, Arthur  
c/o Columbia  
51 West 52 St.  
New York City

Gates, David  
c/o Elektra  
15 Columbus Circle  
N.Y.C., N. Y.

Gaudio, Bob  
Presented by Bob Crewe  
1841 Broadway  
New York City

Gaye, Marvin  
c/o Soul  
2457 Woodward Ave.  
Detroit, Mich.

Gentrys & Phillips, K.  
c/o SSSI  
3106 Belmont Blvd.  
Nashville, Tenn.

(Con't. on next page)

# CONGRATULATIONS CASHBOX ON YOUR 28TH ANNIVERSARY!

Robin Hood Brians  
The Cascades  
Daybreak  
Neil Diamond  
Carol Dunn  
Durango  
Mark Eric  
Fever Tree  
Flaming Youth  
The Foundations  
John Fred and His Playboy Band  
Brian Hyland  
Deni Lynn  
Tommy Maris  
Dewey Martin  
Scotty McKay  
Billy Wade McKnight  
Thee Midnighters  
Ray Peterson  
Sandy & Dick St. John  
Pat Shannon

Strawberry Alarm Clock  
Sylvanus  
The Yellow Payges  
The Blue Notes  
Bob & Earl  
Betty Everett  
Darrow Fletcher  
Garland Green  
The Green Berets  
Marvin Holmes & The Uptights  
Jackie Lee  
The Lovelites  
The Passionettes  
The Sister & Brothers  
Marvin L. Sims  
Karl Tarleton  
Bill Cosby  
David Steinberg  
Gene Watson  
Duane Eddy  
Argosy  
Elton John



UNIVERSAL CITY RECORDS • A DIVISION OF MCA INC.

producers  
of the  
**TOP  
100  
HITS**

Glasser, D.  
c/o Columbia  
51 W. 52 St.  
New York City

Glasser, Dick  
6430 Sunset Blvd.  
Hollywood, Calif.

Glasser, Ted  
c/o Liberty  
6920 Sunset Blvd.  
Los Angeles, Calif.

Gordo  
c/o Kapp  
445 Park Ave.  
New York City

Greene, Marlin  
c/o Norala Recording Corp.  
102 E. 2nd St.  
Sheffield, Ala.

Greenway, Roger  
Cook, Roger  
539 W. 25th St.  
New York City

Guercio, James, Wm.  
c/o Columbia  
51 W. 52 St.  
New York City

## H

Hall, Rick  
603 E. Avalon  
Muscle Shoals, Ala.

Hayes, Isaac  
c/o Volt  
926 E. McLemore Ave.  
Memphis, Tenn.

Henderson, Willie  
c/o Dakar  
1449 S. Michigan Ave.  
Chicago, Ill.

Hendricks, James  
c/o MGM  
6331 Hollywood Blvd.  
Los Angeles, Calif.

Herston, Kelso  
c/o Capitol Records  
1750 N. Vine  
Hollywood, Calif.

Hideout  
c/o Gear  
750 N. Vine  
Los Angeles, Calif.

Hildebrandt, H.  
c/o Probe  
1930 Ave of the Americas  
N.Y.C., N. Y.

Hill, John  
c/o Columbia  
51 W. 52nd St.  
N.Y.C.

Hiller, Tony  
c/o Belwin Mills  
539 W. 25th St.  
N.Y.C.

Holland-Dozier-Holland  
c/o Invictus  
2601 Cadillac Tower  
Detroit, Mich.

Hosea, Don  
804 16th Ave.  
S. Nashville, Tenn.

Howe, Bones  
8833 Sunset Blvd.  
Los Angeles, Calif.

Huff, Gamble  
200 S. Broad St.  
Phila., Pa.

## I

Isley Bros.  
c/o Buddah  
1650 Broadway  
N.Y.C.

## J

Jackson, Billy  
c/o Columbia  
51 West 52 St.  
N.Y.C., N.Y.

Jacobsen, Erik  
c/o Great Honesty  
4000 Warner Blvd.  
Burbank, Calif.

James, Tommy  
for Gulf Pacific  
c/o White Whale  
8961 Sunset Blvd.  
Los Angeles, Calif.

Johnston, Bob  
c/o Columbia  
51 W. 52nd St.  
N.Y.C.

Jones, Booker T.  
c/o Stax Records  
926 McLemore Ave.  
Memphis, Tenn.

J. R. Enterprises Inc.  
P. O. Box 6128  
Nashville, Tenn.

Ju-Nat Prod.  
c/o Capitol  
1750 N. Vine  
Hollywood, Calif.

## K

Killen, Buddy  
c/o Tree Music  
905 16th Ave. So.,  
Nashville, Tenn.

Knight, Sonny  
c/o Columbia  
51 West 52 St.  
N. Y. C.

Krasnow, Bob  
c/o Blue Thumb  
427 N. Canyon Dr.  
Beverly Hills, Calif.

## L

Lane, Brian  
c/o Capitol  
1750 N. Vine  
L. A., Calif.

Loboe-Barrett  
c/o Orig. Sound  
7120 Sunset Blvd.  
Hollywood, Calif.

Lambert-Chris-Stamp (London)  
445 Park Ave.  
N. Y. C.

Lathower, Maurie  
c/o Capitol  
1750 N. Vine St.  
Los Angeles, Calif.

Lee  
c/o Ides  
4000 Warner Blvd.  
Burbank, Calif.

Leka, Paul  
For Heather Prod.  
c/o Decca Records  
445 Park Ave.  
New York, N.Y.

Lindsay, Mark  
9125 Sunset Blvd.  
Los Angeles, Calif.

## M

Mann, Barry  
711 5th Ave.  
N.Y.C., N. Y.

McBride, Robin  
c/o Mercury  
35 E. Wacker Drive  
Chicago, Ill.

McCoy, Van  
341 N. Woodland St.  
Engelwood, N.J.

McLaughlin, Ollie  
Fabulous Counts  
c/o McLaughlin  
1841 Broadway  
N.Y.C.

Macaulay, Tony  
c/o Bell  
1776 Broadway  
N.Y.C.

MacLeod, J.  
c/o Congress  
8255 Sunset Blvd.  
Los Angeles, Calif.

Mardin, Arif  
c/o Atlantic Records  
1841 Broadway  
New York, N.Y.

The Marmalade  
c/o Decca Ltd.  
9 Albert Embankment  
London SE1, Eng.

Mayfield, Curtis  
c/o Buddah  
8543 Stoney Island Ave  
Chi., Ill.

McCoy, Marie  
1619 Broadway  
New York City

Mekler, Gabriel  
c/o Dunhill  
8255 Bev. Blvd.  
Los Angeles, Calif.

Merenstein, Lewis  
57 W 56 St.  
N.Y.C., N. Y.

Miller, Bill  
c/o Capitol  
1750 N. Vine St.  
Hollywood, Calif.

Miller, Bobby  
c/o Cadet Records  
320 E. 21st St.  
Chicago, Ill.

Miller, Helen  
1619 Broadway  
New York, N.Y.

Mills, Jackie  
6430 Sunset Blvd.  
Hollywood, Calif.

Monaco, Bob  
for Dunwich  
25 E. Chestnut,  
Chicago, Ill.

Moman, Chips  
American Group Prod.  
6920 Sunset Blvd.  
Los Angeles, Calif.

Montgomery, Bob  
c/o United Artists  
722 17th Ave. S.  
Nashville, Tenn.

Morgan Music Prod.  
c/o Phillips  
35 E. Wacker Dr.  
Chicago, Ill.

Morgan, Tom  
c/o Decca  
445 Park Ave.  
N.Y.C.

Morrison, Van  
c/o Warner Bros.  
4000 Warner Blvd.  
Burbank, Calif.

Most, Mickie  
c/o ABKO Industries  
1700 Broadway  
N.Y.C.

## N

Nazz, The  
c/o Screen Gems/Columbia  
711 5th Ave.  
N.Y.C.

Nelson, Ken  
c/o Capitol  
1750 N. Vine  
Los Angeles, Calif.

Nelson, Rick-Sutton Joe  
c/o Decca  
445 Park Ave.  
N.Y.C.

## O

Owens, B.  
c/o Wes Farrell  
39 W 55 St.  
N.Y.C.

## P

Pappalardi, Felix  
161 W. 54 St.  
N.Y.C.

Philips, Knox  
c/o Shelby Singleton  
817 16th Ave.  
S. Nashville, Tenn.

Pistilli, Gene  
For Guardian Prod.  
c/o Event  
201 W 54 St. N.Y.C.

Podolor, Richard  
for Big Foot Prod.  
1841 Broadway  
N.Y.C.

Presley, Elvis  
1133 Ave. of Americas  
N.Y.C.

(Cont. on next page)



*Happy Anniversary!*



**Ed  
Ames**

**RCA**

*producers  
of the  
TOP  
100  
HITS*

**R**

Redd, Gene  
200 W. 57 St.  
N.Y.C.

Rice, T. & Webber, A.L.  
445 Park Ave.  
NYC

Richards, Ron  
108 Park Street  
London W1 England

Richardson, Jack  
c/o Nimbus 9  
131 Hazelton Ave.  
Toronto, Canada

Rick, Don  
8949 Stoney Island Ave.  
Chicago, Ill.

Robinson, D.  
c/o Atlantic  
1841 Broadway  
N.Y.C.

Roger East Jerry & DesChamp  
(London England)  
1776 Broadway  
N.Y.C.

Ross, Jerry  
1790 Broadway  
N.Y.C.

Rothchild, Paul  
c/o Elektra Records  
1855 Broadway  
New York, N.Y.

Rubinson, David  
c/o Atlantic  
1841 Broadway  
N.Y.C.

Russell, Leon  
Cordell, Denny  
c/o N La Brea  
Los Angeles, Calif.

Russell, Sam  
Hunt, Irving  
c/o Imperial  
6920 Sunset Blvd.  
Los Angeles, Calif.

**S**

Sandlin, Johnny  
c/o Atco  
1841 Broadway  
N.Y.C.

Santana & Dangerfield, Brent  
51 W. 52nd St.  
N.Y.C.

Bob Scaaf - George Butler &  
Little Anthony & Imperials  
729 7th Ave.  
N.Y.C.

Schnekeryk, Peter  
c/o Buddah  
1650 Broadway  
N.Y.C.

Scott, Joe  
2809 Erastus St.  
Houston, Texas

Sehorn, Marshall E.  
Toussaint, Allen  
c/o Rhinelander  
1790 Broadway  
N.Y.C.

Schroeder, John  
c/o Pye Records  
London, England

Shanklin, J. R.  
for Golden Age  
1610 N. Argyle  
Hollywood, Calif.

Sherrill, Billy  
c/o Epic Records  
51 W. 52nd St.  
New York, N.Y.

Shocking Blue/Pink Elephant  
in association with Jerry Ross  
c/o Colossus  
1855 Broadway  
N.Y.C.

Simon, Paul  
c/o Columbia  
51 West 52nd St.  
N.Y.C.

Simpson, V.  
c/o Tamla/Motown  
2457 Woodward Ave.  
Detroit, Mich.

Singleton, Shelby  
3106 Belmont Blvd.  
Nashville, Tenn.

Sixuvus,  
c/o Kama Sutra  
1650 Broadway  
N.Y.C.

Solomon, Seymour  
c/o Vanguard  
71 W. 23 St.  
N.Y.C.

Spector, Phil  
c/o ABKO Industries  
1700 Broadway  
N.Y.C.

Spirit  
51 W. 52nd St.  
N.Y.C.

Stage Coach  
2601 Cadillac Tower  
Detroit, Mich.

Stanton, Allen  
c/o A&M  
1416 N. La Brea  
Los Angeles, Calif.

Stan & Bell  
c/o Nickle Shoe  
261 S. 52nd St.  
Phila, Pa.

Stephanye/Delite  
300 W. 55th St.  
N.Y.C.

Stevens, Ray  
for AHAB  
c/o Columbia  
51 W. 52nd St.  
N.Y.C.

Stone, Sly  
for Stone/Flower  
700 Urbano  
San Francisco, Calif.

Stroud,  
c/o RCA  
507 5th Ave.  
N.Y.C.

Sullivan, Peter  
for Gordon Mills  
24-25 New Bond St.  
London W1 England

Sylvia Prod.  
106 W. Palisades Ave.  
Englewood, N.J.

Szymczyk, Bill  
c/o Bluesway  
8255 Beverly Blvd.  
Los Angeles, Calif.

**T**

Taylor, Creed  
36 E. 59th St.  
N.Y.C.

Testa, Vinny  
888 8th Ave.  
N.Y.C.

Thompson, Carrie  
c/o Buddah  
1650 Broadway  
N.Y.C.

Toussaint, A.R.-M.E. Sehorn  
1211 St. Philips St.  
New Orleans, La.

T.S.R. For Jerry Ross  
c/o Colossus  
1855 Broadway  
N.Y.C.

Tuft-Paul White  
c/o Capitol  
1750 N. Vine  
L.A. Calif.

Turner, Ike  
c/o Minit  
6920 Sunset Blvd.  
Los Angeles, Calif.

**V**

Valvano, M.  
539 W. 25th St.  
N.Y.C.

Vance, P. & Pockress, L.  
N.Y.C.

Vincent, Stan  
300 W. 55 St.  
N.Y.C.

**W**

Walker, Noel  
Davis, Billy  
c/o World Pacific  
6920 Sunset Blvd.  
L.A. Calif.

Wellington, Jay  
c/o Duke  
2809 Erastus St.  
Houston, Texas

West, Tommy  
for Guardian Prod.  
c/o Event  
201 W. 54 St.  
N.Y.C.

Wexler, Jerry  
c/o Atlantic Records  
1841 Broadway, New York N.Y.

Whitfield, Norman  
c/o Tamala Motown  
2457 Woodward Ave.  
Detroit, Mich.

Wilde, Christian  
c/o Wild  
8255 Sunset Blvd.  
Los Angeles, Calif.

Williams, J.Jr.  
c/o Canyon  
1242 N.Highland  
Los Angeles, Calif.

Wilson, Frank  
c/o Tamla/Motown  
2457 Woodward Dr.  
Detroit, Mich.

Womack, C & M  
1790 Broadway  
N.Y.C.

Wonder, Stevie  
c/o Tamla  
2457 Woodward Ave.  
Detroit, Mich.

Woods, Gilda  
c/o Brenda & Tabulations  
919 N. Broad St.  
Phila., Pa.

Wright, Chas.  
c/o Wright Gerstele  
4000 Warner Blvd.  
Burbank, Calif.

Wright, Peter, H.  
Bendo, Howard  
c/o Mercury  
35 E. Wacker Dr.  
Chicago, Ill.

**PROGRAMME**

**ONE TOO MANY MORNINGS  
ALONG COMES MARY  
I'LL BE YOUR MAN  
GOODBYE COLUMBUS  
GET TOGETHER  
WASN'T IT A BIT LIKE NOW  
NEVER MY LOVE  
GOODBYE FOREVER  
JUST ABOUT THE SAME  
BABE, I'M GONNA LEAVE YOU  
SEVEN MAN BAND  
TIME IT IS TODAY  
DUBUQUE BLUES  
BLISTERED  
WHAT WERE THE WORDS  
REMEMBER  
ARE YOU READY  
CHERISH  
REQUIEM FOR THE MASSES  
ENTER THE YOUNG  
WINDY  
and a few surprises**

*on Warner Bros.  
Records & Tapes*



THE

ASSOCIATION

OF  
LAWYERS

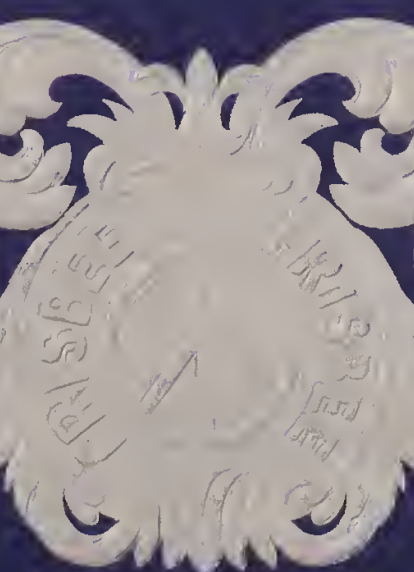





Thank You  
For Another Year  
**Bobby Vinton & Friend**

On Epic Records and Tapes.

# TAPE DISTRIBUTORS

## CALIFORNIA

### Los Angeles

ABC Record & Tape  
3334 La Cienega Pl.  
L.A. 90016  
(213) 870-8711

Car Tapes  
9180 Kelvin Ave.  
Chatsworth 91311  
(213) 882-8722

Car Tapes  
16725 Roscoe Blvd.  
Sepulveda, Calif.  
(213) 894-8368

Contact San Diego, Inc.  
345 - 6th Avenue  
San Diego  
(714) 234-1538

Craig Corp.  
3410 La Glenega Blvd.  
(213) 936-6171

Discount Record Ctr.  
Wilshire & La Cienega  
(213) 652-4441

Handleman Company  
1550 N. Knowles Avenue  
(213) 261-0268

Merrec Distributors, Inc.  
2617 South Broadway  
(213) 748-9821

Muntz Cartridge City  
15601 Roscoe Blvd.  
Van Nuys, Calif.

Music Merchandisers of America, Inc.  
22433 S. Vermont Ave.  
Torrance  
(213) 320-8400

RCA Distrib. Corp.  
6051 Telegraph Rd.  
(213) 723-6661

Rapid Merchandising, Co.  
1802 American Street  
Anaheim  
(714) 879-4070

Sears, Roebuck & Company  
2650 E. Olympic Blvd.  
(213) 268-5211

Tape Merchandisers  
2565 West Pico Blvd.  
(213) 385-9161

Transcontinental Music Corp.  
15500 South Main Street  
Gardena 90061  
(213) 321-6260

United Tape Corp.  
(Subsidiary of Nat'l Tape Distrib., Inc.)  
22433 So. Vermont  
Torrance 90507  
(213) 775-7591

United Tape & Instrument  
5873 Rodeo Road  
(213) 870-0246

Wallich's Music City  
Sunset & Vine  
(213) 462-2181

### San Francisco

H. R. Basford  
800 Mariposa  
(415) 621-8545

California Auto Accessories  
500 Ellis  
Mtn. View  
(415) 961-6826

California Auto Sound  
5810 Stockton Blvd.  
Sacramento  
(916) 422-4675

Craig Corp.  
215 Littlefield  
So. San Francisco  
(415) 589-3660

Merrec Distributors, Inc.  
1485 Bay Shore Boulevard  
(415) 467-1150

Music West  
460 Talbert  
Daly City  
(415) 467-5800

National Tape & Record of Calif.  
(Subsidiary of National Tape Distributors, Inc.)  
324 Harbor Way  
South San Francisco  
(415) 589-5667

Pic-A-Tune  
1461 Park  
Emeryville  
(415) 654-5110

The Tape Deck  
4646 El Camino Real  
Los Altos  
(415) 941-3511

Tip Top Music Co.  
900 Minnesota Street  
(415) 285-1400

T.M.C.  
868 Cowan Rd.  
Burlingame,  
(415) 589-3660

Tower Records  
2525 Jones St.  
(415) 885-0500

Transcontinental  
868 Cowan Rd.  
Burlingame 94010  
(415) 697-6800

## COLORADO

ABC Record & Tape  
10625 E. 47th Ave.  
Denver 80216  
(303) 343-7822

Active Electronics  
1111 S. Platte River Drive  
Denver  
(303) 733-7203

Craig  
4959 Colorado Blvd.  
Denver 80216  
(303) 399-0434

Merrec Distributors, Inc.  
811 Lincoln Street - Suite 401  
Denver  
(303) 534-1321

Pan American Mile Hi  
77 Kalamath  
Denver  
(303) 255-2021

Ward Terry & Co.  
70 Rio Grande Blvd.  
Denver  
(303) 266-3181

Transcontinental Music Corp.  
1111 So. Platte River Dr.  
Denver 80204  
(303) 733-7203

## CONNECTICUT

Arrow Auto  
560 New Park Ave.  
W. Hartford  
(203) 236-1901

Champion Auto  
125 Whalley Ave.  
New Haven  
(203) 865-1171

Eastern Record Dist. Inc. (div. of Transcon)  
734 Tollard St.  
E. Hartford  
(203) 289-8631

Park Records  
274 Park Ave.  
E. Hartford 06108  
(203) 289-9361

Transcontinental  
734 Tollard St.  
E. Hartford 06108  
(203) 289-8631

## DISTRICT OF COLUMBIA

District Records, Inc.  
2146 24th Place N.E.  
(202) 832-3600

## FLORIDA

Campus Record Distributing Corp.  
7250 N.W. 36th Avenue  
Miami  
(305) 691-3140

Copa Corporation  
858 West Flagler Street  
Miami  
(305) 377-2529

Dabill Tape Service (rack)  
115 W. Adams St.  
Jacksonville 32202  
(904) 356-0855

Harold Friedman Radio  
7100 N.W. 10th Ave.  
Miami  
(305) 754-4595

Halsey & Griffith  
317 Datura St.  
W. Palm Beach  
(305) 832-3883

Handleman Company  
2346 N.W. 147th Street  
Opa Locka 33054  
(305) 681-4618

Muntz Stereo Tape  
72 N.W. 79th St.  
Miami  
(305) 751-0211

Record Supply Company  
290 Iris Road  
Casselberry  
(305) 831-1116

Sea Coast Appliance  
3575 N.W. 60th St.  
Miami  
(305) 635-0951

Southern Record Services  
1020 E. 14th Street  
Hialeah  
(305) 885-4625

Stereo Panorama  
3800 N. Skyway Blvd.  
St. Petersburg  
(813) 527-1111

Tape Town  
4115 Henderson Blvd.  
Tampa  
(813) 872-8444

Techni Service  
1813 So Dixie Highway  
W. Palm Beach  
(305) 832-1769

Thurrow Electric  
121 S. Water St.  
Tampa  
(813) 229-1885

Transcontinental Music Corp.  
684 Edgewood Avenue North  
Jacksonville 32205  
(904) 388-8492

T.M.C.  
8160 N.W. 36th Ave.  
Miami 33147  
(304) 696-6261

United Rec. & Tape  
9880 N.W. 77th Ave.  
Hialeah Gardens  
(305) 821-3100

## GEORGIA

ABC Record & Tape  
720 14th St. N.W.  
Atlanta 30318  
(404) 875-5565

All Star Distributing Company  
492 Roswell Street  
Marietta  
(404) 427-7224

Clarksville Record Sales  
198 Main Street  
Clarksville  
(404) 754-2152

Gate City Record Service  
1231-D Collier Road, N.W.  
Atlanta  
(404) 351-4821

## ALABAMA

Rack Service Merchandisers  
3801 Moffet Road  
Mobile, Ala.  
(205) 478-0466

## ARIZONA

Arizona Western (a div. of Arizona Sundries)  
2950 No. 30th Ave.  
Phoenix, Ariz 85017  
(602) 272-1383

Associated Distribs.  
3803 N. 36th Ave.  
Phoenix 85019  
(602) 278-5584

T.M.C.  
3036 No. 30th Ave.  
Phoenix 85107  
(602) 272-9343

## ARKANSAS

Bill Fisher Auto  
2905 Cantrell Rd.  
Little Rock, Ark. 72202  
(501) 664-0275

Siebert  
6301 Forbing Rd.  
Little Rock 72204  
(501) 565-5521

# ALLTAPES, INC.

SUPER SERVICE with the FIRST & MOST EXPERIENCED  
Jobber & One-Stop in Reel-to-Reel, Cassettes and Cartridge  
Tapes in the MIDWEST HANDLING ALL LINES.

AMPEX — RCA VICTOR — CAPITOL — COLUMBIA -- DECCA — MERCURY, ETC.

2623 N. Pulaski Rd. — Chicago, Ill. 60639 — Phone: (312) 342-6600

(Con't. on next page)



# BENAFONNE

**RCA**

Public Relations Direction  
MIKE MERRICK CO., INC.

# TAPE DISTRIBUTORS

Godwin Dist.  
1227 Spring St. N.W.  
Atlanta  
(404) 876-5719

Handleman  
1532 Stoneridge Dr.  
Stone Mountain 30083  
(404) 938-9467

L & F Record Service  
720 - 14th Street, N.W.  
Atlanta  
(404) TR 5-5565

Merrec Distributors, Inc.  
2285 Peachtree Road, N.W.  
Atlanta  
(404) 355-0243

National Tape & Record of Ga., Inc.  
(Subsidiary of Nat'l Tape Distrib., Inc.)  
2201 Faulkner Road N.E.  
Atlanta 30324  
(404) 634-6121

RCA Dist. Corp.  
1500 Marietta Blvd. N. W.  
Atlanta  
(404) 355-2960

Sound Marketing  
2144 Faulkner Rd. N.E.  
Atlanta  
(404) 636-5971

Southeast Georgia Parts  
4111 Bull Street  
Savannah  
(912) 233-6653

## HAWAII

Music Craft Distributors Of Hawaii Ltd.  
636 Queen Street  
Honolulu

Radio-TV Corp.  
432 Keawe St.  
Honolulu  
50-2901

## ILLINOIS

ABC Record & Tape  
P.O. Box 66186  
Chicago 60606  
(312) 439-9200

All Tapes  
2623 N. Pulaski  
Chicago 60639  
(312) 342-6600

Cartapes  
320 W. Ohio St.  
Chicago  
(312) 943-5158

London Records  
2419 S. Michigan Ave.  
Chicago  
(312) 842-4440

Galgano Distributing Co.  
4135 West Armitage Avenue  
Chicago  
(312) 342-7060

Handleman Companu  
3477 West Touhy Avenue  
Lincolnwood 60645  
(312) 583-0770

Hit Records, Inc.  
10614 South Mackinaw Avenue  
Chicago  
(312) 734-2244

Intercontinental Marketing Corp.  
2834 South Lock  
Chicago  
(312) 376-9660

Klaus Radio & Electric Company  
8400 N. Pioneer Parkway  
Peoria  
(309) 691-4840

London Records Midwest  
2419 South Michigan Avenue  
Chicago  
(312) VI 2-4440

Merrec Distributors, Inc.  
540 North Lake Shore Drive  
Chicago  
(312) 329-9161

Profit Vendors  
3216 W. Lawrence Avenue  
Chicago  
(312) 478-6114

Musical Isle Record Corp.  
1550 South State Street  
Chicago  
(312) 225-2929

RCA Distributing  
424 E. Howard Ave.  
Des Plaines  
(312) 827-0033

Sears, Roebuck & Company  
925 South Homan  
Chicago  
(312) 265-2500

Selected Tapes  
120 King St.  
Elk Grove  
(312) 439-9200

Tape Dist. of America  
3035 W. 47th St.  
Chicago 60632  
(312) 254-4612

T.M.C.  
5301 Danshere Rd.  
Country Side 60525  
(312) 354-6804

Universal Music Corp.  
9047 N. Terminal  
Skokie  
(312) 965-1810

## INDIANA

Associated  
210 S. Meridian St.  
Indianapolis  
(317) 634-2593

Cartapes  
211 E. State Blvd.  
Ft. Wayne 46805  
(219) 484-2922

Sound Classics  
333 W. 9th Street  
Indianapolis  
(317) 634-2591

## IOWA

ABC Record & Tape  
1520 Walnut St.  
Des Moines 50309  
(515) 288-7001

J. L. Marsh of Iowa, Inc.  
1630 Locust Street  
Des Moines  
(515) 288-0182

## KANSAS

RCA Distributing  
Old Santa Fe Trail & 102nd St.  
Shawnee Mission  
(913) 888-1440

Spaceage Enterprises  
2504 E. Keillogg  
Wichita  
(316) 683-2600

Transcontinental Music Corporation  
2955 S. Kansas Avenue  
Wichita 66106  
(316) LY 1-3414

## KENTUCKY

Arthur Fulmer  
950 S. 3rd Street  
Louisville  
(502) 584-0263

Handleman Company  
4500 Louisville Avenue  
Louisville 40209  
(502) 361-1336

## LOUISIANA

All South Distributing Co.  
1924 Lafayette Street  
New Orleans  
(504) 522-1157

B & B Parts Sales  
211 N. Market Street  
Shreveport  
(318) 422-9382

Louisiana A. S. C.  
1500 Airport Dr.  
Shreveport

McDonald Sales  
5500 Jefferson Hwy.  
(504) 733-6653

Modern Record Service  
757 Central Avenue  
New Orleans  
(318) 234-3291

Muntz Tape City  
540 East King's Highway  
Shreveport

Stan's Tape Center  
728 Texas St.  
Shreveport

Tape City U.S.A.  
1112 McArthur Dr.  
Alexandria

Tape City U.S.A.  
4230 Veteran's Highway  
Metairie

Tape City U.S.A.  
6237 Clairborne Ave.  
New Orleans

## MAINE

Commercial Dist.  
50 Diamond St.  
Portland  
(207) 775-5644

## MARYLAND

Chase Marketing Co.  
4980 Wyaconda Road  
Rockville  
(301) 933-5880

D & H Dist.  
2500 Schuster Dr.  
Cheverly  
(301) 322-3500

Lawrence Associates, Inc.  
11411 Amherst Avenue  
Wheaton  
(301) 949-4014

(Con't on next Page)



# CASCOM

offers you

## Custom Tape Duplicating

8 Track—Cassettes

MASTERING \* PACKAGING \* WAREHOUSING \* SHIPPING

**Full Creative Services  
For Education & Industry**

AUDIO VISUAL \* DESIGN \* SCRIPTING

National Distributors Of:

### GOLDEN BOOK & TAPE SETS

Golden Tape Favorites  
Vox Classical Series

Folkways  
Orpheum, Yew & Others

## CASSETTE COMMUNICATIONS CORP.

932 Broadway; New York, N.Y. 10010; (212) 533-3150





Personal Management: **NICK SEVANO**

Public Relations:  
**Titro/Levinson**

# TAPE DISTRIBUTORS

Merrec Distributors, Inc.  
375 Elliot Street  
Newton, Upper Falls  
(617) 969-6505

North East Records  
185 Riverside Avenue  
Somerset  
(617) 676-3061

Stereo Tape Center  
1068 Purchase St.  
New Bedford  
592-8569

Tape Place  
916 Providence Hwy.  
Dedham  
326-6065

Transcontinental  
30 Nashua St.  
Woburn 08101  
(617) 935-4700

## MICHIGAN

Auto Sound Distributors  
20232 Livernois Ave.  
Detroit 48221  
(313) 864-2892

Handleman Company  
670 E. Woodbridge  
Detroit 48226  
(313) 961-9563

Handleman Co.  
4604 North East St.  
Lansing 48906  
(517) 484-1386

Jay Kay Distributing Company  
13401 Lyndon  
Detroit  
(313) 273-7000

Lear-Jet Industries  
13131 Lyndon Ave  
Detroit  
(313) 345-7420

Monroe Distributing Co.  
2431 Clyde Park, S.W.  
Grand Rapids  
(616) 452-9744

RCA Distrib.  
27000 Trolley Dr.  
Taylor  
(313) 291-7100

Radio Electronic Supply  
505 Jefferson Avenue, S. E.  
Grand Rapids  
(616) GL 9-4611

Royal Stereo Tape Co.  
2950 West Davison  
Detroit 48238  
(313) 883-6565

## MINNESOTA

Bigelow Sales  
11950 12th Ave. S.  
Burnsville 55378  
(612) 890-6161

Creative Merchandising & Publishing  
1421 Park Avenue  
Minneapolis  
(612) 335-4186

Heilicher Brothers  
7600 Wayzata Boulevard  
Minneapolis 55426  
(612) 544-4201

J. L. Marsh Inc.  
7600 Wayzata Blvd.  
Minneapolis  
(612) 544-4201

Rapid Merch. Co.  
8175 Lewis Rd.  
Minneapolis  
(612) 544-3561

## MISSOURI

ABC Record & Tape  
2901 Grand St.  
Kansas City 64108  
(816) 931-7652

CMC Records & Tape  
Lindbergh-Warson Industrial Ctr.  
1201 Research Blvd.  
St. Louis 63132  
(314) 997-0016

Commercial Music Company  
2020 Delmar Boulevard  
St. Louis  
(314) 241-8618

Custom Music  
1201 Research Blvd.  
St. Louis  
(314) 997-0016

Davidson's One Stop  
321 Southwest Blvd.  
Kansas City  
(816) V12-5220

Arthur Fulmer  
311 South 14th Street  
St. Louis  
(314) 241-3575

Carl Galler  
5319 Troost St.  
Kansas City  
(816) 333-8787

Handleman Company  
1125 Saline Street  
North Kansas City 64116  
(816) 421-0135

Interstate Supply  
2218 So. Jefferson  
St. Louis  
(314) 776-1020

National Auto Sound  
5319 Troost  
Kansas City  
(816) 333-8787

Pat's One Stop Records  
1911 Washington Avenue  
St. Louis  
(314) CE 1-2074

Recco, Inc.  
1306 West 39th  
Kansas City  
(816) 561-7920

Show-Me Electronics  
Route 72  
Rolla  
(314) 364-3896

## MONTANA

Interstate Distributing Company  
457 Daniels Street  
Billings  
(406) 245-5141

## NEBRASKA

Sidles Co.  
7302 Pacific St.  
Omaha  
(402) 393-2233

## NEVADA

National Tape  
400 Glendale Rd.  
Reno 89505  
(702) 359-2151

## NEW JERSEY

ABC Record & Tape  
7025 Colonial Hwy.  
Pennsauken 08109  
(609) 663-0720

All-State New Jersey, Inc.  
321 Sherman Avenue  
Newark  
(201) BI 2-6500

Associated Records Corp.  
1721 N. Olden Avenue, Ext.  
Trenton  
(609) 882-1660

Atlas-Rand Corp.  
2 Keystone Pl.  
Paramus  
(201) 262-7500

Chancellor, Inc.  
8 Spielman Road  
Fairfield  
(201) 227-4010

Garden State Records  
68 W. Passaic Street  
Rochelle Park  
(201) 843-2670

Handleman Company  
7135 Colonial Lane  
Pennsauken 08109  
(609) 665-5460

J & J Corporation  
333 Clinton Place  
Newark  
(201) 926-3700

Krich-N.J. Inc.  
428 Elizabeth Ave.  
Newark  
(201) 248-7400

Merrec Distributors, Inc.  
9 Amendola Drive  
Netcong  
(201) 347-2328

National Tape & Record of N.J., Inc.  
(subsidiary of Nat'l Tape Distributors Inc.)  
609 Commerce St.  
Linden 07036  
(414) 342-3188

(Con't on next Page)

HY 7-2320

EM 6-8171

# CASSETTE & TAPE LABELS

RECORD LABELS and JACKETS

PROGRESSIVE LABEL & LITHO CO.      RECORD ALBUMS, INC.  
286 Stanhope St., B'klyn, N.Y.

CONGRATULATIONS ON YOUR 28th

# TAPE MERCHANDISING COMPANY INC.

5873 Rodeo Rd.  
Los Angeles, Calif. 90016  
(213) 870-0246

For the Best Service and Most Complete "Fill" in the Country

# Thanks For Listening

Welcome To A Whole New Thing:

## "Wherefore And Why"

Latest Single Release

**Johnny Mathis**  
**Raindrops**  
**Keep Fallin'**  
**On My Head**



including:  
Midnight Cowboy  
Bridge Over  
Troubled Water  
Honey Come Back  
Odds And Ends  
Alfie

CS 1005

**JOHNNY MATHIS**  
LOVE THEME FROM  
**"ROMEO AND JULIET"**  
(A TIME FOR US)  
INCLUDING:  
AQUARIUS/LET THE SUN SHINE IN  
LOVE ME TONIGHT/DIDN'T WE  
THE WINDMILLS OF YOUR MIND  
I'LL NEVER FALL IN LOVE AGAIN



CS 9909

**Johnny Mathis**  
**The Impossible Dream**

including:  
On A Clear Day You Can See Forever  
I Will Wait For You/Strangers In The Night  
Somewhere, My Love/Eleanor Rigby



CS 9872

**Johnny Mathis**  
**People**

INCLUDING:  
SUNNY/LAURA  
THE SHADOW OF YOUR SMILE / MORE  
WHAT THE WORLD NEEDS NOW IS LOVE



CS 9871

**JOHNNY'S  
GREATEST HITS  
JOHNNY MATHIS**

Including:  
The Twelfth of Never  
It's Not for Me to Say  
Chances Are  
Wonderful! Wonderful!  
When Sunny Gets Blue



CL 1133 / CS 8400

# TAPE DISTRIBUTORS

## NEW YORK

ABC Record & Tape  
46-50 54th Ave.  
Maspeth, N.Y. 11378  
(212) 786-6255

Almor Playtime Co.  
Wallins Corners Road  
Amsterdam  
(518) 842-2500

Alpha Dist.  
20 West End Ave.  
NYC 10023  
(212) 586-6200

Bee Gee Dist.  
10 Northway Lane N.  
Latham  
(518) 785-1350

Brun-International Recotape  
460 W. 34th St.  
NYC 10001  
(212) 564-3062

Fine Tone  
7111 20th Ave.  
Brooklyn  
(212) 331-3003

Gem Electronics  
34 Hempstead Turnpike  
Farmingdale  
(516) 249-6996  
249-9545

General Electric Company  
Electronic Sales Operation  
Building #1 - Electronics Park  
Syracuse  
(315) 456-3451

Interphoto Corporation  
45-17 Pearson Street  
Long Island City  
(212) 392-7600

Kartridge Audio, Inc.  
823 E. Gunhill Rd.  
Bronx  
(212) 547-9009

Merco Enterprises  
536 Broad Hollow Road  
Melville  
(516) 694-8990

Merrec Distributors  
Woodview Drive  
Colden  
(716) 853-2447

Merrec Distributors  
32-02 Queens Blvd.  
Long Island City  
(212) 729-6660

Morris Dist. Co.  
1153 W. Fayette St.  
Syracuse  
(315) 475-6531

Nat'l Tape Distributors  
1250 Broadway  
NYC 10001  
(212) 239-4547

Norelco Service, Inc.  
100 E. 42nd Street  
Long Island City  
(212) OX 7-3600

One Stop Tape Center  
1790 Main Street  
Buffalo  
(716) 883-1136

RTA Dist. Inc.  
991 Broadway  
Albany  
(518) 463-3251

Scott Distributing Corp.  
4245 Austin Blvd.  
Island Park, L.I. 11558  
(516) 432-1234

Tape Rac  
24 Brooklyn Ave.  
Freeport, L.I.  
(516) 868-0491

Transcontinental Distrib. Corp.  
100 Watervliet Avenue  
Albany 12206  
(518) 438-3571

Transcontinental Distrib. Corp.  
201 E. 42nd St.  
NYC 10017  
(212) OX 7-8610

Wally's Auto  
645 11th Ave.  
NYC  
(212) 582-6118

Westchester Stereo  
87 Central Ave.  
White Plains  
(914) 761-7569

## NORTH CAROLINA

Bib Dist. Co.  
126 W. Morehead St.  
Charlotte  
(704) 372-2032

Car Tronics  
738 Bragg Blvd.  
Fayetteville  
(919) 485-4209

Carolina One-Stop  
201 E. Main  
Durham  
(919) 833-2800

Carolina Sales Corp.  
110 W. 14th St.  
Greenville  
(919) 752-3143

Dixie News Co.  
2100 Freedom Drive  
Charlotte  
(704) 334-8614

Arthur Fulmer Charlotte  
229 W. Morehead  
Charlotte  
(704) 375-3726

Handleman Company  
2309 Dunavant  
Charlotte 28203  
(704) 372-1845

Mangold Distributing Co.  
2212 W. Morehead St.  
Charlotte  
(704) 334-0866

N. C. Stereo Dist.  
1203 E. Bessemer St.  
Greensboro  
(919) 272-6278

Southeastern Record Merc.  
2706 Freedom Dr.  
Charlotte  
(704) 399-5633

Southern Radio Corporation  
1625 W. Morehead Street  
Charlotte  
(704) 376-4461

## OHIO

Car Stereo Company  
4147 E. Main St.  
Columbus  
(614) 237-0203

Handleman Company  
13900 Broadway  
Garfield Heights 44125  
(216) 587-5550

Main-Line  
1260 E. 38th St.  
Cleveland  
(216) 391-1800

Merrec Distributors  
2800 Euclid Avenue  
Cleveland  
(216) 241-2696

Ohio Appliances Inc.  
7624 Reinhold Dr.  
Cincinnati  
(513) 821-6414

Shuler Distributors, Inc.  
5400 E. 96th St.  
Cleveland  
(216) 475-9700

Superior Tapes & Mobile Supply  
1705 Woodland Ave.  
P. O. Box 19067  
Columbus 43219  
(614) 294-2601

Supreme Distributing Co.  
1000 Broadway at Court  
Cincinnati  
(513) 421-0747

## OKLAHOMA

Communication Electronics Inc.  
4007 N. Pennsylvania  
Okiahoma City  
(405) JA 8-2525

Dulaney's  
100 N.W. 44th St.  
Oklahoma City  
(405) JA 8-0511

Greer Electric Co.  
1018 South Rockford  
Tulsa  
(918) LU 7-3346

Mid Continent News  
125 N.W. 69th St.  
Oklahoma City  
(405) VI 3-9383

Moss Sales Co.  
3902 South Peoria  
Tulsa  
(918) RI 2-3326

The Music Box  
3114 N. Western  
Oklahoma City  
(405) JA 4-2100

Oklahoma News Co.  
909 W. 23rd St.  
Tulsa  
(918) 584-4754

## OREGON

Lou Johnson Co.  
2720 N.W. 29th Avenue  
Portland  
(503) 222-9551

## PENNSYLVANIA

A & L Distributors, Inc.  
S.E. Cor. 30th & Thompson Sts.  
Philadelphia  
(215) PO 5-4300

All Brands, Inc.  
1623 Blvd. of Allies  
Pittsburgh  
(412) 471-6770

Custom Distributors, Inc.  
780 South 52nd Street  
Philadelphia  
(215) GR 6-4046

(Con't on next Page)

Sentry Industries  
2 Keystone Place  
Paramus  
(201) 262-7500

Wellington Eight Industries  
1721 Olden Ave.  
Trenton 08618  
(215) 882-1660



**QUALITY TAPE  
DUPLICATING  
PACKAGING  
SHIPPING**  
on  
**8 TRACK CARTRIDGES  
CASSETTES  
OPEN REEL TAPES**



**CARTRIDGE  
CONTROL  
CORPORATION**  
  
2091 FAULKNER RD., N.E.  
ATLANTA, GEORGIA 30324  
Telephone (404) 633-4577  
  
Bill Evans Genl. Mgr.

In custom  
record pressing  
and tape duplicating

# We Do It All.

Viewlex. A unique nationwide operation that takes you all the way from original recording to shipped product — LP, 45 RPM, cassette or cartridge.

In vast and sophisticated plants and studios operating 24-hours a day, Viewlex —

- Records your artists.
- Masters your acetates and tapes.
- Custom duplicates your cassette and 4 and 8 track tapes.
- Custom molds your 7" and 12" pressings.
- Prints your jacket covers, boxes, record sleeves and label backgrounds.
- Warehouses and drop ships your product.
- Provides fast and complete servicing to D. J.'s and reviewers, and shipments to retailers and distributors.

And it's all done from the Viewlex plant nearest to your outlets — faster service at lowest cost.

One call — and We Do It All.



Executive Offices: Holbrook, N.Y. 11741 / (516) 589-6600

New York Sales Office: 1650 Broadway, New York, N.Y. 10019  
Record Pressing — (212) 581-5641  
Tape Duplicating — (212) 582-4812

#### Nationwide Plants and Offices of the Viewlex Leisure Time Group

##### EAST

A & B DUPLICATORS, LTD.  
635 West 55th Street, New York, N.Y. 10019  
(212-JU6-2780)

ALLENTOWN RECORD COMPANY, INC.  
10th & Walnut Streets, Allentown, Pa. 18102  
(215-433-7405)

ANDREWS-NUNNERY ENVELOPE & PAPER CORP.  
74 Alpha Plaza, Hicksville, N.Y. 11802  
(516-WE1-6500)

BELL SOUND STUDIOS, INC.  
237 W. 54th St., New York, N.Y. 10019  
(212-582-4812)

GLOBE ALBUMS & PRODUCTIONS INC.  
Gilpin Avenue, Hauppauge, N.Y.  
(516-234-1100)

SONIC RECORDING PRODUCTS, INC.  
Broadway Ave., Holbrook, N.Y. 11741  
(516-589-0462)

##### MIDWEST

AMERICAN RECORD PRESSING CO.  
1810 W. King Street, Owosso, Mich. 48867  
(517-725-8176)

BELLE WOOD CORP.  
2751 Lake Cook Road, Deerfield, Ill. 60015  
(312-498-1030)

##### FAR WEST

ELECTRO SOUND, INC.  
725 Kifer Road, Sunnyvale, Calif. 94086  
(408-245-6600)

GLOBE ALBUMS WEST, INC.  
1211 N. Western Ave. Los Angeles, Calif. 90029  
(213-465-5168)

MONARCH RECORD MFG. CO.  
4852 W. Jefferson, Los Angeles, Calif.  
(213-732-6185)

# TAPE DISTRIBUTORS

D & H Distributing Co.  
2525 N. 7th Street  
Harrisburg  
(717) 761-2805

Empire Electronics Distributors  
3361 Old York Road  
Philadelphia  
(215) 223-6633

Hamburg Bros.  
24th St. & Parkside Ave.  
Philadelphia  
(412) 471-0808

Handleman Co.  
1388 Island Ave.  
McKees Rocks 15212  
(412) 331-6972

Merrec Distributors  
8040 Roosevelt Blvd.  
Philadelphia  
(215) 332-6100

Robert Nash  
2780 Limekiln Pike  
North Hills  
(215) 886-6430

Raymond Rosen & Co. Inc.  
51st St. & Parkside Ave.  
Philadelphia  
(215) 878-2200

Jack H. Samuels & Co.  
5117 Baum Blvd.  
Pittsburgh  
(412) 683-8800

Serac — Sears  
4640 Roosevelt Blvd.  
Philadelphia  
(215) 289-9450

Television Parts Co.  
518 Fifth Avenue  
New Brighton  
(412) 846-3000

Warren Radio Inc.  
1313 Peach Street  
Erie  
(814) 454-5285

## RHODE ISLAND

ABC Record & Tape  
725 Branch St.  
Providence 02904  
(401) 351-6700

Beacon Dist.  
775 Branch Ave.  
Providence  
(401) 351-6700

## SOUTH CAROLINA

Brown Sales Co.  
1423 Ellerbe St.  
Columbia  
(803) 787-3401

Hi-Fi Sound Distributing Co.  
621 Harden Street  
Columbia  
(803) 256-3538

## SOUTH DAKOTA

Burghardt Supply, Inc.  
621 - 4th S.E.  
Watertown  
(605) 886-5749

## TENNESSEE

Crosno Stereo  
1481 Airways Blvd.  
Memphis  
(901) 323-1193

Custom Auto  
276 Union Ave.  
Memphis  
(901) 525-1394

Arthur Fulmer Co.  
260 Monroe  
Memphis  
(901) 525-5711

Knox Record Rack  
2000 Western Avenue  
Knoxville  
(615) 525-0445

Mc Clung Appliances Inc.  
310 Georgia St. N.E.  
Knoxville  
(615) 524-1811

Mc Donald Bros. Co., Inc.  
994 So. Bellevue  
Memphis  
(901) 948-2771

Music City Records  
127 Lafayette St.  
Nashville  
(615) 526-5148

Rack Enterprises  
111 W. First St.  
Cookeville  
(615) 526-5148

## TEXAS

ABC Record & Tape  
4841 Top Line Dr.  
Dallas 75247  
(214) 637-4580

Adleta Co., Inc.  
1914 Cedar Springs Ave.  
Dallas  
(214) 741-3152

Allied Recorded Sound  
2704 Polk Street  
Houston 77003  
(713) CA 7-2316

Applebaum Co.  
902 Crawford St.  
Houston  
(713) CA 5-0137

B & K Distributing Co.  
1411 Roundtable Drive  
Dallas  
(214) ME 7-1920

D & M Sales  
811 West Avenue  
San Antonio  
(512) 735-4391

Foley's Dept. Store  
1110 Main St.  
Houston  
(713) 228-3311

Arthur Fulmer  
2516 Hickory  
Dallas  
(214) 421-5357

Gulf Dist.  
2610 Bissonnet  
Houston  
(713) 528-2011

Handleman Company  
2931 Irving Blvd.  
Dallas 75247  
(214) 631-2943

Handleman Co.  
7432 Ardmore St.  
Houston 77021  
(713) 747-0151

Art Jones & Co., Inc.  
4301 Gulf Freeway  
Houston  
(713) 748-6000

Merrec Distributors  
2730 Stemmons Freeway  
Dallas  
(214) 631-3531

National Tape & Record of Texas, Inc.  
(subsidiary of Nat'l Tape Distrib., Inc.)  
5631 Old Clinton Road  
Houston 77020  
(713) 675-7527

Rack Suppliers  
515 Gibson St.  
Seagoville  
(214) AT 7-2570

Record Distributors  
901 Commerce  
Houston  
(713) 227-4221

Record Service  
614 Dennis  
Houston  
(713) 528-5521

Recordland U.S.A., Inc.  
3819 Avenue A  
Lubbock  
(806) SH 7-4443

Rio Radio Supply, Inc.  
608 South Broadway  
McAllen  
(512) MU 6-8622

Sunland Supply Co., Inc.  
2227 Texas Avenue  
El Paso  
(915) 533-5901

Tape City  
3407 Fanin  
Houston  
(713) 526-2636

Texas Tape Cartridge  
725 Great Southwest Pkwy  
Arlington 76010  
(817) 261-3111

Transcontinental Of Dallas  
4845 Cash Road  
Dallas  
(214) ME 7-0552

Western Merchandisers, Inc.  
1601 W. Third Avenue  
Amarillo  
(806) DR 6-6251

## UTAH

ABC Record & Tape  
3575 So. 700 West  
P. O. Box 15607  
So. Salt Lake 84115  
(801) 266-3548

Billinis Distributing Co.  
3575 South 700 West  
Salt Lake City  
(801) 266-3548

Hursh Distributing Company  
2525 South Eighth West  
Salt Lake City  
(801) 486-7611

## VERMONT

St. Johnsbury Record Dist. (rack)  
6 Eastern Ave.  
St. Johnsbury

## VIRGINIA

Best Products Co.  
4909 W. Marshall  
Richmond  
(703) 359-5021

Handleman Co.  
6700 Fleet Dr.  
Alexandria, 22310  
(703) 971-2008

## WASHINGTON

ABC Record & Tape  
729 So. Fidalgo St.  
Seattle  
(206) RO 3-8600

Consolidated Record Distributors  
1000 First Avenue South  
Seattle  
(206) 682-7188

Craig Corporation  
540 S. Front St.  
Seattle 98108  
(206) PA 2-9186

Fidelity Northwest Inc.  
5301 Shilshole Drive N. W.  
Seattle  
(206) SU 4-9100

Transcontinental  
9860 40th Ave. So.  
Seattle 98119  
(206) PA 5-2500

## WISCONSIN

Merrec Distributors  
4558 North 27th St.  
Milwaukee  
(414) 444-2730

Modern Rack Sales, Inc.  
5825 North 96th Street  
Milwaukee  
(414) 462-8030

National Tape Distributors  
(Corporate offices)  
3515 N. 124th St.  
Milwaukee 53005  
(414) 781-2200

National Tape  
530 N. 22nd St.  
Milwaukee 53233  
(414) 342-3188

Rapid Sales Co., Inc.  
1017 Johnathon Drive  
Madison  
(608) 257-3088

Taylor Electric Co.  
4080 N. Port Washington  
Milwaukee  
(414) WO 4-4321

## COMEDY RECORDS!

DOOTO'S LATEST HITS!



**REDD FOXX**

"Jokes I Can't Tell On TV"

**DTL-845**



"Shed House Humor"

**DTL-846**



"Favorite Party Jokes"

**DTL-847**

## RICHARD & WILLIE

"Low Down and Dirty"

**DTL-842**

"Willie and Rising Dick"

**DTL-843**

"The Race Track"

**DTL-848**

## 5 + 1 DEAL

on Entire Catalog

DOOTO RECORDS

13440 S. Central Ave., Compton, Cal.  
(213) 774-0743



Happy Tiger Records  
6565 Sunset Blvd.  
Hollywood, California 90028  
Phone (213) 464-7335

Happy Tiger Records  
708 17th Ave., South  
Nashville, Tennessee  
Phone (615) 244-1108

<b>AORTA</b>	<b>BAKER KNIGHT</b>
<b>COUNT BASIE</b>	<b>MASON PROFFIT</b>
<b>STEVE BOGARD</b>	<b>LEE MEZA</b>
<b>BRAVE BUTTER</b>	<b>JERRY McBEE</b>
<b>DONNIE BROOKS</b>	<b>OBSESSION</b>
<b>DORSEY BURNETTE</b>	<b>CARL PHILLIPS</b>
<b>TRICEY CARTER</b>	<b>DAN PENN</b>
<b>KEN COLEMAN</b>	<b>DON ROBERTSON</b>
<b>HOWARD CROCKETT</b>	<b>SMITHSONIAN INSTITUTE</b>
<b>ECOLOGY</b>	<b>KAY STARR</b>
<b>PAUL KELLY</b>	<b>BOBBIE SYKES</b>
<b>ANITA KERR</b>	<b>THEM</b>
<b>KIMBERLEYS</b>	<b>RED TUCK</b>

### **COME MEET THE TIGERS.**

**ATLANTA**—Southland Distributors  
**BALTIMORE**—Schwartz Brothers  
**BOSTON**—TDC Distributors  
**BUFFALO**—Best Record Dist.  
**CHARLOTTE**—Bertos Sales Corp.  
**CHICAGO**—Summit Distributors  
**CINCINNATI**—Summit Distributors  
**CLEVELAND**—Brothers Record Dist.  
**DALLAS**—Big State Distributors  
**DENVER**—Pan American Records  
**DETROIT**—Jay Kay  
**EAST HARTFORD**—TDC Distributors  
**EL PASO**—Sunland Supply Co.  
**HONOLULU**—Music Craft Ltd.  
**HOUSTON**—Jay Kay Dist.  
**KANSAS CITY, MO.**—Choice Record Dist.

**LOS ANGELES**—Record Merchandising  
**MEMPHIS**—Hotline Distributors  
**MIAMI**—Campus Records  
**MILWAUKEE**—John O'Brien Dist.  
**MINNEAPOLIS**—Heilicher Brothers  
**NASHVILLE**—Music City Record Dist.  
**NEWARK**—Wendy Distributor  
**NEW ORLEANS**—All South Record Dist.  
**NEW YORK**—Empire State Rec. Dist.  
**OKLAHOMA CITY**—B & K Distributors  
**PHILADELPHIA**—Universal Record Dist.  
**PITTSBURGH**—Arc Jay Kay  
**PHOENIX**—Arc Record Dist.  
**SAN FRANCISCO**—TDC Dist.  
**SEATTLE**—Fidelity Northwest Inc.  
**ST. LOUIS**—Roberts Record Dist.

## Custom Tape Duplicators

### ALABAMA

Channel 1 Productions  
1061 Elmira St.  
Mobile, 36604

New London Recording Center  
1817 Oxmoor Rd.  
Birmingham, 35209

### ARIZONA

Audio Recorders of Arizona, Inc.  
3830 N. Seventh St.  
Phoenix, 85014

General Cassette Corp.  
1324 N. 22nd Ave.  
Phoenix, 85009

### ARKANSAS

Jaggars Audio Productions  
1804 S. Johnson St.  
Little Rock, 72204

### CALIFORNIA

Action Recording Co.  
2207 El Camino Real  
San Mateo, 94403

Abbey Tape Duplicators  
737 N. Seward St.  
Hollywood, 90038

Able Turntable & Tape  
6912 Hollywood Blvd.  
Hollywood, 90028

Advance Records  
6376 Yucca St.  
Hollywood, 90028

Alto-Fonic Programming Inc.  
6362 Hollywood Blvd.  
Hollywood, 90028

American Tape Duplicators Inc.  
5727 W. Jefferson Blvd.  
Los Angeles, 90016

Audio Physics, Inc.  
16449 Vanowen St.  
Van Nuys, 91406

Bible Voice Inc.  
PO Box 3521  
Van Nuys, 91406

Brandt's Recording Studios  
1030 48 St.  
Sacramento, 95819

Ted Brinson's Recordings  
1900 Fifth Ave.  
Los Angeles, 90018

Budget Tape Cartridge Mfg. Co.  
2035-37 S. La Brea Ave.  
Los Angeles, 90016

Capitol Records Distributing Corp.  
1750 N. Vine St.  
Hollywood, 90028

Certron Corp.  
1701 S. State College Blvd.  
Anaheim, 92806

Coast Recorders Inc.  
829 Folsom St.  
San Francisco, 94107

Columbia Record Productions  
6430 Sunset Blvd.  
Hollywood, 90028

Communitronics Inc.  
626 S. Hudson Ave.  
Los Angeles, 90005

Creative Sound  
9000 Sunset Blvd.  
Los Angeles, 90069

Custom Fidelity Inc.  
7925 Santa Monica Blvd.  
Hollywood, 90046

Fanfare Recording Studios  
120 E. Main St.  
El Cajon, 92020

Film City Studios  
6087 Sunset Blvd.  
Hollywood, 90028

Gambit Enterprises  
690 Monterey Blvd.  
San Francisco, 94127

Golden State Recorders Inc.  
665 Harrison St.  
San Francisco, 94107

GRT Corp.  
1286 Lawrence Station Rd.  
Sunnyvale, 94086

ID Sound Studios  
1556 N. La Brea Ave.  
Hollywood, 90028

Keyser-Century Corp.  
26000 Springbrook Rd.  
Saugus, 91350

Livingston Audio Products Corp.  
10687 Santa Monica Blvd.  
West Los Angeles, 90025

Location Recording Services  
2201 W. Burbank Blvd.  
Burbank, 91506

Magnetic Tape Engineering Corp.  
8120 Webb Ave.  
North Hollywood, 91605

Make-A-Tape  
131 W. Main St. No. 2  
Los Gatos, 95030

McCune Sound Studios  
915 Howard St.  
San Francisco, 94103

Modern Tape Corp.  
5810 S. Normandie Ave.  
Los Angeles, 90044

Monarch Tape Duplicating  
3416-20 Vineyard Ave.  
Los Angeles, 90016

Newcomb Recording Studio  
4834 Bissell Ave.  
Richmond, 94806

Bill Rase Recording Studio  
2904 Franklin Blvd.  
Sacramento, 95818

RCA Magnetic Pds.  
6363 Sunset Blvd.  
Hollywood, 90028

Radio Recorders  
700 Santa Monica Blvd.  
Hollywood, 90028

Sonic Arts Corp.  
665 Harrison St.  
San Francisco, 94107

Stereo Cartape  
6734 Sunset Blvd.  
Hollywood, 90028

Studio 10  
10 Claude Lane  
San Francisco, 94108

Sunset Sound Recorders  
6650 Sunset Blvd.  
Hollywood, 90028

Superscope Inc.  
8150 Vineland Ave.  
Sun Valley, 91352

Superscope Record Tape  
455 Fox St.  
San Fernando, 91340

TDK Electronics Corp.  
6151 W. Century Blvd.  
Los Angeles, 90045

Telaudio Centre  
9929 Chapman Ave.  
Garden Grove, 92641

Whitney Recording Studio Inc.  
1526 W. Glenoaks Blvd.  
Glendale, 91201

### COLORADO

Fred Arthur Productions  
1218 E. 18 St.  
Denver, 80218

Century Records  
995 S. Clermont  
Denver, 80222

Jackson Sound Productions  
1401-1403 S. Lipan  
Denver, 80223

Summit  
1130 W. Evans  
Denver, 80223

Western Cine Service Inc.  
312 S. Pearl St.  
Denver, 80209

### CONNECTICUT

Cook Labs Inc.  
351 Courtland Ave.  
Stamford, 06906

Infodex Cassette Corp.  
7 Cherry Ave.  
Waterbury, 06702

Sleeping Giant Films Inc.  
3019 Dixwell Ave.  
Hamden, 06518

Sound-Art Studios Inc.  
135 Day St.  
Hartford, 06111

### DELAWARE

Ken-Del Productions Inc.  
111 Valley Rd.  
Richardson Park  
Wilmington, 19804

### DISTRICT OF COLUMBIA

Lion Recording Services Inc.  
1905 Fairview Ave. NE.  
Washington, 20002

Tri Con Productions Inc.  
2741 34 St. NW.  
Washington, 20008

### FLORIDA

Adrian Associates Inc.  
6660 Biscayne Blvd.  
Miami, 33138

All-Purpose Recording Studios  
2223 S. Dale Mabry Hwy.  
Tampa, 33609

Audio Advertising Productions  
790 NE 45 St.  
Fort Lauderdale, 33308

Bee Jay Recording Studios  
Box T.  
Winter Park, 32789

Ben Scott Recording  
6123 SW 68 St.  
South Miami, 33143

Cinemasound Inc.  
1755 NE 149 St.  
Miami, 33161

Criteria Recording Co.  
1755 NE 149 St.  
Miami, 33161

Magnetix Corp.  
770 W. Bay St.  
Winter Garden, 32787

The Smith Studio  
3141 SW 22 Ct.  
Fort Lauderdale, 33312

Tape Duplicators of Florida  
785 W. 83 St.  
Hialeah, 33014

Universal Recording & Distributing Corp.  
170 W. 29 St.  
Hialeah, 33010

Norm Vincent Associates Inc.  
4551 Brown Ave.  
Jacksonville, 32207

Voice Inc.  
5810 W. Flagler St.  
Miami, 33144

### GEORGIA

Cartridge Control Corp.  
2091 Faulkner Rd. NE.  
Atlanta, 30324

Doppler Enterprises Inc.  
3720 Oakcliff Rd. NE  
Atlanta, 30340

Jay-Cher Enterprises  
PO Box 175  
Fairmount, 30139

Kin-Tel Productions & Sound Studios  
1200 Spring St. NW.  
Atlanta, 30309

LeFevre Sound Corp.  
1314 Ellsworth Industrial Dr. NW.  
Atlanta, 30318

Mark Educational Recordings Inc.  
2543 Raintree Dr. NE.  
Atlanta, 30329

Ralph's Radio Music  
PO Box 127  
Demorest, 30535

Recordex Corp.  
3227 Cains Hill Pl.  
Atlanta, 30305

### HAWAII

Commercial Recording Inc.  
333 Cooke St.  
Honolulu, 96813

### ILLINOIS

Agency Recording Studios Inc.  
20 N. Wacker Dr.  
Chicago, 60606

Alteen Recording Studios  
8208 Stony Island  
Chicago, 60617

Ampex Corp.  
2201 Lunt Ave.  
Elk Grove Village, 60007

Balkan Recording Studio  
6917 W. Cermak Rd.  
Berwyn, 60402

Boulevard Recording Studios Inc.  
632 N. Dearborn St.  
Chicago, 60610

Many of the most talented  
Jazz Big Bands, Small Combos  
and Song Stylists in New York  
City are available to you at  
reasonable prices for all oc-  
casions . . .

Night Clubs • School Concerts  
• Dance Halls • House Parties  
• Wedding Receptions • Trade  
Shows and Fund Raising.  
For additional information  
write

**Jazz Spotlight Productions**

152 West 42nd Street,  
New York City, N.Y. 10036  
Suite 536  
Or Call (212) LO 5-3517

(Con't on next Page)



# Ray Stevens has just two words for the Columbia record distributors who helped his first Barnaby single make #1: Thank you.

Because it's you, the unheralded, behind-the-scenes people who make hits possible. And you really outdid yourselves with "Everything Is Beautiful." Number 1 with a bullet after just 9 weeks. And thank you, too, for the same effort behind Ray's first Barnaby album, "Everything Is Beautiful." If the past is any indication, we'll probably have to take another ad in a few weeks to say it all over again for the album. But then, it's such a nice feeling.



Also available on tape.

Z12 35005

On Barnaby  Records

*Custom  
Tape  
Duplicators*

Columbia Recording Productions  
630 N. McClurg Ct.  
Chicago, 60611

Custom Audio-JPL Record Co.  
1088 Sixth Ave.  
Des Plaines, 60016

Double Sixteen Co.  
PO Box 1616  
1028 College Ave.  
Wheaton, 60187

Eight Track Recording Co.  
664 N. Michigan  
Chicago, 60611

International Recording Co.  
1639 W. Evergreen  
Chicago, 60622

Kiderian Records Productions Ltd.  
4926 W. Gunnison St.  
Chicago, 60630

Parliament Studio  
4005-07 W. Washington Blvd.  
Chicago, 60624

Persuasion Systems  
15 E. Pearson St.  
Chicago, 60611

RCA Record Sales Inc. (Mag. Pdts. Div.)  
1 N. Wacker Dr.  
Chicago, 60606

RoFran Enterprises  
117 W. Washington  
Urbana, 61801

Sonic Film Recording Inc.  
1230 W. Washington Blvd.  
Chicago, 60607

Sound Studios Inc.  
230 N. Michigan Ave.  
Chicago, 60601

Streeterville Studios Inc.  
161 E. Grand  
Chicago, 60611

TDK Electronics Corp.  
2906 W. Peterson Ave.  
Chicago, 60645

Ter-Mar Recording Studios  
2030 S. Calumet  
Chicago, 60616

Tono-Tape Inc.  
57 W. Grand Ave.  
Chicago, 60610

Wright Recordings  
6460 N. Claremont  
Chicago, 60645

**INDIANA**

Commercial Features Inc.  
1411 N. Illinois St.  
Indianapolis, 46202

Jones & Associates  
P.O. Box 142  
Dayton, 47941

Ohmit Recording Studio  
6102 E. 10 St.  
Indianapolis, 46219

Bud Pressner Recording Service  
4839 Broadway  
Gary, 46409

Thomas Zoss Productions  
1255 E. Madison  
South Bend, 46624

**IOWA**

Fredio Recording Studios  
2224 E. 12 St.  
Davenport, 52803

Lariam Associations Inc.  
515 28 St.  
Des Moines, 50312

Moss Recording Service  
708 W. Broadway  
Council Bluffs, 51501

**KANSAS**

High Fidelity Recording Inc.  
1059 Porter  
Wichita, 67203

Webb Records  
1234 Luther St.  
Emporia, 66801

**KENTUCKY**

Lemco Sound Studio  
2518 Southview Dr.  
Lexington, 40503

Orbit Radio  
P.O. Box 1644  
Louisville, 40201

Sambo Sound  
9912 Taylorsville Rd.  
Louisville, 40299

**LOUISIANA**

Americana Recording Studios  
707-709 W. California Ave.  
Ruston, 71270

Ron Recordings  
P.O. Box 14602  
Baton Rouge, 70808

Rosemont Recording Studio  
4634 Wilson Ave.  
New Orleans, 70126

**MARYLAND**

Accent Sound Ltd.  
48 W. Biddle St.  
Baltimore, 21201

Bradley Recording Co.  
531 N. Howard St.  
Baltimore, 21201

International Telecomm Inc.  
P.O. Box 405  
Cockeysville, 21031

**MASSACHUSETTS**

Ace Recording Studios Inc.  
1 Boylston Pl.  
Boston, 02116

Audio Sound Services  
104 E. Bloomfield St.  
Rome, 13440

Century Recording  
2 Portland St.  
Holyoke, 01040

Continental Recordings Inc.  
12 Irving St.  
Framingham, 01701

Data Packaging Corp.  
205 Broadway  
Cambridge, 02139

Fleetwood Recording Co. Inc.  
321 Revere St.  
Revere, 02151

Sound by St. James Inc.  
649 Jericho Turnpike  
St. James, L. I., 11780

Universal Recording Studios  
26 Colton Ave.  
West Springfield, 01089

Waverly Recording Studio  
24 Carroll St.  
Watertown, 02172

W G Records  
66 Elmwood Ave.  
Holyoke, 01040

**MICHIGAN**

Adell Corp.  
43700 Adell Blvd.  
Novi, 48050

Barbara Allan Productions Inc.  
P.O. Box 207  
Kalamazoo, 49005

American Sound Corp.  
3319 E. 10 Mile Rd.  
Warren 48091

Artie Fields Productions Inc.  
9430 Woodward Ave.  
Detroit, 48202

Fortune Recording Co.  
3942 Third Ave.  
Detroit, 48201

Haka Productions  
3612 Tecumseh  
Lansing, 48906

P A C-3 Recording Co.  
7106 Greenfield  
Dearborn, 48126

Pioneer Recording Studio Inc.  
20014 James Couzens  
Detroit, 48235

Sound Associations  
3546 Van Buren  
Hudsonville, 49426

Sound Studios Inc.  
2019 Russell  
Dearborn, 48128

Specialty Sounds Inc.  
33515 Kelly Rd.  
Fraser, 48026

Stereodyne Inc.  
2810 Elliott  
Troy, 48084

Tape-Tronncs  
750 Mandoline  
Madison Heights, 48071

United Sound Systems Inc.  
5840 Second Ave.  
Detroit, 48202

**MINNESOTA**

Audiotek Recording Studios  
711 W. Broadway  
Minneapolis, 55411

E M C Corp.  
180 E. Sixth St.  
St. Paul, 55101

Mark Custom Records  
1518 S. Seventh St.  
Moorhead, 56560

Sound 80 Inc.  
4444 W. 76 St.  
Minneapolis, 55435

Universal Audio Corp.  
2541 Nicollet Ave. S.  
Minneapolis, 55404

**MISSISSIPPI**

Triangle Sound Inc.  
1129 S. Green  
Tupelo, 38801

**MISSOURI**

Allied Tape Corp.  
1201 Research Blvd.  
St. Louis, 63132

Bi-Lu Enterprises  
P.O. Box 801  
Springfield, 65801

Cavern Sound Corp.  
16400 E. Truman Rd.  
Independence, 64050

Century Custom Recording Service  
P.O. Box 862  
Springfield, 65801

Fremmerman Recording & Tape Duplicating Co.  
4041 Central  
Kansas City, 64111

Mark Recordings of Missouri  
1220 Jake Ln.  
Columbia, 65201

Stage III Sound Productions  
12 E. 39 St.  
Kansas City, 64111

Technisonic Studios  
1201 S. Brentwood Blvd.  
St. Louis, 63131

**MONTANA**

Valtron Recording Studio  
305 Allen St.  
Helena, 59601

**NEBRASKA**

Liberty Tape Duplicating  
1201 Pacific St.  
Omaha, 68131

Sound Recorders  
206 S. 44 St.  
Omaha, 68131

Williams Recording Service  
2650 N. 48 St.  
Lincoln, 68504

(Con't on next Page)

**UNIVERSAL TAPE CITY**



**IS THE COMPLETE  
TAPE SERVICE!**

**ONE STOPS AND RACKS**

Your Contact: Mr. Bob Perloff  
UNIVERSAL TAPE CITY  
919 N. Broad St., Phila., Pa. 19123  
(215) CE 5-8726 (215) CE 5-2714

Dean Martin

Records  
(Next Release)

***MY WOMAN, MY WOMAN,  
MY WIFE - Reprise***

Motion Pictures Currently in Release:

***AIRPORT - Universal***

Television:

***THE DEAN MARTIN SHOW-NBC-TV***

*Custom  
Tape  
Duplicators*

**NEVADA**

United Recording Corp. of Nevada  
3143 Industrial Rd.  
Las Vegas, 89102

**NEW JERSEY**

Audio Communications Inc.  
Route 10  
Randolph Industrial Park  
Dover, 07081

Fairfield Tape Duplicating/Assembling  
601 Kennedy Blvd.  
North Bergen, 07047

Grandy Inc.  
1275 Bloomfield Ave.  
Fairfield, 07006

H M R Productions  
574 W. Court  
Scotch Plains, 07076

Kimco Tape Accessories  
York House East, 214 W. Main St.  
Moorestown, 08057

Livingston Audio Products Corp.  
1275 Bloomfield Ave.  
Fairfield, 07006

National Tape Service Inc.  
3 Fairfield Crescent  
West Caldwell, 07006

Nemo Recording Laboratories  
382 Taylors Mills Rd.  
Englishtown, 07726

R-C Sound Studios  
50 Plainfield Ave.  
Metuchen, 08840

Realtone Electronics  
34 Exchange Pl.  
Jersey City, 07302

Recorded Publications Laboratories  
1558 Pierce Ave.  
Camden, 08105

Sarex Corp.  
3850 West Side Ave.  
North Bergen, 07041

**NEW MEXICO**

Cee Recording Services  
P.O. Box 8921  
Albuquerque, 87108

**NEW YORK**

A & B Duplicators  
237 W. 54 St.  
New York, 10019

Alcor Inc./Pyramid  
215 S. Tioga St.  
Ithaca, 14850

Allison Audio Productions Inc.  
175 Bridge Rd.  
Hauppauge, 11787

A-1 Sound Studios Inc.  
242 W. 76 St.  
New York, 10024

Artcraft Recording Studios  
285 E. 49 St.  
Brooklyn, 11203

Avery & Elkins Inc.  
653 11 Ave.  
New York, 10036

Cable Machinery Corp.  
156 Fifth Ave.  
New York, 10010

Capitol Records Distributing Corp.  
151 W. 46 St.  
New York, 10036

Cassette-Cartridge Corp.  
220 E. 23 St.  
New York, 10010

Cassette Communications Corp.  
932 Broadway  
New York, 10010

Cassette Data Corp.  
653 11 Ave.  
New York, 10036

Cassette Development Corp.  
653 11 Ave.  
New York, 10036

Cassette Recording Corp.  
41-34 27 St.  
Long Island City, 11101

Cassette/Tech Corp.  
543 W. 43 St.  
New York, 10036

Dick Charles Recording Service Inc.  
729 Seventh Ave.  
New York, 10019

Cine-Vox Studios  
12 E. 41 St.  
New York, 10017

C & M Sound Studios Inc.  
805 18 Ave.  
Nashville, 37203

Columbia Record Productions  
49 E. 52 St.  
New York, 10022

Columbia Record Productions  
804 16 Ave. S.  
Nashville, 37203

Creative Artists  
6 Van Ness Rd.  
Binghamton, 13905

Cue Recordings Inc.  
117 W. 46 St.  
New York 10036

Darvin Studio  
100 St. Marks Pl.  
New York, 10009

D B M Recording Studio Inc.  
1516 Hawkins St.  
Nashville, 37203

Decca Records  
445 Park Ave.  
New York, 10022

De Clercq Studio  
127 Main St.  
Binghamton, 13905

Delta Recording Corp.  
1564 Broadway  
New York, 10036

Direct Recordings Inc.  
18 E. 50 St.  
New York 10022

Dubbings Electronics Inc.  
1305 S. Strong Ave.  
Copiague, L.I., 11726

Fine Recording Inc.  
118 W. 57 St.  
New York, 10019

G & G Recording Service  
12 Lake Rd.  
Peekskill, 10566

Globe Recording Studio Inc.  
420-A Broadway  
Nashville, 37203

Gotham Recording Corp.  
2 W. 46 St.  
New York, 10036

International Recording Co.  
49 Desmond Ave.  
Bronxville, 10708

Metra Electronics Corp.  
660 McDonald Ave.  
Brooklyn, 11218

Olmsted Sound Studios Inc.  
80 W. 40 St.  
New York, 10018

Philips Recording Co. Inc.  
609 Fifth Ave.  
New York, 10017

Posthorn Recordings  
185 Ave. C.  
New York, 10009

Preferred Sounds, Inc.  
Nursery Lane  
Rye, N.Y., 10580

Queen of Sound  
1314 Pine St.  
Nashville, 37203

Radiant Cassette/Cartridge Corp.  
250 W. 57 St.  
New York, 10019

R C A Records Recording Studio  
110 W. 44 St.  
New York, 10036

Richcraft Recording Co.  
1706 Flatbush Ave.  
Brooklyn, 11210

Select Sound Studio Inc.  
1790 Broadway  
New York, 10019

Sound Center Inc.  
750 Eighth Ave.  
New York, 10010

Stereo Sound Studios  
238 E. 26 St.  
New York, 10010

T D K Electronics Corp.  
23-73 48 St.  
Long Island City, 11103

Tucker Productions Ltd.  
853 Seventh Ave.  
New York, 10019

Variety Recording Studio  
130 W. 42 St.  
New York, 10036

Deryck Waring Recordings Inc.  
25 W. 43 St.  
New York, 10036

**NORTH CAROLINA**

Arthur Smith Studio  
5457 Old Monroe Rd.  
Charlotte, 28212

Audiofonics  
15 W. Lenoir St.  
Raleigh, 27602

Crescent-City Sound Studios Inc.  
1061 Gatewood Ave.  
Greensboro, 27405

**OHIO**

Agency Recording Studios Inc.  
1730 E. 24 St.  
Cleveland 44114

Alcon Recording Studios Inc.  
4435 Mayfield Rd.  
Cleveland, 44121

Artist Recording & Record Pressing Inc.  
320 Mill St.  
Cincinnati, 45215

Associated Industries Inc.  
2150 Hamilton Ave.  
Cleveland, 44114

Boddie Recording Studio-Lab  
12202 Union Ave.  
Cleveland, 44105

Cleveland Recording  
1515 Euclid Ave.  
Cleveland, 44115

Courier-Empire Recording Enterprise  
414 Croghan St.  
Fremont, 43420

Dynaphonics Inc.  
2975 Far Hills Ave.  
Dayton, 45419

Harmonic Sounds Inc.  
1482 Felix Dr.  
Columbus, 43207

Magnetic Studios Corp.  
1670 W. First Ave.  
Columbus, 43212

Qualitapes Inc.  
Penthouse East, Terminal Tower  
Cleveland, 44113

Queen City Album Inc.  
2832 Spring Grove Ave.  
Cincinnati, 46225

Szappanos Recordings  
11705 Buckeye Rd.  
Cleveland, 44120

**OKLAHOMA**

Benson Sound Studio  
3707 S. Blackwelder Ave.  
Oklahoma City, 73119

Century Recordings  
1220 NW 39  
Oklahoma City, 73118

Derrick Recording Studios  
1448-52 N. Harvard  
Tulsa, 74110

**OREGON**

Rex Recording Co.  
931 SW King Ave.  
Portland, 97203

**PENNSYLVANIA**

Air-Tone Sound & Recording Co.  
2330 Market St.  
Philadelphia, 19103

Baldwin Sound Productions Inc.  
5252 Trindle Rd.  
Mechanicsburg, 19046

Dee-Bee Recording Service  
S. Camp St. Extension  
Windsor, 17366

Diskmakers Inc.  
925 N. Third St.  
Philadelphia, 19123

(Cont. on Page 203)

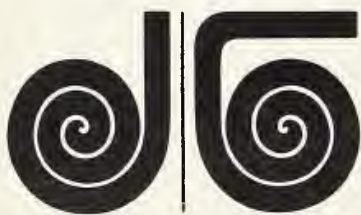

**JAMIE  
RECORDS**

TOP  
& BOTTOM  
RECORDS

*Phil-L.A.  
of SOUL  
RECORDS*

ARCTIC  
RECORDS

Jamie/Guyden  
DISTRIBUTING CORP.

919 N. BROAD ST., PHILA., PA. 19123  
(215) CE 2-8383



# JANUS

A Contemporary Legend Come to Life



JEFFERSON  
THE FLYING MACHINE  
OWEN B.  
MUNGO JERRY  
PICKETTYWITCH  
ILLUSTRATION  
FUNKADELIC\*



When we began just a little less than a year ago we promised you the sort of sounds that would stir an industry and create a contemporary legend. Thanks to your continued support that promise has been fulfilled. At Janus the vision is now reality . . . so on we go with more chart action.

\*On Westbound Records  
Distributed by Janus Records

JANUS

JANUS RECORD CORPORATION  
An Affiliate of GRT Corporation  
1700 Broadway, New York, New York 10019

RECORDS

## Record Pressers

Allentown Record Co., Inc.  
10th & Walnut Sts.  
Allentown, Pa.

Allied Record Mfg. Co.  
2437 E. 57th St.  
Hollywood, Calif. 90058

Amer. Record Pressing  
1810 W. King St., Owosso, Mich.

A-N-L Recording Corp.  
4465 North Lincoln Ave.  
Chicago 25, Illinois

Archer Record Pressing  
6552 E. Davison  
Detroit, Mich. 48212

Arrown Record Mfg. Co.  
5212 East 14th St.  
Oakland, California

Artrec Productions Ltd.  
1688 Meridian Ave.  
Miami Beach, Fla. 33139

Audiofax  
821 19th Ave. S.  
Nashville, Tenn.

Banaba Music Co.  
2452-6 South Kedzie  
Chicago 23, Ill.

Bard Record Co.  
66 Mechanic St.  
New Rochelle, N.Y.

Barnaby's Madness Inc.  
756 E. 9th St.  
New York, N.Y.

Betancourt Ent.  
119 S. Sam Houston Blvd.  
San Benito, Texas 78586

Bestway  
Globe Ave.  
Mountainside, N.J.

John Brumage  
P.O. Box 14422  
Tampa, Fla. 33609

Cadet Record Pressing Co.  
146 W. 37th Pl.  
Los Angeles, Calif.

Capitol Custom  
151 West 46th St.  
New York, N.Y.

Capitol Custom  
3061 Fletcher Dr.  
Hollywood, Calif.

Capitol Custom  
300 Brook St.  
Scranton, Pa.

Capitol Custom  
1 Capitol Way or Box 385  
Jacksonville, Ill.

Carter Wright Ent.  
6533 Hollywood Blvd.  
Hollywood, Calif. 90028

Cavendish Record Mfg. Co.  
5810 South Normandie  
Los Angeles, Calif.

Century Record Mfg. Co.  
Poly Laboratories, P.O. Box 30  
Saugus, California

Clarion Record Mfg. Co. Inc.  
1021 Ridge Ave.  
Philadelphia 23, Pa.

Clark Phonograph Record  
718 Wilhelm  
Harrison, N.J.

Coast Record Mfg. Co., Inc.  
2846 W. Pico Blvd.  
Los Angeles, Calif.

Columbia Record Prod. (Tape  
Duplicator)  
51 W. 52 St.  
New York, N.Y. 10022

Columbia Record Prod. & Tape  
Duplicator  
630 N. McClure St.  
Chicago, Ill. 60611

Columbia Custom & Tape  
Duplicator  
2990 West Grand Blvd.  
Detroit, Mich. 48202

Columbia Prod. & Tape  
Duplicator  
804 16th Ave.  
Nashville, Tenn. 37203

Columbia Record Prod. & Tape  
Duplicator  
6121 Sunset Blvd.  
Hollywood, Calif. 90028

Columbia Records  
Pitman Plant  
Lambs and Woodbury Rds.  
Pitman, N.J. 08071

Columbia Records  
Santa Maria Plant  
900 E. Stowell Rd.  
Santa Maria, Calif. 93454

Columbia Records  
Terre Haute Plant  
1400 Fruitridge Ave.  
Terre Haute, Ind. 47805

Magnetic Tape Duplicators  
7925 Santa Monica  
Hollywood, Calif. 90046

Mecca Records  
920 3rd Ave., Seattle 4, Wash.

Mercury Records  
35 E. Wacker Drive  
Chicago, Ill.

Miami Pressers  
2819 N.W. 7th Ave.  
Miami 37, Fla.

Midwest Record Pressing  
320 E. 21st St.  
Chicago, Ill.

Compo Company Ltd.  
2377 Remembrance St.  
Lachine, Quebec, Canada

Compo Records (Ontario) (Ltd.)  
3400 Montreal Rd.  
Cornwall, Ontario, Canada

Cook & Associates  
5905 W. Slauson Ave.  
Los Angeles, Calif.

Creative Sound Productions  
9000 Sunset Blvd.  
Los Angeles, Calif. 90069

Crown Records  
9317 W. Washington, Blvd.  
Culver City, Calif.

Crown Records—East  
P.O. Box 176  
Park Ridge, N.J. 07656

Customatrix (Columbia)  
Lambs Rd. & Woodbury Rd.  
Pitman, N.J. 08071

Customatrix (Columbia)  
1400 N. Fruitridge Ave.  
Terre Haute 14, Ind.

Customatrix (Columbia)  
900 E. Stowell Rd.  
Santa Maria, Calif. 93454

Decca Manufacturing  
Div. of Decca Distributing  
Route 30A  
Gloversville, New York 12078

Decca Manufacturing  
Div. of Decca Distributing  
Pickneyville, Ill. 62274

Diskmakers, Inc.  
925 N. Third St.  
Philadelphia, Pa. 19125

Dunn Record Pressing Co.  
4756 S. Cottage Grove Ave.  
Chicago, Illinois

Dynamic LP Stereo  
900 Passiac Ave.  
East Newark, N.J.

Gauss Electrophysics  
1850 Westwood Blvd.  
West Los Angeles, Calif.

Gem Custom  
(Formerly Royal Plastics)  
1540 Brewster Ave.  
Cincinnati, Ohio

Gospel Recordings, Inc.  
146 Glendale  
Los Angeles, Calif.

(Con't on next Page)



**OUR SPECIALTY: CUSTOM PRESSING . . .  
FROM TAPE TO COMPLETED PRODUCT . . .  
LABELS . . . DROP SHIPPING . . . WAREHOUSING  
COMPLETE PRINTING AND FABRICATING FACILITIES**

**NO ONE CAN EQUAL OUR SERVICE FOR THE SOUTH**

**SOUTHERN PLASTICS, INC.**

453 CHESTNUT STREET, NASHVILLE, TENNESSEE (615) 244-1293



**THE SHELBY SINGLETON CORPORATION**  
NASHVILLE, TENNESSEE U. S. A.

# SPECIALTY

FOR

**PERSONALIZED  
SERVICE**

PLUS

**QUALITY**

COMPRESSION MOLDERS OF  
45, 7" LP, 10" LP, 12" LP, ALL SPEEDS  
TAPE TO RECORD

Phone: (717) 489-4717

TWX: (510) 656-3649

**SPECIALTY RECORDS CORPORATION**



FABRICATORS OF

*Phonograph Records*

210 NORTH VALLEY AVENUE  
OLYPHANT, PENNA. 18447

*Record  
Pressers*

GRT (General Recorded Tape)  
1262 Lawrence Station  
Sunnyvale, Calif.

Hodge Record Mfg. Co.  
3208-16 So. 84th St.  
Philadelphia, Pa.

Houston Record Company  
3318 Jensen Drive  
Houston, Texas

Ideal Recording Co.  
P.O. Box 861  
San Benito, Texas

International Tape Cartridge  
663 Fifth Ave.  
New York, N.Y.

Jay Jay Record Company  
2456 South Kedzie  
Chicago, Illinois

J. B. Research & Development  
1117 East Redondo Blvd.  
Inglewood, Calif.

Korelich Engineering Mfg. Co.  
1141 N. Highland  
Los Angeles, Calif.

Kay Records, Inc.  
110 Bergen Pike, Little Ferry, N.J.

Kay Bank Recording  
2541 Nicollet Ave., Minn., Min.

King Records  
1540 Brewster Ave.  
Cincinnati, Ohio

Kiski Recording Co.  
Box 116  
North Apollo, Pa.

James J. Lee Record Processing  
9040 Culver Blvd.  
Culver City, Calif.

Lewis Record Mfg. Co.  
307 East Beach Ave.  
Inglewood 3, Calif.

Liberty Tape Duplicating  
1201 Pacific St.  
Omaha, Neb.

Longmark  
P.O. Box 116  
N.Y. Mills, N.Y.

MGM Records  
120 Arlington Ave.  
Bloomfield, N.J.

C. P. MacGregor  
729 S. Western  
Los Angeles, Calif.

Magnetic Stereo Cartridge  
1604 W. 139th St.  
Gardena, Calif.

Miller International Co.  
P.O. Box 45  
Swarthmore, Pa.

Minato Record Pressing Co.  
2667 Long Beach Ave.  
Los Angeles 58, Calif.

Mission Aids, Inc.  
100 East Montecito  
Sierra Madra, Calif.

(Con't on next Page)

**NOBODY  
CAN MATCH  
BESTWAY'S  
SERVICE**

BESTWAY feels that a promise is something special and has to be kept.

Maybe that's what accounts for our reputation.  
BESTWAY DELIVERS WHAT YOU WANT . . .  
WHEN YOU WANT IT (if not sooner)

*Specializing in:*

**CUSTOM PRESSING . . .  
FROM PLATE TO COMPLETED PRODUCT . . .  
LABELS . . . WAREHOUSING . . .  
DROP SHIPPING . . .**

**BESTWAY PRODUCTS**

MOUNTAINSIDE, NEW JERSEY (201) ADAMS 2-8383



CD JUN 8 PM 4 30

MR MARTY OSTROW VICE PRESIDENT CASHBOX NEWYORK

THE CASH BOX PUBLISHING CO INC  
1780 BWAY

LARRY PAGE PAGE INTERNATIONAL RECORDS LIMITED 4 TILNEY STREET

MAYFAIR LONDON W1 TELEPHONE NUMBER 4938873 TELEX NUMBER 25238

SORRY COULD NOT GET TOGETHER IN NEWYORK RE AD FOR DIRECTORY

BUT HAD TO MAKE EMERGENCY TRIP TO NASHVILLE STOP

SUGGEST JUST PRINT FACTS ABOUT PENNY FARTHING STOP FORMED 7

MONTHS IN UK STOP 3 CHART ENTRIES STOP ARTISTS INCLUDE LINCOLN

BLACK COMMA SHOCKING BLUE COMMA JUDD COMMA LARRY PAGE ORCH COMMA

SAMANTHA JONES COMMA GEORGE BAKER SELECTION COMMA STAMFORD BRIDGE

COMMA JOE BROWN COMMA OCTOPUS AND SENSATIONAL NEW GIRL SINGER

NIA HUGHES STOP PENNY FARTHING LABEL NOW DISTRIBUTED ALL TERRITORIES

EXCEPTION OF USA CANADA JAPAN STOP TOP 10 RECORDS IN 17 COUNTRIES

STOP 5 NUMBER 1'S STOP

PAGE FULL OF HITS LIMITED ARE PUBLISHING COMPANY HEADED BY TERRY

NOON HAVING FANTASTIC SUCCESS WITH RECORDINGS BY TOM JONES COMMA

HONEYBUS COMMA CHOCKING BLUE COMMA AL MARTINO COMMA GEORGE BAKER

SELECTION COMMA THE FORTUNES AND THE JAMES LAST ORCH AND ANYBODY

WITH GOOD TASTE STOP

TO SUM IT UP THIS IS ONE HELL OF A SWINGING COMPANY ALWAYS ON THE

LOOK OUT FOR GREAT PRODUCT AND ARTISTS STOP

SEE YOU SOON

LARRY PAGE

P.S. NICE TO SEE VANITY FARE DOING SO WELL

Via WUI Via WUI Via WUI Via WUI Via WUI Via WUI Via WUI Via WUI Via WUI Via WUI

*everything*  
**under 1 roof**  
*for pressing and  
 jacket service*

Get up-to-the-minute quality while you save money and time because everything is under one roof. Pay only one cost—we handle all your problems.



**STEREO MASTERING**  
**HIGH SPEED PLATING**  
**7" & 12" PRESSING**  
**CUSTOM JACKETS**  
**STOCK JACKETS**  
**TAPE CARTRIDGES**

2, 4 and 8 track recordings available at affiliated recording studios in most major cities.

**Write for information and prices.**  
 Studio distributorships available.



**QUEEN CITY ALBUM INC.**

**Home Office & Plant**  
**2832 Spring Grove Ave.**  
**Cincinnati, Ohio 45225**  
**(513) 681 - 8400**

**Nashville Sales Office**  
**Dave Mathes**  
**P. O. Box 653**  
**Nashville, Tenn. 37202**

*Record  
 Pressers*

Monarch  
 4852 W. Jefferson Blvd.  
 Los Angeles, Calif.

Muntz Stereo Pak  
 7715 Densmore  
 Van Nuys, Calif.

Musical Products Company  
 561 West 16th St.  
 Chicago 16, Illinois

National Recording  
 2871 E. Ponce De Leon  
 De Catur, Ga.

Norman Record Pressing  
 1486 N. Fair Oaks  
 Pasadena, Calif.

Oasis Record Pressing Co.  
 275 South 2nd St.  
 Brooklyn, N.Y. 11211

Parliment Records  
 Box 341-A, RD2  
 Parkesbury, Pa.

Paramount Record Mfg. Co.  
 1314 S. Howard St.  
 Philadelphia, Pa.

Peacock Records  
 2809 Erastus St.  
 Houston, Texas

Peerless Record Corp.  
 2820 W. Pico  
 Los Angeles, Calif.

Phono Record  
 91 1st St.  
 Gretna, La.

Plastic Products  
 1746 Chelsea Ave.  
 Memphis, Tenn.

Plastylite Corp.  
 333 North Drive  
 North Plainfield, N.J.

Platinum Records, Inc.  
 1688 Meridian Ave.  
 Miami Beach, Fla. 33139

Praise  
 Dept. C  
 Stonebore, Pa. 16153

Premier Albums of N.J.  
 140 Delawanna Ave.  
 Clifton, N.J.

Presswell Records, Inc.  
 White Horse Pike & Bates Mill Road  
 Anchora, N.J.

Purdy Records  
 1721 Broadway  
 New York 19, N.Y.

Rainbow Record Mfg. Corp.  
 1041 N. Las Palmas  
 Hollywood, Calif.

Raleigh Records, Inc.  
 881-7th Ave.  
 New York, N.Y.

RCA Custom Record Sales  
 6363 Sunset Blvd.  
 Hollywood, Calif. 90028  
 (213) 461-9171

RCA Custom Records Sales  
 1 N. Wacker Drive  
 Chicago, Ill. 60606  
 (312) 944-3215

RCA Custom Records Sales  
 1133 Ave. of Americas  
 New York, N.Y. 10036  
 (212) 586-3000

RCA Victor  
 6363 Sunset Blvd.  
 Hollywood 28, Calif. 90028  
 (213) 461-9171

RCA Custom Record Sales  
 800-17th Ave. South  
 Nashville, Tenn. 37203  
 (615) 255-5781

Rec-O-Press  
 609 Great Southwest Parkway  
 P.O. Box 1304  
 Arlington, Texas 76010

Record Broadcast  
 237 S. Bent Ave.  
 San Marcos, Calif.

Record Pressing  
 145 West 154th St.  
 Gardena, Calif.

Recordings, Inc.  
 1130 E. Cold Spring La.  
 Baltimore, Md.

Research Craft Company  
 1011 North Fuller Ave.  
 Los Angeles 46, Calif.

Rite Records  
 3930 Spring Grove Ave.  
 Cincinnati 23, Ohio

Romaba Records Co.  
 33 Thirty Fourth St.  
 Brooklyn, N.Y.

R.P.I.  
 151 W. 154th St.  
 Gardena, Calif.

S. F. Record Mfg. & Matrix Co.  
 1038 Taraval St.  
 San Francisco 16, Calif.

S & R Record Mfg. Co.  
 16508 So. Main St.  
 Gardena, Calif.

San Marcos Record Company  
 1149 J Bent Ave.  
 P.O. Box 278  
 San Marcos, Calif.

Shelly Products  
 220 Broadway  
 Huntington Station, L.I., N.Y.



The New PHILIPS Company/The New PHILIPS Concept  
**FULL LINE CUSTOM SERVICE**

MASTERING — PLATING — PRESSING — SEPARATING — COVER + LINER PRINTING  
 JACKET FABRICATING — TAPE DUPLICATING — WAREHOUSING



**PHILIPS RECORDING COMPANY, INC.**  
 609 FIFTH AVENUE, NEW YORK, N. Y. 10017 PHONE 212 486-9614

A NORTH AMERICAN PHILIPS COMPANY

(Con't on next Page)

johnny rivers



IMPERIAL

Liberty/UA, Inc.   
An Entertainment Service of  
Transamerica Corporation

# WAKEFIELD MANUFACTURING, INC.

★  
PRECISION  
PRODUCT

★  
RAPID SERVICE

★  
COMPETITIVE  
PRICES



## Congratulations CASH BOX

*Where Independents  
Meet Independents*

**For Continuing Success, Press  
With Your Independent Pressing Plant**

# MONARCH

RECORD MFG. CO.

 **iewlex Inc.** An Affiliate of the Viewlex Leisure Time Group

4852 W. Jefferson Blvd., Los Angeles, Calif. 90016  
(213) RE 2-6185



**OUR SERVICE IS  
THE FINEST  
AND INCLUDES...**

- PRESSING
- LABELS
- MASTERING
- WAREHOUSING
- DROP SHIPPING

*Ideally located to serve the Midwest, South and Southwest*

**PLASTIC PRODUCTS**  
COMPANY  
*Manufacturers of Plastic Products*

1746 Chelsea Ave. Memphis 7, Tennessee

(901) — 526-3502

## Record Pressers

Silver Park Records  
286 Kinderkermack Road  
Riveredge, N.J.

Silver Plastics  
Southampton Industrial Highway  
Southampton, Pa.

Sonic Recording  
27 Ludy St.  
Hicksville, L.I., N.Y.

South of Nashville  
160 2nd Ave., So.  
Nashville, Tenn.

Southern Plastics  
453 Chestnut St.  
Nashville, Tenn.

Sparton of Canada, Ltd.,  
London, Ontario, Canada

Specialty Records  
210 North Valley Ave.  
Olyphant, Pa. 18447

Standard  
415 Fourth Ave. S.  
Nashville, Tenn.

Starday Records  
1248 S. Berendo St.  
Los Angeles, Calif.

Sun Plastics  
900 Passaic Ave.  
East Newark, N.J.

Superior Plastics  
748 Camp St.  
New Orleans, La. 70130

Superior Recordings Co., Inc.  
1023 North LaBrea  
Hollywood, Calif.

Tanner "N" Texas, Inc.  
1422 W. Popular St.  
San Antonio, Texas

Todd-Ao  
1021 No Seward  
Hollywood, Calif.

Tops Records  
5810 S. Normandie  
Los Angeles, Calif.

Trend Custom Records  
575 Cherokee  
Smyrna, Ga. 30080

Union City Plastics  
716-22nd St.  
Union City, N.J.

United Recorders  
535 No. Fairfax  
Los Angeles, Calif.

H. V. Waddell  
231 W. Olive  
Burbank, Calif.

Wakefield  
1836 West Moreland  
P.O. Box 6037  
Phoenix, Ariz.

Western Custom  
16909 So. Broadway  
Gardena, Calif.

Wildcat Records, Inc.  
P.O. Box 207  
San Antonio, Texas

Windsor Records  
830 River Drive  
Garfield, N.J.

XERB Radio & XEG Radio  
737 3rd Ave. Keystone Bldg.  
Chula Vista, Calif. 92010

## MACHINE SHOPS

### CALIFORNIA

Alco Research & Eng.  
6201 Santa Monica Blvd.  
Hollywood, Calif. 90038

Aragon Prods.  
639 Island View Dr.  
Santa Barbara, Calif. 93105

Finebilt Mfg.  
931 N. Citrus Ave.  
Hollywood, Calif. 90038

Johnson Machine & Tool  
1722 W. 134 St.  
Gardena, Calif. 90242

Maple Clamp Corp.  
1023 W. First St.  
Hollywood, Calif. 90012

### CONNECTICUT

Hamilton Mfg.  
510 First Ave.  
West Haven, Conn. 06516

### MINNESOTA

Universal Audio Recording Equip.  
2541 Nicollet Ave.  
Minneapolis, Minn. 55404

### NEW JERSEY

Aragon Products  
72 Concord St.  
Newark, N.J. 07114

Schiff Machine  
28 E. Hanover Ave.  
Morris Plains, N.J. 07950

Standard Tool & Mfg.  
738 Schuyler  
Lyndhurst, N.J. 07071

### NEW YORK

Audiomatic Corp.  
915 Westchester Ave.  
Bronx, N.Y. 10459

### OHIO

King Custom Rec. Service  
1540 Brewster Ave.  
Cincinnati, Ohio 45207

Complete Facilities for:  
**LABELS — PRESSING — MATRIX**

• since 1942 •

## ALCO RESEARCH & ENGINEERING, INC.

6201 Santa Monica Blvd.  
Hollywood, Calif. 90038

for prompt service phone General Manager  
Jim Stevenson at 213-466-1101

# Book KING

Management/Direction

**SIDNEY A. SEIDENBERG INC.**



1414 Avenue of the Americas  
New York, New York 10019  
Telephone: (212) 421-2021

Booked by:

**Associated Booking Corp.**

445 Park Avenue  
New York, New York 10022  
Telephone: (212) 421-5200

Recording  
Exclusively for



*Record  
Promotion  
&  
Publicity  
Offices*

**BUFFALO**

Jerry Meyers (Pr.)  
875 Main St.  
(716) 883-1872

**CHICAGO**

Bedno-Wright Associates  
166 E. Superior St.  
Chicago, Ill. 60611  
(312) 664-6054

Exposure, Inc.  
221 North LaSalle Street  
(312) 346-7660

Paul Gallis  
325 Hollyhock Lane  
Prospect Heights, Ill. 60070  
(312) 664-1300

Earl Glickin  
1770 Winthrop Rd.  
Highland Park  
(312) ID 3-1771

Wm. Johnson Promotion  
8140 So. Morgan  
(312) 846-0276

K.A.T. Enterprises  
866 No. Wabash Ave.  
(312) 644-8272

Jack McGuire & Associates Inc.  
20 N. Wacker Drive  
Chicago, Ill.  
(312) ST 2-0706

**CINCINNATI**

Mainline Cleveland, Inc.  
Julie Godsey  
265 Jupiter Dr. 45238  
(513) 921-8722

**CLEVELAND**

Perry Stevens  
2208 Edgerton Rd.  
University Hts.  
(216) 321-0641

**DETROIT**

Sammy Kaplan  
20211 Greenfield Rd.

Mike Quatro, Inc.  
18431 Mack Avenue  
(313) 886-3362

Al Valente  
13400 Fenkell Ave.  
(313) 835-4831

**LOS ANGELES**

Bob Abrams and Associates  
6430 Sunset Blve.  
(213) 461-4393

Allan Ingersoll & Weber  
1901 Ave of the Stars  
Suite 680, Century City  
(213) 277-3200

Jay Bernstein  
9110 Sunset  
(213) 274-7656

Russell Birdwell  
9250 Wilshire  
(213) CR 3-3414

Bizarre, Inc.  
Suite 1713  
5455 Wilshire Blvd.  
(213) 933-5966

Henri Bollinger  
1735 No. Vine  
Hollywood  
(213) 466-9542

Mike Borchetta (Promo)  
1610 N. Argyle  
(213) HO 6-7363

Braverman-Mirisch  
9255 Sunset  
(213) 272-8608

Arnold Carr  
155 No. La Peer.  
(213) 278-5600

Contemporary PR  
9124 Sunset  
(213) 273-8430

Paul Cooper Enterprises  
8660 Wilshire Blvd.  
(213) 657-4040

Roy Cummings  
8967 Vista Grande  
(213) 276-4338

Fields Unlimited  
Barney Fields  
22424 De Grasse Dr.  
Woodland Hills  
(213) 883-6183

Jim Flood & Assoc.  
9110 Sunset  
(213) 274-0281

Jack Fogarty & Assoc.  
11670 Sunset  
(213) 766-8141

Freeman-Gordon-Best  
6565 Sunset  
(213) HO 2-2395

The Garrett Company  
8730 Sunset Blvd.  
657-1801

Tim Gayle  
6376 UYucca St.  
(213) 463-2151

Gershenson & Dinglian Assoc.  
120 El Camino Dr.  
Suite 206  
(213) 278-2343

Gershman, Swaney & Gibson  
6671 Sunset  
(213) HO 5-4131

The Goodman Organization  
1800 No. Highland Ave.  
(213) HO 6-5221

Hanson & Schwam  
9225 Sunset  
(213) 278-1255

Jack J. Heeger  
1633 Westwood Blvd.  
GR7-1548

Hoffman, Paladino & Landia  
9000 Sunset  
Suite 307  
(213) CR 8-0024

George Jay  
6290 Sunset  
(213) HO 9-5838

Ray Lawrence  
9255 Sunset  
(213) LA 9-0069

Frank Liberman & Assoc.  
9255 Sunset  
(213) 278-1993

Litrov/Levinson  
9171 Wilshire  
Suite 540  
(213) 274-7855

Peggy McNaught  
170 N. Robertson Blvd.  
Beverly Hills  
(213) 657-8660

Jim Mahoney & Assoc.  
120 El Camino  
Beverly Hills  
(213) CR 4-8867

Mann Scharf & Co.  
9056 Santa Monica  
(213) CR 4-6222

Mike Merrick Co.  
9000 Sunset Blvd.  
(213) 278-1211

MSEI (McFadden, Strauss,  
Eddy & Irwin)  
1017 N. LaCienega  
(213) OL 7-4330

Jerry Pam & Assoc.  
9255 Sunset  
(213) CR 1-5633

Don Perry Enterprises  
6430 Sunset Blvd.  
461-4664

Jean Pettebone  
1301 No. Orange Grove  
(213) 876-4163

Charles Pomerantz  
15300 Ventura,  
Sherman Oaks  
(213) 872-0080

Promo Productions  
10643 Somma Way  
(213) GR 2-1067

**ARIZONA**

Walsh & Associates  
1830 W. Sunnyslope Lane  
Phoenix 85021  
943-1287, 277-8746

**BOSTON**

Music Promotions  
909 Beacon St.  
(617) 267-6176  
Danny Lipman  
Ed Penny  
645 Beacon St.  
(617) 266-0060

Turner Associates  
156 State Street  
(617) 742-3895



richard gersh associates, inc.

*Public Relations*

200 west 57th street, new york, n. y. 10019

pl 7-1101 affiliates: los angeles - london



public relations

bob abrams and associates

6430 sunset blvd. • los angeles, calif.

(213) 461-4393

(Con't. on next page)



**INTERNATIONAL FAMOUS AGENCY, INC.**

LOS ANGELES · NEW YORK · CHICAGO · LONDON · PARIS · ROME  
A SUBSIDIARY OF MARVIN JOSEPHSON ASSOCIATES, INC.

*Record  
Promotion  
&  
Publicity  
Offices*

R.A.H. Enterprises, Inc.  
Pharaoh Productions  
3105 South St.  
Suite 9  
Long Beach 90805

Tony Richland (Promo)  
1680 Vine St.  
(213) HO 7-2151

Roberts & Assoc.  
9887 Santa Monica  
Beverly Hills  
(213) 274-8691

Charlotte Rogers  
7000 Hollywood Blvd.

Rogers, Cowan & Brenner  
250 No. Canon Dr.  
Beverly Hills  
(213) CR 5-4581

Glenn Rose  
8440 Sunset  
(213) 654-3800

George Russell  
1308 N. Martel  
(213) PO 6-7161

Lenny Salamone (Promo)  
24320 Calvert St.  
(213) HO 6-4106

Chief Samuelson & Assoc.  
1800 No. Highland Ave.  
(213) 466-6106

Dennis F. Shanahan & Assoc.  
451 N. Canon  
Beverly Hills  
(213) 273-5011

Edward Shaw & Assoc.  
9887 Santa Monica  
Beverly Hills  
(213) 274-8307

Gene Shefrin & Assoc.  
812 S. Robertson  
(213) 657-2270

The Sherman Co.  
1040 No. Las Palmas  
Hollywood  
(213) HO 9-9011

Joseph Siegman  
9255 Sunset  
(213) 276-1014

Solters & Sabinson  
9255 Sunset  
(213) 275-5303

John Springer & Assoc.  
1901 Ave. of the Stars  
Suite 580  
(213) 277-3744

Fred Stuart Assoc.  
9126 Sunset  
(213) 274-0674

Sutton Public Relations Co.  
359 No. Canon Drive  
Beverly Hills  
(213) CR 8-3081

Ron Tepper & Assoc.  
8961 Sunset Blvd.  
274-8569

## MIAMI

Everett A. Clay & Associates  
5518 S.W. Eighth Street  
Coral Gables, Florida 33134

Garry Stites  
P.O. Box 831  
Hialeah, Fla.  
(305) 691-0340

Middlesboro, Ky.  
Mid South Promotion Co.  
Box 57  
(606) 248-5636

Cooper-Strock-Scannell  
208 E. Wisconsin Ave.  
Milwaukee, Wisconsin 53202

## MONTREAL, QUEBEC

V-I-K Productions  
2575 Ave. De La Salle  
(514) 256-4608

## NASHVILLE

Bonnie Bucy & Assoc.  
Suite 307  
806 17th Ave. South  
(615) 244-1526

Brite-Star Promotions  
728 16th Ave. S.  
Nashville, 37203  
(615) 244-4064

## NEW YORK

AB&D  
39 W. 55 St.  
10019

David O. Alber  
44 East 53rd St.  
(212) TE 8-8306

Sidney Ascher Assoc.  
1545 Broadway  
(212) LT 1-2287

ATI  
Suite 4V  
300 West 55th Street

R.C. Auletta and Company, Inc.  
59 E. 54 St.  
EL 5-0400

Austin-Drew Assoc.  
520 5th Ave.  
10036  
(212) MU 2-5844

Banner & Greif, Ltd.  
369 Lexington Ave., 10017

Bennett Public Relations  
136 E. 56th  
(212) PL 1-0660

Jack Bernstein Assoc.  
37 W. 57th  
(212) 751-6670

Ivan Black  
900 W. 190th  
(212) LO 8-2724

Mal Braveman  
15 East 48th St.  
(212) EL 5-7752

Chuck Brown  
400 Madison Ave.  
(212) HA 1-4580

Paul Brown  
507 5th Ave.  
(212) MU 7-3071

Budd Prod.  
Budd Hellawell  
157 W. 57th St.  
(212) CI 7-4896

Buddy Clark Assoc.  
350 W. 52nd St.  
(212) JU 6-5777

Connie DeNave & Assoc.  
200 West 57th St.  
(212) JU 6-1330

Contemporary Publicity, Inc.  
4 E. 74 St. 10021  
535-9313

Howard Cook  
15 Charles St. 10014  
(212) 255-4212

Bill Doll  
150 W. 52nd  
(212) JU 6-8894

Marvin Drager  
420 Madison Ave.  
(212) MU 8-1078

Charlie Earle  
250 W. 57th St.  
(212) JU 6-6994

Jack Egan  
45 Wendover Rd.  
Yonkers  
(212) YO 8-7969

888 Advertising  
56 E. 53rd St. 10022  
(212) 753-2250

Harold Ettus  
Hotel Empire  
Broadway & 63rd St.  
(212) CO 5-7400

The Lynn Farnol Group  
50 Rockefeller Plaza  
(212) JU 6-5777

Barry Fiedel (Pr.)  
3311 Shore Parkway  
Bklyn  
(212) 891-1387

Herb Freedman  
300 W. 55 St., 9W  
10019

Robert Ganshaw & John Prescott  
Suite 51B  
1472 Broadway 10036  
581-3710

Richard Gersh Assoc.  
Dick Gersh  
200 W. 57th St.  
(212) PL 7-1101

Gershman, Swaney & Gibson  
162 W. 56 St.  
581-2691, 765-2691

Gifford/Wallace  
315 W. 57  
(212) 581-7980

Goldstein Organization  
200 W. 57th St.  
(212) 581-3800

Glenn Productions  
Ben Arrigo  
157 W. 57th St.  
(212) CO 5-6585

Greengrass Enterprises, Inc.  
595 Madison Ave.  
(212) HA 1-8415

Ren Grevatt  
200 W. 57th St.  
(212) 582-0252

Gurtman-Brown Assoc.  
850 Seventh Ave.  
Suite 1209  
10019  
(212) CI 5-4771

# FOR TOTAL PROMOTION COVERAGE In The East Coast

## CONTACT

**H R PROMOTIONS, INC.**

*Herb Rosen*

(212) 765-1380

888 EIGHTH AVENUE • NEW YORK, N. Y. 10019

9171 Wilshire Boulevard / Suite 540  
Beverly Hills, California 90210  
(area code 213) 274-7855  
cable: LITLEV PUB



330 West 45th Street / Suite 8f  
New York, New York 10036  
(area code 212) 541-7880  
cable: LITLEV PUB





NEW YORK  
BEVERLY HILLS  
CHICAGO  
LONDON  
ROME  
PARIS  
MADRID  
MUNICH

**WILLIAM MORRIS AGENCY, INC.**

ESTABLISHED 1898



The  
Agency  
Of  
The  
Entertainment  
World

**NEW YORK** – 1350 Avenue Of The Americas, New York, N.Y. 10019 • (212) 586-5100, Telex 620165

**CHICAGO** – 435 North Michigan, Chicago, Ill. 60611 • (312) 467-1744

**BEVERLY HILLS** – 151 El Camino, Beverly Hills, Calif. 90212 • (213) 274-7451, (213) 272-4111

**LONDON** – Melrose House, 4 Savile Row, London W. 1, England • Phone: REGent 9361  
*Cable Address* – “Willmorris London” Telex 85127928

**PARIS** – 63 Avenue Franklin Roosevelt, Paris 8e France • Phones: 256.37-20, 225.61-10, 225.69-93  
William Morris Organization *Cable Address* – “Willmorris Paris 008”  
Audiffred Agency *Cable Address* – “Intermission Paris”

**ROME** – Via Nomentana 60, Rome Italy • Phones: 860.740, 850.159, 868.551-2-3  
*Cable Address* – “Willmorris Rome”

*Record  
Promotion  
&  
Publicity  
Offices*

Bernie Ilson  
65 W. 55th St.  
(212) 245-7950

Ivor Associates  
150 W. 55th St.  
(212) 278-3313

Eddie Jaffee  
140 W. 55th St.  
(212) 245-7355

Joe Jones (Pr.)  
300 W. 55, Suite 8Y  
(212) 265-9554

Milton Karle  
440 East 56th St.  
(212) MU 8-8788

Leshin-Grey & Co.  
1711 Broadway 10019  
247-7128

Harold Leventhal Management, Inc.  
200 W. 57 St.  
JU 6-6553

Ann Lipman  
50 E. 76th St.  
(212) 628-1137

Victoria Lucas Associates  
1414 Ave. Of The Americas  
421-2586, UL 2-5171

Jim Mahoney & Assoc.  
510 Madison Ave.  
(212) PL 1-2060

Whit Marshall  
Hotel Somerset  
150 W. 47th St.  
(212) PL 7-2780

The Merrick Co.  
18 E. 48th St.  
(212) PL 2-4111

McFadden, Strauss, Eddy  
& Irwin  
509 Madison Ave.  
(212) 421-7610

Miracle  
170-30 130 Ave.  
Jamaica 11434

M. R. Promo  
Mel Richmond  
1674 Broadway  
(212) 265-9010

Music Makers  
Shelton Towers  
49 St. & Lexington Ave.  
(212) PI 3-4951

Larry Penzell  
501 Madison Ave.  
(212) PL 9-3890-1-2

Bob Perilla  
250 W. 57th St.  
(212) JU 1-5775

Ellen Perl  
405 E. 63 St.  
TE 2-8212

Joe Petralia  
Park Sheraton Hotel  
(212) JU 6-6935

The Plaza Hotel  
Eve Brown  
5th Ave. at 59 St.  
PL 9-3000

Public Relations Corp. of America  
Saul Richmond  
151 E. 50th St.  
(212) PL 2-0040

Arthur Pine Assoc.  
1780 Broadway  
(212) CO 5-7330

Harold Rand & Co.  
50 E. 42nd St.  
986-9095

Saul Richfield  
1697 Broadway  
(212) CI 7-5907-8

Major Robinson  
511 W. 165, Suite 101  
(212) WA 3-5736

Richard H. Roffman Assoc.  
675 West End Ave.  
(212) RI 9-3647

Rogers, Cowan & Brenner  
598 Madison Ave.  
(212) PL 9-6272

Herb Rosen  
888 Eighth Ave.  
(212) 765-1380

Dorothy Ross  
300 W. 55 St.  
(212) 247-5560

Lenny Salidor Inc.  
240 West 55th Street  
10019  
(212) 541-7422

A.A. Schechter Associates, Inc.  
551 5th Ave.  
MU7-1150

Lew Shapiro  
1650 Broadway  
(212) 765-1966

Eve Siegel Assoc.  
35 West 53rd St.  
(212) MU 8-4598

The Billy Smith Operation  
130 W. 80 St.  
877-4849

Effie Smith Enterprises  
250 W. 57 St.  
265-3830-1

Solters & Sabinson  
62 W. 45th  
(212) TN 7-8500

Sound Images  
21 W. 58th St.  
(212) PL 2-6440

Bill Spitalisky (Pr.)  
345 W. 58th  
(212) 246-4280

John Springer Assoc.  
667 Madison Ave.  
(212) 421-6720

The Robert Stigwood Organization, Inc.  
1700 Broadway  
765-7850

The Three Of Us  
130 E. 18 St.  
10003  
677-6904

Cal Stiles (Pr.)  
1958 Burke Ave.  
Bronx  
(212) 547-9588

Stonehedge Productions  
350 E. 52 St.  
Suite 1 E

The Music Agency, Ltd. (TMA)  
888 8th Ave.  
765-2154, 765-2155

Underground Vegetables  
72 E. 93 St.  
427-4633

The Wartoke Concern  
1545 Broadway  
245-5587

Harriet Wasser  
250 W. 57th  
(212) 582-1957

Morton Wax & Assoc. (Pr. & Pub)  
1650 Broadway  
(212) 247-2159

Howard Weissman  
139 E. 53rd  
(212) MU 8-7262

James Yoham Associates  
146 W. 46 St.  
JU6-7408

Irving Zussman  
400 Madison Ave.  
(212) EL 5-5773

**SAN FRANCISCO**

Cathy Furniss & Assoc.  
680 Beach St., Rm. 301  
(415) 885-2807

Public Relations Pacific  
353 Sacramento St.  
(415) 397-7878

**ST. LOUIS MO.**

Herbert Lutz  
4466 W. Pine Blvd.  
(314) 531-4371

**TORONTO, CANADA**

Martin Onrot Associates  
81 Front St. East  
Toronto 215  
(416) 363-6301

**MIKE BORCHETTA PROMOTION**  
California's Leading Sire of Hit Records

Glen Campbell • Tommy Roe • Jose Feliciano  
The Ventures • Leslie Uggams • Al Martino  
Peer Southern Orig. • Quad Records & Stellar Music  
Willard Alexander • Notable Records & Portable Music  
George Pincus • PBM Records • Commander Music

many thanks • 1970 Book Full



**FRED STUART ASSOCIATES**

9126 SUNSET BLVD. • LOS ANGELES, CALIF. 90069 • (213) 274-0674

45 E. 66th ST. • NEW YORK, N.Y. 10021 • (212) 988-4619

PUBLIC RELATIONS  
ADVERTISING

Tony Richland  
really  
promotes!

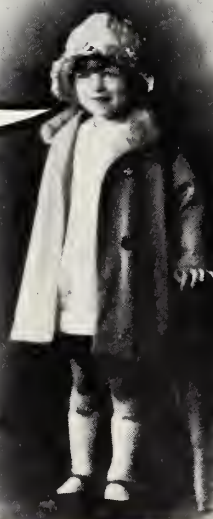

213 Hollywood 7-2151

CREATIVE MANAGEMENT ASSOCIATES, INC.

CMA

CMA

CMA

CMA

CMA

clients are  
those talented people  
we are privileged  
to represent, exclusively,  
in all media of entertainment  
throughout the world.

CMA

**New York**

CMA  
600 Madison Avenue  
New York, New York 10022  
Tel. (212) 935-4000

CMA

CMA

**California**

CMA  
8899 Beverly Boulevard  
Los Angeles, California 90048  
Tel. (213) 278-8899

CMA

CMA

**Chicago**

CMA  
211 East Chicago Avenue  
Chicago, Illinois 60611  
Tel. (312) 943 7100

CMA

CMA

**Miami**

CMA  
7630 Biscayne Boulevard  
Miami, Florida 33138  
Tel. (305) 754-2603

CMA

CMA

**Las Vegas**

CMA  
2765 South Highland  
Las Vegas, Nevada  
Tel. (702) 735-0528

CMA

CMA

**London**

CMA  
22 Grafton Street  
London, W.1.  
Tel. 499-7971

CMA

CMA

**Rome**

CMA  
38 Via Siaci  
Rome, Italy  
Tel. 805-558

CMA

CMA

**Paris**

CMA—Lebovici  
37 Rue Marbeuf  
Paris, France 7  
Tel. 225-60-60

CMA

CMA

CMA

*Record  
Sleeves  
Mailers*

## CALIFORNIA

Barrington Rec. Graphics  
P.O. Box 1036, South Shore  
Alameda (San Francisco) Calif.

Bert Co. Ents.  
1855 Glendale Blvd.  
Los Angeles, Calif. 90026

Container Kraft  
721 E. 61 St.  
Los Angeles, Calif. 90026

Gilmore Envelopes  
4000 Medford St.  
Los Angeles, Calif. 90063

## FLORIDA

Adrian Assocs. Inc.  
The General Bldg.  
6660 Biscayne Blvd.  
Miami, Fla. 33138

## GEORGIA

Jay-Cher Ents.  
P.O. Box 175  
Fairmount, Ga. 30139

## ILLINOIS

Album Graphics Inc.  
35 E. Wacker Dr.  
Chicago, Ill. 60601

- RECORD ENVELOPES, all sizes
  - CORRUGATED BOARDS AND RECORD MAILERS
  - STOCK LEGAL CONTRACTS for Music Publishers and Record Companies
  - PRESSURE-SENSITIVE LABELS (for Recording Studios)
  - FAN CLUB PHOTO CARDS
- Sleeves—Stationery—Album Jackets  
Invoices—Business Cards

Price Lists Available Upon Request  
**ONE STOP SERVICE, INC.**  
133 E. 84th St. New York, N.Y. 10028  
BU 8-4338 — Al Posner

## MARYLAND

Recordings Inc.  
P.O. Box 405  
Cockeysville, Md. 21030

## MASSACHUSETTS

U.S. Envelope  
P.O. Box 951  
Springfield, Mass. 01101

## MINNESOTA

Sentinel Rec. Corp.  
2129 Washington Ave. N.  
Minneapolis, Minn. 55411

## NEW JERSEY

Newark Phonolabels  
1159 Broad St.  
Newark, N.J. 07114

## NEW YORK

Andrews Nunnery  
74 Alpha Plaza  
Hicksville, L.I., N.Y. 11801

Craig Braun Inc.  
56 E. 53 St.  
N.Y.C. 10022

Equitable Bag  
45-50 Van Dam St.  
Long Island City, N.Y. 11101

Fine-Tone Audio Prods.  
24 Cobek Ct.  
Brooklyn, N.Y. 11223

George Alexander Group  
36-25 Prince St.  
Flushing, N.Y. 11354

Globe Albums, Cardinal Ind'l Park  
Hauppauge, L.I., N.Y. 11788

Ivy Hill Litho (Sales)  
18 E. 48 St.  
N.Y.C. 10017

Kaltman Press  
52-35 Barnett Ave.  
Long Island City N.Y. 11104

Le-Bo  
71-08 51 Ave.  
Woodside, N.Y. 11377

Lee-Myles Assocs.  
160 E. 56 St.  
N.Y.C. 10022

One Stop Serv.  
133 E. 84 St.  
N.Y.C. 10028

(Queens Envelope)  
Queens Litho.  
52-35 Barnett Ave.  
Long Island City, N.Y. 11104

Reco-Sleeve  
220 Verde St.  
Farmingdale, N.Y. 11735

Standard Machine  
476 Broome St.  
N.Y.C. 10013

## NORTH CAROLINA

Synder Album  
3083 Indiana Ave.  
Winston-Salem, N.C. 20715

(Con't. on Page 178)

*Envelopes  
&  
Mailers*

## CALIFORNIA

Barrington Rec. Graphics  
P.O. Box 1036 South Shore  
Alameda, Calif.

Bert-Co. Ents.  
1855 Glendale Blvd.  
Los Angeles, Calif. 90026

Container-Kraft  
721 E. 61 St.  
Los Angeles, Calif. 90063

Gilmore Envelope  
4000 Medford St.  
Los Angeles, Calif. 90063

Gopher Prods.  
P.O. Box 812  
Berkeley, Calif. 94701

## CONNECTICUT

Radio Printing Corp.  
1501 State St.  
Bridgeport, Conn. 06605

## DISTRICT OF COLUMBIA

Record-Safe Insured Mailers  
4915 Earliston Dr.  
Washington, D.C. 20016

Ziolkack Corp.  
4620 Wisconsin Ave. N.W.  
Washington, D.C. 20016

## FLORIDA

Adrian Assocs. Inc.  
General Bldg. 6660 Biscayne Blvd.  
Miami, Fla. 33138

Artrec Productions  
P.O. Box 549  
Miami, Fla. 33101

## INDIANA

Woodburn Printing  
25 S. Sixth St.  
Terre Haute, Indiana 47801

## MASSACHUSETTS

U.S. Envelope  
P.O. Box 951  
Springfield, Mass. 01101

## MISSOURI

Ziolkack Corp.  
1217 Independence  
Cape Girardeau, Mo. 63701

Red Flame Recs.  
P.O. Box 563  
Cape Girardeau, Mo. 63501

## NEW MEXICO

Little Ritchie Johnson  
P.O. Box 3  
Belen, New Mexico, 87002

## NEW YORK

Andrews-Nunnery  
74 Alpha Plaza  
Hicksville, L.I. 11801

Brown Paper  
186 Seventh St.  
Brooklyn, N.Y. 11215

Kaltman Press  
52-35 Barnett Ave.  
L.I. City, N.Y. 11104

One Stop Serv.  
133 E. 84 St.  
New York, N.Y. 10028

Queens Litho  
52-35 Barnett Ave.  
L.I. City, N.Y. 11104

Radio Printing Corp.  
49 W. 47th St.  
New York, N.Y. 10036

Sound Packing Corp.  
56 E. 53rd St.  
N.Y.C. 10022

Edward R. White  
342 Madison Ave.  
New York, N.Y. 10017

## OHIO

Queen City Album  
2832 Spring Grove Ave.  
Cincinnati, Ohio 45225

Pioneer Industries  
P.O. Box 4653 Old West End. Sta.  
Toledo, Ohio 43620

## TENNESSEE

Atlantic Envelope  
P.O. Box 888  
Nashville, Tenn. 37202

St. Regis Paper  
820 Seventh Ave. N.  
Nashville, Tenn. 37202

Southern Graphic Inds.  
P.O. Box 303  
Nashville, Tenn. 37202

## WYOMING

RMR  
P.O. Box 82  
Cheyenne, Wyoming 82001

(Con't. on Page 178)

**CORR 12" RECORD MAILERS,** Models 1 to 3 Pak, 5 to 8 Pak, 10 to 15 Pak.

**CORR 7"-12" ENVELOPE MAILERS.** Stapled Sides. Insert-Tape and Mail Models EM 7" 1 to 6 Records. EM 12" 1 to 3 Records.

**DUAL PURPOSE MAILER.** Model 772 25 7" Records or 3-7" Reel to Reel Tape.

**PACKAGE POWER MAILERS.** 60 Sizes Cassettes—Cartridges—Reel to Reel Tape. Shipping Supplies—Kraft Env. Mailers—7" Latex SelfSeal-Kraft and Polly Sleeves—Cushioned Pads. Literature, Prices on Request.

**BROWN PAPER CO. INC.**

186 Seventh St., Brooklyn, N.Y. 11215. Phone (212) 965-3600

**PROMOTIONAL 45 R.P.M. RECORD MAILING ENVELOPES**

**12" LP RECORD MAILING SYSTEM**

Unique Record Mailers — For 1 to 2 LP's  
Variable Record Folders — For 3 to 15 LP's  
7" — 10" — 12" ENVELOPES & BOARDS



**Edward R. White** I N C.

18 EAST 41 STREET, NEW YORK, N.Y. 10017  
MUrray Hill 7-2167

# TONY BENNETT ENTERPRISES

200 WEST 57th STREET, NEW YORK, N.Y. 10022

# ROGERS, COWAN & BRENNER

598 MADISON AVENUE, NEW YORK, N.Y. 10022

250 N. CANON DRIVE, BEVERLY HILLS, CALIF. 90210

# CMA



*Record  
Importers  
&  
Exporters*

## CALIFORNIA

BCA Records Inc.  
719 Gower St.  
Hollywood, Calif. 90038

California Music Co.  
2933 W. Pico Blvd.  
Hollywood, Calif. 90006

Celebrity Concert Corp.  
315 S. Beverly Drive  
Beverly Hills, Calif. 90212

Fermata Int'l Melodies Inc.  
6290 Sunset Blvd.  
Hollywood, Calif. 90028

Festival Rec. Dists.  
2769 W. Pico Blvd.  
Hollywood, Calif. 90006

Festival Rec. Dists.  
161 Turk St.  
San Francisco, Calif. 94102

Lyric Sales Inc.  
P.O. Box 20307 2807 W. Pico Blvd.  
Hollywood, Calif. 90006

M. Stewart & Co.  
204 S. Beverly Dr.  
Beverly Hills, Calif. 90212

New Sound  
8878 Sunset Blvd.  
Hollywood, Calif. 90069

Pacific International  
1223 N. Kingsley  
Hollywood, Calif. 90029

Pacific Music Import & Export  
2525 W. Ninth St.  
Hollywood, Calif. 90006

Rantra Records  
1136 S. Arapahoe Dr.  
Santa Ana, Calif. 92704

Southland Records Dists.  
291 Spinnaker St.  
Orange, Calif. 92668

TDK Electronics Corp.  
6151 W. Century Blvd.  
Hollywood, Calif. 90045

## COLORADO

Indie Dist'g.  
1236 S. Pennsylvania St.  
Denver, Col. 80210

## CONNECTICUT

Aeropole Corp. of America  
P.O. Box 365  
Wilton, Conn. 06897

## DISTRICT OF COLUMBIA

A.E. Schwartz Music Studios  
1301 Delaware Ave. S.W.  
Washington, D.C. 20024

## FLORIDA

Adrian Assocs. Inc.  
6660 Biscayne Blvd.  
Miami, Fla. 33138

Island Music Dists. Ltd.  
P.O. Box 748  
Miami Springs, Fla. 33166

Musical Export Supply Inc.  
7250 N.W. 36th Ave.  
Miami, Fla. 33147

Panart Int'l.  
477 W. 27 St.  
Hialeah, Fla. 33010

Stratford Dance Records  
P.O. Box 887  
West Palm Beach, Fla. 33402

Tone Int'l.  
495 S.E. 10 Ct.  
Hialeah, Fla. 33011

## HAWAII

Microphone Music  
2077 S. Beretania St.  
Honolulu, Hawaii 96814

## ILLINOIS

Gaelic Imports  
5931 W. Chicago Ave.  
Chicago, Ill. 60651

National Educational Servs.  
413 S. Second Ave.  
Libertyville, Ill. 60048

Pan American Records Inc.  
3751 W. 26 St.  
Chicago, Ill. 60623

Polish Rec. Center Of America  
3055 N. Milwaukee Ave.  
Chicago, Ill. 60618

TDK Electronics Corp.  
2906 W. Peterson Ave.  
Chicago, Ill. 60645

## KENTUCKY

Orbit Radio  
P.O. Box 1644 1863 Arlington S  
Louisville, Ky. 40201

## MASSACHUSETTS

David Sternberg Int'l. Sales  
Beech Plain Rd.  
Sandisfield, Mass. 01255

J.K. Ogasian & Sons  
179 Belmont St.  
Worcester, Mass. 01605

Penco Record Co.  
428 Wood St.  
New Bedford, Mass. 02745

## NEW JERSEY

Allied Record Sales  
549 Hamilton Ave.  
Trenton, N.J. 08609

## NEW YORK

Airdisc USA  
949 Broadway  
New York, N.Y. 10010

Albert Schultz Inc.  
116 W. 14 St.  
New York, N.Y. 10011

Alex S. Roberts Assocs. Inc.  
35 Bleecker St.  
New York, N.Y. 10012

Alscap Inc.  
19 W. 34 St.  
New York, N.Y. 10001

Apon Record Co. Inc.  
P.O. Box 3087 Steinway Sta.  
44-16 Broadway  
Long Island City, N.Y. 11103

## TIRED OF WAITING FOR YOUR ORDERS?

THEN TRY US FOR FASTEST DELIVERY ANYWHERE  
LP RECORDS, SINGLE 45 RPM RECORDS, CASSETES,  
8-4 TRACK CARTRIDGES, OPEN REEL TAPES AT  
LOWEST EXPORT PRICES, ALL YOUR NEEDS IN ONE  
SHIPMENT. FREE CATALOGUES ON REQUEST.

**DAVID ESKIN**  
INTERNATIONAL SALES  
400 Riverside Drive, New York 10025  
USA Phone (212) RI 9-4257

## FOR EXPORT ONLY:

### ALL BRANDS

# RECORDS AND TAPES

**ALBERT SCHULTZ, INC.**

116 West 14th St.

NEW YORK, N. Y. 10011, U.S.A.

## RECORDS & TAPES FOR EXPORT

Exclusive Distributor  
For Many Labels

All American Records,  
Tapes & Accessories  
Extremely Attractive Prices  
and  
Speedy Service

**CARDINAL  
EXPORT CORP.**

135 West 29th St.  
New York, N.Y. 10001  
(212) PE-6-5855

## RECORDS • TAPES

Cartridges • Cassettes  
All American brands  
combined into  
**ONE SHIPMENT!**

**ELTRON**  
Export Company

159 Maiden Lane, New York, N. Y. 10038

Cable: **ELTRONCOMP**  
TELEX: 421234

**MIAMI'S** LEADING EXPORTER  
OF RECORDS AND TAPES  
**MUSICAL  
EXPORT  
SUPPLY,  
INC.**

**RAOUL SHAPIRO**  
PRESIDENT AND GEN. MGR.

**7250 N.W. 36th AVE.**

**MIAMI, FLORIDA 33147**

**(305) 836-4781**

A DIVISION OF CAMPUS RECORD DISTRIBUTING, CORP.  
MIAMI, FLORIDA

**CONGRATULATIONS  
CASHBOX  
ON YOUR 28th ANNIVERSARY!**

**AND THANK YOU D.J.'s FOR SELECTING**

**EL CHICANO**

**AS THE #1  
UP AND COMING INSTRUMENTAL GROUP  
OF 1970!**



KAPP RECORDS • A DIVISION OF MCA INC.

*Record  
Importers  
&  
Exporters*

Royal Sound Co. Inc.  
409 N. Main St.  
Freeport L.I. N.Y. 11520

Salient Export Agencies Inc.  
1265 Broadway  
New York, N.Y. 10001

Scott Dist'g. Corp.  
3580 Oceanside Rd.  
Oceanside, L.I. N.Y. 11572

Sluis Co. Inc.  
15 Park Row  
New York, N.Y. 10038

Sylvan Ginsbury Ltd.  
425 Park Ave.  
New York, N.Y. 10016

TDK Electronics  
82 Wall St.  
New York, N.Y. 10005

Worldtone Music  
56-40 187 St.  
Flushing, N.Y. 11365

Zerga  
4 Mill Lane  
Armonk, N.Y. 10504

**OHIO**

Gaelic Imports  
3829 W. 25 St.  
Cleveland, Ohio 44109

**PENNSYLVANIA**

Gaelic Imports  
749 Penn. Ave.  
Pittsburgh, Pa. 15222

**TENNESSEE**

TR Imports  
P.O. Box 5444  
Nashville, Tenn. 37206

**VIRGINIA**

Dance Records  
1438 Springvale Ave.  
McLean, Va. 22101

**Trade Associations**

American Guild of Authors & Composers (AGAC)  
158 W. 55 St.  
New York, N. Y. PL 7-8833

American Guild of Variety Artists (AGVA)  
551 Fifth Ave.  
New York, N. Y. TN 7-5600

American Tape Cartridge Assoc.  
527 Madison Ave.  
New York, N. Y. 10022  
Tel. 212-753-3305

Country Music Assoc. (CMA)  
801-16th Ave. South  
Nashville, Tenn. 615-244-2840

Electronic Industries Assoc.  
1721 De Sales St., N.W.  
Washington 36, D. C.

Int's Record & Music Mens Club (IRMMC)  
c/o Walter Hofer  
221 West 57th St.  
New York, N. Y. JU 2-5030

International Rhythm & Blues Assoc.  
711 West 60th St.  
Chicago, Ill. 60621  
Tel. 312-874-6808

Magnetic Recording Industry Assoc. (MRIA)  
See Electronic Industries Assoc.

Music Operators of America (MOA)  
228 N. La Salle St.  
Chicago 1, Ill. 726-2810-1

National Music Publishers' Association  
460 Park Ave.  
New York, N. Y. PL 1-1930

National Assoc. of Music Merchants (NAMM)  
222 W. Adams  
Chicago 6, Ill. AN 3-0679

Nat'l Academy of Recording Arts & Sciences (NARAS)  
New York: 21 W. 58th St., PL 5-1535  
Hollywood: 1741 Ivar Ave., HO 5-2124  
Chicago: 46 E. Walton, MI 2-6465  
Nashville: Box 6155, Acklen Station  
255-6535

Nat'l Assoc. of Retail Record Dealers  
150 W. 34th St.  
New York, N. Y. 10001  
212-244-1884

Nat'l Assoc. of Radio Announcers (NARA)  
c/o Effie Smith  
250 W. 57 St.  
N.Y.C. 10019  
Suite 1527  
Phone: 212-265-3830

Nat'l Assoc. of Record Merchandisers (NARM)  
Suite 703 Trianon Building  
20 Conshohocken State Rd.  
Bala Cynwyd, Pa. 19004 Tel. (215)  
TE 9-7900

Professional Music Men, Inc.  
1270 Sixth Ave.  
New York 20, N. Y. 10020  
CO 5-7362

Record Industry Assoc. of America (RIAA)  
1 E. 57th St.  
New York 22, N. Y. MU 8-3778

CIDI Record Imports Inc.  
176 Hester St.  
New York, N.Y. 10013

Cardinal Export Corp.  
135 W. 29 St.  
New York, N.Y. 10001

China Publns.  
95 Fifth Ave.  
New York, N.Y. 10003

Daro Exports Ltd.  
424 Madison Ave.  
New York, N.Y. 10017

David Eskin Int'l. Sales  
400 Riverside Drive  
New York, N.Y. 10025

David Sternberg Int'l. Sales  
136 W. 46 St.  
New York, N.Y. 10036

Eltron Export Co.  
159 Maiden Ln.  
New York, N.Y. 10038

Folk Music Int'l.  
56-40 187 St.  
Flushing, N.Y. 11365

German News Inc.  
218 E. 86 St.  
New York, N.Y. 10028

Harbor Rec. Export Corp.  
8724 Third Ave.  
Brooklyn, N.Y. 11209

Hector Dist. Co.  
30 W. 21 St.  
New York, N.Y. 10010

Hellenic Inc.  
367 W. 34 St.  
New York, N.Y. 10001

House of Memorah Inc.  
52 E. Broadway  
New York, N.Y. 10002

International Export Agencies Inc.  
394 Broadway  
New York, N.Y. 10013

Luso Stereo Corp.  
12 W. 44 St.  
New York, N.Y. 10036

Music-By-Mail  
21 West St.  
New York, N.Y.

Peters Int'l. Inc.  
600 Eighth Ave.  
New York, N.Y. 10018

Playette Importers  
585 Ninth Ave.  
New York, N.Y. 10036

Qualiton Records Ltd.  
39-38 58 St.  
Woodside, N.Y. 11377

Record Hunter  
507 Fifth Ave.  
New York, N.Y. 10017

Record & Tape Sales Corp.  
821 Broadway  
New York, N.Y. 10003



*think  
you've heard  
everything?*

**Peters International has thousands of  
imported recordings your customers  
want to hear!**

Our new catalog is off the press and what a giant it is. The new baby weighs over 1½ lbs, 300 pages 8½" x 11" with all albums fully illustrated and lists more than 3,000 LP's and prerecorded tapes from every corner of the world.

**CLASSICAL — POPS — JAZZ AND FOLK MUSIC:** African, Albanian, American, Bulgarian, Chinese, Dutch, English, French, German, Greek, Gypsy, Hungarian, Indian, Irish, Israeli, Italian, Japanese, Latin American, Middle Eastern (including Algerian, Caucasian, Egyptian, Armenian, Lebanese, Moroccan and Turkish), Polish, Portuguese, Romanian, Russian, Scottish, Swiss, Tibetan, Yiddish and Yugoslavian.

**DENMARK**—Odeon.

**ENGLAND**—EMI, Odeon, Parlophone, Waverly, Regal, Studio Two, Music For Pleasure, Voix de l'Orient, Cairophon, Pye, Golden Guinea, Marble Arch, Virtuoso, 77 AFRO, CBS International, Abbey, Cathedral, Sport Disc, Topic, Olympus, Transatlantic.

**FRANCE**—EMI, Odeon, Pathe, Duret Thomson, Voix de l'Islam, Voix de l'Orient, Vogue, Mode, Barclay International, CBS International and RCA International.

**GERMANY**—EMI Odeon, Volksplatte, Gloria, Da Capo, Isarton and CBS International.

**GREECE**—Odeon, Philips, Music Box, P.I., Zodiac, Regal, Minos, Rod Strofos, Zoe, Athenee and Polydor.

**HOLLAND**—Odeon.

**INDIA**—Odeon.

**ISRAEL**—CBS International, Isratone, EMI and RCA International.

**ITALY**—EMI, Odeon, Regal, Parlophone, Pathe, CBS International, RCA International.

**JAPAN**—Toshiba.

**ROMANIA**—Electrecord.

**SPAIN**—EMI, Odeon, Regal, RCA International and Vergara.

**SWEDEN**—Odeon, Parlophone.

In addition, Peters International has available a fully illustrated 64-page catalog listing over 500 Musicassettes and 8 Track Cartridges.

**DEALERS!** *If you have not received our catalogs and price list, please write to:*



Dept. CB,  
**PETERS INTERNATIONAL, INC.**  
600 Eighth Avenue, New York, N.Y. 10018  
Tel. (212) LA 4-4020, LA 4-5535 Cables: Petours

**Record Sleeve  
Mailers (Con't.)**

**OHIO**

Counterpart Music  
3744 Applegate Ave.  
Cincinnati, Ohio 45211

Pioneer Inds.  
P.O. Box 4653  
Old West End Sta.  
Toledo, Ohio 43620

Queen City Album  
2832 Spring Grove Ave.  
Cincinnati, Ohio 45225

Rite Rec. Prod'ns.  
9745 Lockland Rd.  
Cincinnati, Ohio 45215

**PENNSYLVANIA**

H. Royer Smith  
10 & Walnut Sts.  
Philadelphia, Penn. 19107

**TENNESSEE**

Southern Album Serv.  
P.O. Box 303  
Nashville, Tenn. 37202

St. Regis Paper  
830 Seventh Ave. N.  
Nashville, Tenn.



t h e



# Chrysalis

f a m i l y

black widow  
blodwyn pig  
chicken shack  
christine perfect  
clouds  
family  
hard meat  
jethro tull  
king crimson  
liverpool scene  
principal edwards magic theatre  
procol harum  
roy harper  
savoy brown  
small faces  
steeleye span  
ten years after  
writing on the wall

155 oxford street  
london w1  
01-734 9233

360 east 65th street  
new york  
new york 10021  
(212) 535 1292

*Album  
Jacket  
Mfg.*

Container-Kraft  
721 E. 61 St.  
Los Angeles, Calif. 90001

Creative Sound Prod'ns.  
9000 Sunset Blvd.  
Los Angeles, Calif. 90069

Custom Rec. Mfg.  
5810 S. Normandie Ave.  
Los Angeles, Calif. 90044

Imperial Pacific Packaging  
1919 E. 51 St.  
Los Angeles, Calif. 90058

Keysor-Century  
26000 Springbrook Rd.  
Saugus, Calif. 91350

Location Rec'g. Service  
2201 W. Burbank Blvd.  
Los Angeles, Calif. 91506

Modern Album of Calif.  
3104 Vanowen St.  
Burbank, Calif. 91504

Shorewood Packaging of Calif.  
1855 Glendale Blvd.  
Los Angeles, Calif. 90026

#### CONNECTICUT

Lithographic Corp. of America  
1501 State St.  
Bridgeport, Conn. 06605

#### DELAWARE

Ken-Del Prod'ns.  
111 Valley Rd.  
Richardson Park, Del. 19804

#### FLORIDA

Adrian Assocs. Inc.  
The General Bldg.  
6660 Biscayne Blvd.  
Miami, Fla. 33138

Artrec Prod'ns.  
P.O. Box 549  
Miami, Fla. 33101

Criteria  
1755 N.E. 149 St.  
Miami, Fla. 33161

Southeastern Rec. Mfg.  
P.O. Box 2067  
150 W. 29 St.  
Hialeah, Fla.

Unitel  
2515 N.E. 207 St.  
North Miami Beach  
Miami, Fla. 33160

#### GEORGIA

Jay-Cher Ent's.  
P.O. Box 175  
Fairmont, Georgia

#### ILLINOIS

Album Graphisc Inc.  
35 E. Wacker Dr.  
Chicago, Ill. 60601

Chicago Album & Specialty Co.  
417 S. Jefferson St.  
Chicago, Ill. 60607

Fort Dearborn Litho Co.  
6035 W. Gross Point Rd.  
Chicago, Ill. 60648

RCS Press  
1130 W. Adams St.  
Chicago, Ill. 60607

#### INDIANA

Mercury Rec. Mfg.  
1600 Rick Road  
Richmond, Ind. 47374

Modern Album of Indiana Inc.  
1299 Voorhees St.  
Terre Haute, Ind. 47808

Technical Arts & Design Studios  
P.O. Box 33163  
Indianapolis, Ind. 46203

Thomas Zoss Productions  
P.O. Box 755  
1255 E. Madison  
South Bend, Ind. 46624

#### LOUISIANA

Americana Rec'g. Studios  
707 W. California Ave.  
Ruston, Louisiana

#### MARYLAND

Recordings Inc.  
P.O. Box 405  
Cockeysville, Maryland 21030

#### MASSACHUSETTS

U.S. Envelope  
P.O. Box 951  
Springfield, Mass. 01101

#### MINNESOTA

Sentinel Rec. Corp.  
2129 Washington Ave. N.  
Minneapolis, Minn. 55411

Universal Audio Rec'g. Equip. Sales  
2541 Nicollet Ave.  
Minneapolis, Minn. 55404

#### MISSOURI

Red Flame Recs.  
P.O. Box 563  
Kirksville, Missouri 63501

#### NEW JERSEY

Eastern Rec. Mfg.  
901 E. Clements Bridge Rd.  
Runnemede, N.J. 08078

Modern Album of New Jersey Inc.  
Hwys. 202 & 31  
Flemington, N.J. 08822

#### NEW YORK

Audio Rec'g. & Mfg.  
64 Vasser St.  
Garden City, N.Y. 11530

County Box & Album  
201 S. Second Ave.  
Mount Vernon, N.Y. 10550

Craig Braun Inc.  
19 E. 53 St.  
N.Y.C. 10022

George Alexander Group  
36-25 Prince St.  
Flushing, N.Y. 11354

Globe Albums,  
Cardinal Ind'l. Park  
Hauppauge, N.Y. 11788

Imperial Paper Box Corp.  
252 Newport St.  
Brooklyn, N.Y.

Ivy Hill Litho (Sales Office)  
18 E. 48 St.  
N.Y.C. 10017

Lee-Myles Assocs.  
160 E. 56 St.  
N.Y.C. 10022

Lithographic Corp. of America  
49 W. 47 St.  
N.Y.C. 10036

(Con't on next Page)

# Package Deal

Everything you need...

Covers and Liners / 7 and 12 inch Sleeves  
Labels / Tape Graphics / Art and Design  
Displays / Promotion Material / Browser Boxes

...from the industry's leading lithographer

**Queens  
Lithographing  
Corporation**

THE VISUAL COMMUNICATIONS COMPANY

52-35 Barnett Avenue  
Long Island City, N.Y. 11104  
212 457-7700



**We make perfect packages too  
—for records, cartridges  
and cassettes.**

*We design them, we print them, and we fabricate them.  
Of course we also advertise them.*

**Lee-Myles Associates, Inc.**

160 East 56 Street, New York, NY 10022 • (212) 758-3232 • Cable: LEEMYLES • Plant: 645 West 44 Street  
(Also preprinted full color: instant album covers, instant cartridge labels, instant cassette inserts)

# Henry Mancini thanks all the D.J.'s who made his the #1 Most Programmed Orchestra in America.



And we thank Henry Mancini.

**RCA** Records  
and Tapes



LSPX-1000/P8S-1596/PK-1596



LSP-4350/P8S-1583/PK-1583



LSP-4140/P8S-1441/PK-1441

*Record  
Platers*

#### ARIZONA

Wakefield Mfg.  
P. O. Box 6037  
Phoenix, Arizona 85005

#### CALIFORNIA

AFM Eng'g.  
6209 Santa Monica Blvd.  
Los Angeles, Calif. 90038

Alco Research & Eng'g.  
6201 Santa Monica Blvd.  
Hollywood, Calif. 90038

Audio Plating Co.  
1037 N. Sycamore Ave.  
Hollywood, Calif. 90038

Capitol  
P. O. Box 65856  
3061 Fletcher Dr.  
Los Angeles, Calif. 90065

C. P. MacGregor  
729 S. Western Ave.  
Los Angeles, Calif. 90005

Custom Rec. Mfg.  
5810 S. Normandie Ave.  
Los Angeles, Calif. 90044

Finebilt Mfg.  
931 N. Citrus Ave.  
Hollywood, Calif. 90038

Keysor-Century  
26000 Springbrook Rd.  
Saugus, Calif. 91350

Lewis Rec. Mfg.  
307 E. Beach St.  
Inglewood, Calif. 90302

Monarch Rec. Mfg.  
4852-56 W. Jefferson Blvd.  
Los Angeles, Calif. 90016

Rainbo  
1041 N. Las Palmas  
Hollywood, Calif. 90038

Record Broadcast  
237 S. Bent Ave.  
San Marcos, Calif. 92069

Research Craft  
1011 N. Fuller  
Los Angeles, Calif.

Tone Plating Corp.  
949 N. Orange Dr.  
Hollywood, Calif. 90038

Worldex Mfg.  
1248 S. Berendo St.  
Los Angeles, Calif. 90006

#### CONNECTICUT

'Cook Labs Inc.  
351 Courtland Ave.  
Glenbrook (Stamford), Conn. 06906

#### FLORIDA

Criteria  
1755 N. E. 149 St.  
Miami, Fla. 33161

Southeastern Rec. Mfg.  
P. O. Box 2067  
150 W. 29 St.  
Hialeah, Fla. 33012

#### ILLINOIS

International Rec'g Co. (IRC)  
1649 W. Evergreen Ave.  
Chicago, Illinois 60622

Sheldon  
211 E. Grand Ave.  
Chicago, Illinois 60611

#### INDIANA

Mercury Rec. Mfg.  
300 S. First St.  
Richmond, Indiana

#### LOUISIANA

Phono Rec. Pressing  
95 First St.  
Gretna (New Orleans), La. 70058

#### MARYLAND

Recordings Inc.  
P. O. Box 405  
Cockysville, Md. 21031

#### MICHIGAN

Archer Rec. Pressing  
6552 E. Davison  
Detroit, Mich. 48212

Sound Inc.  
56880 North Ave.  
New Haven, Mich. 48048

#### MINNESOTA

Sentinel Rec. Corp.  
2129 Washington Ave. N.  
Minneapolis, Minn. 55411

Universal Audio Rec'g Equip  
2541 Nicollet Ave.  
Minneapolis, Minn. 55404

#### NEW YORK

Audio Matrix  
915 Westchester Ave.  
Bronx, N. Y. 10459

Capitol Custom Services  
1290 Ave. of The Americas  
New York, N. Y. 10019

Mastercraft Rec. Plating  
619 W. 54 St.  
New York, N. Y. 10019

#### OHIO

Boddie Recording  
12202 Union Ave.  
Cleveland, Ohio 44105

King Custom Rec. Serv.  
1540 Brewster Ave.  
Cincinnati, Ohio 45207

Queen City Album  
2832 Spring Gove Ave.  
Cincinnati, Ohio 45225

Pama Records Inc.  
4991 Osborn Rd.  
Cleveland, Ohio 44128

Rite Record Productions  
9745 Lockland Rd.  
Cincinnati, Ohio 45215

S. J. Shaw Plating  
2604 Glendora Ave.  
Cincinnati, Ohio 45219

#### PENNSYLVANIA

Allentown Records  
10 & Walnut Sts.  
Allentown, Pa. 19107

#### RHODE ISLAND

Johnston Sound Service  
111 Sweet Ave.  
Pawtucket, R.I. 02861

#### TENNESSEE

Nashville Phono Matrix Inc.  
310 Chestnut St.  
Nashville, Tenn. 37210

Nashville Record Plating Inc.  
706 Allison St.  
Nashville, Tenn. 37203

#### TEXAS

Tanner'n' Texas  
1422 W. Poplar  
San Antonio, Texas 78207

#### WISCONSIN

Cuca Record Mfg.  
123 Water St.  
Sauk City, Wis. 53583

#### WYOMING

RMR  
P. O. Box 82  
Cheyenne, Wyo. 82001

*Album  
Jacket  
Mfg.*

Modern Album  
119-01 22 Ave.  
College Point  
N.Y.C. 11356

One Stop Serv.  
133 E. 84 St.  
N.Y.C. 10028

Profile Press  
151 W. 25 St.  
N.Y.C. 10001

Progressive Label  
286 Stanhope St.  
Brooklyn, N.Y. 11237

Queens Envelope  
52-35 Barnett Ave.  
Long Island City, N.Y. 11104

Record Albums  
286 Stanhope St.  
Brooklyn, N.Y. 11237

Robins Inds.  
15-58 127 St.  
Flushing, N.Y. 11356

Sound Packaging  
56 E. 53rd St.  
N.Y.C. 10022

Shorewood Packaging  
724 Fifth Ave.  
N.Y.C. 10019

Tee Packaging  
22 Jones St.  
N.Y.C. 10014

#### NORTH CAROLINA

Snyder Album  
3083 Indiana Ave.  
Winston-Salem, N.C. 27105

#### OHIO

King Custom Rec. Serv.  
1540 Brewster Ave.  
Cincinnati, Ohio 45207

Mega City Music  
38 Linden Ave.  
Dayton, Ohio 45403

Mus-I-Col  
780 Oakland Park  
Columbus, Ohio 43224

Praise Rec'gs.  
15589 Freed Rd. S.E.  
Minerva, Ohio

Queen City Album  
2832 Spring Grove Ave.  
Cincinnati, Ohio 45225

Rite Rec. Prod'ns.  
9745 Lockland Rd.  
Cincinnati, Ohio 45215

#### PENNSYLVANIA

Allentown Rec.  
10 & Walnut Sts.  
Allentown, Pa. 19107

G & C Rec. Mfg.  
2724 Penn Ave.  
Pittsburgh, Pa. 15222

H. Royer Smith  
10 & Walnut Sts.  
Philadelphia, Pa. 19107

Jack Howard Promos  
2733 Kensington Ave.  
Philadelphia, Pa. 19134

Marjon  
930 Woodview Pl.  
Sharon, Pa. 16146

Praise Recs.  
P.O. Box 428, Dept. B  
Stoneboro, Pa. 16153

#### TENNESSEE

Tri-State Rec'g.  
1767 Fort Henry Dr.  
Kingsport, Tenn. 37664

Music City Album Co.  
219 Russell St.  
Nashville, Tenn. 37213

Nashville Rec. Prod'ns.  
905 17 Ave. S.  
Nashville, Tenn. 37212

Southern Album Serv.  
Southern Graphic Inds.  
P.O. Box 303  
Nashville, Tenn. 37202

Vibrant Rec'gs.  
Rt. 1  
Newport, Tenn. 37821

World Wide Recs. Inc.  
5815 Old Harding Pike  
Nashville, Tenn. 37205

#### TEXAS

M & M Rec. Prod'n. Co.  
P.O. Box 36529  
8004 Wednesbury Ln.  
Houston, Texas 77036

Tanner 'N' Texas  
1422 W. Poplar  
San Antonio, Texas 78207

#### WISCONSIN

Cuca Recs. Mfg.  
123 Water St.  
Sauk City, Wis. 53583

#### WYOMING

RMR (Rocky Mountain Rec'g.)  
P.O. Box 82  
Cheyenne, Wyoming 82001

**Cash Box: A Trade  
Magazine That  
Serves Its Industry**



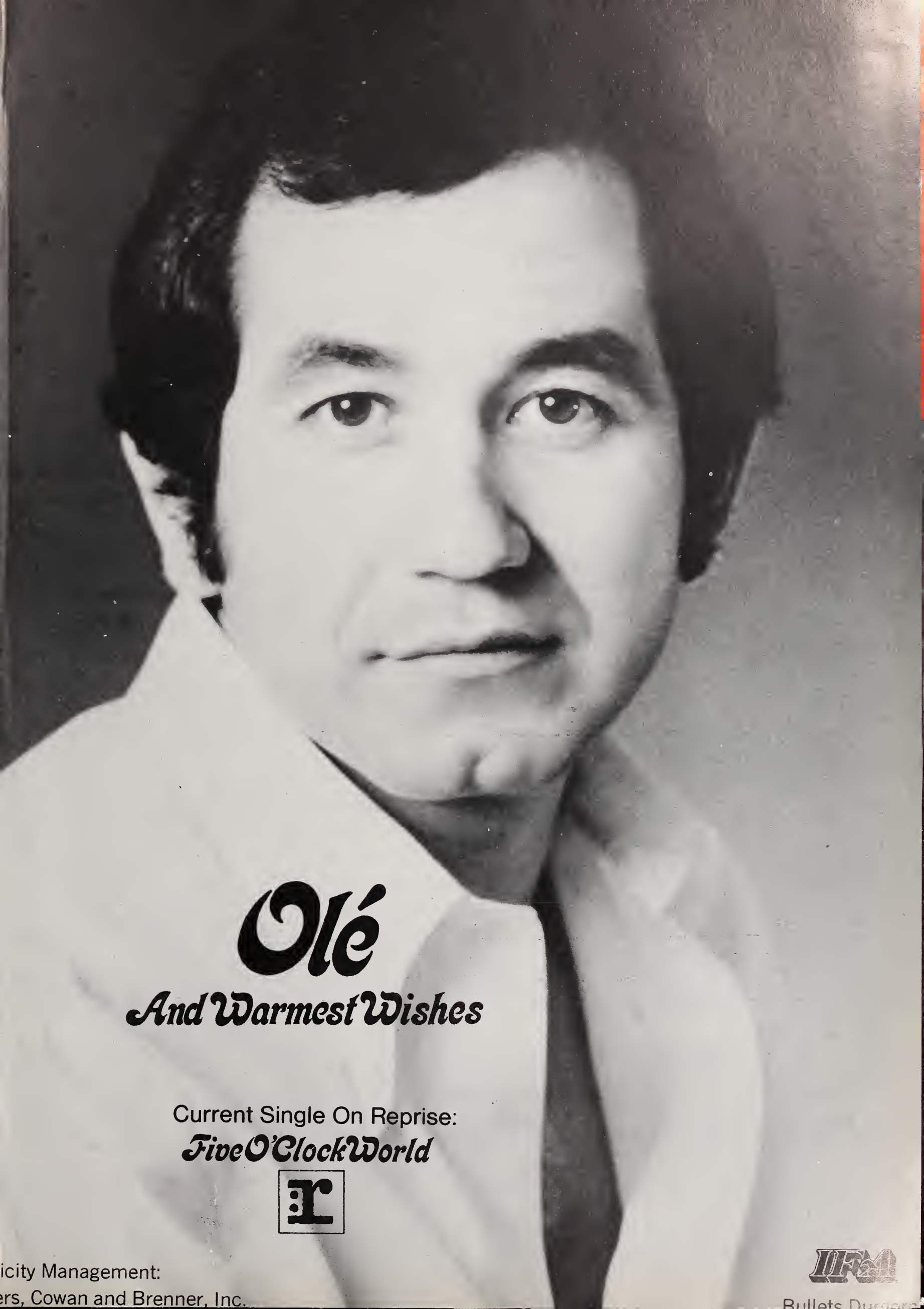

***Olé***  
***And Warmest Wishes***

Current Single On Reprise:  
***Five O'Clock World***



Publicity Management:  
Cowan and Brenner, Inc.

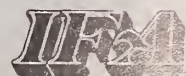

Bullets Duragra

# Recording Studios

## A

**A A A Recording Studios, Inc.**  
835 Dorchester Ave.  
Boston, Mass 02125

**A & M Records**  
1416 N. La Brea Ave.  
Hollywood, Calif. 90028

**A & R Recording, Inc.**  
322 W. 48th St.  
New York, N. Y.

**A-1 Sound Studios**  
242 W. 76th St.  
New York, N. Y.

**Able Turntable & Tape**  
6912 Hollywood Blvd.  
Hollywood, Calif. 90028

**A C A Recording Studios**  
1017 Westheimer  
Houston, Texas 77006

**Accent Sound, Ltd.**  
48 W. Biddle St.  
Baltimore, Md. 21201

**Ace Recording Studios, Inc.**  
1 Boylston Pl.  
Boston, Mass, 02116

**Action Recording Co.**  
2207 El Camino Real  
San Mateo, Calif. 94403

**Adelphi Studios**  
516 E. Indian Spring Drive  
Silver Springs, Md. 20901

**Adrian Assoc. Inc.**  
6660 Biscayne Blvd.  
Miami, Fla. 33138

**Agency Recording**  
20 N. Wacker  
Chicago, Ill.

**Agency Recording**  
1730 E. 24 St.  
Cleveland, Ohio 44114

**Air-Tone Sound & Recording**  
2330 Market St.  
Philadelphia, Pa. 19103

**Akron Recording**  
790 Main St.  
Akron, Ohio

**Alba-Trio Recording**  
130 Seventh St.  
Pittsburgh, Pa. 15228

**Alcon Recording**  
4435 Mayfield Rd.  
Cleveland, Ohio 44121

**Alcor Inc./Pyramid**  
215 S. Tioga  
Ithaca, N. Y. 14850

**All-Purpose Recording Studios**  
2223 S. Dale Mabry Hwy.  
Tampa, Fla. 33609

**Allegro Sound**  
1650 Broadway  
New York, N. Y. 10019

**Alteen Recording Co.**  
8204 S. Stony Island  
Chicago, Ill.

**Alto Fonic Programming**  
6362 Hollywood Blvd.  
Hollywood, Calif. 90028

**America's Productions, Inc.**  
600 Biscayne Blvd.  
Miami, Fla. 33132

**American Line Recording Studios**  
15 E. Franklin St.  
Bellbrook, Ohio 45305

**Americana Recording Studios**  
PO Drawer L, 707-709 W. California Ave.  
Ruston, La. 71270

**American Sound Studios**  
827 Thomas St.  
Memphis, Tenn. 38107

**American Tape Duplicators**  
5727 W. Jefferson Blvd.  
Los Angeles, Calif. 90016

**Amigo Recording Studios**  
11114 Cumpston Ave.  
N. Hollywood, Calif. 91601

**Ampex Corp.**  
5335 N. Tacoma  
Indianapolis, Ind. 46220

**Andrus Recording Studios**  
3204 Broadway  
Houston, Texas 77017

**Apollo**  
1915 N. Quince  
Olympia, Wash. 98501

**Apostolic Studios**  
53 E. 10th St.  
New York, N. Y. 10003

**Ardent Recording Studios**  
1457 National St.  
Memphis Tenn. 38122

**Artcraft Recording**  
285 E. 49th St.  
Brooklyn, N. Y. 11203

**Arthur Smith**  
5457 Old Monroe Rd.  
Charlotte, N. C. 28211

**Artie Fields Productions, Inc.**  
9430 Woodward Ave.  
Detroit, Mich. 48202

**Artisan Sound Recorders**  
1710 N. La Brea Ave.  
Hollywood, Calif. 90046

**Artist Recording**  
320 Mill St.  
Cincinnati, Ohio 45215

**Artists Recording Studio**  
5904 Sunset Blvd.  
Hollywood, Calif. 90028

**Ascot Recording Studio**  
5904 Sunset Blvd.  
Hollywood, Calif. 90028

**Associated Recording Studios**  
723 Seventh Ave.  
New York, N.Y. 10019

**Athena Recording**  
P.O. Box 68  
Brentwood, Texas 37027

**Atlantic Recording Studio**  
11 W. 60th St.  
New York, N.Y.

**Audio City Production Studios**  
3009 E. Lake St.  
Minneapolis, Minn. 55406

**Audio Graphic Services**  
1516 Ferris Ave.  
Royal Oak, Michigan 48067

**Audio Recorders**  
3941 Fifth Ave.  
San Diego, Calif. 92103

**Audio Recording**  
2227 Fifth Ave.  
Seattle, Washington

**Audio Recording Studios, Inc.**  
601 Rockwell Ave.  
Cleveland, Ohio 44114

**Audio Sound Services**  
104 E. Bloomfield St.  
Rome, N. Y. 13440

**Audiofonics**  
15 W. Lenoir St.  
Raleigh, N. C. 27602

**Audiotek Recording Studios**  
711 W. Broadway  
Minneapolis, Minn. 55411

**Audio Recorders of Ariz.**  
3830 N. 7th St.  
Phoenix, Ariz.

**Aura Recording**  
136 W. 52nd St.  
New York, N. Y. 10019

**Aura-Sonic Labs, Inc.**  
236 E. 25th St.  
Baltimore, Md. 21218

**Averbeck-Warren Assocs.**  
815 Ohio St.  
Quincy, Ill. 62301

**Axis**  
3290 Harrison St.  
San Francisco, Calif. 94110

## B

**Baldwin Sound Productions**  
5252 Trindle Rd.  
Mechanicsburg, Pa. 17055

**Balkan Music Co.**  
6917 Cermak  
Berwyn, Ill.

**Band Box Recording Studios**  
5136 W. 141st Ave.  
Denver, Colorado 80226

**Band n' Vocal Mobile Recording Service**  
770 'G' North Main  
Orange, Calif. 92667

**Barbara Allan Productions**  
PO Box 207  
Kalamazoo, Mich. 49005

**Bee Jay Recording Studios**  
Box T, Winter Park  
Orlando, Fla. 32789

**Bel-Aire**  
1740 W. 47th St.  
Chicago, Ill. 60609

**Bell Sound Studios**  
237 West 54th St.  
New York N. Y.

**Belt Sound Studio**  
979 E. Broadway  
Muskegon, Mich. 49444

**Beltone Recording Corp.**  
4 West 31st St.  
New York, N. Y.

**Ben Parsons Productions**  
1743 Warm Springs Rd.  
Columbus, Ga. 31904

**Ben-Scott Recording**  
6123 SW 68 St.  
South Miami, Fla. 33143

**Benson Sound Studio**  
3707 S. Blackweider Ave.  
Oklahoma City, Okla. 73119

**Benrene Rec. Studio**  
Rt. 1 Twinville Rd.  
Powell, Tenn. 37849

**Bill Rase Recording Studi**  
2904 Franklin Blvd.  
Sacramento, Calif. 95818

(Con't on next Page)

## The Sound is Kim Records

Every Lover  
Have a Heartache

B/W  
Lets Make a New Start

Clarence Williams  
15 Years My Love  
Was in Vain

B/W  
Lead Me Where You Wanna

Midel "T" Slim

Kim Records  
c/o Mikel Hook Publ. Co.  
254 E. 29th St.  
Los Angeles, Calif. 90011

# WOULD YOU BELIEVE . . . ?

Everybody laughed at the idea of recording in a funky little studio in **MUSCLE SHOALS, ALA. . . . UNTIL**

Joe South      Clarena Carter      Bobbie Gentry  
Wilson Pickett  
Aretha Franklin      Otis Redding  
Joe Tex      Ray Stevens  
Lotta James      Brook Benton  
The Tams      Candi Staton      Little Richard  
Tommy Roe      Jimmy Hughes  
Solomon Burke      James and Bobby Purify      Lee Simon  
RICK HALL?

THEY ALL CUT HITS HERE . . . funny \$



MUSCLE SHOALS . . . 603 E. AVALON AVE. . . . CODE (205) 381-0801  
MEMPHIS . . . 1740 BELLEVUE . . . CODE (901) 774-5440

# Recording Studios

## B

**Blackwood Recording Studio**  
3933 Summer  
Memphis, Tenn. 38122

**Blue Soul Studio**  
4427B Creshaw Blvd.  
Los Angeles, Calif. 90043

**Boddie Recording Studio-lab**  
12202 Union Ave.  
Cleveland, Ohio 44105

**Bonita Recording Studio**  
3346 Glen Abbey Blvd.  
Chula Vista, Calif. 92010

**Boutwell Recording Studios**  
1929 Cahaba Rd.  
Birmingham, Ala. 35223

**Boulevard Recording Studio**  
632 N. Dearborn  
Chicago, Ill.

**Boyd Recording Service**  
801 Core St.  
Dallas, Texas 75207

**Bradley's Barn**  
1609 Hawkins St.  
Nashville, Tenn. 37203

**Bradley's Recording Co.**  
531 N. Howard St.  
Baltimore, Md. 21201

**Brandt's Recording Studio**  
1030 48th St.  
Sacramento, Calif. 95819

**Brians Recording Studio**  
2200 Sunnybrook  
Tyler, Texas 75701

**Britt Sound Studio**  
Box 727  
Biscoe, N. C. 27209

**Broadway Recording Studios**  
1697 Broadway  
New York, N. Y.

**Bruce Kirby Sound**  
1606 Cahuenga Blvd.  
Hollywood, Calif. 90028

**Bud Pressner Recording Service**  
4839 Broadway  
Gary, Ind. 46409

## C

**California Recorders**  
5203 Sunset Blvd.  
Hollywood, Calif. 90028

**Capital City Sound Studios**  
PO Box 14687  
Baton Rouge, La 70808

**Capitol Records**  
Capitol Tower  
Hollywood, Calif.

**Capitol Records**  
806-16th Avenue S.  
Nashville, Tenn.

**Capitol Records, Inc.**  
151 West 46th St.  
New York, N. Y.

**Capricorn Sound Studios**  
534 Broadway  
Macon, Ga. 31201

**Cardona Recording Studio**  
3658 S. Perry St.  
Montgomery, Ala. 36105

**Carousel Productions, Inc.**  
25th and Chase St.  
Denver, Colorado 80214

**Castle Productions**  
642 Birches Dr.  
Lake Geneva, Wis. 53147

**Catero Sound Co.**  
1548 Market St.  
San Francisco, Calif. 94102

**Cavern Recording Studios**  
16400 E. Truman Rd.  
Independence, Mo. 64050

**Cedarwood Sound Studio**  
815 16 Ave. S  
Nashville, Tenn. 37203

**Cee Recording Service**  
PO Box 8921  
Albuquerque, N.M. 87108

**Century Custom Recs**  
25 Campion Rd.  
Cape Elizabeth, Maine 04107

**Century Custom Recording**  
5712 College Ave.  
Des Moines, Iowa 50310

**Century Custom Rec'g Service**  
6010 Goodrich Rd.  
Clarence Center, Buffalo, N. Y. 14032

**Century Custom Rec'g Service**  
Main St.  
Colchester, Vt. 05446

**Century Custom Rec'g Service**  
5006 W. Houston Ave.  
Spokane, Wash. 99208

**Century Custom Recording Service**  
PO Box 862  
Springfield, Mo. 65801

**Century Recorders**  
995 S. Clermont  
Denver, Colorado 80222

**Century Recorders**  
1220 NW 39  
Oklahoma City, Okla. 73118

**Century Recorders of Greater Chicago**  
1 S. 303 Ingersoll Lane  
Village Park, Ill. 60181

**Century Recording**  
2 Portland St.  
Holyoke, Mass. 01040

**Century Recording Corp.**  
1063 Shepard Hills Blvd.  
Macedonia, Ohio 44056

**Century Recording Service**  
11 S. Idlewild  
Memphis, Tenn. 38104

**Century Sound**  
135 W. 52 St.  
New York, N. Y.

**Champ Recording Studio**  
1807 Indian Ridge Road  
Johnson City, Tenn. 37601

**Channel 1 Productions**  
1061 Elmira St.  
Mobile, Ala. 36604

**Charles Bennett Productions**  
4150 Fox St.  
Denver, Colorado 80216

**Chattanooga Recording Studio**  
1077 Duncan Ave.  
Chattanooga, Tenn. 37404

**Cherokee Sound Studio**  
P.O. Box 175  
Fairmount, Ga. 30139

**Chess Record Corp.**  
320 E. 21st St.  
Chicago, Ill.

**Chime Rec. Prod'n Co.**  
223 Jerusalem Ave.  
Hempstead, N.Y. 11550

**Cinema Recording**  
21 W. 46 St.  
New York, N.Y. 10036

**Cinema Sound Inc.**  
1635 Division S.  
Grand Rapids, Mich. 49507

**Cine-Vox Studios**  
12 E. 41 St.  
New York, N.Y. 10017

**Cinemasound Inc.**  
1755 NE 149th St.  
Miami, Fla. 33161

**C L B Recording Studio**  
1515 Hurd Rd.  
Monroe, Mich. 48161

**Cleveland Recording**  
1515 Euclid Ave.  
Cleveland, Ohio 44115

# NATURAL SOUND STUDIO



A DIVISION OF WAYSIDE RECORDS, INC.

## NEW ENGLAND'S LARGEST 8 TRACK RECORDING STUDIO

THE MAIN ROOM IS 40 feet wide by 60 feet long  
WITH STEINWAY PIANO and HAMMOND B-3 ORGAN/  
COMPLETE PHASING AVAILABLE/  
SPECIAL EFFECTS FILTERS  
NASHVILLE TRAINED ENGINEERS  
THE GREATEST ROCK & COUNTRY SOUND  
IN THE ENTIRE NORTHEAST

FOR FURTHER INFORMATION AND RATES,  
CALL 617/897-7359 or 617/259-9482.

63 Main Street/Maynard, Mass. 01754/  
Paul Dusty Burnell, General Manager

(Cont. on next page)



# When we say stereo separation



## We mean stereo separation!

Coast to coast.  
Each with 4-8-16 track capability.  
Any and all services.  
Live sessions to finished masters.  
Mix-down rooms.  
Cutting rooms.  
Tape duplicating rooms.

### **DECCA RECORDING STUDIOS**

50 West 57th Street  
New York, New York 10019  
(212) 759-7500  
Contact: Charles Blake

### **MCA RECORDING STUDIOS**

100 Universal City Plaza  
Universal City, California 91608  
(213) 985-4321  
Contact: Brent Albright



# Recording Studios

Columbia Records  
6121 Sunset Blvd.  
Hollywood, Calif. 90028

Columbia Records  
804 16th Ave. So.  
Nashville, Tenn. 37203

Columbia Records  
Studio B  
49 E. 52nd St.  
New York, N.Y.

Columbia Records  
Studio E  
49 E. 52nd St.  
New York, N.Y.

Columbia Records  
30th Street Studio  
307 E. 30th St.  
New York, N.Y.

Columbus Recording  
916 Kearny St.  
San Francisco, Calif.

Commercial Features Inc.  
1411 N. Illinois St.  
Indianapolis, Ind. 46202

Commercial Recording, Inc.  
333 Cooke St.  
Honolulu, Hawaii 96813

Compose-Revival Recs.  
3973 18 St.  
Ecorse, Mich. 48229

Concert Recording  
3318 Platt Ave.  
Lynwood, Calif. 90262

Contact  
864 Kerr Ave.  
Memphis, Tenn. 38106

Continental Recordings, Inc.  
12 Irving St.  
Framingham, Mass. 01701

Cooper State Recording Co., Inc.  
815 E. Broadway  
Tucson, Ariz. 85719

Coulee Recording Corp.  
RR 1  
Stoddard, Wis. 54658

Courier-Empire Recording  
414 Croghan St.  
Freemont, Ohio 43420

Creative Workshop Inc.  
2804 Azalea Pl.  
Nashville, Tenn. 37204

Crescent City Sound Studios  
1060 Gatewood Ave.  
Greensboro, N.C. 27405

Criteria Recording Studios  
1755 N.E. 149th St.  
Miami 61, Fla.

Crown Recording Studio  
5642 S. Spaulding  
Chicago, Ill. 60629

Crystal-Sound Recording  
1014 N. Vine St.  
Hollywood, Calif. 90038

Cue Recording  
117 W. 46 St.  
New York, N.Y. 10036

Custom Audio-JPL Rec. Co.  
1088 Sixth Ave.  
Des Plaines, Ill. 60016

Custom Fidelity, Inc.  
7925 Santa Monica Blvd.  
Hollywood, Calif. 90046

Custom Sound Studio  
1317 S. Peach  
Tyler, Texas 75701

Cutler's Recording Studio  
3527 S. Staples  
Corpus Christi, Texas 78411

## D

Damon Recording Studio  
117 W. 14 St.  
Kansas City, Mo. 64116

Dandon Recorders  
80 W. 40 St.  
New York, N.Y. 10018

Dani Studios  
32 W. Klubertanz Dr.  
Sun Prairie, Wis. 53590

Darvin Studio  
100 St. Marks Place  
New York, N.Y. 10009

Dave Kennedy Rec'g. Studios  
2755 N. Third St.  
Milwaukee, Wis. 53212

DBM Recording Studio  
1516 Hawkins St.  
Nashville, Tenn. 37203

D C T Recorders  
6414 Sunset Blvd.  
Hollywood, Calif. 90028

Decca Records  
50 West 57th St.  
New York, N.Y.

DeClerq Studio  
127 Main St.  
Binghamton, N.Y. 13905

Dee-Bee Recording Service  
S. Camp St. Extension  
Windsor, Pa. 17366

Deep South Recording Studios  
P.O. Box 2306  
Baton Rouge, La. 70821

Dell Recording  
217 Columbia St.  
Utica, N.Y. 13502

Delta Recording Center  
910 Currie St.  
Fort Worth, Texas

Delta Recording Co.  
612 Prairie St.  
Winnsboro, La. 71295

Delta Recording Corp.  
1564 Broadway  
New York, N.Y.

Demo-Vox Sound Studio  
1038 Bay Ridge Ave.  
Brooklyn, N.Y. 11219

Derrick Recording Studios  
1448 N. Harvard  
Tulsa, Okla. 74110

Deryck Waring Recordings  
25 W. 43 St.  
New York, N.Y.

Desmo Recording Studio  
P.O. Box 171  
Bellevue, Wash. 98004

Dial Recording  
323 13 Ave NE  
Minneapolis, Minn. 55413

Diamond Jim Recording Co.  
12318 Dexter Blvd.  
Detroit, Mich. 48206

Dick Charles Recording Service  
729 Seventh Ave.  
New York, N.Y. 10019

Dimension Records  
55505 Melrose Ave.  
Hollywood, Calif.

Direct Recordings, Inc.  
18 E. 50 St.  
New York, N.Y. 10022

Don Upchurch Productions  
Carolina Ave.  
Ahoskie, N.C. 27910

Doppler Ents. Inc.  
3720 Oakcliff Rd. NE  
Atlanta, Ga. 30340

Double U Sound Recording, Inc.  
P. O. Box 4557  
3973 18th St.  
Ecorse, Mich. 48229

## E

E.A.B. Recording Studios  
248 Lisbon St.  
Lewiston, Maine 04240

Echo Sound Recording  
2686 Hempstead Turnpike  
Levittown, N.Y. 11756

Eight Track Recording Co.  
664 N. Michigan  
Chicago, Ill.

(Con't. on next page)

C M C Recording Studios  
1201 Research Blvd.  
St. Louis, Mo. 63132

Coast Recording  
829 Folsom  
San Francisco, Calif.

Columbia Records  
630 No. McClure Court  
Chicago, Ill. 60611

# 69/70 SEASON

The Band  
Iron Butterfly  
Paul Butterfield  
B.B. King  
Bobby Bloom  
John Sebastian  
Miriam Makeba  
Cashman, Pistilli & West  
Coke  
Pontiac  
Film Score "The Landlord"

16 TRACK RECORDING

# The Hit Factory inc.

701 Seventh Avenue, New York, N.Y. 10036  
353 West 48th street, New York, N.Y. 10036

212-581-9590

THANKS TO:

JONI MITCHELL / PEGGY LEE  
ELMER BERNSTEIN / DAVE GRUSIN  
BARBARA MC NAIR / BING CROSBY  
DIONNE WARWICK / ROSS BAGDASARIAN  
NILSSON / SMOTHERS BROTHERS / HENRY  
MANCINI / KLEIN-BARZMAN-HECHT  
GROSS-PERA-ROCKE FOR THE  
NICE THINGS THEY'RE

SAYING  
ABOUT  
OUR  
STUDIOS.

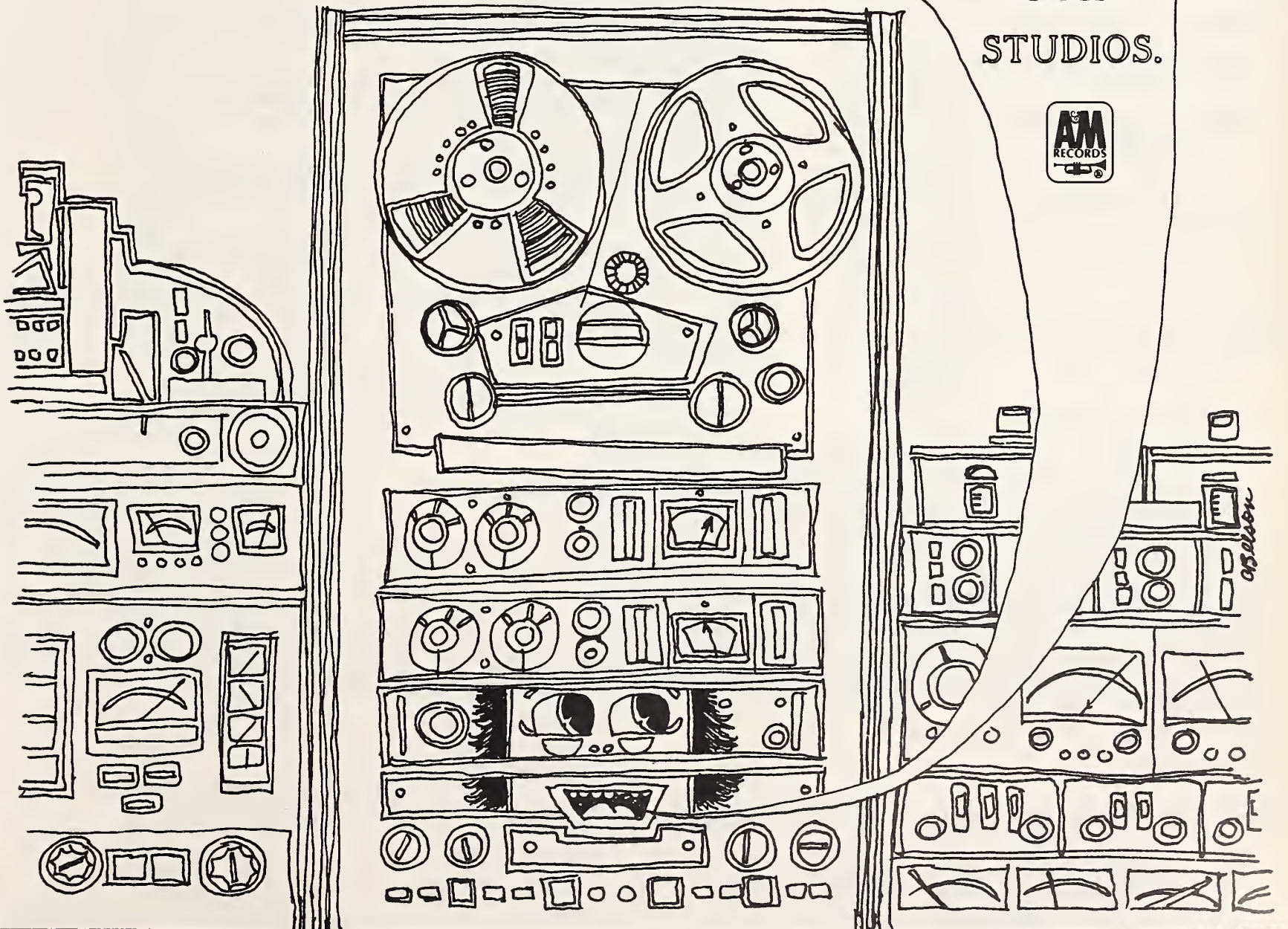

# Recording Studios

Electric Lady  
52 W. Eighth St.  
New York, N.Y. 10011

Electronic Specialty Co.  
135 N. Illinois  
Springfield, Ill. 62702

Electro-Vox Studios  
5546 Melrose Ave.  
Hollywood, Calif. 90038

Elite Recordings, Inc.  
333 Ave. Of the Americas  
New York, N.Y. 10014

Emmit Brooks Rec'g Studio  
PO Box 998  
Las Cruces, N.M. 88047

Etteilla Inc.  
120 E. 14 St.  
New York, N.Y. 10003

## F

Fame Recording  
1740 S. Bellevue  
Memphis, Tenn. 38114

Fame Recording Studios  
603 E. Avalon Ave.  
Muscle Shoals, Ala. 35660

Fanfare Recording Studios  
120 E. Main St.  
El Cajon, Calif. 92020

Fedco Audio Labs.  
37 Clarendon Ave.  
Providence, R.I. 02906

Fidelity Recording Studios  
6315 Yucca  
Hollywood, Calif.

Film Assocs. Inc.  
4600 S. Dixie Highway  
Dayton, Ohio 45439

Film City  
6087 Sunset Blvd.  
Hollywood, Calif.

Fine Recording Co., Inc.  
118 West 57th St.  
New York, N.Y.

Fink-Pinewood Recs. Inc.  
2732 Beachmont Ave.  
Norfolk, Va. 23504

Fleetwood Recording Co.  
321 Revere St.  
Revere, Mass. 02150

Fletcher Smith  
3141 SW 22nd Ct.  
Fort Lauderdale, Fla. 33312

Fortune Recordings  
3942 3rd Ave.  
Detroit, Mich.

Frank Brock Productions  
928 N. Youk  
Muskogee, Okla. 74401

Frankford/Wayne Recording Labs  
212 N. 12th St.  
Philadelphia, Pa. 19107

Fred Arthur Productions  
1218 E. 18th St.  
Denver, Colorado 80218

Fred Foxx Music Co.  
15 Ontario  
San Mateo, Calif. 94401  
Fredlo Recording Studios  
2224 E. 12th St.  
Davenport, Iowa 52803

Free Sound Recording Co.  
7604 S. Cottage Grove  
Chicago, Ill. 60619

Fremerman Rec'g & Tape Duplicating  
4041 Central  
Kansas City, Mo. 64111

Full Fidelity Recording  
9745 Lockland Rd.  
Cincinnati, Ohio 45215

## G

G&G Recording Service  
12 Lake Rd.  
Peekskill, N.Y. 10566

Gambit Enterprizes  
690 Monterey Blvd.  
San Francisco, Calif. 94127

Garland Recording  
565 Rose St. NE  
Salem, Oregon 97301

Gateway Assoc'd  
256 Fifth Ave.  
Pittsburg, Pa. 15222

Gaynote Recording  
4809 W. Adams Blvd.  
Los Angeles, Calif. 90016

General Audio Services  
308 W. Sixth St.  
Austin, Texas 78701

Gigantic Recording Studios  
113 Garfield Ave.  
Evansville, Ind. 47710

Gilfoy Recording Service  
300 Gilbert  
Bloomington, Ind. 47401

Glen Gleen Sound  
6624 Romaine St.  
Hollywood, Calif. 90038

Glo-Lite Recording Studio  
4081 Jackson  
Memphis, Tenn. 38128

Globe Recording Studio  
420 A Broadway  
Nashville, Tenn.

G M Recording  
14611 Nine Mile Road  
East Detroit, Mich. 48021

GMC Custom Recording Studio  
1595 Broadway  
New York, N.Y. 10019

Golden Echo Rec'g  
4720 N Mayflower Dr.  
Appleton, Wis. 54911

Golden State Recorders  
665 Harrison St.  
San Francisco, Calif.

Gotham Rec. Corp.  
2 West 46th St.  
New York, N.Y. 10036

G R S Recordings  
PO Box 801  
Springfield, Mo. 65801

Graves Recording Service  
2646 Willamette  
Eugene, Oregon 97405

Groove Sound  
240 W. 55 St.  
New York, N.Y. 10019

## H

Haka Productions  
3612 Tecumseh  
Lansing, Mich. 48906

Hanf Recording  
1825 Sylvania Ave.  
Toledo, Ohio 43613

Hardman Assocs., Inc.  
213 Smithfield St.  
Pittsburgh, Pa. 15222

Harmonic Sounds, Inc.  
1482 Felix Dr.  
Columbus, Ohio 43207

Harmony Recorders  
5611 Melrose Ave.  
Los Angeles, Calif.

Hickory Records  
25-10 Franklin Rd.  
Nashville, Tenn.

High Fidelity Recording  
1059 Porter  
Wichita, Kansas 67208

Hit Factory  
701 Seventh Ave.  
New York, N.Y. 10036

H M R Prod'ns  
574 West Ct.  
Scotch Plains, N.J. 07076

Hollywood Picture Recorders  
6367 Selma Ave.  
Hollywood, Calif. 90028

Howell Recording  
2703 Delaware Ave.  
Buffalo, N.Y. 14216

Hurricane Recording  
PO Box 3547  
Albuquerque, N.M. 87110

## I

I D Sound Studios  
1556 N. La Brea  
Hollywood, Calif. 90028

Ideal Recording  
119 S. Sam Houston  
San Benito, Texas 78586

Impact  
7101½ Castor Ave.  
Philadelphia, Pa. 19149

Indy Recording Studio  
3462 W. 16th St.  
Indianapolis, Ind. 46222

Infal Recorders  
2144 Champa St.  
Denver, Colorado 80202

International Recording  
49 Desmond Ave.  
Bronxville, N.Y. 10708

International Recording  
1649 W. Evergreen  
Chicago, Ill.

## WALLY HEIDER RECORDING

1604 N. Cahuenga Blvd.  
Hollywood, Calif.  
and  
245 Hyde Street  
San Francisco, Calif. 94102  
(415) 771-5780

## WHITNEY RECORDING STUDIOS, INC.

1516 W. GLEN OAKS BLVD.  
GLENDALE, CALIF. 91201  
245-6801

16 TRACK RECORDING SPECIALIST;  
REEL TO REEL AND  
CASSETTE DUPLICATING

McCann-Erickson: Esso/Enco—Eastern Air Lines—Coke  
Doyle, Dane & Bernbach: General Telephone  
B B D & O: Pepsi—V-8

Jay & the Americans, Anthony & the Imperials, Bobby Goldsboro,  
Orpheus and many, many more.

**Award winning commercials and hit records  
are made here.**

**WHY? BECAUSE WE ARE PROFESSIONALS!**

## MAYFAIR RECORDING STUDIOS, INC.

701 Seventh Avenue New York, N.Y. 10036 (212) LT 1-2178

(Cont. on next page)

# DEPOSIT ALL YOUR CUSTOM NEEDS HERE

... AND YOU'LL RECEIVE THE SAME INTEREST OUR OTHER STARS DO.

Recording

Re-mixing

Editing

Record and  
Tape Mastering

Record Pressing

Tape Duplication

Labeling and  
Packaging



Recording facilities in Hollywood and New York. Manufacturing plants in Los Angeles, Calif., Winchester, Virginia, Jacksonville, Ill., and Scranton, Pa.

For more information call (213) 462-6252 or write:  
Mr. Robert Sheehy, Custom Services Sales Manager,  
1750 N. Vine, Hollywood, Calif. 90028.



CUSTOM PRODUCTS

# Recording Studios

International Recording Studio  
3065 Choctaw  
Baton Rouge, La. 70805

Iowa Great Lakes Recording Co.  
906 Ninth St.  
Milford, Iowa 51351

**J**  
Jack Clement Recording Studio  
3102 Belmont Blvd.  
Nashville, Tenn. 37212

Jackson Sound Productions  
1401 S. Lipan  
Denver, Colorado 80223

Jackson Sound Studio  
P O Box 1037  
Jackson, Miss. 39205

Jaggars Audio Productions  
1804 S. Johnson St.  
Little Rock, Ark. 72204

Jatco  
3729 Virginia Rd.  
Los Angeles, Calif. 90016

Jaysina Ent.  
143 W. 51 St.  
New York, N.Y. 10019

Jewel Recording Studio  
1594 Kinney Ave.  
Cincinnati, Ohio 45231

Jimmy Fowler Productions  
1811 Stratford Rd.  
Cayce, S.C. 29033

J N R Recording Studios  
P O Box 130, Hollow Rd.  
Clinton Corner, N.Y. 12514

John Wagner Productions  
202 Wisconsin NE  
Albuquerque, N.M. 87108

JT Sound Studios  
166 Avenue A  
New York, N.Y. 10009

Juggy Sound Center  
265 W. 54 St.  
New York, N.Y. 10018

**K**  
Kaleidoscope/Studio One  
1500 Dixwell Ave.  
Hamden, Conn. 06514

Karrleton Ents. Ltd.  
805 W Ninth St.  
Marion, Ind. 52302

Kaytown Sound Productions  
PO Box 1208  
Kansas City, Kansas 66101

Ken-Del Studios  
111 Valley Road  
Richardson Park, Wilmington, Del. 19804

Kennett Sound Studio  
Hwy VV  
Kennett, Mo. 63857

Kin-Tel Productions & Sound Studios  
1200 Spring St. NW  
Atlanta, Ga. 30309

King's Recording Service  
314 S. Illinois St.  
Springfield, Ill. 62703

Kruz Recording  
617 Stendhal Lane  
San Jose, Calif. 95129

**L**  
L&F Recording Service  
1812 Procter  
Port Arthur, Texas 77640

L&H Sound Recording  
6027 Crescent Blvd.  
Pennsauken, N.J. 08109

La Louisianne  
711 Stevenson  
Lafayette, La. 70501

Laddie's Recording Enterprises  
1105 E. St. Charles Rd.  
Lombard, Ill. 60148

Laird Productions  
412 N. Second St.  
Harrisburg, Pa. 17105

Landen Magnetic Sound  
4465 E. 131 St.  
Garfield Heights, Ohio 44105

Lansing Recs.  
268 Old Windsor Rd.  
Dalton, Mass. 01226

Lariam Assoc. Inc.  
515 28th St.  
Des Moines, Iowa 50312

Larrabee Sound  
8811 Santa Monica  
Los Angeles, Calif. 90069

LeFevre Sound Corp.  
1314 Ellsworth Industrial Dr. NW  
Atlanta, Ga. 30318

Lemco Sound Studio  
2518 Southview Dr.  
Lexington, Ky. 40503

(Con't. on next page)

# FERRANTE & TEICHER

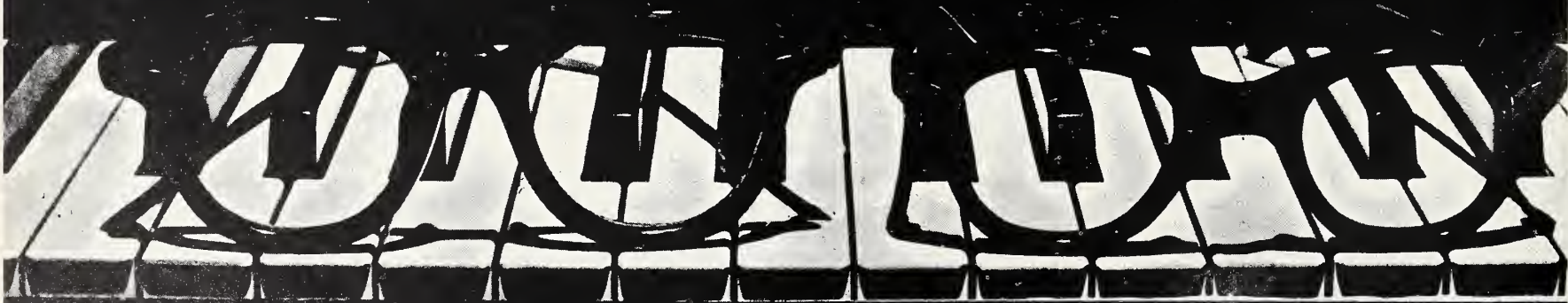

**MOST PROGRAMMED INSTRUMENTALISTS**

(1970 Cash Box Disk Jockey Poll)

Produced By George Butler

United Artists Records

# Feliciano never fails to ignite.

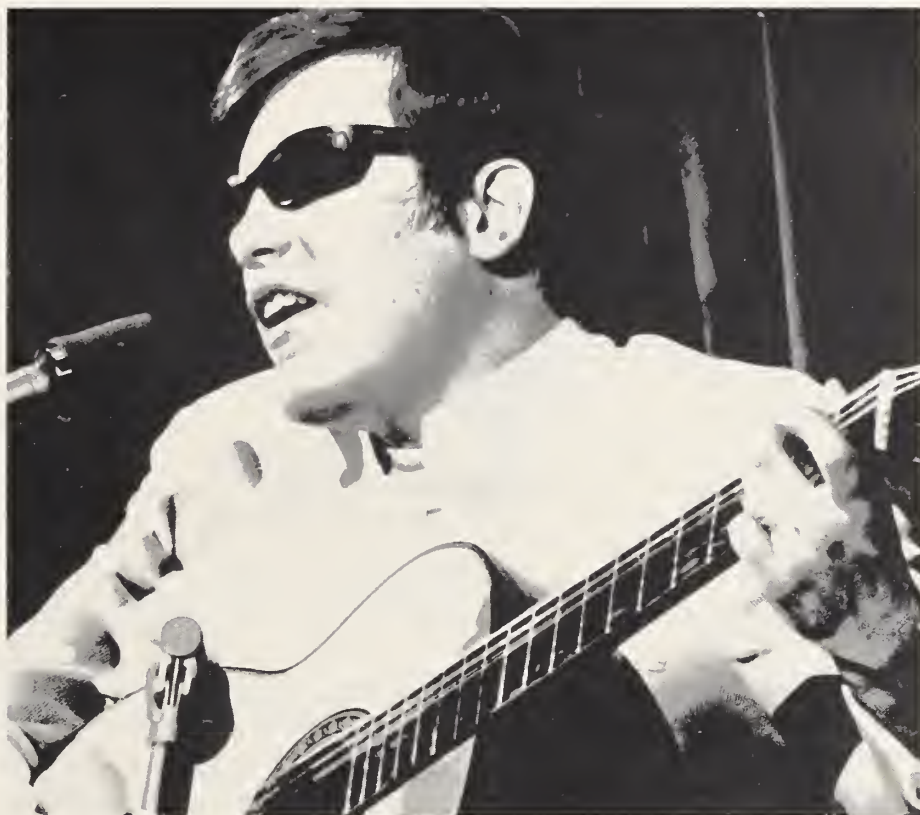

LSP-4370, P8S-1595, PK-1595

LSP-4185, P8S-1479, PK-1479



LSP-6021, P8S-1537/1538,  
PK-1537/1538

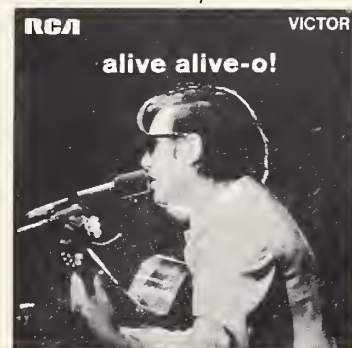

Features the two-sided hit  
"Destiny" w/ "Susie Q" 74-0358



**RCA** Records  
and Tapes

# Recording Studios

Liberty/UA Recording Studios  
8715 W. 3rd St.  
Los Angeles, Calif. 90048

Lifetime Recording  
133 North St.  
Rochester, N.Y. 14604

Lion Recording Services  
1905 Fairview Ave NE  
Washington, D.C. 20002

Living Sound Recorders  
146 W. Live Oak  
Arcadia, Calif. 91006

Location Recorders, Inc.  
429 W. 46 St.  
New York, N.Y. 10036

Location Recording Service  
2201 W. Burbank  
Burbank, Calif.

London House Recs.  
1064 Bergen St.  
Newark, N.J. 07108

Lou Neita Recording Co.  
3757 Main St.  
College Park, Atlanta, Ga. 30337

Lyn-Lou Music Inc.  
1518 Chelsea  
Memphis, Tenn. 38108

## M

M.B.S. Recording Studios  
228 S. Wabash  
Chicago, Ill.

Magnesonic Recording, Inc.  
1680 N. Vine  
Hollywood, Calif. 90028

Magnetic Studios  
1670 W. First Ave.  
Columbus, Ohio 43212

Major Recording Studio  
PO Box 2072  
Waynesboro, Va. 22980

Malaco Sound Recording  
3023 W. Northside Dr.  
Jackson, Miss. 35213

Marjon Recs.  
149 E. State St.  
Sharon, Pa. 16146

Mark Custom Rec.  
1518 S. Seventh St.  
Moorhead, Minn. 56560

Mark Educational Recorders  
2543 Raintree Drive NE  
Atlanta, Ga. 30329

Mark Recordings Of Missouri  
1220 Jake Lane  
Columbia, Mo. 65201

Mark V  
10 Michael Drive  
Greenville, S.C. 29610

Master Recorders  
244 Tunxis Ave.  
Bloomfield, Conn. 06002

Master Sound Studios Inc.  
1224 Fernwood Circle, N.E.  
Atlanta, Georgia 30319

Mastercraft Recording Corp.  
1269 Madison Ave.  
Memphis, Tenn. 38104

Mastertone Recording Studios  
130 W. 42nd St.  
New York 36, N.Y.

Mayfair Recording  
701 Seventh Ave.  
New York, N.Y. 10036

McCoy Recording Co.  
7018 W. Warren  
Detroit, Mich. 48210

McCune Sound Studios  
915 Howard St.  
San Francisco, Calif. 94103

C. P. McGregor  
729 So. Western  
Los Angeles, Calif.

Media Sound, Inc.  
311 W. 57 St.  
New York, N.Y. 10019

Melody Recording Studio  
1912 St. Clair St.  
Hamilton, Ohio 45011

Mercury Custom Recording Studios  
1512 Hawkins St.  
Nashville, Tenn. 37012

Mercury Sound Studios  
110 W. 57 St.  
New York, N.Y. 10019

Mercury Sound Studios  
1340 Mission St.  
San Francisco, Calif. 94103

Metropolitan Recording  
1828 E. Newberry Blvd.  
Milwaukee, Wis. 53211

Midnite Sound Studios  
West Ross Lane  
Danville, Ill. 61832

Midway Recording Studio  
3702 Ta Teays Valley Rd.  
Hurricane, W. Va. 25526

Mills Audio And Recording  
5960 Dueber Ave.  
East Sparta, Ohio 44626

Mirasound Studio  
353 W. 57th St.  
New York, N.Y.

Mo Do  
50 Orange St.  
Buffalo, N.Y. 14204

Monument Recording Studios  
114 17th Ave. S.  
Nashville, Tenn. 37203

Muscle Shoals Sound Studios  
3614 Jackson Highway  
Muscle Shoals, Ala. 35660

Music Factory, Inc.  
567 NW 27 St.  
Miami, Fla. 33127

Music Mountain Productions  
Lebanon Junction, Kentucky 40150

Music World Recording Studios  
Rt. 2 Overland Dr.  
West Columbia, S.C. 29169

Mutt Rec. Productions, Inc.  
27316 Michigan Ave.  
Inkster, Mich. 48141

## N

N A M Studios  
572 Lyell Ave.  
Rochester, N.Y. 14606

Nashville Rec. Prod'ns  
905 17 Ave. S.  
Nashville, Tenn. 37212

Nashville Recording Services  
1703 Church St.  
Nashville, Tenn. 37203

Nashville Sound Inc.  
9717 Jensen  
Houston, Texas 77016

National Guild Recording Studio  
Rt. 15A and Grayson St.  
Orange City, Fla. 32763

National Recording  
730 Fifth Ave.  
New York, N.Y. 10019

Natural Sound  
63 Main St.  
Maynard, Mass. 01754

Nemo Recording Labs  
181 River Rd.  
Nutley, N.J. 07110

New London Recording Center  
1817 Oxmoor Rd.  
Birmingham, Ala. 35209

Newcomb Recording Studio  
4834 Bissell Ave.  
Richmond, Calif. 94805

Nine Nineteen Sound Studios  
919 N. Broad St.  
Philadelphia, Pa. 19123

Nise Productions, Inc.  
1718 Roselyn St.  
Philadelphia, Pa. 19141

Nola Studios  
111 W. 57th St.  
New York, N.Y.

Norfolk Recording Studio  
622 W. 35 St.  
Norfolk, Va. 23508

Norm Vincent Assoc. Inc.  
4551 Brown Ave.  
Jacksonville, Fla. 33207

Nugget Studios  
400 Tinnin Rd.  
Nashville, Tenn.

## O

Oakland Recording Studio  
638 S. 24th St.  
Lafayette, Ind. 47904

Oakridge Recording  
2001 Elton Rd.  
Fort Worth, Texas 76117

Ohmit Recording Studio  
6102 E. 10th St.  
Indianapolis, Ind. 46219

Olmsted Sound Studios, Inc.  
80 W 40th St.  
New York, N.Y.

OmniVisual  
2722 S. MacDill Ave.  
Tampa, Fla. 33609

Orbit Radio  
831 W. Main  
Louisville, Ky.

## P

Pac 3 Recording Co.  
7106 Greenfield  
Dearborn, Mich. 48126

Pacific High Recording Co.  
60 Brady St.  
San Francisco, Calif. 94103

Pacific Recording  
1737 El Camino S.  
San Mateo, Calif. 94402

Paramount Recording Studio  
6245 Santa Monica  
Los Angeles, Calif. 90038

Parasound Inc.  
2825 Hyans St.  
Hollywood, Calif. 90026

(Cont'n on next Page)

*Alex Hassilev*  
Studios

Electronic Music—  
Custom Recording  
Reasonable Rates

Complete 8 Track Facilities—  
4 Echo Chambers Pot Pans—  
Moog Synthesizer—Dolby System  
—V S O—Yamaha E-3 Organ—  
Baldwin Grand.

**CREATIVE  
PRODUCTION SERVICES**

8610 West Knoll Drive  
Los Angeles, Calif. 90069  
652-2092



# THE CASH BOX 1970 DISC JOCKEY POLL WINNERS

*WILL BE PRESENTED ON*

S  
C  
E  
N  
E

# 70

THE #1 SYNDICATED MUSIC SHOW

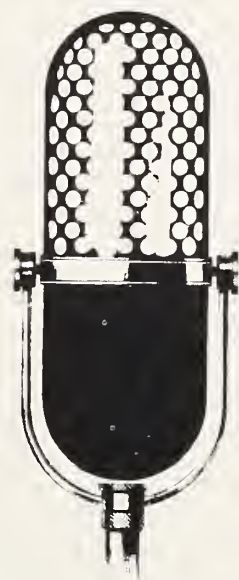

Trophies By:  
**MICHAEL C. FINA**

**TOM JONES**  
**ELVIS PRESLEY**  
Most Programmed Male Vocalist

**DIONNE WARWICK**  
Most Programmed Female Vocalist

**BEATLES**  
Most Programmed Vocal Group

**HENRY MANCINI**  
Most Programmed Orchestra

**FERRANTE & TEICHER**  
Most Programmed Instrumentalist

**JOE COCKER**  
Most Promising Male Vocalist

**MELANIE**  
Most Promising Female Vocalist

**JACKSON FIVE**  
**CHICAGO**  
Most Promising Vocal Group

**VINCENT BELL**  
Most Promising Orchestra

**EL CHICANO**  
Most Promising Instrumentalist

**"SUGAR SUGAR" ARCHIES-KIRSHNER**  
Most Programmed Single

**ABBEY ROAD-BEATLES-APPLE**  
Most Programmed Album

S  
C  
E  
N  
E

# 70

300 West 55th Street; New York, N. Y.; (212) 265-4358

Syndicated by: Broadcasters, Television System, Inc.  
1010 Euclid Ave., Cleveland, Ohio (216) 781-3600

# Recording Studios

Petrucci & Atwell  
331 Newbury St.  
Newton, Mass 02115

Pharaoh Records  
P.O. Box 969  
McAllen, Texas

Phoenix Sound Recording Studio  
3703 N. 7th St.  
Phoenix, Ariz. 85014

Pioneer Recording Studio  
20014 James Couzens  
Detroit, Mich. 48235

Posthorn Recordings  
185 Avenue C  
New York, N.Y. 10009

Praise Recordings  
15889 Freed St. SE  
Minerva, Ohio 44657

Process Rec. Co.  
439 Wiley Ave.  
Franklin, Pa. 16323

Program Services, Inc.  
215 W. Chicago Ave.  
Chicago, Ill. 60610

Project 70 Sound Studios  
2080 Peachtree Industrial Ct.  
Chamblee, Ga. 30341

## Q

Quality Recording Service  
1010 N. Wilson Way  
Stockton, Calif. 95205

Queen of Sound  
1314 Pine St.  
Nashville, Tenn. 37203

Quinvy Music Corp.  
1307 Broadway  
Muscle Shoals, Ala. 35660

## R

Radio Recorders  
7000 Santa Monica Blvd.  
Hollywood, Calif.

R-C Sound Studios  
50 Plainfield Ave.  
Metuchen, N.J. 08840

RCA Custom Record Sales  
1133 Ave. of Americas  
New York, N.Y. 10036  
(212) 586-3000

RCA Custom Record Sales  
800 17th Ave. S.  
Nashville, Tenn. 37203  
(615) 255-5781

RCA Custom Record Sales  
6363 Sunset Blvd.  
Hollywood, Calif. 90028  
(213) 461-9171

RCA Custom Sales  
1 N. Wacker Drive  
Chicago, Ill.  
(312) 944-3215

Record Plant  
321 W. 44 St.  
New York, N.Y. 10036

Record Plant West  
8456 West 3rd St.  
Los Angeles, Calif.

Recorded Publ'ns Labs  
1558 Pierce Ave.  
Camden, N.J. 08105

Recording Studios, Inc.  
212 W. 48 St.  
New York, N.Y. 10036

Red Flame Recs. & Rec'g Studios  
PO Box 563  
Kirkville, Mo. 63501

Reeves Sound Studios, Inc.  
304 E. 44th St.  
New York, N.Y.

Regent Sound Studios  
25 W. 56th St.  
New York, N.Y.

Reice Hamel Recording USA  
5120 Hyde Park Blvd.  
Chicago, Ill. 60615

Rex Recording Co.  
931 S.W. King  
Portland, Ore. 97205

Richcraft Recording  
1706 Flatbush Ave.  
Brooklyn, N.Y.

Richmond Sound States  
2314 W. Cary St.  
Richmond, Va. 23220

Ripcord Rec'g Co.  
PO Box 2098  
Vancouver, Wash. 98863

RKO Sound  
1440 Broadway  
New York, N.Y. 10018

Ro Fran Ent.  
117 W. Washington  
Urbana, Ill. 61801

Rocky Mountain Recording  
PO Box 82  
Cheyenne, Wyoming 82001

Ron Sound  
PO Box 3762  
Cocoa, Fla. 32922

Ron Stancil Productions  
PO Box 11615  
St. Petersburg, Fla. 33733

Ron Wheeler Ent.  
4788 Connecticut  
Gary, Ind. 46409

Rosemont Recording Studio  
4634 Wilson Ave.  
New Orleans, La. 70126

Rossi Ent.  
2005 W. 8th St.  
Brooklyn 23, N.Y.

Roto Recs.  
2650 N. 48 St.  
Lincoln, Neb. 68504

Royal Recording Studio  
1320 S. Lauderdale  
Memphis, Tenn. 38106

## S

Sage & Sand Recording  
6520 Selma Ave.  
Hollywood, Calif. 90028

Sanders Rec. Studios, Inc.  
167 W. 48th St.  
New York, N.Y.

Sandonna Productions, Inc.  
8265 Kennedy Blvd.  
Jersey City, N.J. 07306

Sara Sound Studios, Inc.  
123 Water St.  
Sauk City, Wis. 53583

Scepter Recording Studios  
254 W. 54 St.  
New York, N.Y. 10019

Scott Productions  
PO Box 685  
Eau Claire, Wis. 54701

Seattle West Rec'g Corp.  
319 N. 85 St.  
Seattle, Wash. 98103

Select Sound Studio  
1790 Broadway  
New York, N.Y. 10019

Park Recording  
200 E. 66th St.  
New York, N.Y.

Parliament Studio  
4005 W. Washington Blvd.  
Chicago, Ill. 60624

Paul Hayes Productions  
1734 Central Ave.  
St. Petersburg, Fla. 33705

Persuasion Systems  
15 E. Pearson St.  
Chicago, Ill. 60611

Tel: 516-485-5066

# ULTRA-SONIC

## RECORDING STUDIOS, INC.

100 North Franklin Street  
Hempstead New York, 11550

(Con't on next Page)

**Thank You-Everyone!**

**Blues Image**



Larry Larson-Todd Schiffman  
19000 Sunset Blvd.  
Los Angeles, Calif. 90069  
(213) 278-8216



**WATCH OUT WORLD,  
THE LION'S LOOSE!**

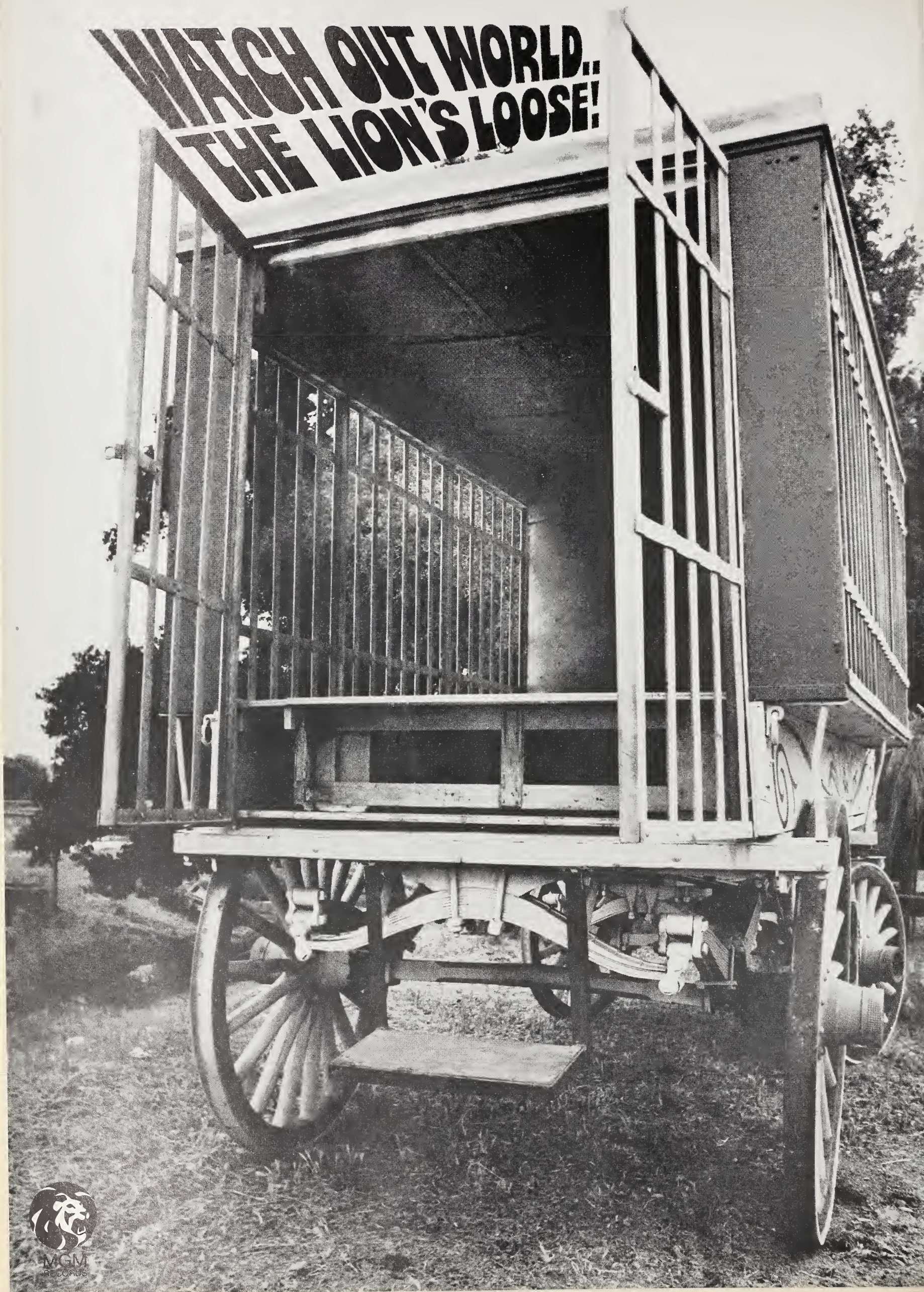

# Recording Studios

Sound Center, Inc.  
750 Eighth Ave.  
New York, N.Y. 10036

Sound/City  
3316 Line Ave.  
Shreveport, La. 71104

Sound City Inc.  
15456 Cabrito Rd.  
Van Nuys, Calif. 91406

Sound City Recording  
210 Gordon St.  
Jackson, Tenn. 38310

Sound 80 Inc.  
4444 W. 76 St.  
Minneapolis, Minn. 55435

Sound Exchange  
265 W. 54 St.  
New York, N.Y. 10019

Sound Factory Inc.  
6357 Selma Ave.  
Los Angeles, Calif. 90028

Sound Genesis  
759 Harrison St.  
San Francisco, Calif. 94107

Sound Ideas Studio  
1595 Broadway  
New York, N.Y. 10019

Sound Inc.  
56880 North Ave.  
New Haven, Mich. 48048

Sound Recorders  
206 S. 44th  
Omaha, Neb. 68131

Sound Recorders Studio  
6226 Yucca  
Hollywood, Calif. 90028

Sound Stage One  
334 N. Ontare Rd.  
Santa Barbara, Calif. 93105

Sound Studios  
230 N. Michigan  
Chicago, Ill.

Sound—Unlimited  
1550 Market  
San Francisco, Calif. 94102

Soundings Recording Service  
215 E. 12th St.  
New York, N.Y.

Sounds Of Memphis, Inc.  
904 Rayner St.  
Memphis, Tenn. 38114

Soundview Studios  
132 Riviera Dr.  
Kings Park, N.Y. 11754

Soundville  
8208 Westpark Dr.  
Houston, Texas 77042

Soundwave Studios, Inc.  
50 W. 57 St.  
New York, N.Y. 10019

Spar Recording  
110 21st Ave. S.  
Nashville, Tenn. 37203

Stage III Sound Productions  
12 E. 39th St.  
Kansas City, Mo. 64111

Stereophonics Corp.  
403 Rivet St.  
New Bedford, Mass. 02744

(Con't on next Page)

Sellers Co. Recording Studio  
2102 Jackson  
Dallas, Texas 75201

Shadow Recording, Inc.  
790 NE 45th St.  
Fort Lauderdale, Fla. 33308

Shelby Singleton Sound Studios  
3106 Belmont Blvd.  
Nashville, Tenn. 37212

Sierra Sound Labs  
1741 Alcatraz Ave.  
Berkeley, Calif. 94703

Sidewalk Sound Recorders  
(Div. of Sidewalk Prod., Inc.)  
Hollywood, Calif.

Sigma Sound Studios  
212 N. 12 St.  
Philadelphia, Pa. 19107

6 West Recording  
6 W. 57 St.  
New York, N.Y. 10019

Sleeping Giant Films, Inc.  
3019 Dixwell Ave.  
Hamden, Conn. 06518

Sonic Recording  
1230 W. Washington  
Chicago, Ill.

Sonic Recording Studio  
1692 Madison Ave.  
Memphis, Tenn. 38104

Sonic Services  
1824 Shady Lane  
Louisville, Ky. 40205

Sound-Art Studios, Inc.  
135 Day St.  
Newington, Conn. 06111

Sound Assocs.  
1212 Edith NE  
Grand Rapids, Mich. 49505

Sound By St. James  
699 Jericho Turnpike  
St. James, L.I., N.Y. 11780



**BROADWAY RECORDING STUDIOS**  
A DIVISION OF TRANS NATIONAL COMMUNICATIONS INC.

1697 Broadway, N.Y.,  
N.Y. 10019  
Tel: (212) CI 7-1690

# The Sound Of Ireland THE CLANCY BROS. In Concert

Exclusive Representation  
JERRY B. CAMPBELL MANAGEMENT, INC.  
3 East 65th Street, Apt. 1-C  
New York, N.Y. 10021 (212) 249-2988

## Recording Studios

**Stereo-Sonic**  
528 N. Michigan  
Chicago, Ill.

**Stereo Sound Studios**  
238 E. 26th St.  
New York, N.Y.

**Sterling Sound, Inc.**  
56 W. 45 St.  
New York, N.Y. 10036

**Steve Wright Recording Studio**  
PO Box 626  
Tyler, Texas 75701

**Streeterville Studios, Inc.**  
161 E. Grand  
Chicago, Ill. 60611

**Studio B Recording Studio**  
1316 N. Chaparral  
Corpus Christi, Texas 78401

**Studio Center**  
200 W. 22 St.  
Norfolk, Va. 23517

**Studio 7**  
PO Box 57  
Smith, Ala. 36877

**Studio 10**  
10 Claude Lane  
San Francisco, Calif. 94108

**Summit**  
1130 W. Evans  
Denver, Colorado 80223

**Sunset Sound Recorders**  
6650 Sunset Blvd.  
Los Angeles, Calif.

**Sun-Ray**  
1662 Weyatt Pkway.  
Lexington, Ky. 40505

**Sun West Recording Studio**  
5539 Sunset Blvd.  
Los Angeles, Calif. 90028

**Super Sound Studios**  
6478 Santa Monica  
Hollywood, Calif. 90038

**Surf Recording**  
544 Rhode Island Ave.  
Bricktown, N.J. 08723

**Syncron Sound Studios, Inc.**  
10 George St.  
Wallingford, Conn. 06492

**T**  
**T.A. Recording Studio**  
654 River Dr.  
Garfield, N.J. 07026

**Technisonic Studios**  
1201 S. Brentwood Blvd.  
St. Louis, Mo. 63131

**Television Productions Int'l**  
1374 West Peachtree St. NE  
Atlanta, Ga. 30309

**Ter-Mar Recording Studios**  
2030 S. Calumet  
Chicago 16, Ill.

**Texas Sound Studios**  
506 W. Hildebrand Ave.  
San Antonio 12, Texas

**Theatre Editing Studios Inc.**  
505 Eighth Ave.  
New York, N.Y. 10018

**Thomas Zoss Productions**  
1255 E. Madison  
South Bend, Ind. 46624

**Thunder Recording**  
PO Box 271  
Jenkintown, Pa. 19046

**Tiki Sound Studio**  
792 E. Julian St.  
San Jose, Calif. 95112

**Top Talent Sound of Springfield**  
1763 E. Elm  
Springfield, Mo. 65804

**Totalsound**  
4504 Belmont  
Dallas, Texas 75204

**Triangle Sound Inc.**  
1129 S. Green  
Tupelo, Miss. 38801

**Tri Con Productions**  
2741 34 34 St. NW  
Washington, D.C. 20008

**Trout Audio Labs.**  
1784 San Gabriel Dr.  
York, Pa. 17402

**True Tone Rec. Co.**  
160 W. 73rd St.  
Studio 4-F  
New York, N.Y.

**Twelve East Recording**  
12 E. 44 St.  
New York, N.Y. 10017

**Tyler Recording Studios**  
5 West Hubbard St.  
Chicago, Ill. 60610

**U**  
**UA Recording**  
2541 Nicollet Ave. S.  
Minneapolis, Minn. 55404

**Ultra-Sonic Recording**  
100 N. Franklin St.  
Hempstead, N.Y. 11550

**United Audio Corp.**  
1519 S. Grand Ave.  
Santa Ave. Calif. 92705

**United Audio Recording**  
10 Ellenwood Ave.  
Youngstown, Ohio 44507

**United Sound Systems, Inc.**  
5840 Second Ave.  
Detroit, Mich. 48202

**Universal Audio Recording**  
115 W. 4th St.  
Winona, Minn. 55987

**Universal Promos**  
1101 S. Ninth St.  
Omaha, Neb. 68106

**Universal Recording**  
46 E. Walton  
Chicago, Ill.

**Universal Recording Studios**  
247 Chelsea Ave.  
Memphis, Tenn. 38107

**Universal Recording Studios**  
26 Colton Ave.  
West Springfield, Mass. 01089

**V**  
**Valley Productions**  
Box 3464  
Knoxville, Tenn. 37917

**Valtron Recording**  
305 Allen St.  
Helena, Mont. 59601

(Con't on next Page)

**VANGUARD** has the console *to the studio!*

24 inputs, 16 output groups.  
Complete 16 track recording and mix-down facilities,  
in New York's most complete and sound-perfect recording studio.

(P.S. It's beautifully comfortable  
to work in and big  
enough for  
a major orchestra)

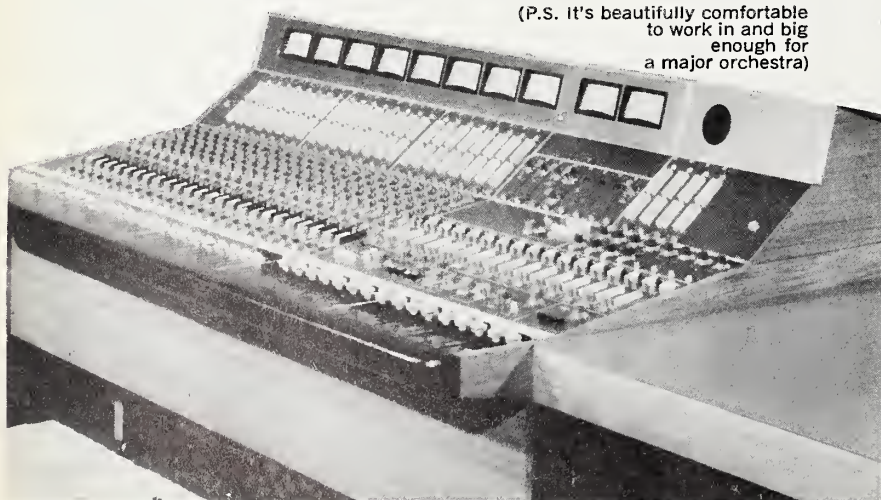

FOR BOOKING INFO: CALL PAT GOERKE (212) AL 5-7732  
Vanguard Records, 71 West 23rd Street, New York, N.Y. 10010

## Recording Studios

Vanguard Productions  
8 Winter St.  
Brattleboro, Vt. 05301

Vanguard Recs.  
71 W. 23 St.  
New York, N.Y. 10010

Variety Recording  
130 W. 42nd St.  
New York 36, N.Y.

Varsity  
1703 Church St.  
Nashville, Tenn. 37203

Vault Recording Studio  
2525 W. 9th St.  
Los Angeles, Calif. 9606

Village Recorder  
1616 Butler Ave.  
West Los Angeles, Calif. 90025

Virtue Recording Studio  
1618 N. Broad St.  
Philadelphia, Pa.

Voice Inc.  
5810 Flagler St.  
Miami, Fla. 33144

Wally Heider Recording  
6373 Selma Ave.  
Hollywood, Calif.

Wally Heider Recording  
245 Hyde Street  
San Francisco, Calif. 94102

Waverley Recording Studio  
24 Carroll St.  
Watertown, Mass. 02172

Way Out Recordings  
1966 E. 55 St.  
Cleveland, Ohio 44103

Webb Recs.  
1234 Luther St.  
Emporia, Kansas 66801

Western Cine Service  
312 S. Pearl St.  
Denver, Colorado 80209

Western Recorders  
6000 Sunset Blvd.  
Hollywood, Calif.

Westex Recording Studio  
PO Box 6406  
Odessa, Texas 79760

W F Music Ents.  
19011 Riverview  
Detroit, Mich. 48219

WG Recording Studio  
66 Elmwood Ave.  
Holyoke, Mass. 01040

Whitney Recording Studio  
1516 W. Glenoaks Blvd.  
Glendale, Calif. 91201

Wiley Sound Studio  
5103 N. 46 St.  
Spokane, Wash. 98407

Woodland Sound Studio  
1001 Woodland St.  
Nashville, Tenn. 37206

Wooten Recording Co.  
3373 Park Ave.  
Memphis, Tenn. 38111  
W R S Recording Studio  
210 Semple St.  
Pittsburgh, Pa. 15213

Wright Recordings  
6460 N. Claremont  
Chicago, Ill. 60645

Yale Audio of Florida Corp.  
2732 Florida Ave.  
Tampa, Fla. 33602

Zenith Cinema Service  
3252 W. Foster Ave.  
Chicago, Ill. 60625

Zia Recording Studio  
814 19 Ave. S  
Nashville, Tenn. 37203

To Cash Box  
And All Our  
Friends In  
The Industry

**RING DING DING**

*Mario & Tony*

**MARTONI  
RESTAURANT**

1523 N. Cahuenga  
Hollywood, 90028

466-3441

**S**tereo  
onic RECORDING CORP.

*The Music Factory*

POPULAR MUSIC SPECIALISTS  
16-8-4-2-1 TRACK RECORDING  
COMPLETE DISC CUTTING FACILITIES  
HAMMOND ORGAN—STEINWAY PIANO  
CREATIVE ENGINEERING CONCEPTS

528 N. MICHIGAN AVE.  
CHICAGO, ILL. 60611  
(312) 527-2546

**Joe Gottfried,  
Joe Leahy  
and  
SOUND CITY**

express grateful appreciation  
to the many clients and friends  
who have made our first year  
so successful.

Thanks also from: Dale Batch-  
lor, Jim Brown, Jack Crymes,  
Bill Drescher, Mark Richard-  
son and Daniel Boone.

**SOUND CITY  
RECORDING STUDIOS**  
15456 Cabrito Road  
Van Nuys, California 91406  
(213) 873-2842—787-3722

*Thanks.*

*Percy Faith*

**SUBSCRIBE  
NOW TO  
CASH BOX!**



1970  
That Was  
A  
Very Good  
Year

**KENT RECORDS**

BRIGHT  
ORANGE

Modern

MODERN  
OLDIES 45's

Custom

CONTESSA

CROWN

MOTHER  
GOOSE

ROBIN  
HOOD

MODERN TAPE CORP.

FLAIR<sup>30</sup>

12 ORIGINAL  
ARTIST OLDIE HITS

FLAIR<sup>180</sup>

• Custom Record Mfg. •

Custom Tape Duplicators

4-TRACK / 8-TRACK / CASSETTE / OPEN REEL

DIVISIONS OF

**CADET RECORDS INC.**

5810 SO. NORMANDIE AVE., LOS ANGELES, CALIFORNIA 90044  
(213) 753-2481

**CUSTOM TAPE DUPLICATORS** (Con't. from page 160)

Educational Services  
P.O. Box 85  
Radnor 19807

Gateway Associated  
256 Fifth Ave.  
Pittsburgh, 15222

Hardman Associations Inc.  
213 Smithfield St.  
Pittsburgh, 15222

Helffrich Recording Labs  
East Texas Rd. West, RD 2  
Allentown, 18103

James K. Hodgkins  
405 N. Front St.  
Reading, 19601

Ladd Music Co.  
401 Wintermantle Ave.  
Scranton, 18505

Laird Productions Inc.  
412 N. Second St.  
Harrisburg, 17105

Marjon Records  
159 Easton Rd.  
Sharon, 16146

Process Record Co.  
439 Wiley Ave.  
Franklin 16323

Thunder Recording Studio  
Cedar & West Ave.  
Jenkintown, 19046

Trout Audio Labs  
1784 San Gabriel Dr.  
York, 17402

W R S Recording Studio  
210 Semple St.  
Pittsburgh, 15213

**RHODE ISLAND**

Fedco Audio Labs  
37 Clarendon Ave.  
Providence, 02906

**SOUTH CAROLINA**

Mark V.  
10 Michael Dr.  
Greenville, 29610

**TENNESSEE**

American Recording  
827 Thomas St.  
Memphis, 38107

Blackwood Recording Studio  
3933 Summer  
Memphis, 38122

Century Recording Service  
11 S. Idlewild  
Memphis, 38104

**VERMONT**

Vanguard Productions  
8 Winter St.  
Brattleboro, 05301

**VIRGINIA**

Norfolk Recording Studio  
622 W. 35 St.  
Norfolk, 23508

Richmond Sound Stages  
2314 W. Cary St.  
Richmond, 23220

Studio Center  
200 W. 22 St.  
Norfolk, 23517

**WASHINGTON**

Apollo Enterprises  
1915 N. Quince  
Olympia 98501

Wiley Sound Studio  
5103 N. 46 St.  
Tacoma, 98407

**WISCONSIN**

Dave Kennedy Recording Studios  
2755 N. Third St.  
Milwaukee, 53212

Sara Sound Studios Inc.  
123 Water St.  
Sauk City, 53583

**WYOMING**

Rocky Mountain Recording  
P.O. Box 82  
Cheyenne, 82001

*IF you are reading  
someone else's copy of*  
**Cash Box**  
*why not mail this coupon  
today!*

**CASH BOX**  
**1780 BROADWAY**  
**NEW YORK, N. Y. 10019**

Enclosed find my check.

- \$30 for a full year (52 weeks) subscription (United States, Canada, Mexico)
- \$50 for a full year (Airmail United States, Canada, Mexico)
- \$60 for a full year (Airmail other countries)
- \$40 for a full year (Steamer mail other countries)

(Check One)

- I AM A  
DEALER .....
- ONE STOP .....
- DISTRIB .....
- RACK JOBBER .....
- PUBLISHER .....
- RECORD CO .....
- DISK JOCKEY .....
- COIN FIRM .....
- OTHER .....

**NAME** .....

**FIRM** .....

**ADDRESS** .....

**CITY** ..... **STATE** ..... **ZIP #** .....

Be Sure To Check Business Classification Above!



# **OPPORTUNITIES UNLIMITED!**

## **PERFORMERS PERSONALITIES PRODUCERS PUBLISHERS**

Great future with a major company with solid sales and promotion—national and international—network. Parent company long-time leader in motion picture and TV production. Strong roster of top-selling artists in all fields. Truly a dazzling success story. Informal atmosphere. Good working conditions. Fringe benefits too numerous to mention. Come on in and let's talk...



**DECCA RECORDS**  
A Division of MCA Inc.

*publishers  
of the  
TOP  
100  
HITS*

**A**

Airfield—BMI  
1804 Ivar Ave.  
Los Angeles, Calif.

Alchemy—ASCAP  
9777 Wilshire Blvd.  
Los Angeles, Calif.

Algee—BMI  
101 W. 55 St.  
N.Y.C., N.Y.

Almo—ASCAP  
1416 N. LaBrea  
Los Angeles, Calif.

Alstein—BMI  
7514 Cottage Ave.  
Chicago, Ill.

Armestoy—BMI  
71-107 Fairway Drive  
Cathedral City, Calif.

Ampco—ASCAP  
1330 Ave. of Americas  
N.Y.C., N.Y.

Andante—ASCAP  
P.O. Box 1147  
Westhampton Beach, N.Y.

Andromeda—ASCAP  
1700 Broadway  
N.Y.C., N.Y.

Apple—ASCAP  
1700 Broadway  
N.Y.C., N.Y.

Arden—BMI  
185-01 140 Ave.  
Springfield Gardens, N.Y.

ARC—BMI  
1619 Broadway  
N.Y.C., N.Y.

Assorted—BMI  
c/o Gamble Huff  
250 S. Broad St.  
Philadelphia, Pa.

Atna—ASCAP

Aurelius—BMI  
10680 W. Pico Blvd.  
Los Angeles, Calif.

7781 Sunset Blvd.  
Los Angeles, Calif.

Attache—BMI  
9000 Sunset Blvd.  
Los Angeles, Calif.

**B**

Barnegat—BMI  
c/o UA  
729 7th Ave.  
N.Y.C., N.Y.

Back Bay—BMI  
10 E 44 St.  
N.Y.C., N.Y.

Earl Barton—BMI  
1121 S. Glenstone  
Springfield, Mo.

Beechwood—BMI  
1750 N. Vine  
Los Angeles, Calif.

Belwin Mills—ASCAP  
16 W. 61 St.  
N.Y.C., N.Y.

Bexhill—ASCAP  
15 W. 81 St.  
N.Y.C., N.Y.

Big 7—BMI  
17 W. 60 St.  
N.Y.C., N.Y.

Big Sky—ASCAP  
P.O. Box 27  
Prince St. Station  
N.Y.C., N.Y.

Binn—ASCAP  
257 Bayard Rd.  
Upper Darby, Pa.

Birdees—ASCAP  
1501 Broadway  
N.Y.C., N.Y.

Blackwood—BMI  
1650 Broadway  
N.Y.C., N.Y.  
P.O. Box 12398  
Nashville, Tenn.

Blendingwell—ASCAP  
40 W. 55 St.  
N.Y.C., N.Y.

Blimp—BMI  
8961 Sunset Blvd.  
Los Angeles, Calif.

Blue Book—BMI  
P.O. Box 2387  
Bakersfield, Calif.

Blue Crest—BMI  
P.O. Box 162  
Madison, Tenn.

Blue Seas—ASCAP  
c/o Fred E. Ahlert Jr.  
15 W. 48 St.  
N.Y.C., N.Y.

BnB—BMI  
P.O. Box 7816  
Detroit, Mich.

Bob-Cor—BMI  
c/o Mascari  
185 N. Wabash Ave.  
Chicago, Ill.

Boom—BMI  
250 N. Canon Drive  
Beverly Hills, Calif.

Bornwin—BMI  
300 W. 55 St.  
N.Y.C., N.Y.

Boone—BMI  
Box 200  
Des Moines, Iowa

Bourne—ASCAP  
136 W. 52 St.  
N.Y.C., N.Y.

BRC—BMI  
445 Park Ave.  
N.Y.C., N.Y.

Bridgeport—BMI  
c/o George Clinton  
14643 Joy Rd.  
Detroit, Michigan

Broadside—BMI  
c/o Steed  
729 7th Ave.  
N.Y.C., N.Y.

Broken Arrow—BMI  
449 S. Beverly Drive  
Beverly Hills, Calif.

Brother—BMI  
1654 N. Ivar Ave.  
Hollywood, Calif.

Budd—ASCAP  
1619 Broadway  
N.Y.C., N.Y.

Bullfighter—BMI  
c/o Royal American  
806 16th Ave. S.  
Nashville, Tenn.

Fred Burch—BMI  
3029 Creekwood Drive  
Nashville, Tenn.

Byron, Julio—BMI  
Judon BMI

**C**

Cachand—BMI  
1449 S. Michigan  
Chicago, Ill.

Canaan—ASCAP  
75 E. 55 St.  
N.Y.C., N.Y.

Cape Ann—BMI  
c/o J. R. Enterprises  
P.O. Box 6128  
Nashville, Tenn.

Casserole—BMI  
221 W. 57 St.  
N.Y.C., N.Y.

(Cont. on next page)

**M.R.C./THREE BRIDGES MUSIC, INC.**

110 West 57th Street  
New York, N. Y. 10019  
(212) 765-2563



6922 Hollywood Blvd.  
Hollywood, California 90028  
(213) 469-3937

*Best Wishes*

**Johnny Mercer Marshall Robbins**

**COMMANDER PUBLICATIONS**

1610 N. Argyle Ave.  
Hollywood, Calif. 90028  
(213) 469-3528

# CHAPPELL

**Worldwide Music Publishers Since 1811**

NEW YORK	LONDON
AMSTERDAM	MUNICH
BRUSSELS	NASHVILLE
HAMBURG	PARIS
JOHANNESBURG	STOCKHOLM
LOS ANGELES	SYDNEY
MADRID	TORONTO
MILAN	WELLINGTON
MONTREAL	ZURICH

Chappell & Co., Inc., 609 Fifth Avenue, New York 10017/Tel. (212)752-4300  
Chappell & Co., Ltd., 50 New Bond Street, London W. 1/Tel. 01-629 7600

*publishers  
of the  
TOP  
100  
HITS*

Cat Mother—BMI  
25 W. 56 St.  
N.Y.C., N.Y.

Canopy—ASCAP  
8979 Sunset Blvd.  
Los Angeles, Calif.

Cedarwood—BMI  
815 16th Ave. S.  
Nashville, Tenn.

Central—BMI  
1804 Ivar Ave.  
Hollywood, Calif.

Cents & Pence—BMI  
c/o TA  
4024 Radford Ave.  
Studio City, Calif.

Chappell Music—ASCAP  
609 5th Ave.  
N.Y.C., N.Y.

Charing Cross—BMI  
521 5th Ave.  
N.Y.C., N.Y.

Cherry Lane—ASCAP  
15 E. 48 St.  
N.Y.C., N.Y.

Chevis—BMI  
c/o Cadet  
320 E. 21st St.  
Chicago, Ill.

Chrysalis—ASCAP

Claridge & Tons of Fun—ASCAP  
6362 Hollywood Blvd.  
Hollywood, Calif.

Cocanut Grove—BMI  
5455 Wilshire Blvd.  
Los Angeles, Calif.

Colfam—BMI  
c/o Giant Enterprises  
8144 S. Cottage Grove  
Chicago, Ill.

Colo—BMI  
c/o King  
1580 Brewster Ave.  
Cincinnati, Ohio

Combine—BMI  
530 W. Main St.  
Hendersonville, Tenn.

Conrad—BMI  
1619 Broadway  
N.Y.C., N.Y.

Cool Water—ASCAP  
1060 Park Ave.  
N.Y.C., N.Y.

Cotillion—BMI  
1841 Broadway  
N.Y.C., N.Y.

Country Road—BMI

Mike Curb—BMI  
6331 Hollywood Blvd.  
Hollywood, Calif.

Curton—BMI  
8543 Stony Island Ave.  
Chicago, Ill.

**D**

Dakar—BMI  
2263 Spruce St.  
Philadelphia, Pa.

Daly City—BMI  
221 W. 57 St.  
N.Y.C., N.Y.

Dandelion—BMI  
c/o Jamie  
919 N. Broad St.  
Philadelphia, Pa.

Delbon—BMI  
8425 W. 3rd St.  
Los Angeles, Calif.

Detail—BMI  
729 7th Ave.  
N.Y.C., N.Y.

Devalbo—ASCAP

Dolfi—ASCAP  
1619 Broadway  
N.Y.C., N.Y.

Don—BMI  
2809 Erastus St.  
Houston, Texas

Don C—BMI  
515 Madison Ave.  
N.Y.C., N.Y.

Donna—ASCAP

Don Pow—BMI  
1619 Broadway  
N.Y.C., N.Y.

Doors—ASCAP  
c/o Abe Somer  
6380 Wilshire Blvd.  
Los Angeles, Calif.

Double Diamond—BMI  
250 S. Broad St.  
Philadelphia, Pa.

Dragoon Tunes/Kaskat—BMI  
200 W. 57 St.  
N.Y.C., N.Y.

Drive In—BMI  
c/o Original Sound  
7120 Sunset Blvd.  
Los Angeles, Calif.

Duane—BMI  
P.O. Box 174  
Albany, Calif.

Duchess—BMI  
445 Park Ave.  
N.Y.C., N.Y.

Duckstein/Kama Sutra  
c/o Buddah  
1650 Bway  
N.Y.C., N.Y.

Dunbar—BMI  
1650 Broadway  
N.Y.C., N.Y.

Dwarf—ASCAP  
640 5th Ave.  
N.Y.C., N.Y.

Dynatone—BMI  
1540 Brewster Ave.  
Cincinnati, Ohio

(Con't. on next page)

# MY HOUSE By Mildred Fields

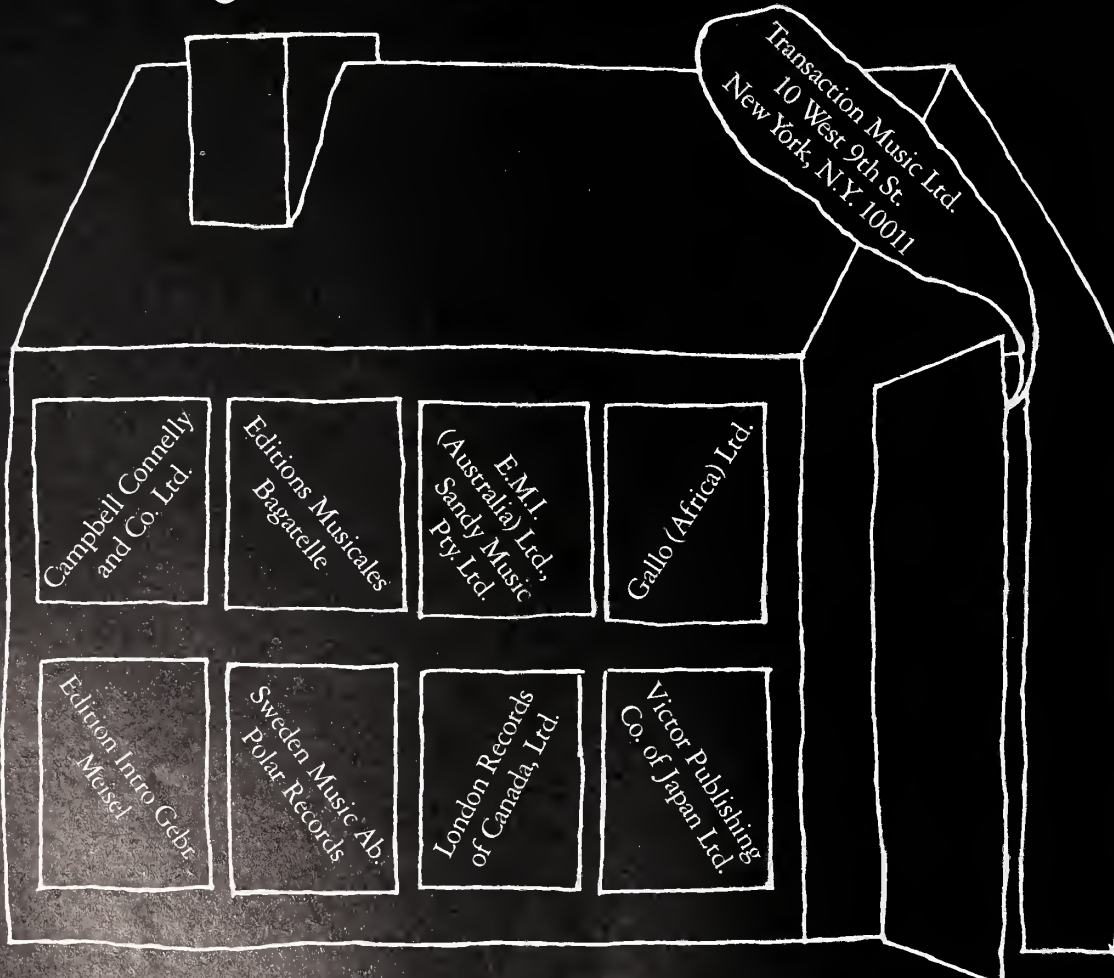

Welcome to my house. Here one short distance call can result in the greatest mileage in the world for your repertoire.

Living under this one American roof, are the great record and publishing companies of the world. Specifically:

EDITIONS MUSICALES BAGATELLE of France and Benelux.

CAMPBELL CONNELLY & CO. LTD. and CONCORD RECORDS of England.

E.M.I. (AUSTRALIA) LTD. of Australia.

GALLO (AFRICA) LTD. of South Africa.

EDITION INTRO GEBR. MEISEL of Germany.

LONDON RECORDS LTD. of Canada.

POLAR RECORDS and SWEDEN MUSIC, AB. of Scandinavia.

SANDY MUSIC PTY. LTD. and VIKING RECORDS of New Zealand.

VICTOR PUBLISHING CO. LTD. of Japan.



TRANSACTION MUSIC LTD. 10 WEST 9TH ST., N.Y., N.Y. 10011, U.S.A. PHONE: (212) 982-1951 CABLE: TRANSMUSIC

# Belwin Mills Publishing Corp.

*"UNDER ONE ROOF"*

*Music Covering Every Facet of the Educational, Recreational and Professional Fields*

## **POP MUSIC DIVISION**

### **BELWIN-MILLS ASCAP MULTIMOOD BMI**

ON THE CHARTS:

UNITED WE STAND — Brotherhood of Man (Deram)

THE WITCH — Rattles (Probe)

TWO LITTLE ROOMS — Janet Lawson (UA)

YOU'VE BEEN MY INSPIRATION — Main Ingredient (RCA)

### **DOUBLE M PRODUCTIONS**

CURRENTLY OUT:

JOHNNY'S MUSIC MACHINE — Rock Garden (Capitol)

SOON TO BE RELEASED:

THE AD LIBS; SOLOMON; JIMMY WOODS;

RICK LISI; CHRIS BARTLEY

## **SERIOUS MUSIC AND PRINTED PRODUCT DIVISION**

EXCLUSIVE DISTRIBUTOR FOR PRINTED PRODUCT:

### **JOBETE MUSIC CO.**

DIVISIONS:

#### **FRANCO COLOMBO PUBLICATIONS**

Publishers of the new opera "OF MICE AND MEN"

HENRY ADLER PUBLICATIONS

HALBE COMPOSER STATUETTES AND PLAQUES

J. FISCHER & BROS.

EXCLUSIVE DISTRIBUTORS TO THE MUSIC TRADE:

SINGSPARATION, INC.

MUSIC MINUS ONE, INC.

EXCLUSIVE AGENTS IN THE U.S.A.:

AMPHION, S.A.R.L.; F. BONGIOVANNI; BOSWORTH & CO., LTD.; J. W. CHESTER, LTD.;  
A. FORLIVESI & CO.; NOVELLO & CO., LTD.; OTOS, S.A.S.; G. RICORDI & CO.; SYMPHONIA  
VERLAG; B. SCHOTT'S SOEHNE; SCHOTT & CO., LTD.; EDITIONS SALABERT; MUSIK-  
VORLAGE HANS SIKORSKI; CASA MUSICALE SONZOGNO.

## **BELWIN-MILLS PUBLISHING CORP.**

POP & SERIOUS  
MUSIC DIV. 16 W. 61st Street,  
New York, N.Y. 10023  
Telephone: (212) 245-1100

PRINTED PROD. 250 Maple Avenue,  
DIV. Rockville Centre, N.Y. 11571  
Telephone: (516) 766-6700

BELWIN-MILLS MUSIC, LTD.  
20 Denmark Street,  
London, W.C.2., England

MILLS FRANCE, SARL,  
67 Rue de Provence,  
Paris 9e, France

MILLS MUSIC DE MEXICO,  
Tenayuca 187-102,  
Col. Vertiz Narvarte, Mexico

EDITORIA MILLS MUSIC LTDA.,  
Avenida Ipiranga 1123  
Sao Paulo, Brazil

BELWIN-MILLS MUSIKVERLAG GMBH  
Hohenzollerndamm 54A,  
1 Berlin 33, Germany.

MILLS HOLLAND,  
Leidesgracht 11,  
Amsterdam, Holland.

EDITORIAL MILLS MUSIC ESPANOLA,  
(Ediciones Quiroga)  
Alcala 70, Madrid 9, Spain.

# The Only Centralized Service Dealing With All Phases of Copyright

\* TELEVISION  
SHOWS  
Tape and Film

\* MOTION  
PICTURES

\* RECORDS

\* MUSIC  
PUBLISHER  
ADMINISTRATION

Handling of all paper work.  
Maintaining accurate files.

\* COMMERCIALS

\* MUSIC  
RESEARCH

ALL ADDITIONAL AREAS  
INVOLVING COPYRIGHT  
AVAILABLE

TWENTY FIVE YEARS  
OF EXPERIENCE AND  
KNOWLEDGE AND  
SERVING THE INDUSTRY

TWENTY FOUR HOUR  
TELEPHONE SERVICE  
(213) 462-6575

*Mary  
Williams*

MUSIC  
CLEARANCE  
COMPANY

6223 SELMA AVE.  
HOLLYWOOD, CAL.  
90028

*publishers  
of the  
TOP  
100  
HITS*

## E

East—BMI  
460 Park Ave.  
N.Y.C., N.Y.

East/Memphis—BMI  
1501 Broadway  
N.Y., N.Y.  
926 E. McLemore  
Memphis, Tenn.

Eden—BMI  
1697 Broadway  
N.Y., N.Y.

Elaine—ASCAP

Elsher—BMI  
c/o Jerry Ross  
1855 Bway  
N.Y.C., N.Y.

Emily—ASCAP  
160 W. 73 St.  
N.Y.C., N.Y.

Emm-Jay—BMI  
25 W. 56 St.  
N.Y.C., N.Y.

EPI—ASCAP  
6418 N. Babcock St.  
N. Hollywood, Calif.

Evil Eye—BMI

Exbrook—BMI  
9110 Sunset Blvd.  
Los Angeles, Calif.

## F

Faithful—BMI  
745 5th Ave.  
N.Y.C., N.Y.

Fame—BMI  
P.O. Box 2238  
Muscle Shoals, Alaska

Famous—ASCAP  
1619 Bway.  
N.Y., N.Y.

Fampco/Sounds of Lucille—BMI  
c/o Bluesway  
8255 Beverly Blvd.  
Los Angeles, Calif.

Fat Zach—BMI  
c/o Neil C. Reshen  
150 W. 55th St.  
N.Y.C., N.Y.

Felsted—BMI  
539 W. 25th St.  
N.Y., N.Y.

Fifth Star Music—BMI  
8350 Santa Monica Blvd.  
Los Angeles, Calif.

Fine Arts/Kama Sutra—BMI  
c/o Buddah  
1650 Broadway  
N.Y.C., N.Y.

Fleetwood Mac—BMI  
23 Alberle St.  
London W1 Eng.

Jim Ford—BMI  
9000 Sunset Blvd.  
Los Angeles, Calif.

Four Star—BMI  
9220 Sunset Blvd.  
Los Angeles, Calif.

Fullness—ASCAP

## G

Al Gallico  
101 W. 55th St.  
New York, N.Y.

Gambi—BMI  
106 W. Palisades Ave.  
Englewood, N.J.

Gamble Huff—BMI  
250 S. Broad St.  
Philadelphia, Pa.

Gear—ASCAP  
28875 Franklin Rd.  
Southfield, Michigan

Gideon—BMI  
c/o Allen Klein  
1700 Broadway  
New York City, N.Y.

Gladys—ASCAP  
1619 Broadway  
N.Y.C., N.Y.

Gold Forever—BMI  
c/o R. Dunbar  
2429 Cadillac Tower  
Detroit, Mich.

Gold Hill—BMI

Golo—BMI  
1540 Brewster Ave.  
Cincinnati, Ohio

Gone Fishin—BMI

Grand Teton—BMI  
P.O. Box 6128  
Nashville, Tenn.

Great Honesty—BMI  
916 Kearny St.  
San Francisco, Calif.

Great Montana—BMI  
6922 Hollywood Blvd.  
Hollywood, Calif.

Green Apple—BMI  
6430 Sunset Blvd.  
Los Angeles, Calif.

Green Isle—BMI  
3106 Belmont Blvd.  
Nashville, Tenn.

Grosvenor House—ASCAP  
P.O. Box 1563  
Hollywood, Calif.

Gypsy Box—ASCAP  
c/o Harry Fox  
110 E. 59th St.  
N.Y.C., N.Y.

## H

Handsome—BMI  
9000 Sunset Blvd  
Los Angeles, Calif

Harris—BMI  
c/o ABKCO  
1700 Broadway  
N.Y.C., N.Y.

Harrison—ASCAP  
6290 Sunset Blvd.  
Los Angeles, Calif.

Harthon—BMI  
5408 Calnor Rd.  
Philadelphia, Pa.

Hastings—BMI  
1350 Ave of the Am.  
N.Y.C., N.Y.

Heather—BMI  
157 W. 57th St.  
N.Y.C., N.Y.

Heavy—BMI  
c/o Cadet Concept  
320 E. 21st St.  
Chicago, Ill.

Hilliard—BMI  
1717 N. Highland Ave.  
Hollywood, Calif.

Hill & Range—BMI  
241 W. 72nd St.  
N.Y., N.Y.

Hi-Lo—BMI  
639 Madison Ave.  
Memphis, Tenn.

Hollenback—BMI  
c/o Lou Adler  
51 W. 52nd St.  
N.Y.C., N.Y.

Hollis—BMI  
10 Col Circle  
N.Y.C., N.Y.

House of Bryant—BMI  
530 W. Main St.  
Hendersonville, Tenn.

House of Cash—BMI  
2200 Gallatin Rd.  
Madison, Tenn.

## I

Icebag—BMI  
15 W. 44th St.  
N.Y.C., N.Y.

Ides—BMI  
304 Hanks  
Aurora, Ill.

Immediate—BMI  
1700 Broadway  
N.Y.C., N.Y.

Interval—BMI  
c/o Alan Corber  
15 W. 72nd St.  
N.Y.C., N.Y.

Intune Inc.—BMI  
London, England

I.P.G.—BMI  
1175 Howard St.  
San Francisco, California

Irving—BMI  
1416 N. La Brea  
Hollywood, Calif.

Ishmael—BMI  
8961 Sunset Blvd.  
Los Angeles, Calif.

(Con't. on next page)

# TRO

Throughout the world...  
the symbol of creative music  
publishing and exploitation for  
composers, authors and publishers

## TRO

The **RICHMOND ORGANIZATION**  
10 Columbus Circle, New York, New York 10019

Canada: **ESSEX MUSIC OF CANADA LTD.**

## TRO

The **ESSEX MUSIC GROUP**  
Dumbarton House, 68 Oxford St., London W1N 9LA, England  
**DAVID PLATZ**, Director of International Operations

**TRO** | **ESSEX MUSIC OF AUSTRALIA PTY. LTD.** King York House, 32-34 York St., Sydney, N.S.W. 2000, Australia. Barry Kimberley, Managing Director

**TRO** | **EDITIONS ESSEX S.A.** 28 Boulevard Poissonniere, Paris 9<sup>e</sup>, 34, Avenue des Champs-Elysees, Paris 8e, France. Ellen Nathan, Gerant

**TRO** | **ESSEX MUSIKVERTRIEB G.m.b.H.** Drususgasse 7-11, Cologne 1, Germany.

**TRO** | **EDIZIONI MARIO AROMANDO S.r.L.** Galleria Del Corso 4, Milan, Italy. Sandro Pieralli, Professional Manager

**TRO** | **LES EDITIONS ESSEX-HOLLAND** Leidsegracht 11, Amsterdam-C, Holland.

**TRO** | **MUSIKFORLAGET ESSEX A/B** Regeringsgatan 45, S-111 56, Stockholm, Sweden.

**TRO** | **EDICIONES ESSEX ESPANOLA S.A.** Diputacion, 337-1, 2, Barcelona 9, Spain.

**TRO** | **ESSEX JAPAN LTD.** 13, 2-chome, Tsukasa-cho Kanda, Chiyoda-ku, Tokyo, Japan.

**TRO** | **ESSEX DE MEXICO S.A.** Insurgentes Sur, 473 Penthouse, Mexico 11, D.F., Mexico. Charles Grever, Manager

**TRO** | **ESSEX MUSIC GROUP PTY. LTD.** P.O. Box 6857, Johannesburg, South Africa. Ken McManus, Managing Director

# 4 STAR MUSIC CO., INC.

9220 SUNSET BLVD., SUITE 312  
LOS ANGELES, CALIFORNIA 90069  
278-1780

## HAPPY ANNIVERSARY TO CASH BOX MAGAZINE 4-STAR MUSIC CO., INC. AND ITS WRITERS

KEITH COLLEY	BETTY JEAN ROBINSON
DICK MONDA	EDDIE MILLER
JEAN CHAPEL	CINDY WALKER
CARL BELEW	ALAN BRACKETT
MIKE FENNELLY	SANDY SALISBURY

*publishers  
of the  
TOP  
100  
HITS*

Itasca—BMI  
Union Bank Plaza  
15233 Ventura Blvd.  
Sherman Oaks, Calif.

### J

Jac—ASCAP  
c/o Fred E. Ahlert, Jr.  
15 W. 48th St.  
N.Y.C., N.Y.

Jama—(ASCAP)  
2552 W. 5th St.  
Los Angeles, California

Jalynne—BMI  
2203 Spruce St.  
Philadelphia, Pa.

January/Welbeck—BMI  
25 W. 56th St.  
N.Y.C., N.Y.

Jillbern—BMI  
c/o Pocketful of Tunes  
39 W. 55th St.  
N.Y.C., N.Y.

Joachim—BMI  
130 W. 57th St.  
N.Y.C., N.Y.

Jobete—BMI  
247 Woodward Ave.  
Detroit, Michigan

Jondora—BMI  
c/o Fantasy  
1281 30th St.  
Oakland, Calif.

Joni—BMI  
1421 S. Michigan  
Chicago, Ill.

### K

Kags—BMI  
6922 Hollywood Blvd.  
Hollywood, Calif.

Kama Rippa/Amelania—ASCAP  
1650 Broadway  
N.Y., N.Y.

Kama Rippa/Edwin Hawkins—ASCAP  
729 7th Ave.  
N.Y., N.Y.

Kangaroo—BMI  
225 E. 63rd St.  
N.Y.C., N.Y.

Kaskat—BMI  
c/o W. 57th St.  
N.Y.C., N.Y.

Don Kirshner—BMI  
655 Madison Ave.  
N.Y.C., N.Y.

Klondike—BMI  
c/o Stax  
926 E. McLemore St.  
Memphis, Tenn.

Knox—BMI

(Con't. on next page)

# Let's share the Top Ten together.

Artists. Writers. Record Companies. Coast to Coast and Around the World, you're aiming for the Top Ten. Wherever you are, you're close to a Sunbury/Dunbar office or representative. And we all talk the same language. Hits.

Sunbury Music, Inc. ASCAP/Dunbar Music, Inc. BMI  
1133 Avenue of the Americas  
NYC 10036, 212-586-5380

Offices also in Hollywood and Nashville.  
Representatives in: Argentina, Australia, Belgium,  
Brazil, Canada, France, Holland, Israel, Italy, Japan,  
Mexico, South Africa, Spain, Sweden, United Kingdom.

Gerald Teifer — President  
James Kronides — Prof. Mgr.  
Harold Fine — Mgr. Adm.  
Chuck Meyer — Hollywood  
Russ Allison — Nashville



# You can have us for a song.



SONGS FOR PEOPLE IN LOVE



SONGS FOR YOUNG PEOPLE

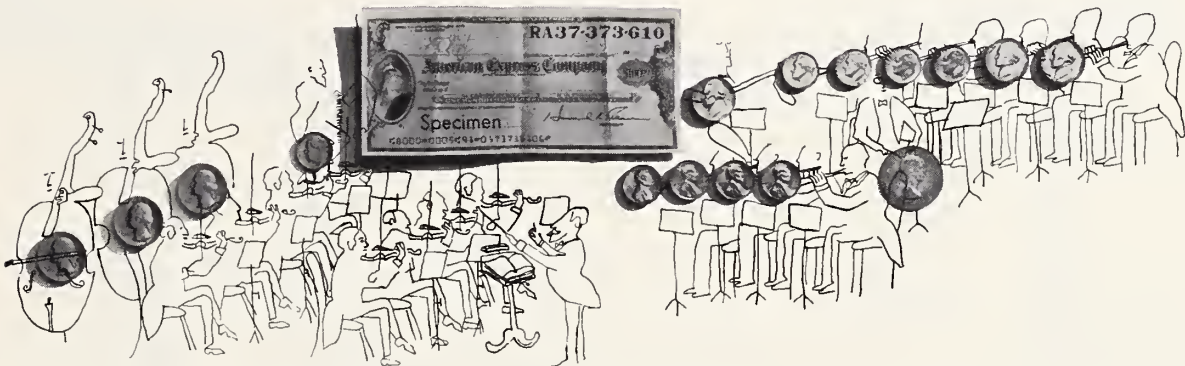

SONGS TO SELL WITH (COMMERCIALS AND JINGLES)



SONGS FOR THE MOVIES AND TV SHOWS



SONGS AROUND THE WORLD

**Screen Gems-Columbia Music, Inc.**  **Roosevelt Music Co. Inc.**   
Divisions of Columbia Pictures Industries, Inc.

Offices around the world.

## SOME GREAT COPYRIGHTS . . .

<b>All The Things You Are</b>	<b>Kiss Me Kate Score</b>
<b>Blue Christmas</b>	<b>(Management Only)</b>
<b>Blue Velvet</b>	<b>Look For The Silver Lining</b>
<b>Bluebird Of Happiness</b>	<b>Make Believe</b>
<b>Canadian Sunset</b>	<b>Ol' Man River</b>
<b>Can't Help Lovin' Dat Man</b>	<b>Orchids In The Moonlight</b>
<b>Carousel Score</b>	<b>Smoke Gets In Your Eyes</b>
<b>(Management Only)</b>	<b>Suddenly There's A Valley</b>
<b>Chanson D'Amour</b>	<b>To Know You Is To Love You</b>
<b>Goin' Out Of My Head</b>	<b>Watch What Happens</b>
<b>Hurt So Bad</b>	<b>Wayward Wind, The</b>
<b>I Want A Girl</b>	<b>When My Baby Smiles At Me</b>
<b>I Will Wait For You</b>	<b>Who</b>
<b>Isle Of Capri</b>	<b>Why Do I Love You</b>
<b>I've Told Ev'ry Little Star</b>	<b>Wonderful Time Up There, A</b>

. . . and many others

## T. B. HARMS COMPANY

Bibo Music Publishers, Inc.  
Harry Von Tilzer Music Pub. Co.  
Vogue Music, Inc.

### New York Office

Frank Abramson  
1619 Broadway  
New York, N. Y. 10019  
Lt-1-3197

### California Office

Paul Weirick  
2444 Wilshire Blvd.  
Santa Monica, Calif. 90403  
Up-0-7076



**FOUR  
STAR**

Alfred Perry — Exec. Vice Pres.

*Stellar Music Co.*  
*B.N.P. Music Publishing Co.*

6290 SUNSET BLVD., HOLLYWOOD CALIF 90028 • (213) 482-0725

Publishers of songs by:

R.B. GREAVES	DOUGLAS FIR
DEAN KAY	RICK McCLELLAN
HAL BLAIR	JERRY WRIGHT
ARTHUR HAMILTON	NICK ALEXANDER
KELLY GORDON	LALO SCHRIFRIN
PETER DANIELS	BOB SIMPSON
NORMA GREEN	CHUCK JONES
TAD SUCKLING	BUZZ SILER
GLORIA SKLEROV	MARTIN KOSINS

. . . and many others

FRED BENSON-Vice Pres.

ALLAN BREED

*publishers  
of the  
TOP  
100  
HITS*

## L

Landeville—ASCAP  
c/o Marge Johnson  
226 S. Bev. Dr.  
Los Angeles, Calif.

Las G-Round—BMI  
82 E. 59 St.  
Harvey, Ill.

Leeds—ASCAP  
445 Park Ave.  
N.Y.C., N.Y.

Legacy—BMI  
1855 Broadway  
N.Y.C., N.Y.

Lexilon—ASCAP  
10701 Camarillo  
N. Hollywood, Calif.

Little Heather/MRC—BMI  
c/o Mercury  
110 W. 57 St.  
N.Y., N.Y.

London—BMI  
200 W. 57 St.  
N.Y.C., N.Y.

Love Songs/Peanut Butter—BMI  
1650 Broadway  
N.Y., N.Y.

Lowery—BMI  
P. O. Box 9687  
Atlanta, Georgia

Low/Sal—BMI  
c/o Bill Lowery  
P. O. Box 9687  
Atlanta, Georgia

Low-Twi—BMI  
P. O. Box 9687  
Atlanta, Georgia

## Mc

McCoy-Chevis—BMI  
1619 Broadway  
N.Y.C., N.Y.

McLaughlin—BMI  
10 E. 44 St.  
N.Y.C., N.Y.

## M

Maclen—BMI  
1780 Broadway  
N.Y., N.Y.

Major Oak—ASCAP  
c/o Kant & Gordon  
9465 Wilshire Blvd.  
Beverly Hills, Calif.

Makalotto—BMI  
1777 N. Vine  
Los Angeles, Calif.

Malicious Melodies—ASCAP  
9031 Sunset Blvd.  
Los Angeles, Calif.

Man-Ken—BMI  
444 Madison Ave.  
New York, N.Y.

Maribus—BMI  
1780 Bway  
N.Y.C., N.Y.

Mariposa—BMI  
713 18th Ave.  
S. Nashville, Tenn.

E. B. Marks—BMI  
136 W. 52 St.  
N.Y.C., N.Y.

Marsaint—BMI  
c/o Toussaint-Sehorn

Mawil—BMI  
c/o Willie M. Hutchinson  
1943 W. Vernon Ave.  
Los Angeles, Calif.

Mee-Moo—BMI  
9220 Sunset Blvd.  
Los Angeles, Calif.

Mellin—BMI  
1650 Bway  
N.Y.C., N.Y.

Melrose—Ascap  
31 W 54th St.  
N.Y.C., N.Y.

Meoldy Trails—BMI  
10 Columbus Circle  
N.Y.C., N.Y.

Merlin—BMI  
1700 Broadway  
N.Y.C., N.Y.

Metric—BMI  
729 7th Ave.  
N.Y.C., N.Y.

Michele—BMI  
6724 Abbot Ave.  
Van Nuys, Calif.

(Con't. on next page)

## Gil Music Corp. (BMI)

## George Pincus & Sons Music Corp.

Songfest Music Inc.

Gil Ent. Inc.

George Pincus, President  
Irwin Pincus, Vice President  
1650 Broadway, New York, N.Y. 10019  
(212) 245-0110



**2 Decades ago Al Gallico Songs were heard for the first time in Nashville, Tenn.**

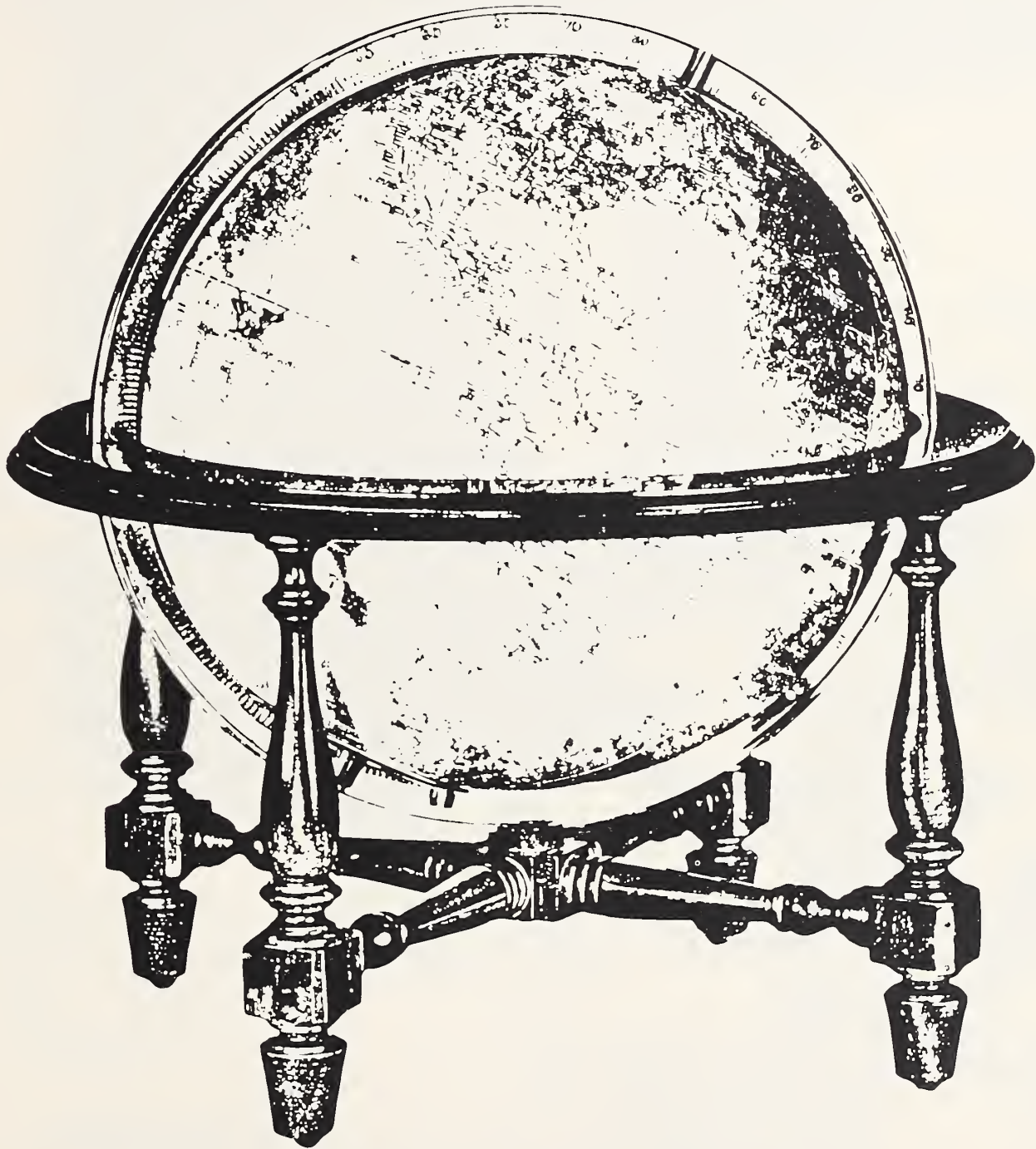

**Now they are heard around the world.**

**AL GALICO MUSIC CORPORATION**

101 West 55th Street, New York, N.Y./Nashville: 812 16th Ave. So.

Norris Wilson, Mgr.

**We Love  
SINGLES!**

**Records or  
One-word Titles . . . . .**

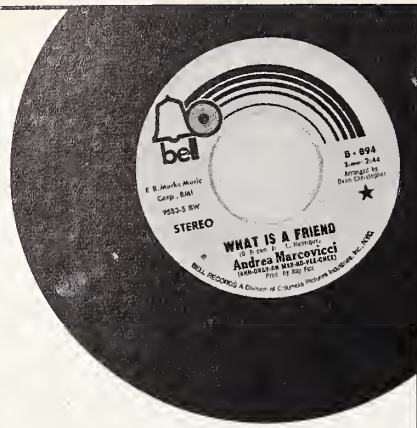

<b>MORE</b>	<b>MALAGUENA</b>
<b>GLOW-WORM</b>	<b>MANHATTAN</b>
<b>YOURS</b>	<b>AMAPOLA</b>
<b>CINDY</b>	<b>ANDALUCIA</b>
<b>SARI</b>	<b>POINCIANA</b>
<b>HARRIGAN</b>	<b>LOLLIPOP</b>
<b>MARTA</b>	<b>NIGHTINGALE</b>

**. . . in one word  
we love HITS!  
and now the  
Singular Off-Broadway Smash!**

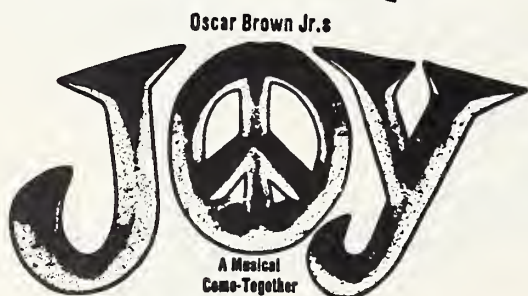

**OFFERS**  
**Such Potential International Hits as**

<b>BROWN BABY*</b>	<b>WHAT IS A FRIEND?*</b>
<b>IF I ONLY HAD*</b>	<b>A NEW GENERATION*</b>
<b>FUNNY FEELIN'</b>	<b>MUCH AS I LOVE YOU</b>
<b>FUNKY WORLD</b>	<b>FLOWING TO THE SEA</b>
<b>NOTHING BUT A FOOL</b>	<b>MOTHER AFRICA'S DAY</b>

*\*Available as singles too*

Original Cast Album on **RCA** LSO 1166

MURRAY BAKER, General Professional Manager  
**Edward B. Marks Music Corporation**

136 West 52nd Street, New York, N.Y. 10019  
Telephone: (212) CI 7-7277

*publishers  
of the  
TOP  
100  
HITS*

Milky Way—BMI  
25 Central Park W.  
N.Y.C., N.Y.

Mocart—BMI

Modo—BMI  
c/o Allovetti  
1650 Broadway  
N.Y.C., N.Y.

Moo-Lah—BMI  
c/o Ed Sullivan  
7135 Blackson  
Chicago, Ill.

Moon Beam—ASCAP  
101 W. 55 St.  
N.Y.C., N.Y.

Mozella—BMI  
c/o Sue  
265 W. 54 St.  
N.Y.C., N.Y.

Multimood—BMI  
16 W 61st St.  
N.Y.C., N.Y.

Mured—BMI  
8008 Rodgers Rd.  
Elkins Park, Pa.

Myto—BMI  
4039 Buena Vista St. W.  
Detroit, Mich.

M.Z.G. Music—ASCAP  
c/o Tec  
6331 Hollywood Blvd.  
Hollywood, Calif.

**N**

New Colony—BMI  
166 E. Superior St.  
Chicago, Ill.

New Film—BMI  
c/o Ernest Pintoff  
130 E. 75 St.  
New York, N.Y.

New Life—BMI  
1619 Broadway  
N.Y., N.Y.

Ninandy—BMI  
221 W. 57 St.  
N.Y., N.Y.

Nickel Sho—BMI  
c/o Stan & Bell  
250 S. Broad St.  
Philadelphia, Pa.

Nipper/Doors—ASCAP  
51 W. 51 St.  
N. Y. C., N.Y.

Niper—ASCAP  
1855 Broadway  
N.Y.C., N.Y.

No Exit—BMI  
535 Cotton Ave.  
Macon, Ga.

Noo Track—ASCAP

**O**

Odum—Neiburg

One Eye Soul/Van McCoy—BMI  
341 N. Woodland St.  
Englewood, N. J.

**P**

Painted Desert—BMI  
666 5th Ave.  
N.Y., N.Y.

Pamco—BMI  
c/o Bluesway  
1330 Ave of America  
N.Y.C., N.Y.

Pan Bar—BMI

Papa Joe's—ASCAP  
1007 17 Ave. S.  
Nashville, Tenn.

*Ivan Mogull  
Associates*

*Current Song Folios*

- ★ FELICIANO
- ★ TOMMY ROE
- ★ CHARLEY PRIDE
- ★ JOE SOUTH
- ★ JERRY REED
- ★ VOGUES
- ★ CLASSICS IV

*Watch for more of Our Outstanding Folios*

EXECUTIVE OFFICES

IVAN MOGULL ASSOCIATES

40 East 49th Street, New York, New York 10017  
212 355-5636

\* \* \* \* \*

SALES and SHIPPING  
WEST COAST PUBLICATIONS, INC.

4423 West Jefferson Boulevard, Los Angeles, California 90016



# With an ear to the Future

## Famous Music Publishing Companies

FAMOUS MUSIC — ASCAP  
PARAMOUNT MUSIC — ASCAP

NEW YORK

1 Gulf+Western Plaza  
New York, N.Y. 10023  
(212) 333-5800

L.A.

Suite 326  
6290 Sunset Blvd.  
Hollywood 90028  
(213) 461-3091

ENSIGN MUSIC — BMI  
EAST/MEMPHIS MUSIC — BMI

NASHVILLE

1605 Hawkins St.  
Nashville, Tenn. 37203  
(615) 244-6337

A DIVISION OF FAMOUS MUSIC CORPORATION  
A GULF + WESTERN COMPANY

*publishers  
of the  
TOP  
100  
HITS*

Parabut—BMI  
1501 Broadway  
N.Y.C., N.Y.

Patchaal—BMI

Peer Int'l—BMI  
1619 Broadway  
N.Y.C., N.Y.

Pequod—ASCAP  
8961 Sunset Blvd.  
Los Angeles, Calif.

Peyton—BMI  
3901 Ursula Ave.  
L. A., Calif.

Pigfoot—ASCAP  
4502 18th St.  
San Francisco, Calif.

Pisces—BMI  
6724 S. Stony Island Ave.  
Chicago, Illinois

Pocketful of Tunes  
c/o Wes Farrell  
39 W. 55th St.  
N.Y.C., N.Y.

Points West—BMI  
1523 Blair St.  
Houston, Texas

Pomona—BMI  
666 5th Ave.  
N.Y.C., N.Y.

Porpete—BMI  
1820 S. Van Ness  
Los Angeles, Calif.

Elvis Presley—BMI  
241 W. 72 St.  
N.Y.C., N.Y.

Press—BMI  
905 16th Ave. S.  
Nashville, Tenn.

Prodigal Son

Progressive—BMI  
241 W. 72 St.  
N.Y., N.Y.

Pronto—BMI  
1841 Broadway  
N.Y., N.Y.

Propett—BMI  
c/o Tom Catalano  
16715 Charmell Lane  
Pacific Palisades, Calif.

Pundit—BMI

**Q**

Quartet—ASCAP  
1619 Broadway  
N.Y.C., N.Y.

**R**

Anne Rachael—ASCAP  
1690 Broadway  
N.Y.C., N.Y.

Ramrac Ltd.—ASCAP  
London, England

Redwall—BMI  
535 Cotton Ave.  
Macon, Georgia

Regent—BMI  
1619 Broadway  
N.Y.C., N.Y.

Remick—ASCAP  
488 Madison Ave.  
N.Y.C., N.Y.

RhineLander—BMI  
130 W. 57 St.  
N.Y.C., N.Y.

RHOMARS—BMI

Rivers—BMI  
8923 Sunset Blvd.  
Los Angeles, Calif.

Johnny Rivers—BMI  
c/o Gang Tyre Brown  
6400 Sunset Blvd.  
Los Angeles, Calif.

Robbins—ASCAP  
1350 Ave of Americas  
N.Y.C., N.Y.

Rococco—BMI  
427 N. Canyon Dr.  
Beverly Hills, Calif.

Wally Roker—BMI  
1242 N. Highland  
Los Angeles, Calif.

Ruler—BMI  
P.O. Box 326  
Sheffield, Alaska

**S**

St. George—BMI

Samphil/Ronique—BMI

Sattwa—ASCAP  
6671 Sunset Blvd.  
Los Angeles, Calif.

Saturday—BMI  
c/o Bob Crewe  
1841 Broadway  
N.Y.C., N.Y.

Screen Gems/Columbia—BMI  
771 5th Ave.  
New York City, N.Y.

Sea Lark—BMI  
c/o Abbey Schroeder  
20 W. 56 St.  
N.Y.C., N.Y.

Adam Sean—BMI  
9000 Sunset Blvd.  
Los Angeles, Calif.

Sea of Tunes—BMI  
9042 La Alba  
Whittier, Calif.

Shamlee—ASCAP  
c/o Decca  
445 Park Ave.  
N.Y.C., N.Y.

(Con't. on next page)

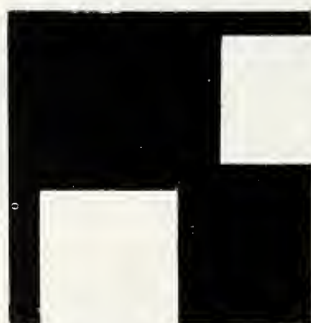

**AUDIO ARTS,**

AUDIO ARTS, INC. IS A COMPLETE COMPANY

**A PRODUCTION FIRM:**

"Lost Generation" Jimmy Webb  
on Bell 892

**A LABEL:**

"Fool Fool Fool"/ The Incredibles  
Audio Arts 10018

Including Gospel:

Cassietta George  
(Grammy Nominee 1969)  
Latest LP "Cassietta"  
Audio Gospel 1011

**PUBLISHING:**

Ja Ma Music (ASCAP) "Galveston"/"Didn't We"  
And other Jimmy Webb  
Songs You'll Soon Be Hearing

Madelon Music (BMI) ("Don't Wanna Make It Too Funky")  
In the Beginning"  
Featured on Roy Head's  
New Dunhill album  
An Extensive R&B Catalog

All a part of:

**AUDIO ARTS, INC.**

1552 Crossroads of the World  
Hollywood, Calif. 90028  
(213) 461-4029

MADOLON BAKER/PRESIDENT

GEORGE HOCUTT/EXEC. VICE PRES.

# BOG3

## A Global Music Publishing Network



### affiliates and representatives

**Robbins Music International (Argentina)**  
Buenos Aires, Argentina

**J. Albert & Son Pty. Ltd.**  
Sydney, Australia

**Weltmusik Edition International**  
Vienna, Austria

**Editions Francis-Day**  
Brussels, Belgium

**Robbins Music International (Brazil)**  
Rio de Janeiro, Brazil

**Gordon V. Thompson Limited**  
Toronto, Canada

**Robbins Music Corporation, Ltd.**  
London, England

**B. Feldman & Company, Ltd.**  
London, England

**Francis, Day & Hunter, Ltd.**  
London, England

**Editions France-Melodie**  
Paris, France

**Sidemton Verlag**  
Cologne, Germany

**Trident N.V.**  
Amsterdam, Holland

**Edizioni Curci**  
Milan, Italy

**Eastern Music Publishing Co., Ltd.**  
Tokyo, Japan

**Grever International S.A.**  
Mexico City, Mexico

**Robbins-Feist-Miller**  
New York—Hollywood

**Hastings Music Corporation**  
New York—Hollywood

**S. S. Suarez Music Company**  
Manila, Philippines

**Francis Day (S.A.) (Pty.) Ltd.**  
Johannesburg, South Africa

**Canciones del Mundo**  
Madrid, Spain

**Reuter & Reuter Forlags A.B.**  
Stockholm, Sweden

**Editions Sidem**  
Geneva, Switzerland

**Allen Stanton/Vice President & General Manager**  
**Werner Strupp/International Director**

*publishers  
of the  
TOP  
100  
HITS*

Larry Shayne—ASCAP  
6290 Sunset Blvd.  
Los Angeles, Calif.

Sherlyn—BMI  
495 S.E. 10th Ct.  
Hialeah, Fla.

Shelby Singleton Music—BMI  
3106 Belmont Blvd.  
Nashville, Tenn.

Siquomb—BMI  
55 Liberty St.  
N.Y.C., N.Y.

Sixuvus Revival/Kama Sutra—BMI  
1650 Broadway  
N.Y., N.Y.

Skinny Zat—ASCAP  
162 W. 56 St.  
N.Y.C., N.Y.

Skyhill—BMI  
P.O. Box 48638 Briggs Station  
Los Angeles, Calif.

Slacsar—ASCAP  
444 Madison Ave.  
N.Y.C., N.Y.

Sounds of Lucille/Pamco—BMI  
1330 Ave of Americas  
N.Y.C., N.Y.

Southdale—ASCAP

Southern Love—BMI  
c/o MRC  
110 W. 57 St.  
N.Y.C., N.Y.

Spanka—BMI  
200 W. 57 St.  
N.Y.C., N.Y.

Spiral—BMI  
241 Sands Ave.  
Las Vegas, Nev.

Stein & Van Stock—ASCAP  
c/o Tamla  
2457 Woodward Ave.  
Detroit, Mich.

SPR—BMI  
1697 Broadway  
N.Y., N.Y.

Stephanye—BMI  
10 E. 44 St.  
N.Y.C., N.Y.

Stone-Bridge—BMI  
c/o T. Catalano  
827 Thomas  
Memphis, Tenn.

Stone-Flower—BMI  
700 Urbano  
San Francisco, Calif.

Story Book—BMI  
720 5th Ave.  
N.Y.C., N.Y.

Stratt Songs Ltd—BMI  
1501 Broadway  
N.Y.C.

Strong Arm—ASCAP

Sunburby—ASCAP  
c/o RCA  
1133 Ave of Americas  
N.Y.C., N.Y.

Superhype—ASCAP  
444 Madison Ave.  
N.Y.C., N.Y.

Sweet Magnolia—BMI  
263 W. 55th St.  
N.Y., N.Y.

Symphony House—ASCAP  
Taventzien Strasse  
Berlin, W. Germany

## T

Tallyrand—BMI  
729 7th Ave.  
N.Y.C., N.Y.

Tamerlane—BMI  
6290 Sunset Blvd.  
Los Angeles, Calif.

Tangerine/Jalew—BMI  
2107 W. Washington-Blvd.  
Los Angeles, Calif.

Teeger—ASCAP  
163-07 Depot Rd.  
Flushing, N.Y.

Ten East—BMI  
7715 Sunset Blvd.  
Los Angeles, Calif.

Tepeamar—ASCAP  
c/o Amos  
6565 Sunset Blvd.  
L.A., Calif.

Third Story—BMI  
5455 Wilshire Blvd.  
Los Angeles, Calif.

Three Bridges—ASCAP  
110 W. 57 St.  
N.Y.C., N.Y.

Throat—BMI

Time—BMI  
449 S. Beverly Dr.  
Beverly Hills, Calif.

T.M.—BMI  
1619 Broadway  
N.Y.C., N.Y.

Tracebob/Unart—BMI  
c/o Minit  
6290 Sunset Blvd.  
Los Angeles, Calif.

Tracebob—BMI  
1337 Via Del Rey  
S. Pasadena, Calif.

Track—BMI  
260 W. 23 St.  
N.Y.C., N.Y.  
200 W. 57th St.  
N.Y., N.Y.

Tree—BMI  
905 16th Ave. S.  
Nashville, Tenn.

Treusdale—BMI  
449 S. Beverly Dr.  
Beverly Hills, Calif.

# IRVING AND ALMO ARE?

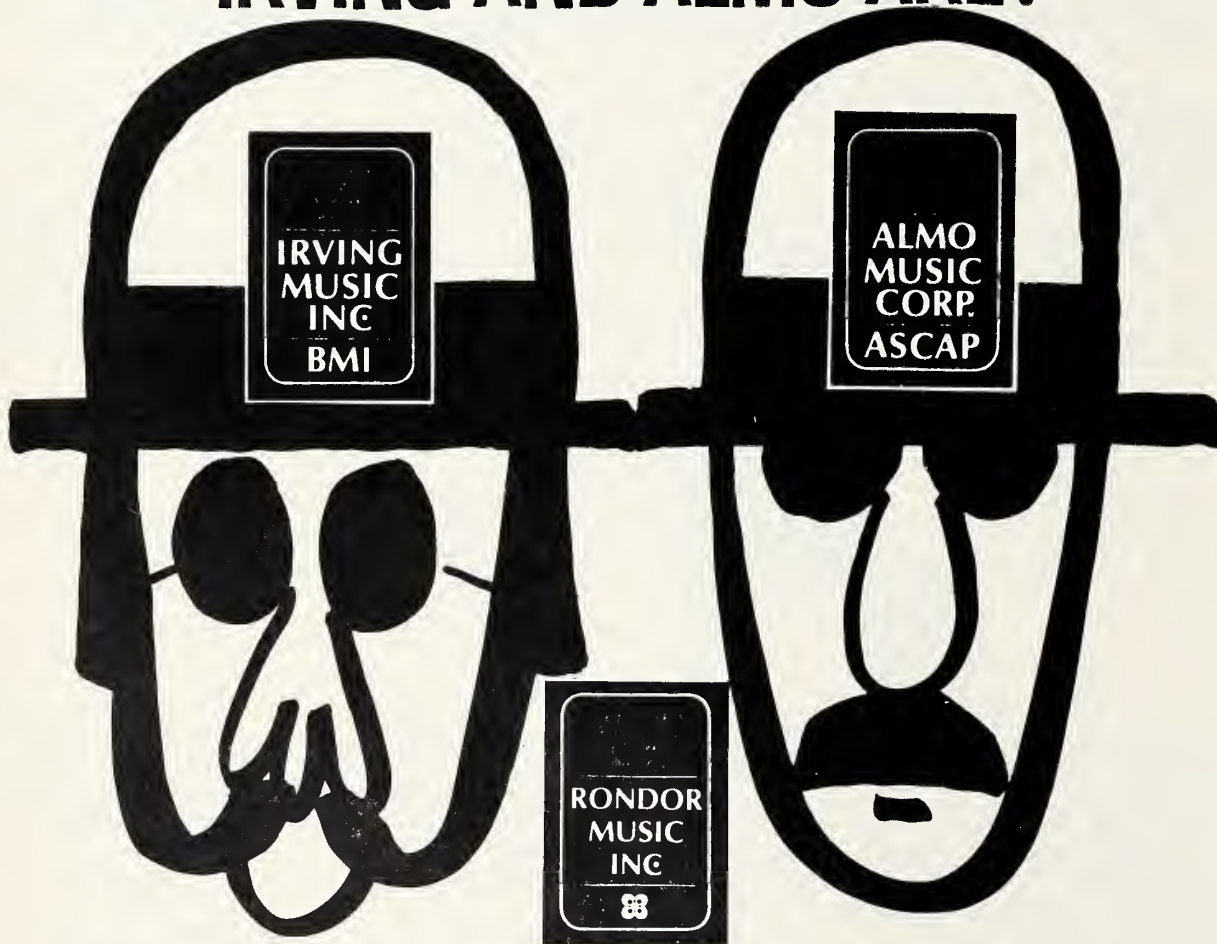

## The Rondor Group

ALMO MUSIC CORP. (ASCAP) / BERNA MUSIC (ASCAP) / BRIAN WILSON (ASCAP) / CHRYSALIS MUSIC (ASCAP) / GOOD SAM MUSIC (BMI) / IRVING MUSIC, INC. (BMI) / ISLAND MUSIC (BMI) / LA BREA MUSIC (ASCAP) / RODRA MUSIC, INC. (ASCAP) / SKYHILL PUB. CO. (BMI)

## Rondor Affiliates

ARGENTINA / Musicales Relay, S.A. • AUSTRALIA / Rondor Music Australia Pty. Ltd. • BRAZIL / Companhia Brasileira De Discos • ENGLAND / Rondor Music, (London) Ltd. • FRANCE / Agence Musicale Internationale • GERMANY • AUSTRIA • SWITZERLAND / Rondor Music (Germany) G.M.B.H. • HOLLAND • BELGIUM • Rondor, N.V. • ITALY / Gruppo Ricordi • MEXICO • CENTRAL AMERICA • VENEZUELA • COLOMBIA / Rondor Music S.A. • SCANDINAVIA / Sweden Music Ab. • SPAIN / Canciones Del Mundo • SOUTH AFRICA / Laetrec Music Limited.

## Major Copyrights

ALONG COMES MARY / BLACK PEARL / BRASILIA /  
BROTHER'S THEME / CAROLINE NO / CINDERELLA-  
ROCKEFELLA / CLASSICAL GAS / CYCLES / FEELIN'  
ALRIGHT / GOD ONLY KNOWS / GOOD VIBRATIONS /  
GREEN PEPPERS / GREENBACK DOLLAR / THE LONELY  
BULL / LET'S GET TOGETHER / THE MEXICAN  
SHUFFLE / PEACE OF MIND / A QUIET TEAR /  
SO WHAT'S NEW / SPANISH FLEA / SUNSHINE GIRL /  
TIAJUANA TAXI / WANDERLOVE / WINDS OF BAR-  
CELONA / WINDY / THE WORLD I USED TO KNOW

1416 N. LaBrea, Hollywood, Calif. 90028 (213) 464-7581





The  
Lowery  
Group  
of Music Publishing  
Companies

# THIS IS OUR BAG

Wherever you're from...Wherever you're going...You'll hear our music

Great songs like: "TRACES", "DIZZY", "STORMY", "THESE ARE NOT MY PEOPLE",

"EVERYDAY WITH YOU GIRL", "DON'T IT MAKE YOU WANTA GO HOME", "CHILDREN"

"BE YOUNG, BE FOOLISH, BE HAPPY", "WALK A MILE IN MY SHOES", "GAMES PEOPLE PLAY"

Written by these outstanding writers: JOE SOUTH, JAMES B. COBB, JR.,

BUDDY BUIE, RAY WHITLEY, FREDDY WELLER, TOMMY ROE

Lowery Music Co., Inc.  
Low-Twi Music Co., Inc.  
Low-Sal, Inc.



P.O. Box 9687  
Atlanta, Georgia 30319  
(404) 233-6703



# THE PEER-SOUTHERN ORGANIZATION

## PEER INTERNATIONAL CORPORATION SOUTHERN MUSIC PUB. CO. INC.

AND THEIR  
AFFILIATES  
TOGETHER  
WITH THEIR  
INTERNATIONAL  
PUBLISHING  
COMPANIES  
IN EVERY MAJOR  
MUSIC CENTER  
SERVE  
THE WORLD  
WITH MUSIC

MRS. MONIQUE I. PEER  
PRESIDENT

RALPH PEER II

VICE PRESIDENT

PROFESSIONAL DIVISION

LUCKY CARLE — ROY HORTON

JIMMY IENNER



*publishers  
of the  
TOP  
100  
HITS*

Tro Andover—ASCAP  
10 Columbus Circle  
N.Y.C., N.Y.

## BOURNE CO.

Music Publishers  
136 West 52nd Street  
New York, New York 10019  
(212) CI 7-5500

### Affiliated Companies

ABC MUSIC CO.  
BACH MUSIC  
BOURNE-FILMUSIC INC.  
BOGAT MUSIC  
HARBORN MUSIC, INC.  
LADY MAC MUSIC  
MURBO MUSIC  
PUBLISHING, INC.  
GOLDMINE MUSIC, INC.  
SCHUMANN MUSIC CO.

### MURBO RECORDS

### Hollywood Office

6362 Hollywood Blvd.  
Hollywood, California 90028

### ENGLAND

Bourne Music Limited  
34/36 Maddox Street  
London W.1, England

### FRANCE

Bourne-France  
10, Rue Washington  
Paris, 8, France

"MUSIC BORN TO LIVE"

Trio—BMI  
1619 Broadway  
N.Y.C., N.Y.

Triple 3—BMI  
1617 C. St.  
Sparks, Nevada

Tro Suffolk—BMI  
10 Columbus Circle  
N.Y.C., N.Y.

Tuna Fish—BMI  
555 Madison Ave.  
N.Y.C., N.Y.

Tune-Kel—BMI  
4318 MacArthur Blvd.  
New Orleans, La.

Tupco—BMI

20th Century—ASCAP  
444 W. 56 St.  
N.Y.C., N.Y.

## U

Unart—BMI  
729 7th Ave.  
N.Y.C., N.Y.

United Artists—ASCAP  
729 7th Ave.  
N.Y.C., N.Y.

Upfall—ASCAP  
161 W. 54 St.  
N.Y.C., N.Y.

Uzza—BMI  
c/o Al Scrumuzza  
1826 N. Broad  
New Orleans, La.

## V

Van Sand—ASCAP  
488 Madison Ave.  
N.Y.C., N.Y.

Vanlee—ASCAP  
101 W. 55 St.  
N.Y.C., N.Y.

Venice—BMI  
110 E. 59 St.  
N.Y., N.Y.

VIVA—BMI  
6922 Hollywood Blvd.  
Hollywood, Calif.

Vogue—BMI  
244 Wilshire Blvd.  
Santa Monica, Calif.

VSAV—ASCAP  
6922 Hollywood Blvd.  
Los Angeles, Calif.

## W

Walden—ASCAP  
1841 Broadway  
N.Y.C., N.Y.

Walrus—BMI

Warner Bros/7 Arts—ASCAP  
4000 Warner Blvd.  
Burbank, Calif.

Wendy—ASCAP  
1650 B'way  
New York, N.Y.

Welwom—BMI

Westward—BMI  
c/o Original Sound  
7120 Sunset Blvd.  
Los Angeles, Calif.

Wild—ASCAP  
807½ N.  
La Solla, Calif.

Wilderness—BMI  
913 17th Ave. S.  
Nashville, Tenn.

Willber—ASCAP  
c/o Barnaby Records  
889 Beverly Blvd.  
Los Angeles, Calif.

Jerry Williams—BMI  
8730 N. W. 16th Ave.  
Miami, Florida

Williamson—ASCAP  
609 5th Ave.  
N.Y., N.Y.

Wilric—BMI  
Sunset Dist.  
7447 N. Linden Ave.  
Skokie, Ill.

Wingate—ASCAP  
1330 Ave of Americas  
N.Y.C., N.Y.

Witmark—ASCAP  
c/o Warner Bros.  
4000 Warner Blvd.  
Burbank, Calif.

Wright Gerstele—BMI  
488 Madison Ave.  
N.Y., N.Y.

## Y

Yugoth—BMI  
c/o Dunwich  
25 Chestnut St.  
Chicago, Ill.

## Z

Zerlad—BMI  
136 E. 55 St.  
N.Y.C., N.Y.



Need Distributor  
Information?  
See Pages 80 - 106  
For Complete Listings

# Talked to the Trees lately?

With TREE INTERNATIONAL'S 15 foreign offices; a New York branch; a Hollywood branch . . . and TREE'S Nashville headquarters . . . there's bound to be a TREE near you! What's more, every TREE office is operated by people who are willing to go "out on a limb" to do their best for everyone.

Get world-wide results. Talk to a TREE.

*Tree  
International*



905 Sixteenth Avenue, South, Nashville, Tennessee  
Jack Stapp, President

Mailing Address: P.O. Box 1273 zip code 37202  
Buddy Killen, Vice President

Tree Music, Wilderness Music, Press Music, Green Grass Music, Twig Music, Ally Music, Cross Keys Music, Dial Records. U.S. Offices: Nashville, New York City, Hollywood Foreign offices: London Tree, Frankfurt Tree, Paris Tree, Milan Tree, Stockholm Tree, Madrid Tree, Amsterdam Tree, Prague Tree, Tokyo Tree, Sydney Tree, Johannesburg Tree. Latin American Tree offices in Buenos Aires, Rio de Janeiro, San Jose, and Mexico City

Sesac  
Publishers

A

**ABERNATHY PUBLISHING COMPANY**, Briarcliff Hotel, 1050 Ponce de Leon Avenue, N.E., Atlanta, Georgia, 30383

**ACCENT INC.**, (See Singspiration, Inc.)

**ACCORD, EDITION**, (See "IPA")

**ACCORDION MUSIC PUBLISHING COMPANY**, (See Deiro, Pietro, Publications)

**AKARD MUSIC INC.**, Box 17667, Dallas, Texas 75217

**ALBRIGHT MUSIC COMPANY**, (See National Music Company, Inc.)

**AMSCO MUSIC PUBLISHING COMPANY**, Div. of Music Sales Corporation, 33 West 60th Street, New York, N. Y. 10023, including: **AMSCO MUSIC SALES COMPANY**, ROAT, CHARLES E., MUSIC COMPANY

**AMSCO MUSIC SALES CO.**, (See Amsco Music Publishing Co.)

**ANDERSEN PUBLISHERS**, Route 1, Box 41, Warrensburg, Illinois 62573

**ANDREA MUSIC COMPANY, INC.**, 925 N. 3rd St., Philadelphia, Pa. 19123

**ARCT, M.**, (See "PWP")

**ARCT, WYDAWNICTWO MUZYCZNE**, (See "PWP")

**ARIMA MUSIC**, Suite 316, 6922 Hollywood Blvd., Hollywood, Calif. 90028

**AUGSBURG PUBLISHING HOUSE**, 426 South Fifth St., Minneapolis, Minn. 55415, including: **LUTHERAN PUBLISHING HOUSE**, **MESSENGER PRESS**, **THE WARTBURG PRESS**, **THE**

**AVALON MUSIC PUBLISHING COMPANY**, (See Stirling Music Publishing Company)

**AZTEC MUSIC COMPANY**, 61 Church St., Malverne, L. I., N. Y. 11565

B

**BABWIN PUBLICATIONS**, (See Pallma Music Company)

**BALTIMORE MUSIC COMPANY**, See Schmidt, A. P., Co.)

**BARNHOUSE, C. L., COMPANY**, 110 B Ave. East, Oskaloosa, Iowa 52577

**BARTLETT, E. M.**, (See Brumley, Albert E., & Sons)

**BAVA'S, JOHN, MUSIC**, Davis, West Virginia 26260, including: **MUSIC MELODY PUBLISHERS**

**BEIRLY, ALFRED, COMPANY**, (See Schmidt, A. P., Co.)

**BENDIX PUBLISHING CORP.**, (See National Music Company, Inc.)

**BENTOV, JEHUDA**, (See "IPA")

**BERQUIST, MAURICE**, P. O. Box 4187, South Daytona, Florida 32021

**BETTER CHOIRS**, (See Singspiration, Inc.)

**BETTER CHOIRS PUBLICATIONS, INC.**, (See Singspiration, Inc.)

**BIENSTOCK, SIEGFRIED**, (See "IPA")

**BILRUTH PRODUCTION CORP.**, 11 Riverside Drive, New York, N. Y. 10023

**BLACKWOOD, CECIL**, 209 North Lauderdale, Memphis, Tenn. 38105

**BLACKWOOD, JAMES**, 209 North Lauderdale, Memphis, Tenn. 38105

**BLACKWOOD BROTHERS QUARTET INC.**, 209 North Lauderdale, Memphis, Tenn. 38105

**BLUE MIST MUSIC**, (Div. of Shades of Blue Enterprises Inc.), 1906 South Street, Nashville, Tennessee 37203

**BRAUN, HUBERT J.**, (See Braun Music, Inc.)

**BRAUN MUSIC COMPANY**, (See Braun Music, Inc.)

**BRAUN MUSIC, INC.**, 33 West 60th St., New York, N. Y. 10023, including: **BRAUN, HUBERT J.**, **BRAUN MUSIC COMPANY**, **BRAUN ORGANIZATION**, **THE**

**BRAUN ORGANIZATION, THE**, (See Braun Music, Inc.)

**BRENNER MUSIC COMPANY**, Box 7001, Tampa, Fla., 33603

**BRIAR HILL MUSIC CORP.**, 359 North Canon Drive, Beverly Hills, Calif. 90210

**BRITE COUNTRY, INC.**, 728 16th Ave., So., Nashville, Tenn. 37203

**BROADCAST MUSIC PUBLISHERS**, (See National Music Company, Inc.)

**BROADMAN PRESS**, 127 Ninth Ave., N., Nashville, Tenn. 37203, including: **COLEMAN, ROBERT H.**, **COLEMAN, ROBERT H., PUB. CO.**, **CONVENTION PRESS**, **SUNDAY SCHOOL BOARD OF THE SOUTHERN BAPTIST CONVENTION**, **THE**

**BRONZE MUSIC, INC.**, 801 16th Ave., South Nashville, Tenn. 37203

**BROWNSBORO MUSIC**, (A Division of Sambo Inc.) 9912 Taylorsville Road, Louisville, Kentucky 40299

**BRUMLEY, ALBERT E. & SONS**, Powell, Missouri, 65730, including: **BARTLETT, E. M.**, **MOORE, DAVID**

C

**CANTWELL, RAY L.**, P. O. Box 4187, South Daytona, Florida 32021

**CAPITOL MUSIC COMPANY**, (See National Music Company, Inc.)

**CARDILLI, M. V.**, (See King Music Publishing Corp.)

**CARLTON MUSIC PUB.**, (See Ludwig Music Publishing Company)

**CARTER, ROY D., MUSIC COMPANY**, 4115 Vance Road, Ft. Worth, Texas 76118

**CASTION MUSIC**, 555 Kappock St., Apt. 21D, Riverdale, N. Y. 10463

**CATHOLIC MUSIC COMPANY**, (See McLaughlin & Reilly Company)

**CENTRAL MUSIC COMPANY**, 20209 Labrador St., Chatsworth, Calif. 91311, including: **RAMSEY, WILL M.**

**CENTRAL MUSIC PUB. CO.**, (See King Music Pub. Corp.)

**CENTURY MUSIC PUBLISHING COMPANY, INC.**, 39 West 60th St., New York, N. Y. 10023, including: **HERITAGE MUSIC PUBLICATIONS, INC.**, **KEYBOARD PUBLISHING COMPANY**

**CENTURY PRESS, INC.**, 412 N. Hudson, Oklahoma City, Okla. 73102

**CERRUTI, JOHN M.**, (See King Music Publishing Corp.)

**CHANTRY MUSIC PRESS, INC.**, at Wittenberg University, Box 1101, Springfield, Ohio 45501, including: **CHANTRY MUSIC PRESS, LTD.**

**CHANTRY MUSIC PRESS, LTD.**, (See Chantry Music Press, Inc.)

**CHART MUSIC PUBLISHING HOUSE, INC.**, (See Schmidt, A. P., Co.)

**CHERRY TREE PUBLICATIONS**, 614 Claridge Ave., Donelson, Tenn. 37214

**CHORAL PRESS, INC.**, 251 West 19th St., New York, N. Y. 10011

**CHORAL SERVICES, INC.**, (See Singspiration, Inc.)

**CHURCH MUSIC SERVICE BUREAU**, (See Singspiration, Inc.)

**CHURCH OF GOD PUBLISHING HOUSE, THE**, P. O. Box 830, Cleveland, Tenn. 37311, including: **VAUGHAN, JAMES D.**, **MUSIC PUBLISHER**

**CLAYTON, NORMAN J.**, (See Clayton, Norman Publishing Co.)

**CLAYTON, NORMAN, PUBLISHING CO.**, Winona Lake, Indiana 46590, including: **CLAYTON, NORMAN J.**

**CLEF MUSIC CORP.**, (See King Music Publishing Corp.)

**COLEMAN, ROBERT H.**, (See Broadman Press)

**COLEMAN, ROBERT H., PUBLISHING CO.**, (See Broadman Press)

**COLIN, CHARLES**, 315 West 53rd St., New York, N. Y., 10019

**CONCORD MUSIC PUBLISHING CO., INC.**, P. O. Box 1391, Studio City, Calif. 91604, (Only compositions as per list issued)

**CONCORDIA PUBLISHING HOUSE**, 3558 South Jefferson Ave., St. Louis, Mo. 63118

**CONCOURSE MUSIC CORP.**, 359 North Canon Drive, Beverly Hills, Calif. 90210

**CONTENTION MUSIC**, P. O. Box 824, Nashville, Tenn., 37202

**CONVENTION MUSIC CO. INC.**, 213 South Court St., Montgomery, Ala. 36104

**CONVENTION PRESS**, (See Broadman Press)

**COOPER, W. OLIVER**, (See Cooper, Wendell B., and Mrs. Camella)

**COOPER, WENDELL B. and MRS. CAMELLA**, Rt. 6, Cullman, Ala., 35055, including: **COOPER, W. OLIVER**

(Con't on next Page)

The  
sesac  
world of music

HOTELS  
STADIUMS  
SPECIAL EFFECTS  
BACKGROUND MUSIC  
RADIO RECORDINGS  
TELEVISION  
NIGHT CLUBS  
RESTAURANTS  
BALLROOMS  
DRUMMERS

One of the world's foremost music licensing organizations.



WORLD HEADQUARTERS: 10 Columbus Circle, New York, N.Y. 10019 • (212) 586-3450  
REGIONAL OFFICES: The SESAC Building, 1513 Hawkins Street, Nashville, Tenn. 37203 • (615) 244-1992



Sesac  
Publishers

C

**COPLEY MUSIC PUBLISHING CORP.**, c/o Pryor, Braun, Cashman & Sherman, 437 Madison Ave., New York, N. Y. 10022

**CORRIDOR MUSIC**, 3100 Belmont Blvd., Nashville, Tennessee 37212

**COUNTRY GENTLEMAN MUSIC**, Powell, Missouri, 65730

**CUMMINGS, M. HOMER**, 130 Cedar St., Huntington, W. Va. 25705

**CZYTELNIK**, (See "PWP")

D

**DAISY TOWN PUBLICATIONS**, Walker Hill Road, Rd. 2, Waverly, New York 14892

**DANIEL, JOHN**, (See Stoker Music Company, Inc.)

**DAROM, EDITION**, (See "IPA")

**DASH, JAMES ALLAN**, (See Schmidt, A. P. Co.)

**DAVIS, MARION, COMPANY, THE**, Fayette, Ala. 35555

**DAWSON, WILLIAM L.**, (See Music Press)

**DEAN, EMMET S.**  
**DEAN & EOMIASTON**  
**DEAN & EVRIDGE**  
**DEAN & FRANKLIN**  
**DEAN & HENSLEY**  
**DEAN & MORGAN**  
**DEAN & SEBREN**

(See Firm Foundation Publishing House)

**DEIRO, PIETRO**, (See Deiro, Pietro, Publications)

**DEIRO, PIETRO, PUBLICATIONS**, 133 Seventh Ave., So., New York, N. Y. 10014, including: ACCORDION MUSIC PUBLISHING COMPANY, DEIRO, PIETRO, FRADOR MUSIC MARKET, MOSTI, JOE, ACCORDION MUSIC HOUSE, VICCAS MUSIC PUBLISHING COMPANY

**DELHI PUBLICATIONS, INC.**, 440 Main St., Cincinnati, Ohio 45201

**DENSON-PARRIS MUSIC COMPANY**, (See Tennessee Music & Printing Co.)

**DENSON TRIO MUSIC COMPANY**, (See Tennessee Music & Printing Co.)

**DI BELLA, O., MUSIC COMPANY**, 456 South Washington Avenue, Bergenfield, New Jersey 07621

**DIAMANT, ABRAHAM**, (See "IPA")

**DICKER MUSIC COMPANY**, 62-33 Alderton St., Rego Park, L. I., N. Y. 11374

E

**EASTERLING, MARION W.**, Box 51, Clanton, Alabama, 35045

**EDEL, YIZCHAK**, (See "IPA")

**ELLIS MUSIC**, 12835 Indian Rocks Rd., Largo, Fla., 33540, including: ELLIS, V. B. (VEP)

**ELLIS, V. B. (VEP)**, (See Ellis Music)

**ELLIS, "VEP", SONGS**, Briarcliff Hotel, 1050 Ponce de Leon Avenue, N. E., Atlanta, Georgia 30383

**ENDICOES, ENTERPE LTOA.**, Av. Rio Branco, 108-2/204/206, Rio de Janeiro, Brazil

**EULENBERG, EDITION, GMBH.**, Adiswil-Zurich, Grutstrasse 68, Switzerland

**EULENBERG, ERNST, LTD.**, 48 Gt. Marlborough St., London, W1V, 2BN, England

F

**FABIAN, WERNER**, (See "IPA")

**FAIRBANK, H. W., COMPANY**, (See National Music Company, Inc.)

**FAITH MUSIC INC.**, Briarcliff Hotel, 1050 Ponce de Leon Avenue, N. E., Atlanta, Georgia 30383

**FIRM FOUNDATION PUBLISHING HOUSE**, P. O. Box 610, Austin, Texas 78767

**FITZ SIMONS, H. T., CO. INC.**, 615 N. LaSalle St., Chicago, Ill. 60610

**FLAMINGO MUSIC LTD.**, 14 Berkeley St., London, W. 1, England

**FORECAST MUSIC**, (See National Music Company, Inc.)

**FORESTSTORN MUSIC**, 321 East 45th St., PH-A NYC 10017

**FOUTS, S. G.**, 428 12th St., Cookeville, Tenn. 38501 including: FOUTS-PAYNE MUSIC COMPANY

**FOUTS-PAYNE MUSIC COMPANY**, (See Fouts, S. G.)

**FRADOR MUSIC MARKET**, (See Deiro, Pietro, Publications)

**FUTURE MUSIC**, (See National Music Company, Inc.)

G

**GAITHER, WILLIAM J.**, P. O. Box 300, Alexandria, Indiana 46001

**GALE MUSIC**, (See Sage and Sand Music Publishers)

**GEBETHNER & WOLFF**, (See "PWP")

**GENERAL COUNCIL OF THE ASSEMBLIES OF GOD** (See Gospel Publishing House)

**GEORGI & VITAK MUSIC COMPANY**, (See Vitak-Elsnic Company)

**GIL-RON, EDITION**, (See "IPA")

**GINZBURG, DOV, PUBLICATIONS**, (See "IPA")

**GLACO PUBLICATIONS, INC.**, 916 19th Avenue, South Nashville, Tennessee 37212

**GOOD SHEPHERD MUSIC CO.**, P. O. Box 2598, Asheville, N. C. 28802

**GOSPEL MUSIC PUBLICATIONS**, (See Hathaway, Franklin Earl, Mus. Pub.)

**GOSPEL PUBLISHING HOUSE**, 1445 Boonville Ave., Springfield, Missouri 65802, including: GENERAL COUNCIL OF THE ASSEMBLIES OF GOD

**GOSPEL QUARTET MUSIC, INC.**, P. O. Box 6992, Nashville, Tenn. 32715

**GRABCZEWSKI, F.**, (See "PWP")

**GREGORIAN INSTITUTE OF AMERICA, INC.**, 2115 W. 63rd Street, Chicago, Illinois 60636

**GUR-ARI, HANS (HOROWITZ)**, (See "IPA")

**GURLEY, ROBERT G.**, (See Jusko, Ralph, Publications, Inc.)

**GURLEY MUSIC COMPANY**, (See Jusko, Ralph, Publications, Inc.)

H

**HACKETT, BOBBY**, 34-21 84th St., Jackson Heights, N. Y. 11372

**HALL & McCREARY COMPANY**, (See Schmitt, Hall & McCreary Co.)

**HALL MUSIC COMPANY, THE**, (See Tennessee Music & Printing Co.)

**HANS, WILLY**, (See "IPA")

**HANSON, EDDY**, (See National Music Company, Inc.)

**HARBOT MUSIC**, 1513 Hawkins Street, Nashville, Tennessee 37203

**HARTFORD MUSIC COMPANY, THE**, Powell, Missouri, 65730

**HART'S MUSIC COMPANY**, (See National Music Company, Inc.)

**HARVEST TIME PUBLISHERS**, P. O. Box 8073, Nashville, Tenn. 37207

**HATHAWAY, FRANKLIN EARL, MUS. PUB.**, c/o Natl. Music Co., Inc., 77 West Washington St., Chicago, Ill. 60602, including: GOSPEL MUSIC PUBLICATIONS

**HAWKINS, FLOYD W.**, (See Lillenas Publishing Company)

**HENSON, J. M., MUSIC COMPANY**, Briarcliff Hotel, 1050 Ponce de Leon Avenue, N. E., Atlanta, Georgia, 30383, including: MORRIS-HENSON MUSIC COMPANY, SOUTHERN MUSIC PLATE COMPANY

**HERITAGE MUSIC PUBLICATIONS, INC.**, (See Century Music Pub. Co., Inc.)

**HESS, W. JAKE**, 401 Williamsburg Rd., Brentwood, Tenn. 37027

**HIGHLAND MUSIC COMPANY**, 1311 N. Highland Ave., Hollywood, Calif. 90028

**HORSETOOTH MUSIC & PUBLISHING COMPANY**, Savings Building, Suite 990, Fort Collins, Colorado, 80521

**HOWLIN MUSIC COMPANY**, 10,000 Santa Monica Blvd., Suite 311, Los Angeles, Calif. 90067

**HUFFER, FRED K.**, (See Schmidt, A. P. Co.)

**HUNTZINGER, R. L., INC.**, Lawson Court, P. O. Box 854, Cincinnati, Ohio 45201

**HYMNTIME PUBLISHERS**, (See Sinspiration, Inc.) including: STANPHILL, IRA

I

**IOZIKOWSKI, LEON**, (See "PWP")

**IDZIKOWSKI, M.**, (See "PWP")

**IMPERIAL PUBLICATIONS, INC.**, 401 Williamsburg Rd., Brentwood, Tenn. 37027

**INSPIRATION PUBLISHERS**, (See Paris, Oren)

**"IPA," ISRAEL PUBLISHERS AGENCY**, P. O. Box 4345, 7 Arlosoroff St., Tel-Aviv, Israel

**"ISCAM," ISRAEL SOCIETY OF COMPOSERS, AUTHORS & MUSIC PUBLISHERS**, (See "IPA")

**ISLAND MUSIC**, (See Zellner, Harry)

**IVES, DAVID L.**, (See Lillenas Publishing Company)

**IVES MUSIC PRESS**, (See Lillenas Publishing Company)

IN TAPE ACCESSORIES FOR THE NOW GENERATION  
LE-BO'S NEW TA-98 JUMBO CARTRIDGE CASE  
IS THE "747" OF THE CARRYING CASES



Perfectly engineered wood construction. Red flocked velvet interior, individual compartments. Holds 36 stereo cartridges. Leatherette Alligator finish in black or brown colors.  
**TA-98** SUGGESTED LIST \$15.95

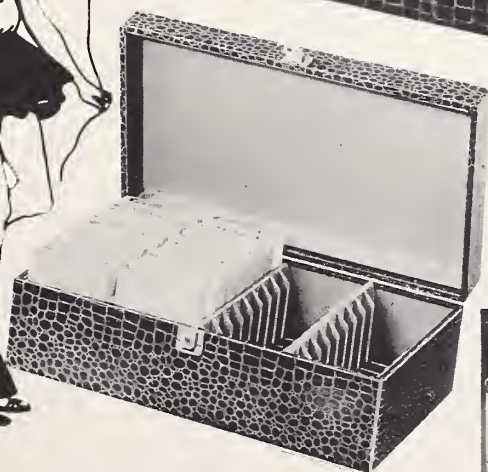
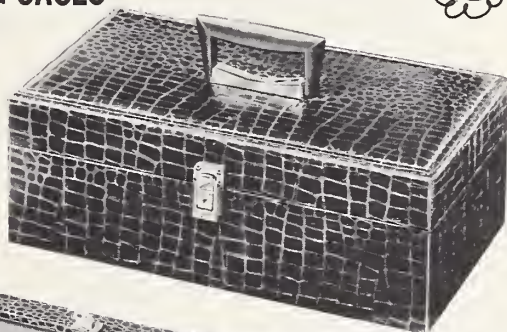

**Cat. #TA-11 TAPE HEAD CLEANER SPRAY**  
For all Cassette, Stereo 8 Cartridge Auto and Reel to Reel Players. \$1.50



**Cat. #TA-104** Brand new attractive inexpensive stereo cartridge carrying case. Psychedelic and flower designs. Holds 12 cartridges. SUGGESTED LIST \$4.95



**CAT. #TA-52**  
Deluxe Wood Tape Cartridge Carrying Case, Leatherette covered. Holds 15 Cartridges in individual compartments. Use for Stereo Cartridges. Attractive red velvet flocked interior. Individually packed. Black Crush, Alligator; Black, Brown, Red, Green, Blue, White.

SUGGESTED LIST \$9.95

**TA-54.** Same as TA-52. Holds 24 Cartridges or 96 cassettes.

SUGGESTED LIST \$11.95



**Cat. #TA-102** Brand new attractive inexpensive Cassette carrying cases. New psychedelic and flower designs. Holds 12 cassettes in individual slots.

SUGGESTED LIST \$3.95



**#C60-#C90-#C120** 60, 90 and 120 Minute Deluxe Blank Loaded Professional Cassettes. Polished Calendered, Tensitized Mylar Recording Tape. Flanged Guide Rollers on Stainless Steel Pins. Lubricated Wafers, Foil Leaders. For use with reversing machine.



**PRODUCTS CO., INC., 71-08 51st AVE., WOODSIDE, N. Y. 11377 THE LEADER WITH THE MOST COMPLETE LINE**

Sesac  
Publishers

**K**

**KA-COV MUSIC COMPANY**, c/o Harry Weber & Co., 271 Madison Ave., 7th Floor, New York, N. Y., 10016

**KANNER MUSIC PUBLISHING COMPANY**, (See Top Music Publishers, Inc.)

**KELLER, HAL**, (See Misty Music Publications)

**KELMAN MUSIC CORP.**, 470 West End Ave., Apt. 1E, New York, N. Y. 10024

**KENOOR MUSIC, INC.**, Delevan, N. Y. 14042

**KEYBOARD PUBLISHING COMPANY**, (See Century Music Pub. Co., Inc.)

**KING, K. L., MUSIC HOUSE**, Fort Dodge, Iowa 50501

**KING MUSIC PUBLISHING CORP.**, 351 West 52nd St., New York, N. Y. 10019, including: CARDILLI, M. V., CENTRAL MUSIC PUB. CO., CERRUTI, JOHN M., CLEF MUSIC CORP., LANE PUBLISHING CO., MCKINLEY PUBLISHERS, INC., ROMA MUSIC CO.

**KJOS, NEIL A., MUSIC COMPANY**, 525 Busse Highway, Park Ridge, Ill. 60068

**KRACHTUS, JOHN, COMPANY**, (See Vitak Elsnic Company)

**KRONE, MAX T. & BEATRICE P.**, 623C Avenida Sevilla, Laguna Hills, Calif. 92653

**KULKA MUSIC**, 665 Harrison St., San Francisco, Calif., 94107

**L**

**LAIR, JOHN**, Renfro Valley, Kentucky 40473

**LANE PUBLISHING CO.**, (See King Music Publishing Corp.)

**LANGOON MUSIC**, 1156 Striebel Road, Columbus, Ohio 43227

**LENA MUSIC, INC.**, c/o Nat Tarnapol, Brunswick Records, 445 Park Avenue, New York, New York 10022

**LILLENAS, HALDOR**, (See Lillemas Publishing Company)

**LILLENAS PUBLISHING COMPANY**, Box 527, Kansas City, Missouri 64141, including: HAWKINS, FLOYD W. (Only compositions as per list issued) IVES, DAVID L. (Only compositions as per list issued) IVES MUSIC PRESS (Only compositions as per list issued) LILLENAS, HALDOR (Only compositions as per list issued) NAZARENE PUBLISHING HOUSE, TEMPO MUSIC SERVICE

**LISTER, MOSIE**, (See Lister, Mosie, Publications)

**LISTER, MOSIE, PUBLICATIONS**, 11306 Carrollwood Drive, Tampa, Florida 33618, including: LISTER, MOSIE

**J**

**JASTRZAB, EDITION**, (See "PWP")

**JAWORSKI-PANOY MUSIC PUBLISHING COMPANY**, 142 Seymour Street, Hartford, Connecticut 06106

**JAYPAUL MUSIC CO.**, c/o Sidney H. Leitman, 1 East Post Rd., White Plains, N. Y. 10601

**JEFFRESS MUSIC COMPANY**, Crossett, Ark. 71635

**JEWELL, FRED, MUSIC COMPANY**, Worthington, Ind., 47471

**JIMICK, HARRY**, (See "IPA")

**JOAB MUSIC INC.**, P. O. Box 396, Nashville, Tennessee 37202

**JUSKO, RALPH, EDITIONS**, (See Jusko, Ralph, Publications, Inc.)

**JUSKO, RALPH, PUBLICATIONS, INC.**, 440 Main St., Cincinnati, Ohio 45201, including: GURLEY, ROBERT G., GURLEY MUSIC COMPANY, JUSKO, RALPH, EDITIONS

**LIT PUBLISHING COMPANY**, c/o Elgart, 55 East 74th St., New York, N. Y. 10021

**LITIG, FRANK, MUSIC PUBLISHING COMPANY**, (See Schmidt, A. P., Co.)

**LIURGICAL MUSIC COMPANY**, (See McLaughlin & Reilly Company)

**LLOYD MUSIC INC.**, 1416 N. LaBrea Avenue, Hollywood, Calif. 90028

**LOVE MUSIC**, 720 17th Ave., S., Nashville, Tenn., 37203

**LUDWIG MUSIC PUBLISHING COMPANY**, 557-67 East 140th St., Cleveland, Ohio 44110, including: CARLTON MUSIC PUB

**LUTHERAN PUBLISHING HOUSE**, (See Augsburg Publishing House)

**M**

**MACIEJOWSKI, ZB**, (See "PWP")

**MAHURIN, MELVIN E., PUBLICATIONS**, (See Prayerlight Recordings and Publications, Inc.)

**MARICOPA MUSIC COMPANY, INC.**, 713 18th Ave., South, Nashville, Tenn. 37203

**MARI-BO MUSIC**, c/o Confederate Records, Box 1550, Nashville, Tennessee 37202

**MAT-CO PUBLISHING COMPANY**, P. O. Box 6992, Nashville, Tennessee 37215, including: MATHEWS, JOHN

**MATHEWS, JOHN**, (See Mat-Co Publishing Co.)

**MCKINLEY PUBLISHERS, INC.**, (See King Publishing Corp.)

**McLAUGHLIN & REILLY COMPANY**, 1834 Ridge Ave., Evanston, Ill. 60204, including: CATHOLIC MUSIC COMPANY, LITURGICAL MUSIC COMPANY

**MELOOY-AIRE PRESS**, (See Singspiration, Inc.)

**MERCURY MUSIC CORP.**, Presser Place, Bryn Mawr, Pennsylvania 19010, including: MUSIC PRESS, INC., WEANER-LEVANT PUBLICATIONS, WEANER, MAXWELL

**MESSENGER PRESS, THE**, (See Augsburg Publishing House)

**MISTY MUSIC PUBLICATIONS**, 6034 Vantage Avenue, N. Hollywood, Calif. 91606, including: KELLER, HAL

**MOORE, OAVID**, (See Brumley, Albert E., & Sons)

**MORRIS-HENSON MUSIC COMPANY**, (See Henson, J. M., Music Company)

**MOSTI, JOE, ACCORDION MUSIC HOUSE**, (See Deiro, Pietro, Publications)

**MUSIC PRESS**, P. O. Box 1052 Tuskegee Institute, Ala. 36088, including: DAWSON, WILLIAM L.

**MUSIC PRESS, INC.**, (See Mercury Music)

**MUSIC PRODUCTS CORP.**, (See Palma Music Company)

**MUSICAL MELOOY PUBLISHERS**, (See Bava's, John, Music)

**MUSICTOWN PUBLISHERS**, 806 16th Avenue South, Nashville, Tennessee 37203

**N**

**NATIONAL MUSIC CO., INC.**, 77 West Washington St., Chicago, Ill. 60602, including: ALBRIGHT MUSIC COMPANY, BENDIX PUBLISHING CORP., BROADCAST MUSIC PUBLISHERS, CAPITOL MUSIC COMPANY, FAIRBANK, H. W., COMPANY, FORECAST MUSIC, FUTURE MUSIC, HANSON, EDDY, (Only compositions as per list issued) HART'S MUSIC COMPANY, POPULAR MUSIC PUBLICATIONS, SELECT MUSIC COMPANY, STANDARD MUSIC COMPANY, STANDARD SONGS, WINDSOR MUSIC COMPANY

**NAZARENE PUBLISHING HOUSE**, (See Lillemas Publishing Company)

**NEMMERS, M. L., PUBLISHING COMPANY**, 2936 N. Hackett Ave., Milwaukee, Wisc. 53211

**NETWORK MUSIC PUBLISHERS**, (See Top Music Publishers, Inc.)

**O**

**ORTLUND, MRS. ANNE**, 1190 S. El Molino, Pasadena, Calif. 91106

**P**

**PAGANI, O., & BRO., INC.**, 289 Bleeker St., New York, N. Y. 10014

**PAGE BOY PUBLICATIONS**, c/o Warner McPherson, 206 Bahia Mar Point, Hendersonville, Tennessee 37075

**PALLMA MUSIC COMPANY**, c/o Mr. Neil A. Kjos, Jr., Director, 525 Busse Highway, Park Ridge, Illinois, 60068, including: BABWIN PUBLICATIONS, MUSIC PRODUCTS CORP., PALLMA, FRANK, MUSIC PUBLISHER, PALLMA MUSIC PRODUCTS CORP., QUINCKE, WALTER A. (Only compositions as per list issued)

**PALLMA MUSIC PRODUCTS CORP.**, (See Palma Music Company)

**PALLMA, FRANK, MUSIC PUBLISHER**, (See Palma Music Company)

**PANELLA MUSIC COMPANY**, 58 Warren St., Apt. 2., Pittsburgh, Pa. 15205

**PARAGON MUSIC PUBLISHERS**, 71 Fourth Avenue, New York, N. Y. 10003

**PARIS, OREN**, 1407 Backus, Springdale, Arkansas, 72764, including: INSPIRATION PUBLISHERS, RIP-CHORD MUSIC CO.

**PARKS, J. A., COMPANY, THE**, 525 Busse Highway, Park Ridge, Ill. 60068

**PARR MUSIC**, 2917 Snowden Road, Nashville, Tennessee 37204

**PARRIS MUSIC COMPANY**, (See Stamps Quarter Music Company, Inc.)

**PARRIS, O. A.**, (See Stamps Quartet Music Company, Inc.)

**PAWNEE ROSE PUBLICATIONS, INC.**, 1513 Hawkins Street, Nashville, Tennessee 37202

**PEACH MUSIC**, 806 16th Ave., South, Nashville, Tenn., 37203

**YVONNE MARIE PEARROW**, 1918 Farragut Place, Jacksonville, Florida 32207

**PERKINS PUBLISHING CO.**, 1209 Saunders Avenue, Madison, Tennessee 37115

**PERRY, F. CLARK, COMPANY**, (See Tennessee Music & Printing)

**PETERSON, JOHN W.**, (See Singspiration, Inc.)

**PIONEER MUSIC PRESS**, 975 South West Temple, Salt Lake City, Utah 84101, including: WHEELWRIGHT, LORIN F.

**PODGORSKI, I.**, (See Podgorski, I., Music and Publishing Co.)

**PODGORSKI, I., MUSIC ANO PUBLISHING CO.**, 2233 Orthodox St., Philadelphia, Pa. 19137, including: PODGORSKI, I.

**POLSKIE TOWARZYSTWO MUZYKI WSPOLCZESNEJ** (See "PWP")

**POLSKIE WYDAWNICTWO MUZYKI WSPOLCZESNEJ** (See "PWP")

**POLYPHONIC PUBLICATIONS**, (See Schmidt, A. P., Co.)

**POMPANO MUSIC COMPANY**, c/o Jack Hooke, 1650 Broadway, Rm. 307, New York, N. Y. 10019

**POOLE PUBLISHING CO., INC.**, 11-A Lawyers Building, Greenville, South Carolina 29601

**POPULAR MUSIC PUBLICATIONS**, (See National Music Company, Inc.)

**POUNO RIGGE MUSIC CORP.**, 359 North Canon Drive, Beverly Hills, Calif. 90210

**PRAYERLIGHT RECORDINGS ANO PUBLICATIONS INC.**, 119 N. Pendleton Avenue, Pendleton, Indiana, 46064, including: MAHURIN, MELVIN E., PUBLICATIONS

**"PWP." POLSKIE WYOAWNICTWO MUZYCNE**, (See "PWP")

**"PWP." PRZEOSTAWICIELSTWO WYOAWNICTW POLSKICH**, (Association of Polish Publishers) Warsaw, Poland

**Q**

**QUINCKE, WALTER A.**, (See Palma Music Company)

**R**

**RAINBOW MUSIC COMPANY**, 1502 Woodland Drive, Okmulgee, Oklahoma 74447

**ROMALA MUSIC**, 1615 Homewood Place, Dallas, Texas 75224

**RAMSEY, WILL M.**, (See Central Music Company)

**RAMSEY & PARKER**, (See Firm Foundation Publishing House)

**RAYOEE MUSIC CO.**, The Nashville Office, P. O. Box 12023, Nashville, Tennessee 37212

**REAST, LINOSEY B.**, 1614 Sunset Terrace, Ft. Worth, Texas 76102

**REVIVAL MUSIC COMPANY**, P. O. Box 16, Searcy, Ark., 72143, including: WALLS, W. M.

**RICK MAR COMPANY**, Box 329, Hendersonville, Tennessee 37075

**RIP-CHORO MUSIC CO.**, (See Paris, Oren)

**ROAT, CHARLES E., MUSIC COMPANY**, (See Amsco Music Publishing Co.)

**ROMA MUSIC CO.**, (See King Music Publishing Corp.)

**RUDNICKI, WALERY**, (See "PWP")

**S**

**SACRED OESIGN ASSOCIATES, INC.**, (See Schmitt, Hall & McCreary Company)

**SAGE ANO SANO MUSIC, INC.**, 6520 Selma Ave., Hollywood, Calif. 90028, including: GALE MUSIC, SAGE AND SAND MUSIC PUBLISHERS

**SAGE ANO SANO MUSIC PUBLISHERS**, (See Sage and Sand Music, Inc.)

**SAJEWSKI, W. H., MUSIC & PUB. CO., INC.**, 1227 Milwaukee Ave., Chicago, Ill. 60622

**SAMELY, SAM**, (See "IPA")

**SAPIEYEVSKI, JERZY**, 6300 Lakeview Drive, Falls Church, Virginia 22041

**SCENE THREE PUBLICATIONS**, 320 Welch Rd. F-4, Nashville, Tenn. 37211

**SCHMIDT, A. P., COMPANY**, 1834 Ridge Ave., Evanston, Illinois 60204

**SCHMITT, HALL & McCREARY COMPANY**, 527 Park Ave., Minneapolis, Minnesota 55415, including: HALL & McCREARY COMPANY, SACRED DESIGN ASSOCIATES, INC., SCHMITT, PAUL A., MUSIC COMPANY, SCHMITT PUBLICATIONS, INC., SELMER, H. & A., INC. (Only compositions as per list issued)

**SCHMITT, PAUL A., MUSIC COMPANY**, (See Schmitt, Hall & McCreary Co.)

**SCHMITT PUBLICATIONS, INC.**, (See Schmitt, Hall & McCreary Co.)

**SCOTT-CARTER MUSIC**, P. O. Box 368, Valdosta, Georgia 31601

(Cont on next Page)

THE BEST IS ON  
**NASHBORO**

**ABET**

**CREED**

**Dasco**

**excela**

**NASHBORO**

1011 Woodland Street  
Nashville, Tennessee  
37206



LAND  
OF THE  
COUNTRY  
GIANTS





# REX ALLEN



**DL 75205**  
Available on 8-Track Cartridge and Cassette Tape.

# BILL ANDERSON

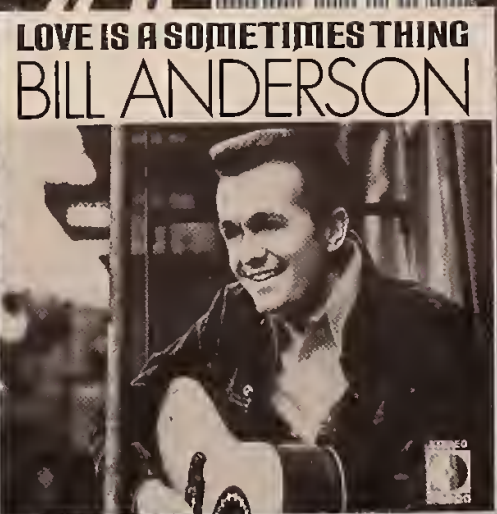
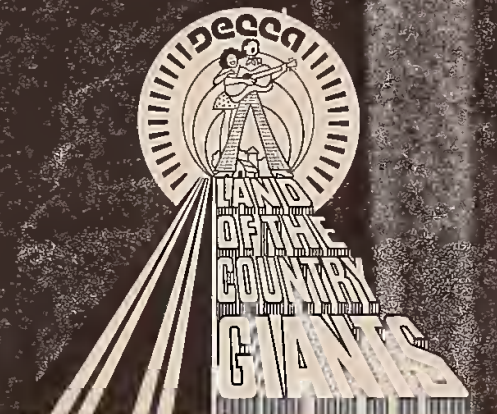

**DL 75206**  
Available on 8-Track Cartridge and Cassette Tape  
*Current Single:*  
**LOVE IS A SOMETIMES THING**  
32643

REX ALLEN • BILL ANDERSON • MARGARET BRIXEY • WILMA BURGESS • JIMMIE DAVIS  
JIMMY DICKENS • CLAUDE GRAY • JACK GREENE • BILL HOWARD • JAN HOWARD • WAYNE KEMP  
BOBBY LORD • LORETTA LYNN • WARNER MACK • GRADY MARTIN • JIMMY MARTIN • BILL MONROE  
JAMES MONROE • JIMMY NEWMAN • OSBORNE BROTHERS • BILL PHILLIPS • DEBBIE LYNN PIERCE  
WEBB PIERCE • LaMELLE PRINCE • JEANNE PRUETT • JEANNIE SEELY • SLEWFOOT FIVE • JERRY SMITH  
PEGGY SUE • TEXAS TROUBADOURS • ERNEST TUBB • CONWAY TWITTY • JIMMY WAKELY • JOHN WAKELY  
JAY LEE WEBB • KITTY WELLS • WILBURN BROTHERS • MARION WORTH • BOBBY WRIGHT • JOHNNY WRIGHT  
REX ALLEN • BILL ANDERSON • MARGARET BRIXEY • WILMA BURGESS • JIMMIE DAVIS  
JIMMY DICKENS • CLAUDE GRAY • JACK GREENE • BILL HOWARD • JAN HOWARD • WAYNE KEMP  
BOBBY LORD • LORETTA LYNN • WARNER MACK • GRADY MARTIN • JIMMY MARTIN • BILL MONROE  
JAMES MONROE • JIMMY NEWMAN • OSBORNE BROTHERS • BILL PHILLIPS • DEBBIE LYNN PIERCE  
WEBB PIERCE • LaMELLE PRINCE • JEANNE PRUETT • JEANNIE SEELY • SLEWFOOT FIVE • JERRY SMITH  
PEGGY SUE • TEXAS TROUBADOURS • ERNEST TUBB • CONWAY TWITTY • JIMMY WAKELY • JOHN WAKELY  
JAY LEE WEBB • KITTY WELLS • WILBURN BROTHERS • MARION WORTH • BOBBY WRIGHT • JOHNNY WRIGHT  
REX ALLEN • BILL ANDERSON • MARGARET BRIXEY • WILMA BURGESS • JIMMIE DAVIS  
JIMMY DICKENS • CLAUDE GRAY • JACK GREENE • BILL HOWARD • JAN HOWARD • WAYNE KEMP  
BOBBY LORD • LORETTA LYNN • WARNER MACK • GRADY MARTIN • JIMMY MARTIN • BILL MONROE  
JAMES MONROE • JIMMY NEWMAN • OSBORNE BROTHERS • BILL PHILLIPS • DEBBIE LYNN PIERCE  
WEBB PIERCE • LaMELLE PRINCE • JEANNE PRUETT • JEANNIE SEELY • SLEWFOOT FIVE • JERRY SMITH  
PEGGY SUE • TEXAS TROUBADOURS • ERNEST TUBB • CONWAY TWITTY • JIMMY WAKELY • JOHN WAKELY  
JAY LEE WEBB • KITTY WELLS • WILBURN BROTHERS • MARION WORTH • BOBBY WRIGHT • JOHNNY WRIGHT  
REX ALLEN • BILL ANDERSON • MARGARET BRIXEY • WILMA BURGESS • JIMMIE DAVIS  
JIMMY DICKENS • CLAUDE GRAY • JACK GREENE • BILL HOWARD • JAN HOWARD • WAYNE KEMP  
BOBBY LORD • LORETTA LYNN • WARNER MACK • GRADY MARTIN • JIMMY MARTIN • BILL MONROE  
JAMES MONROE • JIMMY NEWMAN • OSBORNE BROTHERS • BILL PHILLIPS • DEBBIE LYNN PIERCE  
WEBB PIERCE • LaMELLE PRINCE • JEANNE PRUETT • JEANNIE SEELY • SLEWFOOT FIVE • JERRY SMITH  
PEGGY SUE • TEXAS TROUBADOURS • ERNEST TUBB • CONWAY TWITTY • JIMMY WAKELY • JOHN WAKELY  
JAY LEE WEBB • KITTY WELLS • WILBURN BROTHERS • MARION WORTH • BOBBY WRIGHT • JOHNNY WRIGHT  
REX ALLEN • BILL ANDERSON • MARGARET BRIXEY • WILMA BURGESS • JIMMIE DAVIS  
JIMMY DICKENS • CLAUDE GRAY • JACK GREENE • BILL HOWARD • JAN HOWARD • WAYNE KEMP  
BOBBY LORD • LORETTA LYNN • WARNER MACK • GRADY MARTIN • JIMMY MARTIN • BILL MONROE  
JAMES MONROE • JIMMY NEWMAN • OSBORNE BROTHERS • BILL PHILLIPS • DEBBIE LYNN PIERCE  
WEBB PIERCE • LaMELLE PRINCE • JEANNE PRUETT • JEANNIE SEELY • SLEWFOOT FIVE • JERRY SMITH  
PEGGY SUE • TEXAS TROUBADOURS • ERNEST TUBB • CONWAY TWITTY • JIMMY WAKELY • JOHN WAKELY  
JAY LEE WEBB • KITTY WELLS • WILBURN BROTHERS • MARION WORTH • BOBBY WRIGHT • JOHNNY WRIGHT  
REX ALLEN • BILL ANDERSON • MARGARET BRIXEY • WILMA BURGESS • JIMMIE DAVIS  
JIMMY DICKENS • CLAUDE GRAY • JACK GREENE • BILL HOWARD • JAN HOWARD • WAYNE KEMP

# JIMMIE DAVIS



LAND  
OF THE  
COUNTRY  
GIANTS



**DL 75199**

Available on 8-Track Cartridge and Cassette Tape

# JACK GREENE



LAND  
OF THE  
COUNTRY  
GIANTS



**DL 75208**

Available on 8-Track Cartridge and Cassette Tape

*Current Single:*

**THE WHOLE WORLD COMES TO ME  
32699**

# Owen Bradley: The Biggest of The Country Giants

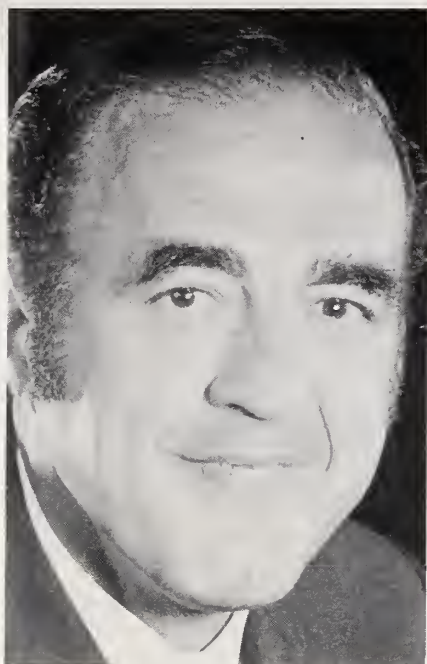

By **TONY MARTELL**,  
Vice President Marketing  
and Creative Services

To create a "Land of Country Giants" such as Decca Records has, requires a giant working behind the scenes. Decca Records has that "back-stage giant" in the person of Owen Bradley, Vice President and Director of A & R for Country Product.

A giant, according to one Webster definition, is: A person of extraordinary ability, courage, strength, etc. Regardless of who defines the term, Owen Bradley eminently qualifies. A man of average height (at least two of his artists tower high above him), he stands head and shoulders above the average in terms of talent and humanity.

## UP FROM ROCK 'N ROLL



By Conway Twitty

In this day and time when many country artists are looking for that big record that will "go pop", I guess I'm unusual. I started out in rock and roll and worked my way up to Country.

All the time I was singing rock and roll, I wanted to record Country. I even asked the label I was recording for at the time to let me do Country under my real name (Harold Jenkins). But it took the courage of Owen Bradley to let me do my first real Country recording sessions.

Once during the R & R days, I stopped by WSM Radio to visit with Ralph Emery on his all-night show. I was thrilled over a Ray Price recording of one of my songs, WALK ME TO THE DOOR. I told Ralph of my desire to sing Country, and he really didn't

As a producer of hit recordings, he has an uncanny ability to recognize the potential of a song and to match it with just the right artist at just the right time. The national trade listings of Country singles and albums testify to his phenomenal success. In an industry where the only constant is constant change, Owen Bradley-produced singles and albums are continually represented among the national best sellers and at the top of the Country charts.

While keeping a roster of successful artists in sales contention, he has managed to nourish and build a new group of superstars. Realizing that all artists eventually reach a plateau in sales, Owen has insured the future success of our Country artists by constantly grooming promising young talent. The very number of artists with which he is involved and whose careers he is helping to build is staggering. Yet each of them gets his full share of attention and effort. A lesser man would have stumbled under the load years ago, but with Owen the challenge of this millstone is the excitement and stimulation of his life.

A wise man once said, "If you have something that must be done, give it to a busy man". Owen Bradley is proof of the truth in this philosophy. In addition to his duties to Decca and the artists he records, he manages to find time to devote to various civic organizations, fund-raising projects and industry organizations. A gifted businessman, he always has time to give novices in the industry the benefit of his experience and knowledge. Many musicians and artists and executives are where they are today in the industry because of advice they received from Owen.

One of the innovators of the fabled "Nashville sound," Owen is a fascinating personality in the recording studio. His personal creativity and knowledge of music, along with his acute understanding and ability to work with people, have earned him the respect of his artists, the studio technicians and the musicians who create the sound and atmosphere for which Nashville has become famous. He inspires everyone involved to be happy with nothing less than the best they can give.

In the opinion of friends (and this includes every artist on his roster, and artists on other labels as well), associates and students of Nashville recording, there is no question that, as the plaque awarded him by Decca during the recent Country sales meeting attests, Owen Bradley is the "Biggest Country Giant Of Them All".

believe I could, although IT'S ONLY MAKE BELIEVE was and still is a favorite with the Country audience. He handed me a guitar and said, "Okay, Conway, show me you can sing Country." So I did. I sang every Hank Williams song I could think of. He still talks about it every time I go to see him. I had a ball that night!

And I still enjoy singing Country songs and performing for Country fans. I can't really say I ever enjoyed working on a rock and roll show. The music was too loud. The audience was too loud. I don't think they every heard a word I sang. On Country shows, I feel that I'm really communicating with the audience. It's a two-way street and that's the way I like it.

At any rate, I feel quite at home in Country music. It's where my roots are. And I'm grateful to Owen Bradley and Decca Records for giving me this chance to do what I've always wanted to do. I appreciate, too, the acceptance by the fans and the industry.

In case anyone wonders, as far as I'm concerned I'm home to stay.



THE MAN



THE FACTORY



**THE BRASS:** During the recent Country sales meet in Nashville, Decca execs honored Owen Bradley with a plaque which read: "To Owen Bradley, The Biggest Country Giant Of Them All — In Appreciation." Left to right are: Mike Maitland, president of MCA Records; Owen Bradley; Tony Martell, vice president of merchandising and creative services, and Jack Loetz, vice president Decca Records.

# The Country Is Growing By Leaps And Bounds



**THE PROMOTION**

The reason for the success of Country music is attributed to the fact that it's perhaps the easiest way to communicate feelings and the facts of life to "the people". Country music is native to America. All other music has evolved from Country roots.

The most outstanding quality about Country music is its utter simplicity in telling a story. It can be understood by the masses and is the most easily understood the world over—as evidenced by the great acceptance of the Nashville sound in Japan, Ireland, Germany, Finland—even England.

In the United States, Country began to establish national and metropolitan roots during World War II when Southerners migrated to the Eastern and Northeastern industrial centers.

The trend we have experienced in the last 15 years can only be accelerated as changes occur in listening audiences and geography. The more exposure Country gets, the more fans it draws into its following. This is in no small way due to the inroads such Country greats as Johnny Cash, Eddy Arnold, Loretta Lynn, Conway Twitty, and Jimmy Dean—and even more recently Glenn Campbell—have made into Pop-oriented audiences via television and radio exposure.

Major Country acts are no longer limited to bowling alleys and county fairs—they no longer have to work only rural areas. Thanks to the showcasing and popularizing of Country product by Cash and Campbell, a program of Country music can fill even Madison Square Garden to SRO.

During my 12-year membership in the Country Music Association, I have watched Country music progress to unbelievable heights. We have witnessed Country music attain a position



by **JACK LOETZ**

**Decca Records  
Executive Vice-President**

in American and international music that we never thought possible eight years ago.

Nashville has truly become Music City, U.S.A. It has gotten to be such a mecca for Pop artists that it is tough for Nashville's Country natives to get studio time booked. The Grand Ole Opry has become a landmark. The Country Music Museum and Hall of Fame, financed and constructed by the CMA, is one of the most popular tourist attractions in the South—in the nation, as a matter of fact. It has become so popular that the Hall of Fame grounds and building are being expanded to accommodate the annual deluge of visitors.

The CMA has also helped to broaden the appeal of Country product and is responsible for many Pop stations turning their operation in profit-making centers through the full or part-time programming of Country music.

One of the leading developers of Nashville into Music City, U.S.A., and Country music into the epic proportion it has reached today is Owen Bradley. And this brings me to Decca and its "Land of the Country Giants". As the mass appeal of Country grows and grows at faster rates, Decca will continue to expand and expand its promotion and merchandising. We will continue to seek new talent for our roster and to implement new ideas in our recordings.

I am positive that Country music will grow by even more fantastic leaps and bounds. And I can tell you that Decca will continue its policy of being a forerunner in this all important and exciting facet of our industry.

## BEING FIRST WAS FUN (or, WHAT EVER HAPPENED TO BABY FATS?)



by **Jimmy Davis**

Some 35 years ago when I was in Shreveport, Louisiana, a man by the name of Jack Kapp called me from New York. He said he heard me on radio and wanted to know if I would like to audition for a recording contract. I found out later he was President of Decca Records.

I asked him where I would go audition. He said, "Chicago, the next week..."

I didn't own an automobile because I owed everybody while I was trying to finish Louisiana State University. So, I rented an old car (that burned 34 quarts of oil the first 300 miles) and was on my way to Chicago.

I walked into the recording studio (a hotel room) without knocking, where Jack and Dave Kapp were trying to revive a big fat woman (with the cutest baby face I had ever seen) who had fainted while trying to hit a high note. I said to the two boys who were with me, "Let's stick with the low ones."

I recorded four songs—one of them was "Nobody's Darlin'", which happened to hit. Nobody, not even Decca or me, remembers what the other three were.

Decca didn't look like they were too well heeled, so I told them if it would help them in their venture, they could just pay me when times got better, for I'd never had anything anyway. Well, it seemed that everybody who tried out for Decca hit the jackpot, and my check came in and they've been coming in ever since. And, Decca soon had a pile of money that a show dog couldn't jump over—and business at Decca has consistently grown bigger and bigger.

I took the money from "Nobody's Darlin'" and bought a farm that now connects two municipalities—Shreveport and Bossier City.

I was lucky later with the recording of such songs as: "Columbus Stockade Blues", "Worried Mind", "It Makes No Difference Now", "Where The Old Red River Flows", "You Are My Sunshine" and scores of others.

I had always wanted to record gospel songs and hymns, so Decca was kind enough to bear with me. And, my

first one, "Someone To Care", was far better than I ever hoped for. So was "Supper Time", "One More Valley", "How Great Thou Art", and enough more to fill twenty albums.

I have a lifetime contract with Decca Records and when this is over they have promised to give me another one. They must like the fact that I've always come in "in the black". But it's the public I must truly thank. They always stood behind me—even in the lean years. Without them, I couldn't have ever made it as a record star—or as a politician!



**THE STAGE**

# JAN HOWARD

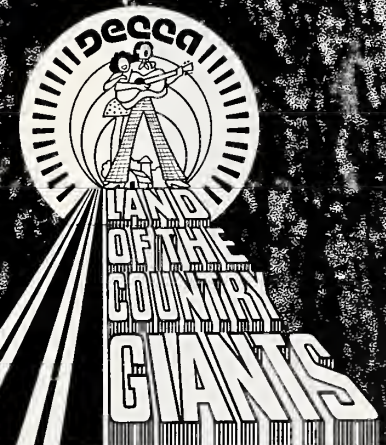
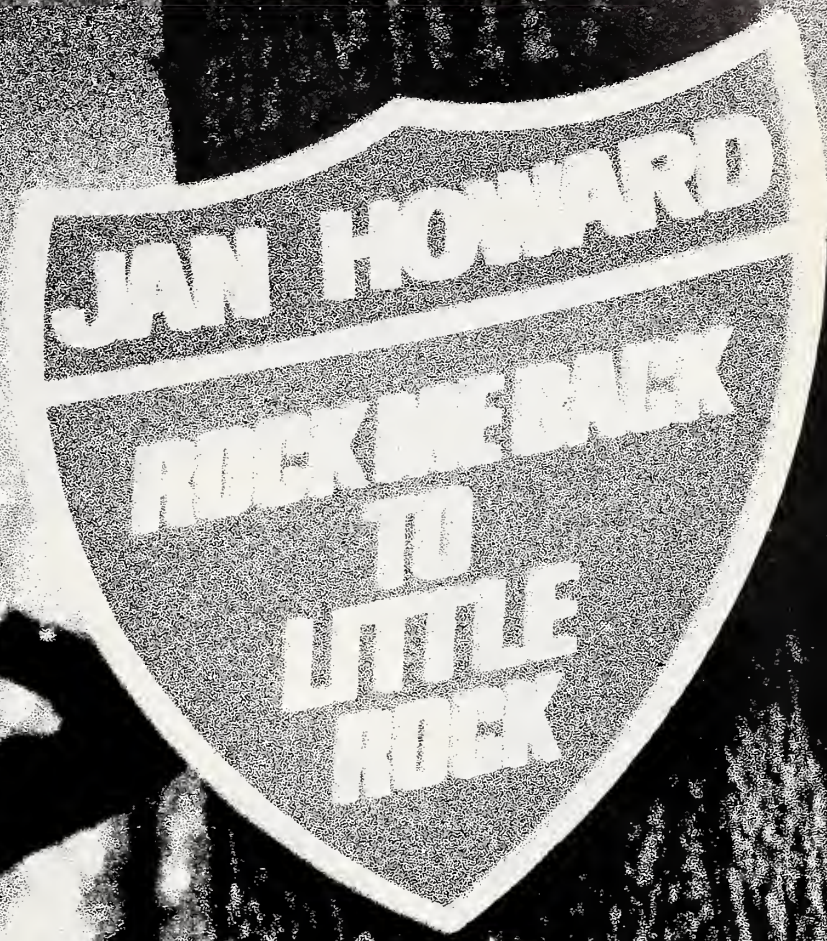

**DL 75207**  
Available on 8-Track Cartridge and Cassette Tape  
*Current Single:*  
**ROCK ME BACK TO LITTLE ROCK**  
32636

# LORETTA LYNN



Loretta Lynn Writes 'Em And Sings 'Em



**DL 75198**

Available on 8-Track Cartridge and Cassette Tape

*Current Single:*

**YOU WANNA GIVE ME A LIFT**

**32693**



# WARNER MACK

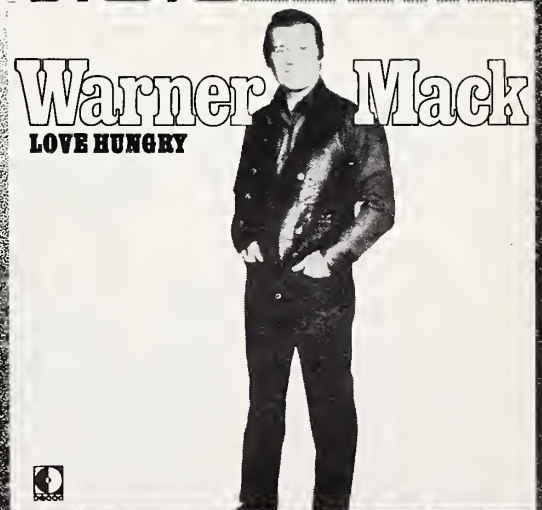

**DL 75219**

Available on 8-Track Cartridge and Cassette Tape

*Current Single:*

**LOVE HUNGRY**

**32646**

# Let's Talk Country Promotion

# Let's Talk Country Sales



by Gene Kennedy

**National Country Promotion Manager  
Decca Records**

Since I've been in the Land of the Country Giants for only a few short weeks, I consider it a distinct honor to be already considered an authority on Country promotion. Decca Records has long been recognized as a leader in the Country record industry; and I'm especially excited about the opportunity they have given me.

The promotion man's job just starts when he calls on a radio station. In order for him to do the complete job, he has to know his market, know the program directors, music directors, and disc jockeys at all stations in his territory. Additionally, he must know the sales potential of each type of record, whether Country, MOR, rock, R & B or classical. He has to stay in constant touch with all record outlets. In order to build an image for the label he is representing, the promotion man must first build a rapport for himself with the people he calls on. No matter how great the company

he is representing, the service he gives, the follow-through (and this is so vital) will determine the reputation of the label in his area. The company is only as good as the people who represent it. All available information he has about the product he is representing and what is happening in other markets should be passed on to the radio stations and record outlets in his market so they are completely informed about what is happening.

It has been said that Country promotion is easier than pop promotion. Maybe this is true and maybe it isn't. The one thing a promotion man, who is working all types of product, should keep in mind is that Country stations need and must have the same type of service and respect as any other type of station.

Country music is happening today bigger and better than ever before because of a lot of hard work by a lot of devoted people. As these same people keep working harder, and we add new people with the same kind of enthusiasm, it can only get bigger.

With the promotion of Chic Doherty to National Country Sales Manager and my appointment as National Country Promotion Manager and our not being involved in any other areas, Decca Records has once again proven its leadership in the Country field. If there is a trend in music today, it is toward more and more appreciation for and acceptance of Country music.

Decca has a field force dedicated to the success of Country product, and we intend to stay ahead of the trend and to help everyone involved in the marketing of recorded product take full advantage of the ever-increasing market for Country records and tapes.



by Chic Doherty

**National Country Sales Manager,  
Decca Records**

The combination of good product, enthusiasm and hard work spell plus sales of Country records and tapes just as it does in other areas of our business. We, at Decca, are fortunate enough to have an abundance of good product; and I consider it a privilege and a golden opportunity to be in the position to do all I can to help generate the enthusiasm and encourage the necessary effort to take advantage of the sales potential of that product.

The Country music market has moved to town. It is no longer confined to the rural areas of the world. The buying public, like the Country performing artists, is now drawn from all levels of society. They have more money for leisure activities and they spend it at personal appearances and for records and tapes. It's our business to see that those records and tapes are available to them when they want to buy.

Decca records has long been a major factor in the production, promotion and sale of Country product; and the steps the label is taking to strengthen the total organization are very timely. They are expressly designed to take advantage of an ever-changing, growing market for the excellent product which we represent. It is only natural that Decca should be in the forefront of the movement to gain new inroads into the Country record market.

With the extensive popular growth of Country radio and the increasing exposure of Country artists and music on national television, this is one of the most exciting sales eras I have known in my many years of selling Country product. In the relatively new area of cartridge and cassette tapes, Country recordings have already experienced great success. As a result of this industry innovation, the Decca catalog is experiencing a rebirth. We must apply all that we know and all that we can learn toward taking advantage of this young and growing outlet for our product. In view of all this excitement, I am tackling my new assignment with Decca with all the pleasure of a child with a new toy.

As I see it, the industry is at the dawning of a new day for Country record and tape sales. There are numerous opportunities to break through and build new artists. Decca has established solid ground in that area in the person of the remarkable Owen Bradley. These new opportunities require some calculated risks and a coordinated direction to insure that promotion and sales work together.

Gene Kennedy, in his new position, and I intend to work very closely together to coordinate promotion with Country radio stations and sales wherever records and tapes are sold. It is our intention also to encourage the growing trend for retail outlets to work closely with Country radio and to help these outlets profitably stock and merchandise product on an ever-increasing scale.

The market and demand are there and if we promote and merchandise to reach them, it can only mean more business. And Decca plans to do just that!

## COUNTRY MUSIC ON THE CONTINENTS — IN A BIG WAY

by Dick Broderick

**Vice President, MCA Records  
International and International Director,  
Country Music Association**

The importance of Country music in the international markets is a fact of the business. MCA Records International, drawing on the many talents from Nashville (and on Nashville's multi-talented Owen Bradley), has been accentuating the positive with an expanding program of Country album releases in all overseas markets.

Highlighting this campaign was the recent appearance of Loretta Lynn at Wembley Stadium in London and the more recent concert tour of En-

gland, Ireland, Sweden, Holland, Norway and Germany by the "MCA All-stars," a show featuring Loretta, Conway Twitty, Bill Anderson and Jan Howard, Peggy Sue and the Wilburn Brothers. The tour sparked marked sales increases of all the MCA Country product throughout Europe. And there was even the added honor of Loretta being voted "best Country female vocalist of the year" by the British Country Music Association. It was a family affair in a way: Peggy Sue, Loretta's younger sister, was voted "most promising new female singer."

Throughout 1970, MCA Records International will stress Country product with their affiliates around the world. One of my main goals for the year

will be the development of the Nashville Sound on the international scene. The program we now have in the planning stages calls for a Country tour of the Far East with dates in both Japan and Australia—two of the popularity strongholds for Country.

Country has established itself in Europe and in the Far East already and now it is beginning to take hold in South America—where we are expecting big things to happen. And England's little ball of fire Leapy Lee has been a sensation in his own country and also in the States with his exciting Country releases.

At MCA Records International our byword for success has become: "Country—Owen Bradley style"!



LEAPY LEE ON STAGE



PEGGY SUE



**THE TOUR:** Decca artists gather prior to recent tour of Europe for MCA Records International. Left to right: Doyle Wilburn; Loretta Lynn; Conway Twitty; Jan Howard; Bill Anderson; Peggy Sue; and Teddy Wilburn.

# JIMMY MARTIN

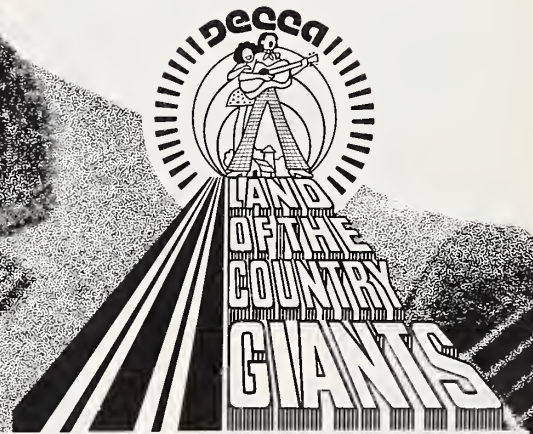

SINGING ALL DAY AND DINNER ON THE GROUND  
with **JIMMY MARTIN**  
AND THE SUNNY MOUNTAIN BOYS



**DL 75226**

Available on 8-Track Cartridge and Cassette Tape

*Current Single:*  
**(I've Got My) FUTURE ON ICE**  
32674

# OSBORNE BROTHERS

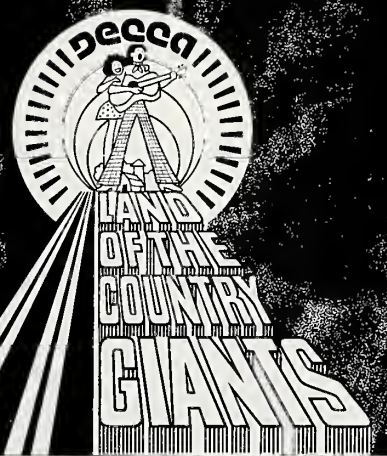

*Decca*  
The Osborne Brothers



**DL 75204**

Available on 8-Track Cartridge and Cassette Tape

*Current Single*

**LISTENING TO THE RAIN**

**32680**

# JEANNIE SEELY

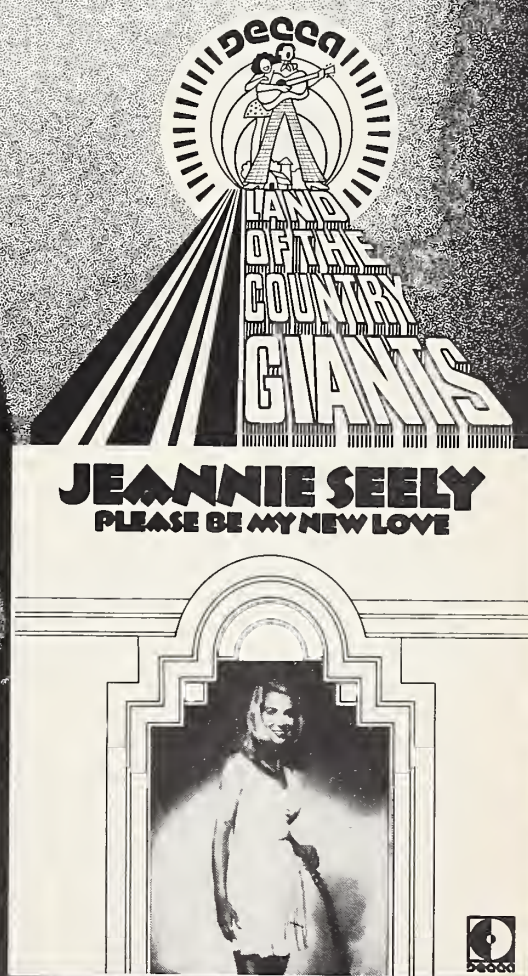

**DL 75228**

Available on 8-Track Cartridge and Cassette Tape

# You Can Take Western Out Of The Country . .

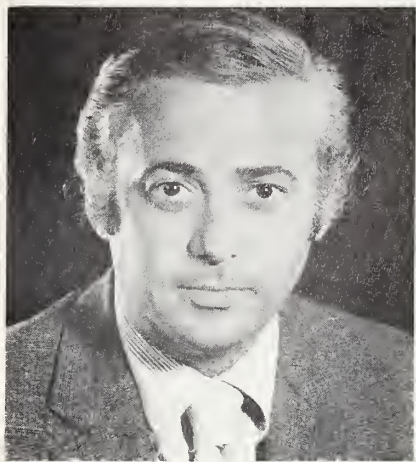

By Bill Levy  
Director of Creative Services

Boots and saddles are back in the Universal prop department, fringed jackets have gone to rock and spurs to Hell's Angels. It was inevitable. "Country" and "Western" have parted. Amiably, nevertheless, parted. Country music has simply become too big for C & W type casting. Especially when casting type. No longer must a country ad or album cover look country. I don't necessarily mean overly contemporary designs—but now that Country music has sort of "gone up town", the graphics must, too.

We're all basically in the business of sales. And if what we do visually can enhance the saleability of a package, then we've done our job. After selling \$1,500,000.00 worth of product during Loretta Lynn's January promotion, we could have let Loretta rest on her laurels in preparing her June LP. Instead,

we flew her to New York for a "new look" photography session. We even called in one of the top theatrical cosmeticians and stylists for the occasion.

We flew Bill Anderson to Los Angeles for photography at Universal City studios, then followed Conway Twitty, Peggy Sue, and Ernest Tubb to Houston to be photographed at the "world's largest country dance". We also travelled in Jack Greene's bus, gathering shots for his unprecedented full-color gate-fold "Greatest Hits" album. Jerry Smith made it big with his first Decca release, the non-country sounding, "Drivin' Home". We followed up with non-country looking full page ads.

And so it goes. Supporting artists every day in many ways. Different strokes for different folks. Make that different strokes for different Country folks. And it's a big Country!

## THE COUNTRY AUDIENCE—THE SAME ONLY DIFFERENT

By LORETTA LYNN

I have just come back from a concert tour of Europe with Conway, Bill

and Jan, Doyle and Teddy Wilburn and sister Peggy Sue. I found out one thing—the same thing I've been find-

ing out everywhere I go: People are pretty much the same everywhere you go.

They may not understand what the heck you're up there singing about, but they sure must be able to feel it—you can see that much in the expressions on their faces and in the way they shout and applaud. People all over the world have the same desires, needs and disappointments—the folks in Oslo, Norway, are very similiar to the folks in Louisville, Kentucky. They enjoy music that tells them how they feel in London just as much as they do in Charlotte.

There are many secrets to successful communication with your audience—and I am not about to tell you all of mine. I think the key to this communication is to be honest with them—tell it like it is. Let them know you understand what they feel and how they feel it. I guess the big secret is to make them believe—to convince them—that you're not just singing about it, you've been there, too. (It's not hard to do when you really have been there and they know it.) But, above all, tell your audience about it simply and without pulling any punches.

If you're going to sing about a bar-room, make them see it, feel it, even smell it. Transport them mentally to a bar. The same holds true for any other subject. Never take a real situation and make it into a fairy tale—they'll know you're putting them on and tear you up in a minute!

Country music is my life. I guess I love to sing more than anything else in life (next to my family, that is!). There is nothing greater than the communication, feeling, love and warmth I establish with my audiences. When I sing a sad number and I start to cry, I know I have reached the hearts of the folks out front when I see them dab their eyes with a hanky or rub their noses with a hand (and those men are the worst: they always try to hide the fact that you got through to them!).

Country singing is love when you get right down to the nitty gritty of it all. And emotion. And feeling. I always try to be just myself in the songs I write and in the way I sing them. I love people and I love performing for them.

Living on a bus can be mighty close quarters and some of the rules we have to follow seem quite stupid. But in the long run they work and we learn to stay out of each other's way—you get to know when the company wants company and when they want to be alone to think and write. The nicest thing is that we are all one big happy family on The Loretta Lynn Show. That's an important thing, too. Yes, we work hard, tough grinds, but it is satisfying. That makes it all worth while.

When we do a show, we have lots of fun, too—and we want everybody in the audience to have fun with us. They usually do—even when they cry!

## DECCA: COUNTRY CHART TOPPERS OF THE SIXTIES

Being No. 1 in the Country market is something of a habit at Decca Records. The Sixties, not long gone, were particularly happy years for Decca's artists and below is a list of singles and albums which earned their No. 1 place on the Cash Box charts along with the issue date they arrived.

### SINGLES

1. **I FALL TO PIECES**  
Patsy Cline (July 15, 1961)
1. **CRAZY**  
Patsy Cline (December 23, 1961)
1. **SHE'S GOT YOU**  
Patsy Cline (March 31, 1962)
1. **MAMA SING A SONG**  
Bill Anderson (October 6, 1962)
1. **STILL**  
Bill Anderson (March 23, 1963)
1. **8 X 10**  
Bill Anderson (October 12, 1963)
1. **HELLO VIETNAM**  
Johnny Wright (October 30, 1965)
1. **YOU AIN'T WOMAN ENOUGH**  
Loretta Lynn (August 13, 1966)
1. **THERE GOES MY EVERYTHING**  
Jack Greene (December 31, 1966)
1. **DON'T COME HOME A-DRINKIN'**  
Loretta Lynn (February 4, 1967)
1. **FOR LOVING YOU**  
Bill Anderson & Jan Howard (December 30, 1967)
1. **FIST CITY**  
Loretta Lynn (April 13, 1968)
1. **NEXT IN LINE**  
Conway Twitty (November 2, 1968)
1. **UNTIL MY DREAMS COME TRUE**  
Jack Greene (March 8, 1969)
1. **DARLING YOU KNOW I WOULDN'T LIE**  
Conway Twitty (March 27, 1969)
1. **WOMAN OF THE WORLD**  
Loretta Lynn (April 26, 1969)
1. **TO MAKE A MAN**  
Loretta Lynn (September 27, 1969)

### ALBUMS

1. **LORETTA LYNN**  
Loretta Lynn (May 16, 1964)
1. **YOU AIN'T WOMAN ENOUGH**  
Loretta Lynn (November 26, 1966)
1. **THERE GOES MY EVERYTHING**  
Jack Greene (February 25, 1967)
1. **ALL THE TIME**  
Jack Greene (September 23, 1967)
1. **FIST CITY**  
Loretta Lynn (June 15, 1968)

Note: Decca is sustaining it's No. 1 tradition in the Seventies with two top singles already this year, Loretta Lynn's "Wings Upon Your Horns" (February 7, 1970) and Conway Twitty's "Hello Darlin'" (May 25, 1970).



**THE GREAT . . .** The late great Patsy Cline who contributed so heavily to Decca's No. 1 performance in the Sixties.



# PEGGY SUE

market is  
Decca Rec-  
ords were  
Decca's  
singles  
No. 1  
along

H  
NG  
KIN'  
RUE

I  
p  
a  
y  
o

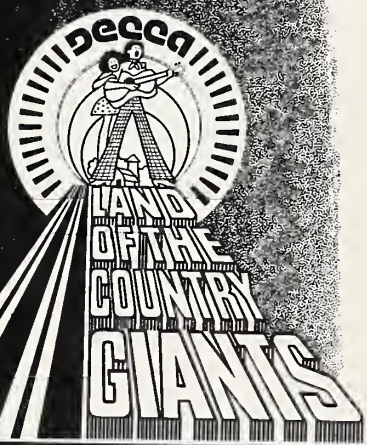

**DL 75215**

Available on 8-Track Cartridge and Cassette Tape

*Current Single:*  
**ALL AMERICAN HUSBAND**  
**32698**

# CONWAY TWITTY



LAND  
OF THE  
COUNTRY  
GIANTS

Conway  
Twitty  
hello  
darlin'



DL 75209

Available on 8-Track Cartridge and Cassette Tape

Current Single

HELLO DARLIN'

32661



# KITTY WELLS

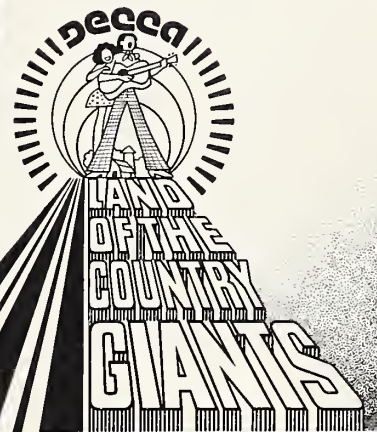

*Singing  
'em  
Country*  
**Kitty  
Wells**



**DL 75221**

Available on 8-Track Cartridge and Cassette Tape

*Current Single:*  
**YOUR LOVE IS THE WAY**  
32700

## HELLO, NEIGHBORS: HITTING THE ROAD AGAIN



By **KITTY WELLS**  
(MRS. JOHNNY WRIGHT)

Sometimes you arrive in a town and you see a banner hanging across the main street or a large poster saying, "Welcome Kitty Wells — the Queen of Country Music" — and you look around you at all the tired faces as you bump along and peek out the window at all the folks wondering "Who's the stranger?" and let me tell you: **YOU DON'T REALLY FEEL LIKE A QUEEN.**

There are many times when I don't feel like royalty. One of the few times that I do is after a song in some far-away place when the audience gets to their feet and applaud and shout their approval. This embrace from people I don't even know, but people I love so dearly, is all the royalty I'll ever want. There is nothing like a satisfied audience — nothing in the world.

Satisfaction has become a big part of my musical life with Johnny. We try to give it — and we sure do love to get it from them when we do. We have been working the road for over 25 years. These have been very wonderful and rewarding years for us. The only really bad part was that we had to leave the children at home. The summer months, however, are great because then they could travel with us. Oh yes, they were always a part of the show. All three — Ruby, Bobby and Carol Sue — have always enjoyed getting their feet wet out there on the stage. They are happy when they entertain. Happiness is important, no matter what you do in life. I guess Country artists can appreciate this most for there is nothing better than working before a grand bunch of people — and that's what Country audiences are.

Ruby and Carol Sue were recorded as a duet when they were barely in their teens. Bobby also recorded as a single when he was in his late teens. After high school Ruby and Bobby began traveling as regulars with the show, then Bobby moved out to California where he played the part of "Little Willie" for four years in the popular television series "McHale's Navy."

All three of the "kids" are married now and have families of their own. Ruby still works the road with us and all the children — and grandchildren — appear with us from time to time on our syndicated television show.

I must admit that the road gets hectic at times, especially when you travel 200 days out of a year and on some of those days you have to cover seven to eight hundred miles to the next concert. But the applause and appreciation we get from our fans makes the sleepless hours and driving — worthwhile. We have never been able to get over how we are treated when we arrive. The Decca promotion men take us to visit the DJ's who have helped make us what we are today. And, let me tell you, there is nothing like a Country DJ to really make you feel at home. It's nice to know they remember — that they still care.

## ARE COUNTRY SONGS REALLY THAT DIFFERENT?



By **BILL ANDERSON**

When people ask me what I believe to be the greatest attribute a Country music songwriter can have, I usually surprise them by answering, "empathy".

I say this because a Country song is by and large a song about people . . . about their feelings, their emotions, their dreams, and their failures. A Country song is primarily based on lyrical content rather than on a beat or a sound. Its purpose is to "communicate" . . . to say something that its listener can identify with . . . to establish a "people to people" relationship. And for a Country writer to write this type of song he'd either have to have done an awful lot of "livin'" (which he may have!!!) or know and understand the innermost feelings of those who have.

Skeptics have been heard to say that Country songs only have three themes: booze, love triangles and the impoverished conditions into which one was born. Country themes, in reality, are as wide and varied as the scope of life itself. Truck driving songs, novelty songs, the ever-present songs with religious or moral overtones, and on a lesser scale perhaps than in the other field of music, Country music also has its "message" songs.

The difference here is that Country songs don't usually carry the same message as their pop field cousins. While others are protesting wars, glorifying drugs, and bidding with adults to understand the younger generation, the hard-core Country fan prefers to identify with Merle Haggard and his pro-establishment "Okie from Muskogee", "The Fightin' Side of Me", and more recently "Jesus Take a Hold". Country songstress Jan Howard recently dedicated an entire Decca album to "God and Country". Autry Inman had a country monster with the "Ballad of Two Brothers", the story of a younger boy whose anti-establishment views were altered by his older brother's death in Vietnam.

Country people and Country music have "come to town" all over America, but the farmer or the store-keeper or the lumberjack who came to his new urban environment from rural surroundings not only brought his music to the city but his set of basic values as well . . . his sense of good and bad, right and wrong, and his understanding of and his love for the simple things in life.

One of the primary reasons for the resounding upsurge in Country music popularity over the past few years must surely be that here amidst the confusion and chaos of our age, filtering down through the smog and the polluted air of our advanced civilization, can come a song that has something inside it that feels as refreshing as a good deep breath of the clean country air from which it came.

We have always considered our shows a family affair — and a family show. And the public still loves this type of entertainment!

## COUNTRY MUSIC IS THE REAL THING

By **JACK GREENE** and **JEANNIE SEELY**



We are living in an age of reality. It's only natural, then, that the popularity of Country music should be at its all time peak. This generation's love affair with reality is affecting all areas of life — even history is being re-written in a less mythical vein. But perhaps, this demand for honesty has had its greatest impact in the area of entertainment.

To be successful today, we are told by producers, directors, writers and performers, movies must reflect life as it is and people as they are. The same conditions seem to be decisive in the success of songs and performances on record and on personal appearances. And that's what Country music has always been about — real people singing honestly about real things!

There are many indicators some obvious and others more obscure, of the increasing acceptance and popularity of Country music and Country artists. At the top of the list, of course, are record sales. Many sales come from the juke box market but more and more record stores and department store record departments are stocking and selling Country product. At one time, only two or three record shops specializing in Country product stocked singles in Nashville. In recent months, a number of Country singles have begun to show up in chain stores' singles racks. In Cincinnati, Louisville, Dayton, and Columbus, one distributor has gone into a Country single racking operation in a big way. And it's paid off in increased sales.

Decca Records, which has been a giant in the Country record business for more than 35 years and is perhaps the only major label that has been successful with a Country-dominated artist roster, has recently promoted Chic Doherty to the position of National Country Sales Manager and named Gene Kennedy, National Country Promotion Manager. We, personally, believe this to be the beginning of a really concentrated effort to take advantage of the growing market for recorded Country product. We are particularly pleased that our label recognizes the potential of their Country department and with the respect it has for Owen Bradley, the genius behind Decca's Country success.



In another area, it really hasn't been too long ago that advertising agencies thought the only products Country artists could sell were snuff, chewing tobacco and patent medicines. Major agencies are now utilizing the talents of Country performers to sell such widely diversified products as chain saws, soft drinks, beer, heating and air conditioning units, various food items and dozens of other products.

The success of Country-programmed radio stations in major metropolitan areas is public knowledge. Many of these stations were nearly out of business before changing to a Country format as a last resort. As a result, they moved from nowhere to high ratings in their areas — often to Number One in adult listeners and, in some instances, to Number One across the board. Likewise, the success of Country music and Country performers on television is no longer open to debate. It's the real thing!

Just as radio and television soap operas, which deal in real situations, have survived all the critics, so Country music has survived and will continue to gain popularity because it is in touch with reality . . . it is now, more than ever, the music of the people.

The prime contributing factor in all of these success stories is reality. As more and more of the audience is exposed to Country product, the fact that Country music represents life as it is (love, marriage, divorce, drinking, death, prison are all part of life and the "stuff" from which Country songs are made), will make more and more converts and, consequently, more and more record buyers. And that means just one thing for all of us . . . more dollars, more profits, a more successful business.

In order to take advantage of the potential from the beginning of this small revolution, you must be willing to take a chance just as the Cincinnati distributor did. He had a hazy of knowing whether he could sell Country singles, but he took the chance and it paid off. There's an untapped gold mine in the real music and it's up to you to dig and find it and bank it.

So come on over to the real thing! Country music is, to use a phrase popular in that "other" area of music, where it's at! It's a now happening because it's the real thing!



**THE PERFECTIONISTS** . . . Kitty Wells at a recording session in Bradley's Barns with Owen Bradley, Director of Country A&R for Decca.

# WILBURN BROTHERS



LAND  
OF THE  
COUNTRY  
GIANTS



**DL 75214**

Available on 8-Track Cartridge and Cassette Tape

*Current Single:*  
**(Sing Your Heart Out) COUNTRY BOY**  
**32683**

aso t  
ising  
ducts  
nuff,  
medi-  
uti-  
per-  
sified  
inks,  
oning  
ns of  
  
med  
litan  
y of  
busi-  
untry  
esult,  
h in  
num-  
some  
the  
oun-  
rs on  
bate.  
  
soap  
ions.  
oun-  
con-  
it is  
now  
the  
  
n al  
7. As  
s ex  
that  
it is  
king  
and  
ongs  
more  
and  
ears  
more  
cess-  
  
i the  
this  
illing  
nnati  
y of  
oun-  
e and  
gold  
up to  
  
hink!  
pop-  
music.  
ening  
  
sion in  
  
4, 1970

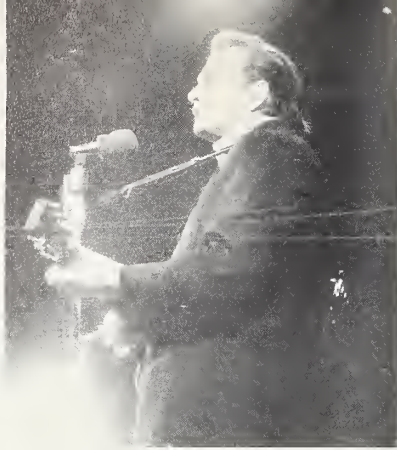

# The Big Three



## Most Programmed Record

- 1 A BOY NAMED SUE — Johnny Cash — Columbia
- 2 OKIE FROM MUSKOGEE — Merle Haggard — Capitol
- 3 ALL I HAVE TO OFFER YOU IS ME — Charley Pride — RCA

## Most Programmed Album

- 1 JOHNNY CASH AT SAN QUENTIN — J. Cash — Columbia
- 2 BEST OF CHARLEY PRIDE — C. Pride — RCA
- 3 TAMMY WYNETTE'S GREATEST HITS — T. Wynette — Epic

## Most Programmed Male Vocalist

- TIE: 1 JOHNNY CASH — Columbia
- 2 MERLE HAGGARD — Capitol
  - 3 CHARLEY PRIDE — RCA
  - 3 NEIL DIAMOND — Uni

## Most Promising Up & Coming Male Vocalist

- 1 ANTHONY ARMSTRONG JONES — Chart
- 2 BUDDY ALAN — Capitol
- 3 TOMMY CASH — Epic

## Most Programmed Female Vocalist

- 1 TAMMY WYNETTE — Epic
- 2 LORETTA LYNN — Decca
- 3 LYNN ANDERSON — (Columbia/Chart)

## Most Promising Up & Coming Female Vocalist

- 1 CONNIE EATON — Chart
- 2 LAWANDA LINDSEY — Chart
- 3 SUSAN RAYE — Capitol

## Most Programmed Vocal Groups

- 1 PORTER WAGONER & DOLLY PARTON — RCA
- 2 TOMPALL & GLASER BROS. — MGM
- 3 HAGERS — Capitol

## Most Promising Up & Coming Vocal Groups

- 1 HAGERS — Capitol
- 2 JACK BLANCHARD & MISTY MORGAN — Wayside
- 3 COMPTON BROS. — Dot

## Most Programmed Bands & Orchestras

- 1 DANNY DAVIS & NASHVILLE BRASS — RCA
- 2 BUCK OWENS' BUCKAROOS — Capitol
- 3 MERLE HAGGARD'S STRANGERS — Capitol

## Most Promising Up & Coming Bands & Orchestras

- 1 DANNY DAVIS & NASHVILLE BRASS — RCA
- 2 TENNESSEE GUITARS — SSS International
- 3 HARLOW WILCOX & OKIES — Plantation

## Most Programmed Instrumentalists

- 1 CHET ATKINS — RCA
- 2 FLOYD CRAMER — RCA
- 3 DANNY DAVIS & NASHVILLE BRASS — RCA

## Most Promising Up & Coming Instrumentalist

- 1 JERRY SMITH — Decca
- 2 HARLOW WILCOX & OKIES — Plantation
- 3 LLOYD GREEN — Chart

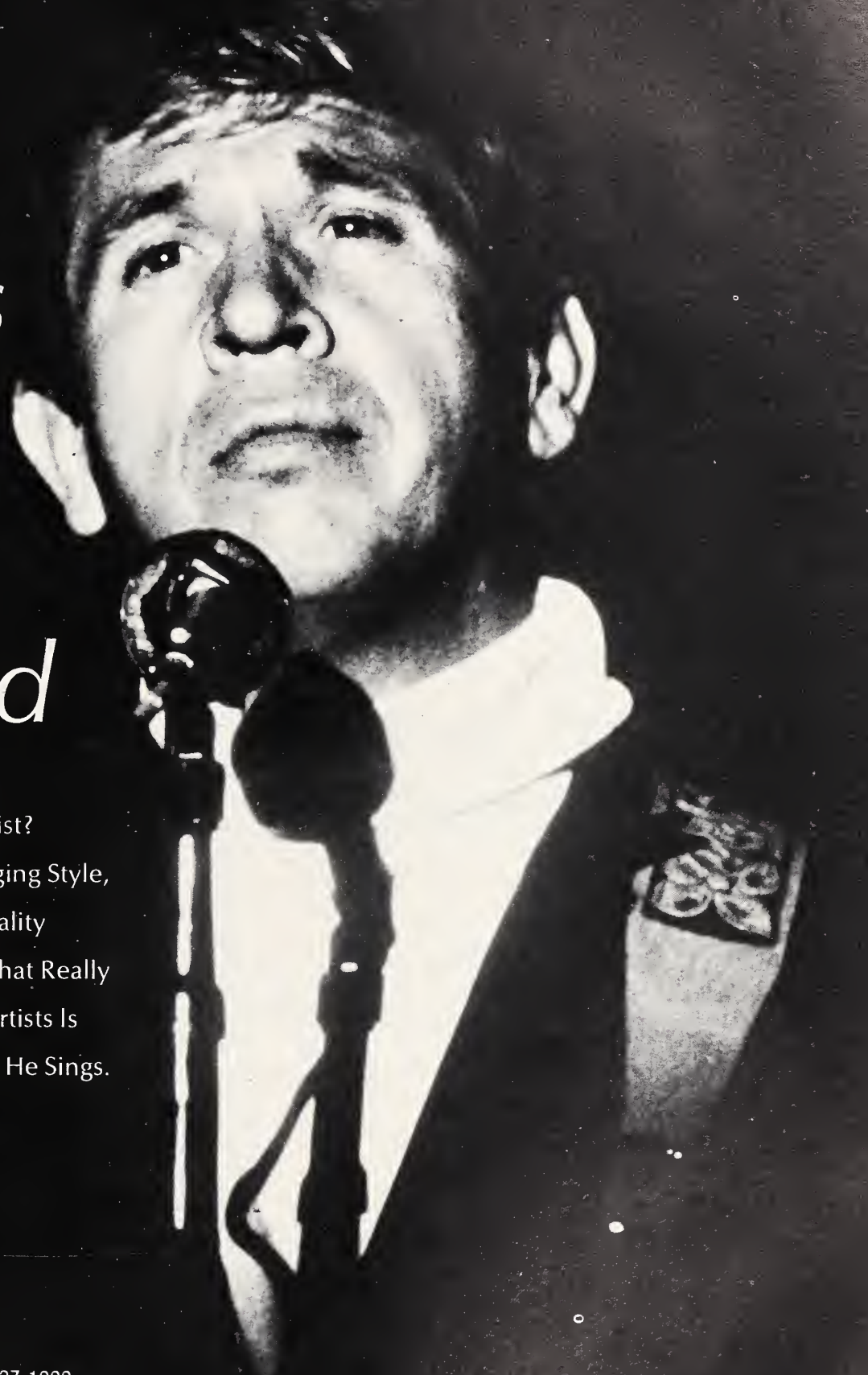

*Buck  
Owens  
Lives  
Every  
Word*

Why Is BUCK OWENS Such A Great Artist?

Of Course, His Unique Singing Style,  
His Showmanship And His Stage Personality

Are All Part Of The Answer. But What Really  
Sets BUCK OWENS Apart From Other Artists Is

His Infinite Talent To Live Every Word He Sings.



Personal Manager: Jack McFadden

403 Chester Ave. Bakersfield, Calif. (805) 327-1000

THANKS TO  
EVERYONE  
FOR MAKING  
THIS YEAR (SO FAR)  
THE GREATEST IN  
WAYSIDE'S HISTORY

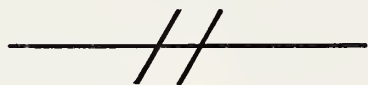

from all of us  
at Wayside Records

JIMMY SNYDER  
DARRELL McCALL  
JACK BLANCHARD

&

MISTY MORGAN  
HAL WILLIS  
PROFESSOR TERRELL JONES

AND A SPECIAL THANKS FROM  
LITTLE RICHIE JOHNSON  
(NATIONAL PROMOTIONS)

Distributed By: MERCURY/SMASH

## CASH BOX 1970 DISC JOCKEY POLL COUNTRY

### MOST PROGRAMMED COUNTRY SINGLES

- 1 A BOY NAMED SUE — Johnny Cash — Columbia
- 2 OKIE FROM MUSKOGEE — Merle Haggard — Capitol
- 3 ALL I HAVE TO OFFER YOU IS ME — Charley Pride — RCA
- 4 Tennessee Birdwalk — Jack Blanchard & Misty Morgan — Wayside
- 5 Tall Dark Stranger — Buck Owens — Capitol
- 6 The Ways To Love A Man — Tammy Wynette — Epic
- 7 (I'm So) Afraid Of Losing You Again — Charley Pride — RCA
- 8 Groovy Grubworm — JHarlow Wilcox & Okies — Plantation
- 9 One Minute Past Eternity — Jerry Lee Lewis — Sun
- 10 The Fightin' Side Of Me — Merle Haggard — Capitol
- 11 Stand By Your Man — Tammy Wynette — Epic
- 12 Welfare Cadillac — Guy Drake — Royal American
- 13 Fancy — Bobbie Gentry — Capitol
- 14 A Week In A Country Jail — Tom T. Hall — Mercury
- 15 Is Anybody Goin' To San Antone — Charley Pride — RCA
- 16 Try A Little Kindness — Glen Campbell — Capitol
- 17 Baby, Baby — David Houston — Epic

### MOST PROGRAMMED COUNTRY ALBUMS

- 1 JOHNNY CASH AT SAN QUENTIN — J. Cash — Columbia
- 2 BEST OF CHARLEY PRIDE — C. Pride — RCA
- 3 TAMMY WYNETTE'S GREATEST HITS — T. Wynette — Epic
- 4 Okie From Muskogee — Merle Haggard — Capitol
- 5 Just Plain Charley — Charley Pride
- 6 Glen Campbell "Live" — G. Campbell — Capitol
- 7 Movin' On — Danny Davis & Nashville Brass — RCA
- 8 It's Just A Matter Of Time — Sonny James — Capitol
- 9 Porter Wayne & Dolly Rebecca — Porter Wagoner & Dolly Parton — RCA
- 10 Hello, I'm Johnny Cash — J. Cash — Columbia
- 11 Best Of Merle Haggard — M. Haggard — Capitol
- 12 Hank Williams, Jr., Live At Cobo Hall — H. W., Jr. — MGM
- 13 Best Of Buck Owens, Vol. 2 — Buck Owens — Capitol
- 14 Easy Way — Claude Gray — Decca
- 15 Big In Vegas — Buck Owens — Capitol
- 16 Same Train, Different Time — Merle Haggard — Capitol
- 17 Tall Dark Stranger — Buck Owens
- 18 Loretta Lynn Sings "Wings Upon Your Horns" — L. Lynn — Decca
- 19 Johnny Cash At Folsom Prison — Johnny Cash — Columbia
- 20 Bill Anderson Story — Bill Anderson — Decca

### MOST PROGRAMMED VOCAL GROUPS

- 1 PORTER WAGONER & DOLLY PARTON — RCA
- 2 TOMPALL & GLASER BROS. — MGM
- 3 HAGERS — Capitol
- 4 Jack Blanchard & Misty Morgan — Wayside
- 5 Johnny & Jonie Mosby — Capitol
- 6 Buckaroos — Capitol
- 7 Jim & Jesse — Epic
- 8 Wilburn Bros. — Decca
- 9 Stonemans — RCA
- 10 Buck Owens & Susan Raye — Capitol
- 11 Bill Anderson & Jan Howard — Decca
- 12 Nat Stuckey & Connie Smith — RCA
- 13 Osborne Bros. — Decca
- 14 Kimberleys — RCA
- 15 Chaparral Bros. — Capitol
- 16 Statler Bros. — Columbia
- 17 Jack Greene & Jeannie Seely — Decca
- 18 Don Gibson & Dottie West — RCA
- 19 Babby Bare & Skeeter Davis — RCA

#1#1#1#1#1 and now...

**Capitol introduces  
The Southern Gentleman's biggest**



**'DON'T  
KEEP ME  
HANGIN'  
ON'**

Exclusively On



Capitol 2834

Manager: Bob Neal  
817 18th Ave. So.  
Nashville, Tenn. 37203  
(615) 327-2373

# To NASHVILLE with Love

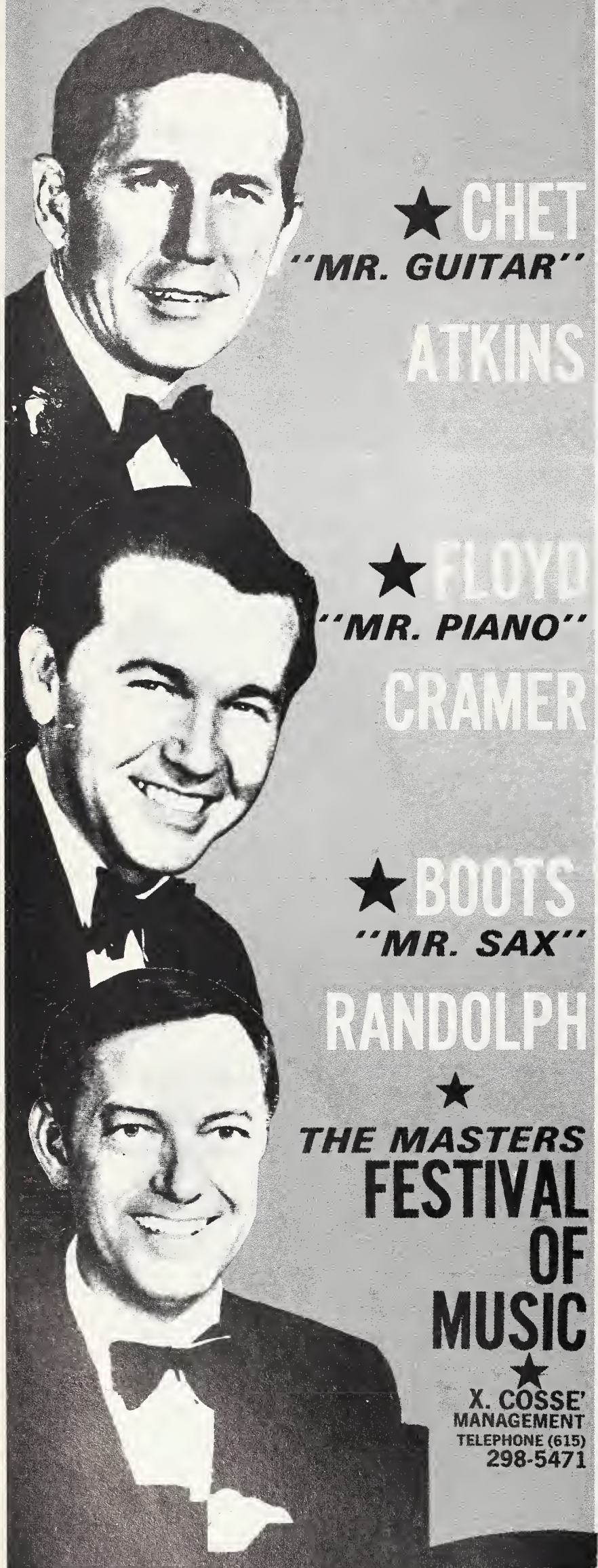

★ **CHET**  
 "MR. GUITAR"  
**ATKINS**

★ **FLOYD**  
 "MR. PIANO"  
**CRAMER**

★ **BOOTS**  
 "MR. SAX"  
**RANDOLPH**  
 ★  
**THE MASTERS**  
**FESTIVAL**  
**OF**  
**MUSIC**

★  
**X. COSSE'**  
**MANAGEMENT**  
 TELEPHONE (615)  
 298-5471

1516 SIXTEENTH AVENUE, SOUTH ★ NASHVILLE, TENNESSEE 37212

## MOST PROGRAMMED MALE VOCALISTS

- 1 JOHNNY CASH — Columbia
- 2 MERLE HAGGARD — Capitol
- 3 CHARLEY PRIDE — RCA
- 4 Buck Owens — Capitol
- 5 Glen Campbell — Capitol
- 6 Jerry Lee Lewis — Smash-Sun
- 7 Sonny James — Capitol
- 8 David Houston — Epic
- 9 Conway Twitty — Decca
- 10 Bill Anderson — Decca
- 11 Jack Greene — Decca
- 12 George Jones — Musicor
- 13 Marty Robbins — Columbia
- 14 Nat Stuckey — RCA
- 15 Elvis Presley — RCA
- 16 Eddy Arnold — RCA
- 17 Glenn Barber — Hickory
- 18 Mel Tillis — Kapp (now MGM)
- 19 Del Reeves — United Artists
- 20 Willie Nelson — RCA
- 21 Roy Clark — Dot

## MOST PROGRAMMED FEMALE VOCALISTS

- 1 TAMMY WYNETTE — Epic
- 2 LORETTA LYNN — Decca
- 3 LYNN ANDERSON — (Columbia/Chart)
- 4 Connie Smith — RCA
- 5 Dolly Parton — RCA
- 6 Jeannie C. Riley — Plantation
- 7 Dottie West — RCA
- 8 Jean Shepard — Capitol
- 9 Bobbie Gentry — Capitol
- 10 Wanda Jackson — Capitol
- 11 Skeeter Davis — RCA
- 12 Liz Anderson — RCA
- 13 Susan Raye — Capitol
- 14 Kitty Wells — Decca

## Most Promising Up & Coming Male Vocalists

- 1 ANTHONY ARMSTRONG JONES — Chart
- 2 BUDDY ALAN — Capitol
- 3 TOMMY CASH — Epic
- 4 Freddy Weller — Columbia
- 5 Tom T. Hall — Mercury
- 6 David Rogers — Columbia
- 7 Ron Lowry — Republic
- 8 John Wesley Ryles I — Columbia
- 9 Kenny Vernon — Chart
- 10 Mac Davis — Columbia
- 11 Gene Price — Capitol
- 12 David Frizell — Columbia
- 13 Jimmy Snyder — Wayside
- 14 Jerry Reed — RCA
- 15 Don Rich — Capitol
- 16 Doyle Holly — Capitol
- 17 Ira Allen — Capitol
- 18 Lawrence Reynolds — Warner Bros.
- 19 Raymond A. Smith — Sugar Hill

## Most Promising Up & Coming Female Vocalists

- 1 CONNIE EATON — Chart
- 2 LAWANDA LINDSEY — Chart
- 3 SUSAN RAYE — Capitol
- 4 Barbara Mandrell — Columbia
- 5 Peggy Little — Dot
- 6 Peggy Sue — Decca
- 7 Linda K. Lance — Royal American
- 8 Barbara Fairchild — Columbia
- 9 Leona Williams — Hickory
- 10 Arlene Harden — Columbia
- 11 Lynn Anderson — Chart (now Columbia)
- 12 Billie Jo Spears — Capitol
- 13 Linda Martell — Plantation
- 14 Jessi Colter — RCA
- 15 Diana Trask — Dot
- 16 Brenda Byers — MTA
- 17 Margaret Brixey — Decca



*Thank you  
for voting us  
number one  
The Hagers*



## Most Programmed Bands & Orchestras

- 1 DANNY DAVIS & NASHVILLE BRASS — RCA
- 2 BUCK OWENS' BUCKAROOS — Capitol
- 3 MERLE HAGGARD'S STRANGERS — Capitol
- 4 Hank Thompson's Brazos Valley Boys — Dot
- 5 Nashville Strings — Columbia
- 6 Ernest Tubb's Troubadors — Decca
- 7 Tennessee Guitars — SSS International
- 8 Bill Anderson's Po' Boys — Decca

## Most Programmed Instrumentalists

- 1 CHET ATKINS — RCA
- 2 FLOYD CRAMER — RCA
- 3 DANNY DAVIS & NASHVILLE BRASS — RCA
- 4 Buckaroos — Capitol
- 5 Lloyd Green — Chart
- 6 Roy Clark — Dot
- 7 Pete Drake — Stop
- 8 Harlow Wilcox & Okies — Plantation
- 9 Merle Haggard's Strangers — Capitol
- 10 Jerry Smith — Decca
- 11 Jerry Reed — RCA
- 12 Boots Randolph — Monument
- 13 Ace Cannon — Hi

## Up & Coming Bands & Orchestras

- 1 DANNY DAVIS & NASHVILLE BRASS — RCA
- 2 TENNESSEE GUITARS — SSS International
- 3 HARLOW WILCOX & OKIES — Plantation

## Up & Coming Instrumentalists

- 1 JERRY SMITH — Decca
- 2 HARLOW WILCOX & OKIES — Plantation
- 3 LLOYD GREEN — Chart
- 4 Jerry Reed — RCA
- 5 Merle Haggard's Strangers — Capitol



Thanks Jocks For Helping Me

Build My Career .....

"LIVE YOUR LIFE OUT LOUD"

"THE TRUE AND LASTING KIND"

"YESTERDAY'S LETTERS"

"RAINBOW GIRL"

"YOU AND ME AGAINST THE WORLD"

**BOBBY LORD ON DECCA RECORDS**

## Most Promising Up & Coming Vocal Group

- 1 HAGERS — Capitol
- 2 JACK BLANCHARD & MISTY MORGAN — Wayside
- 3 COMPTON BROS. — Dot
- 4 Buck Owens & Susan Raye — Capitol
- 5 Kimberlys — RCA
- 6 Nat Stuckey & Connie Smith — RCA
- 7 Stonemans — RCA
- 8 Harper Valley P.T.A. — Plantation
- 9 Lawanda Lindsey & Kenny Vernon — Chart
- 10 Kendalls — Stop
- 11 Connie Eaton & Dave Peel — Chart
- 12 Johnny & Jonie Mosby — Capitol

## PAST POLL WINNERS COUNTRY

### Most Programmed Single

- 1960—El Paso—Marty Robbins—Columbia  
He'll Have To Go—Jim Reeves—RCA (Tie)
- 1961—Wings Of A Dove—Ferlin Husky—Capitol
- 1962—Big Bad John—Jimmy Dean—Columbia
- 1963—Still—Bill Anderson—Decca
- 1964—Love's Gonna Live Here—Buck Owens—Capitol
- 1965—I've Got A Tiger By The Tail—Buck Owens—Capitol
- 1966—Waitin' In Your Welfare Line—Buck Owens—Capitol
- 1967—Almost Persuaded—David Houston—Epic
- 1968—I Don't Want To Play House—Tammy Wynette—Epic
- 1969—Harper Valley PTA—Jeannie C. Riley—Plantation
- 1970—A Boy Named Sue—Johnny Cash—Columbia

### Most Programmed Album

- 1961—Gunfighter Ballads—Marty Robbins—Columbia
- 1962—Girls, Guitars & Gibson—Don Gibson—RCA
- 1963—New Favorites of George Jones—United Artists
- 1964—Buck Owens on The Bandstand—Capitol
- 1965—I Don't Care—Buck Owens—Capitol
- 1966—Best of Jim Reeves Vol. II—RCA
- 1967—You Ain't Woman Enough—Loretta Lynn—Decca
- 1968—Best of Eddy Arnold—RCA
- 1969—Wichita Lineman—Glen Campbell—Capitol
- 1970—Johnny Cash At San Quentin—Columbia

### Most Programmed Male Vocalist

- 1960—Jim Reeves—RCA
- 1961—Marty Robbins—Columbia
- 1962—George Jones—United Artists
- 1963—George Jones—United Artists
- 1964—Buck Owens—Capitol
- 1965—Buck Owens—Capitol
- 1966—Buck Owens—Capitol
- 1967—Buck Owens—Capitol
- 1968—Buck Owens—Capitol
- 1969—Glen Campbell—Capitol
- 1970—Johnny Cash—Columbia

### Most Programmed Female Vocalist

- 1960—Kitty Wells—Decca
- 1961—Kitty Wells—Decca
- 1962—Kitty Wells—Decca/Patsy Cline—Decca (Tie)
- 1963—Patsy Cline—Decca
- 1964—Loretta Lynn—Decca
- 1965—Loretta Lynn—Decca
- 1966—Loretta Lynn—Decca/Connie Smith—RCA (Tie)
- 1967—Loretta Lynn—Decca
- 1968—Loretta Lynn—Decca/Tammy Wynette—Epic (Tie)
- 1969—Tammy Wynette—Epic
- 1970—Tammy Wynette—Epic

### Most Programmed Vocal Group

- 1960—The Browns—RCA
- 1961—Wilburn Bros.—Decca
- 1962—Wilburn Bros.—Decca
- 1963—Lester Flatt & Earl Scruggs—Columbia
- 1964—Lester Flatt & Earl Scruggs—Columbia
- 1965—The Browns—RCA
- 1966—Wilburn Bros.—Decca
- 1967—The Browns—RCA
- 1968—Wilburn Bros.—Decca
- 1969—Tompall & The Glaser Bros.—MGM
- 1970—Porter Wagoner & Dolly Parton—RCA



**A dash of this, a pinch of that.  
Cut to suit your taste.**

**You get fine country music  
on the Paramount and Dot labels.**



**Paramount Records  
a division of Famous Music Corp.  
A Gulf+Western Company**



*Sesac  
Publishers*

SCHUBERTH, EDWARD, & COMPANY, 39 West 60th St., New York, N.Y. 10023

SEBREN, GEORGE W., MUSIC COMPANY, (See Tennessee Music & Printing Co.)

SELECT MUSIC COMPANY, (See National Music Company, Inc.)

SELMER, H. & A., INC., (See Schmitt, Hall & McCreary Co.)

SEYFARTH, G., (See "PWP")

SHAW, EDWARD L., 209 N. Lauderdale, Memphis, Tennessee 38105

SHONO MUSIC, 2513 Vine Street, Chattanooga, Tenn.

SHOWALTER, A. J., COMPANY, THE, (See Tennessee Music & Printing Co.)

SHOWALTER, G. H. P., (See Firm Foundation Publishing House)

SINGSPARATION, (See Singspiration Inc.)

SINGSPARATION, INC., 4145 Kalamazoo, S.E., Grand Rapid, Michigan 49508

SIoux WAY MUSIC, c/o Abe Turchin, P. O. Box 2014, Northside, Sioux City, Iowa 51104

SISTER MUSIC COMPANY, 10 Maple St., Brooklyn, N. Y. 11225

SIZZLE MUSIC CORPORATION, 318 West 48th St., New York, N. Y. 10036, (Only compositions as per listed issued)

SLATER, WILL W., (See Slater Company, The)

SLATER COMPANY, THE, 3520 Boulder Drive, Dallas, Texas 75233, including: SLATER, WILL W.

SLAUGHTER, HENRY T., P. O. Box 8073, Nashville, Tenn. 37207

SLIP & SLIDE MUSIC COMPANY, 120 Belair Drive, Dobbs Ferry, N. Y. 10522

SMITH, ALFRED B., (See Singspiration, Inc.)

SMITH, BOBBY, PUBLISHING COMPANY, 2605 Elizabeth, Muskogee, Oklahoma 74401

SMITH, M. LYNWOOD, PUBLICATIONS, Wesson, Miss., 39191

SMOKEY MUSIC, 728 16th Avenue, South, Nashville, Tennessee 37203

SOUTHERN, HAL, (See Golden Valley Music)

SOUTHERN MUSIC PLATE COMPANY, (See Henson, J. M., Music Company)

SPEER, BEN, MUSIC, P. O. Box 9201, Nashville, Tenn. 37204

SPIRE EDITIONS, (See World Library Publications, Inc.)

STAMPS QUARTET MUSIC COMPANY, INC., P. O. Box 6992, Nashville, Tennessee 37215, including: PARRIS MUSIC COMPANY, PARRIS, O. A.

STANDARD MUSIC COMPANY, (See National Music Company, Inc.)

STANDARD SONGS, (See National Music Company, Inc.)

STANPHILL, IRA, 4308 Kirkland Drive, Fort Worth, Texas 76109

STAR CITY MUSIC, (Div. of Goldmont Music Inc.), 726 16th Avenue South, Nashville, Tennessee 37203

STAR TOWN, 420 E. Main Street, Chattanooga, Tennessee 37408

STIRLING MUSIC PUBLISHING COMPANY, 1650 Broadway, New York, N. Y. 10019, including: AV-ALON MUSIC PUBLISHING COMPANY

STOKER MUSIC COMPANY, INC., 720 Benton Smith Rd., Nashville, Tenn. 37215, including: DANIEL, JOHN

STONEHENGE MUSIC INC., 110 Belle Meade Blvd., Nashville, Tenn. 37205

SUMAR MUSIC INC., 912 17th Avenue, South, Nashville, Tennessee 37215

SUMNER, DONALD HOWARD, 912 17th Avenue, South, Nashville, Tennessee 37215

SUMNER, J. D., P. O. Box 6992, Nashville, Tennessee, 37215

SUNDAY SCHOOL BOARD OF THE SOUTHERN BAPTIST CONVENTION, THE, (See Broadman Press)

SWORD & SHIELD MUSIC COMPANY, P. O. Box 50, Nashville, Tenn. 37202

**T**

TALENT HOUSE MUSIC, 1136 Sunnyside Drive, Nashville, Tenn. 37216

TAV-RINA, EDITION, (See "IPA")

TEMPO MUSIC SERVICE, (See Lillenas Publishing Company)

TENNESSEE MUSIC & PRINTING COMPANY, Cleveland, Tenn. 37311

THOMPSON MUSIC COMPANY, Route 5, Box 137B, Lake Charles, Louisiana 70601

TOP MUSIC PUBLISHERS, INC., 74 Riverside Drive, New York, N. Y. 10024, including: KANNER MUSIC PUBLISHING COMPANY, NETWORK MUSIC PUBLISHERS

TOWARZYSTWO WYDAWNICZE MUZYKI POLSKIEJ, (See "PWP")

TRAFICANTE MUSIC PUBLISHING COMPANY, (See Schmidt, A. P. Co.)

TRIO MUSIC COMPANY, (See Firm Foundation Publishing House)

**U**

UNIVERSUM, (See "PWP")

**V**

VAUGHAN, JAMES D., MUSIC PUBLISHER, (See Church of God Publishing House, The)

VELVA MUSIC, INC., c/o Joseph J. Drexler, 60 East 42nd Street, New York, New York 10017

VICCAS MUSIC PUBLISHING COMPANY, (See Deiro, Pietro, Publications)

VITAK-ELSNIC COMPANY, 4815 South Ashland Ave., Chicago, Ill. 60609, including: GEORGE & VITAK MUSIC COMPANY, KRACHTUS, JOHN, COMPANY

**W**

WALLS, W. M., (See Revival Music Company)

WANDERING ACRES MUSIC INC., 1314 Pine Street, Nashville, Tennessee 37203

WARDE, HARRY, (See Schmidt, A. P., Co.)

WARNER, F. EUGENE, (See Schmidt, A. P., Co.)

WARTBURG PRESS, THE, (See Augsburg Publishing House)

WEANER-LEVANT PUBLICATIONS, (See Mercury Music Music)

WEANER, MAXWELL, (See Mercury Music)

WESTERN ACCORDION MUSIC COMPANY, (See Schmidt, A. P., Co.)

WESTERN SWING MUSIC, Route 5, Box 327, Rogers, Arkansas 72756

WHEELWRIGHT, LORIN F., (See Pioneer Music Press)

WHITE CHAPEL PRESS, P. O. Box 4187, South Daytona, Florida 32021

WIEHLER, ZYGMUNT, (See "PWP")

WILLIS MUSIC COMPANY, THE, 440 Main Street, Cincinnati, Ohio 45201

WILLIS PUBLICATIONS, INC., 601 Perrine St., Box 72, Farmington, Missouri 63640

WINDSOR MUSIC COMPANY, (See National Music Company, Inc.)

WINSETT, R. E., MUSIC COMPANY, 128 East 2nd Avenue, P. O. Box 327, Dayton, Tenn. 37321

WINTERNITZ, CHANAN, (See "IPA")

WJB MUSIC COMPANY, 250 Tyrone Ave., Teaneck, N. J. 07666

"WJR", (See "PWP")

WOHL, JEHUDA, (See "IPA")

WOLFPACK MUSIC CORP., 359 North Canon Drive, Beverly Hills, Calif. 90210, (Only compositions as per list issued)

WOODLAND FOREST MUSIC INC., 812 16th Avenue, South, Nashville, Tennessee 37203

WORLD LIBRARY OF SACRED MUSIC, (See World Library Publications, Inc.)

WORLD LIBRARY PUBLICATIONS, INC., 2145 Central Parkway, Cincinnati, Ohio 45214, including: SPIRE EDITIONS, WORLD LIBRARY OF SACRED MUSIC

WYDAWNICTWO MUZYCZNE "SYNKOPA", (See "PWP")

WYNERT, JOHNNY, (See "IPA")

**X**

XIV MUSIC CO., INC., 723 Seventh Avenue, New York, N. Y. 10019

**Z**

"ZAIKS," STOWARZYSZENIE AUTOROW, (Society of Authors) (See "PWP")

ZAK, CZESLAW, (See "PWP")

ZELLNER, HARRY, 210 West 101st Street, New York, N. Y. 10025, including: ISLAND MUSIC

**MEXICO**

**70**

P.O. Box 11-620  
© México 11, D.F.,  
MEXICO

THE FASTEST GROWING RECORDS AND  
PUBLISHING COMPANIES



RECORD COMPANY  
DISCOS TIZOC, S.A.



PUBLISHING COMPANY  
EDITORIAL TEOCALI, S.A.

R&B: The 'Catalog' Sound (Ed) . . . Stax/Volt: Indie  
Again . . . Elektra's Harvey On The Label's 'Age Of  
Maturity' ... Col Promo: Communication & Credibility

VIDCA Formed:  
Int'l Video  
Cartridge Assn

# Cash Box

July 4, 1976  
Part 2 of 2 Parts

... Scepter's Susan Of 'Sesame St.' LP ... Al-  
ternate Media Report ... Canada Content Rul-  
ing Brings Label, Pub Aid To Broadcasters

\$1.00



BLOOD, SWEAT & TEARS: COLUMBIA'S BAND OF GOLD

INT'L SECTION BEGINS ON PAGE 45





A Mac Davis song is just that way. Lyrics become images. Songs become paintings. Like his new single, "I'll Paint You A Song." The single Bill Gavin said "has to rank as one of the finest love songs ever. Beautifully sung by the composer."

It's a follow-up to "Whoever Finds This, I Love You."

He's written lots of hit singles: "In The Ghetto," "Don't Cry Daddy," "Friend, Lover, Woman, Wife," "Daddy's Little Man" and "Somethin's Burnin'."

So when Mac writes a single, it's easy to get the picture.



Mac Davis.  
 "I'll Paint You  
 A Song." <sup>4-45192</sup>  
 On Columbia  
 Records 

**GEORGE ALBERT**  
*President and Publisher*

**MARTY OSTROW**  
*Vice President*

**IRV LICHMAN**  
*Editor in Chief*

**EDITORIAL**

MARY GOODMAN  
Assoc. Editor  
ALLAN RINDE  
West Coast Editor  
JOHN KLEIN  
ED KELLEHER  
FRED HOLMAN  
ERIC VAN LUSTBADER

**EDITORIAL ASSISTANTS**

MIKE MARTUCCI  
ANTHONY LANZETTA

**ADVERTISING**

**BERNIE BLAKE**  
*Director of Advertising*

**ACCOUNT EXECUTIVES**

STAN SOIFER, New York  
HARVEY GELLER, Hollywood  
WOODY HARDING  
*Art Director*

**COIN MACHINE & VENDING**  
**ED ADLUM**

*General Manager*

CAMILLE COMPASIO, Chicago  
LISSA MORROW, Hollywood

**CIRCULATION**

THERESA TORTOSA, Mgr.

**HOLLYWOOD**

HARVEY GELLER  
6430 Sunset Blvd., Hollywood, Calif. 90028  
Phone: (213) 465-2129

**NASHVILLE**

JUANITA JONES  
806 16th Ave. South, Nashville, Tenn. 37203  
Phone: (615) 244-2898

**CHICAGO**

CAMILLE COMPASIO  
29 E. Madison St., Chicago, Ill. Phone: (312) FI 6-7272

**INTERNATIONAL DIRECTOR**

**CARLO NISTRÌ**

3 Cork Street, London W1 Tele 01-7342374.

**ENGLAND**

DORRIS LAND  
3 Cork Street  
London W1  
Tel. 01-7342374

**GERMANY**

CHRISTIAN TOERSLEFF  
2 Hamburg 56  
Leuchtturmeg 30  
Tel: 34-91-94-86

**BRAZIL**

PEDRO FRAZAO  
DE VASCONCELOS  
Rua Frei Caneca, 11, Apt. 13  
Sao Paulo, S.P., Brazil  
Tel: 257 15 58

**ARGENTINA**

MIGUEL SMIRNOFF  
Belgrano 3252, Piso 4 "B"  
Buenos Aires, Argentina  
Tel: 89-6796

**CANADA**

WALT GREALIS  
RPM  
1560 Bayview Ave.  
Toronto 17, Ontario  
Tel: (416) 89-2166

**FRANCE**

FRANC G. LIPSIC  
32 Rue Du Moulin Joly  
Paris XI  
Tel. 023-90-06

**SPAIN**

JOAQUIN MERINO  
Presidente Carmona, 11  
Madrid 20, Spain  
Tel. 270-2915

**ITALY**

BRUNO POZZA  
5, Corso Europa  
Milan  
Tel: 704691

**HOLLAND**

PAUL ACKET  
Theresiastraat 59-63  
The Hague  
Tel: 837700

**BELGIUM**

ETIENNE SMET  
Hugo Verrieststraat 87  
Sint-Niklaas (w.s)  
Tel: (03) 76.48.80

**AUSTRALIA**

PETER SMITH  
40 Winters Way  
Doncaster 3108  
Victoria, Australia

**MEXICO**

SALVADOR ARREGUIN  
ANTONIO SENS  
Tiber 100 — 7 y 8 Pisos  
Mexico 5, D.F.  
Tel: 525-39-52 11-62-96

**JAPAN**

Adv. Mgr.  
SHOICHI KUSANO  
Editorial Mgr.  
MORIHIRO NAGATA  
466 Higfashi-Olzumi  
Neirimaku  
Tokyo

## R&B:

# The 'Catalog' Sound

Human nature, being what it is, tends to relegate to indifference long-running success. Nowhere is this more true in the recording business than in the area of R&B sounds. Somehow, new sound fancies seem to cast a shadow over the day-to-day sales momentum of the R&B sound. R&B music is, in a sense, a catalog sound, affording labels involved in this field steady success, not just in one section of the marketplace, but in the broad spectrum of pop music buyers as well. Each week, the Top 100 lists a number of more or less "pure-styled" R&B sounds that, obviously, are winning over a wide cross-section of the record/tape buyer.

Interesting at this stage, the very soul of R&B music, the sound of gospel music, is adding an even stronger dimension to the continued appeal of this often understated music. Since gospel music itself has often stressed, with great beauty and poignancy, the burdens of a people and their faith in a better future, a gospel feel pervades a number of recent and current hits that, like gospel, state without rancor or remorse a message of timelessness. There's "Bridge Over Troubled Water" by Simon & Garfunkel, "Let It Be" by the Beatles, "Lay Down" by

Melanie & the Edwin Hawkins Singers, "Are You Ready" by Pacific Gas & Electric, "United We Stand" by Brotherhood of Man, "Everything Is Beautiful" by Ray Stevens, whose gospel approach is accented by a church choir-like chorus.

Thus, R&B music, making social commentary or not (though lately there's been an abundance of the former), and the gospel feel are combining to indicate the timelessness of their own appeal. Perhaps the present gospel touch which some years ago made a vain try at a "new" trend in music, is not the wave of the pop future, it still serves to highlight the R&B-gospel approach as one that offers the industry tried-and-true acceptance, that acceptance of which we sometimes take too much for granted.

As we noted at the start of this piece, human nature sends out to pasture, so to speak, some of the good things in life. Like Broadcast Music, Inc. (BMI), once pointed out with great drama in an ad series called "The Day Music Stopped," the world of music would certainly be shocked to find the sound of R&B no longer available. That would bring a lot of music to a grinding halt.

Rank	Song	Artist	Label	6/27	6/20
1	THE LOVE YOU SAVE	Jackson 5	Motown 1166	1	4
2	MAMA TOLD ME NOT TO COME	Three Dog Night	Dunhill 4239	5	10
3	BALL OF CONFUSION	Temptations	Gordy 7099	9	17
4	LAY DOWN (CANDLES IN THE RAIN)	Melanie & Edwin Hawkins Singers	Buddah 167	6	7
5	RIDE CAPTAIN RIDE	Blues Image	Atco 6746	8	9
6	HITCHIN' A RIDE	Vanity Fare	Page One 21029 (Dist: Bell)	4	6
7	GET READY	Rare Earth	Rare Earth 5012 (Dist: Motown)	2	7
8	LONG AND WINDING ROAD	Beatles	Apple 2832 (Dist: Capitol)	3	1
9	BAND OF GOLD	Freda Payne	Invictus 9075 (Dist: Capitol)	18	21
10	THE WONDER OF YOU	Elvis Presley	RCA 9835	11	15
11	WHICH WAY YOU GOIN' BILLY	Poppy	Family-London 129	7	2
12	MY BABY LOVES LOVIN'	White Plains	Deram 85058 (Dist: London)	10	11
13	UNITED WE STAND	Brotherhood of Man	Deram 85059 (Dist: London)	13	16
14	GIMME DAT DING	Pipkins	Capitol 2819	15	23
15	A SONG OF JOY	Miguel Rios	A&M 1193	20	38
16	O-O-H CHILD	Five Stairsteps	Buddah 165	22	28
17	LOVELAND	Charles Wright & Watts	103rd St. Band Warner Bros. 7365	17	19
18	CLOSE TO YOU	Carpenters	A&M 1183	56	70
19	QUESTION	Moody Blues	Threshold 67004 (Dist: London)	19	20
20	IT'S ALL IN THE GAME	4 Tops	Motown 1164	14	14
21	TEACH YOUR CHILDREN	Crosby, Stills, Nash & Young	Atlantic 2735	26	33
22	SUGAR SUGAR	Wilson Pickett	Atlantic 2722	16	18
23	SIGNED, SEALED, DELIVERED I'M YOURS	Stevie Wonder	Tamla 54196	58	79
24	OHIO	Crosby, Stills, Nash & Young	Atlantic 2740	55	76
25	ARE YOU READY?	Pacific Gas & Electric	Columbia 45158	30	40
26	CHECK OUT YOUR MIND	Impressions	Curton 1951 (Dist: Buddah)	29	35
27	MISSISSIPPI QUEEN	Mountain	Windfall 532 (Dist: Bell)	28	31
28	SAVE THE COUNTRY	Fifth Dimension	Bell 895	32	52
29	SILVER BIRD	Mark Lindsay	Columbia 45180	35	43
30	WESTBOUND #9	The Flaming Embers	Hot Wax 7003 (Dist: Buddah)	38	42
31	TIGHTER AND TIGHTER	Alive & Kicking	Roulette 7078	43	61
32	GO BACK	Crabby Appleton	Elektra 45687	34	36
33	THE LETTER	Joe Cocker	A&M 1174	12	5
34	CANNED HAM	Norman Greenbaum	Reprise 0919	37	45
35	LOVE ON A TWO WAY STREET	Moments	Stang 5012	24	22
36	SO MUCH LOVE	Faith, Hope & Charity	Maxwell 805 (Dist: Crewe)	39	41
37	HEY, MISTER SUN	Bobby Sherman	Metromedia 188	23	26
38	THE END OF THE ROAD	Marvin Gaye	Tamla 54195	41	50
39	MAKE IT WITH YOU	Bread	Elektra 45686	65	80
40	MISSISSIPPI	John Phillips	Dunhill 4236	46	54
41	I WANT TO TAKE YOU HIGHER	Sly & The Family Stone	Epic 10450	40	63
42	SPIRIT IN THE DARK	Aretha Franklin	Atlantic 2731	25	27
43	DAUGHTER OF DARKNESS	Tom Jones	Parrot 40048 (Dist: London)	27	12
44	STEAL AWAY	Johnnie Taylor	Stax 0068	53	59
45	TRYING TO MAKE A FOOL OF ME	Delfonics	Philly Groove 162 (Dist: Bell)	47	48
46	I JUST CAN'T HELP BELIEVING	B. J. Thomas	Scepter 12283	57	73
47	THAT SAME OLD FEELING	Pickettywitch	Janus 118	51	62
48	EVERYTHING IS BEAUTIFUL	Ray Stevens	Barnaby 72011 (Dist: Columbia)	21	8
49	SWEET FEELING	Candi Staton	Fame 1466 (Dist: Capitol)	44	46
50	UP AROUND THE BEND	Creedence Clearwater Revival	Fantasy 641	33	24
51	COME SATURDAY MORNING	Sandpipers	A&M 1185	31	13
52	MAKE ME SMILE	Chicago	Columbia 45127	42	29
53	MY MARIE	Engelbert Humperdinck	Parrot 40049 (Dist: London)	76	—
54	LAY A LITTLE LOVIN' ON ME	Robin McNamara	Steed 724 (Dist: Paramount)	78	90
55	MAYBE	Three Degrees	Roulette 7079	78	90
56	BOYS IN THE BAND	Boys In The Band	Spring 103 (Dist: Polydor)	61	64
57	SPILL THE WINE	Eric Burdon	War-MGM 14118	67	69
58	SHE CRIED	Lettermen	Capitol 2820	60	72
59	IF YOU LET ME MAKE LOVE TO YOU THEN WHY CAN'T I TOUCH YOU	Ronnie Dyson	Columbia 45110	72	91
60	PEARL	Tommy Roe	ABC 11266	70	82
61	QUE SERA SERA	Mary Hopkin	Apple 1823 (Dist: Capitol)	81	—
62	SUNSHINE	Archies	Kirshner 1009 (Dist: RCA)	73	—
63	SUPERMAN	Ides Of March	Warner Bros. 7403	80	—
64	I'LL BE RIGHT HERE	Tyrone Davis	Dakar 618 (Dist: Atlantic)	74	85
65	COME TO ME	Tommy James & Shondells	Roulette 7076	36	67
66	A LITTLE BIT OF SOAP	Paul Davis	Bang 576	71	74
67	DON'T IT MAKE YOU WANNA GO HOME	Brook Benton	Cotillion 44078 (Dist: ATL/Atco)	48	47
68	BABY HOLD ON	Grass Roots	Dunhill 4237	49	25
69	AIN'T THAT LOVIN' YOU	Luther Ingram	KoKo 2105	45	47
70	OVERTURE FROM TOMMY	Assembled Multitude	Atlantic 2737	79	81
71	GIVE A WOMAN LOVE	Bobbi Martin	U.A. 50687	82	—
72	TELL IT ALL BROTHERS	Kenny Rogers & First Edition	Reprise 0923	—	—
73	WHEN WE GET MARRIED	Intruders	Gamble 4004	88	100
74	THAT SAME OLD FEELING	The Fortunes	World Pacific 77937	59	60
75	NO ARMS CAN EVER HOLD YOU	Bobby Vinton	Epic 10629	—	—
76	PRIMROSE LANE	O. C. Smith	Columbia 45160	77	78
77	APARTMENT 21	Bobbie Gentry	Capitol 2849	—	—
78	DESTINY	Jose Feliciano	RCA 0358	83	—
79	EVERYTHING A MAN COULD EVER NEED	Glen Campbell	Capitol 1260	—	—
80	SUMMERTIME BLUES	The Who	Decca 32708	—	—
81	SLY, SLICK & THE WICKED	The Lost Generation	Brunswick 55436	92	—
82	HUMPHREY THE CAMEL	John Blanchard & Misty Morgan	Wayside 013 (Dist: Mercury)	89	—
83	SIXTY MINUTE MAN	Rufus Thomas	Stax 0071	—	—
84	I WANT TO TAKE YOU HIGHER	Ike & Tina Turner	Liberty 56177	66	68
85	GOOD MORNING FREEDOM	Daybreak	Uni 55234	86	92
86	GIMME SHELTER	Merry Clayton	Ode '70 66003 (Dist: A&M)	87	84
87	YOUR OWN BACK YARD	Dion	Warner Bros. 7401	—	—
88	COTTAGE CHEESE	Crow	Amaret 119	68	71
89	YELLOW RIVER	Christie	Epic 10626	—	—
90	CINNAMON GIRL	Neil Young	Reprise 0911	90	97
91	HELLO DARLIN'	Conway Twitty	Decca 32661	93	—
92	LET THE MUSIC TAKE YOUR MIND	Kool & The Gang	De-Lite 529	97	—
93	YOU'VE BEEN MY INSPIRATION	Main Ingredient	RCA 0340	96	—
94	BIG YELLOW TAXI	Neighborhood	Big Tree 102	—	—
95	STEALING IN THE NAME OF THE LORD	Paul Kelly	Happy Tiger 541	—	—
96	MELANIE MAKES ME SMILE	Tony Burrows	Bell 884	95	98
97	AFTER THE FEELING IS GONE	Lulu	Atco 6761	—	—
98	THIS BITTER EARTH	Satisfactions	Lionel 3201	99	—
99	DRIVIN' HOME	Jerry Smith	Decca 32679	98	—
100	GROOVY SITUATION	Gene Chandler	Mercury 73083	100	—

ALPHABETIZED TOP 100 (INCLUDING PUBLISHERS AND LICENSEES)

After The Feeling Is Gone (Cotillion—BMI)	97	Gimme Shelter (Gideon—BMI)	86	Make Me Smile (Aurelius—BMI)	52	Spill The Wine (Far Out—BMI)	57
Ain't That Lovin' You (East/Memphis—BMI)	69	Give A Woman Love (U.A.—ASCAP)	71	Mama Told Me Not To Come (January—BMI)	2	Spirit In The Dark (Pundit—BMI)	42
Apartment 21 (Wits End—BMI)	77	Go Back (Mee-Moo—BMI)	32	Maybe (NDM—BMI)	55	Steal Away (Fame—BMI)	44
Are You Ready (P.G. & E./Hexagram—BMI)	25	Good Morning Freedom (Maribus—BMI)	85	Melanie Makes Me Smile (January—BMI)	96	Stealing In The Name of the Lord (Tree—BMI)	95
Baby Hold On (Trousdate—BMI)	68	Groovy Situation (Cachand—BMI Patcheal—BMI)	100	Mississippi (Alchemy—ASCAP)	40	Summertime Blues (Rumbalero—ASCAP)	80
Ball of Confusion (Jobete—BMI)	3	Hello Darlin' (Decca)	91	Mississippi Queen (Upfall—ASCAP)	27	Sugar Sugar (Kirshner—BMI)	22
Band Of Gold (Gold Forever—BMI)	9	Hey Mister Sun (Green Apple—BMI)	37	My Baby Loves Lovin' (Maribus—BMI)	12	Sunshine (Don Dirshner—BMI)	62
Big Yellow Taxi (Sequomb—BMI)	94	Hitchin' A Ride (Intune Inc.—BMI)	6	My Marie (January—BMI)	53	Superman (Ides—BMI)	63
Boys In The Band (W.B./—ASCAP)	56	Humphrey The Camel (Back Bay—BMI)	46	No Arms Can Ever Hold You (Gil—BMI)	75	Sweet Feeling (Fame—BMI)	49
Canned Ham (Great Honesty—BMI)	34	I Just Can't Help Believing (Screen Gems, Columbia—)	46	D-D-H Child (Duckston/Kama Sutra—BMI)	24	Teach Your Children (Giving Room—BMI)	21
Check Out Your Mind (CAMAD—BMI)	26	If You Let Me Make Love To You Then Why Can't I Touch	59	Dverture From Tommy (Track—BMI)	16	Tell It All Brother (Sunbeam—BMI)	72
Cinnamon Girl (Cotillion—BMI)	96	You (Chappell—ASCAP)	82	Pearl (Low Twi—BMI)	70	That Same Old Feeling (January—BMI—Pickettywitch)	47
Close To You (US Songs—ASCAP)	18	I'll Be Right Here (Bryon—BMI)	64	Primrose Lane (Gladys—ASCAP)	60	That Same Old Feeling (January—BMI—Fortunes)	74
Come To Me (Big Seven—BMI)	65	It's All In The Game (Remick—ASCAP)	20	Que Sera Sera (Artist—ASCAP)	61	This Bitter Earth (Eden—BMI)	98
Come Saturday Morning (Famous—ASCAP)	51	Lay Down (Candles In The Rain) (Kama Ripppa/Alemanie—ASCAP)	4	Question (TRD—Andover—ASCAP)	19	This Bitter Earth (Seven—BMI)	31
Cottage Cheese (Yuggoth—/Forty Tunes—BMI)	88	Lay A Little Lovin' 'N Me (Unart—BMI)	54	Ride Captain Ride (ATM Music—ASCAP)	5	Tighter Tighter (Big Seven—BMI)	31
Daughter of Darkness (Felsted—BMI)	43	Letter, The (Earl Barton—BMI)	33	Save The Country (Tuna Fish—BMI)	28	Trying To Make A Fool Of Me (Nickel Shoe—BMI)	15
Destiny (Johi—BMI)	78	Let The Music Take Your Mind (Stephenye/Delightful—BMI)	92	She Cried (Trio—BMI)	23	United We Stand (Belwin Mills—ASCAP)	43
Don't It Make You Want To Go Home (Lowery—BMI)	67	Little Bit Of Soap, A (Melin—BMI)	66	Signed Sealed Delivered I'm Yours (Jobete—BMI)	19	Up Around The Bend (Jondora—BMI)	50
Drivin' Home (Papa Joe's—ASCAP)	99	Long And Winding Road (Maclean—BMI)	8	Silver Bird (Kangaroo—BMI)	29	Want To Take You Higher (Daly City—BMI)	41 & 84
End Of The Road, The (Jobete—BMI)	38	Loveland (Wright/Yesterie—BMI)	17	Sixty Minute Man (Lois—BMI)	83	When We Get Married (Frost—BMI)	30
Everything A Man Ever Needs (Insign—BMI)	79	Love On A Two Way Street (Gambi—BMI)	35	Sly, Slick & The Wicked (Julio Bryan—BMI)	81	Which Way You Goin' Billy? (Gone Fishin'—BMI)	11
Everything Is Beautiful (AHAB—BMI)	48	Love You Save, The (Jobete—BMI)	1	So Much Love (Van McCoy—BMI)	36	Wonderful You, The (Duchess—BMI)	10
Get Ready (Jobete—BMI)	7	Make It With You (Screen Gems/Columbia—BMI)	39	Song Of Joy (Barnegat—BMI)	15	Yellow River (Noma—BMI)	89
Gimme Dat Ding (Duchess—BMI)	14					Your Own Back Yard (Wedged Fat Zach—BMI)	87
						You've Been My Inspiration (Mullymood—BMI)	93



Would you believe  
what's happening  
Drac?

Yes Boris-It's No. 1  
telephone request wherever  
it's being played.  
(Even in TRANSANDIEGO)  
Calm yourself Parrot, you're  
stepping on my wing.!!!!

How can I be calm  
when we're selling  
so many records?

Master, it's  
coming back!!!  
MASH  
G-O-O-O-D!!

# Monster Mash

BOBBY (BORIS) PICKETT and THE CRYPT-KICKERS

348



Arranged and produced by Gary Paxton



*Memphis • Petula Clark*

Her new Warner Bros. album, produced by Chips Moman.

## Stax/Volt Ends G&W Ties; Exec Lineup Retained

NEW YORK — Stax/Volt Records will become an indie setup again on June 30, Cash Box has learned. This will end the label's association with Gulf & Western Industries, which purchased the company several years ago. It's understood that in the buy-back Jim Stewart, president, and Al Bell, exec vp, plus other key execs, will continue to operate the company. The label started internal billing as of June 25.



Columbia's Blood, Sweat & Tears, winners of three of this year's Grammy Awards, including that for Best Album of the Year, are breaking through some geographical and political boundaries as well. The nine-man group is currently engaged in an 11-concert, 26-day tour of Yugoslavia, Rumania and Poland and is the first contemporary American musical group to be sent under the auspices of the State Department's cultural program to Iron Curtain countries. Expressing the feelings of the group, lead singer David Clayton-Thomas has said: "I don't believe we are representing the State Department. We are representing young Americans who feel and behave the way we do."

Columbia is now releasing the band's third album, "Blood, Sweat & Tears 3." The group has been awarded RIAA/gold records for their first two albums, "Blood, Sweat & Tears" and "Child Is Father To The Man" and for their singles "You've Made Me So Very Happy," "And When I Die" and "Spinning Wheel". In addition to recording and touring, the group has composed and will perform the score for Barbra Streisand's new film, "The Owl and The Pussycat."

Group members are (l. to r.): Lew Soloff, Jerry Hyman, Fred Lipsius, Dick Halligan, Jim Fielder, Bobby Colomby, David Clayton-Thomas, Chuck Winfield, Steve Katz.

### INDEX

Album Reviews .....	33, 34
Basic Album Inventory .....	28
Coin Machine News .....	53-56
Country Music Section .....	41-44
Insight & Sound .....	37, 38
Looking Ahead (Singles) .....	29
New Additions To Playlist .....	22, 32
Radio Active Chart .....	30
Radio News Report .....	16
R&B Top 50 .....	36
Single Reviews .....	24
Talent On Stage .....	12
Tape News .....	20
Top Hits Of The Year .....	36
Top 100 Albums .....	27
Vital Statistics .....	39, 40

## Elektra's 'Age Of Maturity' Stresses 'Image' and Coping With Growth Plans

NEW YORK — Entering its own "Age of Maturity," Elektra Records is in the process of learning how to retain image values of the past while growing for the future. The label will celebrate its 21st birthday next year.

The day-to-day process of reaching this goal is now in the hands of Bill Harvey, general manager of the label, a function he's inherited from Jac Holzman, owner of the label who is now involved mainly in "visionary" aspects of the company.

Harvey feels he's charged with a "constant concern of maintaining Elektra's image," both as a label with strong ties to its acts and one with a responsibility to make statements regarding social conditions in the country (e.g. its recent trade ads on the theme of "Violence Ruins Us All").

"We have reached, however, a physical and mental plateau where we know where we want to go and how to get there," Harvey explains. One project is to enlarge the exposure of its product to include more AM radio coverage of its wares, in addition to long-standing FM exposure. To meet

### Harvey Decentralizes

this increased exposure, the label has just enlarged its promo dept., under Gil Bateman, with the addition of five "handpicked" field men.

Harvey also concedes that the growth or "maturing" of the label sort of "ivory towered" the company in the area of its artist relations. Elektra had always provided its acts



Harvey

with a "second home," Harvey notes, but growth factors, including a separation of functions on the east coast (administration) and west coast (recording) has necessitated a need to get to better "relate and have physical contact with our acts beyond the A&R staff." This will be accomplished through frequent visits by home office staffers to the label's west coast offices, headed by Russ Miller.

Similarly, Elektra hopes to provide more "guidance and expertise" for the many "unproven groups" it's planning on bringing on to its talent roster. Harvey emphasizes that this doesn't mean the company's venture into management, but a greater involvement in the acts it presents on recordings.

### Decentralization

A major part of Elektra's growth plans is a decentralization of function, a move mirrored in Harvey's recent appointment. The re-organization now under way ("to keep us as lean and strong as possible") is designed to strengthen each department.

(Cont. on Page 35)

## Alexenburg: Col Promo Is 'Communication & Credibility'

NEW YORK — "One of the comforts in working promotion at Columbia," Ron Alexenburg confides, "is never having to worry about where your next hit will come from." As national promotion director, though, Alexenburg is amply aware that having hit product at a label doesn't always mean having hit sales.

During his two years as the cornerstone of the promo force, he has had to build a vehicle for sampling reactions to new material, establishing credibility for the company's information and spreading exposure based on this data. Columbia's standing with a weekly showing of at least a half dozen singles on the Top 100 and 20+ LP's on the national chart attest to his effectiveness with this program.

Communication, Alexenburg says, is one of the chief success factors. Gathering details from the local men

and keeping each informed about the entire national picture has enabled Columbia's branch men to gain leverage with the product that seems most promising. "While every single released is treated as a national prospect," Alexenburg notes, "we watch the branch responses first. If the servicing shows national acceptance we work the material for immediate sales; and if a side doesn't break immediately, we'll watch for regional hit play and then see if this can bring about second-listens."

This practice has aided in getting the jump on a powerful single, but it has also given Columbia fuel for the longer work records. Among the recent breakouts are Ronnie Dyson's "If You Let Me Make Love To You" that has been built into a national hit after almost four months because of

(Cont. on Page 35)

## Cash Box Disk Jockey Poll On 'Most Programmed & Promising'

NEW YORK — Poll results that determine leading disks and record acts in the pop and country music field among the nation's deejays are in. The comprehensive survey is available in this week's publication of the 28th annual Cash Box International Directory.

In making the survey, Cash Box requested 5000 deejays in the Top 40, MOR and country music areas. The disk jockey poll is conducted through forms on which the deejays are asked to fill top 3 positions in a number of categories. They include "most programmed" and "most promising" over the past 12 months among records, albums, male vocalists, female vocalists, bands, vocal groups, instru-

mentalists (solo).

### Pop

The "most programmed" pop single is "Sugar Sugar" by the Archies (Kirshner), while the LP in this category is "Abbey Road" by the Beatles (Apple).

Among male artists, the winners are Tom Jones and Elvis Presley (tie); the winning female vocalist is Dionne Warwick; the winning vocal

(Cont. on Page 35)

### Lorenz Radio-Music Confab In Ontario

NEW YORK — George "Houndog" Lorenz, publisher of the "Behind the Scenes" tip sheet, is holding a "Scenes '70" confab that he describes as the first annual international radio-music conference at Niagara Falls, Ontario, Brock Hotel, July 16, 17, 18. He expects 500 tradesters to attend. For more information, Lorenz can be contacted at Behind the Scenes, 832-34 Rand Building, Buffalo, New York 14203.

## Atlantic Sues On Bootleg CSN&Y LP

NEW YORK — Atlantic Records has sued a brace of retailers both in New York and California and manufacturer Canyon Records — no relation to Wally Roker's Canyon Records — over sales of the bootleg recording by Crosby, Stills, Nash & Young called "Wooden Nickel". The firm has charged the stores and the manufacturer with copyright infringement and unfair competition. The record is a "live" recording of the group's performance at a concert in California. Atlantic is also applying for a preliminary injunction to stop the stores from selling the disk.

The stores sued in New York are The Gramophone, St. Marks Place and Discophile, Inc. (West 8th Street).

The C,S,N&Y bootleg recording of "Wooden Nickel" contains some songs that have not as yet been released commercially. It is being manufactured and sold without license or permission from Atlantic, or the artists or the publishing firm. Atlantic intends to vigorously prosecute any other retailers of the bootleg disc. The attorneys for Crosby, Stills, Nash & Young have already notified radio stations warning them about playing the disk.

## Top 100 Adds Dist. Feature

Beginning with this week's Top 100 singles chart, the record company distributing a label with a Top 100 disk will also be listed. This added feature of the chart reflects the increasing number of artist and/or producer labels that have associated themselves for distribution with other manufacturers.

### Canada Labels, Pubs

Aid Broadcasters

On Content Ruling

WB Aussy Formed

See Int'l News

**VIDCA: Chevy's Int'l Videt Cartridge Association**

See Tape News

HI! I'M SUSAN  
WITH A WONDERFUL  
NEW LP  
FOR  
EVERY  
CHILD!



**SUSAN**  
SINGS SONGS FROM  
**SESAME STREET**  
**STREET**  
JUST AS SHE DOES ON THE SHOW

©Leisure Sciences, Inc.

Produced and Arranged by:

Joe Raposo (1970 Emmy Award Winner for The Sesame Street TV Show)

Available on LP, 8 Track & Cassette

Check these "Sales Building" Merchandisers:

- |                                                                                                                 |                                                                             |
|-----------------------------------------------------------------------------------------------------------------|-----------------------------------------------------------------------------|
| <input type="checkbox"/> Total point of sale excitement created with 3 full color panels—in Unipak by Shorewood | <input type="checkbox"/> Mobiles                                            |
| <input type="checkbox"/> Co-op Ad Mats                                                                          | <input type="checkbox"/> Counter Cards                                      |
| <input type="checkbox"/> Giant Full-Color 2' x 3' Posters                                                       | <input type="checkbox"/> Aisle End Display Prepak—Life-Size Figure of Susan |
| <input type="checkbox"/> Full-Color 14" x 26" Streamers                                                         | <input type="checkbox"/> 2 Dozen Display LP Prepaks                         |
|                                                                                                                 | <input type="checkbox"/> Cassette and 8 Track—22 Unit Display Prepak        |

On Scepter Records  
SPS 584

**SCEPTER**

(212) CI 5-2170

# Capitol Industries' NY Building To House Its Eastern Operations

HOLLYWOOD — Capitol Industries, Inc. will centralize its various New York facilities and functions with a move into new offices at 1370 Avenue of the Americas when that building is completed late this year. The New York structure will be named the Capitol Industries Building to complement the firm's Capitol Tower corporate headquarters in Hollywood. The announcement was made by Stan Gortikov, Capitol Industries President.

## "Continuing Expansion"

"This action," said Gortikov, "emphasizes the continuing expansion of our New York activities. We chose this location after a careful search lasting almost two years. In our new facilities we will have more than doubled the space we currently utilize throughout the city."

Capitol Industries has entered into a long-term lease for 91,500 sq. ft. covering ten complete floors of the 33-story building. The company plans to use a major portion of the space and sublet the balance.

Oppenheimer Realty, Inc., New York, represented by Vice Presidents E. William Judson and Arthur Rosenbloom, were the exclusive leasing agents for Capitol and will also be in charge of the subleasing.

Executives and employees of various Capitol Industries divisions will be housed in the new East Coast center with the majority of the space occupied by Capitol Records. Commenting on the move, CRI President Salvatore J. Iannucci stated:

"We expect to reap numerous benefits from this fine new facility in the very heart of New York's entertainment industry area. In particular, the new location will facilitate dealings with top recording talent, agents, the television networks, and other vital aspects of artist management and development. A major factor will be Capitol's new, highly-advanced recording studios, utilizing the latest in 16-track recording equipment, to be

## Gortikov Predicts Strong Fiscal Yr. For Capitol Ind.

SAN FRANCISCO — For the fiscal year ending June 30, Capitol Industries expects to show significant profit and sales increases over the past year, Stan Gortikov, CI president reported last week (23) in an address delivered before the San Francisco Society of Security Analysts. "In fiscal 1969, Capitol had sales of \$153 million, net income of \$6.6 million, or \$1.52 per share, adjusted for the acquisition of Merco Enterprises, Inc. In the nine month period ended March 31, 1970, sales were reported at \$140 million and per share earnings amounted to \$1.66.

"We are confident that results for the full fiscal year 1970 will show continued improvement in sales and earnings," Gortikov declared. "We plan and prepare for continued growth in sales and profit for fiscal 1971. A most significant consideration is the economy and its effect on industry gains, and, therefore, our share of such gains. However, it is far too early for me to voice specific predictions with any adequate degree of credibility." The company president forecast a continuing growth in the sales of both cassettes and 8-track tape cartridges, which currently comprise about one-third of the company's long-playing product line.

## On Beatles

In commenting on recent activities concerning the Beatles, Gortikov said he is hopeful they will resume a creative relationship, will continue to make records as a group, as well as individually, and he noted that all such records must be released domestically through Capitol.

installed in the Capitol Industries Building as a replacement for our present recording facilities on West 46th Street. We expect to offer East Coast talent the finest recording facilities available in the entire industry."

Chief administrative officer of the new center will be Dick Asher, Capitol vice president of eastern operations. In addition to the expanded A&R functions, offices will be provided for sales, promotion, merchandising, legal, business affairs and administrative personnel of Capitol Records, Inc., Merco Enterprises, Inc., Audio Devices, Inc., and Beechwood/Capitol Music Publishing.

The building is owned by St. Andrews Associates, New York, and Emery Roth & Sons is the owner's architect. The building is being constructed by HRH Construction. The firm of Welton Becket & Associates, Los Angeles and New York, has been retained by Capitol Industries to design its New York office interiors.

## Scepter 'Sesame Street' Album Features 'Susan', Map Campaign

NEW YORK — With more than 100,000 advance orders already under its belt, Scepter Records is marketing this week its album titled "Susan Sings Songs From Sesame Street". The LP features selections from the nationally acclaimed educational TV series as sung by Loretta Long, who is featured about 60% of the air time of the smash TV series.

The disk was rush released in a deluxe, fold-open Unipak with 4 color art and will sell for \$4.98 suggested list, and will be backed by a massive merchandising and in-store promotional campaign as well as a co-op ad campaign. A cassette and 8 track cartridge will also be made available immediately.

### Major Promo Tour

As part of the major promotion, Miss Long (Susan) will begin making appearances in 18 major markets on July 1st. Cities include New York, Newark, Minneapolis, Milwaukee, Chicago, Detroit, Baltimore, Washington DC, Atlanta, Houston, Dallas, St. Louis, Los Angeles, Seattle, San Francisco, and possibly Denver, Cleveland, and Cincinnati. Personal appearances at each store will be supported by co-operative advertising, LP display



Ross, 'Susan', Greenberg & Goff

## London Sets A 'Full Scale' NY Sales Convention In September

NEW YORK — London Records is planning a major convention of all its distributors and regional and district sales and promo personnel in Sept. The full-scale, three-day conclave will take the place of the company's usual July regional distributor meetings, according to national sales and distribution manager, Herb Goldfarb, who is blueprinting the sessions.

Goldfarb feels the affair will be the first full-scale distributor convention the company has held in New York. "These meetings are being given class A priority all the way," Goldfarb asserted, adding that a number of dramatic new departures in both product and packaging are to be unveiled at that time. The sessions will be held at the Summit Hotel, commencing Monday evening, Sept. 14 and continuing

## Record Companies Draw Underground Fire At Alternative Media Project Gathering

PLAINFIELD, VT. — The Alternate Media Project laying the groundwork for a more aware and communicative media community held its first gathering on the campus of Goddard College here June 17-21. The meeting attracted and estimated 1,000 media people—both under and overground—and hundreds of young people from the New York and New England area, who were drawn to the conclave by rumors of a festival type atmosphere and the expected appearance there of several superstar rock groups.

The aim of the project was to work for ways "to facilitate direct communication among innovative broadcasting and record industry people." At Goddard, the aim was only partly realized. Lack of organization—it bordered on the impossible to obtain a program of events—resulted in an air of confusion. Another factor was the nature of the meeting place. The 600 acre Goddard campus was a pastoral enough setting but proved too sprawling for continued close-knit communication.

A general meeting, held during the latter part of the gathering, was addressed by Realist editor Paul Krasner. He spoke out against major record companies, accusing them of exploiting the youth market. This charge had also been made at a number of the project's workshops.

Several dozen of these informal workshop sessions were held at the four day convention. Topics included "The Recording Artist And The Community," "Radio Stations And Their Relationship With Record Companies," "Jazz, Blues And Classical Programming," "Record Production," "Selling Progressive Radio," "Rock Publications, Their Validity And Role" and "The Underground Press And The Record Companies."

On the last named subject, there was considerable discussion, both at the workshop session and in other informal gatherings. Since underground newspapers traditionally depend, to a large extent, on record company advertising, the editors of those publications face something of a dilemma, when they feel compelled to attack those companies for "youth exploitation."

Nevertheless, there were suggestions that the newspapers discontinue national ads in favor of those which relate directly to their own community. Record companies were also asked to kick back money into community projects as a penalty for their "exploitation" practices.

The convention was unique in that it drew the most important members of the underground media in the country. A special charter flight from San Francisco brought a West Coast delegation, and there was a good turnout on the part of Chicago and Midwest based media-ites, in addition of course to a representative group from New York.

Despite the disorganization, and a persistent rain which fell during the early part of the conference, the Alternate Media Project did set the stage for what, in years to come, may become a truly effective means of communication among the entire media community.

## Carlton Leaving Command/Probe

NEW YORK — Joe Carlton is leaving his post as vp and general manager of Command/Probe Records, the ABC Records division, effective this week (30). Carlton said he had reached an "amicable negotiation" of his contract with Sam Clark, group vp of ABC, and would pursue other opportunities. Carlton, who had operated Command/Probe for the past two years, exits the label following the shift of most of ABC's operations to the west coast. At Command/Probe, Carlton directed a program of developing contemporary acts on Probe, including the Zephyr, Rare Bird and Soft Machine. He also added a modern-sound touch to the Command label, one of biggest of the "sound" labels.

The vet music man's past associations include vp and A&R director for Mercury, a similar post at RCA, the formation of his own label, Carlton Records, and director of A&R administration for CBS Records. He joined Command/Probe in 1968.

## London Branches Add More Labels

NEW YORK — London Records factory branches in Chicago and Los Angeles have just acquired key new lines, according to Herb Goldfarb, national sales and distribution manager.

London Records Midwest has taken on both Buddha and Living Language Records, while London Records California has signed to distribute the MGM Family of labels, Vox and Turnabout.

## Prophecy Portends German Wave Next In Euro-Invasion

NEW YORK — While virtually all European acts to flourish in the United States thus far have been from Britain, Prophecy Records is now banking on Germany to provide the next wave of U.S. rock imports. With accent being given to on-continent rock by the Dutch acts that have scored here, Mickey Shapiro, Prophecy president, commented that "too many American record companies have simply looked upon Europe as a 'dumping ground' for excess U. S. product. But those labels that haven't, those that have viewed Europe as a creative market with something to contribute to American rock have been highly successful with product they've brought over."

Spotlighting the German work in contemporary rock, Prophecy is shortly to release two albums from a pair of German groups that have caught the attention of their homeland audience. Shapiro noted that this accomplishment is something of a surprise in itself since the Germans are generally skeptical of native talent performing blues or underground material.

In fact, he pointed out, in the case of one of the first two groups signed to Prophecy from Germany, the team would speak in its best English on stage before performances to overcome the indigent prejudice. On one occasion, a viewer asked members of the act where they were from, and on being told they were Berliners he replied, "well, I like your sound anyway."

First product in the drive by Prophecy will be LP's featuring Birth Control and Amon Duul. Birth Control has stirred interest in Germany with its first single and will shortly have its first LP release overseas as well as in America. Amon Duul is already represented by a strong selling LP in Germany.

Prophecy's product in the United States is distributed through agreement with Bell Records.

## Hy Grill Goes Into Indie Prod

NEW YORK — Hy Grill, vet music man and record producer, has resigned as A&R director for Kapp Records, effective immediately. He'll continue producing Kapp's number one artists, Roger Williams, on an independent basis. After a short vacation, Grill will plane to the coast for Williams' next recording sessions in early July. Upon his return, Grill will announce additional plans in his new role of independent producer.

## Sam & Dave Split

NEW YORK — Sam Moore and Dave Prater of the hit duo of Sam & Dave have ended their 10 year relationship. Moore has formed a new package called "Sam's Soul Together 1970 Review," which makes its debut this week (30) at Cheetah in New York. Featured with Moore are Brenda Jo Harris and a 16-piece orchestra. It'll be showcased for a week.

## Capitol Granted New Prelim Injunction In Tape Piracy Case

HOLLYWOOD — Capitol Records obtained another preliminary injunction last week, following a similar piracy action against a firm called Carrol. The second case, Capitol vs McGettigan, doing business as Car Stereo Center, resulted in another injunction granted by Oregon Circuit Court for the County of Multnomah. Actions are a part of the label's constant eye on the tape pirating of its product.

## Molten, New Canada Label, To Receive US Dist. Through MCA

NEW YORK — Molten Records, a newly formed independent record label from Canada, will have its first singles product distributed in the United States on both the Decca and the Uni labels, according to Jack Loetz, vp of MCA Records.

Molten is headed up by Wes Dakus and Randy Bachman. Bachman is featured singer with Canada's hit act The Guess Who. As a writer he was responsible for their hits "American Woman" and "These Eyes." Bachman is the composer and co-producer with Dakus of the first two single releases from Molten, namely "Wednesday In Your Garden" by Barry Allen which will be released here on the Uni label, and "Second Thoughts" by a new group called Cheyenne Winter which will be released on Decca Records.

Both singles have been recently issued in Canada on the Molten label and are getting very strong initial reaction. Molten Records is distributed in Canada by the Compo Company, a division of MCA, whose Lee Armstrong brought the releases to the attention of MCA Records International executive Dick Broderick in New York.

Molten is the first foreign label to be distributed in the U.S. under the newly created MCA manufacturing, marketing and distribution entity announced last week by Mike Maitland, president of MCA Records. Under the new marketing system, headed by Jack Loetz, all MCA record labels will be consolidated through the same channels of distribution with each label granted autonomy from a creative and planning standpoint.

## Fields Partnership Set w/ Sid Bernstein

NEW YORK — Sid Bernstein-Billy Fields Enterprises will be formed this Sept. as a result of a partnership arrangement between the two talent managers.

Fields, who joined Sid Bernstein Enterprises a year ago, was previously involved with Fred Weintraub in the management of such acts as the Four Seasons and Neil Diamond.

A key act nurtured by Fields within the Bernstein setup is 10 Wheel Drive. The Polydor group is regarded by Fields as unique in the jazz-rock band field in that its organization was not the result of individuals who had made a previous track record. Fields was met with a good deal of industry skepticism in keeping the act intact because of its 10-man makeup plus two road managers and the assorted equipment, including a sound system, that travels with the group.

## Zeitler To Scepter As Nat'l Promo Head

NEW YORK — Scepter Records has announced the appointment of Denny Zeitler as head of national promotion. He previously worked out of San Francisco with H. R. Basford & Co., distributors.

At Scepter he will be reporting to Steve Tyrell who moves up to vice president in charge of artists and product.



Denny Zeitler

## Jacobs And Cameron To Chess Regional Posts

CHICAGO — Chess Records has appointed Harry Jacobs to the position of east coast sales manager and Guy Cameron to the post of promotion manager for the southern region for Chess Records group of labels, including Chess, Cadet and Cadet/Concept. Jacobs will report directly to Arnie Orleans, national sales manager of Chess, Cameron to Chester Simmons, chief of promotion.

Prior to his appointment at Chess, Jacobs spent 25 years at David Rosen Distributors in Philadelphia where he handled sales of key accounts including special racks and major department stores.

Cameron comes to Chess from Shelby Singleton Enterprises (SSS International) in Nashville, where he was east coast regional promotion manager since January 1969. Previous to that, he was a disk jockey at WVOL in Nashville and WBLK-FM and WUFO in Buffalo.

But, Fields' faith in the team, particularly the writing talents (also arrangers) of members Eram Schefrin and Mike Zager and lead singer Gena Ravan, plus general support, financially and otherwise, from such people as Jerry Schoenbaum, president of Polydor, Hal Ray of William Morris and the firms Hill & Range, a co-publisher of the group's material, and BMI, helped keep the 10 Wheel Drive in motion.

Now, following their first LP, "Construction #1," a 75,000 seller, the group has just marketed its second LP, "Brief Replies," along with a single, "Morning Much Better." Fields says the second LP has sold 34,000 copies in the first week on release. The group is slated to make its first appearances in Europe, following the finalization of booking deals.

Fields is also high on two other Bernstein-Fields acts. One is singer Warren Marley, a native of Hawaii, who is debuting on the A&R label with "Los Angeles." Also, Fields is presently negotiating a record deal for an English act called Hands, Heads and Feet, represented by Danny Secunda, a nephew of Yiddish musical theatre composer, Sholom Secunda. Group, seen in the U.S. on the Tonight Show, among other video showcasing, features Tony Colton, guitarist, singer, writer. Colton is the writer of theme from the film, "A Man Called Horse."

Besides these acts, the Bernstein firm also manages the Rascals, discovered by Bernstein, and Rhinoceros.

## Donohue, Ross-Myring To West Coast Elektra

LOS ANGELES, CAL. — Corb Donohue has been appointed A&R administrative assistant for Elektra Records, according to Jac Holzman, president of the label. Donohue, who will be operating out of Elektra's West Coast office, was most recently a music columnist and reviewer for Daily Variety. In his new position, he will be responsible for scouting new talent.

Brian Ross-Myring has also joined Elektra's West Coast office in the capacity of chief engineer along with Bruce Morgan, who will be part of his staff. English-born Ross-Myring has been with Sunset Sound (he engineered the "Mary Poppins" track) and was, most recently, at Columbia Records for three-and-a-half years, where he engineered the Sly "Stand" and "Chicago" LP's among others.

## Joan Marlow Promoted To Beechwood Pro Mgr

BEVERLY HILLS — Beechwood Music Corp. has promoted Joan Marlow to the position of professional manager. Miss Marlow, with the publishers since November as West Coast catalog representative, succeeds Jill Williams, who has embarked upon a career as a recording artist. Prior to entering the publishing field, Miss Marlow taught and managed various recording artists.

## Songwriters 'Hall' Names 30 Nominees

NEW YORK — Ten of America's top living songwriters will become the first to be voted into the Songwriters Hall of Fame later this year. The special group to receive this honor will be selected by the balloting of all members of the Hall of Fame from a list of 30 nominees finalized last week during a special meeting of the board of directors. Irving Berlin and Richard Rodgers have previously been voted in by acclamation of the board. 52 deceased writers are also in the Hall.

Ballots will be mailed to the membership within the next few days, according to a spokesman, who added that to be counted, ballots must be returned no later than August 12, 1970.

The list of nominees, in alphabetical order follows: Harold Adamson, Harold Arlen, Irving Caesar, Sammy Cahn, Hoagy Carmichael, Benny Davis, Howard Dietz, Duke Ellington, Sammy Fain, Dorothy Fields, Arthur Freed, Rudolph Friml, Ira Gershwin, L. Wolfe Gilbert, E. Y. Harburg, Ray Henderson, Ted Koehler, Edgar Leslie, Alan Jay Lerner, Frederick Mercer, Mitchell Parrish, Andy Razaf, Leo Robin, Arthur Schwartz, Pete Seeger, Jule Styne, Jimmy Van Heusen, Harry Warren and Ned Washington.

Announcement of the 10 composers from this list elected to the Hall of Fame is expected to be forthcoming shortly after Labor Day.

## Juggy Sound Studios Now 'Sound Exchange'

NEW YORK — Orville Greene, owner and president of Juggy Sound Studios, reports that the studio name has been changed to Sound Exchange Studios, effective immediately.

Open to the industry since Jan. 1, The Sound Exchange was built at a cost of over \$200,000, and is located at 265 West 54th Street.

Greene also announced that Steve Katz has been named vice president and chief engineer at Sound Exchange. Katz, a graduate in electronics from N.Y. State University, had been an engineer with Gotham and A&R Recording before joining Sound Exchange. An additional \$75,000 has been invested in refurbishing the studio, adding an Ampex MM 1000 16 track Master Recorder and equipment designed by Katz. He is planning several non-profit industry services including a series of producer aids.

Recent sessions at the Sound Exchange include Wilbur Harrison's Sue LP, "Let's Work Together," Ike and Tina Turner; Joe Cocker for A&M; Steeplechase for Polydor; Jimi Hendrix, "Band of Gypsies"; Jake and the Family Jewels for Polydor and Buzz Linhart for Kornfield-Lang. John Mayall, Ten Years After and Eric Mercury also worked at Sound Exchange in recent weeks.

## Lovett To Pro Dept At Motown Pubberies

LOS ANGELES — Jobete Music (B. M.I.) and Stein and Van Stock (ASCAP), Motown's publishing companies, have announced the move of Leroy Lovett from the creative department to the professional department reporting directly to Herb Eiseman, newly appointed general professional manager. Lovett will concentrate on, and be responsible for, securing new recordings of songs from the pubberies' catalogs.

## Albright To Philips

NEW YORK — Albright has been appointed order service manager of Philips Recording Co's manufacturing plant in Richmond, Indiana, according to Robert Teitelman, v.p. and general manager of the company. Prior to Philips, Albright served with Columbia Records as manager of the custom department in Terre Haute, Indiana.



Christie's new  
single, "Yellow River,"  
has gone from 50 to 3  
in ~~four~~ weeks on the  
English charts.

Where do we go from here?



Where else?  
THE ORIGINAL HIT ON EPIC RECORDS.

IT'S EVERYWHERE!  
AND FOR OPENERS IT'S No. 89  
WITH A BULLET.



SEVEN

## Laura Nyro/Miles Davis

FILLMORE EAST, NYC — Two of Columbia's most creative and dynamic artists shared an unusual bill at the Fillmore East. And while the youthful audience obviously belonged to singer-composer Laura Nyro, it was the Prince of Darkness, Miles Davis, who provided many of the evening's most memorable moments.

Miss Nyro has written some of contemporary music's finer songs, a number of which have become top ten items. She has a commanding stage presence which gives considerable impact to her renditions. Accompanying herself ably on piano, sans other backing, she performed fully up to the expectations of her fans. Chalk up the Fillmore as another triumph for the multi-faceted Laura.

Something may be in the process of getting born these days out of the turbulent musical explorations of the current Miles Davis group. Though his sound was presented in very uneven offerings at the Fillmore, Miles himself played truly exciting and moving jazz figures, soaring to startling achievements amid energetic rhythmic patterns offered by his drummer, Jack DeJohnette, and bassist David Holland. The latter by the way is a fine musician, whether playing guitar or stringed bass.

Tenor and soprano saxophonist Steve Grossman's finest moments came from his efforts on the latter instrument. Grossman has heard much of John Coltrane, but this young musician has learned and not been overwhelmed by Coltrane's genius. Look for increasing excellence from Grossman and Holland. And, of course, from Mr. Davis, who is still the most interesting jazz musician extant. **d.l.**

## 'Hee Haw'

GARDEN STATE ARTS CENTER, HOLMDEL, N.J. — Radio Station WJRZ in Hackensack, New Garden State Arts Center, a striking semi-outdoor theater, and on Friday, June 19 we witnessed the "Hee Haw" night of the festival, which starred performers from the popular network C&W TV show.

Grandpa Jones led off the evening with his singing, banjo playing and humor. Grandpa hails from an age when country and folk music amounted to about the same thing, and though he is too much the entertainer to be accepted by present day folk audiences, his act, without the jokes and with a little less polish, might go over at the Newport Folk Festival. He's at his best as a foot-stomping, down home belter of old time country songs.

Singer and comedienne Mary Taylor was next on the bill. Miss Taylor is sort of the Carol Burnette of country music, and though her humor is at times a bit labored, she gets her laughs. Her singing is good, if not extraordinary.

Comedian Archie Campbell, seated upon a stool, delivered the sort of routines which have gained him fame on "Hee Haw." The most memorable was a re-telling of "Cinderella" in a special language akin to pig Latin.

Like Grandpa Jones, Hank Thompson hails from an earlier age in country music. But he's younger than Grandpa, and his style was developed after commercial country music had already gained a strong foothold. His act is straightforward and uncomplicated and somewhat out of date.

Roy Clark was the star of the show, and even if he had not been billed as such, a person who had never heard of him would have admitted his superiority. He generated the kind of excitement that only a star can. Probably one of the top two or three guitarists in country music, Clark has fingers as educated as the feet of a super-fast tap dancer. His voice is serviceable, and his sense of humor honest and unaffected. He's an effective showman and represents present day country music at its best.

Mention should be given to Hank Thompson's Brazos Valley Boys, who provided back-up chores throughout the evening. **j.k.**

## Ten Years After

### Catfish/Illinois Speed Press

FILLMORE EAST, NYC — Alvin Lee is truly a man possessed with the desire for complete perfection. It is unfortunate that he or anybody else for that matter cannot attain that level of achievement. But one thing is certain; that there is no stopping him in his drive for some unimaginable peak. There are those who feel he is on one of those Eric Burdon type ego-trips, and that is really too bad. A man possessed cannot be understood and should not be scrutinized from all angles. Rather just listen to him and what he says with his guitar and some of that understanding might come to the surface.

He repeatedly puts down his albums for the lack of what he feels are his and the groups capabilities. His or rather the groups latest offering is Cricklewood Green on Deram records, and for the first time the band seems to be a bit more satisfied. This might be attributed to the close contact with Leo Lyons his bass player and close friend for the past ten years. It can easily remind you of the relationship between Jimmy Page and Robert Plant of Led Zeppelin, though the latter is more into electronics. It wouldn't be very surprising if Lee started heading in that direction as a soloist or with Lyons, as he has

already past through jazz, blues, commercial rock and if I could use the term acid rock.

Anyway, as usual, he had the crowd standing on their seats as he went through his latest LP, with the addition of the always present "Good Morning Little School Girl." He finished with the now famous "I'm Going Home," and encoed with some Chuck Berry style "good old rock & roll." It seems that whatever he plays always get better with age and his offerings never become vintage, as some groups have the capability of ruining a song when performing it live. That's the ONLY way to really get into the foursome.

Other group members are the somewhat played down Chick Churchill who does the organ and piano work, and Ric Lee on drums, also one of the finest around, but playing in the shadow of Lee.

Preceding Ten Years After, was Catfish, a wanting imitation of Mountain, and The Illinois Speed Press. All that could be said about them is that it was a disappointing way to spend two hours waiting for the featured group. I would go on, but some things are better left unsaid . . .

**m.h.**

## Melanie/Brewer & Shipley

CARNEGIE HALL, NYC — A capacity crowd joined Melanie at Carnegie Hall for an evening of song. The artist offered a score of her most haunting, heart and mind-rending compositions. Sharing her visions and experiences in a way unlike that of any other performer, Melanie was spellbinding.

Playing her guitar with characteristic spirit, she gave some of her early material, "Close To It All," "Animal Crackers," "Uptown Down," the defiant "Tuning My Guitar," and the much-requested "Beautiful People." Items from her current hit album on Buddah included James Taylor's "Carolina On My Mind," the elusive beauty of which was captured, then gently freed by Melanie; "Citiest People," the endearing "Alexander Beetle" and, quite rightly, the exciting and anthem-like "Lay Down (Candles In The Rain)." Surrounded by several hundred fans who leaped to the stage, Melanie encoed with "Leftover Wine" and "Take Me Home."

Preceding her on the program were Brewer And Shipley, two young men from the midwest, with an exceptional talent for harmonizing and fine flair for a delicate brand of acoustic guitar accompaniment. From their debut Kama Sutra album came "Indian Summer," "Lady Like You" and "Witchi-tai-to" (which made us all feel like Indians, if only for a little while).

**e.k.**

## Grand Funk Railroad Mott The Hoople/Kinks

CAPITOL THEATRE, PORTCHES-TER, N.Y. — Mott The Hoople, another English offering, unfortunately are not the same group in person as they are on album. Not to many people are familiar with them as yet. First of all, they are a very talented group, but much too loud on stage. It is true that their material is a bit better than they are, and that could effect them in a number of ways. It might be that I am spoiled by the number of good groups around, but I really wasn't very impressed by them.

Following them were the very surprising Kinks. They also ran through their new album, "Arthur," and quite the contrary to Mott The Hoople, do their LP material much better in person. They highlighted their segment with some of their early, and much

## Ian & Sylvia

TROUBADOUR, L. A. — Anyone who had been expecting a 'new' Ian & Sylvia was probably let down when the husband and wife country/folk duo opened a week's stand at the Troubadour last week, but anyone who came to hear the old sound was richly rewarded. For some unexplained reason, the duo's first album for Ampex made it look like they have merged their identity with several other musicians to become the Great Speckled Bird, but, in truth, no such merging occurred.

Sure, Ian & Sylvia have the help of four talented musicians, but that's been going on for well over a year now. Sure, Sylvia was wearing an orange jumpsuit instead of her 'cutesy' short skirts, but that didn't turn her into Grace Slick. What really went down was what has been going down for a long time: a good helping of down home (in this case, Canada) music.

Though several new songs were introduced, it was the older material, such as Tim Hardin's "Reason To Believe," or their own almost hit, "Lovin' Sound," or Ian's "Someday Soon" (a recent hit for Judy Collins) which went over best. The two encore numbers, Johnny Cash's "Big River," with a vocal assist from bassist Jim Colgrove, and "Smiling Wine," were also strong. All in all, it was a nice set, but methinks they saved their good material for the next set. **a.r.**

superior material. These included songs like, "You Really Got Me," and "I Need You."

The main attraction was The Grand Funk Railroad, and they played their last LP, Grand Funk, in their usual, crashing style. Some performers can constantly get away with showing off one member of the group, but when the bass player Mel Schacher leans against his amplifier throughout the entire performance and drummer Don Brewer cannot be seen at all, well something is missing. They entirely show-off lead guitarist and lead vocalist Mark Farner.

I did see them a few months ago when the album was riding the charts very honorably and liked them. Saturday night, my only thought was — when is it all going to end? They did their heavy songs like, "Paranoid," and "Inside Looking Out," and some other overly-used material. Their brand new album, "Closer To Home," has received great reviews, and I can't understand why they failed to into it. **m.h.**

## Robin McNamara

FACTORY, L. A. — "Hair" has already contributed more than its share of goodies to the music business, but it's far from dried out. Newest contribution is in the form of artists, namely one Robin McNamara, who looms to be one of the most important entertainment finds of the year.

It should be noted, in all honesty, that McNamara's hastily arranged showcase at the Factory, backed by the house band, was not the music event of the year, and yet, despite all the drawbacks, he came thru with flying colors, leaving one to hope that he will follow the Joe Cocker formula and assemble a group of really talented and creative musicians to work with him.

Robin already has a head start over fellow "Hair" performers Bert Sommer and Allan Nichols (who are also headed for bigger things) due to his current Jeff Barry-produced hit, "Lay A Little Lovin' On Me" (Steed). In addition, he is pure entertainment, movin' and grovin', pouring on the steam to get his audience swinging with him.

Having only twenty minutes to rehearse with your group limits your choice of material somewhat, so we'll dismiss the overdone "Feeling Alright" and praise an old Van Trevor ballad, "I Want To Cry," that McNamara dug up somewhere and turned into one of the most moving experiences we've heard lately. His own composition, "Beer Drinking Man," was also a winner.

But, as we've been saying, far more important than what Robin McNamara did at the Factory last week is what he's going to do in a lot of other places in the weeks to come. **a.r.**

## Dick Gregory Esther Marrow

VILLAGE GATE, NYC — It's understandable that regular television viewers of evening newscasts can't find much in current political events to laugh about. For those sensitive to society's problems but weary from the depression that frequently accompanies such concern, Dick Gregory's comic routines are perfect therapy.

As both a political activist and comedian, Gregory is able to penetrate issues deeper than most comics, who dwell on such superficial items as the looks of a president's daughter or a vice president's tendency to misdirect golf balls.

The Poppy recording artist delivered predictable digs at vice president Agnew and the Cambodian invasion, but it was during his ad libbing with audience members and his relating of ghetto experiences that his comic genius was outstanding.

Particularly hilarious were Gregory's constant references to his cousin "Cuz," through which he related events in an earthy, simplified perspective of a slick ghetto dweller, and Gregory's business venture during high school when he and a friend sold imitation reefers cut with horse manure.

Gregory's material is largely political, but appeals to the intellect and funny bone rather than to fears or prejudices. To laugh uproariously with Dick Gregory is by no means to patronize Gregory, who is unquestionably one of the nation's sharpest comic minds.

Preceding Gregory was high-powered songstress, Esther Marrow, who performs with the emotion and vocal expression of a traditional blues singer. Her deep, full, piercing voice produced stirring treatments of "Rainy Night in Georgia," "When I Die" and a moving "Trade Winds," a soulful ballad of societal corruption.

**j. r.**



CLOSER TO HOME

The third album,  
available now on  
Capitol - Record and Tape

(SKAO 4771) Produced by Terry Knight

**Close  
To  
Home**



... searching to find a way to bring us all closer to home.

## Brotherhood-Winley Label Formed In NY

NEW YORK — Brotherhood-Winley Records has been formed by Paul Winley, president of the new setup based at 409 West 125th St. in New York.

The company, Winley said, will specialize in training and recording talent for its own labels. Four artists have completed recording sessions: Earl Wright and Douglas Haynes are set for releases soon, while the Week-nights and the United Movements are to be released at a later date.

Besides Winley, the exec lineup includes: Ann Winley, vp; Harold Winley, national promo director; and David Winley, controller. Company's phone numbers are (212)-9198; 9199.

## Elektra Host Of ARD Dinner

NEW YORK — Elektra Records hosted a dinner for the Association of Record Dealers, an organization made up of retailers and one-stops in the New York area, at Al and Dick's Restaurant on Tuesday night, June 16.

In addition to Elektra President Jac Holzman and general manager Bill Harvey, other record company execs attending the occasion were Buck Rheingold and Ed Charles of Buddah Records and Cy Spiegeman of Ramwood. Also present were Dave Seidman of Futura Tone Distributors, Jerry Winston of Wendy Distributors, and ARD President Mickey Genzler.

Following a discussion of upcoming Elektra product, Elektra President Holzman spoke about ARD's membership's ability to help record manufacturers to promote new artists. "ARD can become an essential force," said Holzman, "in keeping the life's blood of the industry flowing with new talent."

Harvey offered Elektra's services in making ARD a more effective organization.

## Filmation Sets 'Goolies'; New TV Musicomedy

HOLLYWOOD — Music continues to be the thing on Saturday mornings, and Filmation, who started the trend rolling with the Archies two years ago and followed with the Hardy Boys last year, have another new musicomedy show ready to roll in the fall. Titled "The Groovie Goolies," the show will be a monster laugh-in starring Dracula, Frankenstein and the Wolfman as three lovable characters who double as a rock and roll group.

Dick Delvy, who was West Coast administrator for MGM/Verve before the Mike Curb takeover, was selected to produce the songs for the new show and all 36 sides are already in the can. A label deal is currently being worked out.

Norm Prescott, Filmation exec, noted that the Archie series, which has only been using 17 songs a year, will introduce 51 songs next season. A new feature, "Archie's Giant Juke Box," will be used to showcase the tunes. Songs for the Archie show will continue to be produced by Jeff Barry under the supervision of Don Dirshner. The Archie Comedy Hour, going into its third year, has been guaranteed a five year run.

### Bootleg Archies

Although recent 'bootleg' Archie

## DRK Agency Bows

NEW YORK — DFK, a new advertising, marketing and sales promotion agency, has opened its doors at 588 Fifth Ave. The agency, headed by Sy Davis, Herb Fried and David Krieger has among its accounts Stax Records, Volt, Enterprise and Respect; Jerry Ross Record Productions, with the Colossus and Heritage labels; and the concert groupings of Ed Stimler and Edwin Frederick Productions.

groups have been touring the backwoods sections of the country and raking in heavy money, Prescott does not regret keeping the Archies as a studio group only. "Every generation for the last 30 years has grown up with the Archie comics and we felt that if we created a group that did not look exactly like the kids that they were used to seeing, a psychological negative would set in and there would be a tremendous disappointment that might hurt the property in the long run, even though it might bring in a lot of quick money in the beginning. To us, the basic property was more important than trying to pick up some fast money on a bunch of kids who would go to see the Archies once. But to disappoint them and take away the illusion of these cartoon characters wasn't worth it to us if we want to perpetuate the value of the television show. We probably threw away a half-million dollars in bookings."

The Hardy Boys are a live group, and appear live on the song segments of the show, even though the remainder is cartoon. The Goolies will be live all the way, and in addition to the original group making personal singing appearances, there will be 'touring' companies of Goolies making non-singing appearances at promotional functions.

For the 1970-71 season, Filmation will have 2½ hours of Saturday morning shows, including one non-musical show. "Will The Real Jerry Lewis Please Sit Down." Co-starring with the Goolies in their show will be Sabrina, the Teenage Witch, who vacates her portion of the Archie Comedy Hour. The Goolies show will also feature 'visiting' groups such as the Rolling Grave Stones and the Mummies and Puppies. All in all, it'll be a great year for music on TV.

## AIR's Sherlock On Promo Tour

HOLLYWOOD — George Sherlock, American International Records general manager, has left for an extended promo tour for the AIR label, including meetings with local radio station deejays and branches of Transcontinental Record Corp., AIR's national distrib.

His itinerary during the next 10 days will feature stays in Phoenix, Denver and Salt Lake City.

Meetings will cover AIR's current releases: the original motion picture soundtrack recording of "Bloody Mama," and a new single pulled from the album entitled "Rembrandt," scored by Don Randi; AIR's contract recording artist Judd Hamilton's initial album and single release entitled "Someday Morning." The Source's new single, "It's Me I'm Running From," featured in the release "A Bullet For Pretty Boy," which stars Fabian Forte, Jocelyn Lane, Astrid Warner and Adam Roarke.

## Danny Kaye Stars In Rodgers Show

NEW YORK — Danny Kaye, who left Broadway 29 years ago to become a Hollywood star, is returning to the main stem this fall as the lead in Richard Rodgers' new musical, "Two By Two." Kaye will play the role of Noah in the adaptation of Clifford Odets' last play (1954), "The Flowering Peach." The musical will have a score by Rodgers, with words by Martin Charnin, and a book by Peter Stone. Rodgers is producing, Joe Layton is directing. Kaye last appeared on Broadway in Cole Porter's "Let's Face It" in 1941. He took Broadway by storm shortly before in Kurt Weill and Ira Gershwin's "Lady In The Dark." No cast LP assignment for "Two By Two" has been made.

## Capitol Exec Tops Summer Music Shop

HOLLYWOOD — A Capitol Records exec will be the conductor for a special summer music workshop for young musicians in the Los Angeles area.

Donald E. Stevens, a graduate of the Eastman School of Music, Rochester, New York, and director of accounting at Capitol, emphasizes that the program will provide young musicians with an opportunity to develop their talents over the summer months as well as fulfill a need for a lack of such instruction in the area.

The program, to be held as part of the Saturday College of East Los Angeles, is open to all intermediate and advanced young musicians of high school age and above. It will culminate with the recording of a 12 inch album tentatively titled, "Music of the Americas," exemplifying the richness of music cultures in the Western Hemisphere. The course will cover practice and experimentation in recording techniques, broad exposure to a wide variety of repertoire, and useful exercises for the improvement of intonation, technique, and tonal quality.

Those interested should call the college at 263-7261, Extension 224. Registration is June 27. The program runs July 11 - Aug. 22.

## Atlanta NARAS Membership Drive

NASHVILLE — The Board of Governors of the Atlanta NARAS Chapter voted at their recent meeting to begin an extensive membership drive that is to climax with a social-business function at the end of the Summer. Wade Pepper was selected by the board to serve as Chairman of the first membership committee. Serving with Pepper on the membership committee will be Mary Tallent, Maurice LeFevre, Gy Waldron, Larry King, Gwen Kesler, and Herb Lance.

It was also announced that the Atlanta Chapter will host the national trustees meeting Sept. 12-13.

COMING SOON

EPIC

MADE IN U.S.A.



APPLE LUAU — Pete Bennett of ABKCO Industries and Apple Records, gets together with friends Glen Campbell, Sal Ianucci, president of Capitol Records, and Al Martino, at the Capitol convention in Hawaii.



# Certron's Got It Together

*...presenting our first exciting, all new album release,  
supported with strong advertising and merchandising programs.*

*The progressive, innovative, creative, turned-on company—*

**CERTRON CORPORATION MUSIC DIVISION**

1226 16th Avenue South • Nashville, Tennessee



ALSO AVAILABLE ON 8-TRACK CARTRIDGE AND CASSETTE CARTRIDGE.



## Tuning In On . . .

### KEX-Portland, Ore. 'We Stress Entertainment'

Programming which involves extensive community action and an air-time accent on entertainment has proved to be a winning combination for KEX-Portland. The 50,000 kw. station has developed a "hip MOR" format which, by drawing from both the young and the old audience, has also played an important part in its success story.

On the public involvement front, KEX maintains a good and continued relationship with the citizenry. The station broadcasts editorials daily and calls attention to many local activities through spots, specials and active participation of airtime personalities.

Recently KEX co-sponsored a Project Thank You, which raised more than \$18,000 for gift packs to be sent to servicemen in Vietnam. A benefit softball game featuring the KEX staff raised a total of \$2500 for a young Portland man who had been seriously hurt during a school wrestling match.

When a large naval fleet sailed into Portland harbor, it was met by a KEX press boat. A "Dirty Picture" promotion called attention to the pollution problem by asking listeners to send in photos of particularly high refuse pile-ups in the city. Morning man Barney

Keep, a veteran of 25 years at KEX, was responsible for lighting up nearby Mt. Hood for the benefit of the Apollo astronauts.

On the lighter side, jock Bob Swanson ran a "Radio Romance," personally matching up singles with similar

**KEX-Portland, Oregon. 50,000 kw. Fulton Wilkins, v.p. and general mgr.; Vic Ives, program dir.; Richard Kale, sales mgr.; Larry Anderson, promotion mgr.; Jim Hollister, music dir.; Jim Howe, news dir.**

**Format: Contemporary MOR; Playlist: approximately 40 singles, 10-15 albums, some oldies.**

**On-Air-Personalities: Barney Keep, 6-10 a.m.; Ric Thomas, 10 a.m. to 1 p.m.; Bob Swanson, 1-4 p.m.; Hal Raymond, 4-7 p.m.; Art Smart, 7 p.m. to midnight; Russ Conrad, midnight to 6 a.m.**

interests. Response to this was excellent since computer dating services are illegal in the state of Oregon. Swanson brought his couples together at a KEX sponsored dance held in a Portland theatre. To date, four marriages have taken place as a result of his playing Cupid.

"Latitude within certain frameworks," is music director Jim Hollister's phrase for the station's policy regarding on-the-air personalities. "We encourage the guys to be themselves. Our jocks are not all in one age group and each one brings a different approach to his time slot." The deejays work from a playlist which, although it is relatively tight, is changed often.

KEX has moved to the forefront among listeners in the 25-49 age group. The playlist ranges from MOR type numbers such as "Close To You" to the rocking "Mississippi" deck by John Phillips. Each Saturday night, the accent is placed firmly on oldies with these decks comprising 50% of the disks heard.

The station also relies on a great deal of pre-produced comedy material. These brief bits feature the KEX air staff and are easily programmed in with the recorded music. Other off-beat features crop up from time to time, and the station boasts of having the only lady helicopter traffic reporter in the U.S. Known as Sheila, Queen Of The Sky, she is heard twice daily.

"Music is an important part of our programming," says program director Vic Ives, "but we also stress entertainment for its own sake. We aim at being bright, entertaining and fun."

### Gavin Names Burkhart

BEVERLY HILLS — A special Awards Committee has been appointed for the Sixth Annual Radio Program Conference by its director, Bill Gavin, with Kent Burkhart, executive vice president of Pacific-Southern Broadcasting, Atlanta, to serve as chairman.

Joining Burkhart will be Conference Advisory Committee members Pat O'Day, general manager, KJR-Seattle; Johnny Hyde, manager, KRBT-FM, Woodland, California; Harold Lipsius, president, Jamie/Guyden Distributors, Philadelphia; and Janet Gavin, The Gavin Record Report, San Francisco.

Responsibilities will include final development of categories and balloting methods for awards to be presented broadcasting and recording industry leaders at the non-profit Conference, set for Nov. 20-21-22 in Los Angeles.

### STATION BREAKS:

Hal Moore, after brief sabbatical in Mexico, will again be heard in afternoon drive time slot on KHOW AM and FM, Denver . . . Jack Ambrozic appointed to newly created post of general sales mgr. of WNCR-FM, Cleveland . . . James Stoke added to WIOD-Miami airstaff as new mid-day personality.

Indiana Broadcasters Assoc. held their mid-year meet this week, with former FCC commissioner Lee Loevinger, the keynote speaker . . .

Projected date for completion of KMPX-San Francisco's new studio and production facility: Sept. 1 . . . Larry McCormick named program mgr. at KGFJ-Los Angeles, succeeding the late Jim Randolph.

Whitney Productions has named R. T. Williams, former exec. producer with WQXI-TV, Atlanta, to position of production staff director.; appointed operations mgr. for Whitney was Jack Leary, most recently program dir. for WAJA-TV, Miami . . . KMPC-Los Angeles reports they've handed out \$12,800 to date in "Home Run For The Money" contest.

"Outdoor Sports," new series debuts on WKYC-TV, Cleveland July 5, to run through Sept. 6 . . . WBCR, the voice of Brooklyn College, claims to be first station in U.S. to play the new Blood, Sweat And Tears album, which they did Wednesday (24) afternoon . . . Public Service revamp at WABC-New York headed by new talk-interview telephone show, "Conference Call," which bowed June 21.

WCFL-Chicago's Mike Rollins has released "Dissent" b/w "Peace," two songs he co-authored with station's record librarian Howie Beyer . . . WAVZ-New Haven wound up their highly successful mustache growing promotion . . . Commemorating radio's golden ann'y. — WIOD-Miami airing "time capsule," featuring highlights from radio's past.

KEX-Portland, Oregon's Barney Keep selected "King Of Fun," in city's rose festival parade . . . College student Dennis Beverage began summer internship in KNX-Los Angeles newsroom . . . Rousing climax to WBML-Macon, Georgia's "Which Announcer Would You Like To See Hit In The Face With A Pie" promotion was just such a smack for program dir. Don King.



THE LINE-UP outside studio of KFRC-San Francisco includes the Epic recording group Poco. From left to right, George Grantham, Rusty Young, both of Poco; David Banks, Epic promotion mgr. in San Francisco; Carole Archer, KFRC music librarian; deejay Mike Phillips; Richie Furay and Jim Messina of Poco; Ted Atkins, KFRC program director; deejay Don Kelly.

Upcoming 30 minute musical special will showcase members of WLWT-Cincinnati's talent staff. Featured will be Bob Braun, Paul Dixon, Kenny Price, Marian Spelman, Colleen Sharp, Bonnie Lou, Dave McCoy and Nancy Dawn . . . Former olympic champ Paul Drayton named desk assistant for NBC News Bureau in Cleveland . . . Fred Sanders appointed sales services coordinator at WIOD-Miami . . . Bob Felix and Cynthia McPherson are recent additions to KGFJ-Los Angeles news staff . . . Stan Dale launched his new program, "Confrontation," on WLS-Chicago.

KLAC-Los Angeles readying July 4 weekend, to include three day "music spectacular," new commentary feature and fireworks celebration . . . While Phil Donahue vacations, his show will be series of ten viewer-favorite programs from past year.

### ENERGETIC ATTORNEY

Six years music business and related entertainment experience — desires responsible and engaging position as attorney or executive with law firm or entertainment organization.

Write: Box 878

Cash Box  
1780 Broadway, N.Y.C. 10019

Where  
The Music  
and  
Entertainment  
People  
Meet  
To See  
and  
Be Seen

## Spindletop

IDEAL FACILITIES FOR ARTISTS' PROMO PARTIES

CALL YOUR HOST  
VAN RAPOPORT  
254 W. 47 St. Cl. 5-7326



BOTTLE POWER — During their current cross-country tour to promote their new single "Sorry Suzanne" from their recently-released album, Avco Embassy's The Glass Bottle (back row) performed at The Embers in Nashville. Arrayed in front of the group (l. to r.) WLAC deejays Eddie Parker and Bob Sticht with Luigi Creatore, Avco Embassy vice president and chief operating officer.

# PRIDE

is very often an elusive commodity in the record business.

At Lizard, we have a new artist of whom we are very proud. His new album is called "No Apologies." We commend it to your attention. His name is



# NOLAN



## WHAT THE CRITICS ARE SAYING:

"Nolan Porter is the most exciting male singer I've heard since the world first discovered Mick Jagger."

"There is magic in this debut album. It's the kind of record you can't help but respond to on both a physical and emotional level."

"... Certain to be one of the most important new singers in the wide field of popular music."

"The most compelling feature of Nolan's vocal performances is his astounding versatility. On different cuts you can detect some of the flamboyance of James Brown, the soul of Otis Redding, the poetics of Donovan, and the clean joyous economy of John Sebastian. But for overall feeling, I have to say that Nolan evokes the same kind of raw response that I first got from Ray Charles before he made the switch to country and western."

—Chris Van Ness



A Lizard Records Production

**AMPEX**  
RECORDS

Distributed by Ampex Records,  
Available on Ampex  
Stereo Tapes.

## Milestone Revamps Distrib. Network

NEW YORK — Milestone Records has completed re-organization of its domestic distribution network. Most recent changes are the label's switch to Summit Distributors for Chicago and Cincinnati, the new Music Merchants of New England organization for that area, the new Bilbo Distributing in Detroit, and Huffine in Seattle. Continuing as Milestone distributors are Merit (Los Angeles), H. R. Basford (San Francisco), Empire State (New York), A & L (Philadelphia), Apex-Martin (Newark), Zamoiski (Baltimore), Music Sales of Florida (Miami), Main Line (Atlanta), Globe (East Hartford), NMC Corp. (St. Louis), Brother's (Cleveland), Aden (Minneapolis), Pan American (Denver). In some secondary markets Milestone deals directly with jazz-oriented retailers or works through sales rep Larry Sockell. Canadian and world-wide release of Milestone is through CBS International, except for the Far East, where the label's outlet is Victor Company of Japan.

## Scepter U.S. Rights To 'Doctor Tom' Single

NEW YORK — Scepter Records has acquired U.S. releasing rights to the Canadian single, "Doctor Tom," by the group, Freedom, which was released in the Dominion on the Acquarius label.

Negotiations leading to the American disc deal with Scepter president, Florence Greenberg, were handled by Bert Siegelson exec of Felsted Music, which at the same time acquired world publishing rights on the song, exclusive of Canada, from the Canadian publisher, Summerlea Music of Montreal. Felsted is part of the London Records publishing division.

The recording was produced by Much Productions and will be issued in the U.S. under the group name, Freedom of Choice.



**LLOYD IN THEIR KAPP** — Jazz artist Charles Lloyd (c.) has signed a long-term contract with Kapp Records. The agreement was personally negotiated by MCA Records proxy J. K. Maitland (l.) and Kapp's general manager Johnny Musso (r.). The three are shown discussing plans for Lloyd's upcoming "concept" LP release for the label.

## \$50,000 Ad Budget Will Support Okun's 'Great Songs Of 60's'

### Book Of 80 Songs From N.Y. Times

NEW YORK — Milt Okun's "The Great Songs . . . of the Sixties" will be the first book published by the New York Times without a publishing association with another book publisher. However, the newspaper's publishing division, Quadrangle Books, has made a sales and distribution agreement with Random House on the book, according to Herbert Nagourney, associate director of the Times' book division, which will support the book with a \$50,000 ad campaign, considered a hefty figure in the book field.

The book, arranged for voice, piano and guitar, will contain 80 songs covering the rock, soul, jazz, the movies,

protest, folk and Broadway. Okun, the vet arranger, musical director, disk producer and folk musicologist, noted, however, that "those whose absence would absolutely preclude the book being called the great songs of the sixties are: Lennon & McCartney, Bob Dylan, Paul Simon and Bacharach & David."

The book, 9" by 12" with a special spiral binding to allow it to be placed easily on a piano or for guitar, will be available in the fall with a first printing of 30,000 copies. It'll be priced at \$14.95 until Christmas, \$17.50 thereafter. Tom Wicker, associate editor of the Times, has written an introduction.

Okun, producer-arranger-musical director for Peter, Paul & Mary, Harry Belafonte, the Chad Mitchell Trio, among others, has also edited a best-selling book, "Something to Sing About," later tied-in with a 3-LP set of the same name.

## George Bennett Dies

NEW YORK — George Bennett, vet public relations man, died last week (24) in Doctors Hospital in New York at the age of 53. Since 1961, he has been president of Bennett Public Relations in New York, operated in association with his brother, Bernie Bennett. Some of the firm's clients include Eddy Arnold, Al Hirt, Kate Smith, among others. Bennett is survived by his brother, his parents, Mr. and Mrs. Louis Bernstein, two sisters, Miss Gert Bernstein, and Mrs. Edward Kaplan. Funeral services were held last Friday (26) at Philip Apter & Sons Funeral Home in Maplewood, N.J.

## Randall To Studio For Polydor Album

NEW YORK — Guitarist Elliott Randall has begun recording his debut solo LP. The as-yet-untitled album is slated for release in September on Polydor Records, and features new material written by Randall and Paul Fleisher. The LP is being co-produced by Randall and Eddie Kramer.

Before working as a solo artist, Randall appeared as a member of Sea Train and later Eric Mercury Birthrite.

## TIC May Offer Shares Of TMC

NEW YORK — Bob Lifton, chairman of the board of Transcontinental Investing Corp., told stockholders at the company's annual meeting held here last week (25) that the individual parts that make up Transcontinental "are considerably more valuable than the current market price our company indicates."

The make-up of the company consists of The American Bank of Commerce, North American Acceptance Corporation and the Security Mortgage Investors' stock it owns, and Transcontinental Music Corp. The balance of the company's holdings consists of real estate and other investments.

"Therefore," he said, "we are re-viewing ways of enabling our shareholders to participate directly in the component companies through a spin-off or other distributions of shares. For example, we are currently exploring ways to permit the distribution of TMC stock to our stockholders. Based on the current direction TMC is taking, the shares distributed could prove highly valuable."

"As part of such a program we also have in mind the sale of the American Bank of Commerce at a price which will allow us to repay the relatively small long-term debt we carry," he added.

"These steps," Lifton said, "would leave Transcontinental debt-free. Its net worth would be over \$65 million in addition to its holdings in Security Mortgage Investors which has a current market value of approximately \$16 million. It would also be in an excellent cash position to concentrate on its finance and land development activities."

"The combination of TIC and TMC stock, which our shareholders would have as part of such a program, could have a much greater worth than today's market value," he said.

In discussing 1970 Mr. Lifton said that it would be inappropriate to compare the company's earnings flow on a quarter-by-quarter basis with 1969. "This year we expect the earnings of TMC to follow a different pattern with lower earnings in the first three quarters and a sharp upswing in the final quarter. Also in 1969, the company profitably sold some of its holdings in the first two quarters. This year the counterpart of that activity, namely the extension of our real estate operations into land development will probably reflect mostly in the company's third and fourth periods."

"In view of these facts and the general economic situation, including the prevailing money market," Lifton said, "it was impossible to predict the level of the company's earnings for the year."

He pointed out that since the company was formed in 1961, net worth has increased six times, gross income has multiplied over nine times and earnings have quadrupled. "I think the decade ahead will see greater growth whether as a single entity or as a combination of component companies spun off to our shareholders."

## Credit Jerome

HOLLYWOOD — Henry Jerome should have been credited with the production of Bobbi Martin's "With Love" single and album and new "Give A Woman Love" single in a Liberty/UA ad that ran in the June 20 issue. His name was inadvertently left out of the copy submitted to us.

## NGC Inks Pact With North Beach

LOS ANGELES — National General Corporation's newly formed NGC Records, has signed a recording contract with Tom Donahue's North Beach Productions. The San Francisco based company will release four groups exclusively through NGC Records.

The first release by North Beach Productions on the National General label is an album by English group, Silver Metre. The group arrives in the U.S. this week for their first national tour, which will kick off on the East Coast.

**10,000,000  
beautiful record  
buyers  
believe in him.**



1650  
BROADWAY  
Corner 51st Street

A FEW DESIRABLE  
AIR CONDITIONED OFFICES  
WILL BE AVAILABLE OCTOBER FIRST

**THE  
DILLIARD  
CORPORATION**

Miss E. Kunzman  
Plaza 7-4400

From RANWOOD RECORDS,  
the instrumental hit!

R8076 • STEREO

A  
**SONG OF JOY**

*The* **FOUR-SCORE** *Pianos*

**RANWOOD**  
RECORDS, INC.

RAINDROPS KEEP FALLIN' ON MY HEAD  
O HAPPY DAY • LET IT BE  
BRIDGE OVER TROUBLED WATER  
COME SATURDAY MORNING  
THE LONG AND WINDING ROAD  
(LOVE THEME FROM) ROMEO & JULIET  
CECILIA • A DREAM OF PEACE  
A SONG OF JOY

**RANWOOD**  
RECORDS, INC.

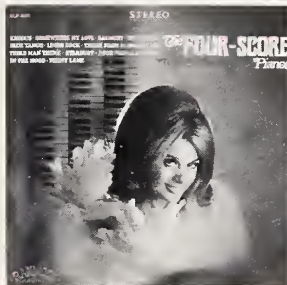

R8001 FOUR SCORE PIANOS

NOW A SINGLE, # 876 'A SONG OF JOY' BACKED BY 'A DREAM OF PEACE'  
FROM THE LATEST RANWOOD ALBUM HIT "A SONG OF JOY,"

RANWOOD RECORDS, INC., A SUBSIDIARY OF RANWOOD INTERNATIONAL, INC., 9034 SUNSET BLVD., LOS ANGELES, CALIF. 90069

## Chevy To Host 1st VIDCA Seminar On International Videorecordings

NEUILLY, FRANCE — Bernard Chevy, creator of the MIDEM and MIP TV is planning the first international symposium for videorecording specialists to be held at Cannes in next April. According to Chevy, the gathering is being arranged as a result of "consciousness of the needs implicit in the videorecording field for exchange and contact between social and professional circles." He added that he believes "an annual international meeting ground, geared to facilitating this contact, be instituted now."

The April meeting is set for the 17th to the 23rd in Cannes to coincide with the MIP TV gathering and aims to develop a symposium for specialists in all fields to voice their opinion on the future of the videocassette and videorecording as an informational, educational and pleasure tool. It will mark the creation of the VIDCA, International Market for Videocassette and Videorecord Programmes and Equipment.

Chevy, whose international meetings through MIDEM for music publishers and MIP TV regarding television programs, expressed three aims for the VIDCA: to provide a market for the sales and acquisition of software through the meetings of indie producers, suppliers and executives; to become a showcase for the latest

developments in hardware systems for professionals to compare performance and acquaint themselves with the advantages and costs of the systems best suited to their uses; and to provide a platform for open discussion of problems and applications of the videorecording materials.

## Norelco Reveals Three Players With Dual-Motor Tape Transport

An innovative dual-motor tape transport system, integrated circuitry, fuller sound reproduction and styling departures are featured in new Norelco cassette tape recorders announced last week by North American Philips Corp.

The four new recorder/players (to be unveiled at the Consumer Electronics

## N.A. Philips Expects 4-Channel Cassette Product By Year's End

NEW YORK — Matthew Dorenbosch, executive vice president of North American Philips, has stated that his firm is mounting a push for incorporation of four-channel stereo sound into the compact cassette system; and that N.A. Philips is already working on technology to make the 4-channel tapes

fully compatible with existing stereo and mono equipment.

Dorenbosch indicated last week that product to support the new technology is scheduled to be ready before the end of the year.

"Since introducing the cassette system into the U.S. nearly six years ago," he said, "the company has continued to introduce improvements for the system without obsoleting recorders and playback equipment presently in use. N.A. Philips has long sought a method for incorporating 4-channel sound without compromising commitments to consumers and to the trade. Technology has developed to a point where the objective of two-way compatibility can be achieved."

According to Dorenbosch, his firm plans to encourage industry-wide cooperation in establishing standards for such a system.

## Herr Is Gen Mgr With 3M Minicom

ST. PAUL, MINN. — Robert Herr, one of a team of 3M researchers who pioneered in the development of magnetic recording tape and equipment nearly a quarter of a century ago, has been appointed general manager of the company's Minicom division which markets a broad range of recording products.

Herr succeeds R. J. Gavin as general manager. Gavin, division vice president, will continue in that capacity, the company said, devoting his efforts to long range planning.

Herr joined 3M in 1946, after serving several years as a physicist with the Naval Ordnance Laboratories during World War II. As a member of the physics section of 3M's Central Research laboratories, he first concentrated on the development of magnetic recording tape. Subsequently, his research concentrated on electrical insulating materials, including tapes and resins. He also directed marketing research on a still wider range of efforts.

Minicom's product line includes the Wollensak family of audio visual and home entertainment tape recorders, 3M brand professional recorders electron beam recorders for transferring video signals to photographic film, precision instrumentation recorders and other instrumentation and video recording equipment and accessories.

## DeMeo joins BASF

BEDFORD, MASS. — Albert DeMeo has become manager of marketing administration of BASF Systems, Inc. by Thomas J. Dempsey, Director of Marketing of the Bedford-based company.

DeMeo joins BASF from the Transatron Electronic Sales Corp. in Wakefield, where he worked for 11 years in marketing positions. His most recent assignment was as manager of marketing services.

## Koss Raises ESP-7 Price

MILWAUKEE — Koss Electronics, Inc. has announced that effective immediately the consumer net price of ESP-7 electrostatic stereophones will increase to \$90. The former sale tag was \$79.

ESP-7 is a lightweight headset with coupling transformers and self-energized biasing circuitry externally located in the self-energizer unit. Introduced last year, it uses the same electrostatic principles of the ESP-6, the first self-energized electrostatic headphone.

Greg Cornehl, vice president of sales, said that no other price increases are contemplated by Koss in either the electrostatic or dynamic lines.

Show) include models 1570, 1530 and 1320 — with the advanced new two-motor tape transport that results in fewer moving parts providing greater reliability and durability — plus Model 1440, a miniature recorder and the first Norelco cassette machine to use integrated circuits.

Additionally, the three new recorders with the dual-motor system feature larger speakers for better mid-range reproduction and incorporate design and color innovations as well. Model 1570 also includes an FM-AM radio.

"The two-motor transport," according to home entertainment products up Paul Nelson, "provides the fastest and most dependable wind and rewind action so far available in cassette machines."

In the new engineering design, one motor is assigned to the recording/playback function and another furnishes the fast forward and rewind action. Eliminated are many of the complex step-up pulleys, belt arrangements and linkages required in single motor models to accomplish the three tape transport motions.

"The results," Nelson said, "are less wear and tear, hence greater reliability and longer life for the machine."

He noted that the three cassette recorders with the new tape transport design also have larger speakers, permitting better reproduction of the important middle frequencies for fuller enjoyment of the wide assortment of pre-recorded cassettes now available to the public.

The four new Norelco models all are equipped with dynamic microphones which feature remote start-stop switches. Each can play back through its own speaker or through an external speaker, has a lock that safeguards against accidental erasure of pre-recorded cassettes, handy push-button controls and is completely solid-state. Each is completely portable and operates vertically or horizontally.

## Ampex To Unveil Consumer Product

NEW YORK — The Ampex Corp. is unveiling their new products line at the upcoming Consumer Electronics Show. Included are the first component quality stereo multiplex receiver offered by the company, the ASR-100 (priced under \$250); a new home entertainment center combining a 4-speed automatic record changer with a cassette player/recorder and an AM/FM radio, MX-1000 (under \$490 inc. speakers); two open reel tape decks, the top of the line Model AX-300 (\$650) is the most advanced automatic stereo deck offered by Ampex, and the AX-50 priced lower at \$280; and four new models in the Ampex Micro Series of cassette tape recorders and players.

The new models are: Micro 54, a component stereo deck (under \$160); Micro 70, a portable stereo tape recorder with speakers (under \$190); Micro 44, an automobile stereo cassette player and FM stereo radio (under \$200); and the Micro 34, a monaural portable player/recorder and AM/FM radio (under \$120).

## DPC Markets Cassettes In 3 Prices/Qualities

BOSTON — Three new series of loaded blank cassettes are being displayed by the Dynasound division of Data Packaging Corporation at the Consumer Electronics Show.

A broad marketing campaign employing multiple distribution approaches and intensive promotion will be employed to introduce the Dynasound label, according to John Nelson, Data Packaging's director of marketing.

Dynasound began the production of the three series this spring in its Kennebunk, Me., plant, the largest manufacturing facility for cassettes and cartridges in the United States.

The three new series include: "Do-Your-Own-Thing", at popular-price; the "Performance," a medium-priced, quality cassette; and the "Classic" a top of the line, premium quality cassette.

All three cassette series carry a lifetime guarantee.

## Le-Bo Cuts Prices As Gov't Support

NEW YORK — Leslie Bokor and Les Dame have informed Cash Box that they will announce drastic price reductions on many of the items in Le-Bo's accessories line effective July 1. Both men made a point of stating that the price cuts are being instituted in line with the Government's desires for self-restraint in the areas of prices and wages.

In addition, Le-Bo Products will be introducing three additions to their line in the coming month. These will be specially designed cassette and tape home storage units with stylish furniture finishing to enhance the decor in which they are placed.

## Lear's 3rd 8-Tr Recorder

DETROIT — Lear Jet Stereo, Inc., has introduced its third stereo 8-track cartridge recorder. The newest model, H-350, is a deluxe deck with fast forward indexing, automatic stop at track end in the record mode, single and double track erase, and the capacity to record in either full stereo or monaural on all 8 individual tracks.

Product manager Robert Kilchenman stated that, "we refer to the model H-350 unofficially as the deluxe deck because of the advanced deluxe features incorporated, though it will carry a competitive suggested retail price of \$189.95. We will also be introducing a more conventional 8-track recorder deck in the near future at lower price."

Lear Jet's H-350 is finished in a walnut cabinet and comes with twin dynamic microphones.

## Audio Mag Offers Blank 8-Tr. Tapes

NEW YORK — Audio Magnetics Corp. is introducing a line of 8-track blank tape cartridges at the Consumer Electronics Show this week.

"We feel there will be a great response for blank 8-track cartridges to complement the prerecorded music market," said Ray Allen, sales vice president of Audio Mag.

The company will manufacture 36-minute and 72-minute blank tapes for marketing through regular distribution channels.

Audio also introduces two other new products at the New York show: including a Philips-style hard plastic box for 5-inch and 7-inch open reel tapes and a tent-carded package that allows blank cassettes to be rack merchandised.

## Mio & Map City Tapes For Ampex Duplicating

NEW YORK — Mio International Records Inc. has entered a long term tape duplicating agreement with Ampex Stereo Tapes. The pact provides AST with manufacturing and distributing rights to Mio's catalog in all tape configurations for the United States and Canada.

Negotiations were completed last week Mio president Marty Wilson and Don Hall, Ampex vice president and general manager of AST. Initial release of Mio product by AST is scheduled for September to feature twenty new albums, ten on the Mio International label and ten on Mio's recently announced economy label, the Universal Series 5000.

AST has also joined with Map City Records in a long term tape duplicating deal. The agreement gives AST world-wide manufacturing and distribution rights to the entire Map City line for all tape configurations.

Map City was formed by Frank Mell, president with partners Peter Anders and Vini Poncia. Anders and Poncia are also writers, producers and artists.



**GUESS WHO  
IS THE  
HEAVIEST GROUP  
TO COME  
OUT OF CANADA?**



**SANDS OF TIME**  
**"I'VE GOT A FEELING"**  
**NGR-11**

Distributed by Buddah Records  RECORDS

NATIONAL GENERAL RECORDS, 1041 NORTH FORMOSA AVENUE, HOLLYWOOD, CALIFORNIA 90046  
PHONE: 851-1234 ext.470

# New Additions To Radio Playlists

A broad view of the titles many of radio's key Top 40 stations added to their "Playlists" last week.

**WQAM — Miami**  
Signed Sealed—Stevie Wonder—Tamlam  
Ooh Child—5 Steps—Buddah  
Make It—Bread—Elektra  
Please Accept My Call—J.P. Robinson

**WABC — New York**  
Check Out—Impressions—Curton  
Close To You—Carpenters—A&M

**WTIX — New Orleans**  
Candida—Dawn—Beli  
Do You See My Love—Jr. Walker—Soul  
Baby This Is Something—McKinley Travis—Pride

**WLS — Chicago**  
Westbound #9—Flaming Embers—Hot Wax  
Why Can't I—Ronnie Dyson—Columbia  
Boys—Boys In The Band—Spring  
Close To You—Carpenters—A&M  
So Much Love—Faith Hope Charity—Maxwell

**KXOK — St. Louis**  
Same Old Feeling—PickettyWitch—Janus  
Superman—Ides Of March—Warner Bros.  
My Marie—Engelbert Humperdinck—Parrot  
Why Can't I—Ronnie Dyson—Columbia  
It's Your Life—Andy Kim—Steed  
She Cried—Lettermen—Capitol  
Que Sera Sera—Mary Hopkin—Apple

**WOKY — Milwaukee**  
Summertime Blues—The Who—Decca  
Monster Mash—Bobby Boris Pickett—Parrot  
Yellow River—Christie—Epic  
Everything A Man Could—Glen Campbell—Capitol  
Spill The Wine—Burdon & War—MGM

**WMAK — Nashville**  
Pick: It's Your Life—Andy Kim—Steed  
Westbound #9—Flaming Embers—Hot Wax  
Mississippi—John Philips—Dunhill  
Superman—Ides Of March—Warner Bros.

**WEAM — Washington, D. C.**  
The Witch—Rattles—Probe  
I Just Can't Help—B. J. Thomas—Scepter  
Close To You—Carpenters—A&M  
Take You Higher—Sly & Family Stone—Epic

**WMEX — Boston**  
Superman—Ides Of March—Warner Bros.  
So Much Love—Faith Hope Charity—Maxwell  
Crutches—Zager & Evans—RCA

**WQXI — Atlanta**  
Check Out—Impressions—Curton  
Make It With You—Bread—Elektra  
In The Summertime—Mungo Jerry—Janus  
Spill The Wine—Burdon & War—MGM  
Signed Sealed—Stevie Wonder—Tamlam  
I'll Be Right Here—Tyrone Davis—Dakar  
Why Can't I—Ronnie Dyson—Columbia

**WDGY — Minneapolis**  
Silver Bird—Mark Lindsay—Columbia  
Make It With You—Bread—Elektra  
So Much Love—Faith Hope Charity—Maxwell  
Lay A Little Lovin—Robin McNamara—Steed  
Spill The Wine—Burdon & War—MGM  
Pearl—Tommy Roe—ABC  
Signed Sealed—Stevie Wonder—Tamlam  
Overture—Assembled Multitude—Atlantic

**CKLW — Detroit**  
Signed Sealed—Stevie Wonder—Tamlam  
Steal Away—Johnny Taylor—Stax  
Are You Ready—Pac. Gas & Elec—Columbia  
Close To You—Carpenters—A&M  
Spill The Wine—Burdon & War—MGM

**WSAI — Cincinnati**  
Your Own Back Yard—Dion—Warner Bros.  
Lights Of Tuscon—Jim Campbell—Lori  
Why Can't I—Ronnie Dyson—Columbia  
Big Yellow Taxi—Neighborhood—Big Tree  
Signed Sealed—Stevie Wonder—Tamlam  
Teach—Crosby Stills Nash Young—Atlantic  
Summertime Blues—The Who—Decca  
Take You Higher—Sly & Family Stone—Liberty  
Mill Valley—Rita Abrams—Reprise

**WKBW — Buffalo**  
I Just Can't Help—B. J. Thomas—Scepter  
Mississippi Queen—Mountain—Windfall  
Superman—Ides Of March—Warner Bros.  
End Of The Road—Marvin Gaye—Tamlam  
If Johnny Comes Marching—Goliath—ABC  
Thrill Is Gone—Aretha Franklin—Atlantic  
War—Edwin Starr—Motown  
Higher & Higher—Canada Goose—Tonsil  
Pick: Why Can't I—Ronnie Dyson—Columbia

**WFIL — Philadelphia**  
Pick: Paper Mache—Dionne Warwick—Scepter  
Save The Country—5th Dimension—Bell  
Signed Sealed—Stevie Wonder—Tamlam  
Silver Bird—Mark Lindsay—Columbia  
Lay A Little Lovin—Robin McNamara—Steed  
Groovin With Mr. Bloo—Cool Heat—Forward  
LP: I Remember Summer Morning—Vanity Fare  
—Page One

**WRKO — Boston**  
You've Been My Inspiration—Main Ingredient—RCA  
Signed Sealed—Stevie Wonder—Tamlam  
LP: Only You Know And I Know—Dave Mason  
—Blue Thumb

**WMPS — Memphis**  
Pick: Paper Mache—Dionne Warwick—Scepter  
I Heard The Voice—Turley Richards—Warner Bros.  
Sly Slick Wicked—Lost Generation Brunswick  
Lets Make Each Other Happy—Illusions—Steed  
Gotta Get Away—Roy Gotfried—Spring  
Down By The River—Buddy Miles—Mercury  
Them Changes—Buddy Miles—Mercury  
Solitary Man—Neil Diamond—Bang  
Yellow River—Christie—Epic  
No Arms Can Hold You—Bobby Vinton—Epic  
One Day Of Your Life—Andy Williams—Columbia  
Monster Mash—Bobby Pickett—Parrot  
It Ain't Easy—Ron Davis—A&M  
LP: Feb. 1970 On Stage—Elvis Presley—RCA

**KQV — Pittsburg**  
Ohio—Crosby Stills Nash Young—Atlantic  
Groovin With Mr. Bloo—Mr. Bloo—DJM  
Silver Bird—Mark Lindsay—Columbia  
Go Back—Crabby Appeltin—Elektra  
Overture—Assembled Multitude—Atlantic  
War—Edwin Starr—Gordy  
Pearl—Tommy Roe—ABC  
Sly Slick Wicked—Lost Generation—Brunswick  
Why Can't I—Ronnie Dyson—Columbia

**WHB — Kansas City, Mo**  
Signed Sealed—Stevie Wonder—Tamlam  
No Arms Can Hold YOU—Bobby Vinton—Epic  
Tell It All Brother—Kenny Rogers—Reprise  
When We Get Married—Intruders—Gamble  
Groovy Situation—Gene Chandler—Mercury  
Give A Woman Love—Bobbi Martin—U.A.  
Make It With You—Bread—Elektra  
Charlie—Dickie Lee—RCA  
Pick: Destiny—Jose Feliciano—RCA  
Pick: Too Much Foolin Around—Tams—ABC

**KFRC — San Francisco**  
In The Summertime—Mungo Jerry—Janus  
Candida—Dawn—Beli  
Black Hands White Cotton—Caboose—Enterprise  
Same Old Feeling—Pickettywitch—Janus

**KIMN — Denver**  
Close To You—Carpenters—A&M  
I Just Can't Help—B. J. Thomas—Scepter  
Save The Country—5th Dimension—Bell  
Everything A Man—Glen Campbell—Capitol  
Tell It All Brother—Kenny Rogers—Reprise

**KXOA — Sacramento**  
Everything A Man—Glen Campbell—Capitol  
My Marie—Engelbert Humperdinck—Parrot

**KYNO — Fresno**  
Spill The Wine—Burdon & War—MGM  
Make It With You—Bread—Elektra  
Ball Of Confusion—Temptations—Gordy  
LP: Wigman—Bob Dylan—Columbia

**KGB — San Diego**  
Tell It All Brother—Kenny Rogers—Reprise  
Go Back—Crabby Appeltin—Elektra  
We're All Playing In The Same Band—Bert  
Summer—Eleuthera

**KYA — San Francisco**  
Spill The Wine—Burdon & War—MGM  
Freedom Blues—Little Richard—Reprise  
Make It With You—Bread—Elektra  
Roll Away The Stone—Leon Russell—Sheiter  
Mississippi Queen—Mountain—Windfall  
Lay A Little Lovin—Robin McNamara—Steed  
Morning Much Better—10 Wheel Drive—Polydor  
Paper Mache—Dionne Warwick—Scepter  
Boys—Boys In The Band—Spring

**KRLA — Pasadena**  
Lay A Little Lovin—Robin McNamara—Steed  
Tell It All Brother—Kenny Rogers—Reprise  
Sign Sealed—Stevie Wonder—Tamlam  
Boys—Boys In The Band—Spring  
Paper Mache—Dionne Warwick—Scepter

**KHJ — Hollywood**  
Black Hands White Cotton—Caboose—Enterprise  
Signed Sealed—Stevie Wonder—Tamlam  
Make It With You—Bread—Elektra

**KILT — Houston**  
Pick: Big Yellow Taxi—Neighborhood—Big Tree  
Can't Leave Your Love—Clarence Carter—Atlantic  
Boys—Boys In The Band—Spring  
Paper Mache—Dionne Warwick—Scepter  
It Ain't Easy—Ron Davis—A&M

**WCAO — Baltimore**  
Do You See My Love—Jr. Walker—Soul  
Tell It All Brother—Kenny Rogers—Reprise  
Yellow River—Christie—Epic  
You've Been My Inspiration—Main Ingredient  
—RCA

When We Get Married—Intruders—Gamble  
Mississippi—John Philips—Dunhill  
Song Of Mash—Al DeLory—Capitol  
Band Of Gold—Freda Payne—Invictus

**WKNR — Detroit**  
Your Own Back Yard—Dion—Warner Bros.  
Big Yellow Taxi—Neighborhood—Big Tree  
Tell It All Brother—Kenny Rogers—Reprise  
War—Edwin Starr—Gordy  
Dat Ding—Pipkins—Capitol

**WIBG — Philadelphia**  
Pick: Groovin With Mr. Bloo—Cool Heat—Forward  
Silver Bird—Mark Lindsay—Columbia  
Signed Sealed—Stevie Wonder—Tamlam

**WAYS — Charlotte**  
Do You See My Love—Jr. Walker—Soul  
Check Out—Impressions—Curton  
Stealing In The Name Of The Lord—Paul Kelly  
—Happy Tiger  
Long Lonely Nights—The Dells—Cadet  
Sly Slick Wicked—Lost Generation—Brunswick  
Westbound #9—Flaming Embers—Hot Wax  
Ooh Child—5 Steps—Buddah  
End Of The Road—Marvin Gaye—Tamlam  
Spill It With You—Bread—Elektra

## HAPPENING NOW!

**Jimmy Jones**  
Soul Brother #2

**"SAY, AMEN,  
BROTHER"**

Judy 9014

**JODY RECORDS**

2226 McDonald Ave.  
Brooklyn, N.Y. 11223

# SCENES '70'

REGISTRATION APPLICATION FOR THE FIRST  
ANNUAL INTERNATIONAL RADIO-MUSIC CONFERENCE  
AT NIAGARA FALLS ONTARIO, BROCK HOTEL  
JULY 16, 17, 18

NAME \_\_\_\_\_

POSITION \_\_\_\_\_

COMPANY \_\_\_\_\_

ADDRESS \_\_\_\_\_

CITY \_\_\_\_\_

STATE \_\_\_\_\_ ZIP \_\_\_\_\_

A Registration Fee of \$75.00 per person must accompany this application. This admits you to the Cocktail Party, Friday and Saturday Breakfast and Luncheons, Saturday Banquet, also all Seminars and Mini Sessions. Additional Breakfast Tickets are \$2.50. Additional Luncheon Tickets are \$5.00. Additional Banquet Tickets are \$15.00

RATES:	SINGLES	DOUBLES	CHILDREN
START AT—TO:	18:50—20.00	24.50—28.00	No Charge

For Information on Rates and the availabilities of Two Room and Three Room Suites for use as Hospitality Suites—Please Contact Mickey.

'NIAGARA'

To facilitate your Pre-Registration and Hotel Reservations, please return this form to:

**SCENES '70'**  
BEHIND THE SCENES  
832 RAND BUILDING  
BUFFALO, NEW YORK 14203

## Hotels, Motels Honor BMI's 25th Anniversary Tie-in

NEW YORK — BMI was honored for 25 years of allied membership in the American Hotel and Motel Association, which represents 7,500 hotels and

motels in the United States and abroad.

The Association's president, Herbert C. Blunck, presented a 25-year plaque to BMI vice president George Gabriel at a recent luncheon at the New York Hilton.

More than 350 leading firms providing products or services to the American lodging industry are allied members of the Association.

When a new release comes out everybody jumps, yells, screams, praises, shouts and generally raises hell.

We're not!

We just want to tell you that Jeff Barry Productions has just produced a new single.

"Funky Hunk A' Guy" AMPEX (X11007)  
sung by Susan Morse and  
distributed by Ampex Records.

The record will tell you the rest.

**AMPEX**  
RECORDS

## Picks of the Week

**DIONNE WARWICK** (Scepter 12285)

**Paper Mache** (2:56) (Blue Seas/Jac, ASCAP — Bacharach, David)

One of the rare Bacharach/David comments on the world (the last was "Windows of the World") brings a refreshing change from love and loss to both the team and Miss Warwick. Scintillating arrangements, as usual, and the sparkle of performance and production assure across the board exposure. No flip info.

**THE WHO** (Decca 32708)

**Summertime Blues** (3:22) (Rumbalero/Elvis Presley/Viva, BMI — Cochran)

Twice a hit, the "Summertime Blues" comes coasting back in yet another explosive time round. Latest is the Who's from their "Live At Leeds" LP with a ready-made reaction tailored by their early airplay and on stage presentations. Cochran and Cheer, move over. Flip: "Heaven & Hell" (3:31) (Track, BMI — Entwistle)

**NEIL DIAMOND** (Bang 578)

**Solitary Man** (2:28) (Tallyrand, BMI — Diamond)

There's no gem like an old Diamond polished up for new viewing as is the case with this revived side. Attractive arrangements, teen and young adult oriented lyrics and the vocal performance fuse into a shining top forty jewel. Flip: "The Time is Now" (3:10) (Same credits.)

**JR. WALKER & THE ALL STARS** (Soul 35073)

**Do You See My Love (for You Growing)** (3:14) (Jobete, BMI — Beavers, Bristol)

Tension is built into the opening of this new vocal side from Jr. Walker, and the listener magnetism is maintained by a straining sax wail and feverish solo/chorus track. Sensational blues and teen-forty workout. Flip: "Groove & Move" (2:53) (Jobete, BMI — Bristol, DeWalt, Hollis)

**ISLEY BROTHERS** (T-Neck 921)

**Girls Will Be Girls, Boys Will Be Boys** (2:30) (Triple 3, BMI — R,O & R Isley)

An astonishing changeabout from the Isleys shakes them out of the rhythmic carbon copying rut and sets them on a fresh new track. Team relies move heavily on vocal fireworks to cook up the excitement that will break this side R&B. Flip: No info.

**EDDIE FLOYD** (Stax 0072)

**My Girl** (3:19) (Jobete, BMI — Robinson, White)

Jobete's major standard, "My Girl" takes kindly to a readjustment for Memphis sound in this new Eddie Floyd single. The outstanding material and Floyd's woman's-man reputation should start the action flogging from R&B to top forty fronts. Flip: No info.

**ANDY KIM** (Steed 727)

**It's Your Life** (2:45) (Unart/Joachim, BMI — Barry, Kim)

Two of the major forces behind the Archies' scenes, Jeff Barry and Andy Kim turn some of their teeny-sould material into a likely hit outing for Kim himself. Fine rhythmic force and a power-packed production should excite top forty showings. Flip: "To Be Continued" (3:17) (Same credits)

**BILL DEAL & THE RHONDELS** (Heritage 824)

**Hey Bulldog** (2:27) (Maclen, BMI — Lennon, McCartney)

Bill Deal and companions cast off their rough-hewn style with their last single; now they enter a new phase with a cleaner production sound that adds new dimension to the team's sound. Working with a lesser Lennon-McCartney song, the Rhondels come up with a winning teen entry. Flip: No info.

**MAC DAVIS** (Columbia 45192)

**I'll Paint You A Song** (3:24) (Ensign, BMI — Davis)

An outstanding Mac Davis composition for the score of "Norwood," this ballad presents the artist in a dramatic light bound to please fans won by his "Whoever Finds This." Extremely fine side for all formats, teen and country to easy listening. Flip: "Closest I Ever Came" (2:54) (Metric/Low-Twi, BMI — Davis)

**BOBBY GOLDSBORO** (United Artists 50696)

**It's Gonna Change** (2:40) (Detail, BMI — Goldsboro)

Lyrics with the personal touch that made "Honey" a million-seller for this artist, and addition of a more rhythmic undercurrent give B.G. another strong side for total exposure. Expect the rhythm track to catch top forty ears and the lyric to appeal to older listening audiences. Flip: "Down on the Bayou" (2:55) (Same credits)

**THE GENTRYS** (Sun 1118)

**He'll Never Love You** (1:59) (no credits available)

"Cinnamon Girl" having just about wended its course, the Gentrys come back with a softer ballad entry to reenter the chart running. Enticing work with young teen listeners the target group should maintain the group's sales drive. Flip: "I Hate to See You Go" (1:15)

**THE BEACH BOYS** (Brother 0929)

**Slip On Through** (2:14) (Daywin/Brother, BMI — D. Wilson)

Radical Shift in style leaves one wondering about the Beach Boys' name tag on this new side. Group's power is channeled into a more contemporary and less distinctively BB mannerism that should ignite sales even more brightly than their first Reprise venture. Flip: "This Whole World" (2:00) (Brother, BMI — B. Wilson) More of a transitional piece, this side deserves extra consideration as the plug track.

**ESTHER PHILLIPS** (Atlantic 19388)

**Set Me Free** (3:32) (Tree, BMI — Putman, Jr.)

Familiar ballad is refashioned by Esther Phillips to become the side that should earn her the recognition she has long deserved. Her delivery carries just an extra bit of electrical charge to sear listener interest on blues and top forty fronts. Flip: "Brand New Day" (4:15) (Van-Jan, ASCAP — Morrison)

**BURL IVES** (Cyclone 75014)

**One More Time Billy Brown** (2:59) (Martin Cooper, ASCAP — Cooper)

Ever since the surprise ending of "Honey," there is a characteristic interest-locking quality in certain ballads. This Burl Ives performance also telegraphs its closing twist, but follows through one step further in an intriguing across-the-board offering. Flip: "Tied Down Here at Home" (2:20) (J.L.S., ASCAP — Robertson)

## Newcomer Picks

**BERT SOMMER** (Eleuthera 470)

**We're All Playing in the Same Band** (3:17) (Luvlin/Magdalena, BMI — Sommer)

A noisemaker with Capitol, live appearances and his "Hair" reputation have laid solid groundwork in front for Bert Sommer's new single. Side is an intriguing steel-band touched rock ballad that carries sound magnetism for top forty consideration and even MOR thought as a pace-changer. Flip: "It's A Beautiful Day" (3:00) (Same credits)

## Choice Programming

Choice Programming selections are singles which, in the opinion of our reviewing staff, are deserving of special programmer consideration.

**LOU RAWLS** (Capitol 2856)

**Bring It On Home To Me** (2:59) (Kags, BMI — Cooke)

Though this Sam Cooke song has been done countless times, Lou Rawls brings an originality and freshness to "Bring It On Home" that could relight its chart activity yet again. Flip: "Can You Dig It/Take Me For What I Am" (3:14) (Lou Rawls/Kags, BMI — Rawls, Cooke)

**THE SOULFUL DYNAMICS** (Buddah 173)

**Mademoiselle Ninette** (2:28) (Multi-tone, ASCAP — Hildebrandt, Winhauer)

European variant on the bubblegum technique has earned a gold record in Germany and now could win top forty favor in the U.S. Flip: "Monkey" (3:29) (Multiton, ASCAP — Arr: Baierle)

**THE J.B.'s** (King 6317)

**The Grunt (Pt. 1)** (2:47) (Golo, BMI — Brown, J.B.'s)

Searing instrumental powered by a sax spotlight and rhythmic fuel for R&B and possible top forty breakouts. Flip: "Pt. 2" (2:10) (Same credits)

**STRAWBERRY ALARM CLOCK** (Uni 55241)

**Girl From The City** (2:30) (Fitzpatrick, ASCAP — Marshall)

From the "Beyond The Valley Of The Dolls" track comes this CSN&Y-like pop ballad side. Top forty fare. Flip: "Three" (2:30) (Fitzpatrick, ASCAP — King, Freeman)

**AL KOOPER** (Columbia 45179)

**Brand New Day** (3:14) (Unart, BMI — Kooper)

Strange outing has the ready-made familiarity afforded by use in "The Landlord." Pretty on its own, the song could score AM & FM play. Flip: "Love Theme From 'The Landlord'" (3:13) (Unart, BMI — Kooper)

**SAVAGE GRACE** (Reprise 0924)

**Come On Down** (3:30) (Cannibal/WB-Tamerlane, BMI — Koss)

Powerhouse instrumental work and a good vocal performance could ignite this from-the-LP selection for Savage Grace. Flip: Longer (4:19) version.

**JAMES STEWART & HENRY FONDA** (NGC 007)

**Rolling Stone** (3:00) (Montage, ASCAP — Scharf, Kasha, Hirschhorn)

Totally off-the-wall ballad in the "Wandrin' Star" vein, but with spoken comments that just could spark enough play to prod hit sales. Flip: "Theme From 'The Cheyenne Social Club'" (2:20) (Montage, ASCAP — Scharf)

**THE SPECTRAS** (Project Three 1384)

**And You Love Her** (2:59) (Record/Lisa Sue; ASCAP — Hest)

Attractively styled ballad which has both teen and adult power on this new side from the Spectras. Flip: "Happy Life Together" (2:53) (Record/Music, Music, Music, ASCAP — Jordan)

**JAYAR** (Sanfris 52)

**Get Yourself Together** (2:23) (Snow White, ASCAP — Dulka, Marshall)

Sparkling teen side with a summery drive and brass additive for impact. Could find top forty receptions. Flip: "Wanderers East, Wanderers West" (2:50) (Famous, ASCAP — Bernstein, Millrose)

**TEN WHEEL DRIVE** (Polydor 14037)

**Morning Much Better** (2:38) (Scheffrin-Zager/Noma, BMI — Zager, Scheffrin)

Track has been spotted as an FM showpiece from the latest Ten Wheel Drive LP. Could pick up added top forty interest. Flip: "Stay With Me" (3:35) (Ragmar/Crenshaw, BMI — Ragovoy, Weiss)

**DEEP PURPLE** (Warner Bros. 7405)

**Black Night** (2:58) (HEC, ?? — Blackmore, Gillan, Glover, Lord, Paice)

Thundering side with a powerhouse rhythm track to inspire pop-forty as well as FM coverage on the new Deep Purple outing. Flip: "Into The Fire" (3:35) (Same credits)

**NEW COLONY SIX** (Mercury 73093)

**Close Your Eyes Little Girl** (2:49) (New Colony, BMI — Rice, McBride)

Yet another satiny ballad from the New Colony Six presents their soft-sell material with a luster that could capture across the board notice. Flip: No info.

**THE JERRY HAHN BROTHERHOOD** (Columbia 45195)

**Captain Bobby Stout** (2:59) (Sharp — Gannon, ASCAP — Tietgen)

Work gang blues with an amplified instrumental support could make this unusual side a powerful FM entry with top forty prospects. Flip: No info.

**MAVIS STAPLES** (Volt 4044)

**I Have Learned To Do Without You** (4:09) (Groovesville, BMI — Barnes, Jordon, Davis)

That voice, that voice and a standout ballad could make this the track that brings in R&B hit showings. Flip: "Since I Fell For You" (3:34) (Warner Bros., ASCAP — Johnson)

**MAN & WIFE** (Epic 10633)

**Who Shot The Piper Man** (2:52) (Blackwood, BMI — Ford)

English import with a teasing sound that could just make this a long-shot that comes home on the top forty track. Novel teen offering. Flip: "you Got Soul" (3:24) (Blackwood, BMI — Ford)

**ZENDICK** (Pslhrtz 100)

**Is There No Peace** (3:06) (Into Now, BMI — Kossy)

Instrumental charged rock side with the power to captivate top forty and FM audience. Flip: "Aesop" (2:50) (Into Now, BMI — Brower)

**GENTLEHOOD** (Zabad 2525)

**Gazebo** (2:44) (Zodian, BMI — Feigel)

Impressive new act debuts with a softened rock ballad that could attract consideration on both FM and top forty-AM levels. Flip: No info. Zabad is distributed by Musicor.

**RICK McCLELLAN** (Quad 105)

**Redheaded Woman** (3:06) (Stellar, BMI — McClellan)

Medium paced side that makes up in power what it lacks in speed. Could see enough teen discotheque interest to spur top forty action. Flip: "2:30 In The Morning" (Same credits)

**MEL WYNN TREND** (Mercury 73073)

**That's When The World Really Began** (2:28) (Three Bridges/Cypher, ASCAP — Wynn)

Brass intro promises attractive teen material that follows. Fulfiling, this the Mel Wynn Trend could crack top forty playlists. Flip: "Hit Record" (2:29) (Same credits)

## AF Adds 9 More Full-Line Dist.

NEW YORK — Herman D. Gimbel, president of Audio Fidelity Records, reports the appointment of nine new full line distributors, bringing the company's total number of distributors to 26.

The distributors, each of whom will stock the full line of Audio Fidelity records in depth are: Temple Sales, Inc., Boston, Mass., Globe Distributors, Inc., Hartford, Conn., Midwest, Ltd., Cleveland, Ohio and Pittsburgh, Pa., Choice Distributors Corp., Kansas City, Mo., Certron Corp., Phoenix, Arizona, Fidelity Northwest, Seattle, Washington, MacDonald Sales Corp., New Orleans, La., Pan American Distributors, Denver, Colorado and Music Sales of Florida, Miami, Fla.

"... we anticipate a complete line-up of 30 to fully blanket the entire country from coast-to-coast with the finest distributor-network in the record industry," noted Mitch Manning, national sales manager for AF, who recently returned from an extensive field trip covering the east, south and midwest.

"Each of the Audio Fidelity distributors will carry the complete line of our products in every market and will be set up to give immediate sales and promotional aid to all dealers in their area," he also stated.

At the same time, Gimbel revealed that the company's first two albums in its recently released Ambience Sound Series have set new sales figures and will probably be among the best selling LP's ever produced by Audio Fidelity. A major promo program is now being planned for this Series.

## Grand Funk Summer Tour

NEW YORK — Capitol's Grand Funk Railroad initiates a two month summer tour June 19-20 at the Capitol Theatre in Portchester, N.Y. The string of concert dates is guaranteed to gross a minimum of \$275,000 for the group according to manager Terry Knight.

The complete schedule is, after the initial date, June 21, Dinner Key Aud., Miami; 22, Roberts Sports Arena, Sarasota; 23, Jacksonville Coliseum; 24, Civic Aud., West Palm Beach; 25, Sports Center, Orlando; 26, Hampton Roads Coliseum, Virginia; July 10, Aragon Ballroom, Chicago; 12, Rayne Stadium, Youngstown; 17, Randalls Island, N.Y.C.; 24, Stonybrook College, L.I.; 25, Convention Hall, Asbury Park, N.J.; 28, Paramount Theatre, Wilkes Barre, Pa.; 31, Fillmore East, N.Y.C.

August 1, Fillmore East; 2, Powder Hill Ski Area, Middlefield, Conn.; Circuit Quebec, St. Croix, Quebec City; 15, Mississippi River Festival Site, Edwardsville, Ill.; 19, Memorial Stadium, Charlotte, N.C.

## Artist Haven At TEMPI Studios

NEW YORK — Producer Rachel Elkind and performer Walter Carlos, responsible for the smash "Switched-On-Bach" LP on Columbia and their current hit, "The Well-Tempered Synthesizer," will be recording new artists under a unique policy.

They are building a 16-track Dolby State of The Art studio called TEMPI in their 4-story, West 87th Street, brownstone that will allow the artist to perform under "ideal conditions." And that means mentally as well as physically" said Rachel Elkind.

"The performer will not be pushed to end a session because of time," she said. "Nor will he be deprived of having an important say in what material is to be released. Nor will we hang onto an artist's contract if we feel we're not helping him".

"The philosophy of TEMPI" she added "will be to create an atmosphere of family. Performers signed to TEMPI can share our home and our dinner table anytime they please."

"Frankly," said Rachel, "Walter and I intend to make TEMPI as famous for the conditions we offer an artist as the product we put out".

## 'New' Barnaby Makes Good

HOLLYWOOD — Managers are never really happy with the treatment they get from most disk companies, but Barnaby Records is out to change all that. Alan Bernard, after years of fighting with disk firms to get the best possible care for his artists, now finds himself on the other side of the fence as head of Andy Williams' Barnaby Records operation, and his philosophy is "I'd like to run this company as if I had an act on the label."

Bernard, who's been Williams' manager for the last ten years, was not involved with Barnaby when it first started over a year ago, but was called in recently to give the Columbia-distributed label some new direction. First single from Barnaby under the new management was "Everything Is Beautiful," which gave the label its first hit and Ray Stevens his first #1 disk since "Ahab The Arab." Stevens, a former management client of Bernard, was also set as summer replacement for the Andy Williams TV'er, and preliminary indications show that the series will be a heavy success.

"We can't guarantee every artists we sign will get the same kind of TV exposure," said Bernard, "but we are capable of making efficient use of TV to help an artist bring home a 'happening' record and then help build his career." Bernard, who guided Lloyd Thaxton from a local show to the first important syndicated music show, and has also helped the careers of Roger Miller, Jack Jones, Bob Newheart and many others, seems to know whereof he speaks.

"We don't want to manage the acts we sign, but we feel that our experience in the business helps us advise on important career decisions," Bernard added.

### Cadence Reissues

Under Bernard, Barnaby has been busy signing new acts and production deals. Several new artists will be introduced at the upcoming Columbia convention, including Jimmy Buffett, whose "Down To Earth" al-

bum was produced by Bobby Russell and Buzz Cason; and Mayberry R.F.D.'s Ken Berry. Also recording for the label are Peyton Hoag, being produced by Ray Stevens; and the Crickets.

The label has already started re-issuing material from the old Cadence catalog, with a two-record specially priced set of "The Everly Brothers Greatest Hits" being the first LP. In addition, a flock of singles by such artists as the Chordettes, Julius LaRosa, Johnny Ray, Archie Bleyer and others are being issued as part of the Epic "Memory Lane" series. Bernard is currently contemplating release of some of the jazz album in the Candid catalog.

## ATI: Host Of New British Signings

NEW YORK — ATI Public Relations has signed twenty-one British acts for exclusive U.S. representation. They are: Savoy Brown, Small Faces, Rod Stewart, Brian Auger & the Trinity, Family, Nice, Colosseum, Rare Bird, Chicken Shack, Heavy Jelly, Andwella's Dream, Spencer Davis, Black Sabbath, Move, Trader Horne, Van der Graaf Generator, Writing On The Wall, Christine Perfect, Steam Hammer, Jack Bruce, and May Blitz.

Jeff Franklin, chairman of the board of ATI commented that much of the credit for the signings goes to Ira Blacker, who will be coordinating the bookings of the groups. ATI has also completed negotiations for Alice Cooper, Steam, Freddie King, and Tom Rush to tour the U.K. this summer.



**EVERYTHING IS STEVENS** — Singer Ray Stevens, whose Barnaby single "Everything Is Beautiful" has been a smash, will be taking over as Andy Williams' summer TV replacement. An advance screening and press reception was held on both coasts prior to the June 20th premier of "The Ray Stevens Show." Shown greeting Ray at the East Coast reception in N.Y. are Columbia/Epic execs. (from l.) Jon Waxman, associate product mgr., Don Ellis, director of merchandising, Lee Trippett, manager of merchandising services, Nick Barna, salesman, Stevens, Irv Medway, sales mgr. and Mike Kagan, director of nat'l. promo.

### MYRL RECORD CO.

AND

### IRENE MUSIC CO.

has master tapes for lease,  
Country, Soul, And Rock.  
Also songs for lease.

Mailing address. P.O. Box 857  
Ferriday LA. 71334  
(318) 757-3432

## Becker/Fagen To ASCAP

NEW YORK — Composer/artists Walter Becker and Donald Fagen have signed an exclusive ASCAP songwriter's contract. Becker and Fagen wrote the soundtrack music for a new wave film, "You've Got To Walk It Like You Talk It." The score was produced by Kenny Vance for JATA Enterprises. The music is being co-published with JATA's High Life Music, Inc., by the Peer Southern Organization.

Becker and Fagen arranged "Capture The Moment" and "Tricia Tell Your Daddy," both by Jay and The Americans, the new Ersel Hickey single "Self Made Man" b/w "Honeyboy" and "Simple Song" by the Maximum Security.

Donald Fagen, who co-wrote the score, appears in "Walk It." Upon completion of the soundtrack, Becker and Fagen began recording their debut album, being produced by Kenny Vance.

## RCA Records believes in him.



**It's your  
vehicle, baby.**

the ides of march

**VEHICLE**



**Ride it.**



# TOP 100 Albums

BOTTOM NO. INDICATES 8 AND 4 TRACK AND CASSETTE

July 4, 1970

1	LET IT BE	BEATLES (Red Apple 34001) (8XT 34001) (4XT 34001)	1	34	THE WORLD OF JOHNNY CASH	(Columbia GP 29) (18 BO 0906) (16 BO 0906)	35	68	BLOOD, SWEAT & TEARS	(Columbia CS 9720) (COL 18 10 0552) (COL 14 10 0552) (16 10 0552)	69
2	WOODSTOCK	ORIGINAL SOUNDTRACK (Cotillion SD-3-500) (TP 3-500) (CS 3-500)	3	35	CRICKLEWOOD GREEN	TEN YEARS AFTER (Deram DES 18038) (M 77838) (M 77638)	33	69	HELLO, I'M JOHNNY CASH	(Columbia KCS 9943) (18 10 0826) (14 10 0826) (16 10 0826)	53
3	McCARTNEY	PAUL McCARTNEY (Apple STAO 3363) (8XT 3363) (4XT 3363)	2	36	LADIES OF THE CANYON	JONI MITCHELL (Reprise RS 6376) (8RM 6376) (CRX 6376)	37	70	THE JIM NABORS HOUR	(Columbia CS 1020) (18 10 1020) (16 10 1020)	—
4	LIVE AT LEEDS	THE WHO (Decca DL 79175) (6-9175) (73-9175)	4	37	LONG LONESOME HIGHWAY	MICHAEL PARKS (MGM SE-4662)	32	71	SOMETHING'S BURNING	KENNY ROGERS & THE FIRST EDITION (Reprise RS 6385) (8RM 6385) (CRX 6385)	55
5	CHICAGO	(Columbia KGP 24) (18 BO 0858) (16 BO 1858)	6	38	SANTANA	(Columbia CS 9781) (18 10 0692) (16 10 0692)	40	72	RAINDROPS KEEP FALLIN' ON MY HEAD	ANDY WILLIAMS (Columbia CS 9896) (18 10 0736) (16 10 0736)	84
6	DEJA VU	CROSBY, STILLS, NASH & YOUNG (Atlantic SD 7200) (TP 7200) (CS 7200)	5	40	HAIR	B. J. THOMAS (Scepter SPS 580)	31	73	WHAT LOVE HAS JOINED TOGETHER	SMOKEY ROBINSON & THE MIRACLES (Tamla TS 301) (T8 1301) (T75 301)	79
7	THE FIFTH DIMENSION GREATEST HITS	(Soul City SCS 33900)	7	41	ABBEY ROAD	BEATLES (Apple SO 383) (8XT 383) (4XT 383)	41	74	HOME	PROCOL HARUM (A&M SP 4261) (8T 4261) (CS 4261)	—
8	ABC	JACKSON 5 (Motown MS 709) (M8 1709) (M75 709)	9	42	JOE COCKER	(A&M SP 4224) (8T 4224) (4T 4224) (CS 4224)	39	75	VIVA TIRADO	EL CHICANO (Kapp KS 3532) (18 10 0736) (16 10 0736)	85
9	CANDLES IN THE RAIN	MELANIE (Buddah BDS 5060) (85061) (55061)	13	43	FIREWORKS	JOSE FELICIANO (RCA LSP 4370) (P8S 1595) (PK 1595)	43	76	GRAND FUNK	GRAND FUNK RAILROAD (Capitol SKAO 406) (8XT 406) (4XT 406)	64
10	BRIDGE OVER TROUBLED WATER	SIMON & GARFUNKEL (Columbia KCS 9914) (18 10 0750) (14 10 0750) (16 10 0750)	10	44	PSYCHEDELIC SHACK	TEMPTATIONS (Gordy 947) (G8 1947) (G75 947)	45	77	BETTER TIMES ARE COMING	RHINOCEROS (Elektra EKS 74075) (M8 4075)	—
11	HENDRIX BAND OF GYPSYS	JIMI HENDRIX (Capitol STAO 472) (8XT 472) (4XT 472)	8	45	ERIC BURDON DECLARES WAR	(MGM SE 4663)	50	78	REFLECTIONS OF MY LIFE	MARMALADE (London PS 575) (72171) (57171)	89
12	ON STAGE—FEBRUARY, 1970	ELVIS PRESLEY (RCA LSP 4362) (P8S 1594) (PK 1594)	19	46	CLOSER TO HOME	GRAND FUNK (Capitol SKAO 471) (8XT 471) (4XT 471)	—	79	GETTING TO THIS	BLODWYN PIG (A&M SP 4243) (8T 4243) (4T 4243) (CS 4243)	83
13	STEPPENWOLF LIVE	(Dunhill DSD 50075)	16	47	POCO	(Epic BN 26522) (N18 10258) (N16 10258)	58	80	LET'S BE FRIENDS	ELVIS PRESLEY (Camdon CAS 2408)	72
14	AMERICAN WOMAN	THE GUESS WHO (RCA LPS 4266) (P8S 1518) (PK 1518)	12	48	OH HAPPY DAY	GLEN CAMPBELL (Capitol SW 443) (8XT 443) (4XT 443)	38	81	JUST PLAIN CHARLEY	CHARLEY PRIDE (RCA LSP 4290) (P8S 1536) (PK 1536)	77
15	GET READY	RARE EARTH (Rare Earth RS 507) (R8 1507) (R75 507)	17	49	SWEET BABY JAMES	JAMES TAYLOR (Warner Bros. /7 Arts WS 1843) (8WM 1843) (CWX 1843)	56	82	MARRYING MAIDEN	BEAUTIFUL DAY (Columbia CS 1058) (18 10 1058) (16 10 1058)	—
16	IT AIN'T EASY	THREE DOG NIGHT (Dunhill 50078)	11	50	GASOLINE ALLEY	ROD STEWART (Mercury SR 6 1264)	60	83	IN-A-GADDA-DA-VIDA	IRON BUTTERFLY (Atco 2051) (2501) (X 52501)	82
17	THE ISAAC HAYES MOVEMENT	(Enterprise ENS 1010) (EN8 1010) (ENC 1010)	18	51	PORTRAIT	5TH DIMENSION (Bell 6045) (M8 6045) (M5 6045)	44	84	LENA & GABOR	LENA HORNE & GABOR SZABA (Skye SK 15A)	88
18	TOM	TOM JONES (Parrot XPAS 71037) (M 79837) (M 79637)	14	52	WE MADE IT HAPPEN	ENGELBERT HUMPERDINCK (Parrot XPAS 71038) (M 79838) (M 79638)	—	85	FIRST STEP	SMALL FACES (Warner Bros. WS 1851) (8WM 1851) (CWX 1851)	92
19	MOUNTAIN CLIMBING	MOUNTAIN & FELIX PAPPALARDI (Windfall W-4501)	20	53	JOHN B. SEBASTIAN	(MGM SE 4654) (Reprise RS 6379) (8RM 6379) (CRX 6379)	49	86	DIANA ROSS PRESENTS THE JACKSON 5	(Motown MS 700) (M8 1700) (M75 700)	73
20	HEY JUDE	BEATLES (Apple SW 385) (8XT 385) (4XT 385)	21	54	RAINDROPS KEEP FALLIN' ON MY HEAD	JOHNNY MATHIS (Columbia CS 1005) (18 10 1005) (16 10 1005)	59	87	FRIJID PINK	(Parrot PAS 71033) (79833) (79633)	76
21	BENEFIT	JETHRO TULL (Reprise RS 6400) (8RM 6400) (CRX 6400)	22	55	AIR FORCE	GINGER BAKER (Atco SD 2-703) (TP2-703) (CS2-703)	42	88	OPEN	BLUES IMAGE (Atco 33-317) (TP 33-317) (CS 33-317)	93
22	LIVE CREAM	(Atco SD 33-328) (TP 33-328) (CS 33-328)	15	56	BITCHES BREW	MILES DAVIS (Columbia GP 26) (18 BO 0908)	57	89	GETTING TOGETHER	FERRANTE & TEICHER (United Artists UAS 5501)	—
23	THE BEST OF PETER, PAUL & MARY	(Warner Bros. BS 2552) (8WM 2552) (CWX 2552)	30	57	EVERYTHING IS BEAUTIFUL	RAY STEVENS (Barnaby 212 35005) (Z 18 35005) (Z 16 35005)	62	90	JOHN PHILLIPS	(Dunhill DS 50077)	96
24	STILL WATERS RUN DEEP	FOUR TOPS (Motown MS 704) (M8 1704) (M5 704)	28	58	MORRISON HOTEL	DOORS (Elektra EKS 75007) (M8 5007)	46	91	WHICH WAY YOU GOIN' BILLY	THE POPPY FAMILY (London PS 574) (72172) (57172)	98
25	THE DEVIL MADE ME BUY THIS DRESS	FLIP WILSON (Little David LD 1000)	25	59	GARY PUCKETT & THE UNION GAPS GREATEST HITS	(Columbia CS 1042) (18 10 1042) (16 10 1042)	87	92	DEEP PURPLE AND THE ROYAL PHILHARMONIC	(Warner Bros. WS 1860)	90
26	IRON BUTTERFLY LIVE	(Atco SD 318) (TP 318) (CS 318)	23	60	GREATEST HITS	SERGIO MENDES & BRASIL 66 (A&M SP 4252) (8T 4252) (CS 4252)	65	93	ALONE TOGETHER	DAVE MASON (Blue Thumb BTS 19)	—
27	HERE COMES BOBBY	BOBBY SHERMAN (Metromedia 1028) (890-1028) (590-1028)	24	61	THE AGE OF AQUARIUS	5TH DIMENSION (Soul City SCS 92005) (8951) (4951) (C-951)	51	94	IN THE BEGINNING (CIRCA 1960)	THE BEATLES FEATURING TONY SHERIDAN (Polydor 4504)	95
28	MUSIC FROM "BUTCH CASSIDY AND THE SUNDANCE KID"	BURT BACHARACH (A&M SP 4227) (8T 4227) (4T 4227) (CT 4227)	27	62	CUCUMBER CASTLE	BEE GEES (Atco SD 33-327) (TP 33-327) (33-327)	52	95	AIRPORT LOVE THEME	VINCENT BELL (Decca DL 75212) (6-5212) (73-5212)	—
29	I'LL NEVER FALL IN LOVE AGAIN	DIONNE WARWICK (Scepter 581)	29	63	WORKINGMAN'S DEAD	GRATEFUL DEAD (Warner Bros. WS 1869) (8WM 1869) (CWX 1869)	75	96	OLIVER AGAIN	(Crewe CR 1344)	94
30	SELF PORTRAIT	BOB DYLAN (Columbia C2X 30050) (C2A 30050) (C2T 30050)	67	64	LED ZEPPELIN II	(Atlantic SD 8236) (8236)	47	97	THEME FROM "Z"	HENRY MANCINI (RCA LSP 4350) (P8S 1583) (PK 1583)	99
31	SENTIMENTAL JOURNEY	RINGO STARR (Apple SW 3365) (8XT 3365) (4XT 3365)	26	65	ENGELBERT HUMPERDINCK	(Parrot PAS 71030) (M 79830) (X 79430) (X 79630)	61	98	VEHICLE	IDES OF MARCH (Warner Bros. WS 1863) (8WM 1863) (CWX 1863)	—
32	RIGHT ON	SUPREMES (Motown MS 705) (M8 1705) (M75 708)	36	66	FAREWELL	DIANA ROSS & THE SUPREMES (Motown MS 702) (M8 1702) (M75 702)	54	99	TOM JONES LIVE IN LAS VEGAS	(Parrot PAS 71031) (M 7983) (X 79431) (X 70631)	74
33	EASY RIDER	ORIGINAL SOUNDTRACK (Dunhill DSK 50063) (8RM 2026) (CRM 2026)	34	67	SPIRIT IN THE SKY	NORMAN GREENBAUM (Reprise RS 6365)	63	100	MOTT THE HOPPLE	(Atlantic SD 8258) (TP 8258) (CS 8258)	—

# Basic Album Inventory

A check list of best selling pop albums other than those appearing on the CASH BOX Top 100 Album chart. Feature is designed to call wholesalers' & retailers' attention to key catalog, top steady selling LP's, as well as recent chart hits still going strong in sales. Information is supplied by manufacturers. This is a weekly revolving list presented in alphabetical order. It is advised that this card be kept until the list returns to this alphabetical section.

## ROULETTE (Con't)

Tommy James & Shondells	Travelin'	SR42044
Ronnie Hawkins & Band	Best of Ronnie Hawkins	SR42045
Don Cooper	Bless The Children	SR42046
Morganmasondowns	Morganmasondowns	SR42047
Sonny Stitt	Stardust	SR42048
Morning Dew	Morning Dew	SR42049
Original Cast	Billy Noname	SROC-11

## SCEPTER

The Shirelles	The Shirelles Greatest Hits	S507
Dionne Warwick	Presenting Dionne Warwick	S508
Dionne Warwick	Anyone Who Had A Heart	S517
Dionne Warwick	Make Way For Dionne Warwick	S523
Dionne Warwick	The Sensitive Sound Of Dionne Warwick	S528
Dionne Warwick	Here I Am	S531
Dionne Warwick	Dionne In Paris	S534
B. J. Thomas	I'm So Lonesome I Could Cry	S535
Dionne Warwick	Here Where There Is Love	S555
Dionne Warwick	On Stage & In Movies	S559
Dionne Warwick	The Windows Of The World	S563
Dionne Warwick	Dionne Warwick's Golden Hits—Pt. 1	S565
Dionne Warwick	Dionne Warwick In Valley Of The Dolls	S568
B. J. Thomas	Everybody's Out of Town	582
Dionne Warwick	I'll Never Fall in Love Again	581
B. J. Thomas	Raindrops Keep Falling On My Head	580
B. J. Thomas	Greatest Hits Part I	578
Dionne Warwick	Greatest Hits Part II	577
B. J. Thomas	Young and In Love	576
Dionne Warwick	Dionne Warwick's Greatest Motion Picture Hits	575
Dionne Warwick	Soulful	573
Dionne Warwick	Promises, Promises	571
B. J. Thomas	On My Way	570

## SKYE

Cal Tjader	Solar Heat	SK-1
Gary McFarland	Does The Sun Really Shine On The Moon	SK-2
Gabor Szabo	Bacchanal	SK-3
Grady Tate	Windmills Of My Mind	SK-4D
Armando Peraza	Wild Thing	SK-5D
Cal Tjader	Cal Tjader Sounds Out Burt Bacharach	SK-6
Gabor Szabo	Dreams	SK-7
Gary McFarland	America The Beautiful	SK-8
Bonnie & Wendy Flower	Genesis	SKD-1006
Grady Tate	Feeling Life	SK-1007D
Gabor Szabo	Gabor Szabo 1969	SK-9
Cal Tjader	Cal Tjader Plugs In	SK-10

Grady Tate with the Gray McFarland Orch.	Slaves	SK-11
Ruth Brown	Black Is Brown and Brown Is Beautiful	SK-13
Gary McFarland	Gary McFarland Today	SK-14
Lena Horne & Gabor Szabo	Lena & Gabor	SK-15

## SOLID STATE

Jimmy McGriff	The Big Band	18001
Jimmy McGriff	A Bag Full Of Soul	18002
Thad Jones, Mel Lewis	Presenting The Jazz Orch.	18003
Presenting Joe Williams & Jazz Orch.		18008
Johnny Lytle	A Man & A Woman	18014
Thad Jones, Mel Lewis	Live At The Village Vanguard	18016
Jimmy McGriff	Bag Full Of Blues	18017
King Pleasure	Mr. Jazz	18021
Dizzy Gillespie	Jazz For A Sunday Afternoon, Vol. 1	18027
Dizzy Gillespie	Jazz For A Sunday Afternoon, Vol. 2	18028
Jimmy McGriff	I've Got A Woman	18030
Dizzy Gillespie	Live At The Village Vanguard	18034
Jimmy McGriff	Honey	18036
Chick Corea	Now He Sings, Now He Sobs	18039
Billie Holiday	Ladylove	18040

## SOLID STATE (Con't)

Be Proud	18044
The Worm	18045
Little Green Apples	18047
Monday Night	18048
Head Hunters	18050
Step One	18053
It's My Way	18054

## SONGBIRD

The Second Coming Of Christ (Sermon)	Songbird 208
Presenting The Untouchables	Songbird 209
The Rose Of Sharon	151
The Gentlemen Of Song	157
	153

Heart And Soul	154
God Is Love	155

He Did It All	159
Close To Thee	SBLP 213 LRS 11287/11288

	SBLP 216 LRS 11358/11359
--	--------------------------

## STARDAY

Hank & Lewie Wickham	Little Bit Late	SLP 462
Red Sovine	I Know You're Married	SLP 459

The Best Of Cowboy Copas	SLP 458
The Best Of George Morgan	SLP 457

The Best Of Carl Story	SLP 455
Best Of The Truck Drivers	SLP 454

Exciting Young J. David Sloan	SLP 453
Various Stars Of Hee Haw	Country Music Laugh Out

Golden Gospel Best Of The Lewis Family	SLP 452
Buck Owens	Sweethearts In Heaven

Red Sovine	Who Am I
Best Of Johnny Bond	SLP 446

Willis Brothers	Bummin' Around
Red Sovine	Closin' Time Til Dawn

Golden Hits Of George Jones	SLP 440
T. Hill's Band	SLP 442

Dolly Parton & George Jones	SLP 441
Willis Brothers	SLP 444

Red Sovine	SLP 445
Various	SLP 444

Johnny Bond	SLP 442
Willis Brothers	SLP 441

Various	SLP 440
Various	SLP 439

George Jones	SLP 429
Willis Brothers	SLP 428

Red Sovine	Hey, Mr. Truck Driver
Various	Phantom 309

Red Sovine	Man Behind The Wheel
Various	Giddyup Go

Johnny Bond	That's Truck Driving
Willis Brothers	Queens Of Country Music

Various	Ten Little Bottles
Various	Give Me 40 Acres

Flatt & Scruggs/ Jim & Jesse	SLP 323
	SLP 306

	SLP 323
	SLP 306

	SLP 250
	SLP 386

## STEED

The Illusion	Together (As A Way Of Life)	ST37005
Andy Kim	Baby I Love You	ST004



# TOP 100 Albums

101 TO 140

101 AIRPORT Original Soundtrack (Decca DL 79173)	111 LET IT BLEED Rolling Stones (London NPS 4) (M 72167) (X 17167) (X 57167)	121 WILLY AND THE POORBOYS Creedence Clearwater Revival (Fantasy 8397)	131 HE AIN'T HEAVY, HE'S MY BROTHER Hollies (Epic BN 26538) (N18-10262) (N16-10262)
102 HERB ALPERT & THE TIJUANA BRASS GREATEST HITS (A&M SP 4245) (8T 4245) (4T 4245) (CS 4245)	112 BRIDGE OVER TROUBLED WATER Ray Conniff (Columbia 1022) (18 10 1022) (16 10 1022)	122 I LOOKED UP Incredible String Band (Elektra EKS 74061) (M8 4061)	132 TRAVELIN' Tommy James & The Shondells (Roulette SR 42044)
103 MOONDANCE Van Morrison (Warner Bros. WS 1835) (8WM 1835) (CWX 1836)	113 LEON RUSSELL (Shelter 1001)	123 CROW BY CROW (Amaret ST 5006) (M-55006)	133 LIVE PEACE IN TORONTO 1969 Plastic Ono Band (Apple 3362) (8XT 3362) (4XT 3362)
104 SAVAGE GRACE (Reprise RS 6399) (8RM 6399) (CWX 6399)	114 FANCY Bobbie Gentry (Capitol ST 428) (8XT 428) (4XT 428)	124 THE BAND (Capitol STAO 132) (8XT 132) (4XT 132)	134 HELLO DOLLY Original Soundtrack (20th Century Fox DICS 5103)
105 RAW SIENNA Savoy Brown (Parrot 71036) (M-79836) (M-79636)	115 GIMME DAT DING Pipkins (Capitol ST 483) (8XT 483) (4XT 483)	125 EVERYBODY'S OUT OF TOWN B. J. Thomas (Scepter 582)	135 ANDY WILLIAMS' GREATEST HITS (Columbia KCS 9979) (18 10 0870) (16 10 0870)
106 APPLAUSE Original Cast (ABC OCS 11)	116 CAPTURED LIVE AT THE FORUM Three Dog Night (Dunhill DS 50068) (850068) (450068) (550068)	126 THIS GIRL'S IN LOVE WITH YOU Aretha Franklin (Atlantic SD 8248) (TP 8248) (CS 8248)	136 OLIVER Original Soundtrack (Colgems COSD-5501) (08-CB-1003) (OK CG-1003)
107 PURLIE Original Cast (Ampex A 40101) (8T-L80101) (CAS-L50101)	117 "Z" Original Soundtrack (Columbia OS 3370) (18 12 0046)	127 BARBRA STREISAND'S GREATEST HITS (Columbia KCS 9968) (18 10 0852) (16 10 0852)	137 ON TOUR Delaney & Bonnie & Friends With Eric Clapton (Atco SD 326) (TP 326) (CS 326)
108 COME TOGETHER Ike & Tina Turner & The Ikettes (Liberty LST 7637)	118 WALKING IN SPACE Quincy Jones (A&M SP 3023) (8T 3023) (4T 3023) (CT 3023)	128 THE LAST POETS (Douglas 3)	138 FUNNY GIRL Original Soundtrack (Columbia BOX 3220) (COL 19 12 0034) (COL 14 12 0034) (16 12 0034)
109 MIDNIGHT COWBOY Original Soundtrack (United Artists UA 5198) (U-3035) (K-9035)	119 NASHVILLE BY CARR Vikki Carr (Liberty LST 11001)	129 ROD STEWART ALBUM (Mercury SR 61237)	139 GLADYS KNIGHT & THE PIPS GREATEST HITS (Soul SS 723) (S8 1723) (S75 723)
110 STAND! Sly & The Family Stone (Epic BN 26456) (N 18-10186) (N 14-10186) (N 16-10186)	120 REAL FRIENDS Friends Of Distinction (RCA LPS 4313) (PBS 1555) (PK 1555)	130 EMPTY ROOMS John Mayall (Polydor 4010) (8F 4010) (CR 4010)	140 CLOSING THE GAP Michael Parks (MGM SE 4646)





# CashBox Looking Ahead

- |                                                                                                                                                                                                                                                                                                                                                                                                                                                                                                                                                                                                                                                                                                                                                                                                                                                                                                                                                                                                                                                                                                                                                                                                                                                                                                                                                                                                                                                                                                                                                                                                                                                                                                                                                                                                       |                                                                                                                                                                                                                                                                                                                                                                                                                                                                                                                                                                                                                                                                                                                                                                                                                                                                                                                                                                                                                                                                                                                                                                                                                                                                                                                                                                                                                                                                                                                                                                                                                                                                                                                                                            |
|-------------------------------------------------------------------------------------------------------------------------------------------------------------------------------------------------------------------------------------------------------------------------------------------------------------------------------------------------------------------------------------------------------------------------------------------------------------------------------------------------------------------------------------------------------------------------------------------------------------------------------------------------------------------------------------------------------------------------------------------------------------------------------------------------------------------------------------------------------------------------------------------------------------------------------------------------------------------------------------------------------------------------------------------------------------------------------------------------------------------------------------------------------------------------------------------------------------------------------------------------------------------------------------------------------------------------------------------------------------------------------------------------------------------------------------------------------------------------------------------------------------------------------------------------------------------------------------------------------------------------------------------------------------------------------------------------------------------------------------------------------------------------------------------------------|------------------------------------------------------------------------------------------------------------------------------------------------------------------------------------------------------------------------------------------------------------------------------------------------------------------------------------------------------------------------------------------------------------------------------------------------------------------------------------------------------------------------------------------------------------------------------------------------------------------------------------------------------------------------------------------------------------------------------------------------------------------------------------------------------------------------------------------------------------------------------------------------------------------------------------------------------------------------------------------------------------------------------------------------------------------------------------------------------------------------------------------------------------------------------------------------------------------------------------------------------------------------------------------------------------------------------------------------------------------------------------------------------------------------------------------------------------------------------------------------------------------------------------------------------------------------------------------------------------------------------------------------------------------------------------------------------------------------------------------------------------|
| <p><b>1 RUNAWAY PEOPLE</b><br/>(Drive-In/Westward — BMI)<br/>Dyke &amp; Blazers (Original Sound 96)</p> <p><b>2 WAR</b><br/>(Jobete — BMI)<br/>Edwin Starr (Gordy 7097)</p> <p><b>3 DOWN BY THE RIVER</b><br/>(Cotillion/Broken Arrow — BMI)<br/>Brooklyn Bridge (Buddah 179)</p> <p><b>4 MASH</b><br/>(Twentieth Century — ASCAP)<br/>Al De Lory (Capitol 230)</p> <p><b>5 I.O.I.O.</b><br/>(Casserole — BMI)<br/>Bee Gees (Atco 6752)</p> <p><b>6 CAN'T STOP LOVIN' YOU</b><br/>(Felsted — BMI)<br/>Flirtations (Deram 85062)</p> <p><b>7 I'LL BE THERE</b><br/>(Danian/Virtu/Schochie Bug — ASCAP)<br/>Eddie Holman (ABC 11265)</p> <p><b>8 BIG YELLOW TAXI</b><br/>(Siquomb — BMI)<br/>Joni Mitchell (Reprise 0906)</p> <p><b>9 IF MY HEART COULD SPEAK</b><br/>(Lois — BMI)<br/>Manhattans (Deluxe 122)</p> <p><b>10 LIGHTS OF TUCSON</b><br/>Jim Campbell (Laurie)</p> <p><b>11 JUST A LITTLE BIT MORE</b><br/>(Assorted — BMI)<br/>Intrigues (Yew 1007)</p> <p><b>12 EVE OF DESTRUCTION</b><br/>(Trousdale — BMI)<br/>Turtles (White Whale 355)</p> <p><b>13 WITCH</b><br/>Rattles (Probe 480)</p> <p><b>14 MONSTER MASH</b><br/>(Garpax Music Co./Capizzi Music — BMI)<br/>Boris Pickett (Parrot 348)</p> <p><b>15 IN THE SUMMERTIME</b><br/>(Our — Dorset)<br/>Mungo Jerry (Janus 1299)</p> <p><b>16 DOWN BY THE RIVER</b><br/>Buddy Miles (Mercury 70386)</p> <p><b>17 HEY MR. BALLOON MAN</b><br/>(Finius Myth/Sunbeam — BMI)<br/>Ray Hildebrand (Metromedia 175)</p> <p><b>18 LET'S MAKE EACH OTHER HAPPY</b><br/>(Broadside/New Beat/Five Illusion — BMI)<br/>Illusion (Steed 726)</p> <p><b>19 ROLL AWAY THE STONE</b><br/>(Sky Hill — BMI)<br/>Leon Russell (Shelter 301)</p> <p><b>20 LET ME LOVE YOU ONE MORE TIME</b><br/>(Morro — BMI)<br/>Jerry Ross Symposium (Colossus 119)</p> | <p><b>21 A LOVE IS THERE</b><br/>Bridge (Roulette 7081)</p> <p><b>22 FORGET IT, I GOT IT</b><br/>(Irving — BMI)<br/>Ambergris (Paramount 0027)</p> <p><b>23 IT'S YOUR LIFE</b><br/>Andy Kim (Steed 727)</p> <p><b>24 SOLITARY MAN</b><br/>Neil Diamond (Bang 578)</p> <p><b>25 TWO LITTLE ROOMS</b><br/>(Multimood — BMI)<br/>Janet Lawson (United Artists 50671)</p> <p><b>26 SNOWBIRD</b><br/>(Beechwood Music Corp. — BMI)<br/>Ann Murray (Capitol 2738)</p> <p><b>27 CIRCLES IN THE SAND</b><br/>(Sufi Pipkin — BMI)<br/>Frankie Valli (Philips 40680)</p> <p><b>28 WHEREFORE AND WHY</b><br/>(Warner Bros. — ASCAP)<br/>Johnny Mathis (Columbia 45183)</p> <p><b>29 DO I LOVE YOU</b><br/>(Hill &amp; Range/Mother Bertha — BMI)<br/>Jay &amp; The Americans (U.A. 50683)</p> <p><b>30 EXUMA, THE OBEAH MAN</b><br/>Exuma (Mercury 73084)</p> <p><b>31 I GOTTA GET AWAY</b><br/>(Gaucho — BMI)<br/>Ray Godfrey (Spring 104)</p> <p><b>32 IF JOHNNY COMES MARCHING HOME</b><br/>(Transco/Banks — BMI)<br/>Goliath (ABC 11267)</p> <p><b>33 NEVER GOIN' HOME</b><br/>(Pocket Full — BMI)<br/>Owen B. (Janus 123)</p> <p><b>34 IF YOU' KNEW HIM LIKE I DO</b><br/>(Blockbuster — BMI)<br/>Barbara Mason (National General 005)</p> <p><b>35 THE THRILL IS GONE</b><br/>(Leo Feist — ASCAP)<br/>Aretha Franklin (Atlantic 2731)</p> <p><b>36 WATCH WHAT HAPPENS</b><br/>(Peer Southern — BMI)<br/>Lena Horne (Skye 4523)</p> <p><b>37 WHERE YOU LOVE LIKE HEAVEN</b><br/>Peggy Lipton (Ode 70 66001)</p> <p><b>38 I SHALL BE RELEASED</b><br/>(Dwarf Music — ASCAP)<br/>Freddie Scott (Probe 481)</p> <p><b>39 SUZIE-Q</b><br/>Jose Feliciano (RCA 0358)</p> <p><b>40 CALIFORNIA ROCK'N ROLL</b><br/>(Crowfoot — ASCAP)<br/>Crowfoot (Paramount 0029)</p> |
|-------------------------------------------------------------------------------------------------------------------------------------------------------------------------------------------------------------------------------------------------------------------------------------------------------------------------------------------------------------------------------------------------------------------------------------------------------------------------------------------------------------------------------------------------------------------------------------------------------------------------------------------------------------------------------------------------------------------------------------------------------------------------------------------------------------------------------------------------------------------------------------------------------------------------------------------------------------------------------------------------------------------------------------------------------------------------------------------------------------------------------------------------------------------------------------------------------------------------------------------------------------------------------------------------------------------------------------------------------------------------------------------------------------------------------------------------------------------------------------------------------------------------------------------------------------------------------------------------------------------------------------------------------------------------------------------------------------------------------------------------------------------------------------------------------|------------------------------------------------------------------------------------------------------------------------------------------------------------------------------------------------------------------------------------------------------------------------------------------------------------------------------------------------------------------------------------------------------------------------------------------------------------------------------------------------------------------------------------------------------------------------------------------------------------------------------------------------------------------------------------------------------------------------------------------------------------------------------------------------------------------------------------------------------------------------------------------------------------------------------------------------------------------------------------------------------------------------------------------------------------------------------------------------------------------------------------------------------------------------------------------------------------------------------------------------------------------------------------------------------------------------------------------------------------------------------------------------------------------------------------------------------------------------------------------------------------------------------------------------------------------------------------------------------------------------------------------------------------------------------------------------------------------------------------------------------------|

## Uni 'Care Packages' Serve To Introduce Label's Key Talent

LOS ANGELES — Close on the heels of MCA's newly created Manufacturing, Marketing and Distribution organization, the Uni Records division, under vp general manager Russ Regan, has instituted a plan designed primarily to familiarize MCA's sales force with the label's wares.

A number of "care" packages comprised of existing and new materials from Uni's promotion, advertising and press information departments is now shipping to MCA distribution centers. "They contain," said Rick Frio, Uni's national sales manager, "a potpourri of merchandising aids on current targets like Daybreak ('Good Morning Freedom'), England's Elton John, Dewey Martin and consistent sellers like Bill Cosby, Fever Tree and Neil Diamond."

The varied assortment includes four-color consumer tabloids on Neil Diamond and Fever Tree, European press reprints pertaining to Elton John, merchandisers for use in conjunction with Dick Glasser's "Artistry in Sound" LP, including a radio spot transcription and a primer on Uni Records executive staff. Additionally, a weekly wrap-up, The Uni Form, from Pat Pipolo, Uni's national promotion director, is in the works.

Frio said, "product can derive a large amount of 'built-in' exposure if presented properly: then, of course, the 'in the groove' requisite takes over. A good example is our forthcoming album, "Dewey Martin and Medicine Ball." By itself, it is merely a name and a title, however, a well informed representative would know that Martin is the last member of the legendary Buffalo Springfield, and the title is also the

name of the artist's new group. Certainly worth noting in lieu of other Buffalo alumni who have gone on the stardom, i.e. Crosby, Stills, Nash and Young, Poco etc."

Further attesting to Uni's logic in providing a consistent flow of information to the field, is the momentary debut of "Badfoot Brown and the Bunions Bradford Funeral and Marching Band." The LP actually spotlights a new facet to the talent of Bill Cosby. A serious endeavor, it was composed by the actor-comedian and also showcases his prowess on a number of instruments. The full orchestra, with Cosby at the helm, will auspiciously launch the LP at the Newport Jazz Festival July 12.

## Four ABC Dunhill LP's Readied For Release

NEW YORK — ABC/Dunhill will release four LP's this week according to Jay Lasker, President of the company. Set for release are LP's by new English group Freedom, Greatest Hits anthology by various ABC/Dunhill artists, the first LP by Bush, another new English group, and the new Roy Head LP, his first for label.

## RCA Signs Osmosis: New 7 Man Group

NEW YORK — RCA Records has signed a group called, Osmosis, whose debut album, titled "Osmosis" will be released in July. Independently produced by Dave Blume for Red River Productions, the seven piece group is spearheaded by veteran jazz musician Charlie Mariano.

Besides Mariano on flute, alto sax, soprano sax and nathaswaram, (an Oriental reed instrument), and Bobby Knox as vocalist, Osmosis is Danny Comfort, bass; Lou Peterson, drums; Bobby Clark, percussion, drums; Andy Steinhorn, guitar (background vocals) and Charlie Bechler, keyboards, melodic, tympani and chimes).

The group is scheduled to play the Boston workshop in August with a free concert tour being planned for the fall for colleges, high schools and junior high schools in the New England area. The group will be playing in Japan later this year, with Mariano taking a solo engagement in Finland for three weeks starting July 1.

## Philips Names Grant

NEW YORK — The Philips Recording Company, Inc. has named David Grant director of national sales. The announcement was made by Robert Teitelman, v.p. and general manager. Grant had been associated with Columbia Records for seven years, serving as an account executive in custom record productions.

## Howard Cook Dies

NEW YORK — Howard Cook, vet public relations man and trade writer, died here at St. Vincent's Hospital on Monday, June 15 of lung disease. He was 40 years old. In recent years, Cook ran his own public relations firm in New York.



POP CARNE — Judy Carne, former "Laugh-In" regular and current star of the Broadway revival of "The Boy Friend," recently dropped into Korvette's Fifth Avenue record department to autograph copies of the Decca cast LP of the show. Judy is shown flanked on the left by Korvette exec Ben Bernstein and on the right by Harold Komisar, Decca sales exec.



# CashBox Radio Active

A survey of key radio stations in all important markets throughout the country to determine by percentage of those reporting which releases are being added to station play lists this week for the first time and also the degree of concentration combining previous reports. Percentage figures on left indicate how many of the stations, reporting this week have added the following titles to their play list for the first time. Percentage figures on right include total from left plus the percentage title received in prior week or weeks.

% OF STATIONS ADDING TITLES TO PROG. SCHED. THIS WEEK	TITLE	ARTIST	LABEL	TOTAL % OF STATIONS TO HAVE ADDED TITLES TO PROG. SCHED. TO DATE
62%	Spill The Wine—Eric Burdon & War—MGM			62%
33%	Tell It All Brother—Kenny Rogers & First Edition—Reprise			33%
32%	Paper Mache—Dion Warwick—Scepter			32%
31%	Yellow River—Christi—Epic			40%
30%	Why Can't I Touch You—Ronnie Dyson—Columbia			85%
30%	Superman—Ides Of March—Warner Brothers			72%
29%	Everything A Man—Glen Campbell—Capitol			41%
26%	Your Own Back Yard—Dion—Warner Brothers			34%
22%	Summertime Blues—Who—Decca			22%
22%	Sunshine—Archies—Kirshner			64%
21%	My Marie—Engelbert Humperdinck—Parrot			56%
20%	In The Summertime—Mungo Jerry—Janus			60%
20%	Que Sera Sera—Mary Hopkin—Apple			41%

19%	Candida—Dawn—Bell	19%
18%	It's Your Life—Andy Kim—Steed	18%
17%	Black Hands, White Cotton—Caboose—Enterprise	17%
17%	Do You See My Love—Jr. Walker—Soul	17%
16%	God Knows I Love Her—Classics Four—Imperial	16%
16%	I'll Be Right There—Tyrone Davis—Dakar	60%
14%	After The Feeling Is Gone—Lulu—Atco	14%
14%	Apartment 21—Bobbie Gentry—Capitol	14%
12%	No Arms Can Ever Hold Me—Bobby Vinton—Epic	12%
11%	Big Yellow Taxi—Neighborhood—Big Tree	59%
11%	Song From Mash—Al De Lory—Capitol	46%
11%	Destiny—Jose Feliciano—RCA	51%
10%	Mississippi Queen—Mountain—Windfall	93%

### LESS THAN 10% BUT MORE THAN 5%

Sly, Slick & Wicked—Lost Generation—Brunswick	33%	Groovy Situation—Gene Chandler—Mercury	12%
Make It With You—Bread—Elektra	97%	Signed, Sealed Delivered, I'm Yours—Stevie Wonder—Tamla	90%
IOIO—Bee Gees—Atco	29%	Maybe—Three Degrees—Roulette	58%
Witch—Rattles—Probe	52%	The Thrill Is Gone—Aretha Franklin—Atlantic	19%

beverly hills record company, inc • 6430 sunset blvd • hollywood, calif. 90028 • (213) 461-4409/461-4400



IF WE'RE GONNA SPEND THIS KIND OF MONEY FOR AN AD, THEN YOU'D BETTER BELIEVE THAT WE HAVE SOMETHING IMPORTANT TO SAY . . .

*"Both of these records are on Top 40 & MOR Stations. We refuse to bore you with the usual trivia of call letters but ask in earnest . . . Please listen to them."*

**JAYE P. MORGAN**

BH 45-9349

**"I've Got An Awful Lot Of Losing You To Do"**

**William Loose Orchestra**

**"THEME OF 'THE VIXEN' "**

BH-45-9347

Hey, Thanks!!!!

*W. Loose*

It's nice  
to be associated  
with talented people

Van Morrison

Turley Richards

Miriam Makeba

Daybreak

Grinder's Switch

Barry Goldberg

Johnny Rivers

Dorothy Morrison

The Happenings

Johnny Maestro

Country Joe and the Fish

John Cale

Schwaid-Merenstein & Thau

*Production-Publishing-Management*

10 West 66th Street, New York, N.Y.

212-787-5200

I CAN'T TELL THE BOTTOM  
FROM THE TOP  
THE HOLLIES.....EPIC  
Anne-Rachel Music

PRIMROSE LANE  
O.C. SMITH.....COLUMBIA  
Gladys Music

I CAN'T SEE TO SAY GOODBYE  
JERRY LEE LEWIS.....SUN  
Anne-Rachel Music

LUZIANA RIVER  
VAN TREVOR..ROYAL AMERICAN  
Noma Music  
S-P-R Music  
Birmingham Music

TOMORROW NEVER COMES  
SLIM WHITMAN.....IMPERIAL  
Noma Music

YELLOW RIVER  
CHRISTIE.....EPIC  
LEAPY LEE.....DECCA  
Noma Music

SHE'S AS CLOSE AS I CAN GET  
(TO LOVING YOU)  
BILLY WALKER.....MGM  
Hill & Range  
Blue Crest

ARE YOU GROWING TIRED OF MY  
LOVE  
CUPIDS INSPIRATION.....DATE  
Noma Music  
Inquiry Music

DO I LOVE YOU  
MONDAY BLUES.....VAULT  
Hill & Range Songs  
Mother Bertha

**THE ABERBACH GROUP**  
241 West 72 Street, New York N.Y.

## New Additions To Radio Playlists - Secondary Markets

A broad view of the titles many of radio's key Top 40 stations added to their "Playlists" last week.

**WGLI — Babylon, N.Y.**  
Everything A Man—Glen Campbell—Capitol  
Why Can't I Touch You—Ronnie Dyson—Columbia  
Yellow River—Christi—Epic  
Paper Mache—Dion Warwick—Scepter  
It's Your Life—Andy Kim—Steed

**WTRY — Albany, Schenectady, Troy, N.Y.**  
Sunshine—Archies—Kirshner  
I'll Be Right There—Tyrone Davis—Dakar  
Tighter—Alive & Kicking—Roulette  
Destiny—Jose Feliciano—RCA  
Suzie Q—Jose Feliciano—RCA  
My Marie—Engelbert Humperdinck—Parrot  
Yellow River—Christi—Epic  
If Johnny Comes Marching Home—Goliath—ABC  
Everything A Man—Glen Campbell—Capitol  
Picks: Freedom Blues—Little Richard—Reprise  
Long Long Time—Linda Ronstadt—Capitol  
It's Your Life—Andy Kim—Steed  
In The Summer—Mungo Jerry—Janus

**WKIX — Raleigh, N.C.**  
Superman—Ides Of March—Warner Bros.  
I'll Be Right There—Tyrone Davis—Dakar  
Summertime Blues—Who—Decca  
Make It With You—Bread—Elektra

**KLEO — Wichita, Kansas**  
Spill The Wine—Eric Burdon—MGM  
Your Own Back Yard—Dion—Warner Bros.  
Take You Higher—Sly & Family Stone—Epic

**WLOF — Orlando, Fla.**  
Going Back To Living In The City—Peggy Scott  
& Jo Jo Benson—SSS  
Apartment 21—Bobbi Gentry—Capitol  
Snow Bird—Ann Murry—Capitol  
I'm Gonna Capture You—Terry Jacks—Parrot  
Never Goin' Home—Owen B.—Janus  
Pick: Accident—Thunder Clap Neuman—Track

**WJET — Erie, Pa.**  
Don't It Make You—Brook Benton—Cotillion  
Make It With You—Bread—Elektra  
Superman—Ides Of March—Warner Bros.  
Whose Gonna Take The Blame—Smokey Robinson  
—Tamla  
Pick: Pearl—Tommy Roe—ABC

**WSGN — Birmingham, Ala.**  
Sunshine—Archies—Kirshner  
Signed, Sealed—Stevie Wonder—Tamla  
Check Out Your Mind—Impressions—Curton  
I Just Can't Help Believing—B.J. Thomas—  
Scepter  
Everything A Man Could Ever Need—Glen  
Campbell—Capitol  
Overture From Tommy—Assembled Multitude—  
Atlantic

**WBAM — Montgomery, Ala.**  
God Knows I Love Her—Classics Four—Imperial  
Tell It All Brother—Kenny Rogers—Reprise  
Hey Bull Dog—Bill Deal—Heritage  
After The Feeling—Lulu—Atco  
Superman—Ides Of March—Warner Bros.  
Save Your Love—Tony Joe White—Monument  
Spill The Wine—Eric Burdon—MGM  
Close To You—Carpenters—A&M  
Do You See My Love—Jr. Walker—Soul

**WLAV — Grand Rapids, Mich.**  
Come On Down—Savage Grace—Reprise  
Superman—Ides Of March—Warner Bros.  
Candida—Dawn—Bell  
Yellow River—Christi—Epic  
I Just Can't—B.J. Thomas—Scepter  
Cinnamon Girl—Neil Young—Reprise  
Que Sera Sera—Mary Hopkin—Apple  
LP: Self Portrait—Bob Dylan—Columbia

**WDRG — Hartford, Conn.**  
Spill The Wine—Eric Burdon—MGM  
Boys In The Band—Spring  
Destiny—Jose Feliciano—RCA  
Mississippi Queen—Mountain—Windfall  
No Arms Can Ever Hold You—Bobby Vinton—Epic

**WIRL — Peoria, Ill.**  
Pick: After The Feeling—Lulu—Atco  
Maybe Three Degrees—Roulette  
I'll Paint You A Song—Mac Davis—Columbia  
Long, Lonely Nights—Dells—Cadet  
Song From MASH—Al De Lory—Capitol  
My Marie—Engelbert Humperdinck—Parrot  
Everything A Man—Glen Campbell—Capitol  
The Green Mamelishi—Fleetwood Mac—Reprise  
Still Got My Head—Soul Survivors—Atco  
Good Morning Freedom—Daybreak—Uni  
Jesus Is Just Alright—Underground Sunshine—  
Intrepid  
IOIO—Bee Gees—Atco

**KIOA — Des Moines Iowa**  
Lay A Little Lovin'—Robin McNamara—Steed  
Are You Ready—Pacific Gas & Electric—Columbia  
I Just Can't Help—B.J. Thomas—Scepter  
Que Sera Sera—Mary Hopkin—Apple  
Passport To The Future—Jean Jacques Perry—  
Vanguard

**WKWK — Wheeling, W. Va.**  
Let The Music Take Your Mind—Kool & Gang—  
De-Lite  
Groovin' With Mr. Bloe—Cool Heat—Forward  
No Arms—Bobby Vinton—Epic  
Destiny—Jose Feliciano—RCA  
Bitter Earth—Satisfaction—Uni  
Candida—Dawn—Bell  
Black Fox—Freddy Robinson—World Pacific  
Everything A Man—Glen Campbell—Capitol  
Why Can't I Touch You—Ronnie Dyson—Columbia  
Two Little Rooms—Janet Lawson—Liberty  
Love Is A Funny Thing—Francis Lai—U. A.

**WHLO — Akron, Ohio**  
In The Summer—Mungo Jerry—Janus  
Summertime Blues—Who—Decca  
Superman—Ides Of March—Warner Bros.  
Roxanna—Wild Butter—United Artists  
Mills Alley—Miss. Abrams—Reprise  
Eleanor Rigby—El Chicano—Kapp  
Give A Women Love—Bobbi Martin—United  
Artists  
God Knows I Love Her—Classics Four—Imperial  
It's Gonna Change—Bobby Goldsboro—United  
Artists

**WIFE — Indianapolis, Ind.**  
Ooh Child—5 Stairsteps—Buddah  
Make It With You—Bread—Elektra

**WKLO — Louisville, Ky.**  
I'll Point You A Song—Mac Davis—Columbia  
God Knows I Love Her—Classics Four—Imperial  
No Arms—Bobby Vinton—Epic  
Spill The Wine—Eric Burdon—MGM  
Pearl—Tommy Roe—ABC  
Close To You—Carpenters—A&M  
Make It With You—Bread—Elektra  
Superman—Ides Of March—Warner Bros.  
Summertime Blues—Who—Decca  
Apartment 21—Bobbi Gentry—Capitol  
I Got You On My Mind—Blue Horizon—Vanguard

**WPRO — Providence, R.I.**  
Tell It All Brothers—Kenny Rogers—Reprise  
Yellow River—Christi—Epic  
After The Feeling—Lulu—Atco  
Summertime Blues—Who—Decca  
Your Own Back Yard—Dion—Warner Bros.  
Make It With You—Bread—Elektra  
Down To The Valley—Nilson—RCA  
Mill Valley—Miss. Abrams—Reprise  
Everything A Man—Glen Campbell—Capitol

**WNHC — New Haven, Conn.**  
Signed, Sealed—Stevie Wonder—Tamla  
Spill The Wine—Eric Burdon—MGM  
Paper Mache—Dion Warwick—Scepter  
Please Baby Please—Realistics—De-Lite  
I've Got An Awful Lot—J.P. Morgan—Beverly  
Hills  
Same Old Feeling—Pickettywitch—Janus  
Make It With You—Bread—Elektra  
Big Yellow Taxi—Neighborhood—Big Tree  
Cottage Cheese—Crow—Amaret

**WING — Dayton, Ohio**  
Make It With You—Bread—Elektra  
Signed, Sealed—Stevie Wonder—Tamla  
I Just Can't Help—B.J. Thomas—Scepter  
Sunshine—Archies—Kirshner  
Superman—Ides Of March—Warner Bros.  
Monster Mash—Bobby Pickett—Parrot  
In The Summer—Mungo Jerry—Janus  
Everything A Man—Glen Campbell—Capitol

**WBBQ — Augusta, Ga.**  
Your Own Back Yard—Dion—Warner Bros.  
Do You See My Love—Jr. Walker—Soul  
In The Summer—Mungo Jerry—Janus  
Sorry Suzanne—Glass Bottle—Avco Embassy  
Solitary Man—Neil Diamond—Bang  
Comin' Apart—Poza Seco—Certron  
Mills Alley—Miss. Abrams—Reprise  
One Day Of Our Life—Andy Williams—Columbia

**WAVZ — New Haven, Conn.**  
Destiny—Jose Feliciano—RCA  
Down By The River—Buddy Miles—Mercury  
Superman—Ides Of March—Warner Bros.  
Long, Lonely Nights—Dells—Cadet  
Bless The Children—Don Cooper—Roulette  
Picks: Paper Mache—Dion Warwick—Scepter  
Do You See My Love—Jr. Walker—Soul  
I'll Paint You A Song—Mac Davis—Columbia  
Were All Playing In The Same Band—Bert  
Sommer—Eleuthera

**WAPE — Jacksonville, Fla.**  
After The Feeling—Lulu—Atco  
Superman—Ides Of March—Warner Bros.  
Ooh Child—5 Stairsteps—Buddah  
Do You See My Love—Jr. Walker—Soul  
Tell It All Brother—Kenny Rogers—Reprise

**WPOP — Hartford, Conn.**  
She Cried—Lettermen—Capitol  
Same Old Feeling—Pickettywitch—Janus  
Maybe—Three Degrees—Roulette  
Ohio—Crosby, Stills, Nash & Young—Atlantic  
Two Little Rooms—Janet Lawson—U.A.  
Paper Mache—Dion Warwick—Scepter  
IOIO—Bee Gees—Atco  
Summertime Blues—Who—Decca  
Wigwam—Bob Dylan—Columbia  
Lucrinas Mac Evil—Blood Sweat & Tears—  
Columbia  
Something's Goin' On—Blood Sweat & Tears—  
Columbia

### Handleman Picks Novick

**DETROIT** — The Handleman Company has appointed Marvin Novick as controller. Prior to joining the record and tape distribution company, Novick, a certified public accountant, served as vice-president, finance of Michigan Blue Shield.



COMING  
SOON



© EPIC, Marco Reg. T.M. PRINTED IN U.S.A.

## Pop Picks

### BLOOD, SWEAT & TEARS 3 — Blood, Sweat & Tears — Columbia KS 30090

After a year and a quarter comes the new BS&T set. In that time, it seems, they haven't lost the ultra commercial formula that has launched them to stardom. The extended "Lucretia MacEvil" bears a marked resemblance to "Spinning Wheel" and the instrumental passages in their version of the Stones' "Sympathy For The Devil" seem to have been spun out of the "Blues" cut from the last LP. Aesthetically, the most successful cuts are the low-keyed ones such as "The Battle," on which Steve Katz sings an interesting change of pace lead. "Fire And Rain," and "He's A Runner." Any way you look at it, this one will be high on the charts in no time flat.



### THE ASSOCIATION "LIVE" — Warner Bros. 2WS 1868

This polished seven man group which has had an enviable string of hits is heard in a two record set, recorded live during their recent college tour. Many of their singles successes are featured, among them "Along Comes Mary," "Never My Love," "Windy" and, of course, "Cherish." But there is more, much more — the funky "Dubuque Blues," a full scale production of "Requiem For The Masses," a gently rocking "Babe, I'm Gonna Leave You" — all enhanced by the sounds of crowd response as well as the Association's on-stage banter between songs. Should be a big charter.

### ECOLOGY — Rare Earth — Rare Earth RS 514

Rare Earth, most successful of the new Motown groups on the Rare Earth label, here comes up with their second LP. Most interesting cut on the album is the group's version of the Temptation's smash "(I Know) I'm Losing You," which runs almost eleven minutes. Track was produced by Motown stalwart Norman Whitfield, who has used stereo and echo studio effects with fine results. Set also includes an extended re-working of "Eleanor Rigby." Group has improved musically from the first LP; the long instrumental passages on the set are more together. Should please their many fans.



### HOME — Procol Harum — A&M SP 4261

Hard not to go overboard in praising "Home," the fourth Procol Harum album. While the set is striking on first hearing the album has that extremely rare quality of getting better with further listening. Most noticeable is that there is more of Robin Trower's fine guitar on the cuts, especially "Whiskey Train" and the Mountainesque "Still There'll Be More." Gary Brooker and Keith Reid's writing has improved beyond measure and "Piggy Pig Pig," "The Dead Man's Dream," and the monumental, moody "Whaling Stories" are among the finest work they've yet turned out. Like their last LP, "Salty Dog," this one has a total, cyclical feel to it that increases the classical atmosphere of the album. Sure to be huge as the set is already on the charts.

### THE HAWAIIANS — Original Soundtrack — United Artists UAS 5210

Veteran composer Henry Mancini can always be counted on to come up with consistently original tracks for films and the "Hawaiians" score is no exception. Mancini, whose credits include scores from "Peter Gunn," "Charade," and "Breakfast At Tiffany's," among a host of others, is a stickler for authenticity. Accordingly, he has employed koto, Chinese zither and a number of Oriental woodwinds as solo instruments (film deals with the Chinese emigration to Hawaii). All the cuts are good. "Pineapple Pirates" is most like his old style, evoking images of Mancini's "Mr. Lucky" score. This will do well.



### PERFORMANCE — Original Motion Picture Sound Track — Warner Bros. 2554

A super-charged grab bag of musical sound, this is the track from the upcoming film which stars Mick Jagger. While the Stone is only heard on one cut, the powerful and raunchy "Memo From Turner," there are some stirring numbers by Merry Clayton and Randy Newman. Buffy Sainte-Marie contributes a couple of vocals and a fine mouth bow solo; the Last Poets shake up the premises with "Wake Up, Niggers." A major portion of the music was composed by Jack Nitzsche. This could develop into a sizeable item.

### THE SESAME STREET BOOK & RECORD — Original Cast — Columbia CS 1069

Here is the original cast album of the critically praised and highly successful children's educational television show, "Sesame Street." The album, which showcases the program's regulars in performances of songs from the show, comes with a 24 page color book and a full color poster. Children will be begging their parents for the set, and it could well become a huge seller.



### SUSAN SINGS SONGS FROM SESAME STREET — Scepter SPS 584

Thousands of children will want to own this record, and if enough of their parents buy it for them, it will be a hit. Susan (Loretta Long), one of the stars of "Sesame Street," probably the most acclaimed children's television program of all time, sings, with children's chorus, twelve songs from the show in a bright, cheerful manner. Album was produced by "Sesame Street" musical director Joe Rapose, whose work on the show earned him a 1970 Emmy Award.

## Pop Best Bets

### CALIFORNIA GIRL — Eddie Floyd — Stax STS 2029

Eddie Floyd did nicely with his single of the title tune of this album, and he should do nicely with the set itself. In addition to "California Girl," the popular R&B chanter offers "Rainy Night In Georgia," "People, Get It Together," "Hey There Lonely Girl" and seven others. Eddie's fans should want to save a spot on their record shelves for this one, so have some copies in stock.

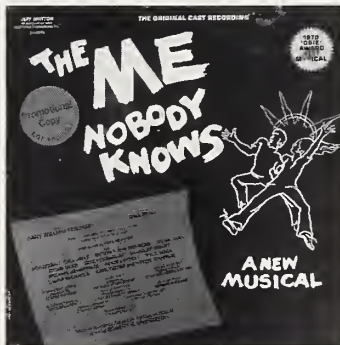

### THE ME NOBODY KNOWS — Original Cast — Atlantic SD 1566

"The Me Nobody Knows," represents, as Clive Barnes wrote, "the victory of the human spirit over circumstances." The show is based on the writings of ghetto children between the ages of 7-18 from the New York City school system and the music is by Gary William Friedman and Will Holt. The score is superb; a powerful statement about the New York people tend to ignore. Particular standouts from the set are "How I Feel," spotlighting Jose Fernandez and Beverly Ann Bremers in a memorable duet, and "Light Sings," a rousing show-stopping number. An important show to see and hear.

### DOC SEVERINSEN'S CLOSET — Doc Severinsen and the Now Generation Brass — Command RSSD-950-S

This LP certainly seems to be a turning point in the career of trumpeter Doc Severinsen. For one thing the music is much more serious than any he has recorded before. Doc's version of King Crimson's epic, "In The Court Of The Crimson King," is seven and a half minutes of musical brilliance. Not the usual middle of the road rendition, the cut takes on new dimensions led by Doc's soaring Spanish-tinged trumpet. Other cuts include "Footprints Of The Giant," based on Bela Bartok melodies and an "Abbey Road" medley. All in all, a surprising and exciting album that could see chart action.

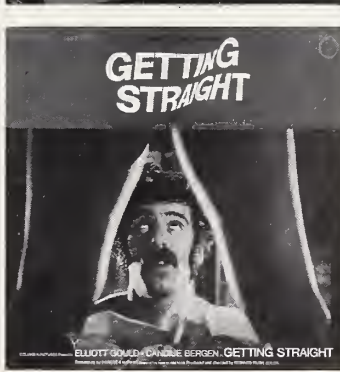
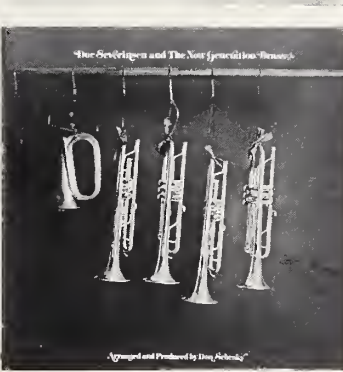

### GETTING STRAIGHT — Original Soundtrack Recording — Colgems COSO-5010

The film score for "Getting Straight" features selections by P.K. Limited and the New Establishment. Composer Ronald Stein conducts several numbers and there are excerpts of dialogue as spoken by the movie's principals, Elliott Gould and Candice Bergen. Title theme was composed by David Gates of the Bread group. Entire package is an attractive one which should get impetus from the popularity of the film.

## Buddy Miles/Chariot

WHISKEY A GO GO, L. A. — I've been sitting here for the last hour trying to think of a really clever way to begin this Buddy Miles review, and I guess this is it. It would have been simple to pull all the old phrases out of the review hat and remix them for the 1000th time, but Buddy Miles, finally, deserves something better, much better.

I've seen the old Buddy Miles Express over a dozen times, in small clubs, concerts, dances, and though Buddy always showed some talent, and the Express was always somewhat competent, they were easily dismissible as "having potential." The new Buddy Miles Band, after an almost disastrous debut at a recent Jimi Hendrix concert, has turned into a first rate rock & soul band, perhaps the only one of its kind, mixing progressive riffs, contemporary lyrics and moving, soulful, driving rhythm into a supercharged show that had the Whiskey overflowing with excitement.

Buddy, who at one time was afraid to come out from behind his drums, now spends more than half the show center stage, leaving the drumming to someone else. It would be nice to say that Buddy moves with the grace of an antelope, but that's too much to expect from one his size. Yet, Buddy has started to develop a sense of inner motion that lets him appear at ease as he moves across the stage.

The new band, 10 pieces with Buddy, is super-tight, and while not as progressive as the Family Stone (and they're not trying to be), they are an evolutionary step above the usual soul band. Tunes ranged from Neil Young's "Down By The River" thru Otis' "Cigarettes & Coffee" (an old Miles favorite) to "Them Changes," the title tune of his latest Mercury LP.

Chariot is an enjoyable hard-rock trio who lack the material to make their musical knowledge leave a lasting impression on an audience.

a.r.

## Traffic

### Bloomsbury People/SRS

ARAGON BALLROOM, CHICAGO — Several thousand fans packed the Aragon Ballroom for the Friday night concert presented by Michael Butler's American Tribal Productions, which successfully took over the room a couple of months back. Traffic, featuring Stevie Winwood, was the headliner and the obvious draw of the evening. Group's first couple of numbers received mediocre response from the audience, but by the time the complete set was over—1 hour 45 minutes and 2 encores later, the crowd was on its feet. The turning point occurred following Stevie Winwood and company's performance of the title tune and excerpts from their newest UA album "John Barleycorn Must Die". From here on the crowd was their's.

A new group, Bloomsbury People, made their debut on the Traffic bill. Together less than a year, they possess an unlimited catalog of original material, some of which was recently incorporated into their current album on MGM. Group's performance this evening, after a rather slow start and some mike difficulties, went over well with the crowd; their outstanding contribution being a number called "Virginia" which showcased their very accomplished individual musicianship. Just prior to the end of the number group members abandoned their instruments and continued the beat with wooden boards on the floor of the stage. Needless to say, the crowd went wild. Members of Bloomsbury People are: Sigmund Snopek III, keyboards; Greg Janick, organ and saxophone; Dennis Lanting, lead guitar; Ding Lorenz, drums; Paul Du Jardin, bass and Jon Wyderka lead singer.

Unfortunately, we only caught the last few minutes of SRS who were also on the bill, but judging from the condition of the crowd at that time we can assure their reception closely equaled that of Traffic. Sorry we missed them.

c.c.

## Pop Best Bets

### APPEARING NIGHTLY AT THE PIANO — Merv Griffin — Metromedia MD 1023

Merv Griffin, the noted TV personality, is a fine pianist and has put together a deck of top-notch material that is just right for easy listening. Backed by a full orchestra conducted by Frank Hunter (who also arranged the selections), Merv pours forth lots of good things including "Love Theme From Romeo And Juliet/Tschaikowsky's Romeo And Juliet," "Love's Been Good To Me," "Jean," "Delilah" and "Why Can't I Walk Away." Could do nicely.



### GENE VINCENT — Gene Vincent — Kama Sutra KSBS 2019

Old-time rock'n'roller Gene Vincent surfaces with his second Kama Sutra LP, which showcases his new sound and plenty of new material. In other words, this is today's Vincent, with his rocker days just a pleasant memory. Vincent's into some fine relaxed music that rather defies classification. Certainly "I Need Woman's Love" and "A Million Shades Of Blue" are country-flavored tunes but "Danse Colinda" is bayou music and the extended "Slow Times Comin'," while having C&W lyrics, is arranged in an exciting pure rock manner. Well, whatever you wish to call it, Vincent's singing is deft and sure. And his voice is perfectly suited to each number. Good set that may go places.



### FRANK POURCEL PLAYS MIDNIGHT COWBOY — Paramount PAS 5015

Frank Pourcel conducts his own arrangements of a variety of tunes on this album, and the results add up to a very pleasant and tasteful good music package that should please MOR devotees. Among the numbers to which Pourcel lends his talents are "Midnight Cowboy," "The Impossible Dream," "Un Homme Qui Plait" ("My Kind Of Man"), "I'll Never Fall In Love Again" and "Je T'Aime, Moi Non Plus." Easy on the ear without inducing sleep, this is one of the best LP's of its kind that we've heard in a long while.



### PETE HAMILL'S MURDER AT KENT STATE UNIVERSITY — Narrated By Rosko — Flying Dutchman FDS-127

New York Post columnist Pete Hamill was among the first and most eloquent journalists to speak out against the action of the National Guard at Kent State as well as the demonstrations conducted by construction workers in New York City. A half dozen of his columns, as spoken by WNEW-FM's Rosko, with the musical backing of James Spaulding (alto sax, flute) and Ron Carter (bass) adds up to an album which effectively captures the uncompromising stance of Hamill and is, in itself, a remarkable experience. LP deserves attention.

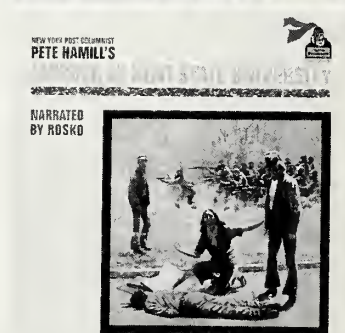

## Jazz Pick

### 3 SHADES OF BLUE — Johnny Hodges With Leon Thomas And Oliver Nelson — Flying Dutchman FDS-120

Veteran jazz saxophonist Hodges recorded this session several weeks before his death. Accompanied by a roster of excellent musicians — Marvin Stamm, Jerome Richardson, Earl Hines, Grady Tate (to name only a few) — and fusing his talents with those of Leon Thomas and band leader and arranger Oliver Nelson, Hodges laid down a superb set. To compliment standards such as "Rockin' In Rhythm" and "Echoes Of Harlem," there's Thomas singing his wryly amusing and constantly swinging "Welcome To New York" and the Nelson piece "Yearning," on which Hodges offers a memorable solo. Outstanding entry.

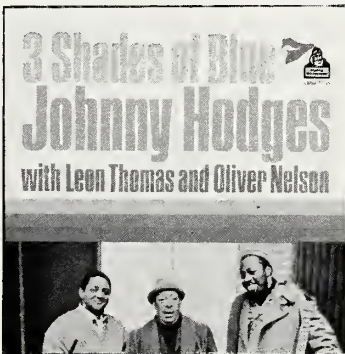

## Classical Pick

### HENRY PURCELL: AYRES — Deller Consort — RCA Victorola VICS 1506

The Deller Consort, directed by Alfred Deller, whose incomparable counter-tenor voice is the highlight of the ensemble, has done much to promote the music of English composer Henry Purcell (c. 1659-1695), and that worthy task is continued with this record, which is primarily devoted to examples of Purcell's vocal music for the theater. The album will not be to everyone's taste but lovers of Purcell will want to hear it.



## Producer's Profile

Where does it all begin for a person like Ted Cooper who has, as a producer, chalked up twenty-three chart records in the last four years? Perhaps it was when he began studying violin at age four. Perhaps it was during his studies at Julliard School of Music, where he was the youngest student to ever be enrolled there. Perhaps it was...

In 1965 he joined Shapiro-Bernstein as general professional manager and it was there that he created Alice In Wonderful Productions. During his year at S.B. he produced such artists as the Flamingos, the Drifters, Dobie Gray and Leslie Uggams. The firm, that year, turned out over fifty chart records, including six which reached number 1 in England.

He went on to Epic Records where he was pop A&R head for three years. The first record he produced for the label was "Up Hill Climb To The Bottom" by Walter Jackson, which hit the charts. Eight other records by Jackson, also produced by Cooper, all hit the R&B and/or pop charts. They include "Corner In The Sun," "After You" written by Cooper, "Speak Her Name," "Tear For Tear" (also written by Cooper), and "Deep In The Heart Of Harlem." He produced Damita Jo's famous chart version of "If You Go Away," the song which was to become Rod McKuen's best known. He produced Vivian Reed's chart success, "Yours Until Tomorrow," which helped earn her a NATRA Award as Most Promising Female Artist. He produced The Third Rail's chart record, "Run, Run, Run." Other artists he produced for Epic include the Staple Singers, Major Lance, Maxine Brown and an LP with Godfrey Cambridge.



TED COOPER

He joined Mills Music in March, 1969 as vp. He created Double M Productions. He worked out a deal at Atlantic Records for Walter Jackson and recorded "Any Way That You Want Me" as Walter's first chart record for Cotillion. He also made a deal with Mercury to produce the Magnificent Men.

He left Mills in October, 1969 and formed a new association with Wes Farrell. He produced the Flamingos' single "Buffalo Soldier" on Polydor which went Top 10 R&B and Top 50's on pop. His latest production is "Mongoose" by The Elephant's Memory. Also, he's just finished the Flamingos' album and is working on the completion of the Elephant's Memory LP as well.

Perhaps that is where it all begins for a person like Ted Cooper.

# Alexenburg On Col. Promo Dept.

(Con't. from Page 7)

the action in one market, Detroit. Mark Lindsay's "Arizona," Billy Joe Royal's "Cherry Hill Park" and Pacific Gas & Electric's "Are You Ready" are other examples; and the label is now reseriving Johnny Mathis' "The Wherefore & The Why" because of a similar reception.

"The reseriving policy is another of our tools," Alexenburg points out. "We make a practice of sending out a reservice copy marked with a special label to avoid confusion, but these are kept to a minimum for particular

impact. The field men are provided a telegram explanation of the reason for reservice: areas that have the single showing, chart action, radio listings and the like. By holding down the number and calling special attention only to proven singles, the label has built a respect into its reservices."

If a record is strongly geared for one audience the promotion may be based on starting the song there, but Columbia's eye is always on moving a hit single into top forty. Consequently a Dyson, Chambers Brothers or O. C. Smith will gain exposure in as many radio formats as possible.

## Two-Way Information

On the initial release, Alexenburg will supply information about the direction in which a single is expected to be pushed. Decisions for the directive are arrived at by discussions with home office and field personnel. Based on reactions, he will then send regular directives about stations to contact and areas or outlets that have begun to move the single into other formats. This gives MOR singles the power to go top forty, R&B records a shot at teen sales and country product a chance to sell adult or top forty. "While it's comforting to have success with major acts, a tremendous amount of satisfaction is still in bringing about something with new artists. A first hit for a new act is excellent, but getting a million-seller for performers who are not teen attractions is the greatest feeling."

Supplementing the directives, Alexenburg is supplied with copies of correspondence between national, regional and branch representatives to stay on top of the situation developing for a record.

Each week is wrapped up by running down the radio status of the product and compiling a "master sheet" of all stations playing product, where the song is charted and how frequently he record is played. Separate tallies are compiled for top forty, R&B and country stations and these are on the desks of all field people Monday morning.

On the other side, Alexenburg is kept supplied with computer rundowns of sales figures with totals and regional breakdowns to reflect growth by area for various periods up to the present. These include LP's from which singles can be pulled using added information from radio playlist samplings.

"This gives us the power to follow through with sales by assuring that stock is supplied to cities where the material is played." It also allows Alexenburg and his associates to keep the trades and tip sheets aware of the course of a single or album on the sales level. Handling disbursement of this data are Steve Popovich, assistant director of national promotion; Jim Brown, manager of album promo; Sheila Chlanda, supervisor of promo administration; and Nashville based Gene Ferguson handling promotion of country product.

## Sam Goody Ups Sales Earnings

MASPETH, NEW YORK — Sam Goody, Inc. has the results of operations for the first quarter and twelve months ended March 31, 1970: Earnings for the initial 1970 period amounted to \$57,900, or \$.08 per share, calculated on 683,000 shares, as compared with \$55,084, or \$.08 per share on 650,000 shares, for the comparable interval in 1969. Sales of the company for the 1970 first quarter amounted to an initial period high of \$5,024,556, as compared with \$3,584,507 reported in the same 1969 period.

For the trailing twelve months ended March 31, 1970, sales amounted to \$17,670,832, as compared with \$14,579,813 recorded in the comparable twelve months through March 31, 1969. Earnings rose to \$623,072, or \$.94 per share, as compared with \$383,703, or \$.67 per share for the respective twelve months periods. The twelve months ended March 31, 1970 included extraordinary credits of \$.11 per share, while the preceding twelve months included a \$.03 per share extraordinary charge.

Per share results for the 1969 periods have been adjusted for the 2-for-1 stock split in December, 1969.

Sam Goody, president, noted that start-up costs in connection with establishment of the new wholesale division, as well as interest expenses incurred in financing the acquisition, prevented first quarter earnings from expanding further.

Goody indicated that the company's ninth retail store is scheduled for opening in Sept. 1970, in the regional King's Plaza Shopping Center in Brooklyn, New York, and that the company's tenth unit would be located in a large shopping center being constructed in Woodbridge, New Jersey, which is scheduled for completion in October, 1970.

Sam Goody, Inc., traded over-the-counter, presently operates a chain of eight retail audio and record stores. Through a wholly-owned subsidiary, Brun-International Recotape Corporation, the company is also engaged in the wholesale distribution of records, tapes and accessories.

## Cash Box DJ Poll

(Con't. from Page 7)

group is the Beatles; the orchestra category is led by Henry Mancini, while the most programmed instrumentalist is Ferrante & Teicher.

The winners in "most promising" are: Joe Cocker, Melanie, Jackson Five and Chicago (tie), El Chicano and Vincent Bell Orchestra.

### Country

The "most programmed" country single is "A Boy Named Sue" by Johnny Cash (Columbia), while the LP is "Johnny Cash at San Quentin" (Columbia). The other "most programmed" winners are: Johnny Cash (male vocalist), Tammy Wynette (female vocalist), Danny Davis & Nashville Brass (bands), Dolly Parton & Porter Wagoner (vocal groups), Chet Atkins (instrumentalist).

In the "most promising" category the winners are: Anthony Armstrong Jones (male vocalist), Connie Eaton (female vocalist), Gerry Smith (instrumentalists), Danny Davis & Nashville Brass (bands), Hagers (vocal group).

## Elektra 'Maturity'

(Con't. from Page 7)

ment and provide clearly defined functions. Also, major department heads are being given more time to expand their responsibilities within their scope. The label assigned George Steel to the company's New York office to assist national sales manager Mel Posner, who move into such areas as international sales. Bruce Harris, formerly involved solely in publicity, will handle both pr and advertising under the new look. Other revampings for key execs are in the works, too.

On the international level, Sue Roberts will continue to handle license deals and general business affairs; Clive Selwood is the company's manager in England, where the label is distributed through Pye.

Elektra is now housed in its new headquarters on the 13th floor of the Gulf & Western Building in New York.



THE MAN WITH NO NAME RIDES ON — Movie and TV bad guy Clint Eastwood received the red carpet treatment on arrival in Nashville Music City USA to record his first material for Certron Music Division. Among those on hand to greet him was Aubrey Mayhew, Certron chief. Clint's most recently completed film is "Beguiled".

## 'X' Marks Sales For Beverly Hills

HOLLYWOOD — Beverly Hills Records, via a long-term deal with movie producer-director Russ Meyer and his music coordinator for Meyer's "X" rated flicks, Igo Kantor, is releasing two new motion picture soundtrack albums "The Vixen" and "Cherry... & Harry... & Raquel".

Label prexy Morris I. Diamond, has labeled his June release "X" Marks the Spot - & Sales". A single from each soundtrack has already been released. Both scores were composed and arranged by William Loose.

## 45 rpm RECORDS oldies by mail

OLDIES from 1955 to 1969

All original artists  
For complete catalog send \$1.00  
(deductible from first order) to:

**BLUE NOTE SHOP**  
156 Central Ave., Albany, N.Y. 12206

## Don Kirshner believes in him.



# TOP HITS OF THE YEAR

A COMPILATION OF THE YEAR'S BIGGEST HITS TO DATE

Because Cash Box is continually asked to supply a list of the year's leading hits to A&R men, record producers and radio stations, etc., Cash Box offers a continuing feature that lists the year's Top 50 titles as of the date the feature appears. The feature is published in the last issue of each month and is compiled from the Cash Box Top 100 Sales Chart. Point system operates as follows: For each week a song is #1 on the Top 100 it receives 135 points. Each #2-record is awarded 124 points. No. 3 gets 123. No. 4 gets 122. No. 5 gets 121. From No. 6 thru No. 10 songs get 115 to 111 points respectively. No. 11 song gets 90 points and so on down the line till the No. 50 song which gets 51 points. Only the top fifty titles of any given week are included in the survey. Survey begins with the first issue in January.

	Total Points
1. Spirit In The Sky—Norman Greenbaum—Reprise	1417
2. ABC—Jackson 5—Motown	1415
3. Bridge Over Troubled Waters—Simon & Garfunkel—Columbia	1359
4. Venus—Shocking Blue—Colossus	1358
5. American Woman—Guess Who—RCA	1344
6. Let It Be—Beatles—Apple	1291
7. Raindrops Keep Falling On My Head—B.J. Thomas—Scepter	1244
8. Hey There Lonely Girl—Eddie Holman—ABC	1200
9. Instant Karma—John Ono Lennon—Apple	1171
10. No Time—Guess Who—RCA	1166
11. Something's Burning—Ken Rogers & First Edition—Reprise	1133
12. Thank You—Sly & The Family Stone—Epic	1128
13. Get Ready—Rare Earth—Rare Earth	1111
14. Reflections Of My Life—Marmalade—London	1109
15. I Want You Back—Jackson 5—Motown	1101
16. Turn Back The Hands Of Time—Tyrone Davis—Dakar	1096
17. Love Grows—Edison Lighthouse—Bell	1090
18. Rapper—Jaggerz—Kama Sutra	1089
19. Everything's Beautiful—Ray Stevens—Barnaby	1084
20. Which Way You Goin' Billy—Poppy Family—London	1071
21. Up Around The Bend—Creedence Clearwater Revival—Fantasy	1052
22. House Of The Rising Sun—Frijid Pink—Parrot	1036
23. Psychedelic Shack—The Temptations—Gordy	1016
24. Come And Get It—Bad Finger—Apple	1010
25. Easy Come Easy Go—Bobby Sherman—Metromedia	1005
26. Vehicle—Ides Of March—Warner Bros./7 Arts	990
27. For The Love Of Him—Bobbi Martin—U.A.	963
28. Without Love—Tom Jones—Parrot	961
28. Cecilia—Simon & Garfunkel—Columbia	961
29. Travelin Band—Creedence Clearwater Revival—Fantasy	957
30. Whole Lotta Love—Led Zeppelin—Atlantic	952
31. Love Or Let Me Be Lonely—Friends Of Distinction—RCA	952
32. The Letter—Joe Cocker—A&M	921
33. He Ain't Heavy He's My Brother—Hollies—Epic	915
34. Ma Belle Amie—Tee Set—Colossus	914
35. Make Me Smile—Chicago—Columbia	905
36. Arizona—Mark Lindsay—Columbia	897
37. Evil Ways—Santana—Columbia	886
38. I'll Never Fall In Love Again—Dionne Warwick—Scepter	881
39. Rainy Night In Georgia—Brook Benton—Cotillion	851
40. Didn't I Blow Your Mind This Time—Delfonics—Philly Groove	832
41. Don't Cry Daddy—Elvis Presley—RCA	810
42. Woodstock—Crosby Stills Nash Young—Atlantic	791
43. Love On A Two Way Street—Moments—Stang	777
44. Jam Up Jelly Tight—Tommy Roe—ABC	775
44. Daughter Of Darkness—Tom Jones—Parrot	775
45. Long And Winding Road—Beatles—Apple	774
46. Call Me—Aretha Franklin—Atlantic	771
47. Honey Come Back—Glen Campbell—Capitol	762
48. Jingle Jangle—The Archies—Kirshner	762



## Top 50 In R & B Locations

1 THE LOVE YOU SAVE Jackson 5 (Motown 1166)	1	26 SWEET FEELING Candi Staton (Fame 1466)	19
2 BALL OF CONFUSION Temptations (Gordy 7099)	3	27 LET THE MUSIC TAKE YOUR MIND Kool & The Gang (De-Lite 529)	34
3 IT'S ALL IN THE GAME Four Tops (Motown 1164)	2	28 STEALING IN THE NAME OF THE LORD Paul Kelly (Happy Tiger 541)	32
4 SPIRIT IN THE DARK Aretha Franklin (Atlantic 2731)	7	29 WHEN WE GET MARRIED Intruders (Gamble 4004)	39
5 STEAL AWAY Johnny Taylor (Stax 0068)	12	30 I WANT TO TAKE YOU HIGHER Ike & Tina Turner (Liberty 56177)	21
6 AIN'T THAT LOVIN' YOU Luther Ingram (KoKo 2105)	11	31 HAND CLAPPING SONG Meters (Josie 1021)	37
7 THE SLY, SLICK AND WICKED Lost Generation (Brunswick 55436)	8	32 YOU'VE BEEN MY INSPIRATION Main ingredient (RCA 0340)	36
8 MAYBE Three Degrees (Roulette 7079)	14	33 I'LL BE RIGHT HERE Tyrone Davis (Dakar 618)	38
9 LONELINESS/IF Manhattens (Deluxe 122)	15	34 FREEDOM BLUES Little Richard (Reprise 0907)	28
10 COLE, COOKE & REDDING/ SUGAR SUGAR Wilson Pickett (Atlantic 2722)	10	35 DEAR IKE Sisters & Brothers (Uni 55238)	35
11 THE END OF OUR ROAD/ME Marvin Gaye (Tamla 54195)	13	36 TIGHTER TIGHTER Alive & Kicking (Roulette 7078)	—
12 BROTHER RAPP (PT. 1) James Brown (King 6310)	4	37 THIS BITTER EARTH Satisfaction (Lionel 3201)	—
13 O-O-H CHILD Five Stairsteps (Buddah 165)	18	38 MAIL CALL TIME Mel & Tim (Bamboo 114)	43
14 LOVE ON A TWO WAY STREET The Moments (Stang 5012)	5	39 ARE YOU READY Pacific Gas & Electric (Columbia 45158)	—
15 WESTBOUND #9 Flaming Embers (Hot Wax 7033)	6	40 I GOTTA GET AWAY FROM MY OWN SELF Ray Godfrey (Spring 104)	40
16 CHECK OUT YOUR MIND Impressions (Curtom 1951)	9	41 GROOVY SITUATION Gene Chandler (Mercury 73083)	—
17 SHE DIDN'T KNOW Dee Dee Warwick (Atco 6154)	24	42 STAY AWAY FROM ME Major Lance (Curtom 1953)	—
18 BAND OF GOLD Freda Payne (Invictus 9075)	22	43 WATCH WHAT HAPPENS Lena Horne (Skye 4523)	44
19 LOVELAND Watts 103rd. St. Band (Warner Bros. 7365)	25	44 SOMETHING STRANGE IS GOIN' ON Ted Taylor (Ronn 44)	—
20 WHO'S GONNA TAKE THE BLAME Miracles (Tamla 54194)	23	45 ONE WAY TICKET TO NOWHERE Syl Johnson (Twilight 134)	—
21 SIGNED, SEALED, DELIVERED I'M YOURS Stevie Wonder (Tamla 54196)	29	46 PLEASE MAKE THE LOVE GO AWAY Whatnauts (Stang 5014)	47
22 TRYING TO MAKE A FOOL OUT OF ME Delfonics (Philly Groove 162)	27	47 LIFT EVERY VOICE & SING Kim Weston (Pride 1)	48
23 WHY CAN'T I TOUCH YOU Ronnie Dyson (Columbia 45110)	33	48 TWO LITTLE ROOMS Janet Lawson (UA 50671)	—
24 AND MY HEART SANG (TRA LA LA) Brenda & The Tabulations (Top & Bottom 403)	16	49 DROP BY MY PLACE Little Carl Carlton (Back Beat 613)	—
25 DON'T IT MAKE YOU WANNA GO HOME Brook Benton (Cotillion 44078)	17	50 BLACK FOX Freddy Robinson (Pacific Jazz 88155)	—



# insight&sound

## NEW YORK — COFFEE, TEA OR INFLATION

Last week Bill Graham wrote an open letter to agents and managers in the trade saying that the very existence of his Fillmore rock theaters is being threatened by the high prices of acts. His letter cited that no new acts have come along, that there is no longer any place for them to gain exposure, and that the big acts are making all the big money. In order for small acts to be exposed to the public a bigger act would necessarily have to be the drawing attraction, in any concert in which one of these smaller acts would appear. He says none of the big acts are letting themselves in to that. He also says that his places can't afford the asking prices of these bands, citing the large amounts of cash an act can take home by doing just one performance at a festival. Where will the next acts come from and how will they get the exposure necessary to gain them the success due them?

One of the places some of them will come from is the Bitter End Coffeehouse Circuit. Started three years ago by Fred Weintraub of the Bitter End Cafe, who has since gone on to a job at Warner Brothers, and Mike Brovsky, now president of the whole company called "Campus Directions", the organization has incorporated the whole company called Campus Directions, the organization has incorporated two hundred colleges from coast to coast into its talent circuit. Some thirty-five one week stints from one college's coffeehouse to another. All but 10% of their transportation is paid for by the colleges and they're put up at the expense of the colleges.

The acts play in the college coffeehouses. A coffeehouse consists of a room usually in the student union but always on campus. It's a university approved and sponsored function. Each college has total autonomy over its set-up, and therefore each coffeehouse is flexible to the needs of the campus. The students are charged around 50¢ or \$1.00 and in some cases it is free, sponsored entirely by the college. When a college agrees to get into the circuit, someone from the organization goes and sets up the light system, the sound system, and makes the room a total environment conducive to the artist as well as the student. Most of them have facilities for serving coffee, soda, snacks and a few of them offer alcoholic beverages.

At most of the colleges, coffeehouse week is a special event which takes place only one week out of each month, and during the preceding three weeks the college enters full scale into publicity by their own radio stations and newspapers. The whole campus gets involved with the act that is coming in.

Mike Brovsky calls the network "a workshop of entertainment. The act becomes something like the artist in residence of the classical period whereby he lives on campus in private housing — guest houses or motel: whatever the college has for them — and becomes part of the campus life." Some of the entertainers have been known to give lectures and attend classes. According to Brovsky, "For the artist the coffeehouse circuit becomes an outlet for an appreciative audience. It's a place for talent development. For the school the coffeehouse network provides the students a chance to have an entertainment workshop on campus, gives them a chance to know entertainers as people as opposed to stars, and its low budget is something that the school simply can afford."

What can the entertainer make on this circuit? Actually there's not that much money involved: a starting act can get anywhere from \$150 to \$200 and someone who has a record or has played the circuit for some time or has gained a lot of fame can get up to \$500 for a week.

(Con't. on page 38)

## HOLLYWOOD — ROCK PHOTOGRAPHY: A GROWING ART

"Rock photography," said Columbia's Michael Ochs recently, "is a rather undeveloped field." Pun aside, the art of capturing musical artists in a way that conveys some of the same aura as their music is only in its infant stages. There are several good rock photographers around these days, most of them connected in some way with Rolling Stone. They include **Baron Wolman** (who's now publishing "Rags," a contemporary culture fashion magazine), **Ed Careff** (who's so busy shooting album covers that he doesn't make the L.A. scene too often of late), **Jim Marshall** and, in N.Y., the super album cover champ, **Joel Brodsky**.

Our favorite photographers, who can be found anywhere there is rock music of merit, are **Sam Emerson** and **Tony Loew**, currently working together as "Emerson-Loew." We admire them as much for their persistence in freedom of movement at big rock concerts (no easy task) as for their pictures (which manage to capture the mood of the artist and the mood of the audience).

Sam, who worked at a taco stand and a car wash to get enough bread to subsidize his yen for photography, is a native Mississippian who majored in such subjects as accounting, business law, journalism and business management, before deciding to move to L.A. His pictures of the Rolling Stones' Altamont disaster, sold to Rock Magazine, brought him his first major success.

Tony, on the other hand, is a veteran of the record business, having served as West Coast regional promotion man for Kapp Records and local promoter for Record Merchandising and organized and ran a division of J.B.L. for four years before dropping out to become a photographer.

Sam and Tony, in their quest for pictures, kept running into each other at concerts. In their quest for sales, they kept running into each other at record company and P.R. offices. Also, everyone got them confused because of their hair. In March, they decided to try the first rock photographers merger on a limited basis. Their first job together was the Led Zeppelin concert, and it was their first big sale. Bill Yaryan, Atlantic's West Coast publicist, gave the boys a boost, and they now do most of Atlantic's picture work on the Coast. They've also become the

(Con't. on page 38)

Mungo Jerry/Johnny Winter  
Cissy Houston/Gulliver  
Anaheim Who concert through the lenses  
of Emerson-Loew (lower left)



**NEW YORK** (Cont'd. from page 38)

In the fall, the company plans to start an intermediate priced concert program which works on the same idea as the coffeehouse but in a concert format. The deal would be for one or two nights packaging one or two performers for each concert. Act might get from \$200 to \$1,500 for a concert. Again, it's something that the schools could afford, concerts that big agencies wouldn't bother to handle because of the money involved and it also gives the performer someplace to go after the coffeehouse circuit.

The Bitter End network is the only circuit of this nature in the country. Thirteen circuit coordinators handle the colleges in the various areas throughout the country. All the colleges are kept informed of what's happening by a monthly newsletter.

One of the other things in the works is a film circuit in which specialized films like an Incredible String Band concert film, or a film on woman's liberation could be passed around the circuit. A part of the plans call for a Movie Orgy which employs a concept of piecing together bits of film and sound for a six hour show that has no plot but a central theme, so that anyone could enter or leave during its running time and not miss anything.

The main thing about Campus Directions is that out of one office comes the management, booking and publishing facilities necessary for an act. The whole idea of the company is sound and is one of the most promising things to actually be working within the American folk and rock scene. Such artists as John Denver, Jerry Jeff Walker, McKendrie Spring, Keith Sykes, Townes Van Zandt and Don Crawford have been a part of the coffeehouse circuit and have gotten the proper exposure each of them needed from it. As a certain publicity director said about Mike Brovsky and his whole idea: "His head is in the right place." Maybe instead of going after the big, big money and the big, big bands, some other heads throughout the country could start turning in the right direction.

**fred holman**

**EAST COAST GIRL OF THE WEEK**

Would you call a Swedish girl who married an Italian a Swedish Meatball? Not if she was Karin Grasso of Tonsil Records, where she is a production assistant, sales person, bookkeeper, song publishing aide, etc. Married to BMI songwriter Richard Grasso of Beechwood Music, Karin is 25 years old. She says, though, that she's been in the record/entertainment business for a hundred years!

As a teenager she worked in her home town Miami with three dj's as Radio Girl, giving nightly reports on the Top 10 songs and the local scene. Upon graduation (two days after to be exact) she was on a plane to New York where she turned up a job as a dancer—something she had done in Miami. She was a "twister" at the Peppermint Lounge, The Roundtable, Trudy Heller's and other clubs around town. She also worked at free lance fashion modeling during what she calls her "ultra-skinny days" and appears on a few Blue Note album covers. For 3 years she worked as Roulette president Morris Levy's secy, and for 2½ years she held a job at Liberty. The opportunity came up late last year to work with a new record company from scratch and took it—Tonsil, started in January, 1970, and now has one LP and two singles. She loves her work and, between her hobbies of cooking and athletics, finds a few hours a day for it.



**SHORT TAKES**

When a group sits down to create a name that it can go under, the members must always have things to say about words and phrases that will be associated with it — complimentary or derogatory. **Gulliver**, a new group on Elektra, must have had fun thinking about record reviews that would say "... a group that stands tall" or "Watch for this one to travel way up the charts." The possibilities are endless depending on your familiarity with English literature (Jonathan Swift in particular) or your talent for making puns. While you mull over a few ideas on this matter, let me fill you in on the group. I mentioned their album several weeks ago and it is still one of my favorites to come from an American (Philadelphia in particular) group in a long time. They came up and rapped about how they recorded it to get such clarity on the recording. The quartet, composed of ex-music students, an ex-art student and an ex-transient apple picker/drive-in theatre attendant, have all worked among one of the three clics of Philadelphia studio men over the past two years. Together they have cut with The Electric Indian, Assembled Multitude and others. So, studio techniques are very familiar to them and the group uses them to their fullest to enhance their songs. And they say that the strongest thing working for them is each of their songs which are simple and flowing without a single unnecessary frill added. Harmonies and choice of instrumentation are tactfully chosen and worked out. The group says they go into the studio knowing what to do and go after a tight, full and coherent sound. The quietly amplified set-up of the studio makes it their creative workshop and the album they have produced is a masterpiece. It'll be out soon and the group will be promoting it on-stage. (I'll not end this item with a blasted pun about these potential giants.)

Two of the most promising happenings slated for the New York area this summer — **Mountindale** and the **New York Pop Concerts** — are beginning to turn less turn less promising each day. It seems that **Brave New World**, the producers of the NYPC, is forcing several top acts slated for both fests on the July 11 and 17 weekends to be withdrawn from the Mountindale bill because of a 100-mile/21-day exclusivity clause in the contracts they signed with various agencies. Mountindale is trying to replace the acts with others, and seems to be doing a good job of it considering the odds. This is one to keep an eye on. Meanwhile the only people who are really suffering from the rip-off are ticket holders who are anxious of

official photographers of Concert Associates, California's leading promoters. In addition to album covers, concerts and P.R. pictures, Emerson-Loew are also working with writer Kathy Orloff on some stories.

The pictures on the lower two-thirds of this page were all shot at the Who concert at Anaheim Stadium, and represent rock photography at its best.

**allan rinde**

**LOUIE, LOUIE** "As long as those pearly teeth hold out, Louie'll still be playing something new, and all the others will be running after him, trying to catch up." (Jazz pianist **Richard M. Jones**)

If anyone should ask we'd say that **Louie Armstrong, Duke Ellington** and **Benny Goodman** are the Bach, Beethoven and Brahms of jazz. And if we had to name one guy alone, we'd give Louis the title as the greatest jazz personality ever to raise a horn to his lips and blast a rooftop.

Armstrong is 70 years old — today. He has been blowing into a trumpet (and cornet) for nearly 60 out of those 70 barrelhouse years. The history books tell us that he started in New Orleans, fooling around with a beatup trumpet and trying it on for size. He was twelve when he was sentenced to the Waif's home for "firing firearms within the city limits." And it was there that he learned to read music.

By 1917 he was playing in the excursion boats that moved up the Mississippi's muddy waters. By 1922 he was a member of King Oliver's band at the Lincoln Garden in Chicago. And two years later he was the star attraction with Fletcher Henderson's band at the Roseland in N.Y. By 1927 he had moved into the Sunset Cafe with his own band. But Louis was always — and will always be — the main attraction. So eloquent, so unique that kids who had jazz within them came nightly to listen in awe-struck devotion. Kids who were screwballs at the time — **Muggsy Spanier, Bing Crosby, Frank Teschmacher, Bix Beiderbecke, Jess Stacy** and **Benny Goodman**.

What Armstrong did those nights at the Sunset he is still doing. And if he occasionally hams it up a bit, we understand. It was in the mid-thirties when Hollywood finally discovered him — handed him a scene or two in a Crosby flick ("Pennies From Heaven") and Louis became a kind of clown. And in "Going Places" he crooned **Johnny Mercer's** "Jeepers Creepers" (where'd you get those peepers?) to a horse. Louis probably came off best in "New Orleans," a film based loosely on his life. To our recollection it was (and probably still is) the most authentic jazz incorporated into a film score.

Now he can be caught on TV occasionally, guesting on shows helmed by far lesser talents than him. And in Europe, where he is revered, he'll tour to standing room only crowds with pick up all star combos. Soon he'll be in town, we hear, to celebrate his 70th with us, concertizing and compelling.

This then (since we don't have his home address) is our open-adoration birthday greeting to the King. Stick with the Swiss Kriss, man. Happy 70th.

A post-script on Ellington (also celebrating his 70th this year) who is currently represented with a two pocket Solid State (Transamerica) LP, cut in Manchester, England last November. We heard the LP just this morning. And we're planning to take it to bed tonight. To our ears they're the best Ellington sides since he left Victor... and that's a long long time.

**AND HOWE** — Last week's announcement that **Macey Lipman** and **Bones Howe** had joined forces to form a new production firm (Mr. Bones Productions), we hear, has been in the works for months. As a matter of fact songsmith **Norman Gimbel** mentioned it to us when we were in N.Y. in April. "It's not definite," said Norman. "I called Macey the other day but he refused comment." Another case of Macey not telling Gimbel — no?

**harvey geller**

**CHICAGO**

Enjoyed a delightful visit with Steed songster **Andy Kim**, who was in Chicago for a couple of days last week following his smash performance at the Milwaukee Pop Festival. In addition to recording a new single "It's Your Life", Andy's been quite busy on the p.a. front with appearances on the **Barbara MacNair Show**, a co-hosting stint on the popular Upbeat TV'er and presiding over Andy Kim Day in Montreal. He's due back this way in August to appear at the Illinois State Fair in Springfield... **Dick Sarlo** of the Pick Congress Hotel has formed Sarlo Enterprises Inc. and will be booking a series of concerts in Chicago, geared to the adult ticket buyer. Opening bill, scheduled for Sept. 18-19 in Orchestra Hall, will spotlight **Jimmy Rosselli** and **Corbett Monica**. **Paul Gallis** will be handling p.r. for the new firm... WB's promo rep **Roy Chiovari** is working on the newly released **Dion** single "Your Own Back Yard", which has an anti-drugs theme... Two very important local personalities were farewell parted last week: Chicago Today columnist **Charlie Dawn**, who covered the night club beat in town for the past 40 years; and pianist **Eddie Higgins**, formerly of London House, who's departing for Florida... Liberty-UA's promo man **Paul Diamond**, cut some commercials for airing on WSDM... **Brownsville Station** have a new single on Paladium, coupling "Bebop Confidential" with "City Life". Personal manager **Al Nalli** (A&A Productions) says the group has a heavy schedule of personal appearances to fulfill and will be playing several of the major festivals across the country... Songstress **Sylvia Syms** and comedian **George McKelvey** will be opening in Mister Kelly's 6/29 for three weeks... **The Four Freshmen** are scheduled for the local Playboy Club August 17-29... The July 3-4 bill at the Aragon will feature the **Grateful Dead**, **It's Beautiful Day**, **Aum** and **Rare Bird**... **Tony Bennett** headlines the Villa Scalabrini benefit in the Opera House 8/15... The Empire Room will discontinue its entertainment format for the summer, following **John Davidson's** current two weeks engagement.

the outcome. Please, people, try to get it together. Your time here is too short to create such unnecessary bummers. I'm beginning to agree with Bill Graham that big business is on the verge of killing the whole big business.

Jug band group from England, **Mungo Jerry**, is really on fire in that country with their act and their single, "In The Summertime," which hit No. 1 overnight. Janus Records has released that song here... **Johnny Winter** will play with his new group at The Playground on Long Island on July 4. Group includes Rick Deringer on guitar and vocals, Randy Hobbs on bass and vocals, Randy Z on drums and Johnny on the usual... Commonwealth-United's **Cissy Houston** was among the acts for the last taping of this season's NET "Soul" show... **Dave Van Ronk**, newly signed with Polydor, into the Gaslight July 1-4... The **Modern Jazz Quartet** opens a two week stand at the Rainbow Grill June 29.

# Vital Statistics

DETAILED INFORMATION ABOUT TITLES ON THE CASH BOX TOP 100 THIS WEEK

*New To The Top 100			
<p><b>#1</b> <b>THE LOVE YOU SAVED (2:42)</b> <b>Jackson Five-Motown 1166</b> 2457 Woodward Ave. Detroit, Mich. PROD: The Corporation c/o Motown PUB: Jobete BMI (same address) FLIP: I Found That Girl</p>	<p><b>#15</b> <b>ASONG OF JOY (4:45)</b> <b>Miguel Rios-A&amp;M 1193</b> 1416 N La Brea, L.A. Calif. PROD: By Hispavox PUB: Barnegat BMI c/o U.A. 729 7th Ave, NYC. WRITERS: Orbe-W. DeLosrios FLIP: El Rio</p>	<p><b>#29</b> <b>SILVER BIRD (3:05)</b> <b>Mark Lindsay-Columbia 45180</b> 51 West 52 St. NYC. PROD: Jerry Fuller c/o Columbia PUB: Kangaroo BMI 225 E 63 St. NYC. WRITER: K. Young ARR: Artie Butler FLIP: So Hard To Leave You</p>	<p><b>#43</b> <b>DAUGHTER OF DARKNESS (3:18)</b> <b>Tom Jones-Parrot 40048</b> 539 West 25 St. NYC. PROD: Peter Sullivan for Gordon Mills 24-25 New Bond St. London W1 England. PUB: Felsted BMI 539 W. 25 St. NYC. WRITERS: Les Reed-Geoff Stephens ARR: Les Reed FLIP: Tupelo Mississippi Flash</p>
<p><b>#2</b> <b>MAMA TOLD ME NOT TO COME (2:58)</b> <b>Three Dog Night-Dunhill 4239</b> 8255 Beverly Blvd. L.A. Calif. PROD: Richie Podolor c/o American Studios 11386 Ventura Blvd. Sherman Oaks, Calif. PUB: January BMI 25 W 56 St. NYC. WRITER: Randy Newman FLIP: Rock And Roll Widow</p>	<p><b>#16</b> <b>OOH OOH CHILD (3:11)</b> <b>Five Steps-Buddah 165</b> 1650 Bway, NYC. PROD: Stan Vincent 300 W 55 St. NYC. PUB: Duckstein/Kama Sutra BMI c/o Buddah WRITER: S. Vincent FLIP: Who Do You Belong To</p>	<p><b>#30</b> <b>WESTBOUND #9 (2:53)</b> <b>Flaming Ember-Hot Wax 7003</b> c/o Buddah 1650 Bway, NYC. PROD: Stage Coach 2601 Cadillac Tower, Det. Mich. PUB: Gold Forever BMI c/o Stage Coach WRITERS: D. Dumas-R. Dunbar-E. Wayne FLIP: Why Don't You Stay</p>	<p><b>#44</b> <b>STEAL AWAY (3:15)</b> <b>Johnnie Taylor-Stax 0068</b> 926 E. McLamore, Memphis, Tenn. PROD: Don Davis c/o Stax PUB: Fame BMI P. O. Box 2238 Muscle Shoals, Ala. WRITER: Jimmy Hughes FLIP: Friday Night</p>
<p><b>#3</b> <b>BALL OF CONFUSION (4:04)</b> <b>Temptations-Gordy 7099</b> 2457 Woodward Ave. Detroit, Mich. PROD: Norman Whitfield c/o Gordy PUB: Jobete BMI (same address) WRITERS: Whitfield-Strong FLIP: It's Summer</p>	<p><b>#17</b> <b>LOVELAND (3:02)</b> <b>Watts 103rd St. Band-Warner Bros. 7365</b> 4000 Warner Blvd. Burbank, Calif. PROD: Chas. Wright c/o Wright Gerstele PUB: Wright Gerstele BMI 488 Mad. Ave. NYC. Tamarlane BMI 6290 Sunset Blvd. L.A. Calif. WRITERS: Trotter-Wright FLIP: Sorry Charlie</p>	<p><b>#31</b> <b>TIGHTER AND TIGHTER (2:45)</b> <b>Alive &amp; Kicking-Roulette 7078</b> 17 W 60 St. NYC. PROD: T. James-B. King c/o Mark Allan 300 W 55 St. NYC. PUB: Big Seven BMI c/o Roulette WRITERS: T. James-B. King ARR: Jimmy Wisner FLIP: Sunday Morning</p>	<p><b>#45</b> <b>TRYING TO MAKE A FOOL OF ME (2:58)</b> <b>Delfonics-Philly Groove 162</b> c/o Bell 1776 Bway, NYC. PROD: Stan &amp; Bell 250 S Broad St. Phila, Pa. PUB: Nickle Shoe BMI c/o Stan &amp; Bell WRITERS: Thom Bell-Wm. Hart ARR: T. Bell FLIP: Baby I Love You</p>
<p><b>#4</b> <b>LAY DOWN (CANDLES IN THE RAIN) (3:49)</b> <b>Melanie-Buddah 167</b> 1650 Bway, NYC. PROD: Peter Schnekerky c/o Buddah PUB: Kama Rippa/Amelanie ASCAP (same address) WRITER: Melanie Safka FLIP: Candles In The Rain</p>	<p><b>#18</b> <b>CLOSE TO YOU (3:40)</b> <b>Carpenters-A&amp;M 1183</b> 1416 N La Brea, L.A. Calif. PROD: Jack Dougherty c/o A&amp;M PUB: U.S. Songs BMI c/o Quartet ASCAP 1619 Bway, NYC. WRITERS: Hal David-Burt Bacharach ARR: Richard Carpenter FLIP: I Keep On Loving You</p>	<p><b>#32</b> <b>GO BACK (3:08)</b> <b>Crabby Appleton-Elektra 45687</b> 1655 Bway, NYC. PROD: Don Gallucci c/o Elektra PUB: Mee Moo BMI 9220 Sunset Blvd. L.A. Calif. WRITER: M. Fennelly FLIP: Try</p>	<p><b>#46</b> <b>I JUST CAN'T HELP BELIEVING (2:57)</b> <b>B. J. Thomas-Scepter 12283</b> 254 W 54 St. NYC. PROD: Chips Moman 827 Thomas St. Memphis, Tenn. PUB: Screen Gems/Columbia BMI 711 5th Ave. NYC. WRITERS: Mann-Weil ARR: Glen Spreen-Mike Leech FLIP: Send My Picture To Scranton, Pa.</p>
<p><b>#5</b> <b>RIDECAPTAIN RIDE (3:06)</b> <b>Blues Image-Atco 6746</b> 1841 Bway, NYC. PROD: Richard Podolor for Big Foot Prod. PUB: ATM ASCAP WRITERS: Blues Image ARR: Blues Image FLIP: Pay My Dues</p>	<p><b>#19</b> <b>QUESTION (4:55)</b> <b>Moody Blues-Threshold 67004</b> c/o London 539 West 25 St. NYC. PROD: Tony Clarke 8 Rathbone Pl. London W1 Eng. PUB: TRO-Andover ASCAP 10 Columbus Circle, NYC. WRITER: Hayward FLIP: Candle Of Life</p>	<p><b>#33</b> <b>THE LETTER (4:10)</b> <b>Joe Cocker-A&amp;M 1174</b> 1416 N La Brea, L.A. Calif. PROD: Denny Cordell-Leon Russell c/o A&amp;M PUB: Earl Barton BMI 1121 S. Glenstone, Springfield, Mo. WRITERS: Wayne-Carson-Thompson FLIP: Space Captain</p>	<p><b>#47</b> <b>THAT SAME OLD FEELING (2:56)</b> <b>Picketty Witch-Janus 118</b> 1700 Bway, NYC. PROD: John Macleod c/o Fye, ATV House, London, England PUB: January BMI 25 W 56 St. NYC. WRITERS: J. Macleod-T. MacAulay FLIP: Maybe We've Been Loving Too Long</p>
<p><b>#6</b> <b>HITCHIN' A RIDE (2:37)</b> <b>Vanity Fare-Page One 21029</b> 1776 Bway, NYC. PROD: Roger East Jerry &amp; DesChamp London, England. PUB: Intune Inc. BMI 666 5th Ave. NYC WRITERS: Mitch Murray-Peter Callander FLIP: Man Child</p>	<p><b>#20</b> <b>IT'S ALL IN THE GAME (2:49)</b> <b>Four Tops-Motown 1164</b> 2457 Woodward Ave. Detroit, Mich. PROD: Frank Wilson c/o Motown PUB: Remick ASCAP 488 Madison Ave, NYC. WRITERS: Dawes-Sigman ARR: Jerry Long-Jimmy Roach FLIP: Love Is The Answer</p>	<p><b>#34</b> <b>CANNED HAM (2:47)</b> <b>Norman Greenbaum-Reprise 0910</b> 4000 Warner Blvd. Burbank, Calif. PROD: Erik Jacobson c/o Reprise PUB: Great Honesty BMI 1414 6th Ave, NYC. WRITER: Norman Greenbaum FLIP: Junior Cadillac</p>	<p><b>#48</b> <b>EVERYTHING'S BEAUTIFUL (3:29)</b> <b>Ray Stevens-Barnaby 72011</b> c/o Columbia 51 W 52 St. NYC. PROD: Ray Stevens for AHAB PUB: AHAB BMI Meadowgreen Dr. Franklin, Tenn. WRITER: Ray Stevens FLIP: A Brighter Day</p>
<p><b>#7</b> <b>GET READY (2:46)</b> <b>Rare Earth-Rare Earth 5012</b> c/o Motown 2457 Woodward Ave. Detroit, Mich. PUB: Jobete BMI (same address) WRITER: W. Robinson FLIP: The Magic Key</p>	<p><b>#21</b> <b>TEACH YOUR CHILDREN (2:53)</b> <b>Crosby, Stills, Nash, Young-Atlantic 2735</b> 1841 Bway, NYC. PROD: Crosby, Stills, Nash, Young c/o Atlantic PUB: Giving Room BMI WRITER: Graham Nash FLIP: Carry On</p>	<p><b>#35</b> <b>LOVE ON A TWO WAY STREET (3:05)</b> <b>Moments-Stang 5012</b> 106 W. Palisades Ave, Engelwood, N.J. PROD: Sylvia (same address) PUB: Gambi BMI (same address) WRITERS: Sylvia Robinson-B. Keyes FLIP: I Won't Do Anything</p>	<p><b>#49</b> <b>SWEET FEELING (2:45)</b> <b>Candi Staton-Fame 1466</b> c/o Capitol 1740 N Vine, L.A. Calif. PROD: Rick Hall c/o Fame PUB: Fame BMI c/o Harry Fox 110 E 59 St. NYC. WRITERS: Carter-Hall-Daniel-Staton FLIP: Evidence</p>
<p><b>#8</b> <b>LONG AND WINDING ROAD (3:40)</b> <b>Beatles-Apple 2832</b> 1700 Bway, NYC. PROD: Phil Spector 9130 Sunset Blvd. L.A. Cal. PUB: MacLen BMI 1780 Bway, NYC. WRITERS: John Lennon-Paul McCartney FLIP: For You Blue</p>	<p><b>#22</b> <b>SUGAR SUGAR (3:45)</b> <b>Wilson Pickett-Atlantic 2722</b> 1841 Bway, NYC. PROD: J. Wexler-T. Dowd c/o Atlantic PUB: Kirshner BMI 655 Mad. Ave. NYC. WRITERS: Jeff Barry-Andy Kim ARR: Wm. Fischer</p>	<p><b>#36</b> <b>SO MUCH LOVE (3:03)</b> <b>Faith Hope &amp; Charity-Maxwell 805</b> 1655 Bway, NYC. PROD: Van McCoy BMI 341 N. Woodland St. Engelwood, N.J. WRITERS: Van McCoy-Joe Cobb FLIP: Let's Try It Over</p>	<p><b>#50</b> <b>UP AROUND THE BEND (2:38)</b> <b>Creedence Clearwater Revival-Fantasy 641</b> 1281 30th St. Oakland, Calif. PROD: John Fogerty c/o Fantasy PUB: Jondora BMI c/o Fantasy WRITER: J. Fogerty ARR: J. Fogerty FLIP: Run Through The Jungle</p>
<p><b>#9</b> <b>BAND OF GOLD (2:50)</b> <b>Freda Payne-Invictus 9075</b> 2601 Cadillac Tower, Detroit, Mich. PROD: Holland-Dozier-Holland c/o Invictus PUB: Gold Forever BMI (same address) WRITERS: R. Dunbar-B. Wayne FLIP: The Easiest Way To Fall</p>	<p><b>#23</b> <b>SIGNED SEALED DELIVERED I'M YOURS (2:45)</b> <b>Stevie Wonder-Tamla 54196</b> 2457 Woodward Ave. Detroit, Mich. PROD: Stevie Wonder c/o Tamla PUB: Jobete BMI (same address) WRITERS: S. Wonder-L. Garrett-S. Wright-L. Hardaway ARR: Paul Riser FLIP: I'm More Than Happy</p>	<p><b>#37</b> <b>HEY MISTER SUN (2:32)</b> <b>Bobby Sherman-Metromedia 188</b> 1700 Bway, NYC. PROD: Jackie Mills 6430 Sunset Blvd. L.A. Calif. PUB: Green Apple BMI c/o Jackie Mills WRITER: D. Janssen ARR: Al Capps FLIP: Two Blind Minds</p>	<p><b>#51</b> <b>COME SATURDAY MORNING (2:57)</b> <b>Sandpipers-A&amp;M 1185</b> 1416 N La Brea, L.A. Calif. PROD: Allen Stanton c/o A&amp;M PUB: Famous ASCAP 6290 Sunset Blvd. L.A. Cal. WRITERS: Dor Previn-Fred Karlin ARR: Nick DeCaro FLIP: Pretty Flamingo</p>
<p><b>#10</b> <b>THE WONDER OF YOU (2:37)</b> <b>Elvis Presley-RCA 9835</b> 1133 Ave. of the Americas, NYC. PUB: Duchess BMI c/o MCA 445 Park Ave, NYC. WRITER: Baker Knight ARR: Glenn D. Hardin FLIP: Mama Liked The Roses</p>	<p><b>#24</b> <b>OHIO (3:00)</b> <b>Crosby Stills Nash Young-Atlantic 2740</b> 1841 Bway, NYC. PROD: Crosby Stills Nash Young c/o Atlantic PUB: Cotillion BMI c/o Atlantic Broken Arrow BMI 449 S Bev. Dr. Bev. Hills, Calif. WRITER: Neil Young FLIP: Find The Last Of Freedom</p>	<p><b>#38</b> <b>THE END OF THE ROAD (2:48)</b> <b>Marvin Gaye-Tamla 54195</b> 2457 Woodward Ave. Detroit, Mich. PROD: Norman Whitfield c/o Tamla PUB: Jobete BMI (same address) WRITERS: Whitfield-Strong-Penzabene FLIP: Me And My Lonely Room</p>	<p><b>#52</b> <b>MAKE ME SMILE (2:58)</b> <b>Chicago-Columbia 45127</b> 51 West 52 Street, NYC. PROD James Wm Guercio c/o Columbia PUB: Aurelius BMI 7781 Sunset Blvd. L.A. Cal. WRITER: J. Pankow FLIP: Colour My World</p>
<p><b>#11</b> <b>WHICH WAY YOU GOIN' BILLY? (3:10)</b> <b>Poppy Family (featuring Susan Jacks)</b> <b>London 129</b> 539 W 25 St. NYC. PROD: T. Jacks 150-24 St. Suite 705 W. Vancouver B.C. Canada PUB: Gone Fishin BMI WRITER: T. Jacks FLIP: Endless Sleep</p>	<p><b>#25</b> <b>ARE YOU READY (5:49)</b> <b>Pacific Gas &amp; Elec Co-Columbia 45158</b> 51 West 52 St. NYC. PROD: John Hill c/o Columbia PUB: Pacific Gas &amp; Elec Co. c/o Pilger Dubay Co. 1180 S Bev. Dr. L.A. Calif. Hexagram BMI WRITERS: C. Allen-J. Hill FLIP: Staggolee</p>	<p><b>#39</b> <b>MAKE IT WITH YOU (3:14)</b> <b>Bread-Elektra 45686</b> 15 Columbus Circle, NYC. PROD: David Gates c/o Elektra PUB: Screen Gems/Columbia BMI 711 5th Ave, NYC. WRITER: D. Gates FLIP: Why Do You Keep Me Waiting</p>	<p><b>#53</b> <b>MY MARIE (3:05)</b> <b>Engelbert Humperdinck-Parrot 40049</b> 539 W 25 St. NYC. PROD: Peter Sullivan for Gordon Mills 24-25 New Bond St. London W1 England. PUB: January BMI 25 W 56 St. NYC. WRITERS: Macaulay-Mason FLIP: Our Song (La Paloma)</p>
<p><b>#12</b> <b>MY BABY LOVES LOVIN' (2:38)</b> <b>White Plains-Deram 85058</b> 539 West 25th Street, NYC. PROD: Roger Greenway-Roger Cook (England) PUB: Maribus BMI 1780 Bway, NYC. WRITERS: Cook-Greenway FLIP: Show Me Your Hand</p>	<p><b>#26</b> <b>CHECK OUT YOUR MIND (3:20)</b> <b>Impressions-Curtom 1951</b> c/o Buddah 1650 Bway, NYC. PROD: Curtis Mayfield 8543 Stoney Island Ave, Chi. Ill. PUB: Camad BMI c/o Curtis Mayfield WRITER: C. Mayfield FLIP: Can't You See</p>	<p><b>#40</b> <b>MISSISSIPPI (2:59)</b> <b>John Philips-Dunhill 4236</b> 8255 Beverly Blvd. L.A. Cal. PROD: Lou Adler c/o Ode 1416 N La Brea, L.A. Cal. PUB: Alchemy ASCAP 9777 Wilshire Blvd. L.A. Cal. WRITER: J. Philips ARR: J. Philips FLIP: April Anne</p>	<p><b>#54</b> <b>LAY A LITTLE LOVIN' ON ME (3:04)</b> <b>Robin McNamara-Steed 724</b> Guif &amp; Western Plaza, Col. Circle, NYC. PROD: Jeff Barry c/o Unart PUB: Unart BMI 729 7th Ave, NYC. WRITERS: Jeff Barry-J. Cretecos-R. McNamara FLIP: I'll Tell You Tomorrow</p>
<p><b>#13</b> <b>UNITED WESTAND (2:54)</b> <b>Brotherhood Of Man-Deram 85059</b> 539 West 25 St. NYC. PROD: Tony Hiller c/o Belwin Mills 20 Denmark St., London WC2, England. PUB: Belwin Mills ASCAP 16 W 61 St. NYC. WRITERS: Tony Hiller-Peter Simons ARR: Cy Payne FLIP: Say A Prayer</p>	<p><b>#27</b> <b>MISSISSIPPI QUEEN (2:30)</b> <b>Mountain-Windfall 532</b> 1776 Bway, NYC. PROD: Felix Pappalardi 161 W 54 St. NYC. PUB: Uptall ASCAP 161 W 54 St. NYC. WRITERS: West-Laing-Pappalardi-Rea ARR: F. Pappalardi FLIP: The Laird</p>	<p><b>#41</b> <b>I WANT TO TAKE YOU HIGHER (2:55)</b> <b>Sly &amp; Family Stone-Epic 10450</b> 51 West 52 St. NYC. PROD: Sly Stone for Stone Flower 700 Urbano St. San Francisco, Calif. PUB: Daly City BMI 221 W 57 St. NYC. WRITER: S. Stewart ARR: Sly &amp; Family Stone FLIP: Stand</p>	<p><b>#55</b> <b>MAYBE (4:06)</b> <b>Three Degrees-Roulette 7079</b> 17 W 60 St. NYC. PROD: Richard Barrett c/o Roulette PUB: Nom BMI (same address) WRITER: R. Barrett ARR: Swanson-Barrett FLIP: Collage</p>
<p><b>#14</b> <b>GIMME DAT DING (2:10)</b> <b>Pipkins-Capitol 2819</b> 1750 N Vine, L.A. Calif. PROD: John Burgess c/o Capitol PUB: Duchess BMI 445 Park Ave, NYC. WRITERS: Hammond-Hazlewood ARR: Jim Sullivan FLIP: To Love You</p>	<p><b>#28</b> <b>SAVE THE COUNTRY (2:39)</b> <b>5th Dimension-Bell 895</b> 1776 Bway, NYC. PROD: Bones Howe 8833 Sunset Blvd. L.A. Calif. PUB: Tuna Fish BMI 1650 Bway, NYC. WRITER: Laura Nyro ARR: Alcivar-Holman-Howe FLIP: Dimension 5</p>	<p><b>#42</b> <b>SPIRIT IN THE DARK (2:58)</b> <b>Aretha Franklin-Atlantic 2731</b> 1841 Bway, NYC. PROD: Jerry Wexler-Tom Dowd-Arif Mardin c/o Atlantic PUB: Pundit BMI WRITER: Aretha Franklin FLIP: The Thrill Is Gone</p>	<p><b>#56*</b> <b>BOYS IN THE BAND (2:59)</b> <b>Boys In The Band-Spring 103</b> c/o Polydor 1700 Bway, NYC. PROD: Bob Feldman-Hierman Griffin for Fireplace, 1619 Bway, NYC. PUB: Yellow Dog ASCAP 477 Mad. Ave. NYC. WRITERS: Jerry Leiber-Mike Stoller FLIP: Sumpin Heavy</p>

# Vital Statistics

DETAILED INFORMATION ABOUT TITLES ON THE CASH BOX TOP 100 THIS WEEK

**\*New To The Top 100**

**#57**  
**SPILL THE WINE (3:59)**  
**Eric Burdon & War-MGM 14118**  
1350 Ave of the Americas, NYC.  
PROD: Jerry Goldstein c/o MGM  
PUB: New Film BMI c/o Ernest Pintoff  
130 E 75 St, NYC.  
WRITERS: War FLIP: Magic Mountain

**#58**  
**SHE CRIED (3:12)**  
**The Lettermen-Capitol 2820**  
1750 N Vine, L.A. Calif.  
PROD: Al DeLory c/o Capitol  
PUB: Trio BMI 1619 Bway, NYC.  
WRITERS: G. Richards-T. Daryl FLIP: For Love

**#59**  
**IF YOU LET ME MAKE LOVE TO YOU,  
THEN WHY CAN'T I TOUCH YOU (3:26)**  
**Ronnie Dyson-Columbia 45110**  
51 West 52 St, NYC.  
PROD: Billy Jackson c/o Columbia  
PUB: Chappell ASCAP 609 5th Ave, NYC.  
WRITERS: C.C. Courtney-P. Link  
FLIP: Girl Don't Come

**#60**  
**PEARL (2:55)**  
**Tommy Roe-ABC 11266**  
8255 Bev. Blvd. Bev. Hills, Calif.  
PROD: Steve Barri c/o ABC  
PUB: Low Tvi BMI c/o Bill Lowery  
P. O. Box 9687 Atlanta, Ga.  
WRITERS: T. Roe-Freddie Weller ARR: Jimmie Haskell  
FLIP: Dollars Worth Of Pennies

**#61**  
**QUE SERA SERA (3:04)**  
**Mary Hopkin-Apple 1823**  
1700 Bway, NYC.  
PROD: Paul McCartney c/o Apple  
PUB: Artist ASCAP  
250 N. Canon Dr. Bev. Hills, Calif.  
WRITER: Livingston-Evans  
FLIP: Fields Of St. Etienne

**#62**  
**SUNSHINE (2:56)**  
**Archies-Kirshner 1009**  
655 Madison Ave, NYC.  
PROD: Jeff Barry 729 7th Ave, NYC.  
PUB: Don Dirshner BMI (same address)  
WRITERS: Jeff Barry-Bobby Bloom  
ARR: Jeff Barry FLIP: Over And Over

**#63**  
**SUPERMAN (2:57)**  
**Ides Of March-Warner Bros 7403**  
4000 Warner Blvd. Burbank, Calif.  
PROD: Frank Rand-Bob Destacki c/o WB  
PUB: Ides BMI 185 N. Wabash, Chicago, Ill.  
WRITER: Jim Peterik FLIP: Home

**#64**  
**I'LL BE RIGHT HERE (2:41)**  
**Tyrone Davis-Dakar 618**  
1841 Bway, NYC.  
PROD: Willie Henderson c/o Dakar  
PUB: Julio Bryon BMI Judon BMI  
WRITERS: J. Daniels-J. Moore  
ARR: Tom Tom Washington  
FLIP: Just Because Of You

**#65**  
**COME TO ME (2:31)**  
**Tommy James & Shondells-Roulette 7074**  
17 W 60 St, NYC.  
PROD: T. James-Bob King c/o Mark Alan  
300 W 55 St, NYC.  
PUB: Big Seven BMI c/o Roulette  
WRITERS: T. James-B. King ARR: Jimmy Wisner  
FLIP: Talkin' And Signifyin'

**#66**  
**A LITTLE BIT OF SOAP (2:30)**  
**Paul Davis-Bang 576**  
1650 Bway, NYC.  
PROD: Eileen Burns-Paul Davis c/o Bang  
PUB: Mellin BMI (same address)  
WRITER: Bert Burns FLIP: Three Little Words

**#67**  
**DON'T IT MAKE YOU WANNA GO HOME (3:20)**  
**Brook Benton-Cotillion 44078**  
1841 Bway, NYC.  
PROD: Arif Mardin c/o Cotillion  
PUB: Lowery BMI P. O. Box 9687 Atlanta, Ga.  
WRITER: Joe South ARR: Arif Mardin  
FLIP: I've Gotta Be Me

**#68**  
**NO ARMS CAN EVER HOLD YOU (2:34)**  
**Grass Roots-Dunhill 4237**  
8255 Beverly Blvd. L.A. Calif.  
PROD: Steve Barri c/o Dunhill  
PUB: Truesdale BMI c/o Dunhill  
WRITERS: H. Price-D. Walsh  
ARR: Jimmie Haskell FLIP: Get It Together

**#69**  
**AIN'T THAT LOVIN' YOU (3:20)**  
**Luther Ingram-Koko 2105**  
c/o Stax 926 E. McLemore, Memphis, Tenn.  
PROD: Johnny Baylor c/o Stax  
PUB: E. Memphis BMI (same address)  
WRITERS: A. Jones-H. Banks  
FLIP: Home Don't Seem Like Home

**#70**  
**OVERTURE FROM TOMMY (2:30)**  
**Assembled Multitude-Atlantic 2737**  
1841 Bway, NYC.  
PROD: Bill Buster c/o Atlantic  
PUB: Track BMI 200 W 57 St, NYC.  
WRITER: Peter Townhend ARR: Tom Sellers  
FLIP: Mud

**#71**  
**GIVE A WOMAN LOVE (3:02)**  
**Bobbi Martin-U.A. 50687**  
729 7th Ave, NYC.  
PROD: Henry Jerome c/o U.A.  
PUB: U.A. ASCAP 729 7th Ave, NYC.  
Teeger ASCAP 165 E 32 St, NYC.  
WRITERS: A. Mortimer-B. Martin  
ARR: Lee Holdridge FLIP: Goin' South

**#72\***  
**TELL IT ALL BROTHER (3:22)**  
**Kenny Rogers & First Edition-Reprise 0923**  
4000 Warner Blvd. Burbank, Calif.  
PROD: Jimmy Bowen-K. Rogers c/o Amos  
6565 Sunset Blvd. L.A. Calif.  
PUB: Sunbeam BMI 22 W 48 St, NYC.  
WRITER: Alex Harvey  
FLIP: Just Remember You Are My Sunshine

**#73**  
**WHEN WE GET MARRIED (3:05)**  
**Intruders-Gamble 4004**  
1650 Bway, NYC.  
PROD: Gamble Huff 250 S Broad St. Phila, Pa.  
PUB: Elsher BMI c/o Jerry Ross 1855 Bway, NYC.  
WRITERS: D. Hogan-A. K. Music ARR: Bobby Martin  
FLIP: Doctor Doctor

**#74**  
**THAT SAME OLD FEELING (2:53)**  
**The Fortunes-World Pacific 77937**  
6920 Sunset Blvd. L.A. Calif.  
PROD: Noel Walker-Billy Davis c/o World Pacific  
PUB: January BMI 25 W 56 St, NYC.  
WRITERS: Tony MacCauley-John Macleod  
ARR: Gary Sherman FLIP: Lifetime Of Love

**#75\***  
**NO ARMS CAN EVER HOLD YOU (2:31)**  
**Bobby Vinton-Epic 10629**  
51 W 52 St, NYC.  
PROD: Billy Sherrill c/o Epic  
PUB: Gil BMI 1650 Bway, NYC.  
WRITERS: A. Crafer-J. Nebb  
FLIP: I've Got That Lovin' Feelin' (Back Again)

**#76**  
**PRIMROSE LANE (2:28)**  
**O. C. Smith-Columbia 45160**  
51 West 52 Street, NYC.  
PROD: Jerry Fuller c/o Columbia  
PUB: Gladys ASCAP 1619 Bway, NYC.  
WRITERS: W. Shanklin-G. Callendar  
FLIP: Melodee

**#77\***  
**APARTMENT 21 (3:20)**  
**Bobbie Gentry-Capitol 2849**  
1750 N Vine, L.A. Calif.  
PROD: Rich Hall c/o Capitol  
PUB: Wits End BMI  
WRITER: John Wilkins  
FLIP: Seasons Come Seasons Go

**#78**  
**DESTINY (2:28)**  
**Jose Feliciano-RCA 0358**  
1133 Ave Of The Americas, NYC.  
PROD: Rick Garrard c/o RCA  
PUB: Johi BMI 15541 Beach Blvd. Westminster, Cal.  
WRITER: Feliciano ARR: Perry Botkin Jr.  
FLIP: Susie Q

**#79\***  
**EVERYTHING A MAN COULD EVER NEED (2:31)**  
**Glen Campbell-Capitol 1260**  
1750 N Vine, L.A. Calif.  
PROD: Al DeLory c/o Capitol  
PUB: Insign BMI 1619 Bway, NYC.  
WRITER: Mac Davis ARR: Al DeLory  
FLIP: Norwood

**#80\***  
**SUMMERTIME BLUES (3:22)**  
**The Who-Decca 32708**  
445 Park Ave, NYC.  
PROD: Kit Lambert-Chris Stamp, London, Eng.  
PUB: Rumbalero BMI 241 W 72 St, NYC.  
Elvis Presley BMI 241 W 72 St, NYC.  
Viva BMI 6922 H'wood Blvd. H'wood, Calif.  
WRITERS: Eddie Cochran-Jerry Capehart  
FLIP: Heaven And Hell

**#81**  
**SLY SLICK & THE WICKED (2:57)**  
**The Lost Generation-Brunswick 55436**  
445 Park Ave, NYC.  
PROD: Eugene Record c/o Brunswick  
PUB: Julio-Bryan BMI  
WRITERS: Lowrell Simon-Larry Brown Lee  
Gus Redwood ARR: Tom Tom Washington  
FLIP: You're So Young But You're So True

**#82**  
**HUMPHREY THE CAMEL (3:04)**  
**John Blanchard-Misty Morgan-Wayside 013**  
c/o Mercury 35 E Wacker Dr. Chicago, Ill.  
PROD: Little Richie Johnson Belen N. Mex.  
PUB: Back Bay BMI 10 E 44 St, NYC.  
WRITER: J. Blanchard FLIP: A Place In My Mind

**#83\***  
**60 MINUTE MAN (3:30)**  
**Rufus Thomas-Stax 0071**  
926 E McLemore, Memphis, Tenn.  
PROD: Al Bell-Tom Nixon c/o Stax  
PUB: Lois BMI 1540 Brewster, Cinn. Ohio  
WRITERS: Ward-Marks FLIP: The Preacher & The Bear

**#84**  
**I WANT TO TAKE YOU HIGHER (2:51)**  
**Ike & Tina Turner-Liberty 56177**  
6920 Sunset Blvd. L.A. Calif.  
PUB: Daly City BMI 6922 H'wood Blvd. L.A. Calif.  
WRITER: Sylvester Stewart ARR: I. Turner  
FLIP: Contact High

**#85**  
**GOOD MORNING FREEDOM (2:36)**  
**Daybreak-Uni 55234**  
8255 Sunset Blvd. L.A. Calif.  
PROD: Lewis Merenstein for Inherit 57 W 56 St, NYC.  
PUB: Maribus BMI 1780 Bway, NYC.  
WRITERS: R. Cook-R. Greenaway-A. Hammond-  
M. Hazlewood ARR: Geo Butcher  
FLIP: I Could Have Heard The Crying

**#86**  
**GIMME SHELTER (3:00)**  
**Merry Clayton-Ode 70-66003**  
1416 N La Brea, L.A. Calif.  
PUB: Gideon BMI 1700 Bway, NYC.  
WRITERS: Jagger-Richards ARR: Gene Page  
FLIP: Good Girl

**#87\***  
**YOUR OWN BACK YARD (3:50)**  
**Dion-Warner Bros. 7401**  
4000 Warner Blvd. Burbank, Calif.  
PROD: Phil Gernhardt c/o Warner Bros.  
PUB: Wedge/Fat Zach BMI 162 W 56 St, NYC.  
WRITERS: Dion-D. Mucci-Tony Fasce  
FLIP: Sit Down Old Friend

**#88**  
**COTTAGE CHEESE (2:43)**  
**Crow-Amaret 119**  
1717 N Highland, Hollywood, Calif.  
PROD: Bob Monaco for Dunwich  
25 E Chestnut, Chicago, Ill.  
PUB: Yuggoth/Forty Tunes BMI c/o Dunwich  
WRITERS: R. Wiegand-D. Waggoner-D. Craswell  
FLIP: Slow Down

**#89\***  
**YELLOW RIVER (2:40)**  
**Christie-Epic 10626**  
51 W 52 St, NYC.  
PROD: Mike Smith c/o Epic  
PUB: Noma BMI 241 W 72 St, NYC.  
WRITER: J. Christie  
FLIP: Down The Mississippi Line

**#90**  
**CINNAMON GIRL (2:45)**  
**Neil Young-Reprise 0911**  
4000 Warner Blvd. Burbank, Calif.  
PROD: David Briggs-Neil Young c/o Warner Bros.  
PUB: Cotillion BMI 1841 Bway, NYC.  
Broken Arrow BMI 449 S. Bev. Dr. Bev. Hills, Calif.  
WRITER: Neil Young FLIP: Sugar Mountain

**#91**  
**HELLO DARLIN' (2:25)**  
**Conway Twitty-Decca 32661**  
445 Park Ave, NYC.  
PROD: Owen Bradley c/o Decca, Nashville, Tenn.  
PUB: Twitty Bird BMI 913 17th Ave S. Nashville, Tenn.  
WRITER: C. Twitty FLIP: Girl At The Bar

**#92**  
**LET THE MUSIC TAKE YOUR MIND (2:50)**  
**Kool & The Gang-De-Lite 529**  
300 W 55 St, NYC.  
PROD: Gene Redd c/o De-Lite  
PUB: Stephenye/Delightful BMI (same address)  
WRITERS: Kool & Gang-G. Redd  
FLIP: Chocolate Buttermilk

**#93**  
**YOU'VE BEEN MY INSPIRATION (2:55)**  
**Main Ingredient-RCA 0340**  
1133 Ave Of The Americas, NYC.  
PROD: Sylvester Simmons McPherson c/o RCA  
PUB: Mulumood BMI 1790 Bway, NYC.  
WRITER: S. S. McPherson ARR: Bert DeCoteaux  
FLIP: Life Won't Be The Same Without You

**#94\***  
**BIG YELLOW TAXI (2:10)**  
**Neighborhood-Big Tree 102**  
1650 Bway, NYC.  
PROD: Jimmy Bryant c/o Big Tree  
PUB: Sequombi BMI 55 Liberty St, NYC.  
WRITER: J. Mitchell  
FLIP: You Could Be Born Again

**#95\***  
**STEALING IN THE NAME OF THE LORD (3:35)**  
**Paul Kelly-Happy Tiger 541**  
1801 Ave Of The Stars, L.A. Calif.  
PROD: Buddy Killen c/o Tree  
PUB: Tree BMI 905 16th Ave S. Nashville, Tenn.  
WRITER: Paul Kelly FLIP: The Day After Forever

**#96**  
**MELANIE MAKES ME SMILE (3:04)**  
**Tony Burrows-Bell 884**  
1776 Bway, NYC.  
PROD: Tony Macaulay for Mustard  
15 Berkeley St. London W1 England.  
PUB: January BMI 25 W 56 St, NYC.  
WRITERS: Barry Mason-Tony Macaulay  
ARR: Lew Warburton  
FLIP: I'll Get Along Somehow Girl

**#97\***  
**AFTER THE FEELING IS GONE (2:52)**  
**Lulu-Atco 6761**  
1841 Bway, NYC.  
PROD: Jerry Wexler-Tom Dowd-Arif Mardin c/o Atco  
PUB: Cotillion BMI c/o Atco  
Muscle Shoals Sound BMI 3614 Jackson H'way,  
Sheffield, Ala.  
WRITERS: Terry Woodford-George Soule  
FLIP: Good Day Sunshine

**#98**  
**THIS BITTER EARTH (2:25)**  
**Satisfaction-Lionel 3201**  
1345 Ave of the Americas, NYC.  
PROD: Art Wayne-Howard Burgess c/o Lionel  
PUB: Eden BMI 1697 Bway, NYC.  
WRITER: Otis FLIP: Ol' Man River

**#99**  
**DRIVIN' HOME (2:08)**  
**Jerry Smith-Decca 32679**  
445 Park Ave, NYC.  
PUB: Papa Joe's ASCAP 1007 17th Ave S.  
Nashville, Tenn.  
WRITER: Jerry Smith FLIP: Louisiana Blues

**#100**  
**GROOVY SITUATION (3:14)**  
**Gene Chandler-Mercury 73083**  
35 E Wacker Drive, Chicago, Ill.  
PROD: Gene Chandler c/o Mercury  
PUB: Cachand BMI Patcheal BMI c/o Gene Chandler  
1321 S Michigan Ave, Chicago, Ill.  
WRITERS: Russell Lewis-Herman Davis  
ARR: Tom Washington FLIP: Not The Marrying Kind



COMING  
SOON



© EPIC® Marca Reg. T.M. PRINTED IN U.S.A.





# C & W Singles Reviews

## Picks of the Week

**DAVE DUDLEY** (Mercury 73089)

**This Night (Ain't Fit For Nothing But Drinking)** (2:44) (Newkeys, BMI—Hall)  
Dave Dudley follows up his monster, "The Pool Shark" with a Tom T. Hall song that should do very well. Look for "This Night (Ain't Fit For Nothing But Drinking)" on the charts. No flip information available.

**MEL TILLIS AND THE STATESIDERS** (MGM 14148)

**Heaven Everyday** (2:33) (Jack & Bill, ASCAP—Foster, Rice)  
Mell Tillis bows on MGM with a tender ballad which his fans should want to hear. He had one of his biggest records with his last single, "Heart Over Mind," so he's very hot now, and "Heaven Everyday" should be watched closely. Flip: "How You Drink The Wine" (2:42) (Sawgrass, BMI—McCown)

**GUY DRAKE** (Royal American 15)

**Born To Be An Opry Star** (3:08) (Bullfighter, BMI—Drake)  
Guy Drake came into his own with "Welfare Cadillac," and he bids fair to continue his success with "Born To Be An Opry Star," a tale of a would-be C&W luminary. Flip: "Politickin' Pete" (2:40) (Bullfighter, BMI—Drake, Laceyfield)

**COMPTON BROTHERS** (Dot 17352)

**That Ain't No Stuff** (2:09) (BlueCrest, BMI—Frazier)  
Here's a real rousing side from the Compton Brothers that should have no difficulty chalking up plenty of spins and sales for them. "That Ain't No Stuff" sounds like a sure hit. Fine follow-up to "Charlie Brown." Flip: "I Wanna Sing A Country Song" (2:22) (Brothers Two, ASCAP—Compton)

**ANTHONY ARMSTRONG JONES** (Chart 5083)

**In The Flowers** (4:07) (Sue-Mirl, ASCAP—Hinson, Deckard)  
Anthony Armstrong Jones could very well have his biggest record to date in "Sugar In The Flowers." The side is memorable, both in music and lyrics, and will tug the heartstrings of numerous country listeners. Flip: "If You Gotta Go, Go Now" (2:36) (Warner Bros., ASCAP—Dylan)

**DICK CURLESS** (Capitol 5057)

**Hard, Hard Traveling Man** (2:32) (Acuff—Rose, BMI—Bond)  
Dick Curless follows his recent charter, "Big Wheel Cannonball" with another trucking song that may do even better for him. Keep very close tabs on "Hard, Hard Traveling Man." Flip: "Winter's Comin' On Again" (3:07) (Central Songs, BMI—Merritt)

**ROY ACUFF, JR. & SUE THOMPSON** (Hickory 1573)

**Why You Been Gone So Long** (2:42) (Acuff—Rose, BMI—Newbury)  
May well be a chart spot in the cards for Roy Acuff, Jr. and Sue Thompson with "Why You Been Gone So Long." Side is a real good foot-stomper. Flip: "Don't Let The Stars Get In Your Eyes" (2:12) (Four Star, BMI—Willet)

**RAY FRUSHAY** (Paramount 0030)

**Santa Ana Winds** (2:45) (Carlman, BMI—Christopher, Maduri)  
"Santa Ana Winds" is one of those songs that sounds like a ready-made hit, and it could well turn out to be just that. Ray Frushay may wake up and find himself famous. No flip information available.

## Newcomer Picks

**LES SEEVERS** (Chestnut 221)

**There Goes My Life** (2:26) (Don White, ASCAP—Chianco)  
**Two Wrongs** (2:25) (Don White, ASCAP—Chianco)  
This is the strongest newcomer record to appear in a long while. Both sides are excellent, with "There Goes My Life," an emotion-filled ballad, getting the edge. Don't miss out on this one.

## Best Bets

**BARBARA FAIRCHILD** (Columbia 45173)

**Find Out What's Happenin'** (2:52) (Champion, BMI-Crutchfield)  
Could be nice things in store for Barbara Fairchild with this outing. Eye it. Flip: "When You Close Your Eyes I'll Make You See" (3:14) (Champion, BMI-Crutchfield)

**BOBBY WRIGHT** (Decca 32705)

**Hurry Home To Me** (2:36) (Forrest Hills, BMI-Crutchfield, Keith) Bobby Wright could go places with this one. Try it out. No flip information available.

**KIMBERLEYS** (Happy Tiger 547)

**The Family** (2:50) (Kimichi River, BMI-Gay) Cheerful message ode may gain airplay. Give it a spin. Flip: "Leavin' California" (2:43) (Kimichi River, BMI-Gay)

**RAY SANDERS** (United Artists 50689)

**Blame It On Rosey** (2:05) (Wilderness, BMI-Hervey) Ray Sanders could garner coin with "Blame It On Rosey." Merits a listen. Flip: "Waikiki Sand" (1:50) (Unart, BMI-Turner)

**JERRY FOSTER** (Metromedia 184)

**When My Blue Moon Turns To Gold Again** (2:11) (Peer International, BMI-Walker, Sullivan) May be action on tap for Jerry Foster with this one. Scan it. Flip: "I Forgot To Remember To Forget" (2:53) (Hi Lo, BMI-Kesler, Feathers)

**JOHNNY O'KEEFE** (Wasp 124)

**So Why** (1:50) (Blue Spruce, BMI-O'Keefe) "So Why" could do something for Johnny O'Keefe. Watch it. Flip: "My Lonely Lonely World" (2:05) (Blue Spruce, BMI-O'Keefe)

**JERRY MC CAIN** (Royal American 14)

**The Cockfight** (3:55) (Ly-Rann, BMI-Blalock, Kelton) Novelty single could make noise for Jerry McCain. Give it a chance. Flip: "I'm In Trouble" (3:39) (Smar-T, BMI-McCain)

**DUGG COLLINS** (Certron 10005)

**Talk About Me** (2:56) (Mayhew, BMI-Keith) Dugg Collins could gain attention with "Talk About Me." Deserves a spin. Flip: "That's The Way It Is On Monday" (3:15) (Aldrich, BMI-Darnell)



# Top Country Albums

- |    |                                                                                       |    |    |                                                                                     |    |
|----|---------------------------------------------------------------------------------------|----|----|-------------------------------------------------------------------------------------|----|
| 1  | <b>THE BEST OF JERRY LEE LEWIS</b><br>(Smash SRS 67131)                               | 1  | 16 | <b>THE BEST OF EDDY ARNOLD VOL. II</b><br>(RCA LSP 4320)                            | 16 |
| 2  | <b>BABY, BABY</b><br>David Houston (Epic BN 26539)                                    | 3  | 17 | <b>YOU AIN'T HEARD NOTHIN' YET</b><br>Danny Davis & Nashville Brass (RCA LSP 4334)  | 19 |
| 3  | <b>TAMMY'S TOUCH</b><br>Tammy Wynette (Epic BN 26549)                                 | 5  | 18 | <b>THE WORLD OF TAMMY WYNETTE</b><br>(Epic EGP 503)                                 | 25 |
| 4  | <b>JUST PLAIN CHARLEY</b><br>Charley Pride (RCA LSP 4290)                             | 2  | 19 | <b>BIRDS OF A FEATHER</b><br>Jack Blanchard & Misty Morgan (Wayside WSS-33-001)     | 20 |
| 5  | <b>PORTER WAYNE AND DOLLY REBECCA</b><br>Porter Wagoner & Dolly Parton (RCA LSP 4305) | 4  | 20 | <b>STAY THERE TILL I GET THERE</b><br>Lynn Anderson (Columbia CS 1025)              | 18 |
| 6  | <b>IT'S JUST A MATTER OF TIME</b><br>Sonny James (Capitol ST 432)                     | 6  | 21 | <b>LORD IS THAT ME</b><br>Jack Green (Decca DL 75188)                               | 22 |
| 7  | <b>WE'RE GONNA GET TOGETHER</b><br>Buck Owens & Susan Raye (Capitol ST 448)           | 7  | 22 | <b>LONG LONESOME HIGHWAY</b><br>Michael Parks (MGM SE 4662)                         | 17 |
| 8  | <b>MY WOMAN, MY WOMAN, MY WIFE</b><br>Marty Robbins (Columbia CS 9978)                | 11 | 23 | <b>THE STARS OF HEE-HAW</b><br>Various Artists (Capitol ST 437)                     | 24 |
| 9  | <b>IF IT'S ALL THE SAME TO YOU</b><br>Bill Anderson & Jan Howard (Decca 75184)        | 9  | 24 | <b>THE BEST OF PORTER WAGONER VOL. II</b><br>(RCA LSP 4321)                         | 27 |
| 10 | <b>THE WORLD OF JOHNNY CASH</b><br>(Columbia GP 29)                                   | 15 | 25 | <b>LORETTA LYNN WRITES 'EM AND SINGS 'EM</b><br>(Decca DL 75198)                    | —  |
| 11 | <b>YOUR MOTHER'S PRAYER</b><br>Buck Owens & His Buckaroos (Capitol ST 439)            | 12 | 26 | <b>SHE'LL BE HANGIN' ROUND SOMEWHERE</b><br>Mel Tillis & Statesiders (Kapp KS 3630) | 28 |
| 12 | <b>HANK WILLIAMS, JR. GREATEST HITS</b><br>(MGM SE 4656)                              | 8  | 27 | <b>LOVE IS A SOMETIMES THING</b><br>Bill Anderson (Decca DL 75206)                  | 29 |
| 13 | <b>A TASTE OF COUNTRY</b><br>Jerry Lee Lewis (Sun 114)                                | 13 | 28 | <b>HELLO DARLIN'</b><br>Conway Twitty (Decca DL 75209)                              | —  |
| 14 | <b>YOU WOULDN'T KNOW LOVE</b><br>Ray Price (Columbia CS 7918)                         | 14 | 29 | <b>THE CARL SMITH ANNIVERSARY ALBUM</b><br>(Columbia GP 31)                         | 30 |
| 15 | <b>OKIE FROM MUSKOGEE</b><br>Merle Haggard (Capitol ST 384)                           | 10 | 30 | <b>THE LEGEND</b><br>Johnny Cash (Sun 2-118)                                        | —  |

## Best Bets

**TOMMY PHARR** (Certron 10007)  
**Apt. #9** (2:12) (Mayhew, BMI — Paycheck, Austin) Nice version of this while-back Tammy Wynette hit could do something for Tommy Pharr. Deserves a spin. Flip: "Touch My Heart" (2:32) (Mayhew, BMI — Paycheck, Mayhew)

**JACK FORD** (Music of America 1021)  
**I'm Going Back To Nashville** (2:07) (Window, Reba, BMI — Evans) Could be airplay in store for this session. Eye it. Flip: "The Dark Side Of The Moon" (2:03) (Reba, BMI — Evans)

**CLAY ALLEN** (Longhorn 587)  
**The Way You Are** (2:34) (Saran, BMI — Allen) Lend an ear to Clay Allen's performance on this love side. Could get play. Flip: "Promise Her Anything (But Give Her Money)" (2:30) (Akard, SESAC — Allen)

**COLE SHELTON** (Wasp 125)  
**Little Tina Marie** (3:27) (Peer Southern, BMI-Shelton) This one could experience sales for Cole Shelton. Listen to it. Flip: "I'm A Son-Of-A-Gun" (Peer Southern, BMI-Shelton)

**WYNN NELSON** (Musical Spinn 001)  
**Diaper Avenue** (2:25) (Acuff-Rose, BMI-Jay, Brown) Wynn Nelson could have a good future with his Musical Spinn debut. Try it for size. Flip: "Last Goodbye" (2:03) (Acuff-Rose, BMI-Nelson)

**JEFF YOUNG** (Wasp 127)  
**Moving On My Mind** (1:21) (Peer-Southern, BMI-Young) Pleasant toe-tapper could gain attention. Listen to it. Flip: "I Wanna Be Free" (2:25) (Peer-Southern, BMI-Young)

**SYLVIA MARIE** (North Way 211)  
**My First Love** (2:17) (Silverlake, BMI-Bailey) Strong vocal by Sylvia Marie on this one. Could do well. Flip: "Run In The Sun" (Silverlake, BMI-Williamson)

**BILL EUSTIS** (Paramount 0032)  
**Let It Be Known** (2:33) (Racie, BMI-Burnette) Bill Eustis could be heard on the country airwaves with "Let It Be Known." Keep tabs. Flip: "Coleen" (Ensign, Aguila, BMI-Gillis, Richardson, Ward)

**HANK PENNY** (Wasp 126)  
**The Strong Black Man** (3:03) (Penny-Penny) Narrative outing reminiscent of "Big John." Could catch some attention. Flip: "Little Red Wagon" (1:23) (Penny-Griffin)

**FRANKIE VEE** (Tonka 24)  
**Spanish Two Step** (1:58) (Tata Grande, BMI-Brewer) Pleasant instrumental could do nicely on the airwaves. Warrants a listen. Flip: "Somewhere There's Someone" (2:30) (Tata Grande, BMI-Hall, Copeland)

# CONWAY TWITTY'S HELLO DARLIN

There's no question that Conway Twitty's "Hello Darlin'" 32661 is a number one country hit. There's also no question that "Hello Darlin'" has made the big move and crossed country into pop. (And from hit single into hit LP!)  
Decca Records, Land of the Country Giants.  
Twitty Bird Music Publishing Co., Nashville, Tenn.





# Country Roundup

Loretta Lynn says, "It's real hard to climb that ladder to the top. Don't step on anybody as you go up 'cause you have to step on the same people on the way down and you come down much faster" . . . Orlando's WHOO is going to the birds for "Tennessee Bird Talk." The listener who can name the most birds correctly in the Sheb Wooley parody wins a pair of baby Mynah birds. Fifty runners-up receive a copy of the single . . . "The Sounds of Good-bye," written by Eddie Rabbitt and Dick Heard, is being used in a feature length film presently in production in India. The film, entitled "Bombay Talkie," will be shown around the world in theaters and on television . . . Columbia's David Rogers, currently appearing at the Golden Nuggett in Las Vegas through July 1, is scheduled to tape Porter Wagoner's widely syndicated TV'er July 27. Roger's recent single is "So Much In Love With You" . . . The latest in a series of successful shows promoted by PLS Productions of Snow Hill, North Carolina, was a package including Tompall and the Glasser Brothers, David Houston and Billie Jo Spears at Goldsboro last weekend. A benefit for the Wayne County Law Enforcement Association, the show was sold out a week in advance . . . Faron Young to work four shows in Honolulu, Hawaii, on July 10th and 11th . . . George Morgan's new one is "Kansas City Stock Yard" on Stop Records . . .

George Hamilton IV back home after his fifth European trip the past year. The IV's recent single on RCA is "She's A Little Bit Country" . . . Webb Pierce Enterprises will headquarter in new offices in Music City in mid-July. The suite of offices formerly occupied by Buck Owens Enterprises at 1819 Broadway in Music City will house Wandering Acres Music, Tuesday Music and Fa-Web Music. Pierce, a veteran of twenty years with Decca, has increased his road show activity following his recent signing with the Buddy Lee Agency . . . Jack Reno is currently recovering from surgery, which has kept him out of action since the first of June. Reno's new Dot release is "Mrs. Miller" . . . To toast Hank Locklin's new Nashville Room Club in Pensacola, Hank Williams, Jr. will cater a barbeque and picnic on the ground in Pensacola from his Music City kitchen Mel Tillis will be on hand . . . Loretta Lynn brought her entire show, featuring Peggy Sue, Sonny Wright, and the Nashville Tennesseans, to Peru, Indiana for an afternoon and evening performance June 21 for her step-father, Tommy Butcher. Butcher regularly books shows at the 4-H Building outside Peru, and he had not even thought about Father's Day when he booked Loretta for Sunday. However, he admitted that the two full houses made a fine Father's Day gift . . . The Florida Boys are slated to appear in cameo roles in the historical drama, "Shepherd of the Hills," the week of July 13-18. The drama is presented Monday through Saturday from Memorial day through late Fall each year at the old Mill Theatre at the Shepherd of the Hills Farm in Branson, Missouri . . .

Ray Price to appear at the Astrodome in Houston, Texas on Saturday, July 11th. Ray will appear between ball games with the Houston Astros and the San Francisco Giants . . . Escoheag, Rhode Island will host a country music festival in July, according to Stepping Stone Stables' general manager, Rod Harris . . . MGM national sales and promo man B. J. McElwee on a real "high" from action of new artists Billy Walker and Mel Tillis . . . Bob Woods has the first country LP on Ranwood, "Introducing Bob Woods," produced by Don Law . . . Tom Hartman, newly elected GM of Hollywood Tree, scheduled for a brief return to Nashville in July, while producing Ronnie Sessions on Republic Records . . . The Judy Lynn Show has rented a streamlined Greyhound bus and driver for a 14-day tour of the East, New York, Pennsylvania, Indiana, starting July 6, with accent on

"Vacation, Pleasure, Fun" as the band members will be accompanied by their wives . . . Red Lane of Tree International/RCA Records fame, checks in as co-writer on "The Johnny Cash Show" for next season. Reba Hancock reports from the House of Cash, "Red's one of the new breed of writers which everyone can identify with, and we're glad to have him" . . . The Calhoun Twins, the country jet set from St. Martin, V. I., in Music City conferring with Stop Record chief Pete Drake on material and recording . . .

Piano Red, now appearing at the Underground in Atlanta, has a new album on Starday-King titled "Dr. Feel-good—Underground Atlanta" . . . Loretta Lynn recently turned away fans at first show in Valdosta, then played second 10 PM show to a packed house . . . Mayf Nutter (Starday-King), nominated by C&W Academy for most promising male vocalist, has just completed a starring role in a "Bonanza" show, "The Weary Willies" . . . Dick Heard, president of Royal American Records has announced the appointment of Rudy Hickman to the post of national promotion director. Hickman was formerly with Newkeys Music . . . Plantation artist Harlow Wilcox has been set for personal appearances that will carry him through to mid-July, according to Don Fowler of CTA Booking in Nashville. The latest Harlow Wilcox single on Plantation is "Cripple Cricket" . . . Decca's Bobby Wright to co-host an "Up-Beat" Show in Cleveland during June. Bobby's latest release is "Hurry Home To Me" . . . The Tokyo Happycoats arrived with 40 pieces of luggage to record a new album and singles for Starday-King under direction of Darol Glenn . . . Kapp artist Leroy VanDyke and the Auctioneers play a series of fair dates July 19 through September 7 throughout the Midwest area, New York, Ohio, Indiana and Pennsylvania . . . Roy Drusky and the Loners to tour Missouri and Oklahoma, winding up with a return four-day stint in Florida the last of June . . . Charlie Walker appearing June 25, 26 and 27 at the rodeo in Georgetown, Texas.

## Wheeler, Throckmorton Signed To Hilltop

NASHVILLE — Karen Wheeler and Sonny Throckmorton have been signed to Hilltop Records, a division of Pickwick International, it was announced last week by Ralph Davis, head of Pickwick International's Nashville publishing operation.

The first session on these two artists has been concluded and the records will be released immediately.

### "Record Ourselves"

In announcing the signing, Davis noted that "Too often, first-rate materials which we publish go unnoticed and unrecorded. It is our decision to call attention to and exploit these promising copyrights by recording them ourselves. In that way, we will be able to best serve our writers by doing just that."

## Ireland's Entertainment To Be Supplied By Long Agency

NASHVILLE — Entertainment for the recently formed chain of Ireland's Restaurants will be co-ordinated by the Hubert Long Agency and Ireland's Bill Kleinart and Ben Stuart.

The Ireland's chain now includes restaurants in Lexington, Memphis, Athens, Ga., Tuscaloosa, Ala., with Nashville serving as home-base.

Ireland's "steak and biscuits", so popular in the Nashville area, are now the headlining standard item in all their establishments.



# Country Top 60

- 1 **HE LOVES ME ALL THE WAY** (Algee — BMI) 1  
Tammy Wynette (Epic 10612)
- 2 **SHE'S A LITTLE BIT COUNTRY** (Wilderness — BMI) 3  
George Hamilton IV (RCA 9829)
- 3 **LONG LONG TEXAS ROAD** 5  
Roy Drusky (Mercury 73056)
- 4 **I NEVER ONCE STOPPED LOVING YOU** (Stallion — BMI) 4  
Connie Smith (RCA 9832)
- 5 **HELLO DARLIN'** (Twitty Bird — BMI) 2  
Conway Twitty (Decca 32661)
- 6 **IF I EVER FELL IN LOVE (WITH A HONKY TONK GIRL)** (Newkeys — BMI) 8  
Faron Young (Mercury 73065)
- 7 **HEART OVER MIND** (Cedarwood — BMI) 7  
Mel Tillis (Kapp 2086)
- 8 **WONDER COULD I LIVE THERE ANYMORE** (Hall-Clement — BMI) 9  
Charley Pride (RCA 9855)
- 9 **JESUS, TAKE A HOLD** (Blue Book — BMI) 10  
Merle Haggard (2838)
- 10 **KANSAS CITY SONG** (Blue Book — BMI) 15  
Buck Owens & The Buckaroos (Capitol 2783)
- 11 **I WISH I HAD A MOMMY LIKE YOU** (Algee — BMI) 13  
Patti Page (Columbia 45159)
- 12 **I CAN'T SEEM TO SAY GOODBYE** (Don Robertson — ASCAP) 6  
Jerry Lee Lewis (Sun 1115)
- 13 **SOMEDAY WE'LL BE TOGETHER** (Jobete — BMI) 24  
Bill Anderson & Jan Howard (Decca 32689)
- 14 **WARMTH OF THE WINE** (Window — BMI) 17  
Johnny Bush (Stop 5402)
- 15 **HEAVENLY SUNSHINE** (Al Gallico — BMI) 11  
Ferlin Husky (Capitol 2793)
- 16 **I DO MY SWINGING AT HOME** (Algee — BMI) 12  
David Houston (Epic 10596)
- 17 **LOVIN' MAN** (Arlene Harden (Columbia 45120) 14
- 18 **HELLO MARY LOU** (January, Champion — BMI) 23  
Bobby Lewis (United Artists 50668)
- 19 **YOU WANNA GIVE ME A LIFT** (Sure-Fire — BMI) 26  
Loretta Lynn (Decca 32693)
- 20 **I NEVER PICKED COTTON** (Central Songs/Freeway — BMI) 27  
Roy Clark (Dot 17349)
- 21 **PLAYIN' AROUND WITH LOVE** (Algee — BMI) 20  
Barbara Mandrell (Columbia 45143)
- 22 **YOU AND ME AGAINST THE WORLD** (Contention — SESAC) 19  
Bobby Lord (Decca 32657)
- 23 **LAND MARK TAVERN** (Passkey — BMI) 36  
Del Reeves & Penny DeHaven (United Artists 50669)
- 24 **TOGETHERNESS** (Blue Book — BMI) 16  
Buck Owens & Susan Raye (Capitol 2791)
- 25 **TELL ME MY LYING EYES ARE WRONG** (Blue Crest — BMI) 32  
George Jones & Jones Boys (Musicor 1408)
- 26 **ROCKY TOP** (House of Bryant — BMI) 30  
Lynn Anderson (Chart 5068)
- 27 **I'LL BE YOUR BABY TONIGHT** (Dwarf — ASCAP) 28  
Claude King (Columbia 45142)
- 28 **A GOOD THING** (Padskey — BMI) 29  
Bill Wilbourn & Kathy Morrison (United Artists 50660)
- 29 **HUMPHREY THE CAMEL** (Back Bay — BMI) 40  
Jack Blanchard & Misty Morgan (Wayside 013)
- 30 **I'M LEAVING IT UP TO YOU** (Venice — ASCAP) 18  
Johnny & Jonie Mosby (Capitol 2796)
- 31 **DRIVIN' HOME** (Papa Joe's — ASCAP) 33  
Jerry Smith (Decca 32679)
- 32 **WHEN A MAN LOVES A WOMAN** (Forrest Hills — BMI) 41  
Billy Walker (MGM 14134)
- 33 **DON'T KEEP ME HANGIN' ON** (Marson — BMI) 43  
Sonny James (Capitol 2834)
- 34 **THE MOST UNCOMPLICATED GOODBYE I'VE EVER HEARD** (Blue Crest — BMI) 21  
Henson Cargill (Monument 1198)
- 35 **IT DON'T TAKE BUT ONE MISTAKE** (Minstrel — BMI) 22  
Luke The Drifter, Jr. (MGM 14120)
- 36 **FOR THE GOOD TIMES** (Buckhorn — BMI) 47  
Ray Price (Columbia 45178)
- 37 **SON OF A COAL MAN** (United Artists — ASCAP) 39  
Del Reeves (United Artists UA 50667)
- 38 **I'VE JUST BEEN WASTING MY TIME** (John Wesley Ryles (Columbia 45119) 31
- 39 **HIT THE ROAD JACK** (Tangerine — BMI) 35  
Connie Eaton & Dave Peel (Chart 5066)
- 40 **COME AND GET IT MAMA** (Tuff — BMI) 42  
Charlie Louvin (Capitol 2824)
- 41 **LUZIANA RIVER** (Birmingham, Norma, S.P.R. — BMI) 46  
Van Trevor (Royal American 9)
- 42 **GOIN' HOME TO YOUR MOTHER** (Blue Book — BMI) 45  
Hagers (Capitol 2803)
- 43 **A MAN'S KIND OF WOMAN** (Twin Forks, Ragmar — BMI) 48  
Eddy Arnold (RCA 9848)
- 44 **REMOVING THE SHADOW** (Hank Williams, Jr. — BMI) 53  
Hank Williams, Jr. & Lois Johnson (MGM 14136)
- 45 **DUTY NOT DESIRE** (Shelby Singleton — BMI) 55  
Jeannie C. Riley (Plantation 59)
- 46 **THE WONDER OF YOU** (Duchess — BMI) —  
Elvis Presley (Capitol 9835)
- 47 **MARY GOES ROUND** (Jack — BMI) 51  
Bobby Helms (Certron 1002)
- 48 **LET'S GO FISHER BOYS (THE GIRLS ARE BITIN')** (Green Grass — BMI) 52  
Charlie Walker (Epic 10610)
- 49 **A PERFECT MOUNTAIN** (Acuff-Rose — BMI) —  
Don Gibson (Hickory 1571)
- 50 **LEAVIN' ON A JET PLANE** (Cherry Lane — ASCAP) 54  
The Kendalls (Stop 373)
- 51 **MULE SKINNER BLUES** (Peer Int'l — BMI) 61  
Dolly Parton (RCA 9863)
- 52 **DO IT TO SOMEONE YOU LOVE** (Newkeys — BMI) 57  
Norro Wilson (Mercury 73077)
- 53 **SALUTE TO A SWITCHBLADE** (Newkeys — BMI) 63  
Tom T. Hall (Mercury 73078)
- 54 **ONE NIGHT STAND** (Blue Book — BMI) 60  
Susan Raye (Capitol 2833)
- 55 **CRIPPLE CRICKET** (Shelby Singleton — BMI) 58  
Harlow Wilcox & The Oakies (Plantation 60)
- 56 **BIG WHEEL CANNONBALL** (Southern — ASCAP) —  
Dick Curless (Capitol 2780)
- 57 **FLYING SOUTH** (Coldwater — BMI) —  
Hank Locklin & Danny Davis & Nashville Brass (RCA 9849)
- 58 **AN OLD LOVE AFFAIR, NOW SHOWING** (Moss Rose — BMI) —  
Leroy Van Dyke (Kapp 2091)
- 59 **SO MUCH IN LOVE WITH YOU** (Acclaim — BMI) 59  
David Rogers (Columbia 45111)
- 60 **PICK ME UP ON YOUR WAY DOWN** (Tree — BMI) —  
Carl Smith (Columbia 45177)
- 61 **OLD MAN WILLIS** (Combine — BMI) —  
Nat Stuckey (RCA 9833)
- 62 **EVERYTHING A MAN COULD EVER NEED** (Insign — BMI) —  
Glen Campbell (Capitol 1260)
- 63 **TOMORROW NEVER COMES** (Norma — BMI) —  
Slim Whitman (Imperial 66441)
- 64 **IF THIS IS LOVE** (Contention — SESAC) —  
Jack Greene (Decca 32699)
- 65 **BROTHER RIVER** (Tree — BMI) —  
Johnny Darrrell (United Artists 50675)



# *cash box*

INTERNATIONAL MUSIC SECTION



Always popular on the continent, Roger Whittaker has been on the fringe of success for several years but really hit the big time in the U.K. with "Durham Town" (Columbia). Now contracted to RCA, Roger followed up his success in England with "I Don't Believe In If Any More" and achieved American recognition via "New World in the Morning."



# CashBox Great Britain

Another sign of the coming times is the formation of W. H. Smith Cassettes Ltd. This new venture by the giant book, newspaper, stationery and disk retailing chain testifies to the growing confidence in hitherto untried media such as the video cassette, which is the primary motive for the new Smith company. The video cassette has also been tagged the television cassette, and Philips is expected to launch it on the market here by the end of 1971. The thinking behind the Smith move is that initially this product will be best handled on a hire-loan basis on account of its cost, and the chain will utilize its experience and know-how gleaned from the lengthy life of its lending library service, discontinued some years ago but easily possible to revive to handle video cassettes once sufficient demand is proved. Smith will probably stock video cassettes in bulk at its multi-million pound supply center at Swindon. The directors of the new company are Smith chairman C. H. W. Troughton, deputy chairman P. W. Bennett, Lord Brabourne, who is a Smith director, and corporate planning chief C. D. Yarrow, who will act as managing director of Smith Cassettes.

A campaign to overcome the traditional summer sales slump with a target of 500,000 sales on six LPs was unveiled at a promotion presentation by Music for Pleasure, the budget album specialists. The LPs concerned are "Summer In Spain," Dean Martin's "Hey Brother, Pour The Wine," Count Basie's "Basie's Beatle Bag," "Viva Tijuana," "More Music From The Greek Island," and "Edith Piaf." A Consumer competition is being organized, open to customers buying one of the six LPs, and the prizes are vacations in Rio de Janeiro, Torremolinos and Paris. Dealers who sell albums to the three prizewinners will receive £100, £50, and £25, respectively. Attending the presentation were MFP's entire sales force and about 40 disk retailers and other trade representatives. A travel movie depicting the three vacation destinations was screened, presented by a British United Airways hostess. BUA is collaborating with MFP in running the competition.

The first four members of Warner-Reprise's embryo sales force hit the road two weeks ago in their super de luxe estate cars. They are Tony Zonenblick, former Philips salesman who will work out of Leeds; Trevor Edwards, who has worked for Pye, Major Minor and Saga and who will cover London; Warren Taylor, who worked for Saga after coming here from the New Zealand Broadcasting Corporation and whose Warner-Reprise sales bailiwick will be Surrey, and Alan Wade, former Polydor Midland and South Wales rep, who will work out of Wolverhampton. Their main initial task is to promote additional sales on W-R product by fixing dealer and artist promotion on a local and national basis. They will be briefed regularly from the W-R headquarters in New Oxford Street, London, by means of pre-recorded cassettes for use in their automobiles. W-R sales manager Ron Smith intimated that the selling quartet would be strengthened with new recruits as and when circumstances indicated.

The smoldering controversy about the abolition of the 5% returns allowance by EMI and its partial abolition by other companies shows signs of flaring up again following an appeal by the Music Trades Association to its members for views on the subject. 582 dealers have responded to date, and unanimously ask for the reinstatement of the 5% allowance. Christopher Foss, honorary secretary of the Gramophone Record Retailers Committee of the MTA, stated that the dealers want at least 5% allowed on all product, including cassettes, and also seek improved trading terms. Following this response and the solidarity of opinion, the MTA is expected to ap-

proach the record companies officially for talks on the matter.

Adrian Rudge has been named promotion manager for Polydor Records, and took up his new duties on July 1st. A former EMI and Page One staffman, Rudge has been working in partnership with Tony Palmer, another EMI alumnus, in a promotion and production enterprise called Finito. It is not likely to be finito for this company, however, as Palmer has busy recording commitments over the next few months, and may appoint a replacement for Rudge to handle the promotion end. Rudge takes over from Phil Greenop at Polydor, and Greenop is now responsible for artist development. Peter Knight, hitherto Polydor A & R co-ordinator, has been named label manager and all three men report to creative division general manager Alan Bates.

Hardie Ratcliffe, general secretary of the Musicians Union since 1948, intends to retire in the spring of next year, and a ballot is being held this month to decide his successor. The 32,000 MU members have three candidates from which to choose, and they are assistant general secretary Harry Francis, executive committee member John Morton, and south-west district organizer Howard Rudge. Whatever the outcome of the ballot, it seems very unlikely that the MU will modify its intransigent attitude on the amount of needle time permitted to the BBC for disk programs each week. Francis particularly is a notable hardliner for maintaining the status quo.

Evolution Records are expanding on the international front with a three-year licensing deal with Disco Grafica Talar S.A. of Barcelona whereby their product will be released throughout Spain with an initial release of six singles. Another international deal concerns Arzachel whose album is to be issued by Deutsche Vogue in Germany, Austria, Switzerland, Scandinavia and the Benelux countries.

Fred Marks, newly appointed managing director of Philips Records has announced two new executive appointments in the expansion of the company's activities. P.R. man Paddy Fleming has been appointed to the newly created position of International Promotion Manager teaming up with both U.K. and European artistes in all media activities with a view to creating top exposure for "middle of the road" artistes on an international basis. Richard Swainson has been appointed U.K. Promotion Manager responsible for the co-ordination of local artistes in the "pop underground" area. Press officer Nick Massey will work closely with both Fleming and Swainson reporting directly to Marks. The new appointments are effective from July 1st.

Musical personalities figures prominently in the Queen's Birthday Honors. Sir David Webster, retiring this month after twenty-five years as Royal Opera House general administrator, becomes a Knight of the Royal Victorian Order (KCVO). CBSs went to mezzo Janet Baker, Hugh Bean, former concertmaster of the BBC Symphony Orchestra, and singing tutor Roy Henderson, whose pupils included the late Kathleen Ferrier. The Amadeus Quartet now parade four OBEs, with violinist Sigmund Nissell, violist Peter Schidlöf and cellist Martin Lovett joining the leader Norbert Brainin, who already held the award. Another OBE went to Welsh composer-conductor Mansell Thomas, and conductor Henry Krips, half brother of Josef Krips, received an MBE, as did Jack Hatchett, joint managing director of British Piano Actions, who got the honor for services to export. Veteran bandleader Henry Hall, one of the first broadcasting stars in the infant years of radio, got a CBE. For those wondering, CBE means Commander of the Order of the British Empire, OBE means Order of the British Empire, and MBE is Mem-



FAMOUS AMERICANS AND BRITONS — In London signing their new publishing contract, seated: Neil Reshen (business manager Famous USA); Leslie Gould (managing director Famous U.K.); Jacques Chabrier (president Chappell) and standing: Frank Coachworth (general manager Chappell) and Bill Gallagher (president of Famous).

## Great Britain's Top Best Sellers

This Week	Last Week	Weeks On Charts	Title
1	2	3	*In The Summertime—Mungo Jerry—Dawn Maxi—Our Music
2	1	6	*Yellow River—Christie—CBS—Gale
3	3	4	Groovin' With Mr. Bloe—Mr. Bloe—DJM—DJM
4	6	4	Cottonfields—Beach Boys—Capitol—Kensington
5	4	5	Honey Come Back—Glen Campbell—Capitol—Jobete/Carlin
6	9	3	Everything Is Beautiful—Ray Stevens—CBS—Peter Maurice
7	5	6	Question—Moody Blues—Threshold—Tyler
8	15	3	*Sally—Gerry Monroe—Chapter One—Keith Prowse
9	7	8	*Back Home—England World Cup Squad—Pye—Mews
10	12	4	Abraham, Martin & John—Marvin Gaye—Tamla Motown—R. Mellin
11	8	4	Up The Ladder To The Roof—Supremes—Tamla Motown—Jobete/Carlin
12	14	3	*The Green Manalishi—Fleetwood Mac—Reprise—Fleetwood
13	—	1	*All Right Now—Free—Island—Blue Mountain
14	10	5	ABC—Jackson 5—Tamla Motown—Jobete/Carlin
15	11	6	*I Don't Believe In It Anymore—Roger Whittaker—Columbia—Croma/Tembo
16	19	2	It's All In The Game—Four Tops—Tamla Motown—Warner Bros.
17	13	12	Spirit In The Sky—Norman Greenbaum—Reprise—Great Honesty
18	—	1	*Goodbye Sam, Hello Samantha—Cliff Richard—Columbia—Intune
19	—	1	*I Will Survive—Arrival—Decca—Essex
20	—	1	Kentucky Rain—Elvis Presley—RCA—Carlin

\*Local Copyrights

## Great Britain's Top Ten LP's

1	Let It Be—Beatles—Apple
2	Bridge Over Troubled Water—Simon & Garfunkel—CBS
3	Live At Leeds—The Who—Track
4	McCartney—Paul McCartney—Apple
5	Deja Vu—Crosby, Stills, Nash & Young—Atlantic
6	Easy Rider—Various Artists—Stateside
7	Andy Williams Greatest Hits—CBS
8	Led Zeppelin 2—Atlantic
9	World Beaters Sing The World Beaters—1970 England Football Squad—Pye
10	In The Wake Of Poseidon—King Crimson—Island

ber of the British Empire.

Quickies: EMI to distribute Billy McBurney's Outlet label throughout Ireland . . . Elvis Presley's "On Stage '70" album recorded at Las Vegas to be released here by RCA July 10th . . . Prophecy Records president Mickey Shapiro here to fix British and European distribution for his label and seek recording and producing talent . . . Tom Ransley named manager of the recording and international services department of CBS . . . Death of Mrs. M. E. Rosetti, aged 82, widow of the co-founder of the well-known instrument firm . . . A & M released "A Song Of Joy" by Miguel Rios by special arrangement with Pye, who first issued the single from the Hispavox

catalogue . . . Neville Smith, disk and tape chief of the Australian Astor company, here on business and to explain to licensors the effect of the commercial broadcasting deadlock in Australia following the implementation of the Copyright Act of 1968 . . . Graham Bond signed to three-year deal by Philips, and his first album will be released on Vertigo in the fall . . . Stevie Wonder in London for "Talk of the Town" engagement commencing June 24th . . . Songwriter Jerry Lordan (writer of many past hits for the Shadows) comes back on the scene as an artiste with his own composition "The Old Man and the Sea" issued on CBS and published by Francis Day & Hunter.



## Warners Opens Australian Co.; Paul Turner Heads Operation

SYDNEY, AUSTRALIA — Australia will become the third foreign country in which Burbank-based Warner Bros. Records Inc. has established its own local and totally self-contained record company, reports Phil Rose, vice president and director of overseas operations.

Warner Bros. Records of Australia, which formally begins operations Oct. 1, will be headed by 33-year-old Paul M. Turner, Australian-born record industry exec.

Rose emphasized that the Australian company, to be headquartered in Sydney, will be an entirely autonomous unit in the growing and lucrative Australian market.

Turner and staff will have complete control of release and promo policy in the country to fit local needs and conditions. Patterned after the United Kingdom operation, formed June 1, 1969, the Australian operation will, according to Rose, be a tight, aggressive promotion-oriented operation. Turner will report directly to Rose.

Warner Bros. Records has severed its arrangement with its Australian licensee by allowing its contract to elapse. Pressing and distribution functions of the new company will be leased out to various Australian firms.

Both Turner and Rose stressed that the new firm would be a "recording" company in every sense of the word. A talent building campaign is already in operation.

"Any Australian artists signed by our new label," Rose emphasized, "will have the added windfall of international exposure and exploitation via our American concern, our companies in Great Britain and Canada, and our network of licensees around the world."

Turner said that he is currently completing the formation of a nationwide promotion staff.

Mo Ostin and Joe Smith, president and executive vice president, respectively, of the parent Warner Bros. Records, stressed that the formation of Warners' own company in Australia was a "natural step" hard on the heels of the "unprecedented success" of its Canadian firm, founded in 1967 and now headed by Kenneth N. Middleton, and its British unit, which is headed by Ian Ralfini.

However, both Ostin and Smith emphasized that the company had no plans "in the immediate future" for the formation of any other company in foreign countries. Except for these three essentially English-speaking countries, Warner Bros. product in all other world markets is released, distributed and promoted by foreign licensees.

### Turner's Background

In selecting 33-year-old Turner as the head of its Australian company, Warner Bros. Records is following its trend in choosing both youthful and

youthful thinking executives. Ralfini was 32 when named to the head of the U.K. company; Middleton had just turned 40 when he was tapped to head the Canadian company.

Turner has been in the record business for approximately half of his life, having joined Phillips Records at 17 in his native Perth. He had the advantage of quickly becoming familiar with Phillips' worldwide catalogues, including—at that time—America's Columbia Records.

At 19, he moved to Melbourne to become the representative for the state of Victoria, of which Melbourne is the metropolis. Two years later, at 21, he became Phillips Records' manager for Victoria.

In 1962, Turner was further promoted and moved to Phillips' head office in Sydney, where he became sales manager for the state of New South Wales, Australia's largest market. In 1967, he became General Manager for a then-new Phillips subsidiary label, Phonogram Recordings Ltd., which had been formed by Phillips in Holland and D.G.G. in West Germany.

## On Content Ruling: Record Men & Publishers Map Assistance To Broadcasters

TORONTO — The Canadian Radio Television Commission (CRTC) has finally approached the important arm of the recording business and asked for assistance in making its proposed 30% (now law) more appetizing for the broadcasters.

With Nimbus 9's Allan Macmillan representing the CRTC (the first time anyone from the record business has been approached by the Commission), a series of meetings was instigated with representatives from the Canadian Record Manufacturers' Association, Canadian Music Publishers' Association, Composers, Authors and Publishers Association, BMI Canada Ltd. and RPM Weekly.

It's hoped that through these meetings a practical method of identification of records meeting the four conditions set out by the CRTC can be arranged for the broadcaster. It's obvious the broadcasters are in a bind and have to look to those people for assistance. The 30% content ruling, as

set down, will require the broadcasters to hire extra hands to research their current library and set up a system they hope won't mislead them. The getting together of the record men and publishers could, on the other hand, solve many of the broadcaster's problems. The meetings already held have moved these important people in the direction of making available to all licensers of broadcast outlets a comprehensive listing of recorded music from existing catalogs qualifying as domestic content according to the regulations. Target date for this listing has been set as Aug. 1, 1970 with completion by Oct. 1.

It has also been agreed upon for the adoption of a uniform system of label identification by title of all new Canadian and foreign produced recordings released in Canada and which qualify as domestic content under: the 30% domestic content of performance, production and composition of music or lyrics, and 5% domestic content for composition of music or lyrics.

It is also hoped to expand the committee to include reps from private and public broadcast outlets.

Elected co-chairmen of this association of record men and music publishers were: Bert Betts, secretary of the Canadian Record Manufacturers' Association and John Bird of the Canadian Music Publishers' Association.

## Radio Luxembourg To Sponsor Second Producers Festival

LONDON — The combined services of Radio-Tele-Luxembourg are again sponsoring a Grand Prix to honor the role played by record producers in the European music business.

Top producers from Austria, Belgium, France, Germany, Great Britain, Ireland, Luxembourg, Netherlands and Switzerland, will compete for the Radio Luxembourg trophy, in the Grand Duchy's National Theatre on Wednesday, October 28.

The rules have been changed this year and producers will not be required to submit their entries in two languages. An English language entry for this country is all that is required. Entries close at 6 p.m. on Sept. 15th, and a British jury will convene that evening to select the three songs to represent this country in the Gala.

The show, featuring the 12 finalists, will be carried as a color TV special on part of the Eurovision link. The 12 productions selected for the final will be promoted extensively throughout Europe on all the services of Radio Luxembourg from October 12. The 1st,

2nd and 3rd winners will receive one play a day each on all services from 1st November for two weeks.

A new feature has been added this year to the Gala evening. After the competition, top stars from each of the five major Radio Luxembourg countries will appear. The artists from Holland are expected to be Shocking Blue, Germany is presenting Peter Alexander and Joe Dolan will appear for Britain and Ireland.

Geoffrey Everitt 208's general manager, said "We are looking to the record business for support in this event. This company is allocating a sum in excess of £25,000 for this promotion and the Gala is a prime European showcase for artists. This year we would like a record company whose entry is selected for the final to guarantee European release of the disk".

"We shall again be chartering a plane to take the British contestants and music press to Luxembourg—the event is growing in importance and we shall do everything to ensure that the 1970 Gala is a great success".

## Bill Martin In U.S.

LONDON — Writer/producer Bill Martin, whose current smash, "Back Home" by the World Cup Squad on Pye is approaching the half-million mark in sales, is now in the U.S. placing masters from his Martin-Coulter Production Co. He's staying at the St. Regis Hotel in New York, and plans to fly to Hollywood after a week's stay.

## BMI Expects To CISAC

NEW YORK — BMI president Edward M. Cramer, board chairman Sydney M. Kaye, and vice president of foreign performing rights administration Leo Cherniavsky are attending the International Confederation of Societies of Authors and Composers (CISAC) in the Canary Islands the last week in June.

## Perrey To Europe

NEW YORK — Composer and Vanguard recording artist Jean Jacques Perrey left for France and will remain in Europe for 10 weeks during which time he will promote his single, "Passport to the Future." Some of the cities he will visit include Brussels, Amsterdam, London, Berlin, Hamburg, Geneva, Rome, Milan, and,

## MCA's Broderick: C&W Artist Tours Increase Sales

NEW YORK — Following the recent MCA country artist tour of England, Norway, Sweden, Holland, Germany and Ireland, Dick Broderick, vice president of MCA Records International, reports a marked increase in sales of country albums throughout the territories where the artists made personal appearances. Big sales are also anticipated for Conway Twitty's single, "Hello Darlin'" in England and Europe following its No. 1 chart position in the U.S. Twitty was featured in the recent MCA country tour. Continuing their promo activity for MCA Record artists overseas, Broderick also announced that Jonathan Swift will participate in the Coupe d'Europe at Knokke, Belgium, July 18. Swift will be a member of the U.S. team and will introduce a new song specially written for him by hit song writers Paul Vance and Lee Pockriss. The Knokke Festival competition will be televised throughout Europe, and this year will mark the first time that an American team has been entered. MCA Records will rush release a Jonathan Swift single featuring the new song to tie in with Swift's appearance.

Also appearing at the festival on the English team will be Tony Christie, a newly signed MCA artist in the United Kingdom.

Broderick also reported world-wide success for Vinnie Bell's "Airport Love Theme." Another MCA single that has been released throughout the Continent and is getting extra heavy promo in Germany features Karen Wyman singing two of the titles she will perform on German television July 1. The show "Show an Bord" will be telecast from the liner Bremen, docked in New York harbor and beamed via satellite to West Germany.

of course, his native city, Paris. Several television appearances have been set up for Perrey. Barclay Records will release the single in the fall in Europe.

## Monument Execs To UK, Continent

HOLLYWOOD — Monument Records president Fred L. Foster and Bobby Weiss, vice-president and director of the firm's international division, arrived in London over the weekend (27) for a series of meetings with Decca, the label's record licensee, and KPM, the music publishing partners of Combine, in England.

In addition, the execs will be conferring with various British recording and production teams on securing product for release on the Monument label in the USA and certain foreign markets, similar to their recent acquisition of certain Penny Farthing disks. While in London, they will hold meetings with Peter Phillips, manager of the overseas division of KPM and Johnny Gordon, professional manager for the Combine/KPM operation.

One of the main topics of their discussions with Decca and KPM, will be to arrange special promo campaigns in behalf of Monument and Combine artists/writers Tony Joe White and Kris Kristofferson.

During their stay, they will maintain headquarters in care of Keith Prowse Music and will arrange all appointments via the office of Peter Phillips.



TURNER & ROSE



# CashBox Belgium

The copyright of Marva's "Tipi tipiti" is published by Sugarmusic Benelux. The number is currently number 12 in the BRT Hitgolf National top 30. Paul Sebastian's "A Chicago" on Hebra Records is now really breaking through. The BRT 2 Hitgolf disk-jockeys give Crabby Appleton's "Go Back" on Vogue an extra plugging. The record is expected in the BRT National top 30. Polydor released the LP's "Cucumber Castle" (The Bee Gees) and "The Who Live At Leeds." What a pity this last LP has not its original cover. Barclay will release all its home-made productions on the Triangle label. The company organizes a competition "Op zoek naar nieuw talent" (In search of new talent).

Gramophone released John Phillips' "Mississippi" on Stateside. It is promotion girl Els Van den Abeele's favourite record. Further releases are "We gotta do something new" (The Wallace Collection), a track from their second LP, B.J. Thomas' first LP on the Scepter label, "Sing brother sing" (Edgar Broughton Band) and "Deep Purple In Rock" on Harvest. The Greatest Show on Earth have a hit with "Real Cool World." This success is due to Beat-O-Rama's Etienne Smet. Monopole Records will distribute the Dutch label Blossom. The first record released is "She Was Naked" by the Dutch group Super Sister. Further Monopole singles are by Big Wheel and Fun of It. The company has a hit in Belgium with Anja's "Op het strand van Cadzand." Inelco reports that Duke Ellington will be in Oostende on August 1st. He will do one concert. The newest Inelco singles are "The

Wonder Of You" (Elvis Presley) on RCA and "A Time For Love" (John Rowles), "Do The Funky Chicken" (Willie Henderson), both on MCA.

Polygram does a great promotion for "Let Us Pray Together" by the Dutch duo Sandra and Andress. Roger Whittaker entered the BRT National top 30 with "I Don't Believe In If Anymore." Knokke member Truus has a new single out: "Een rozerode appelboom," the Flemish version of "Ein roseroter Apfelbaum." CBS-Artone general manager Pascal Robieffroid's daughter married a CBS promotion manager. On this occasion a party was organized for the press and the customers. Special guests were Marie Laforet, Michel Fugain and Joe Dassin. Fonior released the newest single by Ten Years After entitled "Love Like A Man." A new LP for Mary Porcelijn: "Mary Porcelijn zingt Boris Pasternak."

Palette news: Gillespie from the company W. and G. visited Brussels. He is Palette's representative in Australia and will release the series "Hurrah" and the artist Nico Gomez. Also Mr. Kulakowski from Carinia in Australia visited Brussels. Will Tura recorded a new single and prepares a production of two English titles for Kapp Records. This as a result of his visit to the U.S.A. Luigi started for Paris. He will sing "Un chant d'amour" in the TV-show "Midi Magazine." Joe Berluck has a new single entitled "The Erotic Voice." New LP's by Jimmy Camble and The Mertens Brothers. The new group El Chiclos released their version of "Viva Tirado." The J.J. Band started for a one month tour in Denmark.



**NAMELESS IN LONDON** — Ex-Bee Gee Vince Melouney has formed a new group (as yet unnamed) and signed a five year world-wide contract with MCA U.K. both as producer and artist. Present at the signing of the contract Brian Brolly, managing director of MCA U.K., Vince Melouney and group and Dorris Land, U.K representative of Cash Box.

## Belgium's Best Sellers

This Last  
Week Week

1	4	Yellow River (Christie—CBS—Eurovox).
2	1	Keep On Smiling (James Lloyd—Supreme—Intermission).
3	3	Question (The Moody Blues—Threshold—Essex Paris).
4	2	Up Around The Bend (Creedence Clearwater Revival—Liberty—Eds. Granit de Paris).
5	14	Kitsch (Barry Ryan—Polydor—Belinda).
6	10	Never Marry A Railroad Man (Shocking Blue—Pink Elephant—Primavera).
7	9	Ruby Is The One (Earth & Fire—Polydor—Primavera).
8	8	Mademoiselle Ninette (Soulful Dynamics—Philips—Benelux).
9	5	American Woman (Guess Who—RCA—Universal).
10	6	Cecilia (Simon & Garfunkel—CBS—World Music).



RADIO — TELE — LUXEMBOURG

# GRAND PRIX INTERNATIONAL 1970

RECORD PRODUCERS ARE INVITED TO  
SUBMIT ENTRIES FOR R-T-L's SECOND  
GRAND PRIX INTERNATIONAL

The Final will be held in Luxembourg  
on  
October 28th, 1970

This competition is open to all  
Producers in the principal listening  
countries to Radio Luxembourg.

The 12 Final Productions will receive  
massive exposure on all services  
of Radio Luxembourg throughout Europe

FOR RULES & DETAILS CONTACT:

- For Belgium (French Speaking) France and Switzerland (French Speaking)

M. Roger Kreicher  
Radio-Tele-Luxembourg  
22, Rue Bayard, PARIS, 8.

- For Belgium (Dutch speaking) & Holland

De Heer H.J.M. Terheggen  
Radio-Tele-Luxembourg  
11, Ave. Lloyd Georgelaan, BRUSSELS, 5.

- For Germany, Austria & Switzerland (German Speaking)

Helmut Stoldt,  
Radio-Tele-Luxembourg  
B.P. 163, LUXEMBOURG, G.D.

- For Great Britain & Ireland

Geoffrey Everitt,  
Radio Luxembourg (London) Ltd.  
38, Hertford Street, London, W1Y, 8BA

- For Luxembourg

M. Nic. Weber,  
Radio-Tele-Luxembourg  
B.P. 163, Luxembourg G.D.

## Argentina's Best Sellers

This Week	Last Week	Artist/Album
1	1	*La Cumparsita Alain Debray (RCA)
2	3	Como Has Hecho (Relay) Domenico Modugno (RCA)
3	2	*Se Te Nota (Ansa) Sandro (CBS)
4	6	Doblando La Curva (Up Around The Bend) Creedence Clearwater Revival (Liberty-EMI)
5	4	Cae La Lluvia Sobre Mi Cabeza (Melograf) B.J. Thomas (Trova); Soundtrack (EMI); Carlos Bisso, Sam Shay (RCA); El Comite (Microfon); Mel Williams (Odeon)
6	7	Con Amor O Sin Amor (Melograf) Luis Aguile (CBS)
7	10	*Cara De Sueno (Melograf) Los Naufragos (CBS)
8	8	*Paco Camorra (Kleinman) Septima Brigada (Disc Jockey)
9	17	Cecilia (Melograf) Simon and Garfunkel (CBS)
10	13	Sin Amor Tom Jones (London)
11	9	Espiritus En El Cielo Norman Greenbaum (Music Hall)
12	5	Venus (Korn) Shocking Blue (Polydor); Carlos Bisso (RCA); Sands (Disc Jockey)
13	—	*Un Dia De Invierno (Clanort) Palito Ortega (RCA)
14	18	*Yo Vivo En Esta Ciudad (Melograf) Pedro y Pablo (CBS)
15	12	*Muchacho De Blue Jeans (Relay) Tormenta (RCA)
16	20	*No Te Olvides De Recordar Pibe Estevez (Music Hall)
17	19	*Sentado En El Cordón De La Vereda Rolando Percy (Music Hall)
18	11	Let It Be (Fermata) Beatles (Odeon)
19	16	*Balada Para Un Gorso (Relay) Juan y Juan (RCA)
20	—	*Hace Una Larga Angustia (Ultramoderna) Roberto Vicario (EMI)
20	14	*Me Has Ensenado A Conocer Luis Aguile (CBS) *Local

This Week	Last Week	Artist/Album
1	1	Sotano Beat Vol II Selection (RCA)
2	2	Dedicado A Machado Joan Manuel Serrat (Odeon)
3	3	Led Zeppelin II Led Zeppelin (Atlantic)
4	10	"Z" Soundtrack (CBS)
5	4	Willy Y Los Ninos Pobres Creedence Clearwater Revival (Liberty-EMI)
6	5	Hey Jude Beatles (Odeon)
7	—	Butch Cassidy Soundtrack (EMI)
8	6	Festival De Festivales Selection (RCA)
9	—	Puente Sobre Aguas Turbulentas Simon and Garfunkel (CBS)
10	7	Dyango Dyango (RCA)

## CashBox Mexico

Deep grief among the Mexican public for Earl Grant's death. This performer's style remembered the late Nat King Cole. Earl Grant was well known in Mexico where he staged several times in the last few years as well as for his TV series. Now the videotapes are going to be used in a special program in his memory, this will be the Mexican TV homage to a great entertainer. DISCOS ORFEON just released Earl Grant's latest LP.

We regret that the Wilson Simonal's TV shows are not as good as they should be, specially when compared with his night club appearances. As we reported before, his stage projection is terrific, with a very well balanced program and a perfect handling of himself. On TV he has not been able to fully communicate his talent to the audience. The reason may be that the studio is packed with the wrong audience. It's a pity that the TV grand audience can not enjoy the real Wilson Simonal.

Before an audience of 20,000 people at the Agustin Lara Open Theatre in the Alameda Central, Canned Heat and The Rocking Foo were received with extremely warm applause. We must report that after Raphael this has been the second largest audience for the place.

ORFEON-VIDEOVOX Int'l Division released this week 3 very interesting EPs. "La Musica Original de la Pelicula Los Amores de Isadora" from KAPP; "Dionne Warwick," and "Holly Holy" with Neil Diamond from SPENCER. The LP release was "Favoritas con Pete Fountain" on CORAL with numbers such as "Raindrops Keep Fallin' On My Head," "Early In The Morning," "Jean," "Leaving On A Jet Plane" and "Midnight Cowboy."

As Cash Box fores it, Marco Antonio Muniz's "Nadita de Nada" on RCA, is on its way to the top of the charts. Other product of the same label having good sales are "El Primer Amor" with Angelica Maria; "Senorita Rita" with The Archies; "American Woman" with The Guess Who; "Mira" with Estela Nunez and "The Wonder of You" with Elvis Presley. As to the A&M

Records product we must mention "The Letter" with Joe Cocker; "Come Saturday Morning" with The Sandpipers and "Close to You" with The Carpenters.

For the way he handled himself on the stage, Wilson Simonal's El Dorado debut was quite a success. Repertoire consisted of the expected Brazilian beat, particularly outstanding were his "Si Voce Pensa," "Zazueira" and "Pais Tropical." Wilson Simonal's reason to be in Mexico beside his night club engagement is to cheer up the Brazilian foot-ball team taking part in the IX Football World Championship.

Organ player Juan Torres, who records for DISCOS MUSART, gave a highly successful concert at the Guadalajara Hilton (over 1,500 people). In celebration of such a success Casa Pedro Domecq and DISCOS MUSART hosted their largest press conference/cocktail yet. According to Jesus Acosta, Discos Musart top exec, Juan Torres has been a top seller through each of his nine LP releases.

Jose Jose creator of such hits as "La Nave del Olvido" and "El Triste" is cutting for RCA a new LP with numbers by Armando Manzanero, Arturo Castro and Roberto Cantoral. Jose Jose who is getting ready to stage Buenos Aires in a couple of months, will do, in the mean time, personal appearances in Los Angeles, Chicago and New York.

Luis Demetrio, the well known composer/chanter joined RCA's catalog. His debut on this label is a single with two of his latest songs "Palmaditas" & "Guadalupe." Another forthcoming RCA release will be the latest of Perry Como. The English version of "Somos Novios" by Armando Manzanero.

Raul Bejarano, sales general manager of CBS/COLUMBIA INT'L, was host for the press people at a cocktail reception to introduced Victor Blanco Labra, the label's new publicity manager.

## CashBox Argentina

Phonogram's artists Duo Salteno and Gustavo Leguizamon are preparing a music show that will comprise the several musical styles from the Northern part of the country, along with poetry by Manuel J. Castilla and Miguel Angel Perez. The show will be premiered at the Rivera Indarte theater, in the city of Cordoba, and afterwards brought to Buenos Aires to be presented at an undisclosed theater, probably the IFT. The Duo Aalteno is also preparing his second LP for the diskery, and is fulfilling public appearances at the Salamanca nitery, in Buenos Aires.

Odeon's Denis Dunn infos about the release of the new LP by Joan Manuel Serrat, but this time sung in Catalan language, the folk language used in the part of Spain where he was born. There is also a new LP by Uruguayan folk chanter Zitarrosa, recorded in Buenos Aires, and two LP's by Tom Jones: his latest "Tom" and the album recorded live at Las Vegas.

Music Hall's Luis Calvo sends word about the contracting of vocal group Buenos Aires Ocho by channel 7, for appearances at the "Argentinisima" music show emceed and produced by Julio Marbiz. Argentine chanter Alberto Cortez travelled last week to Spain, after a couple of months in Buenos Aires, for performances on Spanish TV, consisting in two special programs; the diskery has released the second volume of his "Poems and Songs" series, with works by Latin American poets.

EMI's Juan Carlos Mena reports that the Belter label, whose representation right were obtained a few months ago, has been a strong success in several markets of the interior of the country. EMI is working mainly on Victor Manuel and lark Salome, whose recordings are very popular in Europe. Several albums from the catalog are also appealing to the Spanish colony living in Argentina.

RCA's Garbarino sends word about the recording of an LP by Astor Piazzolla, one of the leading arrangers and musicians from this country, live at the Regina Theater. The diskery is also receiving this week the visit of the executive VP of the RCA Records Division, R. Laginestra, who is coming to Buenos Aires for talks with the top execs of the local branch.

CBS is releasing the first album recorded by the Cuarteto Zupay for the diskery. The group will start, during July, August and September, a tour covering the Northern part of the country, recording immediately its second album. On the international side, the top sales are going on Simon and Garfunkel's recent "Bridge Over Troubled Waters" album, which appears this week in the charts.

Fermata's Mauricio Brenner infos that there is a new single by chanter Giorgio, "Moody Trudy," and another one by Mina, under the PDU series: "Una Sombra." The diskery is also outing an LP by The Exotic Guitars, cut by Ranwood in the States, and another LP by French chanter Sacha Distel.

## Mexico's Best Sellers

This Week	Last Week	Artist/Album
1	1	Raindrops Keep Fallin' On My Head—B. J. Thomas—Scepter
2	4	Cotton Fields—Creedence Clearwater—Liberty
3	2	Te He Prometido—Leo Dan—CBS
4	3	*El Triste—Jose Jose—RCA
5	9	Spirit In The Sky—Norman Greenbaum—Reprise
6	5	*Te Regalo Mis Ojos—Maria Del Rayo—Peerless
7	6	*Besando La Cruz—Marco A. Vazquez—Peerless
8	8	Concierto Para Una Voz—Saint Preux—Gamma
9	—	*Nadita De Nada—Marco A. Muniz—RCA
10	10	*La Nave Del Olvido—Jose Jose—RCA

\*Local

## Montreaux Classics Awards This Sept.

MONTREUX — Given for the third consecutive year and sponsored by the Montreaux Music Festival, the Montreaux International Record Award will be granted again this year. An international panel of jurors will convene in Montreaux from Sept. 5 to 8; they are coming from the United States, England, France, West Germany, Switzerland, Belgium, Sweden, Italy, Czechoslovakia and Argentina.

This Record Award is considered unique: the only one to be sponsored by a long established, respected Music Festival, awarding only three recordings without consideration of categories (Symphonic, Operatic, Chamber music etc . . .) and without any commercial consideration.

A Preselection Committee composed of the specialized record critics all over the world is preparing the task of the jury, sending a preselection list of the best recordings (10) issued in their respective countries. A list of 20 titles has been made after all the preselections lists by the Chairman of the Preselection Committee (in addition to that list, each juror has the right to add one disk of his choice).

The Jury is granting a Citation for special achievement, entitled Diplome d'honneur, to a personality (engineer, musician, producer, executive of a company) having significantly contributed in the course of his activities towards progress in the world of recording. 1968 citation was granted to Leopold Stokowski; 1969 to Walter Legge.

## Airplane To U.K.

NEW YORK — Jefferson Airplane, top RCA recording group, arrived in London June 22 for a headline concerts at the famed Bath Festival last Sunday (28), preceded by the Rotterdam festival on June 26.

Also featured at the "Bath Festival of Blues and Progressive Music '70" will be rock groups Led Zeppelin, The Moody Blues, Steppenwolf, Frank Zappa, The Byrds, The Flock, Santana, Dr. John the Night Tripper and Country Joe and the Fish.

Before embarking on their European trip, Airplane members Jack Casady, Jorma Kaukonen, Marty Balin and Joey Covington will start production of their second "Hot Tuna" LP. The first "Hot Tuna" album, featuring Casady and Kaukonen, will be released in England by RCA next week. Jefferson Airplane's new single, "Mexico", was released this week in the U. S.

## Wallichs At EMI Meet

HOLLYWOOD — Glenn E. Wallichs, chairman of the board, Capitol Industries, is in the United Kingdom attending a Board meeting of Electric and Musical Industries, Ltd., London.

His itinerary also includes a visit to EMI's subsidiary, Pathe Marconi, Paris. EMI is the largest record manufacturer in the world. The firm owns more than 70 per cent of Capitol's stock.



## NEWS FROM HOLLAND

For the second time The Cats will be given a golden disc, for their LP "Colour Us Gold." They received their first Golden Disc for their album "The Cats." It is the first time in Holland a popgroup receives two Golden Discs for Albums. Their single "Marian" is released in America on the Rare Earth label. Dutch top group Brainbox released a new single, "Alpha And Omega," which is rising fast on the Dutch charts. "Alpha And Omega" will be released in America on the Capitol label. In September this year a tour is planned for Brainbox in the U.S. Dutch pop music is getting more and more popular all over the world. Capitol Records will shortly release "My World Is Empty" by The Buffoons, "Wait For Summer" by Allondee and "Please Sing A Song For Us" by The Continental Uptight Band. Bell Records will release the new single "Heartaches And Sorrow" by Unit Gloria. The group recently paid a visit to America where they had a successful performance in the Hollywood Palladium.

Bovema's aggressive attack on the progressive pop market with a special series called "Hey June" is very successful. Big LP hits are Canned Heat, Brinsley Schwarz, Steppenwolf and the promotion sampler "Hey June" with songs of Dutch top groups. Bovema recently welcomed in Holland Brinsley Schwarz for VPRO-TV and The Johnstons for VARA-TV. Phonogram released several strong chart-items last week: the football song "Chelsea" by Stamford Bridge (Penny Farthing), Octopus "The River" (Penny Farthing), Mr. Bloe's British smash "Groovin' with Mr. Bloe" (D.J.M.), "All Right Now" by Free (Island) and the Deram single "Love Like A Man" by Ten Years After. Roger Whittaker has a giant hit again in Holland with "I Don't Believe In If Anymore" (Philips—a Lansdowne recording). The record zoomed to No. 26 on last week's charts. The Alan Price recording of "Sunshine & Rain (Decca) is No. 24 this week, while Alan is topping the bill on the "Eddy Ready Go" TV-show next week. Phonogram rush-released a first album by Eurovision winner Dana. The Irish singer had a big seller with "All Kinds Of Everything," which is also included on the Album (Rex). The first Island single by Cat Stevens, "Lady d'Arbanville" has currently top-airplay on all stations. The record (taken from the "Mona Bone Jakon" album) will be one of the big sellers of the year without doubt. It was rush released by Phonogram last week.

Following the 25th anniversary of the Dutch Swing College Band in May, Phonogram released four re-packed albums of the internationally famous band. "Dixie Jubilee" features the best recordings from 1949-'69. "Gems Of Jazz" includes many of the famous 1949-'53 recordings. Both "At The Berlin Sport Palast" and "When The Swing Comes Marching In" are more recent albums of the D.S.C. Band. Though boogie-woogie music is not particularly popular in Holland, the albums of Dutch boogie-pianist Rob Hoeke are bestsellers for many years already. Hoeke normally leads his own R&B group, but frequently records boogie albums with pick-up groups. Phonogram released Hoeke's latest product, "Racing The Boogie" last week. Both his boogie and R&B albums are on the Philips label.

Last week James Lloyd appeared on the Willem Duys-program "De Vuist" with his hit "Keep On Smiling." Ariola-Benelux will also give strong promotion to the new Apocalypse single "Reflections Of A Summer." Their first single "Little Little," which got good review in the U.S.A., is still going strong here. The Avco Embassy group Liquid Smoke will reach very high on the charts with the single "I Who Have Nothing," released together with their hit album.

Barclay singing star Mireille Mathieu did three concerts in Rotterdam, The Hague and Amsterdam last weekend. Duke Ellington and his orchestra did an Amsterdam concert last Sunday at the 5000 seater RAI Building. CNR's shot of the year is an eighteen minute single with the reportage of the European soccer-final between Glasgow Celtic and Feyenoord (Rotterdam). With sales over 20,000 this record was in the Top 10. Last week CNR's close harmony group The Rowdies' first album has been baptized. It was Dutch golden artist Gert Timmerman who offered the LP "Friends" to the five members of the group. With the decline of soul music on the Dutch market Rotterdam's Soul Sound changed its style and released on CNR Records its first hard-rock single "My Mind's Phantasy." New name of the group: Rabbit Food. Like a tornado, Buddah's "Up With The People," the American musical-rock phenomenon, stormed over our country. Concerts were given in Amsterdam, Rotterdam, The Hague, Utrecht and Apeldoorn. The Dutch audience was very enthusiastic and the ones who did not have the opportunity to see the show must watch television on July 10th for the half hour show "Up With The People."

Holland was the first country American singer Melanie became a star in. Her albums "Born To Be" and "Back In Town" are Golden ones while her singles "Beautiful People" and "Lay Down" have been top ten hits over here. Barclay/CNR released a new single from Melanie's longplay "Candles In The Rain": "Look What They've Done To My Song/Ruby Tuesday" is a double-hit record. Another great Buddah group is the Edwin Hawkins Singers. They started here last year with their million seller "Oh Happy Day" and their popularity improved a lot with their appearance in Holland in February last. The live album "At The Concertgebouw Amsterdam" is a massive seller from which Barclay/CNR took the track "Praise Him" for a single record.

Norman Greenbaum and his producer Erik Jakobsen arrived in Amsterdam to appear in NCRV TV's "Eddy, Ready, Go" show. Norman's new single will be issued on the Reprise label within two weeks: "Canned Ham."

Crabby Appleton is getting strong radio-exposure with its first attempt for the Elektra label: "Go Back." The record is about to enter the Dutch charts and will be followed as soon as possible by the group's first album.

Dutch group Spacetrack has gained until now only international acclaim. At Least they are achieving national popularity here with their new Negram released single "She's So Fine." It's already on the air, while Radio Veronica has tipped it for the charts. Last week Negram unveiled Warner's Valiant album series including a great number of impressive mid-priced LP's by Fats Domino, Alan Sherman, Everly Brothers, Ike & Tina Turner, a.o. Negram is very pleased with this development and has the Warner/Reprise catalogue winning on three fronts now. The labels have a share of over 10% of the hits in Holland, has proven to be a very "Creedy" album seller and is now expanding in the "attractive" price field.

Elbert van Zoeren reported great activity at Holland Music N.V.: Barry Hopkins ("Love Ya, Want Ya, Need Ya" on Spark Records) was in Holland to appear in the very popular TV program "Eddy, Ready, Go" and for Radio-appearances. Two Italian songs, Dutch copyright by Holland Music were recorded in Holland: "Canzone Blu" (Wat Ziet Ie Blauw) by the Cocktail Trio on CBS and "Nevicava A Roma" by Willy Alberti on Philips. The theme song of the World Football Cup TV series "Guadalajara," a Holland Music copyright, was recorded with Freddy Golden on Philips.



**WHICH WITCH IS WHICH** — John Dyer, marketing manager of A & M Records; Alex Sanders, king of the witches; his wife Maxine; Tom Grantham, marketing director, Pye Records; Larry Yaskiel, European director A & M Records; are seen together after the reception held to launch Alex Sanders' record "A Witch Is Born" on A & M Records.

## Holland's Best Sellers

This Week	Last Week	Title
1	1	Question (Moody Blues/Threshold) (Essex—Basart/Amsterdam)
2	4	Kitsch (Barry Ryan/Polydor) (Belinda/Amsterdam)
3	2	Never Marry A Railroad Man (Shocking Blue/Pink Elephant (Dayglow Music/Hilversum)
4	6	Yellow River (Christie/CBS) (Anagon/Heemstede)
5	9	Real Cool World (Greatest Show On Earth/Harvest) (Dayglow/Hilversum)
6	3	Up Around The Bend (Credence Clearwater Revival) (Basart/Amsterdam)
7	—	She Was Naked (Super Sister/Blossom Records) (Dayglow/Hilversum)
8	8	The Green Manalishi (Fleetwood Mac/Reprise)
9	—	Lucy Lucy (Amsterdam/Polydor) (Dayglow/Hilversum)
10	5	American Woman (Guess Who/RCA) (Universal Songs/Amsterdam)

## Kruize Of Bovema Praises Capitol's New Talent Thrust

HEEMSTEDE — Roel Kruize, general label manager for Bovema-Holland and repertoire coordinator for EMI in the German countries, returned from a U.S. trip. His main object was attending the Capitol Convention in Hawaii. Kruize told Cash Box: "Capitol's convention was a great experience and a pleasant surprise, because I got the feeling they seriously are paying a lot of attention to one major fact, essential in the growth of a record company, such as finding and developing new talent. Capitol did so and I am very glad to state that a lot of good artists with excellent material will come up in the near future. They reorganized a lot of departments during the past year and coordination between A & R and marketing really knocked me out. Capitol's merchandising projects presented during the convention were of very high standard and I was very pleased with the philosophy behind it. We, doing Capitol in the European territories, also got the feeling that they are expanding their international efforts. That they are going to use their experience and talent on a wider scale will benefit all of us!"

Kruize, being asked for an example that Capitol's future indeed is developing today, stated: "Sal Iannucci, president of Capitol's industries, is playing records every day. I like a top executive playing records because doing so he knows today what his people are going to sell tomorrow!"

"Further, I had some very good talks with A & R director international Don Shain. The Dutch are also coming on Capitol now. They really are behind our groups and within a short time first records will be released of Brainbox, Buffoons, Continental Uptight Bnad and probably more."

## Klein In London

NEW YORK — Allen Klein, president of ABKCO Industries, is in London for a series of business conferences concerning his clients who include The Beatles, The Rolling Stones, and the upcoming ABKCO Films production, "Come Together," starring Tony Anthony, Luciana Paluzzi and Rosemarie Dexter.

## Larry Douglas Inks Prod. Deals

LONDON — American independent producer Larry Douglas, of the Larry Douglas Productions, has entered into a three year contract deal with the record firms, PDU, owned by Italy's top recording artist, Mina, for Italy and Switzerland; German Vogue Records, for Germany, Austria and the Benelux, excluding the artists the Dorians, for the Benelux, for they are represented by EMI-Bovema on its Stateside label for Holland and Benelux; for the United Kingdom, Embers Records, Ltd.

Via this deal, these firms will have access to all new material produced by Douglas, which includes the Detroit based group, The Dorians, whose new release of "Psychedelic Lipstick" backed with "Good Love" is now released world-wide by PDU Records for Italy and Switzerland; German Vogue Records for Germany and Austria; French Vogue for France, French territories and former colonies; EMI-Bovema-Holland on its Stateside label, for Holland and Benelux; and Discophon Records for Spain. With Discophon Records, Douglas has signed a one record deal with the firm for the Dorians, leaving the door open, for another major Spanish firm to join the ranks of the Larry Douglas Productions in a three year contract deal.

Douglas is now negotiating with Philips in Beyrouth, Lebanon, for the Dorians and other artists in the Larry Douglas Productions, for the Middle East.

EMI — For the World — is representing the Larry Douglas Productions for Australia, New Zealand, Japan, Singapore, Malaya, The Philippines, South Africa, Rhodesia, etc.

They will tour and play Europe this fall, by opening in Italy.

# "PSYCHEDELIC LIPSTICK" and "GOOD LOVE"

THE INTERNATIONAL HIT SONGS FROM:  
**DETROIT / MICHIGAN / U.S.A.**  
SUNG BY: THE INTERNATIONAL HIT ARTISTS FROM:  
**DETROIT / MICHIGAN / U.S.A.**

**"THE DORIANs"**  
"PSYCHEDELIC LIPSTICK"  
"GOOD LOVE"  
BY THE  
DORIANs



JOHN UNGER / BILL LOOP / MIKE BUTTS / BOB NIXON  
**"THE DORIANs"**

RELEASED ALL  OVER THE WORLD

*In Italy and Switzerland on*  
**PDU-RECORDS \***  
#P.A. 1036

*In Germany and Austria on*  
**VOGUE RECORDS**  
#D.V. 11080

*The Netherlands and Benelux*  
by *EMI-BOVEMA*  
On **STATESIDE RECORDS**  
#5-C006-91604

*In the United Kingdom and Eastern Europe by*  
**EMBERS RECORDS**  
#EMBS-285  
"Help For My Waiting"

*In France, The French Possessions,  
Territories and former Colonies on*  
**VOGUE RECORDS**  
#D.Y. 11080

*In Spain on*  
**DISCOPHON RECORDS**  
#S.5. 104

Recorded at GM Studios East Detroit, Michigan

\* PDU-RECORDS is the label that MINA,  
Italy's number one recording artists made famous

**Larry Douglas Productions (USA)**

FOR EUROPE / AFRICA / ASIA / AUSTRALIA / UNITED KINGDOM  
POST OFFICE BOX 265 / RADIO CITY STATION / NEW YORK, N.Y. 10019  
LARRY DOUGLAS PRIVATE EUROPEAN ADDRESS:  
6 RUE DE L'EGLISE-92-NEUILLY, FRANCE



Among new appointments within the industry is a joining of a top administrative head and A&R man for Compo's new Product Development and Sales Marketing division. Taking equal shares of the new chores are Lee Armstrong, former manager of Apex Division and Ronnie Dykhof, producer of several French Canadian and English Canadian groups for Compo. Some of these include Sebastian, who is now making chart gains with his Apex deck "Back In Love Again;" Quebec's Les Coquettes; and John Allan Cameron. Also from Compo, Gordon Morrison has joined the company as Quebec promotion man. He'll look after promotion with the English Canadian stations in Quebec and the Ottawa-Kingston area. Morrison was formerly associated with Thomas Rathwell Ltd., Compo's Manitoba and Saskatchewan distrib.

London Records has upped Ken McFarland to the post of Ontario sales and promotion manager with Joe Toews taking on duties as Ontario operations manager.

New national promotion manager for Ampex Tapes & Records is Martin McGinnis. He was a co-organizer of the first two College Entertainment Conferences at the University of Waterloo, later becoming a partner in Albert Groosman's management company, leaving in 1969 to work in New York for Chartwell Artists. He later formed his own management company in Canada which was just prior to his new appointment with Ampex. Initial promotion for McGinnis is the newest Ian and Sylvia single "Trucker's Cafe" culled from their album "Great Speckled Bird".

Keith Lawrence, manager of Vancouver's Collectors dropped by Toronto's Cash Box offices with news of a name change for the successful London recording unit. In keeping with the Canadian image, they've adopted the

name of Chilliwack, which happens to be the name of a small town up the West Coast of British Columbia. Lawrence was just returning from New York where the group had put the final touches on their A&R produced session. Their next single "Chain Train" will be released on the Parrot label. They are the only Canadian group on board this powerful UK label. Canada's Top Female Singer, Ginette Reno, also on Parrot, has made good gains with her new release "Crowded By Happiness." Latest single from London, a Ritchie York production, "Uncle Pen" by Crowbar, was produced at Toronto Sound Studios (formerly Revolution Sound). The "Dr. Tom" single by Montreal's Freedom on the Aquarius label, has picked up considerably across the nation. This single was a production of Chum's Much Music and although missing out of the Maple Leaf System, has managed to move up the Chum chart. Brian Chater, who heads up Chum's pubbery, Summerlead Music, and production house, reports the single has become an outstanding seller in Montreal with top exposure from CFOX. Chater also reports the single is to be released in the U.S. on Scepter and on Gamma in France. New signing for Much is the Halifax group, April Wine.

Ottawa's MRQ were given a very few hours notice to replace the Guess Who at Expo '70 (Osaka). The MRQ are managed by Harvey Glatt of Ottawa, who has also signed Canada Goose, currently making chart moves with their Tonsil lid "Flying High." This is the old Esquires group. Glatt has also signed David Wiffen, former member of 3's A Crowd. He's just returned from San Francisco and a recording session with Fantasy. The #2 man at Fantasy is former Quebec Branch Manager for RCA, Lee Mendel.

## Capitol Canada Presents Awards

Capitol Records (Canada) Ltd. presented seven awards and two certificates on June 18, climaxing five days of its National Convention 1970 at the Bayshore Inn in Vancouver. Convention theme was CHIMO, the warm friendly Eskimo greeting.

Guests included Anne Murray recently a guest on a TV pilot film with Ian and Sylvia called "Nashville North," Pierre Lalonde well known star of TV in Quebec; Joe South, Capitol artist recently seen on the Bobby Gentry CTV Special; and Gary Buck, general manager of Beechwood, a division of Capitol Records (Canada) Ltd.

Awarded to the branch in the Capitol rack division was Moncton New Brunswick. Jim MacLeod, branch manager, accepted the silver rose bowl from Bud Farquharson, national sales manager of the rack division.

Douglas Hadden of Vancouver received the rose bowl award from Bud Farquharson. This is the first time Capitol has presented these awards to the Rack Division.

Top salesman from Vancouver, Uwe Schnack won the sword for concern for his customers and company.

Paul White, director of A&R, received an award for his work and direction with the Edward Bear Group.

Hal Schatz, director of advertising and promo, was given an award for his division's effort in publicizing and promoting Edward Bear.

Edward Bear received an award for being the first group to break in the United States as a Capitol Canadian International Artist.

Pierre Lalonde received an award for his hit song Caroline which sold over 50 thousand singles in Quebec.

Certificates were given to last years winners as a momentum of the past years efforts for 1968-1969. Dave Evans, former Ontario branch manager, received one for his branch and Bill Rotari, Quebec sales manager, for being salesman of the year 1968-1969.

## Plumb's 'Fiddles' LP To EMI Dist.

LOS ANGELES — IMC Productions has granted EMI distribution rights to Neely Plumb's "Funky Fiddles" album for the United Kingdom and other world-wide outlets.

Plumb has just returned after completing recording the instrumental album in London. EMI is rush releasing a single from the LP, "It's All In The Game" backed by "Happy Sad Song," a Plumb original.

"Funky Fiddles" is an album of motion picture scores and rhythm and blues hits arranged in a special way by Plumb.

IMC Productions and EMI have a releasing relationship whereby American production company provides EMI with eight LP's and a number of singles each year for three years. Lenny Poncher, co-owner of the company with Bill Loeb, negotiated the deal last December.

While in London, Plumb also completed recording the instrumental music he wrote for Anthony Newley's interpretation of Jennings Cobb's free form love poem, "For You." IMC has not yet set any distribution arrangement for this album which it has financed. Newley recorded his vocal readings in Los Angeles, so Plumb knew exactly how many minutes of music were required before he went into the London recording studio.

In his role as Capitol Records exclusive soundtrack LP specialist, Plumb visited a number of European film companies anent securing film music.

Among the films he investigated were "The Young Cassanova" with a score by Fiorenzo Capri (starring Leonard Whiting of "Romeo & Juliet" distinction); "Waterloo" with a score by Nino Rota; "Brother Son, Sister Moon" with a composer yet to be assigned. These films were all being prepared in Italy.

In England, Plumb saw "On This Rock," a documentary based on St.



PROPHEYSING THE FUTURE — Tony Reeves, recording manager, Colin Richardson, general manager of Bron Artists Management, Mickey Shapiro, president of the American company, Prophecy Records and Ian Ralfini, managing director of Warner Bros. Records Ltd. seen together at a party given by Mickey Shapiro. Shapiro was in London to meet British record company executives to arrange a distribution deal for his new record label, Prophecy.



## CashBox Germany

On July 10, Frederick Loewe, composer of "My Fair Lady," celebrated his 69th birthday in the Hamburger Hotel. Loewe had reckoned out that he must have been "made in Hamburg" when his father at that time was guest star in Hamburg, but he was born in Vienna. This birthday party was arranged by the best seller author Harold Robbin, who's new novel "Die Bosse" is being printed in the German magazine Stern, and by Juergen Otterstein of Polydor/Antenna. Only a few German journalists and artists were invited. The American TV actor Raymond Burr, who is on a goodwill tour through Europe and well known here from his TV series as criminal chief "Ironside," made a surprise appearance.

The Grand Prix Eurovision de la Chanson 1971 will probably take place in Dublin Ireland next March. 12 countries will participate . . . Larry Yaskiel, A & M director for Europe in London, was in Munich. It was leaked out in the German trade the distribution of A & M, until now done by Polydor, perhaps shall be overtaken in autumn by Ariola/Eurodisc . . . In June the Hansa Musik Produktion starts a special promotion and sales campagne for Dutch pop music. After the great success they had with the Tee Set and the George Baker Selection they are going to bring more Dutch bands on the German-speaking market. Under their emblem appearing on all covers of the Dutch bands, a rising sun with the text "Dutch pop — the new way in the top," five bands will be introduced in June. All recordings of the Dutch pop-series are stereo recordings. Thus, the Meisel Brothers give you a survey of the happenings in Dutch pop-music. At the same time a Dutch pop lotto will be arranged for the professional circles when they will guess the placement of the best selling bands . . . The kings of Limbo, "The Peanuts Taylor Group," came from the Bahama Islands to Cornet Music GmbH, Cologne. The reason for the recording of the WestDeutscher Rundfunk transmission "Variete'-Zauber" which will be broadcast on the 8th of August. Cornet will publish in a near future the first record by this fantastic group titled: "Chi Chi Merengue"/ "Island Woman" . . . The publishing house B. Schott's Soehne, Mainz, managing directors, Ludwig Strecker and

Heinz Schneider-Schott, celebrated their 200 years jubilee. The repertoire of this famous publishing house reaches from Beethoven over Richard Wagner to the contemporary European

. . . Edition C.F. Peters, Frankfurt, published for the first time an opus of Franz Schubert, the "Ouvertuere c-moll fuer Streicher." This is one of the earliest Schubert compositions which is complete . . . Press chief Wolf Bruemmel of Electrola invited journalists from the whole of Germany to come to Berlin on the 18th of June to an English breakfast together with Cliff Richard. Occasion was the recording of a Cliff Richard show by the Sender Freies Berlin . . . "music 2000," a subsidiary company of Deutsche Grammophon, plans to publish the Beethoven edition of the Deutsche Grammophon Gesellschaft on about 70 MusiCassettes . . . The German trade journal "Automatenmarkt" will lead a contest of which German speaking hits in the first half of 1970 were the favorites in the juke boxes. Until now the succession is: 1. Roy Black with "Dein schoenstes Geschenk," 2. Christian Anders with "Nie mehr allein" and 3. Michael Holm with "Mendocino." . . . Hermann Zentgraf, production chief of CBS in Frankfurt, took the English singer Mike Brent under contract for several years. Brent, a new discovery of the last Midem in Cannes, will sing on his first German record two titles by the successful composer Hans Blum, who has also taken over the production . . . The big German youth magazine Bravo, which is charged with the alignment of the 24 final choices of the "World Teen Princess" has determined that this festival will take place in Berlin on July 18-25.

## Ampex Videotape Center In Germany

NEW YORK — Ampex International has established a videotape duplication center in Boeblingen, Germany, to serve the growing European closed circuit television market. According to B. A. Olerich, group vice president, the purpose of the new center is to provide any number of duplicate monochrome videotape copies of master programs for closed circuit television users in education, medicine, business and industry.

Copies in the Ampex one-inch videotape recorder format will be supplied from master tapes recorded in either the broadcast standard two-inch tape format or the Ampex one-inch format. Tapes produced on any Ampex one-inch recorder can be played back on any other Ampex one-inch recorder.

The center also is equipped to edit electronically several master tapes into a single taped program, Olerich said.

Peters Basillica with a Michael Lewis score. Plumb has been talking to Capitol's special products department about this LP. He also discussed an LP for "Say Hello To Yesterday" which has a Riz Ortolani score.

Before leaving for Europe, Plumb's last domestic assignment for Capitol was the completion of the "Norwood" soundtrack package starring Glen Campbell. Plumb had also produced Campbell's "True Grit" LP.



## EDITORIAL:

### The Professional Operator

At this time, when all eyeballs are focused on the dollar, it's almost impossible to believe there are still hundreds of thousands of people in this country who take greater pleasure from what they work at than from the money they make doing it. This is especially true in artistic circles . . . composers, actors, writers, and such, although everyone knows people who are quite satisfied in whatever little niche they may sit, be it the Post Office or behind the counter of a coffee shop.

Before the world learned that monetary currency provided a more convenient means of trading services and goods than bartering, people were measured by what they did rather than by how much they made. Folks chose careers on personal aptitude and interest and eventually became slick professionals. The better they became at making coffee kettles or shoeing horses, the more goods they could ask in return, and many got "rich."

Most of the successful music and games operators who populate this industry are professionals in the same sense. They make money from their routes because they are good operators, not because they're good money manipulators. This is an all-but-forgotten thought in this day of loans, gifts and other sky-rocketing operating expenses. It is almost impossible to conceive of an operator accepting a compliment from a location on the quality of his service and equipment without first thinking: "Hey, I guess I've got this place locked up." Shouldn't the first thought have been: "Hey, I'm doing a pretty good job."

Surely, the first priority at the operating company must be to present entertaining equipment to customers at the stops. After all, when Joe Doaks drops a quarter into the jukebox, the last thought in his mind is supporting your business. He's either happy with the good selection of music you offer or mad at the lack of it. He's either interested in playing your games or he ignores them. In both cases, the bad collections will clearly indicate what kind of job the operator's doing, **but**, if this is what you wait for before correcting the situation, you're not as professional as you think.

The professional operator takes pride in his work. He enjoys knowing his music boxes are cooking with great music, his games are banging away because they're so much fun to play, and his location owners are happy they deal with him because **he knows his business.**

We often talk of creating ways to keep machines out of the hands of the location, but there's one certain method too often ignored. Call it operating talent, coin machine sense or competent professionalism — the message is clear. First comes the product and then comes the sale.

### Brunswick Introduces Coin-Op 'CB-8'; 8-Footer With Basic Design of 'CB-7'

CHICAGO — The Brunswick Corp. recently introduced its new "CB-8" coin-operated billiard table, a four by eight foot table identical in design to the "CB-7" which measures three and one-half by seven feet.

The "CB-8" table has a registered one-inch thick, one piece precision ground bed, formica rails resistant to burns, a bed cloth that can be changed without removing the slate and snap-in cushions that facilitate service.

The coin box of the "CB-8" can hold more than \$250 in quarters and a non-reversible meter is optional. The table's wire track ball returns prevent clogging of the holes with debris as small particles fall through the track and larger pieces can be pushed out easily.

Brunswick regional representative Ron Bartos explained that the success of the "CB-7" made it unnecessary to develop major innovations in the "CB-8". "There's no need to change the design of the "CB-7" for our new table," he said, "because in the "CB-7" we did everything we could to make it acceptable from a standpoint of playability and durability."

Bartos also said that the "CB-8" is coming off the production line and is available for distribution through Brunswick distributors. He revealed that Brunswick expects to produce

a similarly-designed three by six foot table in the fall, intended for locations with limited recreation area and for those in locales where legal restrictions do not permit larger tables.

### Florida House Bill to Legalize Bingos Fails After FAMA Opposition Lobbying Effort

WINTER HAVEN — Florida House Bill 4755, proposing the legalization of in-line pinball machines, failed to gain passage during the recently concluded regular session of the Florida Legislature.

The bill, opposed by the Florida Amusement & Music Assn., was passed by a House committee but did not reach the House floor. FAMA president Wesley Lawson made two trips to Tallahassee where he and FAMA executive director Bob Rhinehart presented FAMA's position to the House Committee. After the bill's passage out of committee, it was removed from the special order calendar and consequently never reached a vote.

The FAMA says the pinball bill will probably be again introduced in 1971. FAMA expects the state legislature will attempt to raise two hundred million dollars of additional tax money in order to maintain the operation of the state government. According to

FAMA, governmental committee meetings will soon be held throughout the state that are likely to shape the tax future of Florida's coin machine industry. FAMA plans to step up lobbying efforts in an attempt to influence decisions that will be made concerning additional taxes on coin-operated equipment.

### MOA Distributes Stickers To Help Promote Expo '70

CHICAGO — The MOA is currently engaged in a mailing effort to distribute its pressure-sensitive Exposition promotion stickers which it hopes will help promote Expo Seven-O, to be held in October.

The stickers are intended for use on letters and other mailings and are free in any quantity from the MOA office here.

REALISTIC REVERBERATING SOUND      EXCITING MINE EXPLOSION



**Williams**  
**BONANZA**  
**RIFLE GAME**

ALSO DELIVERING LAGUNA & HIT AND RUN

**Williams** ELECTRONICS, INC.  
3401 NORTH CALIFORNIA AVENUE • CHICAGO, ILLINOIS 60618  
CABLE ADDRESS WILCOIN CHICAGO  
AVAILABLE FOR IMMEDIATE DELIVERY THROUGH YOUR WILLIAMS DISTRIBUTOR

**Peter Betti Finishes Undergraduate Career; Eyes Coinbiz Future**

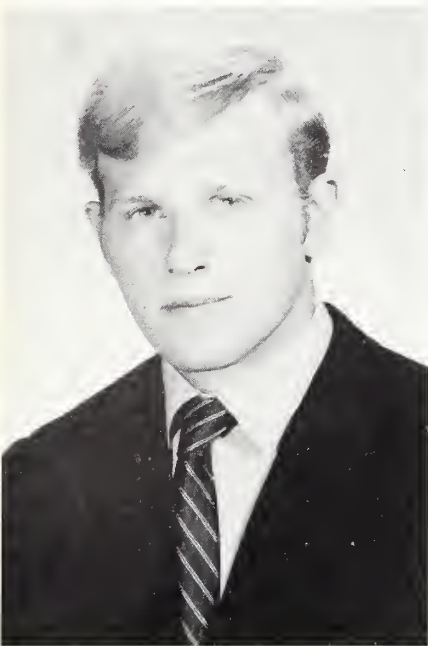

**PETER BETTI**

**NORTH BERGEN** — Peter Betti, son of Bert Betti, president of Betson Enterprises and associated companies, here recently graduated from American University in Washington, D.C.

Peter, who spent his summers at Betson, starting as a floor sweeper and currently working as a phonograph serviceman, completed his college career with several honors. He achieved the Dean's List, was president of Zeta Beta Tau fraternity, a member of several honor societies and captain of the rugby team, which he founded in his sophomore year. He capped his four years at American with his election to "Who's Who in American Colleges and Universities," and was chosen as American University's "Outstanding Fraternity Man in 1969-70."

Peter is currently waiting to be called for six months of active reserve army training after which he will pursue graduate studies in business administration. Discussing his post-scholastic plans, he says, "The coin machine industry offers a great challenge, is exciting, and offers great opportunities for the future. I hope to carry on in the tradition of my father and grandfather, Humbert Betti, Sr., the founder of the business."

**German Coin Exhibition Postponed Until 1971**

**BERLIN** — The International Coin Machine Exhibition, "ima 70," scheduled to be held here this year in October, has been cancelled. The supreme joint committee, AMA, which represents manufacturers and distributors of coin machines, voted to cancel the Exhibition because manufacturers, importers and distributors were opposed to another exhibition after the Hanover Fair, held in May.

The three AMA partners, who voted 2-1 for cancellation, also decided that "ima 71" will, however, be held in October next year at the Berlin Kongresshalle. The "ima 71" will be combined with German Coin Machine Day as have past "ima" exhibitions. The AMA hopes that the coin machine exhibits will be omitted from the Hanover Fair next year, which is a general trade show, thus endowing "ima 71" with an exclusive coin machine flavor where all types of games and amusement machines would be displayed.



**Location Programming Guide**

THIS WEEK'S TOP RECORD RELEASES FOR COIN PHONOGRAPHS

**Adult Locations**

- PAPER MACHE (2:56)  
**DIONNE WARWICK**  
No Flip Info. Scepter 12285

---

- IT'S GONNA CHANGE (2:40)  
**BOBBY GOLDSBORO**  
Down On The Bayou (2:55) United Artists 50696

---

- I'LL NEVER FALL IN LOVE AGAIN (3:02)  
**JERRY VALE**  
Lovin' Time (2:38) Columbia 45188

---

- BRING IT ON HOME TO ME (2:59)  
**LOU RAWLS**  
Can You Dig It/Take Me For What I Am (3:14) Capitol 2856

---

- LOVE IS ALL (3:27)  
**SERGIO FRANCHI**  
Here We Go Round Again (2:51) United Artists 50681

---

- I'LL PAINT YOU A SONG  
**MAC DAVIS**  
Closest I Ever Came (2:54) Columbia 45192

**R & B**

- DO YOU SEE MY LOVE (FOR YOU GROWING) (3:14)  
**JR. WALKER & THE ALL STARS**  
Groove And Move (2:53) Soul 35073

---

- MY GIRL (3:19)  
**EDDIE FLOYD**  
No Flip Info. Stax 0072

---

- GIRLS WILL BE GIRLS, BOYS WILL BE BOYS (2:30)  
**ISLEY BROTHERS**  
No Flip Info. T-Neck 921

---

- SET ME FREE (3:32)  
**ESTHER PHILLIPS**  
Brand New Day (4:15) Atlantic 19388

**Teen Locations**

- SUMMERTIME BLUES (3:22)  
**THE WHO**  
Heaven & Hell (3:31) Decca 32708

---

- SOLITARY MAN (2:28)  
**NEIL DIAMOND**  
The Time Is Now (3:10) Bang 578

---

- HEY BULLDOG (2:27)  
**BILL DEAL & THE RHONDELS**  
No Flip Info. Heritage 824

---

- IT'S YOUR LIFE (2:45)  
**ANDY KIM**  
To Be Continued (3:17) Steed 727

---

- HE'LL NEVER LOVE YOU (1:59)  
**THE GENTRYS**  
I Hate To See You Go (1:15) Sun 1118

---

- SLIP ON THROUGH  
**THE BEACH BOYS**  
This Whole World (2:00) Brother 0929

**C & W**

- BORN TO BE AN OPRY STAR (3:08)  
**GUY DRAKE**  
Politickin' Pete (2:40) Royal American RA-15AA

---

- HEAVEN EVERYDAY (2:33)  
**MEL TILLIS**  
How You Drink The Wine (2:42) MGM K14148

---

- THIS NIGHT (AIN'T FIT FOR NOTHING BUT DRINKING) (2:44)  
**DAVE DUDLEY**  
No Flip Info. Mercury 73089

---

- THAT AIN'T NO STUFF  
**COMPTON BROTHERS**  
I Wanna Sing A Country Song (2:22) Dot 17352

check your local One Stop for availability of the listed recordings

## EASTERN FLASHES

**AROUND TOWN** — Lots of cigarette operators and dealers were packing off for the 1970 Cigarette Merchandisers Assn. convench at Laurels in the mountains at press time. Weekend (26-28) should see many music and games operators and their families there . . . Coinrow dealers with can drink machines doing brisk business with this item now that summer is upon the trade. Unfortunately, not too many straight-line juke and games operators buying them. Still think this is one area that fits nearly perfect within this industry's scope . . . Affable Billy Whitcomb of Peach State's Columbia office and his charming wife Dorothy into New York City last week for brief vacation. They drove up from South Carolina to the city in just over six hours weekend before last and got in all the sights hereabouts (Circle Line cruise, etc.) before driving off again to Niagara Falls and then into Canada. While here, they shuttled over to the American Shuffleboard factory in Union City, N.J., met with Nick Melone and Sol Lipkin and took in a party in Union with Sol that night . . . Local ops enjoying new convention journal recently published by the three local associations, under the direction of Ben Chicofsky. Book looks great and would have been given out at the Bahama convention except that customs regulations made it too difficult to bring the books in. As many factory execs, who held sales conventions out of the country one time or another know, some countries pile a heavy duty on top of any printed matter.

**NEW ENGLAND NOTES** — Chatted with Irv Margold up at Trimount in Dedham, Mass. on the phone, shortly after he returned from Sol Gottlieb's funeral in Chicago Wed. the 17th. Irv said many coinbiz friends of Sol and the Gottlieb family were in attendance. Of those he immediately recalled seeing were Joe Ash, Hymie Zorinsky, Johnny Bilotta, Al Rodstein, and J.D. Lazar.

**THE JERSEY BOUNCE** — Arcades are bustlin' up and down the shore now and much of the new amusement equipment released since last fall is stage front at the games rooms and boardwalk "casinos". Heavy hitters are expected to be the electronic target and combat machines and racing games on quarter play. Dealers in the State also expect sterling action on the Baseball pin by Gottlieb, Bally's Space Flight astronaut game and the Zoltan horoscope game by Prophetron. The latter, operating on dime play, can book a consistent \$100 a week in a well-trafficked location. Here's to a good season for all . . . Brunswick's regional table sales rep Ron Bartos says Brunswick's new 8' coin table (CB-8) will probably be followed up in the fall with a 6' version, giving the company greater flexibility in selling its coin-op products to this industry . . . The United Billiards factory is now into production on a host of products. In addition to its coin table lines (which in combination of size and color cabinet colors available comes to 15), United's manufacturing and marketing a coin and non-coin 9' shuffleboard table called the 'Jet', and their recently introduced 'Jumbo' aluminum frame shipping dolly. To facilitate production line demands, the firm has leased another building nearby the headquarters plant on Progress St. in Union.

## UPPER MID-WEST

Our congratulations to the **Manolises**, Huron, on the marriage of their son **Steve** on June 6. Steve recently graduated from the University of South Dakota where he majored in business administration. He now has a position with the Kodak Co., Rochester, N. Y. . . . **Ron Manolis** ran for the School Board in the last election, but we don't know whether or not he made it.

**Mrs. Ted Salvesson** returned home from a month vacation in San Diego where she visited her sister . . . The **Porters** of Mitchell have their daughter **Cindy** home for the summer. Cindy attends school in Tuscon. Their son **Craig** and his family are also spending the summer with them . . . **Dar Holsman** and his son in town on a fast trip to pick up some equipment . . . **Phil Smith**, Minneapolis op, flew to South Bend and then to Bloomington, where he saw his nephew graduate from the University of Indiana.

**Earl Ackley** at a postmasters conventions for a week at Sturgeon Bay . . . **Johnny Cooper**, Duluth and **Nik Berquist** in town for the day buying equipment . . . **Bob Lucking** in the cities buying records and parts. So was **Cab Anderson** and his son **Kevin** . . . **Herb Peterson** and **Duane Reiners** in the cities for the day making the rounds . . .

**Ryel Gelineau**, back in the hospital after another heart attack. He was released five weeks ago, and feeling fine forgot his illness and tried chopping down a small tree. He's getting along fine and will be out in about two weeks . . . **Bob Guillaume** and his son in town for the day taking in a ball game . . . **Mr. and Mrs. Frank Mager** in the cities for the day . . . Lots of raves from ops on Gottlieb's "Baseball" and Williams' "Jive Time" and "Bonanza." . . . **Don Hazelwood** and **Don Jr.** in town for the day. Don Jr.'s wife and child are visiting her parents in New York.

## MILWAUKEE MENTIONS

Schlitz Brewing Co. will sponsor a huge July 4 circus parade which will be televised in various states across the country. Among participants in the gala event will be movie actor **Ernest Borgnine** and the **Ringling Bros. and Barnum & Bailey** entourage . . . New member of Empire Dist.'s sales staff is **Pat Netterville**, who's also a newcomer to the coin machine industry. Pat spends a great deal of time on the road covering the state of Wisconsin, the upper peninsula, and points thereabouts. Welcome aboard!

In addition to keeping up with activity at the busy Pierce Music operation in Brodhead, **Clint** and **Marie Pierce** are involved in Dairy Month (currently running) and the various functions held in conjunction with the big event. A Dairy Queen will be elected and a special "Cheese Day" will be held in Green County. The Pierce farm, of course, is a real showcase at this time!

Nice chatting with **Jim Stansfield** Novelty in LaCrosse. He and Jim Jr. attended the recent Minnesota Vending Seminar at Madden's Retreat in Brainard, Minn., which reportedly attracted a record-breaking crowd! Stansfield Novelty is enjoying a surge in business resulting from activity at the various resorts in the surrounding areas!

Got the word from **Gordon Pelzek** of Record City on some hot operator singles hereabouts. His list includes **Engelbert Humperdinck's** latest release "My Marie" (Parrot), "Close To You" by **The Carpenters** (A&M), "Drivin' Home" by **Jerry Smith** (Decca), "Eleanor Rigby" by **El Chicano** (Kapp) and "You Wanna Give Me A Lift" by **Loretta Lynn** (Decca).

## CHICAGO CHATTER

As of Friday, June 26, the Rock-Ola Mfg. Corp. plant closed for the annual two weeks vacation period. Factory will resume production on Monday, July 13. We understand, however, that a skeleton force will be on hand in the office.

Our condolences to Empire Dist. veepee **Joe Robbins**, whose father-in-law, **Phillip Hoffman**, passed away (21). Funeral services were held last Tuesday (23) and Joe's many friends and associates in the industry were present . . . "SAMI" continues to be a strong item out at the Midway Mfg. Co. plant in Schiller Park. Sales manager **Larry Berke** says "operators love the game and are especially pleased about the apparent lack of service problems involved."

No summer doldrums at Atlas Music Co. **Joe Kline** says all departments are busy — music, vending, games. The crew is already gearing itself for a five-day week, because the Atlas showrooms will be closed on Saturdays for the months of July and August. Get out the golf clubs, fellas! . . . The word "bonanza" is defined as "any rich source of profit", and this accurately describes Williams' current, "red hot" rifle game, according to **Bill DeSelm**. He says location reports reaching the factory bear out the definition. Also on the receiving end of operators' praise are "Laguna" and "Hit & Run", which are both on the current Williams' delivery schedule.

**Ted Rubey** and the staff of Marvel Mfg. Co. are getting set for vacation time. The firm will close on July 3 and reopen for business on Monday, July 27 . . . A new kiddie ride is on display at the World Wide Dist. showrooms. It's called "Palomino" and **Howie Freer** says it's an extremely well constructed piece of equipment. **Fred Skor** had tons of praise for Williams' "Bonanza", to which operators have been receptive.

Happy to report that Bally ad manager **Herb Jones** returned to his office last week after a stay in the hospital. He was knee deep in accumulated paperwork when we called, but he's feeling just fine and is pleased to be back at work . . . Export is way up at National Coin Machine Exchange. Domestically, the local trucking strike-lock-out (which, by the way, is in its 11th week) has certainly put a damper on things. **Mort Levinson** says the distrib's enjoying plenty of action with Gottlieb's "Baseball", the Wurlitzer "Statesman", etc., but meeting customers' demands is not so easy, under present circumstances.

Production schedules at Chicago Dynamic Industries are currently centering on "Speedway" and "Esquire"! The newly released 6-player puck bowler is enjoying wide acceptance, according to **Mort Secore**, and is fast becoming a strong item . . . MOA recently issued the first supply of promotion stickers and is hopeful they will be used by everyone in the trade on all correspondence. This is an excellent way to promote Expo '70. Remember, the stickers are free for the asking so if you need more please contact the local MOA office.

On the singles scene, **Joe Ceddia** of Lormar lists the following new releases as active with local operators: "No Arms Can Ever Hold You" by **Bobby Vinton** (Epic), "I Just Can't Help Believin'" by **B. J. Thomas** (Scepter) and "Our Song (La Paloma)" by **Engelbert Humperdinck** (Parrot).

**IF you are reading  
someone else's copy of  
Cash Box  
why not mail this coupon  
today!**

**CASH BOX  
1780 BROADWAY  
NEW YORK, N. Y. 10019**

Enclosed find my check.

- \$30 for a full year (52 weeks) subscription (United States, Canada, Mexico)
- \$50 for a full year (Airmail United States, Canada, Mexico)
- \$60 for a full year (Airmail other countries)
- \$40 for a full year (Steamer mail other countries)

(Check One)

I AM A  
DEALER . . . . .  
ONE STOP . . . . .  
DISTRIB . . . . .  
RACK JOBBER . . . . .  
PUBLISHER . . . . .  
RECORD CO . . . . .  
DISK JOCKEY . . . . .  
COIN FIRM . . . . .  
OTHER . . . . .

**NAME** . . . . .

**FIRM** . . . . .

**ADDRESS** . . . . .

**CITY** . . . . . **STATE** . . . . . **ZIP #** . . . . .

Be Sure To Check Business Classification Above!

# coin machine INVENTORY LIST used equipment

A Compilation of

Phonographs and Amusement  
Machines Actively Traded On  
Used Coin Machine Markets

## MUSIC MACHINES

### ROCK-OLA

1485 Tempo II 200 sel '60  
1488 Regis 120 sel '61  
1495 Regis 200 sel '61  
1493 Princess 100 sel '62  
1496 Empress 120 sel '62  
1497 Empress 200 sel '62  
404 Capri I 120 sel '63  
408 Rhapsody I 160 sel '63  
414 Capri II 100 sel '64  
418-SA Rhapsody II 160 sel '64  
424 Princess Royal 100 sel '64  
425 Grand Prix 160 sel '64  
429 Starlet 100 sel '65  
426 Grand Prix II 160 sel '65  
431 Coronado 100 sel '66  
432 GP/160 160 sel '66  
433 GP/Imperial 160 sel '66  
435 Princess Deluxe 100 sel '67  
436 Centura 100 sel '67  
437 Ultra 160 sel '67

### ROWE-AMI

K-120 120 sel '60  
K-200 200 sel '60  
Lyric 100 sel '60  
Continental 200 sel '60  
Continental II 100 sel '61  
Continental II 200 sel '61  
L-200 100-160 sel '63  
M-200 Tropicana 200 sel '64  
N-200 Diplomat 200 sel '65  
O-200 Bandstand 200 sel '66  
MM-1 100, 160, 200 sel '67  
Kadet 100 100 sel '67  
M-2 200 sel '68

### SEEBURG

Q-100 100 sel '60  
Q-160 160 sel '60  
AY-100 100 sel '61  
AY-160 160 sel '61  
DS-100 100 sel '62  
DS-160 160 sel '62  
LPC-1 160 sel '63  
LPC-480 160 sel '64  
Electra 160 sel '65  
Mustang 100 sel '65  
Stereo Showcase 160 sel '66  
Phono Jet 100 sel '67  
Spectra 200 sel '67

### WURLITZER

2400 200 sel '60  
2404 104 sel '60  
2410 100 sel '60  
2500 200 sel '61  
2504 104 sel '61  
2510 100 sel '61  
2600 200 sel '62  
2610 100 sel '62  
2700 200 sel '63  
2710 100 sel '63  
2800 200 sel '64  
2810 100 sel '64  
2900 200 sel '64  
3000 200 sel '65  
3100 200 sel '66  
3200 200 sel '67

## PINGAMES

### BALLY

Beauty Contest (1/60)  
Laguna Beach (3/60)  
Queens (3/60)  
Roller Derby (3/60)  
Barrel-O-Fun (9/60)  
Touchdown (11/60)  
Circus Queen (2/61)  
Lite A-Line (2/61)  
Barrel-O-Fun (4/61)  
Acapulco (5/61)  
Flying Circus 2P (6/61)  
Can Can (10/61)  
Barrel O-Fun (11/61)  
Lido (2/62)  
Golden Gate (6/62)  
Shoot-A-Line (6/62)  
Funspot '62 (11/62)  
Silver Sails (11/62)  
Twist (11/62)  
Moonshot (3/63)  
Cue-Tease 2P (7/63)  
3-In-Line 4P (8/63)  
Hootenany 1P (11/63)  
Star Jet (12/63)  
Monte Carlo 1P (2/64)  
Ship Mates 4P (2/64)  
Bongo 2P (3/64)  
Sky Diver 1P (4/64)  
Mad World 2P (5/64)  
Grand Tour 1P (7/64)  
Happy Tour 1P (7/64)  
2-In-Line 2P (8/64)  
Harvest 1P (10/64)  
Hay Ride 1P (10/64)  
Bus Stop 2P (1/65)  
Bullfight 1P (1/65)  
Sheba 2P (3/65)  
Six Sticks 6P (3/65)  
Band Wagon 4P (5/65)  
Magic Circle 1P (6/65)  
50/50 2P (8/65)  
Aces High 4P (9/65)  
Big Chief 4P (10/65)  
Discotek 2P (10/65)  
Trio 1P (11/65)  
Blue Ribbon 4P (1/66)  
Fun Cruise 1P (2/66)  
Wild Wheels 2P (3/66)

Campus Queen 4P (8/66)  
Capersville 4P (2/67)  
Rocket III 1P (6/67)  
Wiggler 4P (9/67)  
Surfers 1P (1/68)  
Dogies 4P (3/68)  
Dixieland 1P (5/68)  
Safari 2P (7/68)  
Rock Makers 4P (10/68)  
MiniZag 1P (11/68)

### CHICAGO COIN

Sun Valley (8/63)  
Firecracker 2P (12/63)  
Bronco 2P (5/64)  
Royal Flash 2P (8/64)  
Big League Baseball 2P (4/65)  
Par Golf (9/65)  
Hula Hula 2P (5/66)  
Kicker 1P (8/66)  
Festival 4P (1/67)  
Beatniks 2P (2/67)  
Twinky 2P (9/67)  
Gun Smoke 2P (6/68)  
Playtime 2P (9/68)  
Stage Coach 4P (8/68)

### GOTTIEB

Seven Seas 2P (1/60)  
World Beauties 1P (2/60)  
Spot-A-Card 1P (3/60)  
Lite-A-Card 2P (3/60)  
Texas 4P (4/60)  
Captain Kidd 2P (7/60)  
Melody Lane 2P (9/60)  
Kewpie Doll 1P (10/60)  
Flipper 1P (11/60)  
Merry-Go-Round 2P (12/60)  
Foto Finish 1P (1/61)  
Oklahoma 4P (2/61)  
Showboat 1P (4/61)  
Flipper Parade (5/61)  
Flying Circus (6/61)  
Big Casino 1P (7/61)  
Lancer 2P (8/61)  
Corral (9/61)  
Aloha 2P (11/61)  
Flipper Fair 1P (11/61)  
Egg Head 1P (12/61)  
Liberty Belle 4P (3/62)  
Flipper Clown (4/62)  
Fashion Show 2P (6/62)  
Cover Girl 1P (7/62)  
Preview 2P (8/62)  
Olympics 1P (9/62)  
Flipper Cowboy 1P (10/62)  
Sunset 2P (11/62)  
Rock-A-Ball 1P (12/62)  
Gaucha 4P (1/63)  
Slick Chick 1P (4/63)  
Swing Along 2P (7/63)  
Sweet Hearts 1P (9/63)  
Flying Chariots 2P (10/63)  
Gigi 1P (12/63)  
Big Top 1P (1/64)  
World Fair 1P (5/64)  
Bonanza 2P (6/64)  
Bowling Queen 1P (8/64)  
Majorettes 1P (8/64)  
Sea Shore 2P (9/64)  
North Star 1P (10/64)  
Happy Clown 4P (11/64)  
Sky Line 1P (1/65)  
Thoro Bred 2P (2/65)  
Kings & Queens 1P (3/65)  
Hi Dolly 2P (5/65)  
Cow-Poke 1P (5/65)  
Buckaroo 1P (6/65)  
Dodge City 4P (7/65)  
Bank-A-Ball 1P (9/65)  
Paradise 2P (11/65)  
Flipper Pool 1P (11/65)  
Ice Review 1P (12/65)  
King Of Diamonds 1P (1/66)  
Masquerade 4P (2/66)  
Central Park 1P (4/66)  
Mayfair 2P (6/66)  
Dancing Lady 4P (11/66)  
Super Score 2P (3/67)  
Sing-A-Long 1P (9/67)  
Surf Side 2P (12/67)  
Royal Guard 1P (1/68)  
Spin Wheel 4P (3/68)  
Funland 1P (5/68)  
Paul Bunyan 2P (8/68)  
Domino 1P (10/68)  
Four Seasons 4P (12/68)

### KEENEY

Old Plantation (2/61)  
Rainbow (6/62)  
Go-Cart 1P (5/63)  
Poker Face 2P (9/63)

### MIDWAY

Rodeo 2P (10/64)

### WILLIAMS

Black Jack 1P (1/60)  
Golden Gloves 1P (1/60)  
Twenty-One 1P (2/60)  
Nags 1P (3/60)  
Serenade 2P (5/60)  
Darts 1P (6/60)  
Music Man 4P (8/60)  
Jungle 1P (9/60)  
Viking 2P (10/61)  
Space Ship 2P (12/61)  
Coquette (4/62)  
Trade Winds (6/62)  
Valiant 2P (8/62)  
King Pin (9/62)  
Vagabond (10/62)

Mardi Gras 4P (11/62)  
Four Roses 1P (12/62)  
Tom Tom 2P (1/63)  
Big Deal 1P (2/63)  
Jumpin' Jacks 2P (4/63)  
Skill Pool 1P (6/63)  
El Toro 2P (8/63)  
Big Daddy 1P (9/63)  
Merry Widow 4P (10/63)  
Beat The Clock (12/63)  
Oh Boy 2P (2/64)  
Soccer 1P (3/64)  
San Francisco 2P (5/64)  
Palooka 1P (5/64)  
Heat Wave 1P (7/64)  
Riverboat 1P (9/64)  
Whoopee 4P (10/64)  
Zig-Zag 1P (12/64)  
Wing Ding 1P (12/64)  
Alpine Club 1P (3/65)  
Eager Beaver 2P (5/65)  
Moulin Rough 1P (6/65)  
Lucky Strike 1P (8/65)  
Big Chief 4P (10/65)  
Teachers Pet 1P (12/65)  
Bowl-A-Strike 1P (12/65)  
Full House 1P (3/66)  
A-Go-Go 4P (5/66)  
Top Hand 1P (5/66)  
Magic City (1/67)  
Magic Town 1P (2/67)  
Jolly Roger 4P (12/67)  
Ding Dong 1P (2/68)  
Lady Luck 2P (4/68)  
Student Prince 4P (7/68)  
Doozie 1P (9/68)  
Pit Stop 2P (11/68)

## SHUFFLES

### BALLY

Official Jumbo (9/60)  
Jumbo Deluxe (9/60)  
Super Shuffle (12/61)  
Big 7 Shuffle (9/62)  
All The Way (10/65)

### CHICAGO COIN

6-Game Shuffle (6/60)  
Triple Gold Pin Pro (2/61)  
Starlite (5/62)  
Citation (10/62)  
Strike Ball (5/63)  
Spotlite (11/63)  
DeVille (8/64)  
Triumph (1/65)  
Top Brass Shuffle (4/65)  
Gold Star Shuffle (7/65)  
Belaire Puck Bowler  
Medalist (4/66)  
Imperial (9/66)  
Riviera (6/67)  
Sky Line (1/68)  
Melody Lane (4/68)

### UNITED

Big Bonus (2/60)  
Sunny (5/60)  
Sure Fire (10/60)  
Line-Up (1/61)  
5-Way (5/61)  
Avalon (4/62)  
Silver (6/62)  
Shuffle Basketball (6/62)  
Action (7/62)  
Embassy (9/62)  
Circus Roll-down (9/62)  
Lancer (11/62)  
Sparky (12/62)  
Caravelle (2/63)  
Crest (4/63)  
Rumpus Tarquette (5/63)  
Astro (6/63)  
Ultra (8/63)  
Sippy (11/63)  
Jill-Jill (11/63)  
Bank Pool (11/63)  
Topper (2/64)  
Tempest (2/64)  
Pacer (4/64)  
Tiger (7/64)  
Orbit (8/64)  
Mombo (12/64)  
Cheetah (3/65)  
Pyramid (6/65)  
Corral (10/65)  
Tango (2/66)  
Blazer (6/66)  
Encore (9/66)  
Altair (3/67)  
Orion (11/67)  
Alpha (3/68)  
Pegasus (8/68)

## BOWLERS

### BALLY

Super 8 (4/63)  
Deluxe Bally Bowler (1/64)  
1965 Bally Bowler (65)  
1966 Bally Bowler (4/66)

### CHICAGO COIN

Duke (8/60)  
Duchess (8/60)  
Princess (4/61)  
Gold Crown (3/62)  
Royal Crown (8/62)  
Grand Prize (3/63)  
Official Spare Lite (9/63)  
Cadillac (1/64)

Majestic (8/64)  
Tournament (12/64)  
Super Sonic (3/65)  
Preview (9/65)  
Corvette (2/66)  
Flair (9/66)  
Vegas (3/67)  
Fleetwood (9/67)

### UNITED

Falcon (4/60)  
Savoy (5/60)  
Bowl-A-Rama (9/60)  
Tip Top (10/60)  
Dixie (1/61)  
Cameo 5 Star (5/61)  
Classic (6/61)  
Alamo (4/62)  
Sahara (7/62)  
Tropic (9/62)  
Lucky (11/62)  
Cypress (12/62)  
Sabre (2/63)  
Regal (4/63)  
Fury (8/63)  
Futura (12/63)  
Tornado (3/64)  
Thunder (6/64)  
Polaris (8/64)  
Galleon (3/65)  
Bowl-A-Rama (7/65)  
Amazon (3/66)  
Aztec (9/66)  
Coronado (6/67)

## BASEBALL

Bally Ball Park (4/60)  
CC Big Hit (10/62)  
CC All Star Baseball (1/63)  
CC All Stars Baseball (2/68)  
Kaye Batting Practice (7/68)  
Midway Deluxe Baseball (5/62)  
Midway Slugger (3/63)  
Midway Top Hit (3/64)  
Midway Little League (66)  
Midway Fun Ball (1/67)  
United Bonus Baseball (3/62)  
Wms Official Baseball (4/60)  
Wms Deluxe Batting Champ (5/61)  
Wms Extra Inning (5/62)  
Wms World Series (5/62)  
Wms Major League (3/63)  
Wms Grand Slam (2/64)  
Wms Double Play (4/65)  
Wms Ball Park (2/68)

## GUNS

Bally Derby Gun (2/60)  
Bally Sharpshooter (2/61)  
CC Ace Machine Gun (11/67)  
CC Ray Gun (10/60)  
CC Long Range Rifle Gallery (1/62)  
CC Ace Machine Gun (1/68)  
CC Riot Gun (6/63)  
CC Carnival (5/68)  
CC Champion Rifle Range (1/64)  
Keeney Two Gun Fun (3/62)  
Midway Shooting Gallery (2/60)  
Midway Target Gallery (7/62)  
Midway Monster Gun (67)  
Midway Carnival Tgt. Gtry (2/63)  
Midway Rifle Range (6/63)  
Midway Trophy Gun (6/64)  
Midway Captain Kid Rifle (9/66)  
Williams Aqua Gun (3/68)  
Williams Arctic Gun (67)

## ARCADE

Amer Shuffle Situation (5/61)  
Bally Skill Score (6/60)  
Bally Skill Derby (10/60)  
Bally Table Hockey (2/63)  
Bally Spinner (2/63)  
Bally Bank Ball (1/63)  
Bally Fun Phone (3/63)  
Bally World Cup (1/68)  
CC Pony Express (4/60)  
CC Wild West (5/61)  
CC Pro Basketball (6/61)  
CC All American Basketball (1/68)  
CC Popup (10/64)  
Midway Bazooka (10/60)  
Midway Flying Turns (9/64)  
Midway Raceway (10/63)  
Midway Winner (12/63)  
Midway Mystery Score (8/65)  
Southland Speedway (6/63)  
Southland Time Trials (9/63)  
Williams Road Racer (5/62)  
Williams Hay Burner II (9/68)  
Williams Voice-O-Graph (62)  
Williams Mini Golf (10/64)  
Williams Hollywood Driving Range (4/65)

# CLASSIFIED ADVERTISING SECTION

## COIN MACHINES WANTED

WANTED TO BUY OUT SELLING STOCKS ONE OR two years old Jennings slot machines, Wurlitzer juke boxes and Pinball games two or four players, make an offer to AUTOMATTJANST N STORGATAN 19 BJUV, SWEDEN.

WANTED: Midway Red Balls, Joker Balls and Joker's Wild. Any Condition. Contact AMERICAN MUSIC CO., 219 First Ave. South Great Falls, Montana. (406) 452-7301.

WANT — Pool Tables, Personal music equipment, Scopitone film, 69 - 68 model Phonographs new and used, Phono Vue attachments, Distribution of allied products. Write stating make, model, condition and best cash price. ST. THOMAS COIN SALES, 669 TALBOT ST., ST. THOMAS, ONTARIO, CANADA. AREA 519-631-9550.

OLD BALL GUM OR PEANUT MACHINES, table model games of skill or chance from 1950 & earlier, early arcade machines, slots, any quantity or condition. SACKIN, 318 E. 70 St., N.Y.C., N.Y. 10021 — 212-628-0413.

WE ARE ALWAYS INTERESTED IN USED AND BRAND new phonographs, pinballs, bingos, guns, arcade, kiddie rides, slot machines, etc., all makes, all models. QUOTE FOB SEA VESSEL TO HOLLAND BELGIE EUROPE, SPRL., 276 AVENUE LOUISE, BRUSSELS.

WANTED: SEEBURG CONSOLLETES AND D.S.'s. HENDON AUTOMATICS LIMITED. 50, Crewys Road, London N.W. 2, England.

## COIN MACHINES FOR SALE

FOR SALE: Model 14 Auto Photo, EXCELLENT condition. Call or Write. New in original cartons. Hollywood Driving Range. 15 ball golf fame. Closeout \$295 ea. CLEVELAND COIN INTERNATIONAL, 2025 Prospect Avenue, Cleveland, Ohio. Phone (216) 861-6715.

FOR SALE: Jukeboxes, pinballs, arcade, guns, baseballs, Kiddie rides, European football machines. For Export: Uprights, bingos, consoles, slots and punchboards. Contact: MYRON SUGERMAN INTERNATIONAL, 140 Central Ave., Hillside, N.J. (201) 923-6430.

FOR SALE/EXPORT — Bally slots \$295 & up; Mills Open Front, like new, \$285; Mills HiTop \$125; Jennings Galaxy \$285; Uprights: Clover Belle \$300; Keeney Super Bonus \$300; Draw Belles \$75. Large stock Bally Bingos. Bally parts for export. BALLY DISTRIBUTING COMPANY, 390 East 6th St., P. O. Box 7457, Reno, Nevada 89502. (702) 323-6157.

ALL TYPES OF COIN-OPERATED ARCADE EQUIPMENT for sale — guns, Helicopters, pinballs, etc.; Auto-Photo machines. Write for equipment list and prices. ROCK CITY DISTRIBUTING CO., INC., 615 Murfreesboro Road, Nashville, Tenn. 37210.

FOR SALE: Keeney Black Dragons, Wild Arrow, Twin Dragons, Flaming Arrows and Mountain Climbers. Also Bally Slot Machines, Triple Bells, Draw Bell and Buckley Track Odds. Want Old Slots. SASKATCHEWAN COIN MACHINE CO., 1025-104th St., North Battleford, Saskatchewan, Canada. Phone 445-2989 — Area Code 306.

FOR SALE: MANNEQUINS WITH SCREWS FOR FOOTBALL and soccer games \$1.75 each — send check with order. Budge Wright's WESTERN DISTRIBUTORS, 1226 SW 16th, Portland, Oregon. 228-7565.

FOR EXPORT: BRAND NEW MADE IN JAPAN JUKE-boxes, Kiddie Rides, Arcade, Guns, INDY-500, SUBROC, now obtainable DISTRIBUTORSHIP, also various used Games and Phonographs, Contact: KAY A. CHIBA, Port P.O. Box 111, Yokohama, Japan.

FOR SALE TO PENNSYLVANIA OPERATIONS ONLY: Counter Disks for Barrel Film. 61, 62, 63 and shoot-a-line. AMERICAN MUSIC MACHINE, 57 South Penn. York, Pa. Phone 843-6201.

FOR SALE: Two Panoram peep show machines with optional 25¢ or 50¢ coin chute. Continuous reel that holds 1,000 ft. of 16mm film. Operated with a time unit. PHIL GOULO, 224 Market Street, Newark, N.J. Tel: 201 — Market 4-3297

## CLASSIFIED AD RATE 20 CENTS PER WORD

Count every word including all words in firm name. Numbers in address count as one word. Minimum ad accepted \$5.00. CASH OR CHECK MUST ACCOMPANY ALL ORDERS FOR CLASSIFIED ADVERTISING. If cash or check is NOT enclosed with order your classified ad will be held for following issue pending receipt of your check or cash.

NOTICE — \$82 Classified Advertisers (Outside USA add \$52 to your present subscription price). You are entitled to a classified ad of 40 words in each week's issue for a period of One Full Year, 52 consecutive weeks. You are allowed to change your Classified Ad each week if you so desire. All words over 40 will be billed at the rate of 20¢ per word. Please count words carefully. Be sure your Classified Ad is sent to reach New York publication office by Wednesday, 12 noon, of preceding week to appear in the following week's issue.

### Classified Ads Close WEDNESDAY

Send all copy to: CASH BOX, 1780 Broadway, N.Y., N.Y. 10019

BINGOS AND 6 CARD GAMES AVAILABLE INCLUDING Silver Sails and Golden Gates. These games are shopped! Call WASSICK NOVELTY at (304) 292-3791 Morgantown, West Virginia.

FOR SALE — NEW IN CASE: 300 Jennings Double 10¢ Vendors. Retail at \$59.95 — 25.00 each. All types used Novelties. Call or Write: E. L. Simmons, DANVILLE AMUSEMENT CO., INC., 620 Westover Drive, Danville, Va. Phone 792-5044.

POOL TABLES—Large selection of all makes and models available. Completely reconditioned or in "as is" condition for immediate shipment at very attractive prices. Also large selections of pin games, shuffles, guns and music—Phone or write: EASTERN NOVELTY DISTRIBUTORS, INC., 3726 Tonnele Avenue, North Bergen, New Jersey 07047—(201) 864-2424.

FOR SALE: 2 Player Preview, Gottlieb \$125 ea.; 1 Player Ice Revue, Gottlieb \$175 ea.; 1 Player Bank A Ball, Gottlieb \$170 ea.; 4 Player Happy Clown, Gottlieb \$175 ea.; 4 Player Dodge City, Gottlieb \$295 ea.; 1 Player Full House, Williams \$179.50 ea. All equipment A-1 condition. Send 1/3 deposit. CENTRAL MUSIC CO., P.O. Box 284, Killeen, Texas 76541.

FOR SALE: RECONDITIONED BARGAINS: Bally Wild Wheels (2 pl) \$195; World Cup (2 pl) \$245; Gottlieb Sweet Hearts (1 pl) \$95; Central Park (1 pl) \$165; Wurlitzer 2150 (200 Sel) \$95; 2304 \$95; 3010-1 (100 Sel) \$495; Rock-Ola 414 (100 Sel) \$345. MICKEY ANOERSON AMUSEMENT CO., 314 E. 11th St., Erie, Pa. 16503. Phone 452-3207.

FOR SALE: Bingos, Orient, Zodiac, Bahama Beach, Follies Bergere, Beauty Beach, Sho Gal, All others. Late 4 & 2 Player Flippers. AMI J-200 \$215. K-200 \$225; JAL \$200. JEL \$225. Photomatic & Arcade Machines: Buckley Track Odds — CROSSE-OUNHAM & CO., Tel. 504—367-4365. 225 Wright Ave., Gretna, La. 70053.

FOR EXPORT: Late games, Phonos, Vending. Write for our latest listing. ADVANCE DISTRIBUTING COMPANY, 2820 North Grand Blvd., St. Louis, Missouri 63107 — (314) 652-1600.

FOR SALE: Large selection used Pin Games to choose from, write for price list. BIRD MUSIC DISTRIBUTORS, INC., Manhattan, Kansas, Box B, or Phone: 778-5229.

FOR SALE: WILLIAMS Spooks Gun \$425; MIDWAY Flying Saucer \$350; MIDWAY Space Gun \$315; MIDWAY Monster Gun \$225; MIDWAY 1 Million B.C. Gun \$395; Tusco Horse \$300; BALLY Champion Horse \$350. UNITED DISTRIBUTORS, INC., 902 W. Second, Wichita, Kansas 67203.

FOR SALE: 12 Panorams Peep Shows RCA 16mm with timers. Mint condition. Also film B&W used \$8 Color \$25. Approx. 400 ft. Money makers. R. RICHTER, 1063 Market St., San Francisco, Calif. 7, 94103.

NEVADA FRUIT (SLOT) MACHINES PRESENTS: The Raven Electronics Solid-State line of Fruit (slot) Machines, Kenos and Mini-Bingos. 150 Mills Front-Opening stands included as NEW \$200.00 Ea. 310 Bally Bingos, all models. Write or Call anytime — P.O. Box 5734, Reno, Nevada 89503. (702) 329-3932.

FOR SALE: CLOSE-OUT — READY FOR LOCATION. GOTT: Royal Guard, Crosstown, Ice Revue, North Star, Buckeroo, (2 pl.) Paradise, Flying Circus, (4 pl.) Dancing Lady, WMS: Apollo, Full House, Moulin Rouge, Alpine Club, Riverboat, Beat the Clock. SEEBURG 3W1 D Wallboxes. D & L COIN MACHINE CO., 414 Kelker Street, Harrisburg, Pa. 17105. Phone: (717) 234-4731, 234-2235.

BINGOS FOR EXPORT: BIG WHEELS, LAGUNA BEACHES, Can Cans, Golden Gates, Circus Queens, Bikinis, Bountys, and Border Beauty. All types of pin balls available. D & P MUSIC, 27 E. Philadelphia Street, York, Pa. Phone (717) 848-1846.

ALL TYPES OF COIN-OPERATED EQUIPMENT. AOO-A-Balls, shuffles, guns, computers, etc. All types of phonographs; large selection on hand. Vending machines, from cigarette to candy to can drink, etc. . . . all kinds, shopped to perfection. Write or call FLOW-ER CITY OIST. CO., 389 Webster Ave., Rochester, N.Y. 14609. Tel. (716) 654-8020 and ask for JOE GRILLO.

50 ROWE 2700 CIGARETTES COMPLETE—OFF LOCATION. As-is condition. Make offer. THE MACKIE COMPANY, Central Pennsylvania, 1201 South 20th Street, Harrisburg, Pennsylvania 17104. 717—238-1768. Manny Silvia.

FOR SALE: PANORAMS NEW MARK OUAL 8 — Write or call URBAN INDUSTRIES, INC., P.O. Box 31, Louisville, Kentucky 40201. (502) 969-3227.

FOR SALE: SHUFFLE ALLEYS, UNITED: ALPHA \$550; Gamma \$750; PEGASUS \$575; Delta \$675; Seeburg Electra \$550. MOHAWK SKILL GAMES COMPANY, Ogden Whitebeck, Prop., 67 Swaggertown Road, Scotia, New York 12302.

FOR SALE: REBUILT PHONOGRAPHS AND GAMES: Seeburg LPC1's \$495; LPC480's \$575; Electras \$650; Fleetwood \$675; Showcase \$795; Lady Luck \$450; Hayburner II \$425; Suspense \$525; Paul Bunyan \$395; Domino \$350. OPERATOR SALES, INC., 4122 Washington Avenue, New Orleans, La. 70125. Phone 822-2370 (504).

ALL TYPES COIN OPER AMUSE MACHINES, NEW AND reconditioned. Ready for location. Write for latest listings. Full line and parts and supplies. MUNVES CORP., Dept. BC — 577 10th Avenue, New York, N.Y. 10036. Phone 212—279-6677.

FOR SALE: LONDONS, VENICE, ORIENTS, ZOOIACS, Sky Rides, Big Wheels, Bountys, Bahamas Beaches, Follies Bergeres, Beauty Beach, Border Beautys, Silver Sails, Golden Gates and other bingos. NEW ORLEANS NOVELTY COMPANY, 1055 Oryades Street, New Orleans, Louisiana 70113. Tel. (504) 529-7321. CABLE: NONOVCO

FOR SALE/EXPORT: NEW BACKGLASSES FOR COUNTRY Fairs, Sea Islands, Roller Derbys, Can Cans, Bikinis, Lite Lines, Cypress Gardens, Ballerinas, Blæk Dragons. Numerous used BACKGLASSES. Complete bingo games include County Fairs, Lagunas, Lidos, Circus Queens. MUSIC VEND OISTRIBUTING, 100 Elliott West, Seattle. Phone 206—284-7740.

FOR SALE: TOPGRAOE GERMAN CORKBALLS \$3.75 set. Manikins \$1.75 each; also soccer parts available. Send check with order. Budge Wright's WESTERN DISTRIBUTORS, 1226 SW 16th, Portland, Oregon 228-7565.

FOR EXPORT: BRAND NEW MADE IN JAPAN JUKE-boxes, Kiddie Rides, Arcade, Guns, INDY-500, SUBROC, now obtainable DISTRIBUTORSHIP, also WANTED TO BUY new and used table/couner games, Bally SKILL PARADES, German ROTAMINT-Bingo, Bingo Royal. CONTACT: KAY A. CHIBA, Port P.O. Box 111, Yokohama, Japan.

FOR SALE: Skippers \$485; Gay 90's \$570; Smart Sets \$465; Phantom Guns \$525; King Tuts \$350; NUTTING ASSOC.—Computer Quizzes \$450; Sports Worlds \$465; Astro Computers — WRITE: C.C.—Safari Guns \$495; C.C.—Super Circus Guns — WRITE: MIOWAY—White Lightning \$490; MIDWAY—Flying Saucers \$410; Mini Soccer \$125; SEGA—Duck Hunts \$475; SEGA—Basketballs \$325; SEGA—Missiles \$675. Also large stock of bingos. NEW ORLEANS NOVELTY COMPANY, 1055 Dryades Street, New Orleans, Louisiana 70113, Tel (504) 529-7321 CABLE: NONOVCO

## HUMOR

DEEJAYS! 11,000 hilarious classified one-liners, \$10. Or send \$15 for above plus 7,500 additional "Clever Remarks!" Unconditionally guaranteed. You must be delighted or we'll refund your money. Comedy catalog free on request. Edmund Orrin, Boyer Road, Mariposa, Calif. 95338

DEEJAY GAGS GALORE! One liners, artist quips, record intro's, Fall-Winter issue JUST OUT. We write for deejays only. Topical, clean, Yocks for Jocks. "DEEJAY DIGEST" — \$2.00 — GET FREE BACK ISSUE WITH — FIRST ORDER. MORRIS, 7047 Franklin, Hollywood, California 90028

## EMPLOYMENT SERVICE

BINGO MECHANICS WANTED: Legal territory of Nevada, 5 day, 40 hour work week. MUST have past Bingo experience. State age, references, past experience. Send photo if possible. Write or phone: UNITED COIN MACHINE CO., 2621 South Highland, Las Vegas, Nevada. Phone (702) 735-5000.

MECHANICS WANTED FOR MUSIC AND PINS. SALARY commensurate with ability. Time and half for over forty hour week. Liberal fringe benefits plus vehicle. Contact AMUSE-A-MAT CORP., 123 E. Luzerne St., Philadelphia, Pa. 19124. Telephone (215) 570-5700.

EXPERIENCED MECHANICS NEEDED FOR GAMES, phonos and pins. Excellent salary — paid vacation and insurance. Call collect, DIXIE DISTRIBUTING CO., AC 713-Jackson 2-7156, Houston, 77027 Texas Ask for Mr. Webber or Mr. Binks.

## RECORDS-MUSIC

WANT: RECORDS, 45'S AND LP'S SURPLUS RETURNS, overstock, cut-outs, etc. Call or write: HARRY WARRINER at: KNICKERBOCKER MUSIC CO., 453 McLean Ave., Yonkers, New York 10705. GR 6-7778.

45 RPM RECORDS, NEW. NO QUANTITY TOO LARGE or small. Highest prices paid. Write stating quantity on hand. TONY GALGANO DIST. CO. 4135 W. ARMITAGE, CHICAGO 39, ILL. (Tel. Dickens 2-7060)

USED 45 RPM RECORDS. ALL TYPES AS THEY RUN, right off the route. No sorting or picking. We pay freight from anywhere in U.S.A. Standing order available for regular shippers. JALEN AMUSEMENT CO., 1215 S. HOWARD STREET — BALTIMORE, MARYLAND 21230.

WANTED: EXPERIENCED JUKE BOX AND GAME MECHANIC. Good working conditions. Paid vacations, sick leave, time and one half for overtime to reliable man. Call Mr. Anderson COLLECT, PERSON TO PERSON. Telephone 237-1563. COIN MUSIC INC., 710 R St., Fresno, California.

FREE CIRCULAR — HARD TO FIND NEW COUNTRY record albums and 8 track tape cartridges. Fiddle tunes, waltzes, blue grass, etc. Such artists as Mac Wiseman, Hylo Brown, the legendary J.E. Mainer, others. UNCLE JIM O'NEAL, Box AC, Arcadia, California 91006.

LEADING TAPE WHOLESALER WILL SELL HIGHEST chart tapes at lowest prices. Send for current list. CANOY STRIPE RECOROS, 17 Alabama Ave., Island Park, N.Y. 11558.

OFFERING EIGHT CENTS EACH PLUS FREIGHT FOR forty-fives, not over six months old, as they come off your routes. Ship freight collect to ESDAY, 12444 Chapman, Garden Grove, Calif. — Guaranteed count payment by return mail.

WE SELL 45s, LPs TO RECORD DEALERS, COLLECTORS, one-stop, foreign — Send free catalogue. \$7.00 per hundred, \$63.00 per thousand. We need 45s, lps — Disk Jockey copies, surplus, overstock, cutouts. CAPE INTERNATIONAL, Box #74, Brooklyn, N. Y. 11234. Phone: (212) 253-5916—5917.

WILL SWAP CHART OLOIBS BUT GOODIES FOR MONO and Stereo Closeout LP's. Contact Michael Adler at SCORPIO MUSIC DISTRIBUTORS INC., 6720 N. Broad Street, Philadelphia, Pa. 19126 (215) 549-5772.

LOOK! RARE OLDIES. ROCK AND R & B ALBUMS. WE have the ones you can't get in the stores. Call Dave, 212—243-1548 or Bob, 212—253-3712. Send want list to C. B. Fisch, A & G RECORDS, 135 Ocean Pkwy., Brooklyn, N. Y. 11218.

WANTED: 8-TRACK TAPE CARTRIDGES, AND LP's. MUST be priced right—smaller quantities preferred. STEINER — 45 Bergen St., Brooklyn, N.Y. 11201.

## COIN MACHINE SERVICES

ACE LOCKS KEYED ALIKE. SENO LOCKS AND THE key you want them mastered to \$1.00 each less 10% lots of 50 or more. DANDEL LOCK SERVICE, 61 ROCKAWAY AVENUE, VALLEY STREAM, N.Y. 11580. TEL: 516-VA 5-6216. OUR 35th YEAR IN VENDING.

SPEED UP YOUR COIN COLLECTIONS — New portable coin sorting, counting and packing machine, combined as one unit — hand operated — portable — weighs 18 pounds — with automatic stops and tubes for different sizes. Apply SEIFERT MACHINERY CO., Box 3421, Philadelphia, Pa. 19122.

FLOATING FUN BALLOON VENDING MACHINE. DOES NOT have to be attended. Space Age Memory Control Panel, 25¢ vend. Literature at your request. Dukane Ski n Skore and Grand Prix parts available. NOVEMBER CORPORATION, 1351 W. Grand Ave., Chicago, Illinois 60622. (312) 733-2988.

APRONS: FOR VENOORS—COIN CHANGERS. YOU have it we will make it. Uniforms, work clothes and emblems. E & M SUPPLY CO., 2090 Pacific Blvd., Atlantic Beach, N. Y. 11509.

STAMP-A-SPOT ON YOUR POOL TABLE. ELIMINATES curled spots, high spots, replacements. Stamp it on and forget it for the life of the cloth. Send your order and check for \$6.95 to-day to: P. O. BOX 69, Inwood N. Y. 11696.

## CLASSIFIED POWER!

### CLASSIFIED AD RATE 20 CENTS PER WORD

Got machines to sell? Is there something you're looking to buy? Maybe you'd like to move some used 45's or need a route mechanic? For every coin machine need, use the Cash Box Classified.

Type Or Print Your Ad Message Here:

### Classified Ads Close WEDNESDAY

Send all copy to: CASH BOX, 1780 Broadway, New York, N.Y. 10019

Here's where he's been in the last six months:

Staller Hilton — San Francisco

The Shoreham Hotel — Chicago

The Jung Hotel — New Orleans

Six appearances on the Arthur Godfrey Show — CBS Radio

Ten appearances on Kraft Music Hall, NBC-TV

Four appearances on Mike Douglas (including co-host last outing)

Two weeks at the Frontier Hotel — Las Vegas, with Wayne Newton

The Sands Hotel — Las Vegas, with Alan King

The Shamrock Hotel — Houston (for 2 weeks, June 4-18)

And here's where he's going:

Doing Tom Sawyer at Starlight Theatre — Kansas City (July 6-19)

As you can see, a lot of people already know about Browning Bryant's clear voice and fresh style. About the only thing he could top his credits with is a spot on The Ed Sullivan Show. Which is coming this fall. And the way we feel, it just can't hurt. Sales, that is.

**Browning Bryant's new single,  
"One Time in a Million" c/w "Tina"**

**47-9825**

**His new album,**

**"One Time in a Million"**

**LSP-4356**



**For a 13-year-old from Pickens, South Carolina,  
he really gets around.**



**Cash Box**



**WORLDWIDE  
DIRECTORY  
1970/1971**





# "THANKS JOCK"

In honor of you honoring us with honorable honors, we hereby have the honor of honoring you. Honest.  
The 1969 Thanks Jock Distinguished Award For Putting Us in Our Place in the 1969 Cosh Box Disc Jockey Poll

This certificate entitles the recipient to all suitable rights and privileges. Whatever they are.  
Void in States where it is taxed. And not very worthwhile in States where it isn't.



**THE FIRST  
ANNUAL  
"THANKS JOCK"  
AWARD.**

(inside)

# YOU DISC JOCKEYS HAVE VOTED RCA RECORDS SO MANY AWARDS IN THE 1969 CASH BOX DISC JOCKEY POLL—

OP—

- #1 Most Programmed Record . . . "Sugar, Sugar." The Archies on the Kirshner label.
- #1 Most Programmed Orchestra . . . Henry Mancini
- #2 Most Promising Up and Coming Orchestra . . . Danny Davis and the Nashville Brass
- #4 Most Programmed Instrumentalist . . . Chet Atkins
- #5 Most Promising Up and Coming Vocal Group . . . The Friends of Distinction
- #7 Most Promising Up and Coming Vocal Group . . . The Guess Who
- #8 Most Programmed Instrumentalist . . . Floyd Cramer

C&W—

- #1 Most Programmed Instrumentalist . . . Chet Atkins
- #1 Most Programmed Vocal Group . . . Porter Wagoner and Dolly Parton
- #1 Most Programmed Band . . . Danny Davis and the Nashville Brass
- #2 Most Programmed Album . . . "The Best of Charley Pride"
- #2 Most Programmed Instrumentalist . . . Floyd Cramer
- #3 Most Programmed Male Vocalist . . . Charley Pride
- #3 Most Programmed Single . . . "All I Have to Offer You (Is Me)," Charley Pride
- #3 Most Programmed Instrumentalist . . . Danny Davis and the Nashville Brass
- #4 Most Programmed Female Vocalist . . . Connie Smith
- #5 Most Programmed Album . . . "Just Plain Charley" Charley Pride
- #5 Most Programmed Female Vocalist . . . Dolly Parton
- #5 Most Programmed Up and Coming Vocal Group . . . The Kimberlys
- #6 Most Programmed Up and Coming Vocal Group . . . Nat Stuckey and Connie Smith
- #7 Most Programmed Single . . . "(I'm So) Afraid of Losing You Again." Charley Pride
- #7 Most Programmed Album . . . "Movin' On" . . . Danny Davis and the Nashville Brass
- #7 Most Programmed Up and Coming Vocal Group . . . The Stonemans
- #7 Most Programmed Female Vocalist . . . Dottie West
- #9 Most Programmed Album . . . "Porter Wayne and Dolly Rebecca," Porter Wagoner and Dolly Parton

## —WE THINK IT'S HIGH TIME WE GAVE YOU AN AWARD.

# WILL THERE BE A SECOND ANNUAL "THANKS JOCK" AWARD?

## COULD BE.

Our award winners of 1969 have already produced a whole bunch of good stuff in 1970.  
Like on this page.

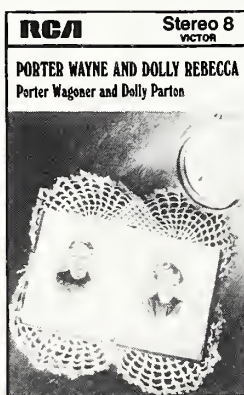

LSP-4305  
P8S-1550  
PK-1550



LSPX-1000  
P8S-1596  
PK-1596



The Archies'  
new single –  
"Sunshine"  
63-1009



LSP-4334  
P8S-1568  
PK-1568



LSP-4331  
P8S-1570  
PK-1570

**RCA** Records  
and Tapes

And if next year you vote them another whole bunch of neat awards, well . . . we're only human.  
One hand washes the other, as they say.



**ANNUAL**  
*World Wide*  
**COIN MACHINE**  
**DIRECTORY**

1970-1971

*28th Anniversary Edition*

*from the desk of . . .*

GEORGE ALBERT

OF



JULY, 1970

Dear Friends:

On January 1, 1970, the coin machine industry, along with its sister industries in the entertainment world, entered the much heralded "leisure 70's". While some members of the jukebox and games trade waited for a bonanza in additional dollars to break around their shoulders, some charged forth to meet it half-way -- by establishing modern fun centers and by exploiting additional locations in virtually untapped areas like schools, shopping malls and the hotel-motel complex. What is the net result after the first six months?

While a great many firms held back any additional investment into the budding leisure explosion, fearing an economic slowdown that might reach into the consumer's change purse, many more wisely sought after a bigger share of the market by spending to improve services and enlarge the route. The latter know this business by its other name -- a depression industry -- a dubious title, but a fact of life. Music and games are "everyman's" opera, his ball park, his race track -- the only place today where he can still enjoy a few minutes of pure entertainment for a quarter.

Recognizing the proud position of the music and games industry on the international scene, and the role of Cash Box as one of the tools utilized by that industry in its drive toward increased prosperity, I am pleased to present our 1970-71 World Wide Directory edition. Its pages of reference material carry the "who, what and where" information to the four corners of this globe -- necessary information to every firm serving the public via the coin chute.

We are proud to be a part of this trade, and on my own behalf, as well as for the entire staff at Cash Box, may I thank you once again for making it possible to serve you.

George Albert

President and Publisher

*George Albert*

# MYRON SUGERMAN INTERNATIONAL SUPPLIES THE WORLD . . .

**Our Agents Are Everywhere  
READY TO SERVE YOU!**

## ARGENTINA

Coin-Arte  
Humboldt 374  
Buenos Aires  
Tel. 55-9272

## BELGIUM

Mr. Omer Vinckens  
c/o AUG. BULCKE AND CO  
SUCCRS LTD.  
Brouwersvliet 15  
Antwerp, Belgium  
Tel: 32 39 77

## CARIBBEAN AREA

Ramon Rodriguez  
Calle M. 1037  
Urb. M. Rivera  
Guaynabo, Puerto Rico  
Tel. 809 789-2844

## EAST AFRICA (KENYA, UGANDA)

M.R. (P) Godhani  
P.O. Box 11421  
Nairobi, Kenya, East Africa  
Tel. 25107

## GREAT BRITAIN

Myron Sugerman (U.K.) Ltd.  
30a, Brent Street  
Hendon, London N.W. 4  
Tel. 01-203-4847  
01-203-6098/9

## GREECE AND CYPRUS

Koukolias Bros. Ltd.  
42 Acharnon St.  
Athens 103, Greece  
Tel: 876 538

## MID-EAST

General Amusement Co.  
Ste. Generale Immobiliere Bldg.  
Rawche  
P.O. Box 4377  
Beirut, Lebanon  
Tel: 242528

## NETHERLANDS

Hommerson Amusement n.v.  
Palacestraat 6  
Scheveningen, Holland  
Tel: 55 01 98

## FRANCE

Henri V. Ormond  
1, Allee Des Orangers  
F 57-Marly-Les-Metz  
(France)  
Tel. (87) 68.10.10

## ITALY

Antonio Sorrentino  
Via Duomo 242  
Naples, Italy  
Tel. 324377



With the largest inventory  
of the newest and the most  
fascinating coin equipment  
manufactured

- JUKE BOXES
- SHUFFLE ALLEYS
- PIN BALLS
- BOWLERS
- GUNS
- BASEBALLS
- ARCADE EQUIP.
- UPRIGHTS
- BINGOS
- CONSOLES
- SLOT MACHINES
- POOL TABLES
- VENDING
- SOCCERS
- DIGGERS
- KIDDY RIDES
- ROTAMINT
- WALL MACHINES
- PUNCH BOARDS
- MINI SLOT CARS
- FOOSBALL-SOCCER
- HELICOPTER TRAINERS

As well as late used  
products from:

- AMERICAN SHUFFLEBOARD
- ALLIED LEISURE
- AMI
- SEEBURG
- ROCK-OLA
- WURLITZER
- BALLY
- GOTTLIEB
- WILLIAMS
- MIDWAY
- CHICAGO COIN
- SEGA
- UNITED
- H.A. FRANZ CO.
- AUTOBELL
- KEENEY
- AMF
- TAITO

**Exclusive distributor in the Western Hemisphere  
for P.R.W. (Sales) Limited. Now featuring:**

ATTACK



TANK ASSAULT



SUPER MISSILE

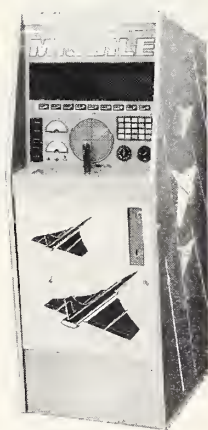

INDIANAPOLIS

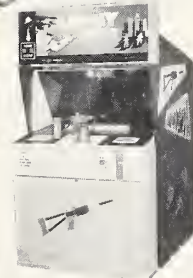

LOONEY SHOOT

# MYRON SUGERMAN INTERNATIONAL

140 Central Ave., Hillside, N. J. 07205

Our Warehouses are bulging with every  
conceivable kind of coin equipment,  
ready to produce for you . . .

CALL TODAY . . .

**201-923-6430**

Telex 13-8343



# 1969 Phonograph Export Report

Country	(Jan.-Dec. 1968)		(Jan.-Dec. 1969)	
	No. of Units	Dollar Volume	No. of Units	Dollar Volume
<b>NO. and CENTRAL AMERICA</b>				
Bahamas.....	110	\$72,694	100	60,259
Barbados.....	1	601	2	1,010
Bermuda.....	12	2,886	8	4,524
British Honduras.....	8	6,870	10	6,501
Canada.....	1,541	1,122,714	1,885	1,292,589
Costa Rica.....	65	45,834	181	118,092
Dom. Rep.....	18	4,782	27	5,550

El Salvador.....	21	10,185	47	13,078
F. Guiana.....	—	—	2	2,064
F. W. Ind.....	7	2,620	—	—
Guatemala.....	42	27,656	65	27,960
Haiti.....	5	850	6	500
Honduras.....	361	124,213	160	89,932
Jamaica.....	148	96,490	390	291,091
Lw. Ww. Is.....	12	7,711	20	11,611
Mexico.....	711	146,940	862	93,609
Neth. Antilles.....	43	31,286	43	42,031
Nicaragua.....	20	8,585	17	2,700
Panama.....	190	84,459	126	110,356
Trinidad.....	51	24,791	82	66,144

## SOUTH AMERICA

Argentina.....	61	38,144	41	40,000
Brazil.....	8	3,033	20	14,382
Chile.....	2	1,506	1	800
Colombia.....	2	470	3	830
Ecuador.....	61	11,957	9	6,447
Guiana.....	85	20,325	140	40,185
Peru.....	128	5,107	22	7,060
Surinam.....	6	5,450	17	14,826
Uruguay.....	4	1,000	4	836
Venezuela.....	1,525	427,943	566	485,123

## EUROPE

Austria.....	253	150,903	215	121,862
Azores.....	—	—	2	2,098
Belgium.....	3,692	2,724,443	2,207	1,686,705
Cyprus.....	48	22,387	16	10,093
Denmark.....	65	48,300	44	30,449
Finland.....	16	7,546	12	13,431
France.....	589	493,198	424	348,745
Greece.....	1,267	322,764	924	270,807
Ireland.....	26	7,538	19	5,350
Italy.....	2,473	1,792,969	1,523	1,349,459
Malta.....	2	1,756	3	2,678
Netherlands.....	591	449,209	360	279,921
Norway.....	29	21,184	23	17,324
Portugal.....	20	12,891	12	6,915
Spain.....	1	693	2	3,537
Sweden.....	90	68,715	23	16,524
Switzerland.....	318	258,565	121	104,947
United Kingdom.....	1,621	772,305	925	525,822
W. Germany.....	6,152	4,171,324	5,590	3,782,303

## ASIA

Hong Kong.....	460	272,977	143	99,838
Israel.....	47	9,790	24	10,300
Japan.....	6,020	3,447,769	6,075	3,194,230
Korean Rep.....	26	34,602	21	24,455
Lebanon.....	11	1,513	—	—
Malaysia.....	46	25,772	97	34,898
Nansei Is.....	218	79,037	220	120,369
Philippine Rep.....	349	62,451	59	19,990
Singapore.....	—	—	6	4,005
S. Vietnam.....	19	7,235	—	—
S. Yemen.....	1	802	—	—
Taiwan.....	1	820	2	1,724
Thailand.....	87	48,808	121	44,529

## AUSTRALIA

Australia.....	168	73,176	94	40,966
New Zealand.....	16	2,080	72	10,869
F. Pacific Is.....	4	1,010	6	600
T. Pac. Is.....	11	4,490	6	3,355

## AFRICA

Algeria.....	1	300	—	—
Canary Is.....	19	11,475	11	5,028
Kenya.....	102	28,012	216	39,987
Malagas.....	—	—	1	827
Malawi.....	4	1,982	—	—
Mozambique.....	9	3,645	3	2,641
Senegal.....	1	983	—	—
Tanzania.....	—	—	9	2,810
Uganda.....	98	25,854	283	47,265
Un. S. Africa.....	24	17,100	1	530
Zambia.....	5	3,359	1	707

**Grand Totals.....30,238 \$17,820,374 24,772 \$15,138,983**

## C. A. ROBINSON & CO.

THE WEST'S FINEST DISTRIBUTOR

ASK THE FOLKS AT MIDWAY, VALLEY AND BALLY

(Even Our Competitors Agree)

WRITE, WIRE OR CALL FOR PRICE LISTS  
OF THE VERY BEST VALUES IN USED EQUIPMENT.

2301 W. Pico Blvd.

Los Angeles, Cal. 90006

Telephone: (213) 385-7318

28 Years of Serving the operator

Happy Birthday to Both of Us



**"We Try Harder"**

With Quality Shipments All Over The World.

Exclusive Distributors For:

Rock-Ola • Midway • Gottlieb • Bally  
Chicago Coin • Sega • Nutting • Fisher  
Ali • Automatic Products • Westinghouse  
Avenco • Valley • Universal

Write For Current List of All Equipment including:

Phonographs • Arcade Equipment • 5 Balls  
Gun • Kiddie Rides • Vending Machines



**EMPIRE INTERNATIONAL**

Division of Empire Distributing, Inc.  
120 South Sangamon Street/Chicago, Ill. 60607  
Phone (312) 421-5200 • Cable Address "EMCOMACH"  
Branch Offices: Detroit • Grand Rapids • Green Bay



# 1969 Amusement Games Export Report



Country	(Jan.-Dec. 1968) Dollar Volume	(Jan.-Dec. 1969) Dollar Volume
<b>NO. and CENTRAL AMERICA</b>		
Bahamas	93,119	21,465
Bermuda	2,795	9,174
British Honduras	—	575
Canada	999,282	1,224,442
Costa Rica	—	250
Dominican Rep.	—	200
Guatemala	752	—
Haiti	—	10,000
Honduras	4,480	1,168
Jamaica	16,902	2,225
Lw. Wv. Is.	506	8,606
Mexico	71,596	46,918
Neth. Antilles	57,041	143,663
Nicaragua	690	—
Panama	143,600	215,629
Salvador	—	206
Trinidad	—	995
<b>SOUTH AMERICA</b>		
Argentina	11,542	52,064
Brazil	212	79,910
Colombia	7,804	—
Ecuador	6,039	970
French Guiana	1,567	795
Guyana	—	5,362
Paraguay	1,445	—
Surinam	—	978
Venezuela	72,860	61,542
<b>EUROPE</b>		
Austria	249,576	351,994
Azores	4,060	8,991
Belgium	3,910,941	4,901,882
Cyprus	7,651	2,112
Denmark	888,640	966,613
Finland	20,789	42,037
France	3,467,677	3,567,049
Gibraltar	4,299	3,742
Greece	85,869	66,181
Greenland	—	10,000
Ireland	242,253	334,205
Iceland	20,394	20,417
Italy	4,149,670	1,485,959
Malta	616	—
Netherlands	230,956	460,686
Norway	102,698	92,542
Portugal	17,670	98,082
Rumania	1,750	—
Spain	25,545	44,604
Sweden	591,276	2,565,803
Switzerland	7,504,718	4,268,877
Turkey	—	14,400
United Kingdom	5,373,805	2,832,745
W. Germany	5,106,279	5,763,294
Yugoslavia	—	685
<b>ASIA</b>		
Arabia	4,504	—
S. Arabia	408	—
Cambodia	—	1,531
Hong Kong	98,953	215,514
India	—	2,395
Indonesia	—	1,000
Iran	1,300	1,200
Iraq	—	883
Israel	1,353	29,830
Japan	2,000,932	2,408,870
Korean Rep.	92,670	279,900
Lebanon	12,369	18,132
Malaysia	4,713	10,710
Nansei Is.	59,991	160,757
Pakistan	6,194	5,481
Philippine Is.	148,158	129,445
Singapore	1,860	—
Taiwan	43,970	29,330
Thailand	104,539	16,316
S. Vietnam	291,175	223,061

Country	(Jan.-Dec. 1968) Dollar Volume	(Jan.-Dec. 1969) Dollar Volume
<b>AUSTRALIA</b>		
Australia	208,783	312,372
F. Pacific Is.	8,694	22,506
New Zealand	—	4,078
T. Pacific Is.	750	699
<b>AFRICA</b>		
Afrs. Is.	1,106	—
Canary Is.	76,217	79,168
C. Af. Rep.	318	—
Ethiopia	2,935	3,600
Gabon	1,310	—
Ivory Coast	—	24,600
Kenya	1,127	13,036
Liberia	—	550
Libya	16,575	24,481
Mozambique	10,074	1,595
Morocco	—	17,050
Nigeria	—	14,500
Senegal	4,714	—
Tanzania	1,575	3,192
Uganda	1,570	—
Zambia	2,444	44,956
U. So. Africa	13,647	9,391
Other Countries	117,042	—
<b>Grand Total</b>	<b>\$34,618,232</b>	<b>\$33,900,166</b>

## LONDON



## COIN

### Machines Limited

(one of the ENTAM Group of Companies)  
22-24 Bromells Road, S.W.4. Tel: 01-720 1202/3/4

SECOND TO NONE  
IN THE U.K.  
SOLE DISTRIBUTORS  
FOR  
GOTTLIEB  
SEGA  
AND MANY  
OTHER LEADING  
COIN MACHINE  
MANUFACTURERS

**IMPORT — EXPORT  
OUR  
SPECIALITY**

**THE NAME MAY BE NEW  
BUT THE EXPERIENCE IS VAST**

Contact **THE GRECO BROS.**

★ For ALL Of Your ★  
**Domestic and Export Needs**

Exclusive Distributors  
For NSM Phonographs  
Prestige 160 • Consul 130  
Midway  
United Billiards

*We are STILL the Greatest!*  
**GRECO BROS. AMUSEMENT CO.**

MAIN STREET, GLASCO, N.Y.  
CHerry 6-8700

1288 BROADWAY, ALBANY, N.Y.  
HO 5-0228

# 1969 Vending Machines Export Listing

Country	(Jan.-Dec. 1968)		(Jan.-Dec. 1969)		Ireland					
	No. of Units	Dollar Volume	No. of Units	Dollar Volume						
<b>NO. and CENTRAL AMERICA</b>										
Bahamas	141	\$45,871	420	103,435	2	498	2	864		
Barbados	29	13,282	9	5,583	427	107,414	461	125,081		
Bermuda	134	43,017	145	61,048	1,825	489,998	747	165,393		
Canada	15,346	4,252,514	14,875	4,563,520	774	161,828	481	139,832		
Costa Rica	107	12,555	106	8,605	9	5,337	88	3,836		
Dom. Rep.	57	27,327	76	18,555	211	110,968	254	102,947		
El Salvador	1,026	26,779	63	7,555	784	444,043	1,194	546,571		
Fr. West Indies	20	12,103	46	61,576	171	44,406	95	70,267		
Guatemala	407	8,490	97	31,362	3,857	1,551,700	3,014	1,225,143		
Haiti	—	—	8	1,956	9,798	1,457,417	3,400	1,520,653		
Honduras	108	60,125	66	28,297	<b>ASIA</b>					
Jamaica	134	52,992	53	13,359	10	7,114	10	6,882		
Lw. Wv. Is.	7	3,864	8	5,211	4	2,070	—	—		
Mexico	647	184,003	796	69,121	—	—	20	10,007		
Neth. Antilles	86	22,892	15	6,881	—	—	4	1,767		
Nicaragua	50	525	117	3,750	531	50,941	89	90,549		
Panama	814	341,699	380	152,527	5	1,513	6	212		
Trinidad	102	57,849	134	64,712	6,137	1,390,172	2,179	554,107		
<b>SOUTH AMERICA</b>					—	—	25	6,874		
Argentina	7	1,890	3	3,414	354	221,773	113	71,673		
Brazil	—	—	3	1,320	142	95,763	—	—		
Br. Guiana	79	42,175	32	14,821	—	—	32	11,321		
Chile	—	—	3	1,320	93	37,377	117	60,956		
Colombia	5	4,865	62	27,570	347	209,407	127	63,433		
Ecuador	1	1,000	2	1,400	6	3,406	—	—		
Fr. Guiana	8	5,110	5	2,190	—	—	35	31,431		
Peru	16	7,970	6	3,077	—	—	1	619		
Surinam	—	—	24	15,049	15	630	—	—		
Venezuela	562	215,032	971	531,619	<b>AUSTRALIA</b>					
<b>EUROPE</b>					1,437	117,936	1,459	235,045		
Austria	120	48,557	63	23,925	53	14,120	—	—		
Belgium	7,801	1,464,023	4,078	1,762,292	6	1,120	—	—		
Denmark	42	10,189	340	54,953	—	—	38	15,775		
Finland	70	48,801	78	43,955	<b>AFRICA</b>					
France	2,651	388,397	1,670	448,337	—	—	11	2,560		
Greece	—	—	58	7,668	15	12,366	19	16,225		
Iceland	—	—	6	3,680	1	540	—	—		
					151	58,929	165	83,658		
					<b>Grand Totals</b>		57,742	\$14,002,682	39,004	\$13,317,725

## Cleveland Coin International

We sell only the best money-making equipment in the United States and Abroad

**CUSTOMER SATISFACTION GUARANTEED**

You can be sure that every piece of equipment is thoroughly shopped. Or, if you prefer, equipment is available in a complete and clean condition.

Cleveland Coin International always has in stock a complete selection of every make of phonographs, games, arcade and vending equipment. **YOU NAME IT, WE'VE GOT IT!**

**PHONOGRAPHS**

**AMUSEMENT GAMES**

**ARCADE EQUIPMENT**

**VENDING EQUIPMENT**

ALL-TECH Industries  
AMERICAN Hand Dryers (electric)  
AMERICAN shuffleboards & Pool Tables  
AUTOMATIC PRODUCTS  
Smokeshop & Candyshop  
COIN-OPERATED Parking Meters  
KLOPP Coin Sorters & Counters

**FACTORY DISTRIBUTORS FOR:**

AMERICAN MACHINE & FOUNDRY  
American Speedway  
FISCHER Pool Tables  
GOTTLIEB Pin Games  
SEGA Enterprises  
HARMON Package Vendors  
IRVING KAYE Pool Tables

MIDWAY Baseball Games  
NUTTING Associates  
Computer Quiz  
NATIONAL Shuffleboards & Pool Tables  
NORTHWESTERN Vendors

VALLEY Pool Tables  
WESTINGHOUSE-UNIVERSAL  
Candimat  
WILLIAMS  
Amusement Games  
WURLITZER  
Music Machines  
Remote Wallboxes

We can supply you with parts for all the machines we handle. For prompt and dependable service, place your export or domestic orders with

**Cleveland Coin International**

2029 Prospect Ave., Cleveland, Ohio 44115 Cable: CLECOIN (216) TO 1-6715

**WRITE FOR OUR NEW EXPORT CATALOGUE AND PRICE BULLETIN**

The Name of the Game  
is Leadership:

# Williams leads the world in Action Profit Games

Williams gives you  
top profits with a complete line for  
• every location • more excitement • more traffic

When it's a winning idea it's from...



*Williams*<sup>®</sup>  
Action  
The • Profit • People  
Games

# TAITO TRADING CO.

TOKYO C.P.O. BOX 1164 Cable "Epra"

Manufacturers & Exporters

Prompt Supply of  
new Equipment.

DRIVE GAMES

Super Road-7  
Drive Test 35

GUN NOVELTIES

Guided Sub Missile  
Caliber 50  
X-08  
Battle King

New and used machines

TAITO Basketball  
TAITO Periscope  
TAITO Ghost Gun  
TAITO Sportsman  
TAITO Merchandise  
Payout Machines.

WRITE US and we'll give you  
OUR PRICES and  
DELIVERY TIMES.

Exclusive Distributors of Seeburg, Gottlieb



## New Super Road-7

The 1970 generation  
of Road Race Machines.

25¢ play.

OUR NEW TOP CASH EARNER  
FOR ANY LOCATION.  
New racing and accident  
features.

Road-7



## GROWING BIGGER EVERY YEAR

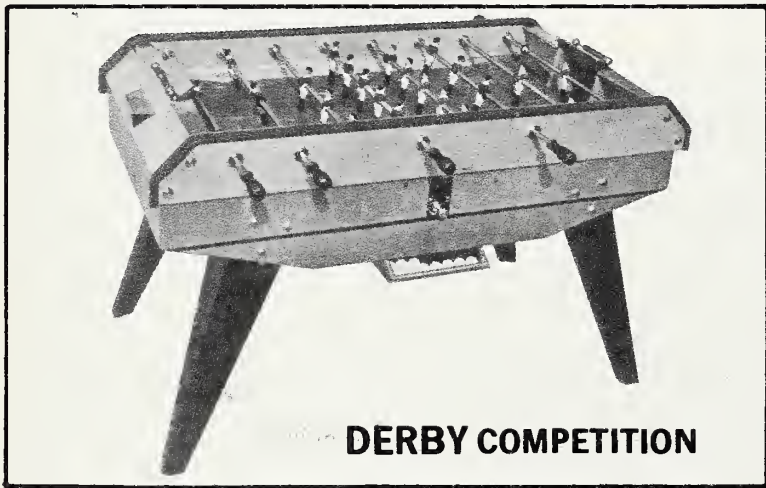

DERBY COMPETITION

The Finest Coin-Op Soccer  
Table On the Market Today.

MFG. BY Ets. **RENE PIERRE**

39 RANCHOT • JURA, FRANCE

**SOME USA & CANADIAN TERRITORIES  
AVAILABLE TO DISTRIBUTORS**

EXCLUSIVE REPRESENTATIVE FOR USA AND CANADA

**CHARLES RAYMOND & CO., INC.**

381 PARK AVE. SOUTH • NEW YORK, NY 10016 • (212) MU 9-0547

# \$62,356,874 GROSS DOLLAR VOLUME 1969

## COIN MACHINE EXPORT SALES

### DIVISION BREAKDOWN

<u>PHONOGRAPHS</u>		<u>VENDING</u>		<u>AMUSEMENTS</u>
Units	Dollars	Units	Dollars	Dollars
24,772.....	\$15,138,983	39,004.....	\$13,317,725	\$33,900,166

### TOP TEN IMPORT COUNTRIES

#### PHONOGRAPHS

COUNTRY	Units	Dollars
West Germany	5,590	\$3,782,303
Japan	6,075	3,194,230
Belgium	2,207	1,686,705
Italy	1,523	1,349,459
Canada	1,885	1,292,589
United Kingdom	925	525,822
Venezuela	566	485,123
France	424	348,745
Jamaica	390	291,091
Netherlands	360	279,921

#### VENDING

COUNTRY	Units	Dollars
Canada	14,875	\$4,563,520
Belgium	4,078	1,762,292
West Germany	3,400	1,520,653
United Kingdom	3,014	1,225,143
Japan	2,179	554,107
Sweden	1,194	546,571
Venezuela	971	531,619
France	1,670	448,337
Australia	1,459	235,045
Netherlands	747	165,393

#### AMUSEMENTS

COUNTRY	Dollars
West Germany	\$5,763,294
Belgium	4,901,882
Switzerland	4,268,877
France	3,567,049
United Kingdom	2,832,745
Sweden	2,565,803
Japan	2,408,870
Italy	1,485,959
Canada	1,224,442
Denmark	966,613

# EUROPEAN MANUFACTURERS

■ Coin-Operated Phonographs and Amusement Machines ■

## BELGIUM

**AUTOMATENFABRIEK JODEK**  
Koophandelstraat 2  
Wetteren

**DISCOMATIC**  
Lange Kievstraat 83  
Antwerp

**RENOTTE**  
Rue Gustave Masset 83  
Gembloux

**M. VAN EMDEN (NAC)**  
Parijsstraat 1  
Brussels

## DENMARK

**STEFANSEN**  
Broholms Alle 5a  
Copenhagen

**PAUL KRISTENSEN**  
Damjus Boulevard 55  
Copenhagen

**ESBJERG UNDERHOLDING  
ANTOMATENFABRIK**  
Gamie Faergevej,  
Esbjerg

## FRANCE

**ETS. BRONZIZI**  
34-36 Rue Desire Vienot  
Bagnolet

**ETS. RENE PIERRE RANCHOT**  
18 Rue Mazagran  
Paris

**STE. SECMAU (STELLA)**  
4 Rue Scipion  
Paris

**ETS. LEDRU**  
49 Rue Michelet  
02-St. Quentin

**ETS. MERCHANT**  
7-9 Rue Voltaire  
Levallais

**EDITIONS RALLY**  
96, Avenue Saint Lambert  
06 Nice.

**SOCIETE FRANCAISE DE RADIO**  
72 Rue Marceau  
Montreuil

## GERMANY

**AUTOMATENBAU FOERSTER Bmbh**  
Hirschenstrasse 16  
Furth, Bavaria

**TH. BERGMANN & CO.**  
Eimsbitteler Strasse 64  
Hanburg-Altona

**BEROMAT Gmbh**  
Tauenzienstrasse 6  
Berlin 30

**CANTEEN AUTOMATENBAU Gmbh**  
Neu-Isenburg  
Rathenaustrasse 53  
Frankfurt

**DEUTSCHE WURLITZER Gmbh**  
4971 Hüllhorst  
Westfalen

**EICHOFF-WERKE Gmbh**  
Ludenscheid 1  
Westfalen

**GUNTER WULFF APPARATEBAU**  
Tauenzienstrasse 6  
Berlin 30

**DR. HANSBERG**  
Bliesmühle 1  
Neunkirchen/Saar

**WILHELM HARTING**  
Marienburger Strasse  
Postfach 104 und 106  
4992 Espelkamj-Mittwald

**LEONHART**  
8381 Aufhausen  
Landau/Isar

**LOEWEN-AUTOMATEN Gmbh**  
Am Frelldhof  
Bingen am Rhein

**NOVA APPARATE Gmbh**  
24 Semperstrass  
2 Hamburg 39

**NSM APPARATEBAU Gmbh**  
Alzeyer Strasse 51  
Bingen am Rhein

**RHENANIA-AUTOMATEN Gmbh**  
Oberwerth-Rheinau 2  
Koblinz

**WINKLER AUTOMATEN Gmbh**  
Hohenzollernring 2-10  
Cologne

## HOLLAND

**JOS. VAN OSCH**  
14 Kerkstraat  
Kerkdriel

## ITALY

**C. ALBERTAZZI**  
Corso Tortona 7  
Turin

**ALFAMATIC**  
22 Via Corvisieri  
Rome

**E. BIANCHI VELO**  
Via Fantoli 11  
Milan

**INNOCENTI (CINEBOX INT'L)**  
7 Via Marco Polo  
Milan

**ELETTROGIOCHI**  
2 Via del Sansovino  
Florence

**(BREVETTI) F.A.N.S.A.**  
Via Monte Rosa 35  
Turin

**GAETANO SPATAFINA**  
10 Via Maso Di Vanco  
Florence

**NOVARMATIC**  
3 Via Margotti  
Empoli/Cortenuova

**SIDAM**  
76 Corso Siracusa  
Turin

## UNITED KINGDOM

**A.M.F. of LONDON**  
AMF Bldg.  
25 Old Burlington St.  
London, W. 1

**AINSWORTH CONSOLIDATED IND. LTD.**  
Aristocrat House  
Rookery Way  
London, N.W. 9

**AUTOMATIC COIN EQUIPMENT (CARDIFF) LTD.**  
Ace Industrial Holdings Limited  
Ace House, Talbot Green, Glamorgan,  
South Wales

**BELL FRUIT MFG. CO. LTD.**  
Leen Gate, Lenton, Nottingham  
Nottingham

**BRYANS WORKS**  
Kegworth,  
Derby

**CHICAGO AUTO SUPPLY CO.**  
10 Cole St  
London, S.E. 1

(Con't on next Page)

## Apart we make beautiful music together

The Cameron Solid-State Stereophonic Phonograph is the world's finest Phonograph. Its revolutionary feature is the CAMERON MUSIC SYSTEM. Which means the Cameron can be tailored, in moments, to fit any location.

Place two sets of twin speakers anywhere in the area you wish to cover with the great CAMERON sound and customers will get true stereophonic sound. The Selector head can be wall mounted anywhere you want to get maximum play. Hit features, Little L.P.'s and Stereo get lots of play time.

Incorporate the play unit, housed in an attractive cabinet, as part of your location furniture or tuck it away, out of sight, in store room or cellar.

There's never been another Phonograph to match the CAMERON SOUND so before you consider any Phonograph make sure you hear the CAMERON . . . all apart and making beautiful music.

For further information contact:  
Ace Industrial Holdings Limited,  
Ace House, Talbot Green, Glamorgan,  
South Wales, Gt. Britain.  
Telephone: Ely Valley 2561 Telex: 49581.

Manufactured under licence from  
Cameron Musical Industries Ltd.  
Port Washington, New York, U.S.A.



**MIAMCO** (A Division of the Vendo Company) Distributors for America & Canada

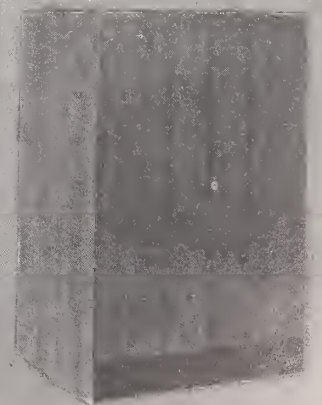
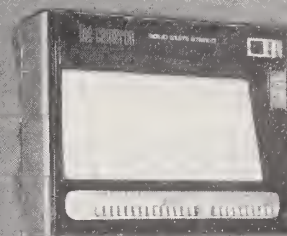
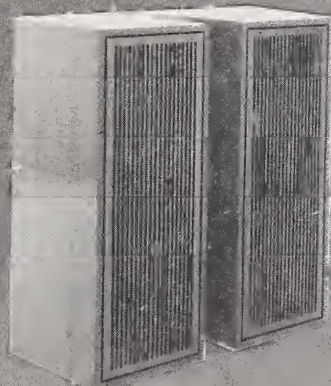

# FABULOUS..But what do you do for an encore after Periscope Missile Grand Prix and Combat

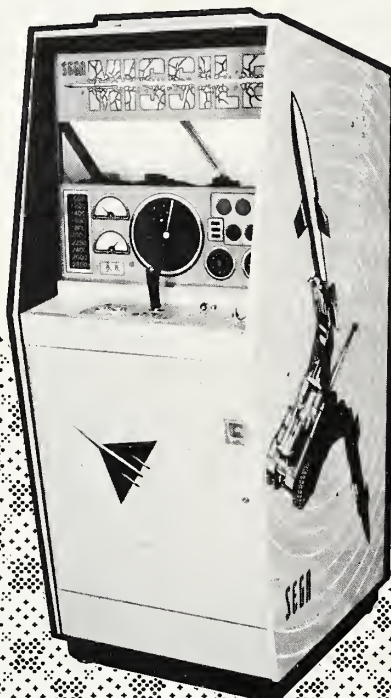
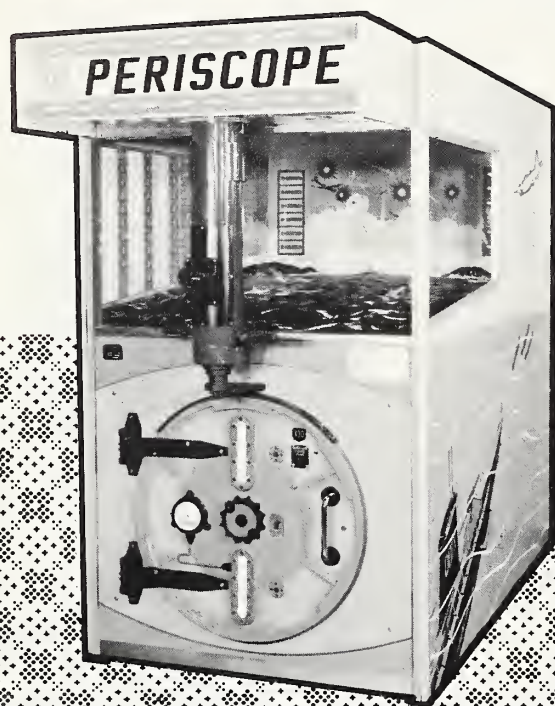

## MAJOR OVERSEAS DISTRIBUTORS

### UNITED STATES

BOSTON Trimount Automatic Sales Co. 888 Providence Hwy., Deadham, Mass. 92026  
 CHICAGO Empire Distributing Inc. 120 S. Sangamon St. at Adams, Chicago, Ill.  
 CLEVELAND Cleveland Coin International 2025-29 Prospect Ave., Cleveland, Ohio 44115  
 HONOLULU Hawaiian Amusements Co. 905 Ahna St., Honolulu, Hawaii 96819  
 LOS ANGELES A.C.A. Sales & Service 2891 Pico Blvd., Los Angeles, Calif. 90006  
 MINNEAPOLIS Lieberman Music Co. 9549 Penn. Ave., South, Minneapolis, Minn. 55431  
 NEW ORLEANS New Orleans Novelty Co. 1055 Dryades Street, New Orleans, La. 70113  
 NEW YORK Albert Simon, Inc. 587 Tenth Avenue, New York, New York 10036  
 NORFOLK Southeastern Distributors Inc. 601 Woodis Avenue, Norfolk, Va. 23510  
 OKLAHOMA CITY Culp Distributing Co. 614 West Sheridan Ave., Oklahoma City, Okla. 73102  
 OMAHA Central Distributing Co. 1209 Douglas St., Omaha, Nebraska 68102  
 PHILADELPHIA Bannner Specialty Co. 1213-31 N. Fifth St., Philadelphia, Pa. 19122  
 PORTLAND Dunis Distributing Co. 1140 S.E. 7th Ave., Portland Oregon 97214  
 SEATTLE Music-Vend Distributing Co 100 Elliot Ave., West, Seattle, Wash. 98119  
 ST. LOUIS Central Distributing Inc. 2315 Olive St., St. Louis, Missouri 63103

### CANADA

MONTREAL Laniel Automatic Machines Inc. 151 Chemin Rockland, Montreal 16, Que.  
 TORONTO New-Way Sales Co. 1257-61 Queen Street West, Toronto 3, Ontario  
 VANCOUVER Dale Distributing (B.C.) Ltd. 1110 Homer Street, Vancouver 3

### EUROPE

ANTWERP Belgian Amusements Co., Ltd. 187 Lange Leem St., Antwerp, Belgium  
 COPENHAGEN Oscar Siesbye A/S 5 Palaisgade, Copenhagen K. Denmark  
 FLORENCE Bally Mediterranea Via Della Villa Demidoff, 14R, Florence, Italy  
 HAMBURG Seevend Automaten Vertriebs Carl-Petersen-Str. 70, Hamburg 26 Germany  
 HANNOVER Wulff Automaten GmbH. 3-5 Smalianwinkel Hannover 3, W. Germany  
 HELSINKI Oy Vendor AB Siltasaarenk 18, P.O.B. 53 041, Helsinki 53, Finland  
 LONDON London Coin Machines Ltd. 22/24 Bromells Rd., Clapham Common, London S.W. 4  
 MADRID SEGA S.A. Adela Balboa, No. 3, Madrid 20, Spain  
 OSLO Frigoterm, A/S P.O.Box 21, Sandvika, Oslo, Norway  
 PARIS Socodimex S.A. 1 Quai de Grenelle, Paris 15, France  
 STOCKHOLM Freius Danneman & Co. A/B Box 43, S-181 21 Lidingo 1, Sweden  
 VIENNA Auwa M.B.H. Karntner Strasse 1, 1010 Vienna 1, Austria  
 ZURICH Musikvertrieb AG Badenerstrasse 555, Zurich, Switzerland



MANUFACTURED BY  
**SEGA Enterprises Ltd.**

P.O. BOX 63 TOKYO AIRPORT POST OFFICE  
 TOKYO 149 JAPAN Cable: Segastar

WORLDWIDE AGENTS

**Club Specialty Overseas Inc.**

APARTADO 133 PANAMA 1, R. de P.



## EUROPEAN MANUFACTURERS

(United Kingdom con't.)

**CLUB MECHANISMS LTD.**  
List House,  
Long Melford,  
Sudbury,  
Suffolk.

**AL CROMPTON AMUSE. MACH. LTD.**  
166-172 High Street  
Ramsgate, Kent

**DITCHBURN EQUIPMENT, LTD.**  
Dack Road  
Lytham, Lancashire

**GOLDING AUTOMATICS, LTD.**  
37 Landon Road  
Marks Tey, Calchester  
Essex

**EDWIN HALL & CO.**  
67 Besley Street  
Landon, S.W. 16

**JUBILEE PRODUCTS**  
28 Rushgrave Ave., Hendon,  
Landon, N.W. 9

**KRAFT OF LONDON**  
158, Stoke Newington Road,  
Landon, N. 16.

**LONDON COIN MACHINES LTD.**  
22/24, Bromells Road,  
Landon, S.W. 4.

**MAYFIELD AUTOMATICS, LTD.**  
Mayfield Mill, Cawhill,  
Chaderton, Lancashire

**MILLERS, LTD.**  
Narthurberland St.  
Narthur Shields

**MILLS BELL-O-MATIC, LTD.**  
45 Leesans Hill,  
St. Paul's Gray, Kent

### Foreign Representatives:

**MILLS NOVELTY CO., LTD.**  
Weir Mill, Manchester Rd.  
Ashton-Under-Lune,  
Lancashire

**MORRIS SHEFRAS & SONS, LTD.**  
64 Baraugh High Street  
Landon, S.W.E. 1

**PHONOGRAPHIC EQUIPMENT LTD.**  
Phonographic House,  
North Block,  
Cricklewood Trading Estate,  
Claremont Road,  
Landon, N.W. 2.

**WHITTAKER BROS. (SHAW) LTD.**  
Shaw, Oldham,  
Lancashire

## U.S. Phono Manufacturers' World Wide Representatives

### ROCK-OLA MFG. CORPORATION

800 North Kedzie Ave.  
Chicago, Illinois  
Export manager: Art Janacek

**BRABO CORPORATION**  
Kronenburgstraat 55  
Antwerp, Belgium

**CAPITOL ENTERPRISES**  
P.O. Box 253  
Monrovia, Liberia  
West Africa

**COMPANHIA ULTRAMARINA de COMER-  
CIA, LTDA.**  
Avenida da Republica No. 27  
P.O. Box 1562  
Lourenco Marques  
Portuguese East Africa

**DITTA MANITOBA, S.R.L.**  
Via Meravigli, 16  
20123 Milano

**DUARTE INTERNATIONAL SALES CO.,  
INC.**  
835 East 31st St.  
Los Angeles, California 90011

**ESTEVE INTERNATIONAL CORPORATION**  
Ponce de Leon No. 724  
Hato Rey, Puerto Rico 00919

**GILLESPIE & CO. of NEW YORK, INC.**  
2 Broadway  
New York, N.Y. 10004

**GODDARD NOVELTY CO., PTY. LTD.**  
265 Broadway  
Sydney, 2007, Australia

**GOURGUEN ABRAHAMIAN AUTOMATIC  
MUSICAL INSTRUMENTS OPER.**  
122 Shiraz St.  
North of Bahar Ave.  
Tehran, Iran

**GLOBE INDENTING HOUSE**  
P.O. Box 987  
Kampala, Uganda  
East Africa

**GUAM MUSIC, INC.**  
Blake Building  
P.O. Box 631  
Agana, Guam 96910

**THE HOUSE OF COIN, LTD.**  
8861 - 63rd Ave.  
Edmonton, Alberta, Canada

**INDUSTRIAS NACIONALES de SONIDO,  
S. A.**  
Calzada Mexico Xochimilco #4861  
Mexico 22, D. F., Mexico

**INTERNATIONAL MERCHANTS CO., LTD.**  
P.O. Box 544  
Georgetown, Guyana  
South America

**ISTHMIAN AMUSEMENT CORPORATION**  
P.O. Box 465  
Curundu, Canal Zone

**LANIEL AUTOMATIC MACHINES, INC.**  
151 Rockland Road  
Town of Mount Royal  
Montreal 16, Quebec, Canada

**MORCOIN COMPANY, LTD.**  
564 Interior - 1  
Echague Street  
P.O. Box 3162  
Manila, Philippines

**NEW-WAY SALES COMPANY**  
1257-61 Queen Street, W  
Toronto, Ontario, Canada

**NOVA APPARATE GmbH & CO.**  
24, Semperstrasse  
Hamburg 39, Germany

**SEGA ENTERPRISES, LTD.**  
Tokyo International Airport  
P.O. Box 63  
Tokyo, Japan 149

**STIM BOTTLING FACTORY**  
P.O. Box 277  
Bahrain  
Arabian Gulf

**RAYMOND WEIR**  
Regent Street, West  
Belize, British Honduras

**WINNIPEG COIN MACHINE COMPANY**  
768 Notre Dame Ave.  
Winnipeg 3, Manitoba, Canada

## ROWE

**ROWE INTERNATIONAL**  
Troy Hills Road  
Whippany, New Jersey  
(Div. Of Triangle Industries)

All requests for information concerning export of Rowe equipment and export distributorships, licensees and branches should be addressed to: J. Morfin, Ass't. Director Export Sales, Rowe International, 75 Troy Hills Road, Whippany, New Jersey. Cable Address: Rowend Whippany.

# MONDIAL



## WORLD'S LARGEST EXPORT ORGANIZATION OF COIN-OPERATED AMUSEMENT EQUIPMENT

SERVING WORLD MARKETS THROUGH OUR NETWORK  
OF AUTHORIZED DISTRIBUTORS

*Exclusive Export Distributor for:*

**D. GOTTLIEB & CO.**

*Watch for Special Announcement from Mondial*

**MONDIAL COMMERCIAL  
CORPORATION**

350 FIFTH AVE., N.Y.C.  
Tel: (212) 947-5659  
Cable: MODINOV New York  
Telex: 421810



# U.S. Phonograph Mfrs.' World Wide Representatives

## SEEBURG

**SEEBURG INTERNATIONAL INC.**  
1500 N. Dayton St.  
Chicago, Illinois 60622  
Cable Address  
Seevend Chicago  
Vice President, export, George Gilbert  
Foreign Representatives:

**AMCO SERVICES, LTD.**  
499 Commercial Drive  
Vancouver, B. C.

**CARIBE MUSIC DIST., INC.**  
Betances, 23  
Bayamon, Puerto Rico 00619

**E. F. DEBROT, INC.**  
Box 152  
Aruba, Netherland Antilles  
Mr. J. M. Debrot

**DISTRIBUIDORAS UNIDAS, C. A.**  
Avenida Mexico No. 229  
Caracas, Venezuela

**FUJI KADEN CO. LTD.**  
No. 15-12, 6-Chome  
Sotokanda, Chiyoda-Ku  
Tokyo, Japan

**GALERIA MUSICAL LTDA.**  
Apartado 5407  
San Jose, Costa Rica

**MAHARLIKA CORPORATION**  
731 Aurora Blvd., Quezon City  
P.O. Box 2952, Manila

**MARKIE JOHN'S AGENCY**  
Point Fortin  
Frisco Junction  
Trinidad, West Indies

**MANUFACTURERA DE SINFONOLAS, S.A.**  
Avenida Jardin 330  
Mexico 15, D. F., Mexico

**MUSIKVERTRIEB, A. G.**  
Badenerstrasse 555  
Zurich, Switzerland

**PAN NORDIC AUTOMATIC A/S**  
Vesterbrogade 188  
Copenhagen, Denmark

**PAN NORDIC AUTOMATION**  
P. O. Box 8  
43040 Saro, Sweden

**PHILLIPINE AMUSEMENT ENTERPRISES, INC.**  
731 Aurora Blvd.  
Quezon City, Philippines

**P. R. W. (SALES) LTD.**  
Phonographic House—North Block  
Cricklewood Trading Estate  
Claremont Road  
London N.W. 2, England

**PUNATER SONS (A) LTD.**  
Punater House  
Grogan Road West  
Nairobi, Kenya

**REFCO, S.A.**  
Via Espana Braniff Building  
Panama 5, R.P.

**SEEBEN N. V.**  
Vredebaan, 63/65  
Mortsel-Antwerp, Belgium

**SEEBURG (AUST.) PTY., LTD.**  
136 Nelson Street  
Annandale, Australia, N.S.W.

**SEEVEND AUTOMATEN VERTRIEBS, G.M.B.H.**  
Carl Petersen Strasse 70/76  
2 Hamburg 26, Germany

**SEEROME, S.P.A.**  
Viale Lombardia 68  
Milan, Italy

**C. J. SHEILS, LTD.**  
1760 Midland Ave.  
Toronto (Scarborough), Ontario

**SOCOMIDEX, S. A.**  
1 Quai De Grenelle  
Paris 15, France

**TAITO TRADING CO., LTD.**  
Rm. 206-8 Fukoku Building  
Uchisaiway-Cho  
Chiyoda-Ku, Tokyo, Japan

**PETER THOMAS**  
Avenida Universitaria  
San Salvador, El Salvador

## WURLITZER

**The Wurlitzer Co.**  
North Tonawanda, N.Y.  
(716) NX-3-2500  
Bob Bear, Sales Manager  
(Distributors)

### Foreign Representatives

**ALOUETTE AMUSEMENT QUEBEC LTEE.**  
8505 Delmeade Ave.  
Montreal 307, Que., Canada

**THE AUTO SUPPLIES COMPANY**  
30, Hadfield & Lombard Sts.  
Georgetown, Guyana

**BORINQUEN WHOLESALE & FINANCE CORP.**  
400 Comercio St.  
San Juan, Puerto Rico 00904

**CARRIBBEAN MOTORS CO., C. POR A.**  
Apartado #52  
Santo Domingo, Dominican Republic

**CARLOS CORBIN**  
Paseo Colon #3073  
San Jose, Costa Rica

**CASA EDISON**  
Calle Delgado No. 318  
San Salvador, El Salvador

**COMPANIA IMPORTADORA COMERCIAL, S.A.**  
P. O. Box 124  
Tegucigalpa, D.C., Honduras

**CURACAO TRADING CO., INC.**  
P. O. Box 368  
Port-au-Prince, Haiti

**CURACAO TRADING CO., (SURINAM) INC.**  
P. O. Box 1819  
Paramaribo, Surinam

**DALE DISTRIBUTING (B.C.) LTD.**  
1110 Homer St.  
Vancouver 2, B.C., Canada

**Look inside the New Fischer Billiard Tables...see the difference**



**The Empress Series**

two sizes  
52" x 92" and  
59" x 105"

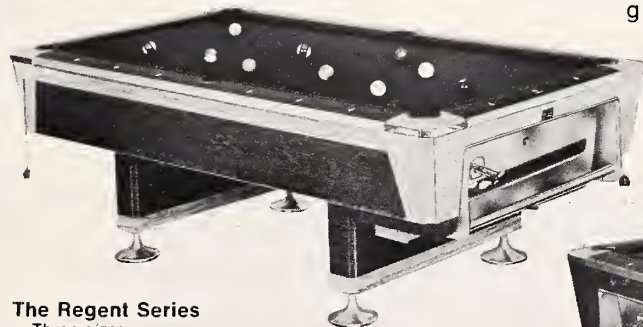

**The Regent Series**

Three sizes  
48" x 84"  
52" x 92" and 56" x 101"

When you look at a Fischer table, it's beautiful. No doubt about it. It catches your eye . . . and the eyes of your customers. It attracts people to play more pool. And that's great . . . but it's only half the story.

Just as important to you is how Fischer tables stand up under the abuse of heavy play. That's when you need to look inside. Check the all-metal self-cleaning open center runways, new condensed steel reinforced mechanism drawer, security controlled large cash box with metal housing and non-resettable coin counter. Check the straight grained, knot free lumber, the reinforcing, the heavy cast corners, the Formica top rails. That keeps you in business, night after night, without service problems. That's quality . . . that's Fischer.

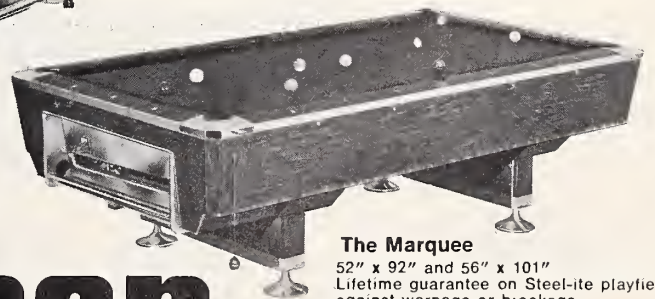

**The Marquee**

52" x 92" and 56" x 101"  
Lifetime guarantee on Steel-ite playfield  
against warpage or breakage

**fischer**

MANUFACTURING CO. INC. 

A SUBSIDIARY OF A.G. SPALDING & BROS. INC. / TIPTON, MISSOURI 65081 / PHONE 816/433-5531

**B  
E  
L  
L  
A  
M**

**FOREIGN BUYERS**

*WHEN YOUR NEEDS ARE  
COIN OPERATED MACHINES*

**BELAM**  
*is* **BEST**

THE ONLY AMERICAN FIRM SPECIALIZING IN  
EXPORT WITH WAREHOUSES IN  
**NEW YORK • ANTWERP**

**PHONOGRAPHS**  
SEEBURG AMI  
WURLITZER ROCK-OLA  
**FLIPPERS**  
GOTTLIEB & WILLIAMS  
**POOL TABLES**  
**PHOTO COPY MACHINES**  
**ARCADE GUNS**  
NEW — USED

*Be Convinced Try BELAM!!*

**R.H. BELAM COMPANY, INC.**

51 MADISON AVE.  
NEW YORK, N.Y. U.S.A.  
TEL: (212) 689-5633

EUROPEAN CUSTOMERS  
R.H. BELAM CO. (OVERSEAS)  
17a KORTE WINKEL STRAAT  
ANTWERP, BELGIUM



*cable/write for price list, catalogs and details*

**U.S. Phono Mfrs.'**

**World Wide  
Representatives**

(Wurlitzer con't.)

DALE DISTRIBUTING (B.C.) LTD.  
Unit #11-306 Rexdale Blvd.  
Rexdale, Ont., Canada

DISCO CENTRO LTDA.  
Apartado 4580  
San Jose, Costa Rica

JOHN ELLIOTT LIMITED  
144 King St.  
Kingston, Jamaica

DANIEL GENEST  
755 Montfort  
Jonquiere, Que., Canada

HOME FURNITURE COMPANY  
P. O. Box 331  
Nassau, N.P., Bahamas

FERNANDO HORVILLEUR & CIA., LTDA.  
405 Calle Central Oeste  
Managua, Nicaragua

INDUSTRIAS CALLAO, S.A.  
Apartado 3720  
Lima, Peru

INTERCOMERCIAL VENEZOLANA, C.A.  
(INTERVANCA)  
Apartado Chacao 61125  
Avenida Francisco Miranda  
Edificio Galerias Miranda  
Chacao — Estado Miranda  
Caracas, Venezuela

INTERNACIONAL CIA., LTDA.  
Ballen 307  
Guayaquil, Ecuador

INTERNATIONAL PHONOGRAPH COMPANY  
P. O. Box 859  
20, Eastern Main Road  
Leventille, Trinidad

ISLAND INTERESTS, LTD.  
P. O. Box 5432  
Nassau, N.P., Bahamas

M.A.M. NACIONAL  
P. O. Box 196  
6 a. Ave. y 24 Calle, Zona 4  
Guatemala, Guatemala

THE MUSIC MART  
66 Orange St.  
Kingston, Jamaica

MUSICAL  
13 Calle 9-62, Zona 1  
Guatemala, Guatemala

J.A. NIEUW  
P. O. Box 84  
Oranjestad, Aruba  
N.W.I.

PANAMERICANA DE MUSICA S.A.  
P.O. Box 3359  
Panama City, Panama

REGINALD PITMAN  
Serpentine Road  
Pembroke, Bermuda

WILLIAM POUND AGENCIES LTD.  
P. O. Box 1173  
St. John's Nfld., Canada

PUERTO RICO MUSIC CORP.  
Plaza de las Americas  
Hato Rey, Puerto Rico

SALA CHOPIN S.A.  
Av. Alvaro Obregon 302  
Esq. Oaxaca  
Mexico 7, D.F., Mexico

SANTIAGO CASTILLO, LIMITED  
P.O. Box 69  
Belize, British Honduras

SISTEMAS ELECTRONICOS CENTROAMER-  
ICANOS, S.A.  
6a. Ave. "A" 2-22, Zona 10  
Guatemala, C.A.

ELIAS V. SIUTTO  
Palacio Salvo  
Plaza Independencia 848 P. 4  
Montevideo, Uruguay

THOMAS, TAUNTON & CIA.  
Casilla 158-D  
Santiago, Chile

FOTO VELASCO  
Apartado Aereo 290  
Barranquilla, Colombia

# 1969-70 HI-LITES COIN MACHINE NEWS



**July**—The coinbiz fiscal year began with inflationary trends posing mounting problems for the industry. Increased operating costs necessitated higher play-pricing on machines and two for a quarter pricing gained in popularity as operators and location owners anxiously tried to gauge consumer reaction.

The entire vending industry mourned the June 27 passing of NAMA executive director Tom Hungerford . . . David Rosen inked a 10-20 year lease for the site of SEGA's new Tokyo plant . . . Sam Stern was appointed executive vice president of Bally Mfg. after retirement from Williams . . . Sam Daub's Eastern Pa. Amusement Machine Assn. completed its first U.S. Billiards-sanctioned eight-ball pool tourney . . . Millie McCarthy spoke out against Gov. Rockefeller's veto of the LaVerne Licensing Bill . . . The trade suffered the loss of MOA director A. M. Fleishman.

William Art Wood of World Wide Dist.'s sales staff celebrated his 40th year in coinbiz . . . Japan's royal family awarded a plaque to SEGA for its ambitious export program.

Interstate United Corp. added to its music/games holdings by acquiring the extensive route of B&B Vending and Music of Dallas . . . George Woolridge of Blackhawk Music was elected ICMOA prexy . . . Rowe appointed Harold Handkins as field sales manager and Dan Denman as marketing planning manager . . . Sugerman Intl. opened its Buenos Aires branch office . . . The break-in problem continued unrelieved in New York City and in other big city locations.

**August**—Within three days, Bally Mfg. announced its planned acquisition of both Midway Mfg. and the Lenc-Smith Co . . . Jerry Harris, Virginia sales rep for General Vending Sales, suffered a fatal stroke . . . John Bilotta, JAYBEE Records prexy, announced the release of Don Cornell's "The Lonely One," a jukebox-styled stereo single.

Harry Jacobs Jr., founder and president of United, Inc. died suddenly of a heart attack July 23 . . . Sol Lipkin, American Shuffleboard sales director, began a campaign to bring a stronger marketing emphasis behind his firm's non-coin products at the coin-op

equipment distributor-dealer level . . . Dime-n-Leagues completed its 1969 Grand National Tourney in bowling and pool divisions . . . Alvin D. Schaffer was elected vice president of manufacturing of Triangle Conduit & Cable Co., Inc., Rowe's parent company.

MOA Record Poll winners were Glen Campbell, best artist; "Harper Valley PTA" as best record, and MGM Records as record company best serving the needs of music operators . . . Drew Pearson, shortly before his death, accepted MOA's invitation as guest speaker on public relations for the Sept. convention.

Lance Hailstone was named Cointronics' marketing director . . . Fischer Mfg. opened new offices and showrooms in Skokie, Ill . . . Eurovend, newly-formed multi-national vending machine operation, acquired the backing of an international financial group . . . NAMA launched its 69-70 membership drive . . . Roy Waltemade was feted for his 35 years of service with Wurlitzer.

Jack Anderson was announced as Drew Pearson's stand-in at the MOA Exposition seminar on public relations when Pearson was confined to a hospital bed with a severe case of bronchial pneumonia . . . Mississippi locations felt the devastating onslaught of Hurricane Camille . . . John Trucano, president of Black Hills Novelty, was named to the South Dakota Industrial Development and Expansion Advisory Commission . . . Arnold Kaminkow announced his resignation as controller of General Vending Exchange, Inc . . . The West Virginia Music and Vending Assn. held its 15th annual convention in Charleston.

Last-minute details were attended to for the MOA Exposition as the entire trade anxiously prepared to converge on the Windy City . . . Louis Nicasro returned to the presidency of Seeburg . . . William Sabol was named general sales manager for National Rejectors Inc . . . Betson Enterprises/Eastern Novelty completed construction of an additional story, adding 8,000 square feet to the firm's North Bergen, N.J. headquarters.

Bally Mfg. signed an agreement to acquire its independently-owned Belgium distributor, Bally Continental Ltd . . . Mrs. Audrie May Granger, mother of MOA executive vice president Fred Granger, died August 30 at the age of 71 . . . Drew Pearson, originally scheduled to speak at the MOA Expo, died . . . James Sturdy was named director of engineering for National Rejectors, Inc . . . Wolf Lebovitz was re-elected president of the Shelby Cigarette Vendors Assn. . . Fred Blaess was appointed district sales manager for Fischer Mfg.

**September**—More than 2,000 MOA members and exhibitors attended the MOA Exposition held in Chicago September 5-7. Lou Ptacek was elected MOA president and outgoing prexy Howard Ellis received a plaque of appreciation. The only complaints were from

## for the play that pays every way! VALLEY COIN TABLES

Every feature on this line of Valley coin tables is designed for long service, long profit. Rounded rail edges, aluminum trim, laminated plastic on exposed surfaces, plus other asked-for features add up to durable, low maintenance operation. Tables are available in four sizes, all with one-piece slate playfields, reinforced cloth, 4-prong cues, regulation 2¼" balls. And 2¼" cue ball!

Turn small spaces into profit centers with coin operated Bumper Pool® tables — made only by Valley

**VALLEY POOL TABLES**  
RECREATION PRODUCTS GROUP  
DIVISION VICTOR COMPTOMETER CORPORATION  
333 Morton Street, Bay City, Michigan 48706

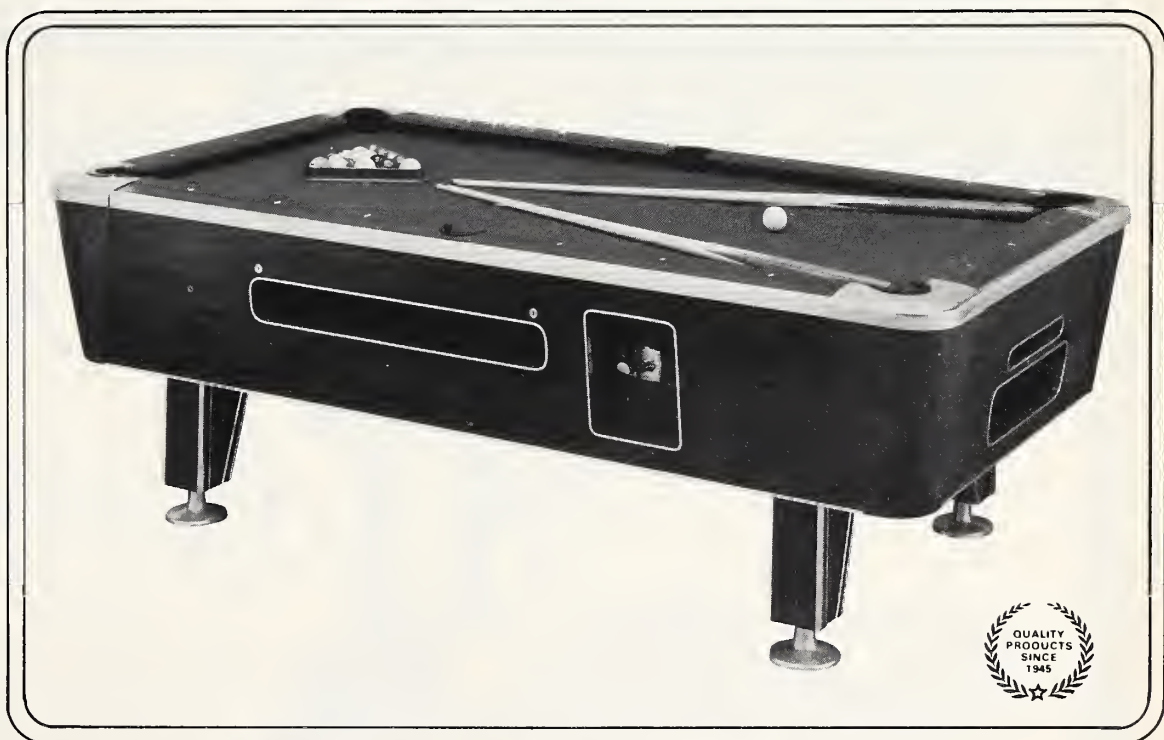

Exclusive—  
from Valley!

the ball that  
revolutionized  
coin-operated  
table play!



**Cat's  
eye  
CUE BALL**

It's regulation size for true action and accuracy! Locks in only when all numbered balls are played because it "sees in the dark" — rolls to a separate opening, ready for return to play. Only Valley has it . . . only Valley could!



## 1969-70 HI-LITES COIN MACHINE NEWS

those who objected to the post-Labor Day dates and the 1970 Expo date was consequently set for October . . . Edward Wurgler, former sales manager of the Wurlitzer phonograph division, died Sept. 7 at 78 . . . Allied Leisure moved to new manufacturing and office facilities in Hialeah, Fla . . . Harry Hurvich, borther and partner of Max Hurvich in Birmingham Vending Exchange, passed away Sept. 9.

Cameron Musical Industries Ltd. went public, offering 100,000 shares at three dollars a share . . . Arthur Siegel was named Seeburg senior vice president of finance . . . Dan Foster was named southern area sales manager for Canteen Corp . . . Thurman Greis was promoted to manager of quality assurance for National Rejectors Inc

the  GENERAL

LOOK to   for LEADERSHIP

One of America's oldest and largest coin machine distributors.

Established 1925 — over 46 years of superior service.

Franchised Factory Distributors in Md. — D.C. — Va. for:

NUTTING ASSOC. — COINTRONICS — ROCK-OLA

GOTTLIEB — FISCHER — CHICAGO COIN

and Other Leading Manufacturers

We export every type of reconditioned equipment  
anywhere in the World from the Port of Baltimore

### General Vending Sales Corp.

245 W. Biddle St.

Phones—(Area Code 301) 837-4119

Baltimore, Md.-21201

Cable Address—GENVEND

. . . Jack Romero was appointed Los Angeles district general manager of the Western Division of the Business and Industry Group of Interstate United Corp . . . James Trierwiler was tabbed as district manager of vending services for the Tacoma vending operation of Canteen Corp.

The eighth annual Japan Coin Machine Show was held in the Osaka Municipal Exhibition Hall for four days starting Sept. 18 . . . Representatives from all principal nations that manufacture amusement and music equipment gathered in West Berlin Sept. 16-19 for that city's first International Coin Machine Exhibition . . . Robert Mullins was appointed sales amanger of the Business and Industry Group of Interstate United Corp . . . Seth White was named district manager of vending services for the Charlotte operation of the Canteen Corp.

**October**—A State of Israel Bonds dinner honoring Philadelphia music and games operator Al Rodstein was scheduled for Oct. 26

. . . National Shuffleboard and Billiard Co. opened its new, multi-million dollar production and administration center in Green Brook, NJ . . . Dave Ralstin was named marketing director of Nutting's amusement machine line . . . Jerome Marcus was elected vice president and general manager of Victor Products Corp. of Hagerstown, Md . . . Portale Automatic Sales announced the appointment of Jim Wilkins as director of sales for the Southern California, Nevada and Arizona territories . . . Wendell Kilpatrick was named vice president and general manager of Universal Metal Products/Glasco . . . More than 400 operators, their wives, guests and members of allied industries gathered in Spring Glen, N.Y. for the anniversary convention of MONY, the Westchester Operators Guild and N.Y. State Operators Guild . . . National Rejectors, Inc. appointed Joseph Dalton director of manufacturing.

Bally Mfg. announced the consummation of its third acquisition in two months, the Midway Mfg. Co. which had annual sales of \$4 million . . . Julius Sturm announced his resignation as executive director of the Florida Amusement and Music Assn. after three and a half years of service . . . The fruit machine controversy in England continued to rage as more pressure was brought on brewers to permit licences to negotiate for and install fruit machines of their own choosing and many publicans objected to the dictation of terms by brewers.

The 23rd annual NAMA Convention-Exhibition in New Orleans was attended by more than 6,800 people. G. R. Schreiber, former editor and publisher of Vend Magazine, was named NAMA chief executive, succeeding the late Tom Hungerford . . . The South Carolina Coin

# EASTERN NOVELTY

is

*"the  
Manufacturers  
Choice!"*

There is a good reason why EASTERN supplies more pool table manufacturers with their accessories than any other firm. That reason is quality! The manufacturers want to deliver the best, and that means Eastern.

This unparalleled reputation for quality is what has made Eastern the largest pool table supply house catering to the Coin Machine Industry.

Matchless "Imperial" Cue Sticks

Our exclusive line of fine wood cues

- A tip and ferrule assembly that is virtually indestructible
- Genuine inlaid 4 prong, as well as simulated 4 prong cues
- Standard packing in a full variety of sizes and weights

Incomparable Imported "Aramith" Balls

- Manufactured in Belgium by Callenelle
- Unusually sturdy construction means lifetime usage
- Extraordinary clarity of ball numbers

We also feature a complete line of high quality cloths and slates.

Our complete catalogue (available upon request) shows the extraordinarily wide range of accessories we supply.

COMPLETE SATISFACTION  
Guaranteed

### Eastern Novelty Distributors, Inc.

Member BBIA

MAIN OFFICE: 3726 Tonnele Avenue (Routes #1 & #9)  
North Bergen, New Jersey  
(201) UN4-2424

WEST COAST OFFICE: 2939 East 11th Street  
Los Angeles, California  
(213) 269-5979

## 1969-70 HI-LITES COIN MACHINE NEWS



Operators Assn. held their fall meeting in Greenville . . . Bally Mfg. announced the completion of the 21,600 square-foot addition to its Dublin, Ireland plant . . . The Dime-n-Leagues eight-ball tournament got underway in 13 Virginia taverns . . . National Rejectors announced plans to locate its world headquarters in Hot Springs, Arkansas . . . Jim Tolisano of the Treasure Island Fun Center suffered a heart attack.

**November**—MOA group insurance trustees met to shape a new insurance plan . . . John Retting was named national sales manager for Airtown Records' single and little LP products.

The televised eight-ball tournament organized by South Dakota operators John Trucano and Buzz Oglemiller drew great response after KOTA-TV coverage . . . Harry Horne, well-known and well-liked New York City route collector died Nov. 3 at age 58 . . . Carl Novy was appointed sales manager of All-Tech Industries . . . Fischer Mfg. named Don Lee southwestern sales rep . . . James "Pie" Haley, one of the first midstate New York operators, passed away Nov. 1. Paul Rechtschafer, president of Capital Vending Services, was found dead in his car Nov. 3.

Bally Mfg. signed a contract proposal to acquire controlling interest in Automatiport, one of Sweden's largest distributors of music and games equipment . . . Mrs. Millie McCarthy was re-elected president of the N.Y. State Coin Machine Assn. at its annual meeting . . . Henry Leyser, prexy of California based ACA Sales and Service, announced appointment of Mickey Greenman as national sales chief for Prestige 160 and Consul 120, German-made jukeboxes.

Gene Wagner resigned as Nutting's marketing director . . . Harold G. Maerten retired after completing his 50th year with Wurlitzer . . . The industry was saddened by the passing of Les Montooth's wife Marge on Nov. 19 in Peoria.

K. A. O'Connor was elected president of the Music Operators of Virginia at its annual convention . . . New Jersey and Connecticut operators celebrated the 38th anniversary of Betson Enterprises . . . Mort Secore, sales manager at Chicago Dynamic, was hospitalized after a mild heart attack . . . Fred Pliner was appointed field director of sales and service for Bally and Midway Mfg.

**December**—Karl Goetting was named to represent Chicago Coin as director of exports for Europe, Africa and the Near East . . . The International Outdoor Amusement Exposition-Amusement Parks annual convention was held at Chicago's Sherman House featuring 245 display booths that represented 135 exhibitors . . . The board of directors of the Florida Amusement and Music Assn. held its fall meeting in Tampa . . . U.S. Billiards-sponsored eight-ball tournament finals were held in Davenport, Iowa with \$5,000 distributed in prizes . . . The coinbiz annual Boys' Town of Italy, Inc. campaign was successfully concluded.

Bally's directors voted a 3-2 split of the corporation's common stock . . . Nearly 100 tradesters attended an open house reception at N.Y.C. Paramount's route headquarters to celebrate repairs completed after the building was gutted by a June fire . . . Phase II of MOA's public relations program swung into high gear . . . Fischer Mfg. appointed Ralph Thrasher as a representative in the southeastern territory.

Ward (Marty) Johnson was named Nutting's director of marketing . . . The Billiards Congress of America concluded its annual tournament in Las Vegas, which was won by Luther Lassiter.

Bob Nims, president of A.M.A. Distributors, Inc., flew a large group of his customers to Grand Bahama Island for a long weekend in the sun . . . Howard Reinhart, president of Billiard Research and Development announced plans for relocating his entire operation in Berkley, Mich . . . Jimmy Caras, five-time World's Pocket Billiard champion, gave an exhibition of his pool skills at World Wide's Chicago showroom, to promote the new Brunswick CB-7 table.

**January**—A formal ceremony was held to celebrate the completion of SEGA's new Tokyo plant . . . Rowe president Jack Harper announced a major "operator-oriented" realignment of the firm's distribution division, making Joe Barton responsible for all Rowe sales and distribution activities, Clint Shockey director of music and games sales and Arnold Cohen director of vending sales . . . The Commercial and Financial Chronicle ran a flattering feature story on the Bally Mfg. Corp . . . Gordon Patton was appointed national accounts manager for Rowe and Vince Francischetti was named national accounts service engineer . . . ARA Services announced the completion of plans to build a million dollar area headquarters building in Sharonville, Ohio.

Dave Rosen took over the operation of Allinger's Billiard Academy

# 5 for the MONEY

Forty years of design engineering and proven quality means \$\$\$ for you.



The Golden Eagle



THE ROYAL Imperial



THE CLASSIC



SHUFFLE 88



The ROYAL CUSHION

WRITE or CALL for free color brochures, specifications and prices on these five tables.

*American* SHUFFLEBOARD COMPANY

210 Paterson Plank Road  
Union City, New Jersey 07087  
(201) 665-6633

1423 South Western Avenue  
Los Angeles, California 90006  
(213) RE 3-3724

"Quality Products"  SINCE 1928

**Exclusive Distributors  
In The U.S.A. for the  
GARLANDO FOOTBALL**

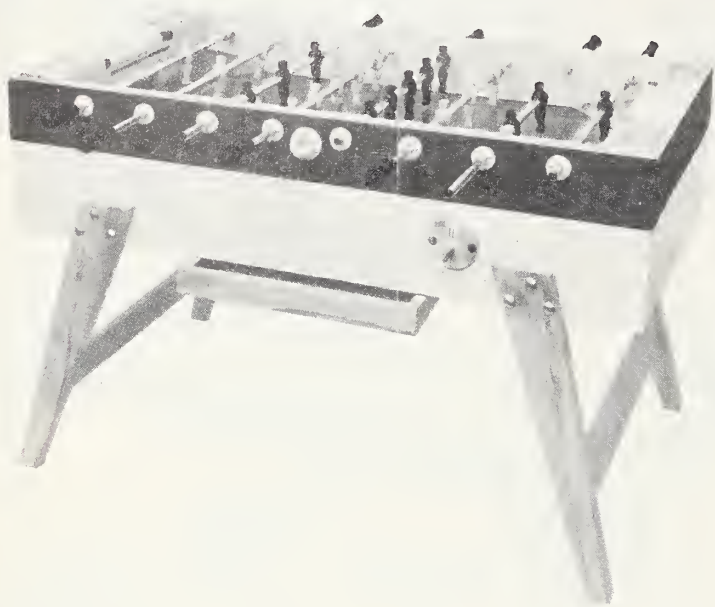

**Manufactured Specifically for Empire  
for distribution in the U.S.A.**



**EMPIRE INTERNATIONAL**

120 SOUTH SANGAMON STREET / CHICAGO, ILL 60607  
PHONE (312) 421-5200 • CABLE ADDRESS "EMCOMACH"

**Call or write  
for details**

**1969-70 HI-LITES  
COIN MACHINE  
NEWS**



on Market Street in Philadelphia with plans to set up an expansive home amusement center . . . The Irving Kaye Co. announced the appointment of World Wide Dist. as distributor of the Kaye line of coin-operated pool tables in the greater Chicago area . . . Bob Goad of the Game Sales Co. suffered a mild heart attack . . . MONY prexy Al Denver started his members on a vigorous mail petition campaign to combat the "Williams Amendment" to the Copyright Revision Bill.

Robert L. Lindelof of General Music Co. died on January 9 at the age of 65 . . . Al Miniaci of Paramount Industries, MONY's Ben Chifsky and Meyer Parkoff of Atlantic New York combined to lend a jukebox to the Riverdale Mental Health Clinic's annual Christmas party, one example of many such deeds across the country in the spirit of trade pr . . . Richard Stuke was appointed Fischer's director of marketing . . . Edouard Laniel was named chairman of the board of Laniel Canada, Inc. and Paul H. Fournier was appointed treasurer shortly after the death of Romeo Laniel, president and founder of the Canadian firm . . . Seeburg Corp. president Lou Nicastro was again elected president and chief executive officer of Seeburg's parent company, the Commonwealth United Corp . . . Joe Westerhaus Jr. of Royal Distributing donated the use of a phonograph to the Salvation Army Christmas drive in downtown Cincinnati . . . Murrey & Sons of Los Angeles instituted a sales promotion campaign to bring the pool table factory to the forefront of national trade attention as prexy Gordon Murrey set out to establish territorial distributors from coast to coast . . . H. Hayashi of Osaka's Matsushita Electric Trading Co. visited Wurlitzer of Los Angeles.

Jack Prokof, director of domestic military sales for Philip Morris, U.S.A., retired after 33 years with the company . . . NASA's Apollo 11 mission sparked the production of several moon mission games by leading amusement machine manufacturers . . . Seventeen service technicians attended two Wurlitzer service schools held at Bilotta Enterprises, Inc. in Newark, N.Y.

The largest attendance of foreign coin machine dealers and factory representatives on record joined their British trade colleagues Jan. 20-22 at the 1970 Amusement Trades Exhibition . . . Dick Gilger was named sales manager of the Shaffer Distributing Co.'s game division . . . Stanley Kluba, shop man at Marvel Mfg. Co. for 20 years, died of a heart attack on Jan. 26.

**STRUVE  
DISTRIBUTING**



1403 West Pico Blvd.  
Los Angeles, Calif.  
(213) 748-8641

1911 E. McDowell  
Phoenix, Arizona  
(602) 258-7925

50 Rio Grande  
Denver, Colorado  
(303) 222-9758



Exclusive Distributors for:

**SEEBURG • WILLIAMS**

**UNITED • U.S. BILLIARDS**

We Maintain A  
Large Export Department  
Cable: KLEACOE



**New England's Most  
Prominent Distributor**

... with the most  
complete package in the  
music and games line.

Rowe MUSIC/VENDING  
Gottlieb • ChiCoin  
All-Tech • Valley  
U.S. Billiards



**EXPORTING**  
Music/Games/Vending  
**THRUOUT  
THE WORLD**



**TRIMOUNT**  
Automatic Sales Co.

888 Providence Hwy. Rear  
Dedham, Mass. 02026  
(617) 329-3456  
Cable: TRICOIN

**February**—MOA put its mailing campaign into high gear to supply members with the 1970 Membership Directory and "Jukebox Story" in condensed booklet form . . . The Kansas Amusement and Music Assn. in conjunction with the Kansas Tobacco and Candy Distributors and Vending Assn. sponsored a bill in the state senate that would make it a felony to break into any coin-operated machine . . . Jack Mitnick announced his resignation from Allied Leisure Industries . . . Op Jack Jeffreys received the "1969 Community Service Award" at presentation ceremonies at the Osceola, Iowa Country Club . . . Shareholders of Bally Mfg. Corp. approved a 3-2 split of the company's common stock . . . Pool table manufacturers showed their non-coin products at Chicago's National Sporting Goods Show . . . Pete Entringer announced the formation of P.E. Enterprises, based in St. Louis.

MOA announced its Group Life Insurance Plan for members . . . Maynard Hopkins was elected president of the Northwest Ohio Music Operators Assn . . . Ross Scheer was appointed director of marketing for Bally and Midway Mfg. Co . . . Clayton Ballard was named as Wurlitzer's manager of market research and sales training . . . Bill Adair was named president of the Chicago Division of the Seeburg Corp. of Delaware.

At a board of directors meeting, ICMOA adopted a resolution to combat the Williams amendment to the copyright revision bill pending before the Senate . . . Anthony "Bart" Bartholomew was named manager of the Wurlitzer Los Angeles factory branch . . . New York tradesters were grieved to learn of the death of Abe Lipsky, a 20-year distributing and jobber veteran, on Feb. 15 at the age of 57 . . . Larry Berke was named sales manager for Midway Mfg . . . Gene Lipkin was named national sales manager for Allied Leisure Industries . . . A. Bouchard was named assistant manager of Montreal's Alouette Amusement and Hector Levert was appointed as sales representative . . . About 40 operators and wives were on hand for the general membership meeting of COIN in Omaha.

Fischer Mfg. Co. named Arnold Pyle as a sales staffer, Cliff Thayer as northwest sales representative and former U.S. Woman's Billiard Champion Mrs. Dorothy Wise as advisory staff member . . . Amile Addy was appointed manager of Wurlitzer's San Francisco branch . . . The Dale Distributing Co. of Vancouver, B.C. was appointed Canadian distributor for Cointronics' moon mission game.

## 1969-70 HI-LITES COIN MACHINE NEWS



**March**—The coin machine industry was deluged with both positive and negative publicity as the Washington Star ran a complimentary feature story, "Gee, It's A Wurlitzer" and CBS' "Sixty Minutes" insinuated that the jukebox industry was infiltrated by organized crime . . . Bob Burris was named Columbus branch manager for the Royal Distributing Corp. and Ray Hetterscheidt was named his assistant . . . Fred Minter was appointed sales manager of Specialty Sales Corp . . . The Gulf Coast Distributing Co. of Houston opened a showroom in San Antonio.

Louis Gruber celebrated his 25th year as a member of the service staff at David Rosen, Inc . . . The Mike Munves Corp. quelled rumors of the firm's sale, announcing "business as usual." . . . Gene Conklin was promoted to credit and collection manager at the Wurlitzer home office and Ronald Pyszynski was named his assistant . . . Myron Sugarman Intl. was appointed by Phonographic Equipment Ltd. of England as exclusive importer and distributor of their games line in the U.S. and Canada . . . Richard Stewart, representative of Club Specialty Overseas, Inc., the world-wide sales agent for SEGA games, met with SEGA management at the Tokyo hq . . . The German coin industry, behind the initiative of Lars Skriver completed a successful fund-raising drive, proceeds of which went for the construction of a hospital swimming pool for disabled children . . . Robert Spies received his second consecutive Canteen Corp. "salesman of the year" award.

Installation of equipment was completed at Expo '70's "Gameland" tent where 370 imported and Japanese-made coin-operated machines were placed . . . Canteen Corp. completed installation of 340 vending machines for a northern California military exchange food vending accounts . . . The MOA board of directors meeting was held at the Mark Hopkins Hotel in San Francisco where an amendment to kill the Williams Amendment to the U.S. Senate's Copyright Revision Bill was drawn up for presentation to the Senate Judiciary Committee . . . Edgar Blankenbeckler was named vice

president of the coin-operated phonograph division of the Seeburg Corp.

Michael Beckett, operator and board member of Mecca Ltd., one of Europe's largest leisure conglomerates, completed a five-day whirlwind tour of the US . . . Joseph Lally was elected vice president of engineering at the Bally Mfg. Corp . . . Automatic Products announced the development of its new line of 72 inch vending machines.

**April**—Germany's ZOA, comprising 10 regional coin machine associations, held its annual meeting, attended by 2,400 operators . . . The opening of the Japan World Exposition was formally held before Japan's imperial family and dignitaries from the 77 participating countries . . . David Hankin of Australia's A. Hankin & Co., completed a round-the-world business trip . . . Officers were elected by vending operators of Mississippi and Alabama at the first joint meeting of the associations in Biloxi, Miss . . . The Ninth Northern Amusement Equipment and Coin-Operated Machine Exhibition was held during February in Blackpool, England . . . Richard Oliver was named as Fischer's director of marketing for several southern and southwestern states . . . Delmar DeHaven, owner of DeHaven Vending, died at the age of 52 after a year's illness.

Betson Enterprises received the Automatic Products line of cigarette and snack venders for distribution in New York City, Westchester and two Long Island counties . . . Vic Haim, president of R. H. Belam Co., Inc., completed a sales trip during which he visited six Asian countries . . . The Jacksonville branch of Eli Ross Distributors, Inc. of Miami moved into new, expanded quarters . . . The Manistee, Mich. operators group completed its eighth annual coin-operated bowling tournament.

Representatives of music and amusement machine factories, scheduled to exhibit their products at the 1970 MOA Expo, met in Chicago with MOA executives to select individual exhibit space and air suggestions to increase attendance . . . Mecca Ltd. of London acquired 40,000 shares of Cameron Musical Industries' common stock at three dollars a share . . . The New York State Operators Guild completed its third annual eight-ball tournament.

Stanley Grajek was named Wurlitzer's director of phonograph engineering . . . A group of Massachusetts operators, under the leadership of Russ Mawdsley, intensified efforts to reactivate the Massachusetts Coin Machine Assn . . . Kansas State Bill 512, providing that any breakin of a coin operated machine would be regarded as a Class A misdemeanor, was passed and signed into law

# 2 FOR THE MONEY...

## PROVEN PROFIT PRODUCERS

Increase your profits with the All-Tech Line of coin-operated Pool Tables and Kiddie Rides—the line that set the industry standards of maintenance-free operation.



For Complete Information, contact:

**ALL-TECH INDUSTRIES, INC.**  
P.O. Box 4850, Miami Lakes, Fla. 33014

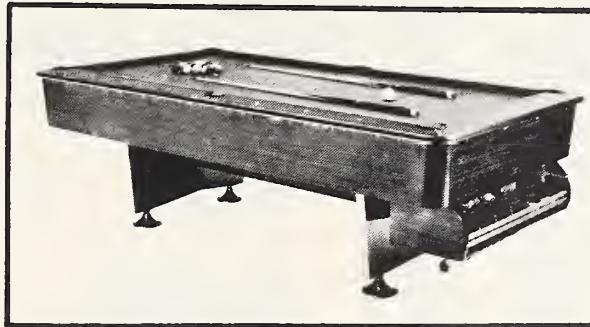

**DIPLOMAT POOL TABLES**  
The only tables that can be recovered in the field, without removing the slate . . . in a minimum of time.

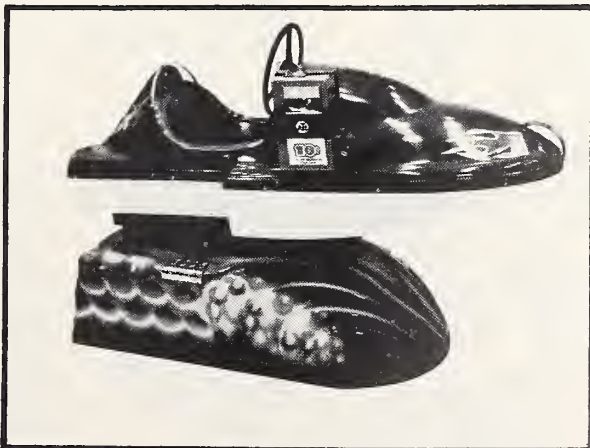

**HYDROJET RACER**  
The newest of our 'market-proven' Kiddie Rides. The top maintenance-free money makers in their class.



## 1969-70 HI-LITES COIN MACHINE NEWS

... Jack Beresin, coin-machine veteran, was honored by the Pop Warner Little Scholars for his long-time service to youth ... Many MOA members signed up for a new MOA group life insurance plan.

Meyer Parkoff, president of the Atlantic New York Corp., was honored by Congregation Beth Shalom of Lawrence, N.Y. for his vigorous efforts on behalf of the United Jewish Appeal ... The Music and Vending Assn. of South Dakota completed its third annual state eight-ball tournament in Pierre with 64 locations participating in four divisions.

**May**—Coin Controls Ltd. of London appointed Mar-Matic Sales, Inc. of Baltimore as its exclusive coin retractor representative in the U.S. and Canada ... Patent suit between Seeburg Corp. and NSM, manufacturers of Prestige 160 and Consul 120 jukeboxes settled, as two imported boxes become first foreign music machines to make major inroads on American market under sales leadership of Mickey Greenman, former head of Color Sonics, audio-visual combi-juke.

An Elizabeth, N.J. city council vote on a highly restrictive proposed ordinance regulating the licensing and sale of coin-operated phonographs and amusement machines, originally scheduled to be taken by May 6, was postponed until May 28 ... The Northern New York State Operators Guild held its second annual eight-ball tournament in Lake Placid ... Some 40 representatives of vending machine manufacturing companies participated in a meeting called by NAMA to be briefed and to exchange views on industry problems ... Three 1970 Wurlitzer Foundation scholarships were awarded to children of employees at the North Tonawanda headquarters ... The Seeburg Corp. of Delaware signed a 10-year licensing and trademark agreement with the Fuji Electric Co. of Japan to produce and distribute Seeburg-designed coffee and soft drink vending equipment for Japan and seven other Far East countries.

Jim Tolisano stepped down as president of the Florida Amuse-

ment and Music Assn. during a joint FAMA-Florida Automatic Merchandising Council convention held in Miami ... Russell Dougherty, owner of Rapids Coin Machine Service, Rapids, Wisc., announced his candidacy for the Republican nomination for state representative ... The federal Coinage Commission approved a Senate plan to mint 150 million silver dollars.

Jack Gordon conducted a coinbiz "happening" in New York where he presented the "Cameron" coin-op phonograph and discussed the "leisure decade" of the '70's and its implications for music operators ... AMIRO s/a of Geneva was appointed exclusive distributor in Switzerland for the entire line of Chicoin-manufactured equipment ... Jerry Janda, president of the New-Way Sales Co. of Toronto completed a two-week trip to Japan ... Tommy Wills, former head of Airtown Records, announced the formation of Juke Record Co., Inc., based in Richmond, Indiana.

**June**—Harry Martin was elected president of Rowe and was also elected to the board of directors of Triangle Industries, Rowe's parent company ... Edward Simmons was elected president of Triangle ... The South Dakota Music and Vending Assn. held its annual meeting, electing Buzz Oligmiller president ... Bally Mfg. Corp. released its 1969 annual report and first quarterly report for 1970, listing increases in all major financial categories compared with figures of a year ago.

The LaVerne Licensing Bill, a measure that would license amusement machine operators in the state of New York on a bi-annual basis, was vetoed by Gov. Rockefeller for at least the fifth time ... Walt Waldman of S.L. Stiebel in Louisville, completed an Asian business trip ... Empire Dist. of Chicago set up a display of coin-operated machines in the lobby of the new University Bank in Green Bay ... Controversy was aroused in Florida over the proposal of a bill to legalize bingo machines in that state.

UMC Industries of St. Louis created an international company, NRI Intl., to assume management responsibilities for the worldwide manufacture and sale of coin and currency handling equipment for the automatic merchandising industry ... Rock-Ola appointed Quentin Ruchte to the newly formed position of director of technical services for the firm's music and vending divisions ... James Bowling, vice president of Philip Morris Inc. attacked the critics of the tobacco industry during a speech to the Missouri Assn. of Candy and Tobacco Distributors ... Coin Operated Industries of Nebraska got its organizing drive into high gear with ambitious plans for its Omaha meeting.

# ARCADE WINNERS!



## Photomatic

Automatic portraits delivered by a trouble free mechanism. Guaranteed long life and high profits.

*a Sure Winner!*

## Plasti-Matic

LOOK IT'S EASY!  
SEAL IN PLASTIC

New low,  
low prices.



Both full size  
and counter-top  
models available.

*a Sure Winner!*

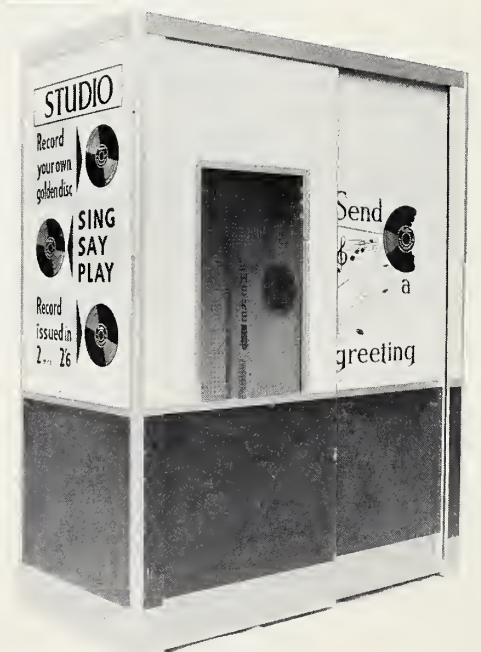

## Voice-O-Graph

HIGH QUALITY, distortion free reproduction, on long-lasting 6" all plastic discs.

*a Sure Winner!*



DON'T DELAY! Call or Write

**TODAY!**

INTERNATIONAL MUTOSCOPE CORPORATION

11-12 44th AVENUE • LONG ISLAND CITY, NEW YORK 11101 • (212) STIllwell 4-3800



# COIN-OPERATED PHONOGRAPHS (ACTIVELY TRADED)

## ROCK-OLA

Mfg. Corp.

800 N. Kedzie Ave.  
Chicago, Ill.  
1961-1970

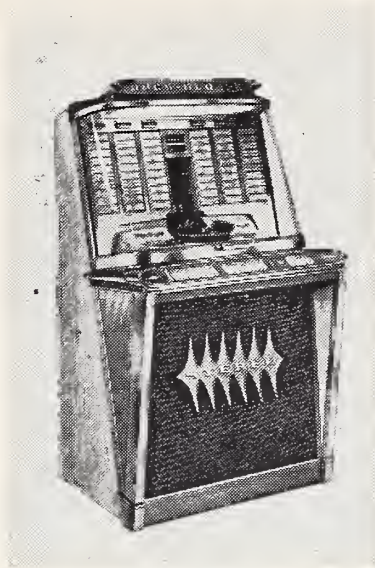

Rock-Ola 1495  
(1961-200 Sel.)  
Model 1488-120 Sel.

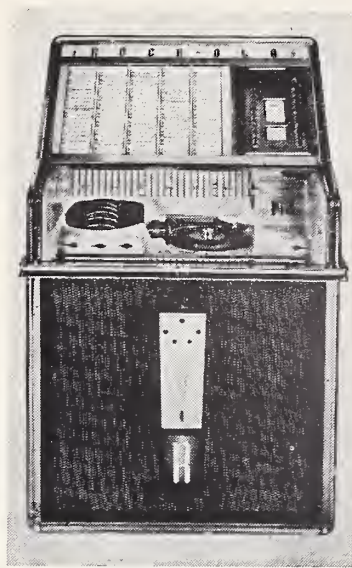

Rock-Ola 1493  
(1962 Princess-100 Sel.)  
45-33 rpm, and Wall Mdl. Avail.



Rock-Ola 1497  
(1962 Empress-200 Sel. 45-33)  
Model 1496-120 Sel.

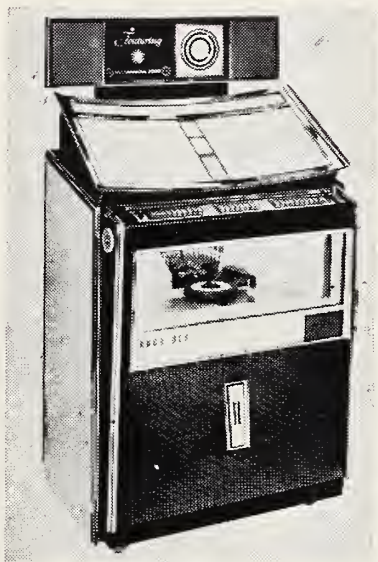

Rock-Ola 408  
(1963 Rhapsody-160 Sel.)  
Capri-404-100 Sel., 45-33 rpm

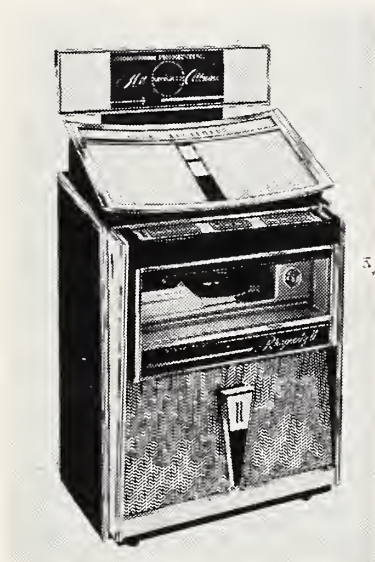

Rock-Ola 418 SA  
(1964 Rhapsody II-160 Sel.)  
Capri-414-100 Sel., 45-33 rpm

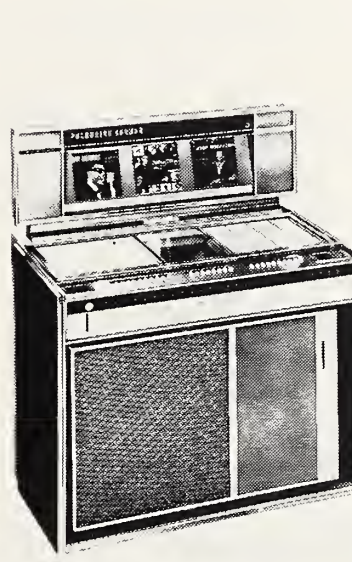

Rock-Ola 425  
(1964 Grand Prix 160-Sel.)  
33-45 rpm



Rock-Ola 426  
(1965 Grand Prix II 160-Sel.)  
St-Mon. 33-45 rpm

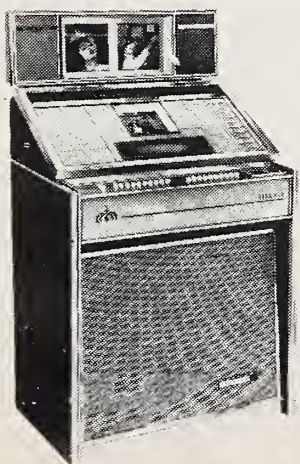

Rock-Ola 424  
(1964 Princess Royal St-Mon)  
100-Sel. 33-45-7" LP Intermix

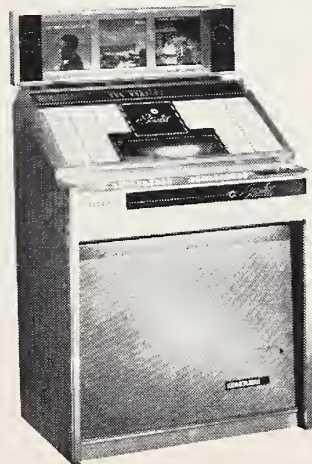

Rock-Ola 429  
(1965 Starlet St-Mon)  
100-Sel. 33-45-7" LP

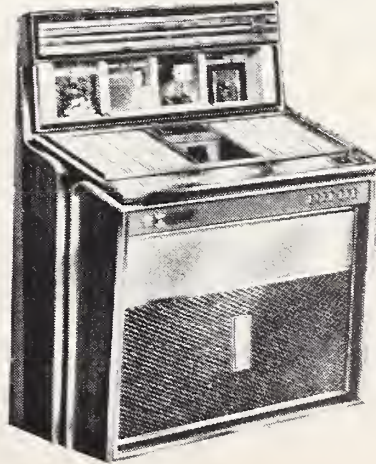

Rock-Ola 433  
(1966 GP/Imperial St-Mon)  
160 Sel. 33-45 rpm



Rock-Ola 431  
(1966/67 Coronado St-Mon)  
100 Sel. 33-45 rpm



Rock-Ola 432  
(1966/67 GP/160 St—Mon)  
160 Sel. 33—45 rpm

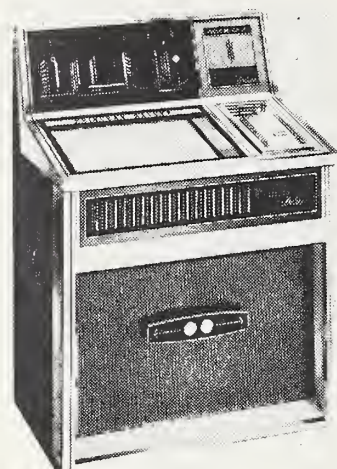

Rock-Ola 435  
(1967-68 Princess Deluxe Stereo)  
100 Sel. 33—45 rpm

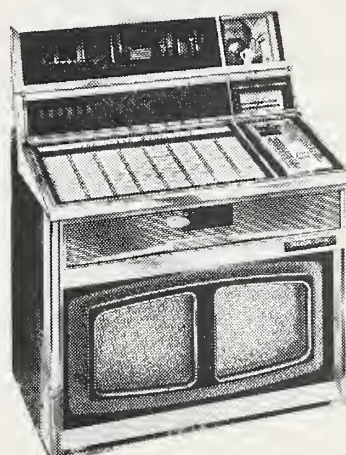

Rock-Ola 437  
(1967-68 Ultra Stereo)  
160 Sel. 33—45 rpm

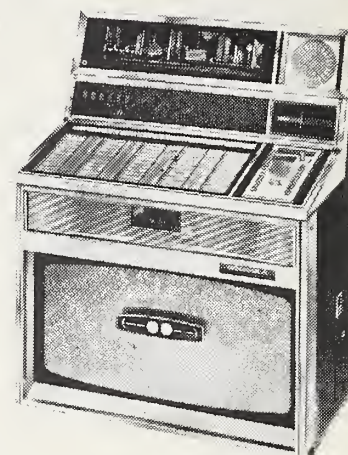

Rock-Ola Centura 436  
(1967-68 Centura)  
100 Sel. 33—45 rpm

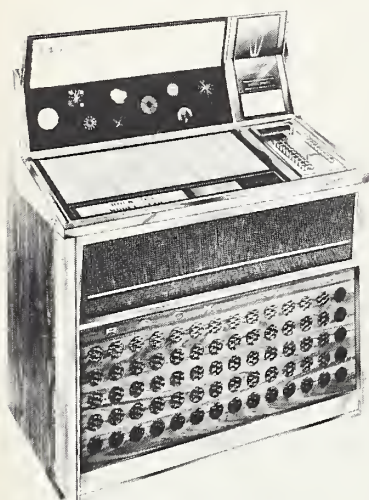

Rock-Ola Model 440  
(1968-1969)  
160—Sel. St—Mon

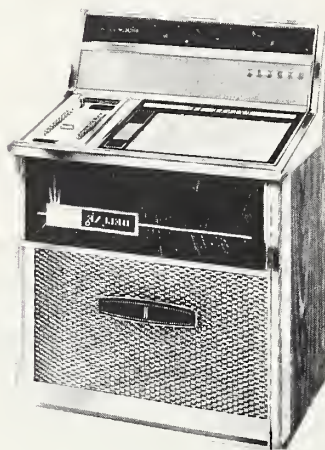

Rock-Ola Model 441  
(1968-1969)  
100—Sel. St—Mon

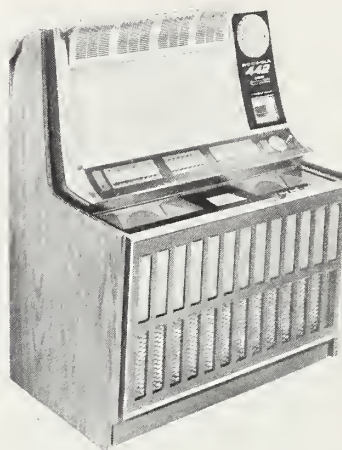

Rock-Ola Model 442  
(1969-1970)  
160-200 Sel. 33-45 rpm stereo

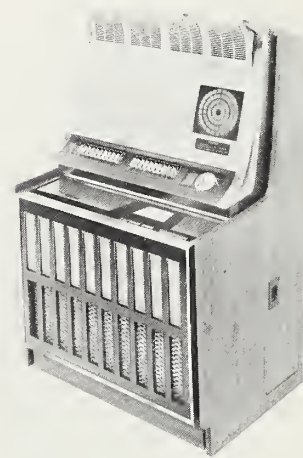

Rock-Ola Model 443  
(1970)  
100 Sel. 33-45 rpm stereo

**ROWE**  
**INTERNATIONAL**  
(Div. of Triangle Industries, Inc.)  
**Troy Hills Road**  
**Whippany, N.J.**  
**1960—1970**

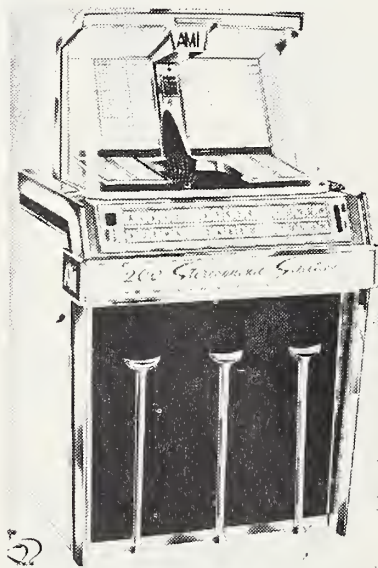

Rowe "K"  
(1960 200, 120 or 100 Sel.)

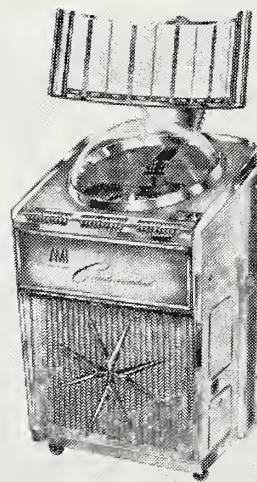

Rowe "Continental 200"  
(1960 200—Sel. Lyric 100—Sel.)

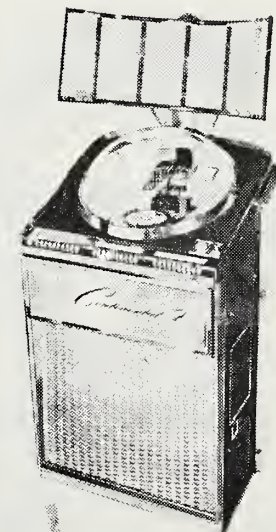

Rowe "Continental 2"  
(1961 200 or 100—Sel. 45—33)



# the ultimate phonograph

The elegant look of tomorrow is here today in the image of the all new Rock-Ola/442 phonograph. Years ahead in design. Dollars ahead in performance.

Put this exciting new idea in phonographs in any location, and what happens is a crowd. Every time. Small wonder! Brilliant color panels incased in polished chrome castings radiate the warm glow of this new kind of phonograph.

It's a big new sound in an all new package. Rakish lines of highly finished wood-grain Bombay Teak Conolite side panels sweep in graceful contour to accent the most plush decor.

Here's 160 selections of stereo-monaural excellence designed to capture the most elegant profit center. 33 $\frac{1}{3}$ , 45 RPM records or 7" LP albums in any sequence.

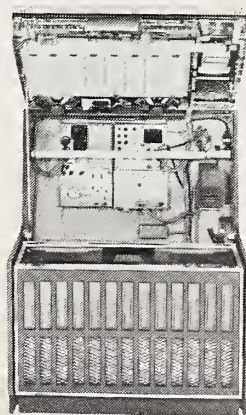

A dramatic new concept in operator features to give more take with less trouble . . . swing-out, lift-out components . . . integrated circuits . . . snap-out grill . . . stand-up programming and a full line of accessories. "Two Plays—Two Bits" standard.

## ROCK-OLA/442

"we want you to take it easy"

**Rock-Ola Manufacturing Corporation**  
800 North Kedzie Avenue  
Chicago, Illinois 60651



Rowe-AMI  
(1962-63 200, 160 or 100—Sel. 45—33)

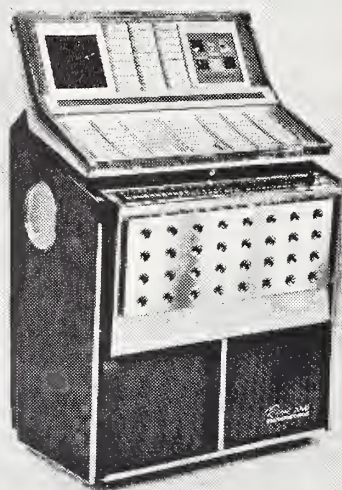

Rowe "Tropicana"  
(1963-64 200, 160 or 100—Sel. 45—33)

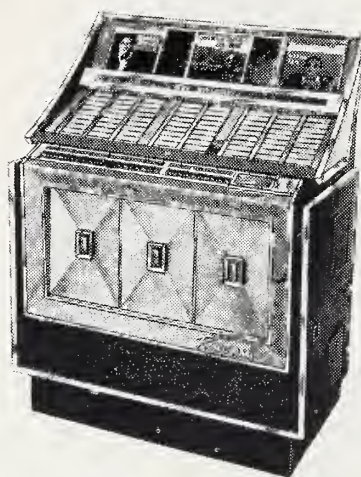

Rowe "Diplomat"  
(1965 200, 160 or 100—Sel. 45—33)



Rowe "Band Stand"  
(1966 Model JAO 200 Sel.)  
33—45 rpm



Rowe AMI MM-1  
(1966/67 100-160-200 Sel.)  
Optional dollar bill acceptor  
33—45 rpm

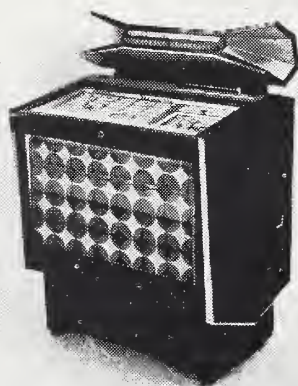

Rowe AMI Cadette  
(1967-68 Compact)  
100 Sel. 33—45 rpm

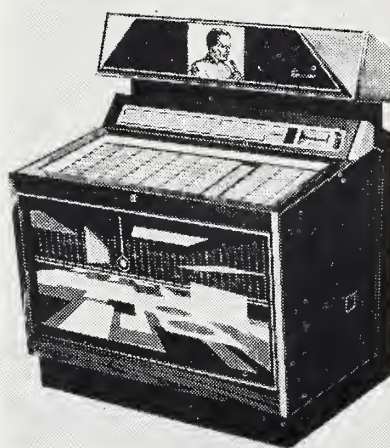

Rowe AMI MM 11  
(1967-68 Music Master)  
RoweVue Slide Projector  
200 Sel. 33—45 rpm Stereo

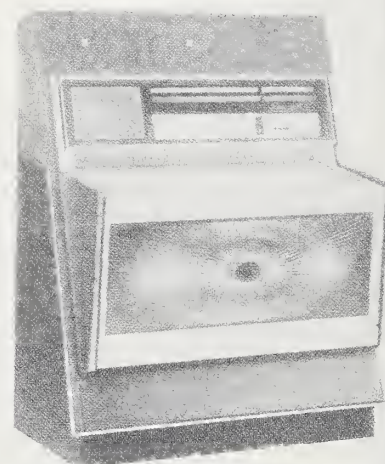

Rowe Music Miracle  
Model MM-3 (1969)  
200 Sel. (converts to 160 & 100)  
Stereo-Mono

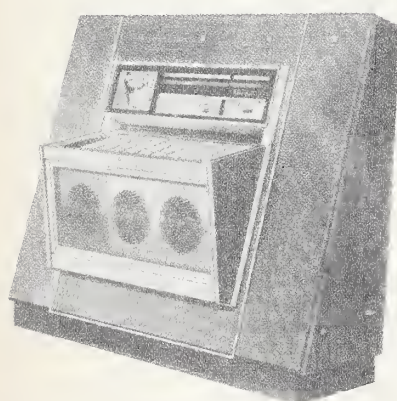

Rowe Music Miracle  
Model MM-3 (1969)  
Same as left but with  
Wall-of-Sound Speakers

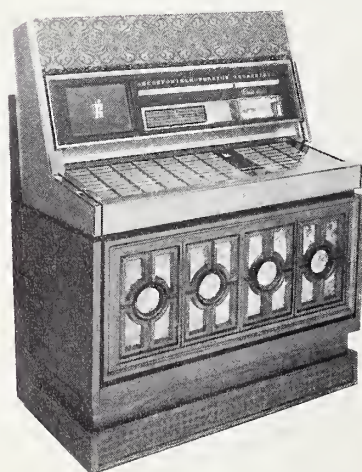

Rowe Trimount (MM4)  
(1969-1970)  
100-160-200 Sel. 33-45 rpm stereo

**SEEBURG**  
**SALES CORP.**  
**1500 N. Dayton**  
**Chicago, Ill.**  
**1960—1970**

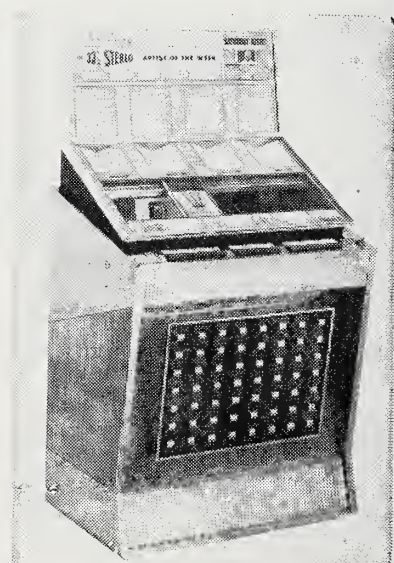

Seeburg "AQ160S"  
(1960—160 Sel. 45—33)



A NEW DIMENSION  
IN  
MUSIC.  
THEME AND VARIATIONS



SILVER CROWN GRILL



TRIPLE TRIM PANEL



ORANGE FANTASY PANEL



MEDITERRANEAN PANEL WITH FABRIC COWL GRILL



VINYL VEIL GRILL



BOXES 4 PANEL

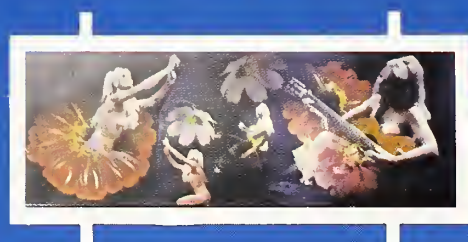

FLOWER FRIENDS PANEL

**THE TRIMOUNT BY ROWE AMI**

The theme is the Rowe basic machine. As dependable as ever. With complete front door servicing. Dry lubricants that last 5 years. Sintered gold electrical contact points that don't corrode, pit, or tarnish. And a 5-year warranty.

Our basic theme also includes these new features: an improved bass sound chamber. New Hybrid Solid State Tube amplifiers that use the best of two amplifying systems. (They can be visually "troubleshoot" on location.) And an animated display that will attract attention and stimulate play.

The variations are the grills and front panels pictured here. They can make the Rowe Trimount look like 15 different machines. And can be changed on location within 15 minutes.

If you want to see what a difference a panel makes, use the cut-outs on this page. And make your own music maker.

Then make sure you see a Rowe man about it. So we can make beautiful music together. Soon.

**Rowe international, inc.**

A SUBSIDIARY OF TRIANGLE INDUSTRIES, INC.  
75 TROY HILLS RD., WHIPPANY, N. J. 07981

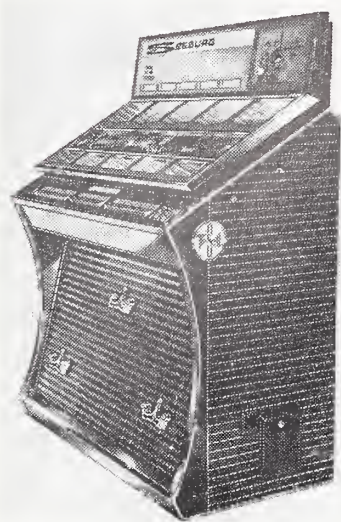

Seeburg "AY160S"  
(1961 160—Sel. 45—33)  
Model "AY100S" 100—Sel.

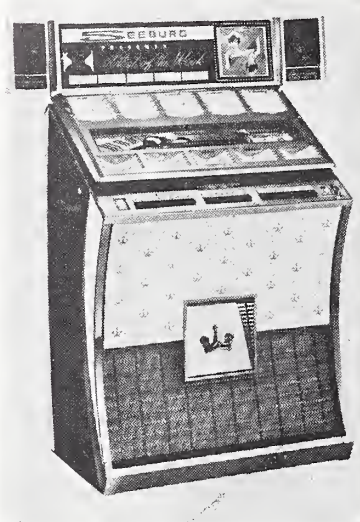

Seeburg "DS160"  
(1962 160—Sel. 45—33)  
Model "DS100" 100—Sel.

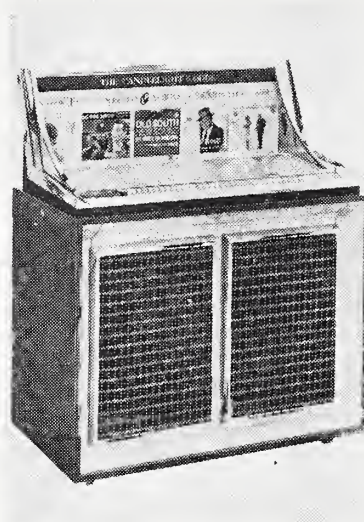

Seeburg LPC-1  
(1963-64 160—Sel. 45—33)

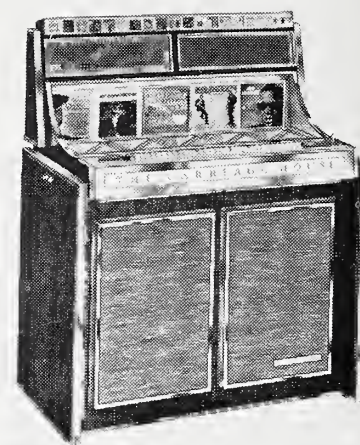

Seeburg LPC480  
45—33 rpm

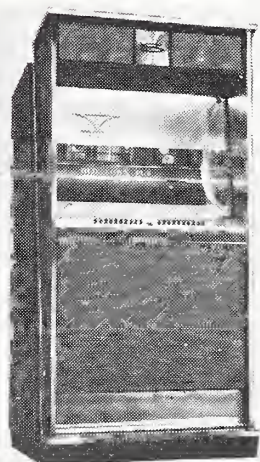

Seeburg "Mustang"  
(1965-1966 100—Sel. 45 rpm)

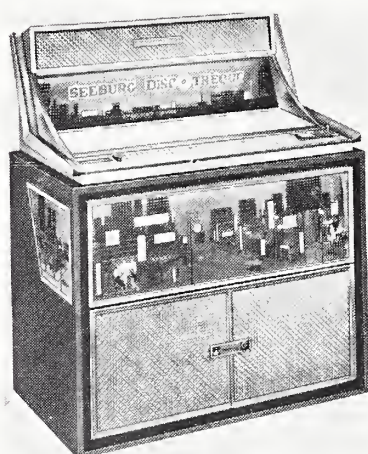

Seeburg "Electra"  
1965-66 160—Sel. 33—45 rpm)

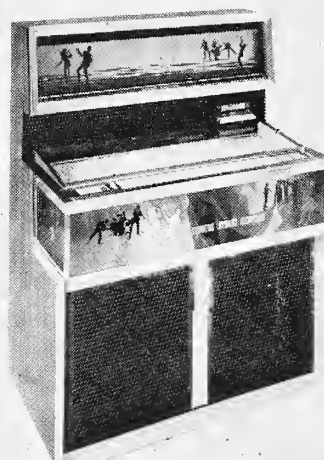

Seeburg Stereo Showcase  
(1966/67 160 Sel. St. Mon.)  
33—45 rpm  
optional dollar bill acceptor

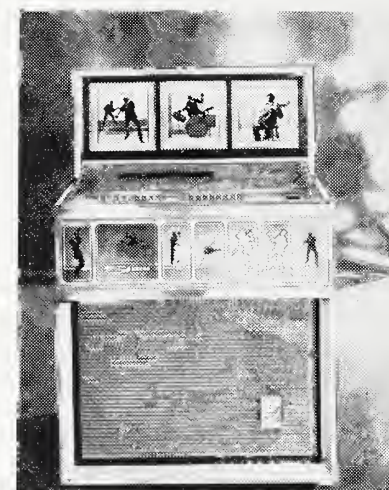

Seeburg Phono Jet  
1967-68 100 Sel. Stereo  
Compact 33-45 rpm

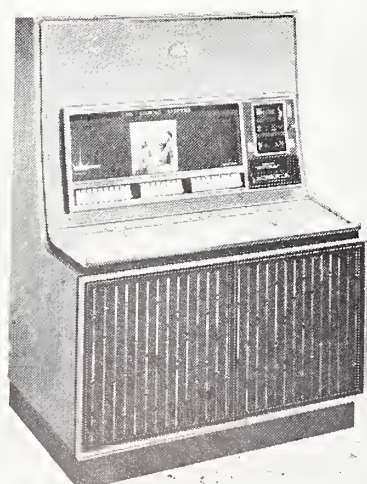

Seeburg Spectra  
1967-68 200 Sel. Stereo  
2 for .25 Pricing 33-45 rpm

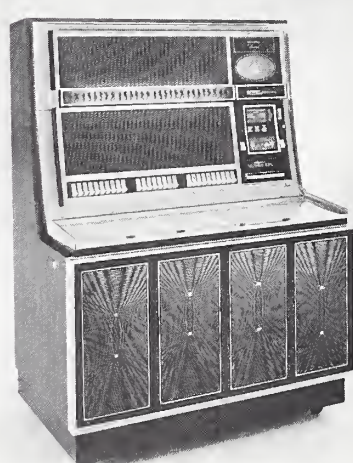

Seeburg Gem—160 Sel. Stereo  
Dollar Bill Special  
2-way cone & Horn speakers  
slide in slide out record mech  
rear access panel.



Seeburg Apollo  
(1969-1970)  
160-200 Sel. 33-45 rpm stereo

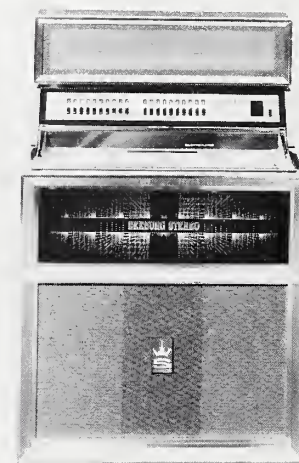

Seeburg Golden Jet  
(1969-1970)  
100 Sel. 33-45 rpm stereo

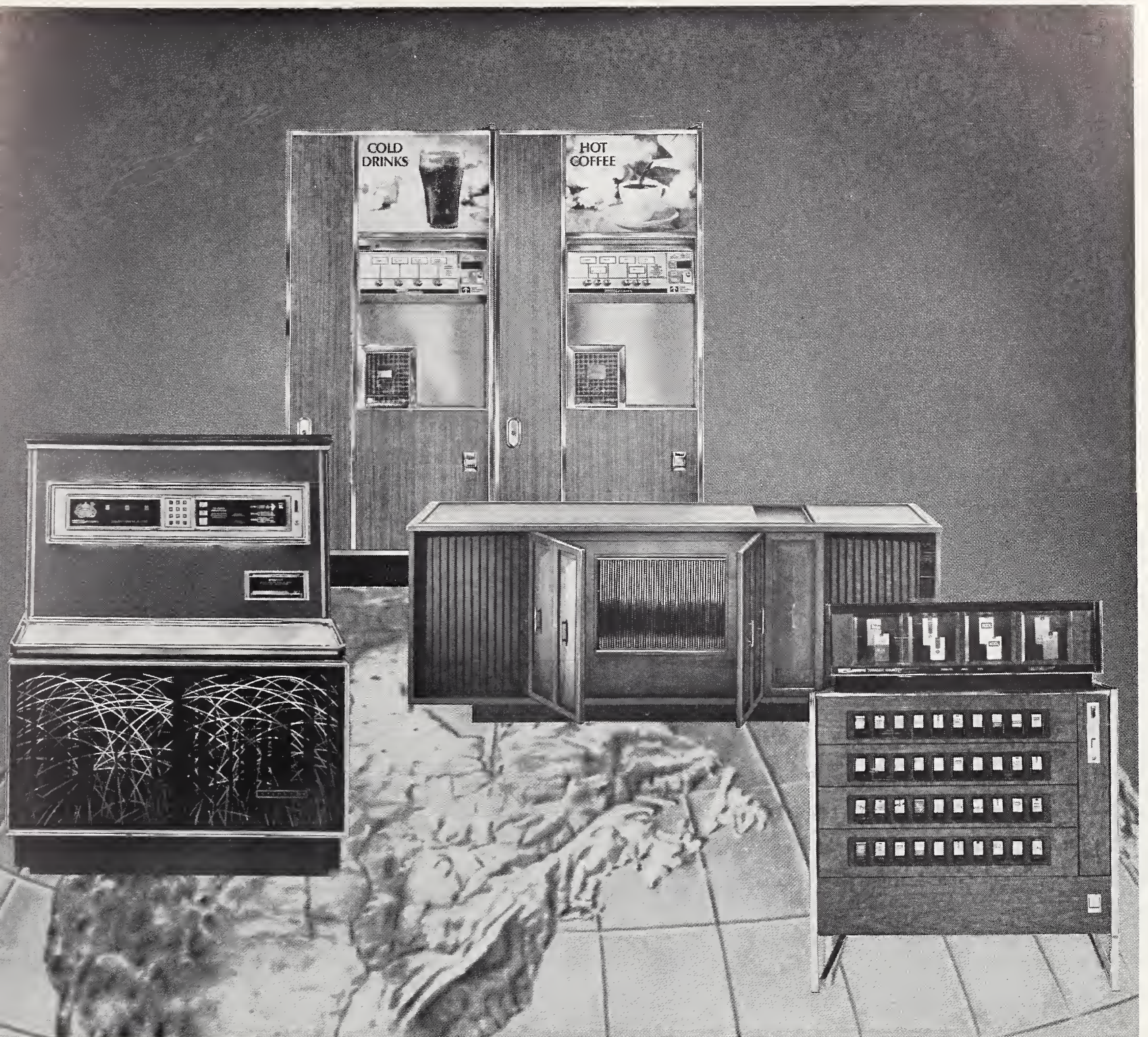

Nationwide; worldwide... Seeburg serves you!

Wherever you find coin-operated vending, you find Seeburg first with the best.

In coin-operated phonographs, Seeburg leads with profit-making features. The high-style contemporary look and the high-fidelity stereo sound of today's coin phonos are both Seeburg firsts.

In cigaret vending, the Seeburg Tobacco Counter has eliminated the awkward stooping and bending. Handsome new 1,056 pack machines offer as many as 40 brands at countertop level instead of knee level.

In beverage vending, the name Seeburg stands for progress and innovation. Seeburg designed and marketed the first cold-drink vender. Today Seeburg sophisticated hot and

cold venders are preferred the world over.

In home stereo, Seeburg is first with the exclusive new vertical record changing system that ends record handling, turning, and record damage. In background music, Seeburg is a leader in shaping attitudes with music specially paced to the work tempo. In pianos, organs and band instruments, Seeburg subsidiaries are world-renowned.

Wherever you work or play, nationwide or worldwide, Seeburg serves you . . . first with the best.

**SEEBURG**

THE SEEBURG CORPORATION, CHICAGO, ILLINOIS 60622

# COIN-OPERATED PHONOGRAPHS

**Wurlitzer**

**THE WURLITZER CO.  
N. TONAWANDA, N.Y.**

**1960-1970**

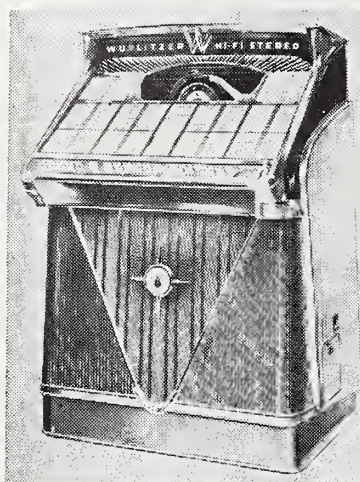

**Wurlitzer 2400**  
(1960 200-Selections)  
2404-104-Sel., 2410-100-Sel.

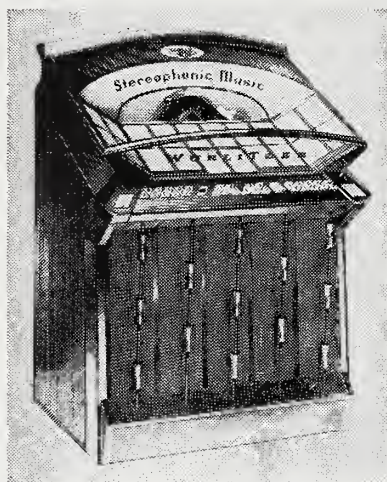

**Wurlitzer 2500S**  
(1961 200-Sel. 45-33 Avail.)  
2504-104-Sel., 2510-100-Sel.

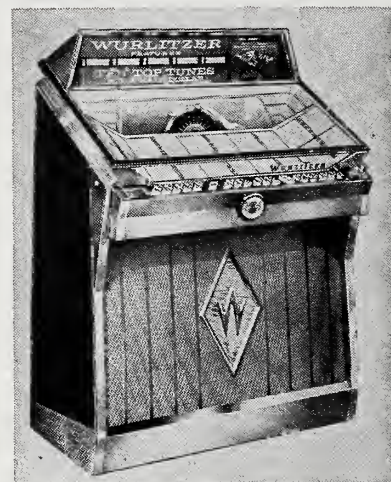

**Wurlitzer 2600**  
(1962 200-Sel. 45-33)  
Model 2610 100-Sel.



**Wurlitzer 2700**  
(1963 200-Sel. 45-33)  
Model 2710 100 Sel.

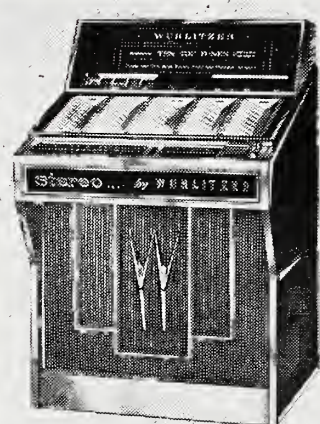

**Wurlitzer 2800**  
(1964 200-Sel. 45-33)  
Model 2810 100-Sel.



**Wurlitzer 2900**  
(1965 200-Sel. 45-33)  
Model 2910 100-Sel.



**Wurlitzer 3000**  
(1965-1966 200 Sel. w/Top Tunes  
and little LP albums)

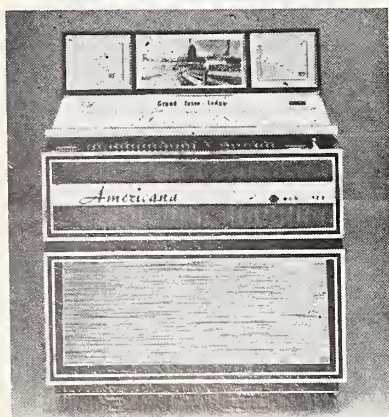

**Wurlitzer Americana 3100-3110**  
160-200 Sel. Models  
(1966/67 stereo-mono 33-45 rpm)  
optional dollar bill acceptor

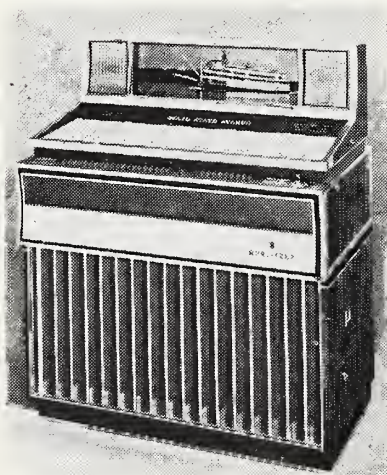

**Wurlitzer Americana 11**  
Model 3200 200 Selection  
33-45 rpm stereo



**Wurlitzer Americana 111**  
200 Sel., Stereo, Solid State Amplifier  
Play Selector Panel  
Dollar Bill Acceptor, Income Computer  
P.A. System, Playrak credit System  
LLP's



**Wurlitzer Statesman**  
(1969-70)  
100-160-200 Sel. 33-45 rpm stereo



# Just Like Having Two Juke Boxes in a Location



**Sure to  
multiply  
earnings from  
multi-room  
locations**

**Wurlitzer  
Satellite II**  
Another  
Wurlitzer  
Exclusive

Satellite II is the world's biggest wall box but it sits on the floor and stands way up in earnings.

Takes coins like a juke box. Selects like a juke box.

Blends beautifully into any decor. Offers 200 selections, can be set for any combination of coin play on its own Playrak, contains no play mechanism as music is played from its companion Wurlitzer Phonograph.

Never wears out. Never goes out of style. Never fails to pay its way in increased earnings. Never offered by anyone but WURLITZER!

See your Wurlitzer Distributor — FAST!

The Wurlitzer Company  
115 Years of Musical Experience  
North Tonawanda, N. Y. 14120

# COIN-OPERATED PHONOGRAPHS

N.S.M. GMBh (Bingen am Rhine, Germany)  
 Associated Coin Amusement Co. Oakland Cal.  
 (Exclusive Sales Representatives)

Cameron Musical Instruments

82 S. Bayles Avenue  
 Port Washington, N.Y. 11050

## N. S.M. Cameron



**CONSUL 130**  
 128 selections, 33-45 rpm, 30 watt amplifier; oak cabinet, furniture-like appearance.

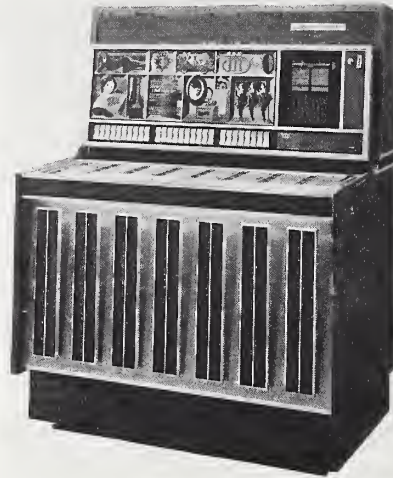

**PRESTIGE 160**  
 160 selections, 45-33 rpm, adjustable credit unit for pricing flexibility.

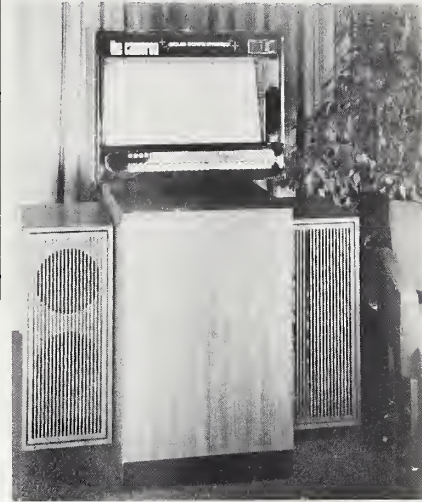

**THE CAMERON**  
 140 Selections, 33-45 rpm, components can be separated (for remote operation), kept intact for console appearance.

## REMOTE SELECTOR UNITS

Under current  
 production

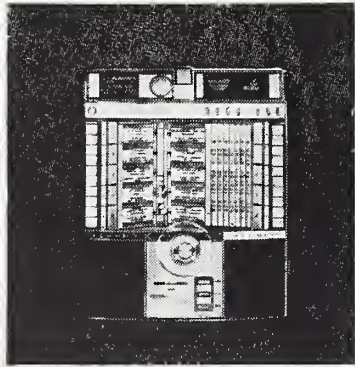

Rock-Ola Phonette  
 (Remote Wallbox 160 Sel. Twin st. speakers Model 503, Model 504 100 sel.)

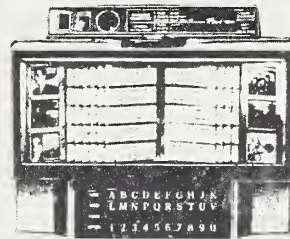

Rowe AMI Wall-Ette  
 (#WRA, WRB remote 200 Sel Push-button volume control, twin st. speakers)



Seeburg Consolette  
 (Remote, 160 Sel., Push-button volume control, Twin st. speakers)

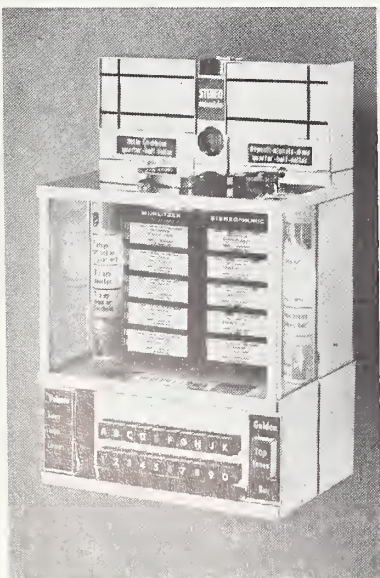

Wurlitzer Model 5220  
 (200 Sel. W/twin speakers, push-button volume control)



Wurlitzer Satellite II  
 (Model 5131, 100 Sel. Remote speaker console Model 5132, 200 Sel.)

Rowe AMI Phono Vue companion film projection unit. 20 sel., cartridge load. Super 8mm film.



## (The United Billiard's Address)

*Four years and seven months ago we brought forth in our industry a new company, conceived in the idea that a better product could be produced and dedicated to the proposition that all pool tables on the market are not equal.*

*Now we are engaged in a great competitive war, testing whether our products, or any other such products, can long endure.*

*We have met on this battlefield of competition and emerged, not only with a product that will long endure, but also emerge as the fastest growing company in our industry.*

*The industry will little note or long remember that it was not too long ago that we first started, but it will never forget the quality and workmanship of our product.*

*It is fitting and proper that we did this, but in a larger sense we cannot dedicate ourselves to the past. We must continue to research and develop our product to give birth to new ideas that shall present to the industry a product with the operator in mind. We shall dedicate ourselves to the principle that only a product that is conceived by the operator and for the operator will long endure.*



51 Progress Street, Union, N.J. 07083  
Phone: (201) 686-7030

## PINGAMES



BALLY

CHICOIN



Bally Bally Hoo 4 pl



Bally Bowl-O 1 pl



Bally Camelot 4 pl



Bally Galahad 2 pl



Bally Gator 4 pl



Bally Joust 2 pl



Bally King Tut 1 pl



Bally King Rex 1 pl



Bally On Beam 1 pl

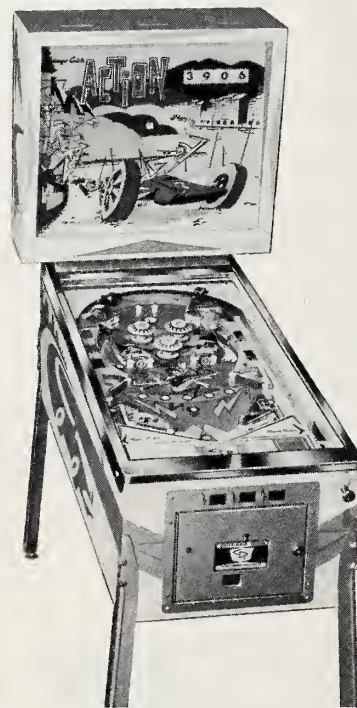



Chicoin Action 1 pl



Chicoin Astronaut 2 pl

# Great new Coin-Op Table in sizes you can live with!

Right! This year Murrey has expanded its popular 3M (Murrey Money Maker) Coin-Op Table line to include 3 basic models...tables that will fit almost any area's limitations. And, best of all, these quality slate tables are **tamper-proof** and **service free**. Check Murrey's prices and you'll buy Murrey...no matter where you are in the U. S. For the finest in Coin-op, regulation and home tables and equipment, write, wire or telephone Murrey today.   Murrey & Sons Company, 14150 South Figueroa Street, Los Angeles, Dept. C-6, California 90061 • Phone: (213) 323-1752

## TAMPER PROOF SERVICE FREE

### 3 POPULAR SIZES

#### Model 3M-1 Professional

4' x 8'  
Playing area 44" x 88"  
Overall Size 4' 8" x 8' 4"  
Quality 3/4" Slate

#### Model 3M-2 Popular Three-Quarter

4' x 8'  
Playing area 40" x 80"  
Overall Size 4' 4" x 7' 8"  
Quality 3/4" Slate

#### Model 3M-3 Space Saver Model

Playing area 36" x 72"  
Overall size 4' 1" x 7' 2"  
Quality 3/4" slate

- Live Rubber Cushions
- Fast Rebound Straight Line Rails
- Aluminum Pocket Castings
- Automatic Anti-cheat Mechanism
- Easy to See - Removable Ball Viewer
- Streamlined Fast Ball Return
- Coin Meter Standard Equipment
- Bum-Proof, Stain Resistant Simulated Wood Laminated Rails and Cabinet
- Professional Billiard Equipment
- Mar-Proof Metal Molding
- Separate Locked Cash Box
- Recessed Trouble-free Coin operating Mechanism
- Pro Nylon-Blend Billiard Cloth With Backing
- Not Necessary to Remove Slats for Recovering... 1 Man Job
- Adjustable Leg Levelers



## PINGAMES



CHICOIN  
GOTTLIEB  
WILLIAMS



Chicoin Moon Shot 4 pl

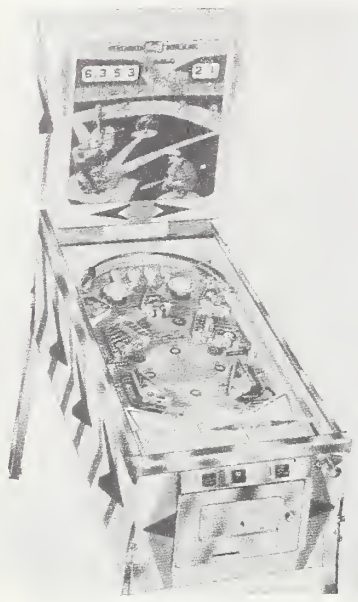

Gottlieb Baseball 1 pl

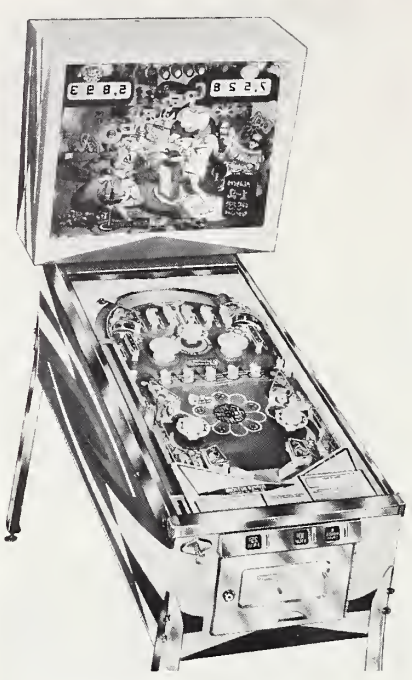

Gottlieb Crescendo 2 pl



Gottlieb Flip a Card 1 pl

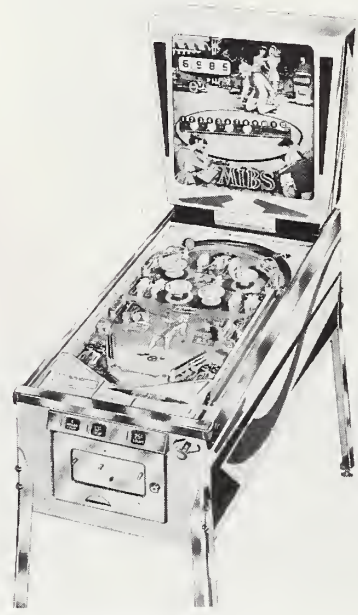

Gottlieb Mibs 1 pl



Gottlieb Mini Cycle 2 pl



Gottlieb Road Race 1 pl

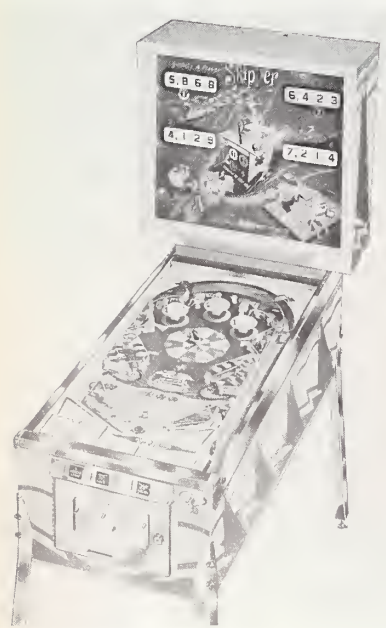

Gottlieb Skipper 4 pl



Gottlieb Wild Wild West 2 pl

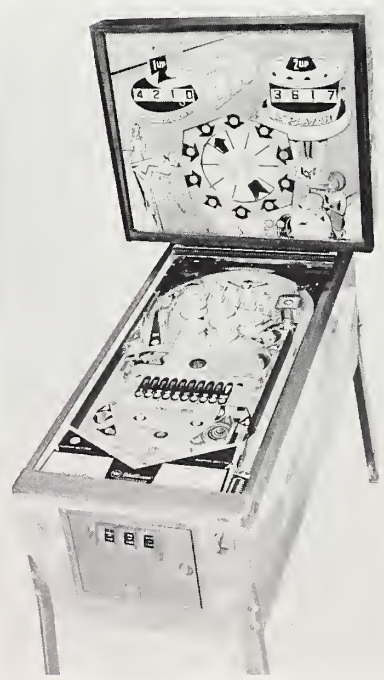

Williams Expo 2 pl

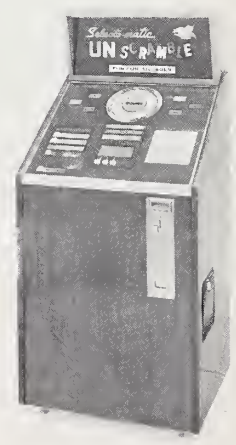

Selecto-Matic Unscramble

PI NGAMES



WILLIAMS

NOVELTIES

SPACE GAMES



Williams Gay 90's 4 pl

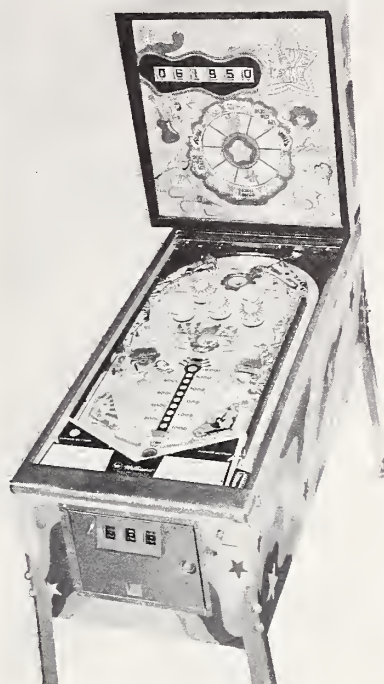

Williams Jive Time 1 pl



Williams Paddock 1 pl



Williams Seven Up 1 pl



Williams Smart Set 4 pl



Aladdin Basketball

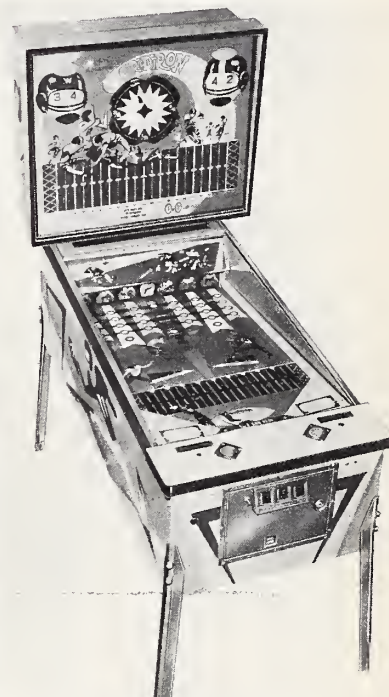

Williams Gridiron 2 pl



Williams 4 Aces 2 pl



Williams Hit and Run 1 pl



Bally Space Flight 1 pl



Cointronics Lunar Landing

# You Won't Find *Bally*

# But We're

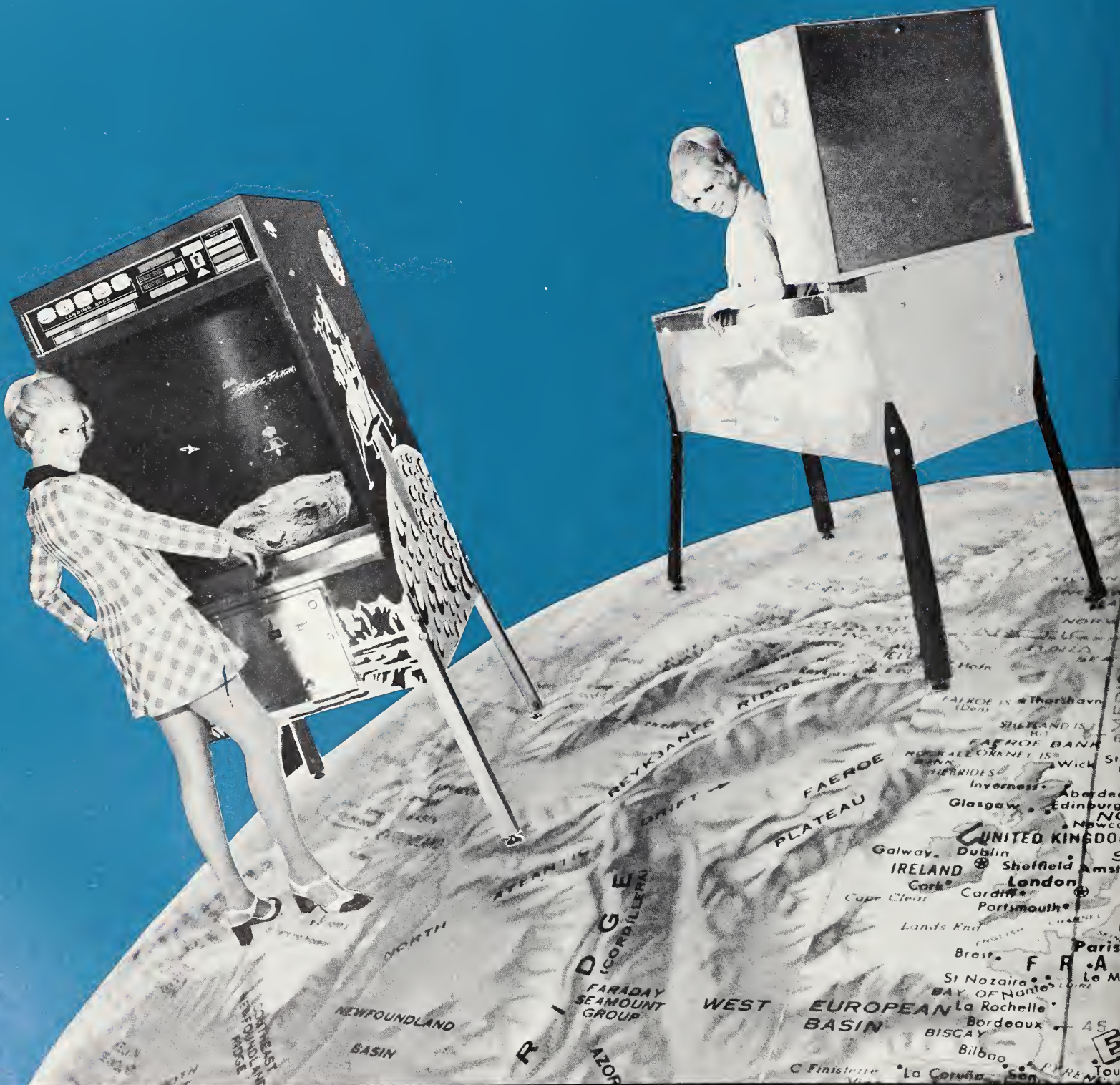

**BALLY MANUFACTURING CORPORATION ★ Chicago, Illinois, U.S.A.**



# or MIDWAY on Any Map

# All Over the Globe



For information regarding  
BALLY OR MIDWAY DISTRIBUTORSHIPS  
CONTACT: ROSS B. SCHEER

Director of Marketing  
BALLY MANUFACTURING CORPORATION  
2640 Belmont Avenue  
Chicago, Illinois 60618, U.S.A.  
(312) 267-6060  
CABLE: BALFAN

**MIDWAY MANUFACTURING COMPANY** • Schiller Park, Illinois, U.S.A.

## TARGET AMUSEMENT MACHINES



Midway Flying Carpet

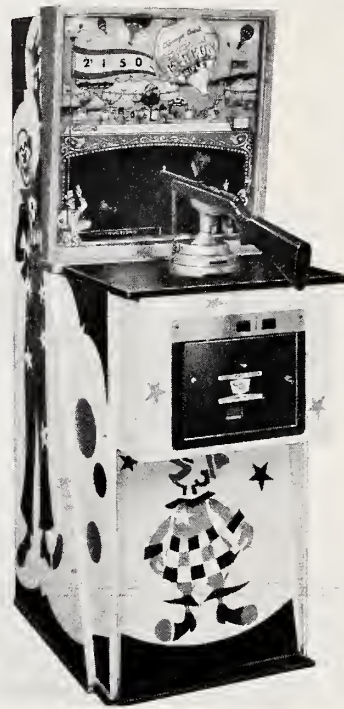

Chicoin Super Circus

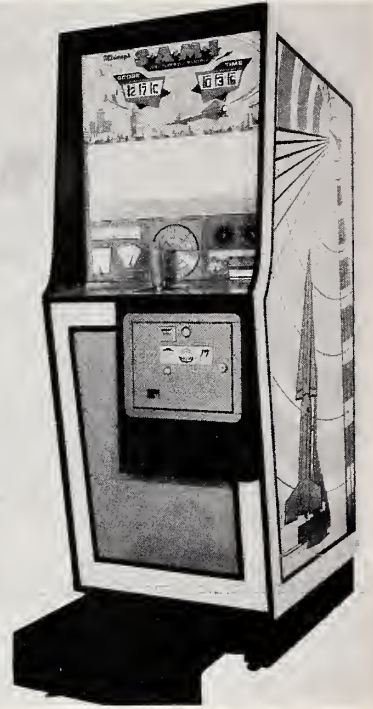

Midway S.A.M.I.



Phonographic Super Missile



Phonographic Tank Assault



Phonographic Attack

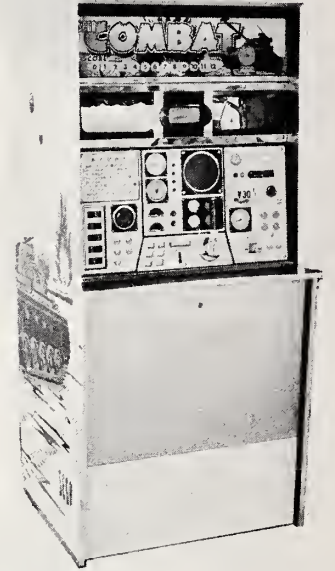

SEGA Combat

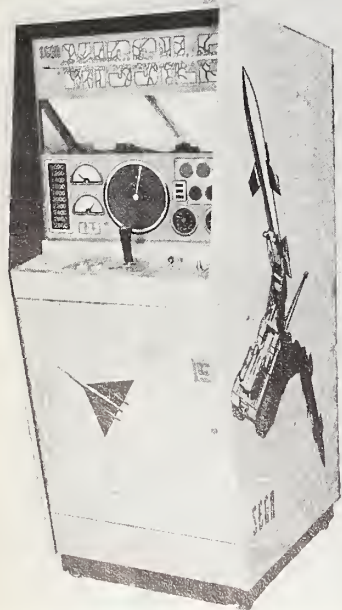

SEGA Missile

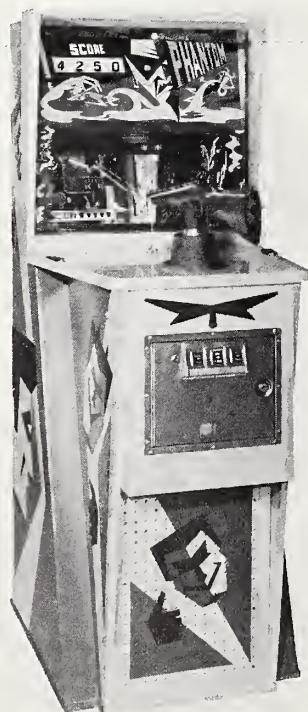

Williams Phantom

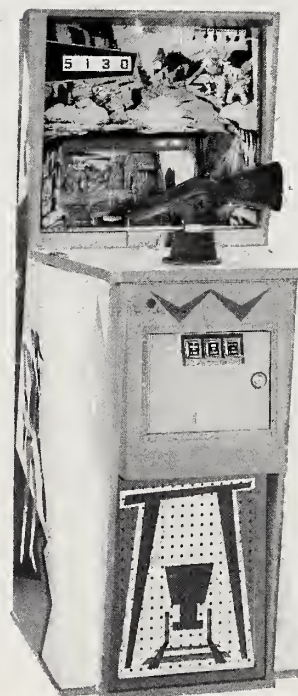

Williams Bonanza



Knight Ent. Your Deal

NUMBER

# LEADER

- Genuine Solid Slate Bed
- Tamper Proof Meter
- Cabinet, Legs and Rails of Mica

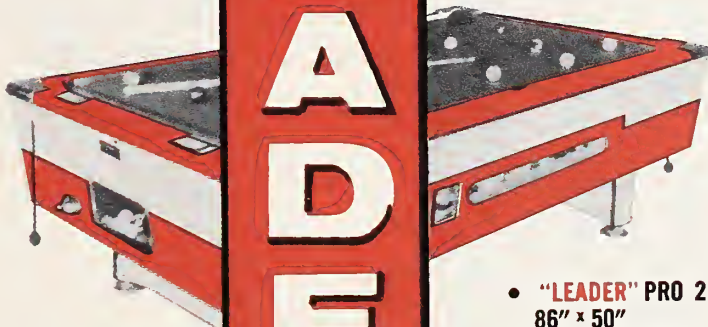

- "LEADER" PRO 2  
86" x 50"
- "LEADER" PRO 3  
93" x 53"
- "LEADER" PRO 4  
103" x 58"

CHOICE  
BY  
NATION'S  
LEADING  
OPERATORS



## "PRO" SERIES

WALNUT

- |                        |                           |
|------------------------|---------------------------|
| • PRO-1 . . . . 78x46  | • Genuine Solid Slate Bed |
| • PRO-2 . . . . 86x50  | • Tamper Proof Meter      |
| • PRO-3 . . . . 93x53  | • Cabinet, Legs and       |
| • PRO-4 . . . . 103x58 | Rails of Mica             |

## POOL TABLES

by

U.S. BILLIARDS TABLES  
FEATURE LAMINATED CABINETS  
OF  
*Wilson Art*  
PLASTICS  
Div. of DART Ind.

**U S BILLIARDS, Inc.**  
Amityville, New York

## RACE GAMES



## QUIZ MACHINES

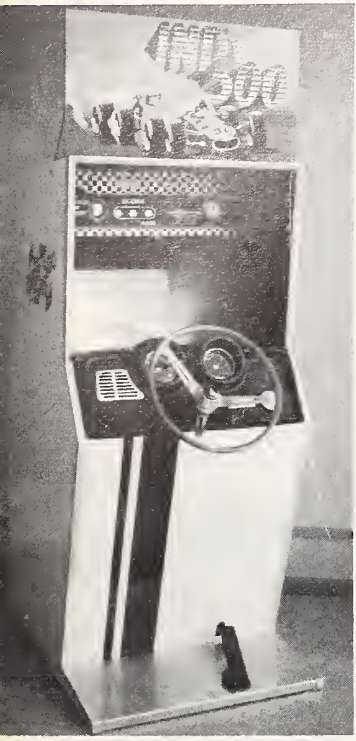

A.C.E. Indy 500

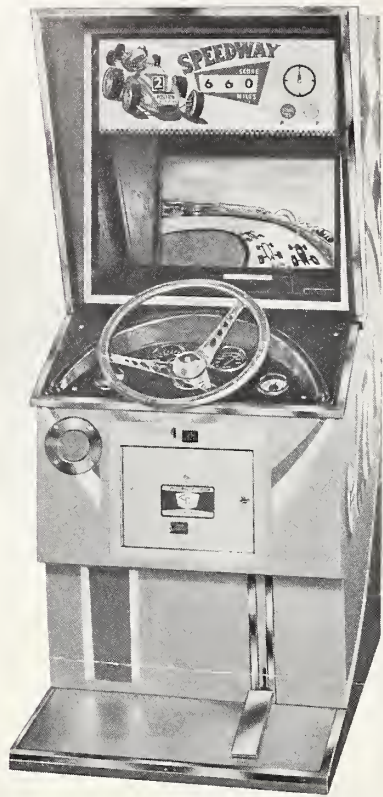

Chicoin Speedway



Chicoin Drive Master

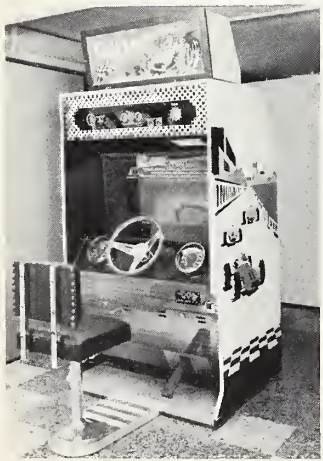

SEGA Indianapolis

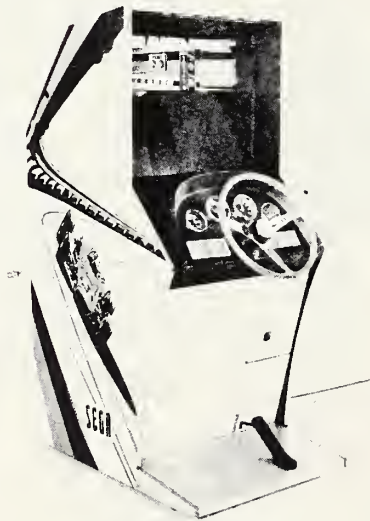

SEGA Grand Prix



Allied Wild Cycle



Nutting Assoc. Sports World

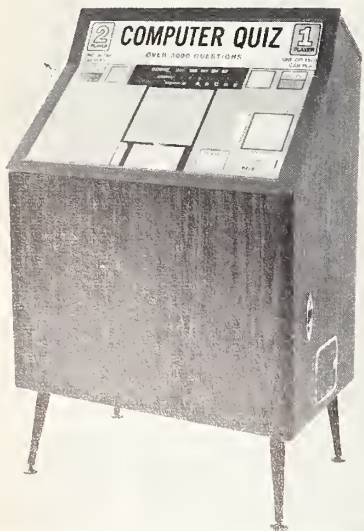

Nutting Assoc. Computer Quiz



Nutting Assoc. Astro Computer



Nutting Ind. Golf I.Q.



Nutting Ind. Dual I.Q.

## SHUFFLE ALLEYS

•

## BIG BALL BOWLERS

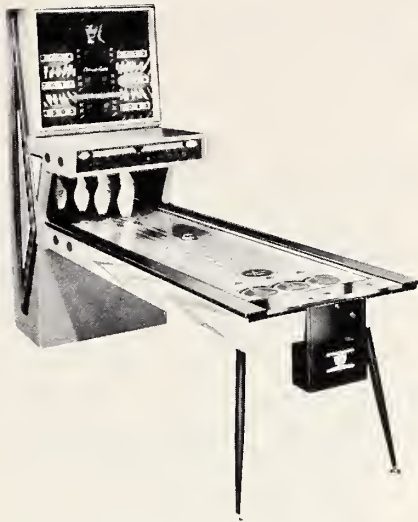

Chicoin Varsity



Chicoin Esquire



United Beta



United Gamma



United Epsilon

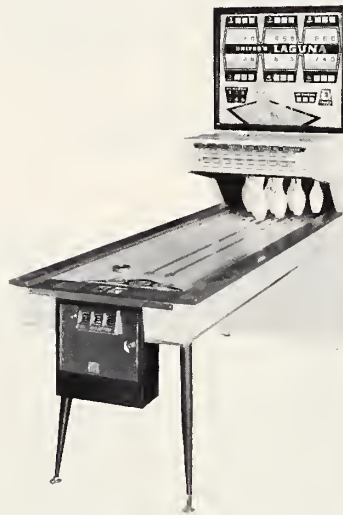

United Laguna



U.S. Billiards Electro-Pool

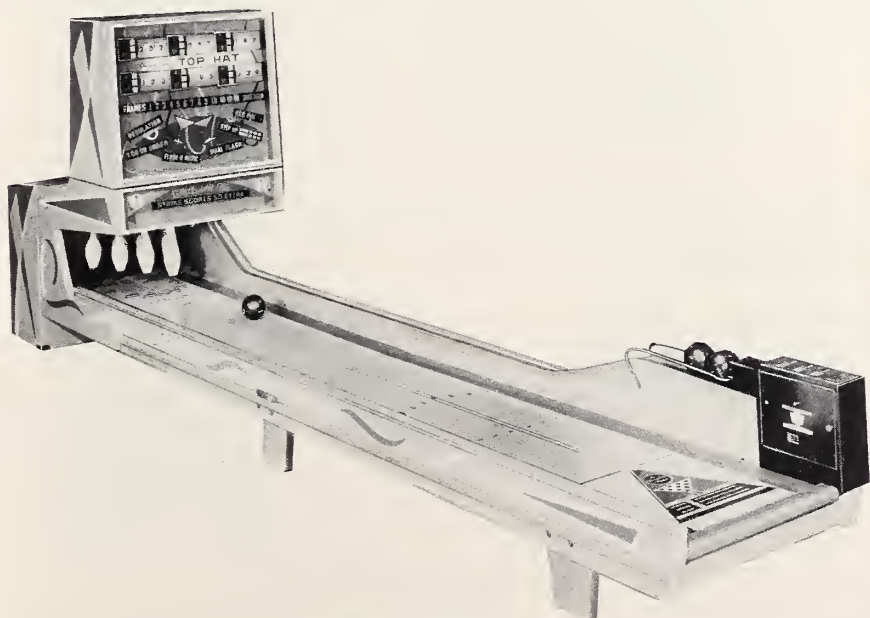

Chicoin Top Hat

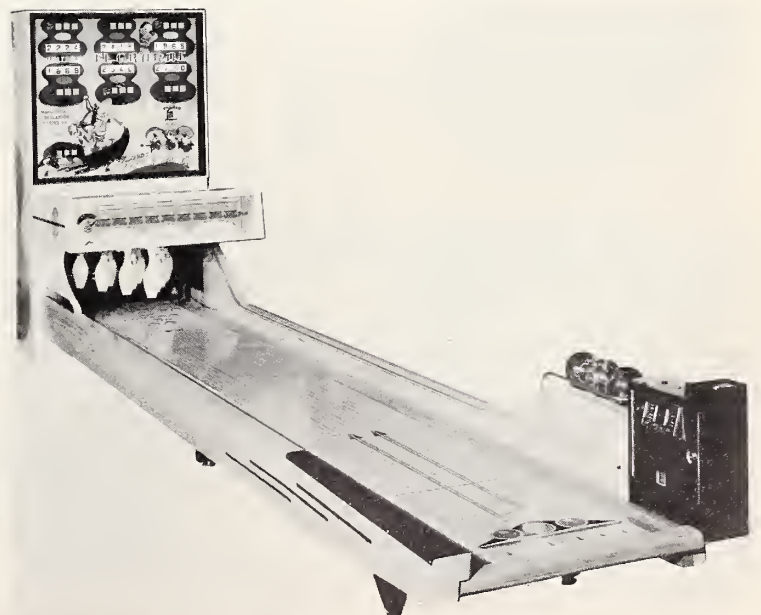

United El Grande

## SOCCER GAMES • SHUFFLEBOARDS • ARCADE NOVELTIES

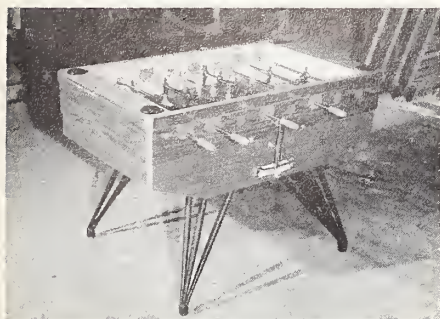

Mondial Flash Soccer

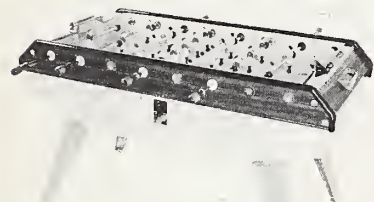

PZP Soccer



Mutoscope Photomatic Photo Studio

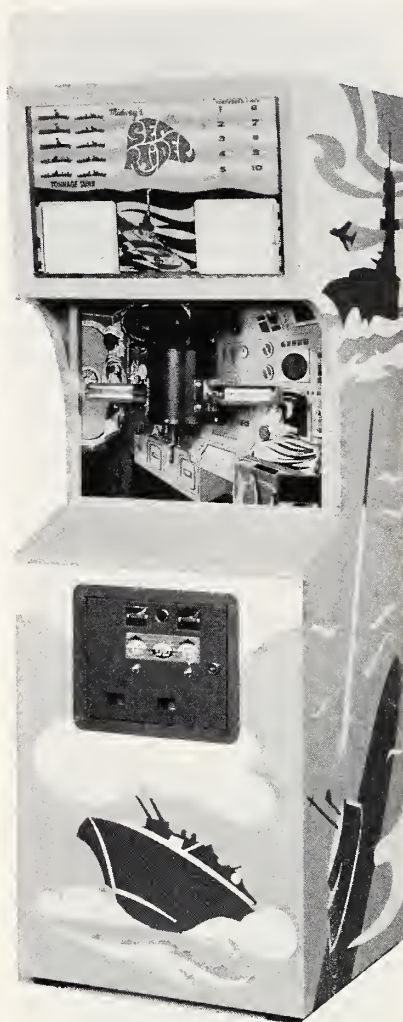

Midway Sea Raider

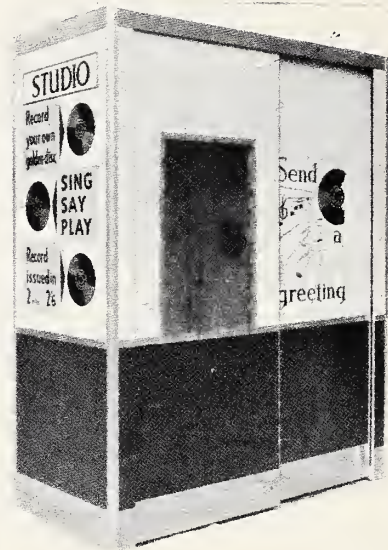

Mutoscope Voice Recorder

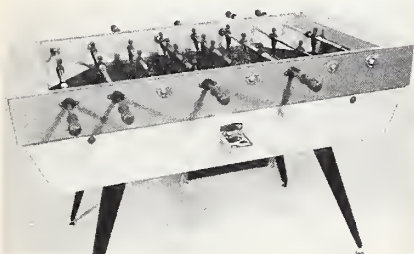

Rene Pierre Football Derby

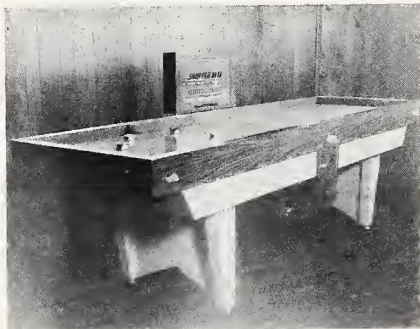

American Shuffleboard Coin-op Shuffle 88

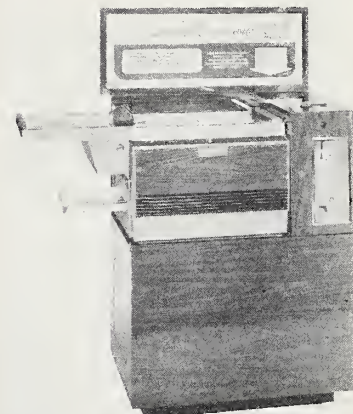

U.S. Coin-a-Copy Photocopy Machine



U.S. Billiards Pro Soccer

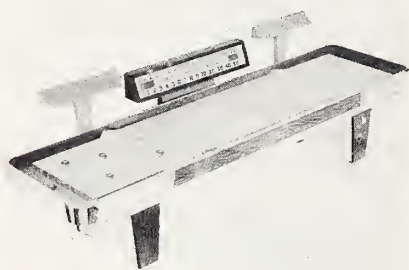

American Shuffleboard Coin-op Bank Shot (12-foot)

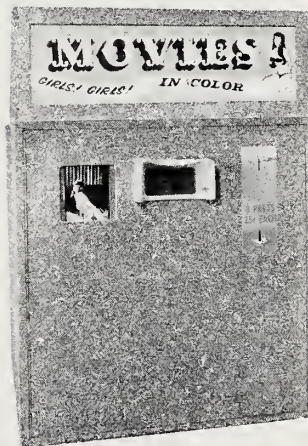

Urban Ind. Panoram



United Billiards Bimbo 3-Ring Circus Puppet Theater



National Shuffleboard Starlite (22-foot)

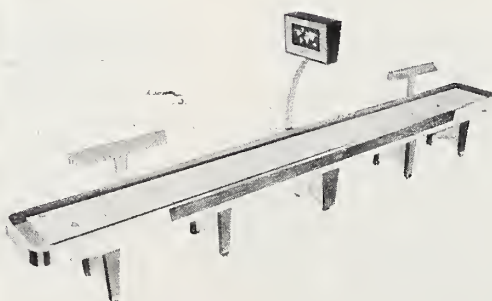

American Shuffleboard Royal American (22-foot)

# what's in an extra 1/8th inch?

Plenty to operators who install 3½ X 7' coin tables and later face expensive replacement of a warping or sagging slate. But don't blame the weather . . . blame the ¾" thickness of the slate.

Then United Billiards began shipping all its 7' Silver Fox and Red Fox tables with a 7/8" slate (that extra 1/8"), and one more problem was solved for the coin table operator.

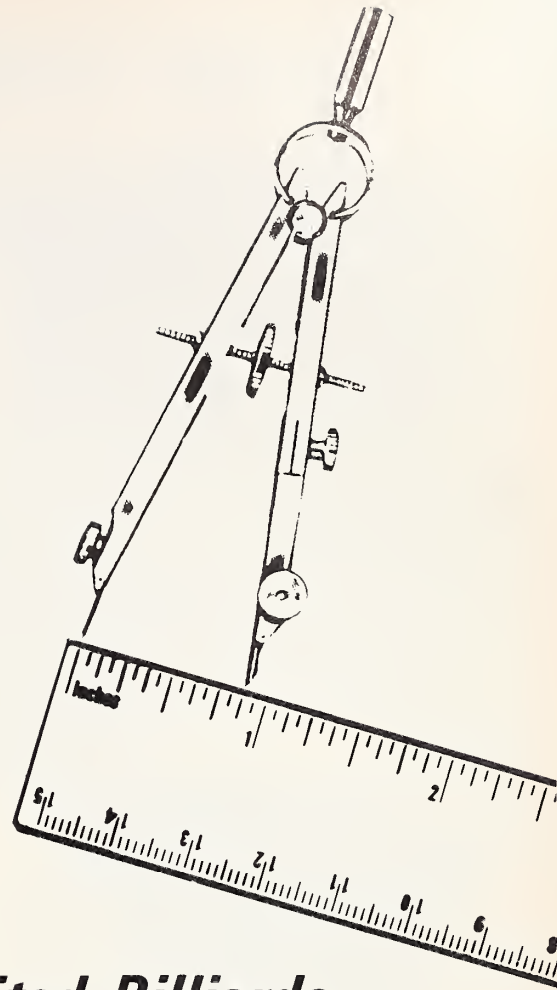

## Another pace-setting feature from United Billiards

*makers of the Operator's Table*



SILVER FOX by United

### Silver Fox Line

*Dramatic design of ashwood cabinet, black mica rails and corners, chrome trim.*

### Red Fox Line

*Traditional rosewood beauty.*

### Red Devil Line

*Startling fire red cabinet, trimmed in black mica and chrome.*

MODELS	OVERALL SIZE	SLATE SIZE
100	78" x 46"	67½" x 35¼" (¾")
200	88" x 51"	75" x 39" (¾")
300	93" x 53"	82" x 42" (¾")
400	103" x 58"	91½" x 57½" (¾")
500	114" x 67½"	107" x 57" (1")
BUNNY POOL	55" x 39"	

**Setting the standards for the coin table industry**



**United** BILLIARDS, INC., 51 PROGRESS ST., UNION, N. J. 07083

Turn to P. 31 and "Get the Message."

# POOL TABLES

Produced July 1969—June 1970

## ALL-TECH

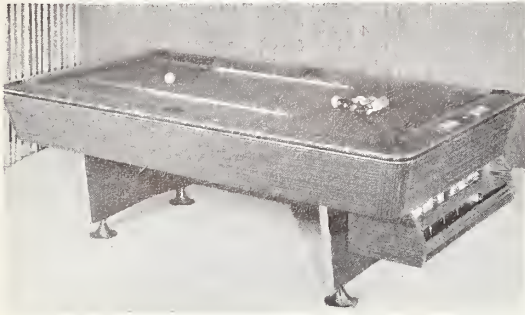

### DIPLOMAT

The Diplomat line features on-location cloth recovery by servicemen; available in three sizes: 49" x 85", 52" x 92" and 57" x 101"; new line comes in a Satin Teak cabinet finish.

## ALL-TECH

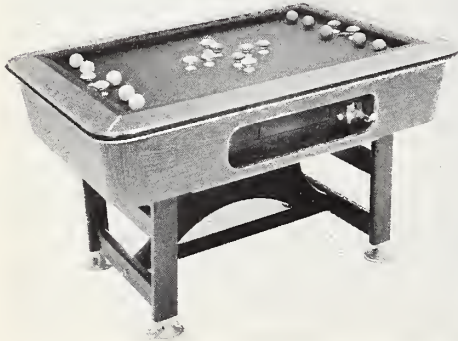

### PLAY-MATE

All-Tech's coin-op rebound table. Sized 42" x 58".

## AMERICAN SHUFFLEBOARD

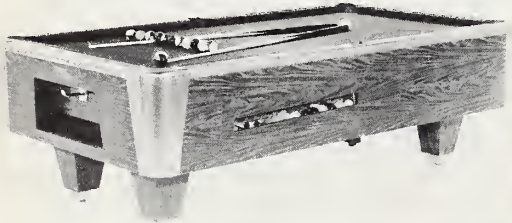

### CLASSIC

American's coin-operated Classic line, featuring a genuine Formica cabinet, is available in 6', 6½', 7' and 8' models.

## BRUNSWICK



### CB-7

The Brunswick Corp's CB-7 coin table measures 53" x 92" including rails. Features on-location cloth replacement. Table is also now available in an 8' version.

## FISCHER

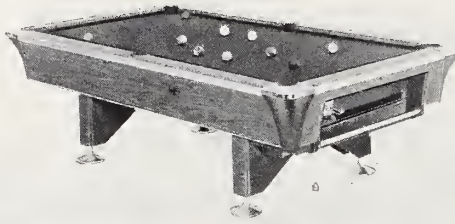

### EMPRESS

Two model sizes available: 105F (59" x 105") and 92F (52" x 92"). Walnut-grained finish with Wedge-lock cushions.

## FISCHER

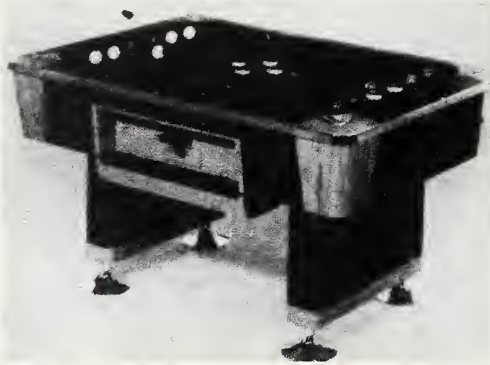

### FIESTA 58

Regulation-sized rebound table (41 3/16" x 57 3/16") in walnut cabinet finish comparable to the Empress.

## FISCHER

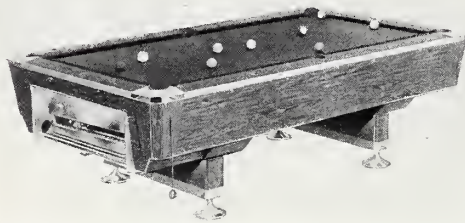

### MARQUEE

Available in two sizes: 100F (56" x 101") and 90F (52" x 92") with guaranteed Steelite modular playfield.

## FISCHER

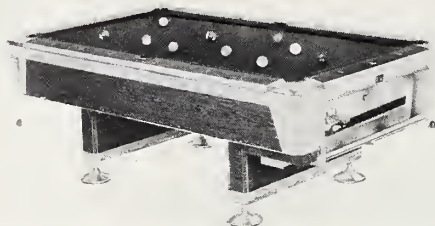

### REGENT

Three sizes available: 101F (56" x 101"), 91F (52" x 92") and 86F (48" x 86"). Choice of Iberian Oak vinyl cabinet or red walnut.

## IRVING KAYE



### APOLLO

The Apollo table line features heavy-gauge steel trim, 3/4" ply construction laminated with walnut mica, available in sizes: Apollo 7 (48" x 85"), Apollo 7 (52" x 92"), Apollo 8 Jr. (101" x 57") and Apollo 8 (105" x 59").

## IRVING KAYE

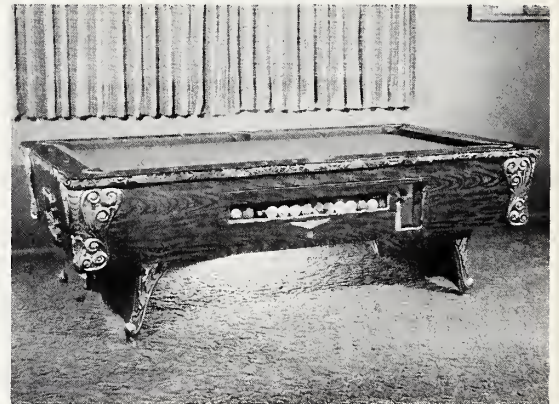

### ANTIQUE APOLLO

A highly-stylized version of the Apollo line, featuring identical construction standards, designed for the plushy-decorated location.

## IRVING KAYE



### THUNDERBIRD

The Kaye Thunderbird line, sized identical to the Apollo line, is designed with vertical cabinet sides for easy installation at the location.

## IRVING KAYE

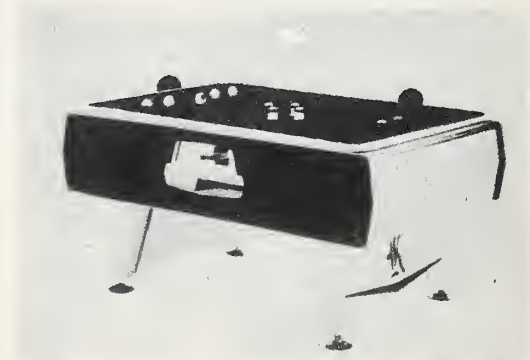

### DELUXE KLUB POOL

Regulation sized available in Red & White or Blue & White finish. Jumbo model, is Formica Teak, measures 45" x 75".



# The Table of TOMORROW is



## here TODAY!...it's **apollo**

Never before have **SO MANY NEW FEATURES** been incorporated into one table!

### **NEW Cabinet**

- \* Completely constructed of 3/4" plywood (no chip board whatever)
- \* Completely finished in high pressure laminate
- \* Nothing at all protrudes beneath the sculptured cabinet
- \* All four corners are finished in magnificent, chrome plated, steel corner sections

### **NEW Coin Mechanism**

- \* All heavy gauge steel
- \* Completely new design to assure maximum security and maintenance-free operation

### **NEW Runways**

- \* Completely constructed of aluminum for trouble-free operation
- \* Cueball returns to shooter's end, while numbered balls go to racker's end

### **NEW Legs**

- \* All aluminum die cast leg post
- \* Virtually indestructible
- \* Entirely new construction design
- \* Legs slip in and bolt rigidly to bottom of cabinet
- \* Extra-large, heavy duty casters
- \* All tables use same size leg

### **NEW Cashbox**

- \* Entire housing constructed of 16 gauge steel
- \* Specially designed for maximum security
- \* Pull-out operation \* Tamper-proof meter

### **NEW Cushions**

- \* Completely constructed of pure rubber
- \* Exclusive design provides the ultimate in true rebound performance
- \* Held to top frame by machine screws
- \* Locked into position by a spline

*plus...*

- Chrome plated, 16 gauge upper and lower corner sections
- All ball return openings trimmed with die cast aluminum frames.
- Two chrome plated, die cast scoring markers
- New improved table cloth assures longer life
- Recessed storage area for cue sticks and racking triangle
- Finest quality accessories
- All ball return openings trimmed with die cast aluminum escutcheons.

#### *Models*

APOLLO 6	APOLLO 7	APOLLO 8 JR.	APOLLO 8
85" x 48"	92" x 52"	101" x 57"	105" x 59"

### **No more Drawers**

Simply remove the new "front door" for service. This newly designed door has one lock and is held in place at three points by a heavy cam and two rods. And in the unlikely case the mechanism must be removed, it can be unbolted and taken out.

**Irving Kaye Co. Inc.**

363 Prospect Place, Brooklyn N.Y. 11238

(212) STerling 3-1200

# POOL TABLES

Produced July 1969 - June 1970

## MURREY & SONS

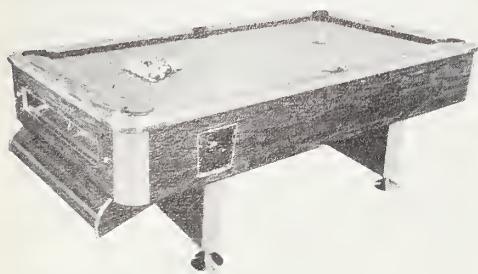

### 3M Series

Model 3M-1 with 4' x 8' x 4" playing area; Model 3M-2 with 4' 4" x 7' 8" playing area; and the Model 3M-3 with 4' 1" x 7' 2" playing area.

## U.S. BILLIARDS

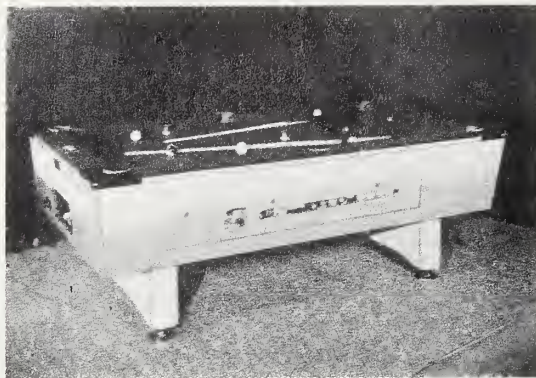

### LEADER

The red and white line of Pro Series tables. Available in 86" x 50", 93" x 53" and 103" x 58".

## UNITED BILLIARDS

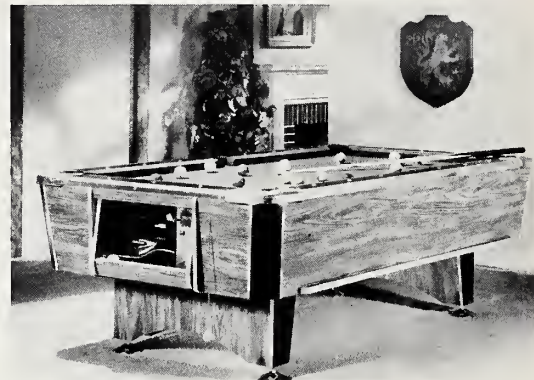

### SILVER FOX

Five sizes are available in this Ashwood Texolite finished line: model 100 (78" x 46"), model 200 (88" x 51"), model 300 (93" x 53"), model 400 (103" x 58") and 500 (114" x 67 1/2").

## NATIONAL

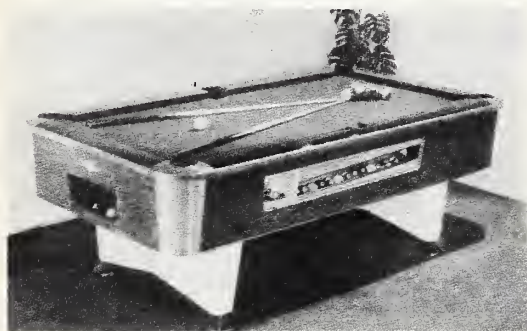

### CORONET

Available in five sizes from Coronet IV (63" x 113") down to Coronet I (46" x 78").

## U.S. BILLIARDS

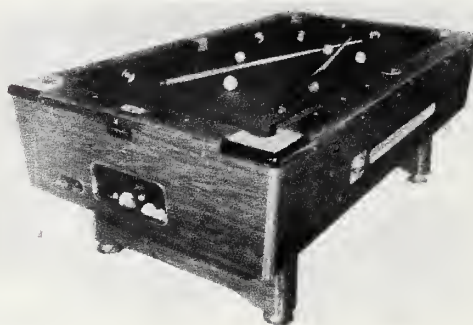

### PRO SERIES

Location table series available in 78" x 46", 86" x 50", 93" x 53" and 103" x 58".

## UNITED BILLIARDS

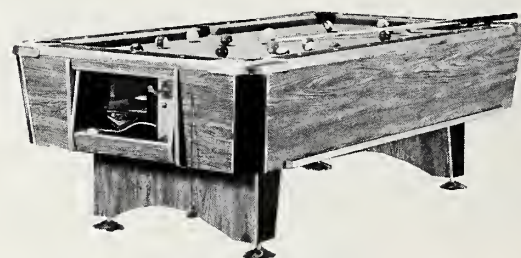

### RED FOX

Same sizes as the Silver Fox line, in a Rosewood Texolite cabinet finish. United also offers a Red Devil cabinet, with brilliant red Texolite balanced with black mica.

## U.S. BILLIARDS



### TIME POOL

Six sizes, including two Snooker models, are available in the Time Pool model. Can convert to standard coin-op.

## UNITED BILLIARDS



### BUNNY POOL

Rebound table (55" x 39")

## U.S. BILLIARDS



### CLUB POOL

Rebound table, measuring 55 1/2" x 39 1/2".

## VALLEY



### 1970 COIN TABLE

Valley Mfg's current table line offers the patented Cats' Eye Cue Ball, sized 2 1/4". Table features Panalite laminated cabinet, rounded rail edges with aluminum trim chrome plated corner brackets and pedestal-type legs.

Why take chances?

coinmen who need information in a hurry, find it in

the Cash Box Coin Directory



# If everybody played pool like he does, we wouldn't make this table.

But let's face it, not everybody has the delicate touch of a Jimmy Caras.  
(He's 5 times Pocket Billiards Champion of the world.)

And so we bring you the Brunswick CB-7.

A specially-built table that can stand up under the constant pounding and rough play a table gets in most coin-op establishments, yet still give you the true tournament playability that Jimmy Caras demands.

To begin with, the legs on this table are sturdy as oaks.

(Tip it over on two legs, you still won't buckle them.)

Return tracks are fast, quiet and absolutely jam-proof.

It has a removable ball box. Extra large coin-box. Easy-off Formica® rails.

And a cloth you can change in minutes without removing the slate.

And when its commercial playing days are over, you can even convert it and sell it as a home pool table with our special conversion kit.

All in all, it's the finest, most service-free coin-op made.

Just what you'd expect from Brunswick.

Makers of fine professional billiard tables since 1845.

## Brunswick

Consumer Division Brunswick Corporation

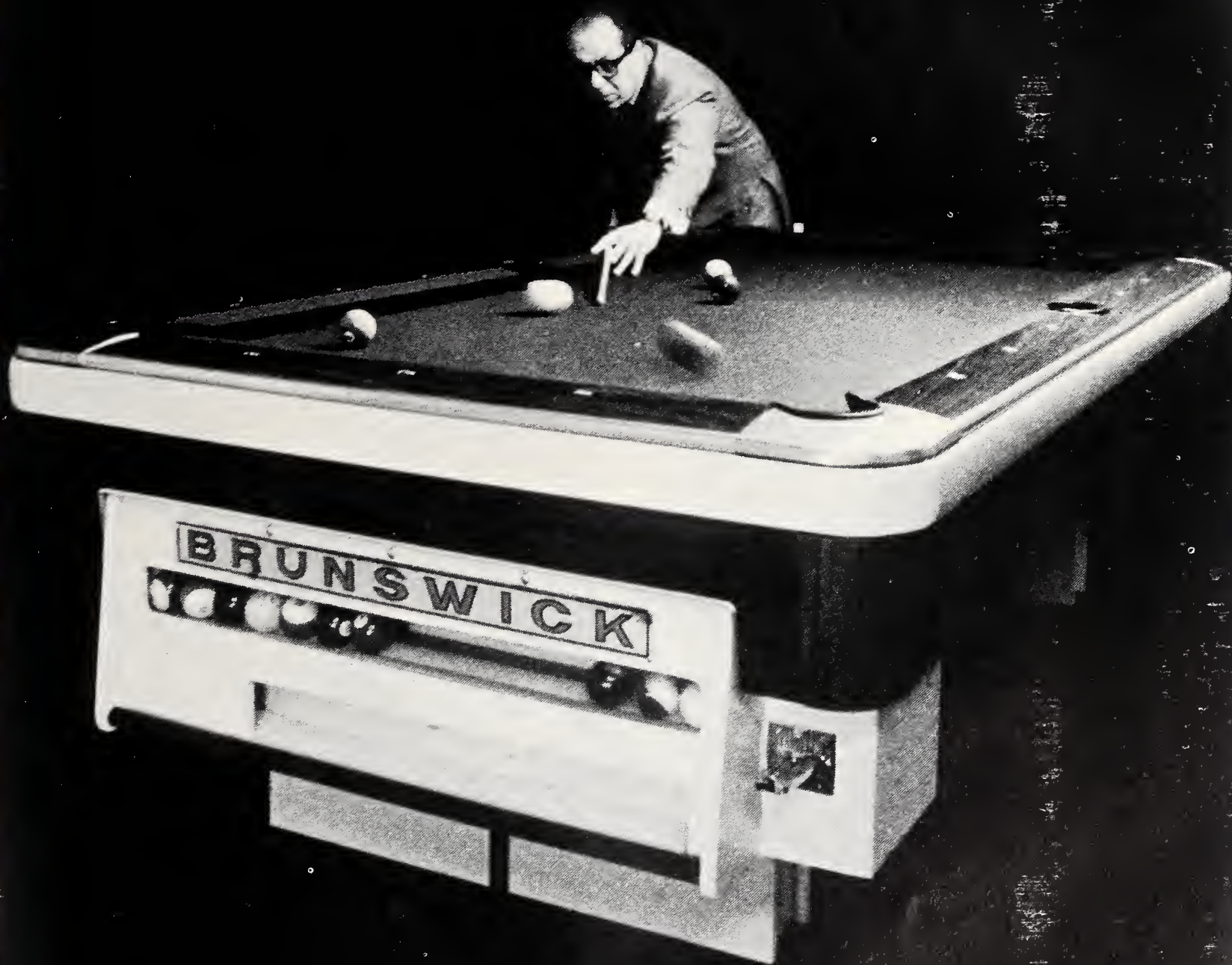

# American Amusement Machine Manufacturers

## ALLIED

ALLIED LEISURE IND. INC.

1780 W. 4th Ave.  
HIALEAH, FLORIDA 33010  
(305) 696-5600  
Bob Braun, Pres.  
Gene Lipkin, Sales Mgr.

(Coin-op Amusement games)

## ALL-TECH

ALL-TECH INDUSTRIES, INC.

14000 N.W. 57th Court  
MIAMI LAKES, FLORIDA  
(305) 821-0150  
Aaron Goldsmith, Pres.  
Mel Blatt, Coin Div. Sales

(Coin-operated pool tables, home tables, kiddie rides, arcade equip.)

## AMERICAN

AMERICAN SHUFFLEBOARD CO.

210 Patterson Plank Rd.  
UNION CITY, N.J. 07087  
(201) UN 5-6633  
Mrs. Mary Cusano, Pres.  
Nick Melone, Gen. Mgr.  
Sol Lipkin, Sales Mgr.

(Coin-op pool tables, home tables, shuffleboards, and supplies)

## AUTO-BELL

AUTO-BELL MFG., INC.

31 W. Kenzie  
CHICAGO, ILLINOIS  
(312) 467-0178  
Zeke Wolf, Pres.

(Counter games and fruit machines)

## AUTO-PHOTO

AUTO-PHOTO CO.

3300 Central Ave.  
LOS ANGELES, CALIF. 90006  
(213) 223-6247  
Verle VanNatten, Gen. Mgr.  
(Coin-op photo studios)

## BALLY

BALLY MANUFACTURING CORP.

2640 Belmont Ave.  
CHICAGO, ILLINOIS 60618  
(312) CO 7-6060  
Bill O'Donnell, Pres.  
Rooss Scheer, Gen. Sales Director  
Paul Calamari, Sales Mgr.

(Pingames, bingos, uprights, fruit machines and arcade games)

## BRUNSWICK

CONSUMER DIV. /  
BRUNSWICK CORP.

69 W. Washington St.  
CHICAGO, ILLINOIS 60602  
(312) 341-7044  
Mac Makenny, Product Mgr.

(Coin-op pool tables, home tables)

## CHICOIN

CHICAGO DYNAMICS INDUSTRIES, INC.

1725 W. Diversey Blvd.  
CHICAGO, ILL. 60614  
(312) WE 5-4600  
Sam Gensburg, Chairman  
Sam Wolberg, Pres.  
Avron Gensburg, V.P.  
Mort Secore, Sales Mgr.

(Pingames, shuffle alleys. Big ball bowlers car race games and arcade equip.)

## COINTRONICS

COINTRONICS, INC.

2560 Wyandotte  
MOUNTAIN VIEW, CALIF.  
(415) 969-0280  
Ransom White, Pres.  
Lance Hailstone, Sales Mgr.

(Coin games and counter pieces)

## EXHIBIT

EXHIBIT SUPPLY CO.

4719 W. Lake St.  
CHICAGO, ILL. 60644  
(312) ES 8-9070

(Photo card vendors)

## AL FISCHER

AL FISCHER & CO.

37 Lafayette Ave.  
FORT THOMAS, KY.  
(806) 261-1575  
Al Fischer, Pres.

(Coin-op kiddie rides)

## FISCHER

FISCHER MFG., INC.

TIPTON, MISSOURI  
(816) 443-5531  
Charles Bailey, Pres.  
Frank Schroeder, Coin Sales  
Lou Wermers, Home Sales

(Coin-op pool tables, home tables)

## FRANTZ

J. F. FRANTZ MFG. CO.

1940 W. Lake St.  
CHICAGO, ILL. 60644  
Johnny Frantz, Pres.

## GOTTLIEB

D. GOTTLIEB & CO.

1140-50 N. Kostner Ave.  
CHICAGO, ILL. 60651  
(312) AL 2-2640  
Dave Gottlieb, Pres.  
Nate Gottlieb, V.P.  
Alvin Gottlieb, Sales  
Judd Weinberg, Sales

(Pin games)

## HAWKINS

PAUL HAWKINS CO.

3119 E. Pennsylvania Ave., Rt. 7  
TUCSON, ARIZ. 85714  
(602) 294-1607  
Paul Hawkins, Pres.

(Coin-op kiddie rides)

## KAYE

IRVING KAYE CO., INC.

363 Prospect Place  
BROOKLYN, N.Y. 11238  
(212) ST 3-1200  
Irving Kaye, Pres.  
Howard Kaye, Sales Mgr.  
Arnold Kaye, Prod. Mgr.

(Coin-op pool tables, home tables, coin-op amusement games, billiard supplies)

## KIDDIETIME

KIDDIETIME CORP.

19 Willow St.  
NATICK, MASS. 01760  
(617) 237-3600  
Sumner Segall, Pres.

(Kiddie rides)

## MARVEL

MARVEL MFG. CO.

2849 West Fullerton  
CHICAGO, ILL.  
(312) 342-2424  
Ted Rubey, Pres.

(Electric scoreboards for shuffleboards)

## MIDWAY

MIDWAY MFG. CO.

3750 River Road  
SCHILLER PARK, ILL. 60176  
(312) 678-1350  
Marcine Wolverton, Pres.  
Larry Berke, Sales Mgr.

(Arcade games)

## MONDIAL

MONDIAL COMMERCIAL CORP.

350 Fifth Ave.  
NEW YORK, N.Y. 10001  
(212) WI 7-5659  
Suren Vesjian, Pres.  
Aspet Varten, Sales  
Dick Sarkisian, Sales

(Amusement games)

## Nutting Associates for COMPUTERS

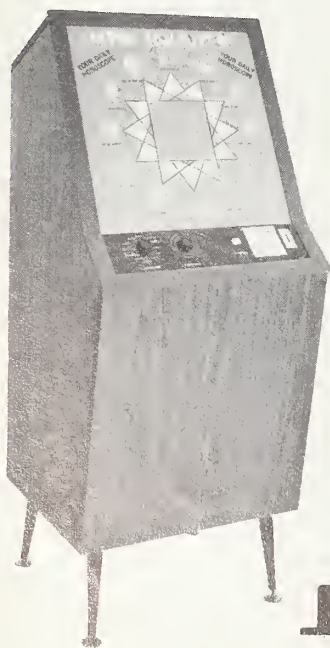

**NA**

**NUTTING ASSOCIATES**

500 ELLIS STREET ■ MOUNTAIN VIEW, CALIFORNIA 94040

■ 415-961-9373

**American Amusement  
Machine Manufacturers**

**MURREY**

MURREY & SONS

14150 S. Figueroa St.  
LOS ANGELES, CAL. 90061  
Gordon Murrey, Pres.

(Coin-op pool tables, home tables,  
billiard supplies)

**MUTOSCOPE**

INTERNATIONAL  
MUTOSCOPE CORP.

11-12 44th Ave.  
LONG ISLAND CITY, N.Y.  
(212) ST 4-3800  
Larry Galante, Pres.  
Joe Bertoloti, Sales

(Voice recorders, photo studio, plastic  
laminating machines, game importers)

**NATIONAL**

NATIONAL SHUFFLEBOARD  
& BILLIARD CO.

Route 22  
GREEN BROOK, N.J.  
(201) 968-0600  
Paul Kotler, Pres.

(Coin-op pool tables, shuffleboards,  
home tables)

**NUTTING**

NUTTING ASSOC.

500 Ellis St.  
MOUNTAIN VIEW, CAL. 94040  
(415) 961-9373  
Bill Nutting, Pres.  
Dave Ralstin, Sales Mgr.

(Coin-op quiz games)

**NUTTING**

NUTTING INDUSTRIES LTD.

3404 N. Holton St.  
MILWAUKEE, WIS. 53212  
(313) 846-8077  
Marty Johnson, Sales Mgr.

**PZP**

PZP ASSOC., INC.

396 Sharon Drive  
CHESHIRE, CONN. 06410  
(203) 272-7523  
Leon Pienkowski, Pres.

(Coin-op table soccer games)

**STANDARD**

**HARVARD**

STANDARD HARVARD  
METAL TYPER, INC.

1318 N. Western Ave.  
CHICAGO, ILL. 60622  
(312) 384-3120

(I.D. tag machine, plastic laminating  
machine)

# Introducing Wild Cycle

## THE HOTTEST WILDEST DAMN MONEY-MAKING MACHINE ON THE MARKET TODAY.

“Wild Cycle” is only one of  
the many creative products  
of Allied Leisure Industries;  
the world’s fastest growing  
designer and manufacturers  
of Fun-Time Products.  
Follow Allied up The Money  
Road to bigger profits.

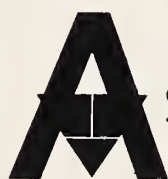

**allied leisure industries inc.**

1780 WEST 4th AVENUE • HIALEAH, FLORIDA 33012 • Phone: (305) 696-5600

DESIGNERS AND MANUFACTURERS OF LEISURE TIME PRODUCTS

# Attention!

DISTRIBUTORS

MANUFACTURERS — OPERATORS

*America's Lowest Life  
Insurance Rates*

*Leading Insurers of Credit Life and  
All Risk Insurance on Equipment on  
Location*

ANNUAL PREMIUMS  
Level Commercial Term

AGE	5 YR.	10 YR.	15 YR.
30	\$308.00	\$ 323.50	\$ 335.50
35	359.00	396.50	426.50
40	469.00	536.50	596.50
45	655.00	741.50	871.50
50	937.00	1,089.50	1,346.50

WAIVER OF PREMIUM BENEFITS AVAILABLE  
MINIMUM POLICY \$100,000.00 — CONVERTIBLE

# SPINDEL

INSURANCE AGENCY INC.

8551 Stony Island Ave.  
Chicago, Ill. 60617  
Area 312-374-3700

4710 N. 16th Street  
Phoenix, Ariz. 85016  
Area 602-279-9509

**American Amusement  
Machine Manufacturers**

## U.S. BILLIARDS

U.S. BILLIARDS, INC.

Edison St.  
AMITYVILLE, N.Y. 11701  
(516) 798-2626  
Albert Simon, Pres.  
Len Schneller, Sales Mgr.  
Stan Levin, Prod. Mgr.

(Coin-op tables, soccer games,  
photocopy machine, home tables)

## UNITED BILLIARDS

UNITED BILLIARDS, INC.

51 Progress St.  
UNION, N.J. 07083  
(201) 686-7030  
Art Daddis, Pres.  
Tom Helle, Gen. Mgr.

(Coin-op pool tables, home tables,  
arcade games)

## UNITED TOOL

UNITED TOOL &  
ENGINEERING CO.

9970 Springfield Pike  
CINCINNATI, OHIO 45215  
(513) 771-3790

(Coin-op kiddie rides)

## URBAN

URBAN INDUSTRIES, INC.

4708 Pinewood Rd.  
LOUISVILLE, KY. 40201  
(502) 969-3227  
Nat Bailen, Pres.

(Film units)

## VALLEY

VALLEY MFG. & SALES CO.

333 Morton St.  
BAY CITY, MICH.  
(517) 892-4536  
Earl Feddick, Pres.  
John Ryan, Sales Mgr.

(Coin-op pool tables, home tables,  
billiard accessories)

## WILLIAMS

WILLIAMS ELECTRONICS  
INC.

3401 N. California Ave.  
CHICAGO, ILL. 60618  
(312) CO 7-2240  
Jack Mittel, V.P.  
Billy DeSelm, Sales Mgr.

(Pin games, arcade games, shuffle  
alleys, bowlers)

## 36 YEARS OF EXPORT EXPERIENCE

### JUKE BOXES

AMI  
SEEBURG  
ROCK-OLA  
WURLITZER

### SHIPMENTS MADE

ALL OVER THE WORLD  
—FROM THE PORT OF  
CHICAGO

FINEST QUALITY—LOWEST  
PRICES ANYWHERE!

### VENDING MACHINES

REBUILT  
COFFEE  
CIGARETTE  
CANDY  
COLD DRINK

Send for complete illustrated Circular and Price List

CABLE: "ATMUSIC"—Chicago  
2122 NORTH WESTERN AVENUE  
CHICAGO, ILLINOIS 60647, U.S.A.



Established 1934

**ATLAS MUSIC COMPANY**

## PORTALE AUTOMATIC SALES

- SOUTHERN CALIFORNIA'S LARGEST DISTRIBUTOR OF COIN OPERATED  
PHONOGRAPHS • AMUSEMENT GAMES • VENDING MACHINES  
POOL TABLES • PARTS AND SUPPLIES

1319 WEST PICO BOULEVARD • (213) 746-1191 • LOS ANGELES, CALIFORNIA 90015

EXCLUSIVE DISTRIBUTOR FOR:

**ROCK-OLA — D. GOTTLIEB & CO.  
CHICAGO COIN — UNITED BILLIARDS  
NUTTING'S IQ COMPUTERS**

Complete Line of Used

**MUSIC — GAMES — ARCADE EQUIPMENT**

Exporting World Wide-Please Contact for Prices

# COIN MACHINE PARTS AND SUPPLIES MFRS.

**ABBOTT COIN COUNTER CO.**  
P.O. Box 1341  
Greenwich, Conn. 06803  
Coin bags, handling & wrapping equipment, changemakers.

**AB-TEX DISTRIBUTORS**  
P.O. Box 5191-2509 Barrow St.  
Abilene, Texas 79605  
100 mm. conversion units

**AEMCO**  
Div. of Midtex  
10 State St.  
Mankato, Minn. 56001  
Coin meters, timers, totalizers; relays & solenoids

**AMERICAN SHUFFLEBOARD CO.**  
210 Paterson Plank Rd.  
Union City, N.J.  
Complete line of shuffleboard supplies

**AQUALARM**  
14238 So. Prairie Ave.  
Hawthorne, Calif.  
Burglar alarm.

**AUTOMATIC ENTS. OF TEXAS INC.**  
4148 Dennis St.  
Houston, Tex. 77004  
Coin chutes; coin meters, timers, totalizers

**AUTOMATIC PRODUCTS CO.**  
301 Chestnut St.  
St. Paul, Minn.  
Coin changers.

**AUTO — MATIC ALARM SYSTEMS**  
1918 South Michigan Ave.  
Chicago, Ill. 60616  
Burglar alarms

**AUTO — PHOTO CO.**  
3300 Central Ave.  
Los Angeles, Cal.  
Photographic supplies for photo studio

**BABACO ALARM SYSTEMS INC.**  
723 Washington St.  
New York, N.Y.  
Burglar alarms.

**BANNER SPECIALTY CO.**  
1641 N. Broad St.  
Philadelphia, Pa.  
Parts & supplies outlet.

**BLOCK & CO. INC.**  
1115 S. Wheeling Rd.  
Wheeling, Ill. 60090  
Coin counters, sorters, chutes, changers, and bags

**BLOCK MARBLE**  
2929 Cheltenham Ave.  
Philadelphia, Pa. 19150  
Parts and supplies outlet.

**BRAD, INC.**  
24011 Talbot St.  
St. Clair Shores, Mich. 48082  
Cue tips, shoe stick point fitter.

**BRANDT AUTOMATIC CASHIER**  
515-517 So. First St.  
Watertown, Wis. 53094  
Coin counters, sorters and wrappers.

**BRUNSWICK CORP.**  
69 W. Washington St.  
Chicago, Ill. 60602  
Cue sticks

**CHASE BAG CO.**  
355 Lexington Ave.  
New York, N.Y. 10017  
Coin bags; packaging & wrapping materials

**CHICAGO LOCK CO.**  
33 W. Belmont Ave.  
Chicago, Ill.  
Machine locks

**COIN ACCEPTORS, INC.**  
4946 Daggett Ave.  
St. Louis, Mo.  
Coin changers, acceptors, repair & accumulating devices.

**COIN — MATIC PRODS. CO.**  
656 Broadway  
New York, N.Y. 10012  
Changemakers & coin mechanisms; coin counters; coin handling & wrapping equipment

**COINTROL CORP.**  
61 E. Main St.  
Forrestville, Conn. 06010  
Coin changers, boxes, meters, timers, totalizers.

**THE CORNELIUS CO.**  
2727 N Ferry St.  
Anoka, Minn. 55303  
CO, carbonators; CO, cylinders; CO, pressure regulators; can openers; changemakers & coin mechanisms; filters; fittings

**COUNTEX CORP.**  
World Trade Center  
San Francisco, Calif.  
Coin sorters, counters & wrappers.

**C. R. DANIELS INC.**  
Daniels, Md. 21033  
Coin bags

**DELTA — SOAR**  
24 Bridge St.  
Watertown, Mass.  
Alarm System

**D & R INDUSTRIES**  
3420 W. Irving Park Rd.  
Chicago, Ill. 60618  
General parts & supplies outlet.

**DYNABALL COMPANY**  
8040 N. Ridgeway  
Skokie, Ill. 60076  
Coin machine & billiard supplies.

**EASTERN NOVELTY DIST. INC.**  
3726 Tonnele Ave.  
N. Bergen, N.J.  
Complete line of billiard accessories.

**EASTERN NOVELTY DIST. INC.**  
(West Coast Branch)  
2939 E. 11th St.  
Los Angeles, Calif.  
Billiard accessories.

**ELECTRO COUNTER & MOTOR CO.**  
2717 N. Ashland Ave.  
Chicago, Ill. 60614  
Coin counters.

**ENM CO.**  
5306 W. Lawrence Ave.  
Chicago, Ill. 60630  
Counters

**H. GREENWALD CO. INC.**  
1340 Metropolitan Ave.  
Brooklyn, N.Y.  
Coin meters, timers, chutes & locks, totalizers, changemakers.

**THE A. W. HAYDON CO.**  
232 N. Elm St.  
Waterbury, Conn. 06720  
Coin meters, timers, totalizers; motors; timers.

**HEATH SALES CO. INC.**  
655 Second St.  
Macon, Ga. 31208  
Coin chutes; coin meters, timers, totalizers.

**IDEN MFG. CO. INC.**  
7524 W. Central Ave.  
River Forest, Ill. 60305  
Coin bags; loading equipment.

**ILLINOIS LOCK CO.**  
303-313 W. Hintz Rd.  
Wheeling Ill.  
Locks and leg levelers.

## 1970 MODEL IS HERE NOW KICK-IT Table-Soccer

Totally enclosed or open models available to operators all over the U.S. and Canada.



The all mechanical game of Soccer that is sweeping the United States. No electrical parts to require special care. Many areas still open for distributors so act soon. Write or Call:

**PZP Associates, Inc.**

Dept CB-1  
396 Sharon Dr., Cheshire, Conn. 06410  
Tel. (203) 272-7523

Manufacturers of

## COIN-OPERATED MOVIE THEATERS 'PANORAMS'

Write for brochure describing all available models and film.

**URBAN INDUSTRIES  
INC.**

P. O. Box 31  
LOUISVILLE, KENTUCKY 40201  
AC 502 — 969-3227

# BRAD INC.

to  
**Table Operators  
Dealers • Suppliers  
and Service Firms**

*our thanks for  
Taking a Tip from BRAD  
and enjoying:*

longer cue life,  
professional ball control,  
foolproof point fitting

*with the exclusive  
BRAD TIP*

*(standard of the industry)*

**BRAD POINT FITTER**  
*(most complete machine for cue  
tip service in the industry)*

**with Cutter Sharpener  
and Scuffer**



CUTTER SHARPENING WHEEL  
CUE TIP SCUFFER

*in service to the  
billiard industry  
BRAD IS BEST!*

**BILLIARD RESEARCH  
and DEVELOPMENT, INC.**

3297 Twelve Mile Road  
Berkley, Mich. 48072  
Tel: (313) 398-8121

**We Extend to**

## “CASH BOX”

Our very sincere congratulations on

your 28th Anniversary

**We of the Westchester Operators Guild are very proud and  
happy to have Cash Box as our friend.**

**Our Best Wishes For Your Continued Success.**

## Westchester Operators Guild Inc.

125 NORTH MAIN STREET  
PORT CHESTER, NEW YORK

**U.S. BILLIARDS'**

**Big  
Soccer**



ENJOY Big Returns  
with 25¢ play

- Manufactured in U.S.A.
- 57½ x 29½" cabinet
- 2 or 4 can play
- 9 Balls to game
- Aluminum Mannikens On Steel Rods
- Ball viewers
- Ball lift guide
- Glass top (tempered)



**COIN MACHINE PARTS AND SUPPLIES MFRS.**

**INTER-COUNTY INDUSTRIES INC.**  
809 Walnut St.  
Redding, Pa.  
Cash boxes.

**INTERNATIONAL MUTOSCOPE  
CORP.**  
Long Island City, L.I.  
Photo studio supplies.

*Thank you for your  
continued support . . .*



**New  
York  
State  
Coin  
Machine  
Association  
Inc.**

Millie McCarthy, Pres.  
Mac Douglas, Treas.  
Mike Mulqueen, Sec.

**HURLEYVILLE, NEW YORK**

**ITT GENERAL CONTROLS INC.**  
200 S. Wolf Rd.  
Des Plaines, Ill.  
Coin counters.

**IRVING KAYE CO. INC.**  
363 Prospect Place  
Brooklyn, N.Y.  
Billiard cues & racks.

**KEENE CORP.**  
4619 N. Ravenswood  
Chicago, Ill. 60640  
Coin handling equipment.

**WALTER KIDDE & CO. INC.**  
675 Main St.  
Belleville, N. J. 07109  
Alarm systems; CO<sub>2</sub> cylinders; locks;  
outdoor structures; refrigerators,  
freezers, coolers; relays & solenoids;  
safes; steam cleaners; valves.

**KLOPP ENGINEERING INC.**  
25551 Schoolcraft  
Livonia, Mich.  
Coin handling equipment.

**LEWIS MERCANTILE CO.**  
40 Great Jones St.  
New York, N.Y.  
Coin bags.

**MARVEL MFG. CO.**  
2847 W. Fullerton Ave.  
Chicago, Ill. 60647  
Score boards & billiard supplies.

**MICRO-MAGNETIC INDS. INC.**  
951 Commercial St.  
Palo Alto, Calif.  
Complete line of coin changers &  
supplies.

**MIKE MUNVES CORP.**  
577 Tenth Ave.  
New York, N.Y.  
Complete coin machine parts &  
supplies.

**MULTI-MESH CORP.**  
8538 W. Grand Ave.  
Rivergrove, Ill. 60171  
Coin changers.

**NADEX IND.**  
220 Delaware Ave.  
Buffalo, N.Y. 14202  
Coin sorters

**NATIONAL LOCK CO.**  
1902 Seventh St.  
Rockford, Ill. 61101  
Coin boxes; leg levelers; locks.

**NATIONAL REJECTORS INC.**  
5100 San Francisco Ave.  
St. Louis, Mo.  
All types of slug rejectors & coin  
handling accessories.

**NEW ORLEANS NOVELTY CO.**  
1055 Dryades St.  
New Orleans, La.  
Coin handling equipment.

**NYACK SLATE CO.**  
Railroad Ave.  
Nyack, N.Y.  
Billiard accessories.

**PACIFIC NIK-O-LOK CO., INC.**  
2421 S. Yates Ave.  
City of Commerce, Calif. 90022  
Changemakers & coin mechanisms;  
locks.

**PEACH STATE DIST. CO.**  
1040 Boulevard S. E. Atlanta, Ga.  
Complete coin machine parts & sup-  
plies.

**PINKERTON ELECTRO-SECURITY  
CO.**  
Div. of Pinkerton's Inc.  
61 Sutton Rd.  
Webster, Mass. 01570  
Alarm systems.

**PRECISION NOVELTY**  
11532 S. Mayfield  
Worth, Ill.  
Shuffle pucks.

**RANDEL LOCK SERVICE CO.**  
21 Primrose Lane  
Valley Stream, L.I.  
Locks, coinbags, alarm systems.

**REDINGTON COUNTERS INC.**  
130 Addison Rd.  
Windsor, Conn. 06095  
Coin counters.

**REED ELECTROMECH CORP.**  
340 Black Hawk Ave.  
Rockford, Ill.  
Slug rejectors, coin changers, meters,  
and dispensers.

**ROWE INTERNATIONAL**  
75 Troy Hills Road  
Whippany, N.J.  
Films for PhonoVue projectors, back-  
ground music tapes, public address  
system accessories

**SAINT CROIX SALES CORP.**  
North Highway 13  
Park Falls, Wisc. 54552  
Billiard cue sticks

**SOLOIN SUPERLOCK CO. INC.**  
115 L. Street S.E.  
Washington D.C. 20003  
Locks, coin meters, totalizers, timers.

**SPINDEL INSURANCE AGENCY INC.**  
8551 S. Stoney Island Ave.  
Chicago, Ill. 60617  
Insurance

**STAATS COIN CHANGER CO.**  
4535 Lincoln Ave.  
Chicago, Ill. 60625  
Coin counters; coin handling & wrap-  
ping equipment.

**STANDARD CHANGE-MAKERS INC.**  
422 E. New York St.  
Indianapolis, Ind.  
Coin sorters and counters.

**STAR TITLE STRIP**  
842 Western Ave.  
Pittsburgh, Pa.  
Title strips.

**STERLING TITLE STRIP CO.**  
1175 Broad St.  
Newark, N.J. 07114  
Title strips.

**SUN-GLO SHUFFLEBOARD SUP-  
PLIES, INC.**  
111-113 Heckel St.  
Belleville, N.J. 07109  
Complete line of shuffleboard supplies.

**TRAK MICROWAVE CORP.**  
P.O. Box 15556  
Tampa, Fla. 33614  
Alarm System

**UNITED BILLIARDS INC.**  
51 Progress St.  
Union, N.J.  
Floor dollies for moving equipment

**VALLEY MFG. & SALES CO.**  
333 Morton St.  
Bay City, Mich.  
Billiard accessories.

**VAN LOCK CO.**  
3609 Church St.  
Cincinnati, Ohio 45244  
Locks

**VENDALARM CO.**  
12135 Chandler  
North Hollywood, Cal. 91607  
Alarm System

**THE VENDO CO.**  
7400 E. 12th St.  
Kansas City, Mo. 64126  
Slug rejectors.

**WICO CORP.**  
2913 N. Pulaski Ave.  
Chicago, Ill. 60641  
Complete coin machine parts & sup-  
plies.

**WOODBINE MFG. Co.**  
Woodbine, Iowa 51579  
Lift gates

**THE WURLITZER CO.**  
North Tonawanda, N.Y.  
Public address system accessories

**YATES APPLIANCE DALI SALES**  
1300 W. Fond Du Lac Ave.  
Milwaukee, Wisc. 53205  
Hauling equipment

**ELECTRIC SCOREBOARDS . . . 2 MODELS**

10¢ 1-player or 2-player by simple  
plug switchover. Also 2 for 25¢ play.  
Easily serviced. Large metal coin box.

**OVERHEAD MODEL**  
(Natural finish hardwood cabinet)  
Two-faced. Scores 15-21 and/or 50  
pts. F. O. B. Chicago . . . . . \$169.50  
**SIDE-MOUNT MODEL**  
(Walnut Formica finish)  
F. O. B. Chicago . . . . . \$249.50

Large selection  
of billiard cloth,  
balls and cue  
sticks---

Write for  
1970  
Catalog

**Heavy-Duty COIN BOX**



Made of steel with dark brown baked enamel finish.  
10¢ or 25¢ operation. Large coin capacity w/Ntl. Rejec-  
tors. Size: 8" x 16" x 4". Elec. counter opt'l.

Terms 1/3 dep., Bal. C.O.D. or S.D.

**MARVEL Mfg. Company**

2849 W. Fullerton Chicago Ill. 60647  
Phone (312) 342 2424

**BEST WISHES  
To  
CASH BOX**

ON YOUR 28th ANNIVERSARY

**HASTINGS DISTRIBUTING Inc.**

(Since 1932)

6100 W. BLUEMOUND ROAD, MILWAUKEE 53213, WISC.

**HAVING TROUBLE PLAYING STEREO RECORDS  
ON SEEBURG MONAURAL PHONOGRAPHS?**

**NOW** A REPLACEMENT  
STEREO/MONAURAL CARTRIDGE

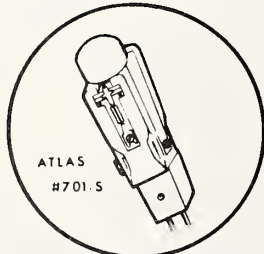

ENDS sound distortion, scratchy  
background noise, needle skipping,  
short record life on Seeburg Phono-  
graphs models B-C-G-W-R-J-U-K-L-  
161-201

**SIMPLE INSTALLATION**

Just change cartridge as easy as  
changing needles. INTRODUCTORY OFFER:

1 CARTRIDGE plus 1 EXTRA SET OF NEEDLES only **\$35.00**

WRITE FOR QUANTITY PRICES — ORDER FROM

**WICO CORPORATION**

2913 N. Pulaski Rd., Chicago, Ill. (312) 685-3000





## ROCK-OLA

Rock-Ola Manufacturing Corp.  
800 North Kedzie Ave.  
Chicago, Illinois  
(312) NE-8-7600  
Ed Doris, executive v.p.  
Les Rieck, sales manager, music  
Hugh Gorman, sales manager, vending

### (Distributors)

ACTIVE AMUSEMENT MACHINES CO.  
Philadelphia, Pa.

ACTIVE AMUSEMENT MACHINES CO.  
Scranton, Pa.

ACE-HIGH DISTRIBUTORS  
Lackawanna, N.Y.

ADVANCE DIST. INC.  
Syracuse, N.Y.

ADVANCE MUSIC INC.  
Minneapolis, Minn.

A.M.A. DISTRIBUTORS, INC.  
New Orleans, La.

B. D. LAZAR CO.  
Pittsburgh, Pa.

BEST DIST. INC.  
Salt Lake City, Utah

BETSON ENTERPRISES, INC.  
North Bergen, N.J.

BIRD MUSIC DIST., INC.  
Manhattan, Kan.

H. B. BRINCK  
Butte, Montana

ELI ROSS DIST., INC.  
Jacksonville, Fla.

ELI ROSS DIST., INC.  
Miami, Fla.

EMPIRE COIN MACHINE EXCHANGE  
Milwaukee, Wis.

EMPIRE DIST., INC.  
Chicago, Ill.

EMPIRE DIST., INC.  
Detroit, Mich.

EMPIRE DIST., INC.  
Grand Rapids, Mich.

EMPIRE DIST., INC.  
Green Bay, Wis.

FLOWER CITY DIST., INC.  
Rochester, N.Y.

FRANCO DIST. CO., INC.  
Montgomery, Ala.

GENERAL VENDING SALES CORP.  
Baltimore, Md.

GLOBE AUTOMATIC VENDING MACH. CO., INC.  
Quincy, Mass.

GREATER SOUTHERN DIST. CO.  
Atlanta, Ga.

H. Z. VENDING & SALES CO., INC.  
Omaha, Neb.

LE CORP.  
Houston, Tex.

LESTOURGEON DIST. CO.  
Charlotte, N.C.

MONROE COIN MACH. EXCH., INC.  
Cleveland, Ohio

MONROE COIN MACH. EXCH., INC.  
Dayton, Ohio

MOUNTAIN DISTRIBUTORS  
Denver, Colo.

MUSICAL SALES, INC.  
St. Louis, Mo.

PACIFIC COIN MACHINE DIST., INC.  
Modesto, Cal.

PORTALE AUTOMATIC SALES CO.  
Los Angeles, Cal.

RAINBOW ENTERPRISES, INC.  
Seattle, Wash.

S & M DIST. CO., INC.  
Memphis, Tenn.

SANDERS DIST. CO.  
Nashville, Tenn.

SEACOAST DIST.  
Elizabeth, N.J.

ALBERT SIMON INC.  
New York, N.Y.

STATE MUSIC DIST., INC.  
Dallas, Tex.

S. L. STIEBEL CO.  
Louisville, Ky.

TULSA BILLIARD SUPPLY, INC.  
Tulsa, Okla.

VENDING MACHINE EXCH.  
Bristol, Va.

WALLACE & WALLACE MUSIC, INC.  
Oak Hill, W. Va.

# U.S. Phonograph Distributors

Refer to Distributor-Jobber List  
for Complete Dealer Information

## ROWE

Rowe International, Inc.  
(Div. of Triangle Industries)  
75 Troy Hills Road  
Whippany, New Jersey  
(201) TU-7-0400  
Joe Barton, v.p. marketing  
Paul Huebsch, music sales

### (Distributors)

ADVANCE DIST.  
St. Louis, Mo.

ATLAS MUSIC CO.  
Chicago, Ill.

AUTOMATIC MUSIC DIST.  
Oklahoma City, Okla.

BANNER SPECIALTY CO.  
Pittsburgh, Pa.

BUSH INTERNATIONAL  
Jacksonville, Fla.

BUSH INTERNATIONAL  
Miami, Fla.

BUSH INTERNATIONAL  
Richmond, Va.

BUSH INTERNATIONAL  
Tampa, Fla.

CENTRAL SALES, INC.  
Houston, Tex.

CIRCLE INTERNATIONAL  
Los Angeles, Cal.

DIAMOND DIST. CO.  
Denver, Colo.

DIAMOND DIST. CO.  
Salt Lake City, Utah

GARRISON SALES CO.  
Phoenix, Ariz.

HERMITAGE MUSIC CO.  
Birmingham, Ala.

HERMITAGE MUSIC CO.  
Nashville, Tenn.

J & J DIST., INC.  
Indianapolis, Ind.

J & J DIST. CO.  
Cincinnati, Ohio

K. C. SALES & SERVICE  
St. Paul, Minn.

J. H. LYNCH DIST. CO., INC.  
New Orleans, La.

MILLER DIST. CO.  
Grand Rapids, Mich.

MILLER DIST. CO.  
Germdale, Mich.

PEACH STATE DIST.  
Atlanta, Ga.

PEACH STATE MUSIC CO.  
Macon, Ga.

PEACH STATE TRADING CO.  
Columbia, S.C.

PIONEER SALES AND SERVICE  
Milwaukee, Wis.

DAVID ROSEN, INC.  
Philadelphia, Pa.

ROVENDCO INTERNATIONAL  
San Francisco, Cal.

ROVENDCO INTERNATIONAL  
Seattle, Wash.

RUNYON SALES CO.  
New York, N.Y.

RUNYON SALES CO.  
Springfield, N.J.

S & H DIST. CO.  
Shreveport, La.

SANTONE SALES CO.  
San Antonio, Tex.

SHAFFER DIST. CO.  
Cleveland, Ohio

SHAFFER DIST. CO.  
Columbus, Ohio

SHELDON SALES DIST. CORP.  
Tonawanda, N.Y.

SOUTHERN AMUSEMENT CO.  
Memphis, Tenn.

SOUTHERN VENDING SALES CORP.  
Dallas, Tex.

TRIMOUNT AUTOMATIC SALES CO.  
Dedham, Mass.

W. B. MUSIC CO.  
Kansas City, Mo.

## SEEBURG

The Seeburg Sales Corp.  
1500 North Dayton St.  
Chicago, Illinois  
(312) MI-2-0800  
Ed Blankenbeckler, v.p., music sales  
Bob Breither, vice president, vending  
sales

### (Distributors)

ADVANCE AUTOMATIC SALES CO.  
San Francisco, Cal.

ATLANTIC CONNECTICUT CORP.  
East Hartford, Conn.

ATLANTIC NEW JERSEY CORP.  
Elizabeth, N.J.

ATLANTIC NEW YORK CORP.  
New York, N.Y.

ATLAS MUSIC CO.  
Pittsburgh, Pa.

DAVIS DIST. CORP.  
Syracuse, N.Y.

DAVIS DIST. CORP.  
Buffalo, N.Y.

DAVIS DIST. CORP.  
Albany, N.Y.

DAVIS DIST. CORP.  
Rochester, N.Y.

DUNIS DIST. CO.  
Portland, Ore.

EASTERN MUSIC SYSTEMS  
Philadelphia, Pa.

EASTERN DISTRIBUTORS, INC.  
Baltimore, Md.

H. A. FRANZ & CO.  
Houston, Tex.

LIEBERMAN MUSIC CO.  
Minneapolis, Minn.

S. L. LONDON VENDING CO., INC.  
Milwaukee, Wis.

L & R DIST. INC.  
St. Louis, Mo.

MARTIN & SNYDER CO.  
Detroit, Mich.

MARTIN & SNYDER OF OHIO  
Cleveland, Ohio

MODERN VENDING CO., INC.  
Indianapolis, Ind.

PHILIP MOSS & CO.  
Des Moines, Iowa

PHILIP MOSS & CO.  
Omaha, Neb.

MUSIC-VEND DIST. CO.  
Seattle, Wash.

## MUSIC and GAMES OPS

Round out Your Route -  
Earn a Better Buck  
OPERATE

## CANDIMAT

- best profit for your investment dollar.
- more potential locations open to **you** than with anything else on the market today

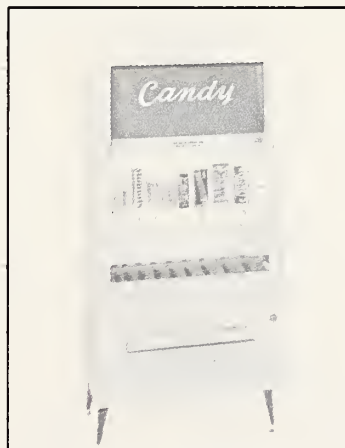

MADE FOR UNIVERSAL  
VENDORS BY WESTING-  
HOUSE.

We are Distributors for These Leading Manufacturers GOTTLIB • BALLY • CHICAGO COIN • AUTOMATIC PRODUCTS INTERNATIONAL MUTOSCOPE • WURLITZER • FISCHER • IRVING KAYE • U.S. BILLIARDS • MIDWAY • COINTRONICS

Our Service • Our Prices • Will Please You

# BILOTTA enterprises

224 No. Main St., Newark, N.Y.  
388 Broadway, Albany, N.Y.

From Bilotta's

# COMPLETE ONE STOP SERVICE REPRESENTING LEADING MANUFACTURERS

# U.S. Phonograph Distributors

Refer to Distributor-Jobber List  
for Complete Dealer Information

## SEEBURG

(CONTINUED)

O'CONNOR DIST. CO., INC.  
Dallas, Tex.  
OPERATOR SALES INC.  
New Orleans, La.  
SAMMONS-BENNINGTON CO.  
Memphis, Tenn.  
SAMMONS-PENNINGTON NASHVILLE, INC.  
Nashville, Tenn.  
SEEBURG CENTRAL DIST. CO.  
North Kansas City, Mo.  
SOUTH ATLANTIC DIST. CO.  
Atlanta, Ga.  
SOUTH ATLANTIC DIST. CO.  
Miami, Fla.  
SOUTH ATLANTIC DIST. CO.  
Jacksonville, Fla.  
SOUTH ATLANTIC DIST. CO.  
New Orleans, La.  
SOUTH ATLANTIC DIST. CO.  
Raleigh, N.C.  
SOUTH ATLANTIC DIST. CO.  
Columbia, S.C.  
STRUVE DIST. CO., INC. OF COLORADO  
Denver, Colo.  
STRUVE DIST. CO.  
Los Angeles, Cal.  
STRUVE DIST. CO.  
Phoenix, Ariz.  
STRUVE DIST. CO.  
Salt Lake City, Utah  
SUTHERLAND DIST. CO., INC.  
San Antonio, Tex.  
SUTHERLAND DIST. CO.  
El Paso, Tex.  
SUTHERLAND DIST. CO.  
Oklahoma City, Okla.  
WORLD-WIDE DIST.  
Chicago, Ill.  
W. S. DIST. INC.  
Randolph, Mass.

## WURLITZER

The Wurlitzer Company  
North Tonawanda, New York  
(716) NX-3-2500  
Roy Waltemade, v.p. & manager,  
N. Tonawanda Div.  
Bob Bear, sales director

(Distributors)

MICKY ANDERSON AMUSEMENT CO.  
Erie, Pa.  
ANGOTT DIST. CO., INC.  
Detroit, Mich.  
BANNER SPECIALTY CO.  
Philadelphia, Pa.  
BILOTTA ENTERPRISES, INC.  
Newark, N.Y.  
BILOTTA ENTERPRISES, INC.  
Albany, N.Y.  
BRADY DIST. CO.  
Charlotte, N.C.  
BRANDT DIST. CO., INC.  
St. Louis, Mo.  
CENTRAL DIST. CO.  
Omaha, Neb.  
CLEVELAND COIN INTERNATIONAL  
Cleveland, Ohio  
CLEVELAND COIN INTERNATIONAL  
Toledo, Ohio

COMMERCIAL MUSIC CO., INC.  
Dallas, Tex.

CO-OPERATIVE DIST. CO.  
Louisville, Ky.

GATEWAY CO-OPERATIVE DIST. CO.  
Evansville, Ind.

CRUZE DIST. CO., INC.  
Charleston, W. Va.

CULP DIST. CO.  
Oklahoma City, Okla.

DRACO SALES CO.  
Denver, Colo.

F.A.B. DIST. CO., INC.  
Pensacola, Fla.

GODWIN DIST. CO., INC.  
North Little Rock, Ark.

GULF COAST DIST. CO.  
Houston, Tex.

GULF COAST DIST. CO.  
San Antonio, Tex.

HARPER'S CONSOLIDATED MUSIC CO.  
Las Cruces, N.M.

LEW JONES DIST. CO., INC.  
Indianapolis, Ind.

MUSIC DIST. CO.  
Pittsburgh, Pa.

MUSICAL DIST. CORP.  
Brooklyn, N.Y.

MUSICAL DIST. CORP.  
New York, N.Y.

NATIONAL AMUSEMENT INC.  
Honolulu, Hawaii

NATIONAL COIN MACHINE EXCHANGE  
Chicago, Ill.

NORTHWEST SALES CO.  
Seattle, Wash.

NORTHWEST SALES CO. OF OREGON  
Portland, Ore.

ROCK CITY DIST. CO., INC.  
Nashville, Tenn.

ROTH NOVELTY CO.  
Wilkes-Barre, Pa.

ROYAL DIST. CORP.  
Cincinnati, Ohio

ROYAL DIST. CORP.  
Columbus, Ohio

SANDLER VENDING CO.  
Minneapolis, Minn.

SOUTHERN MUSIC DIST. CO., INC.  
Orlando, Fla.

SOUTHERN MUSIC DIST. CO., INC.  
Jacksonville, Fla.

STATE SALES AND SERVICE CORP.  
Baltimore, Md.

UNITED, INC.  
Brookfield, Wis.

UNITED DIST., INC.  
Wichita, Kan.

VALIANT AMUSEMENT, INC.  
Phoenix, Ariz.

WURLITZER DIST. CORP.  
Atlanta, Ga.

WURLITZER DIST. CORP.  
Columbia, S.C.

WURLITZER DIST. CORP.  
East Hartford, Conn.

WURLITZER DIST. CORP.  
Los Angeles, Cal.

WURLITZER DIST. CORP.  
New Orleans, La.

WURLITZER DIST. CORP.  
San Francisco, Cal.

WURLITZER DIST. CORP.  
Newton Highlands, Mass.

## A.C.A. (NSM, GmbH)

A.C.A. Sales and Service  
2230 E. 14th St., Oakland, Cal.  
(415) 533-3421  
2891 W. Pico Blvd., L.A., Cal.  
(213) 737-0104  
Henry Leyser, Pres.  
Mickie Greenman, VP Sales

(Exclusive U.S. and Canadian representatives for NSM, GmbH, W. Germany, phonograph products)

(A.C.A. Distributors)

A.C.A. (Oakland and Los Angeles offices)

ALL-COIN EQUIPMENT CO.,  
San Antonio, Texas

GRECO BROS. DIST. CO.  
Glasco & Albany, N.Y.

INT'L MUTOSCOPE SALES CORP.  
New York City

LEONARD MUSIC CO.  
Adrian, Michigan

MODERN COIN INC.  
Minot, North Dakota

MOHAWK MUSIC CO.  
Greenfield, Mass.

RIES MUSIC CO.  
Dennison, Iowa

SOUTHEASTERN DIST. INC.  
Norfolk, Virginia

SPECIALTY SALES CORP.  
Chicago, Illinois

STANDARD DISTRIBUTING  
Seattle, Washington

SUBURBAN VENDING  
Sussex, Wisconsin

UNIQUE MUSIC CO.  
St. Louis, Mo.

## CAMERON

Cameron Musical Ind., Ltd.  
82 S. Bayles Ave.  
Port Washington, N.Y.  
(516) 767-6662  
Jack Gordon, Pres.  
Dick Murphy, Sales

(Cameron phonograph distributed exclusively in U.S.A. by Miamco, Inc., Div. of Vendo Co.)

(Miamco Distributors)

LOGAN VENDING SERVICE  
Chicago, Ill.

M & S VENDING  
Minot, N.D.

PENNSYLVANIA DIST.  
Tipton, Pa.

VASCO VENDING  
Brooklyn, N.Y.

THE VENDO CO.  
Los Angeles, Cal.

THE VENDO CO.  
Atlanta, Ga.

THE VENDO CO.  
Elk Grove Village, Ill.

THE VENDO CO.  
Stoneham, Mass.

THE VENDO CO.  
Melvindale, Mich.

THE VENDO CO.  
Bellmawr, N.J.

THE VENDO CO.  
Hasbrouck Heights, N.J.

THE VENDO CO.  
Charlotte, N.C.

THE VENDO CO.  
Dallas, Tex.

VICTOR CONTE SALES INC.  
Utica, N.Y.

Golfers spend \$2<sup>3</sup>/<sub>4</sub> billions annually.  
You don't have to wind golf balls  
for a share of the market:  
All you need is hustle!

There are over 10,000 golf courses in the U.S.,  
plus 15,000 driving ranges and pitch-and-putts.  
Add it up.

That's 25,000 potential locations for the Golf IQ.

The Golf IQ Package puts a 1600 question film  
in your IQ Computer and adds a special Golf  
IQ lid.

Questions are professionally formulated, illustrations  
carefully prepared and the lid is Bent-grass  
Green.

\$2,750,000,000 is a lot of green.

We'll help you hustle.

Call or write:

NUTTING INDUSTRIES, LTD.  
3404 North Holton Street  
Milwaukee, Wisconsin 53212  
TEL: 414 332-8260

# U.S. Jobbers & Distributors Listed By States

\*Branch Offices

## ALABAMA

### BIRMINGHAM VENDING CO.

540 Second Ave. N.  
Birmingham 35204  
324-7526  
Max Hurvich & Albert Toronto, partners  
(All Charm, All-Tech, Automatic, Auto Photo, Chicoin, Cointronics, Fischer, Gottlieb, Leaf Brands, North-western.)

### FRANCO DISTRIBUTING CO., INC.

24 North Perry St.  
Montgomery 36104  
263-6463  
Rubin A. Franco, president  
(All-Tech, Brunswick, Chicoin, Gottlieb, Midway, Rock-Ola, U.S. Billiards, Williams-United.)

### \*HERMITAGE MUSIC

1631 First Ave. N.  
Birmingham 35203  
Jack Williams, manager.  
(All-Tech, American Shuffleboard, Beaver Vendors, Rowe, U.S. Billiards.)

### JEFFERSON MUSIC CO.

716 N. 19th St.  
Birmingham 35203

## ALASKA

### ALASKA MUSIC CO.

815 2nd Ave. P.O. Box 1234  
Fairbanks 99701  
456-4055  
Dan Thompson, president  
George Thompson, vice president  
(Nutting Assoc.)

## ARIZONA

### ARIZONA AMUSEMENT & VENDING

848 N. Fourth Ave.  
Tucson 85705

### GARRISON SALES CO.

2911 West Fairmount Ave.  
Phoenix 85017  
Stan Beasley, president  
(Gottlieb, Rowe.)

### GILA MUSIC CO.

406 Main St.  
Safford 95546

### \*STRUVE DISTRIBUTING CO.

1900 East McDowell Rd.  
Phoenix 85003  
(Nutting Assoc., Seeburg, U.S. Billiards, Williams-United.)

### VALIANT AMUSEMENT

3129 E. McDowell St.  
Phoenix 85008  
John Nowlin  
(Brunswick)

### VALLEY VENDORS CORP.

1145 W. Hilton Ave.  
Phoenix 85003  
258-8581  
Joel Kaufman, president  
(Jobber)

## ARKANSAS

### BRUNSWICK BILLIARD SUPPLY OF ARKANSAS

2681 Pike Ave.  
No. Little Rock 72114  
Lew Dellinger  
(Brunswick)

### GODWIN DISTRIBUTING CO., INC.

2116 W. 38th St.  
North Little Rock 72118  
Lester Godwin, president  
(Wurlitzer)

### JACK'S AMUSEMENT

Box 598  
Hampton  
(Gottlieb, United Billiards.)

### WILCOX AMUSEMENT CO., INC.

318 West 2nd St.  
Pine Bluff 7,601  
G. Tim Massanelli, president  
(American Shuffleboard)

## CALIFORNIA

### ADVANCE AUTOMATIC SALES CO.

1350 Howard St.  
San Francisco 94103  
431-1750  
Lou Wolcher, president  
C.N. McMurdie, vice president and general manager  
C.R. Klein, F.C. Robertson, DeLoss Osborn, Richard Rice, sales representatives  
(Brunswick, Chicoin, Gottlieb, Lektro-Vend, Midway, Seeburg, U.S. Automatic, Valley, Williams-United.)

### AMERICAN SHUFFLEBOARD SALES CO.

1423 S. Western Ave.  
Los Angeles  
733-3724  
Johnny Weiss, president  
(American Shuffleboard)

### \*AMERICAN SHUFFLEBOARD SALES CO.

1646 E. 12th St.  
Oakland 94606  
535-0100  
Leslie Lystad, president  
Thomas Elder, vice president and general manager  
(All-Tech, American, Brunswick, Chetek, Diversified, Federal, Fischer, Frederick, Gotham, Murrey, Rock-Ola, Rowe, Valley, Willys.)

### AMERICAN COIN AMUSEMENT SALES & SERVICE

2230 East 14th St.  
Oakland 94606  
Henry Leyser, president  
George Muraoka, vice president  
Harry Burd, vice president  
Francis Carneior, sec-treasurer  
(Kansai, NSM, SEGA.)

### AMERICAN COIN AMUSEMENT SALES & SERVICE

2891 West Pico Blvd.  
Los Angeles 90006

### BADGER SALES CO.

2251 W. Pico Blvd.  
Los Angeles 90007  
Bill Happell, president  
(jobber)

### CIRCLE INTERNATIONAL CO.

2401 South Hill St.  
Los Angeles 90007  
Dean McMurdie, president  
Ken Smith, vice president  
(All-Tech, Bally, Fischer, Rowe, U.S. Automatic.)

### DARVIN CORP.

2809 W. Pico Blvd.  
Los Angeles 90006  
David Solish, president  
(All-Tech, Brunswick, Wurlitzer.)

### EASTERN NOVELTY CO.

2939 E. 11th St.  
Los Angeles  
269-5979  
Sol Mollengarden, manager  
(billiard accessories)

### PAUL LAYMON, INC.

1429-31 W. Pico Blvd.  
Los Angeles 90015  
RI-9-7351  
(Brunswick)

### PACIFIC COIN MACHINE DIST., INC.

P.O. Box 3351  
Modesto 95353  
Bud Patton, president  
(Rock-Ola)

### PORTALE AUTOMATIC SALES

1319 West Pico Blvd.  
Los Angeles 90015  
746-1191  
Robert Portale, president  
(Chicoin, Gottlieb, Nutting, Rock-Ola, United Billiards.)

### C.A. ROBINSON CO., INC.

2301 West Pico Blvd.  
Los Angeles  
385-7318  
Al Bettelman, president  
Malcolm Hall  
Henry Tronick  
(Bally, Cointronics, Midway, Valley.)

### ROVENDCO INTERNATIONAL

1400 Minnesota St.  
San Francisco 94107  
285-0300  
W.B. Gaul, manager  
(All-Tech, Gottlieb, Rowe.)

### STRUVE DISTRIBUTING CO.

1403 W. Pico Blvd.  
Los Angeles 90015  
748-8641  
Bud Lurie, manager  
(Seeburg, U.S. Billiards, Williams-United.)

### THE WURLITZER CO.

2920 W. Pico Blvd.  
Los Angeles 90006  
737-2521  
Anthony (Bart) Bartholomew, general manager  
(Brunswick, Wurlitzer.)

### THE WURLITZER CO.

154 S. Van Ness Ave.  
San Francisco 94703  
863-7900  
Amie Addy  
(Wurlitzer)

### THE VENDO CO.

7101 East Telegraph Rd.  
Los Angeles 90022  
Lawrence Kice  
(Cameron)

## COLORADO

### DIAMOND DIST. CO.

2830 W. 9th Ave.  
Denver 80204  
534-6308  
Phillip Glover, manager  
(Gottlieb, Rowe.)

### DRACO SALES CO.

759 Valjejo St.  
Denver 80204  
892-7063  
M.J. Savio  
(Brunswick, Wurlitzer.)

### MAR-MAC SALES & SERVICE CO.

3501 N. El Paso  
Colorado Springs  
(Brunswick)

### MOUNTAIN DISTRIBUTORS

3630 Downing St.  
Denver 80205  
222-8518  
Peter Geritz, owner  
Frank Negri, sales manager  
Paul Vidmar, service manager  
(American, Automatic, Chicoin, Cornelius, Gottlieb, Rock-Ola, Valley, Universal, Westinghouse.)

### \*STRUVE DIST. CO., INC. OF COLO.

50 Rio Grande Blvd.  
Denver 80223  
(Nutting Assoc. Seeburg, U.S. Billiards, Williams-United.)

## CONNECTICUT

### \*ATLANTIC CONN. CORP.

171 Park Ave.  
East Hartford 06108  
289-4386  
Max Perlman, general manager  
Alfred Stellaccio, office manager  
Norman Bower, vending manager  
(All-Tech, Gottlieb, Seeburg, Valley, Williams-United.)

### COUNTY BILLIARD SUPPLY

1838 Stratford Ave.  
Bridgeport 06607  
F. Hanko, general manager  
(Brunswick)

### WURLITZER DIST. CORP.

360 Tolland St.  
East Hartford 06108  
289-6017  
Ben Gordon, manager  
(United Billiards, Wurlitzer.)

## FLORIDA

### ALL-COIN AMUSEMENTS CO., INC.

7401 NW Miami Place  
Miami 33150  
Joseph Mangone, president  
(Gottlieb)

### BUSH INTERNATIONAL, INC.

286 N.W. 29th St.  
Miami 33137  
633-2608  
O.R. Truppman, vice president  
George Klersey, staff coordinator  
Felix Whatley, manager  
Sam Hartman, comptroller  
(All-Tech, Chicoin, Cointronics, Rowe.)

### BUSH INTERNATIONAL, INC.

60 Riverside Dr.  
Jacksonville 32202  
356-0256

### BUSH INTERNATIONAL, INC.

1723 West Cypress St.  
Tampa 33606  
251-1801

### \*ELI ROSS DISTRIBUTORS, INC.

807 Kipp St.  
Jacksonville 32207  
Eli Ross, president  
(Allied Leisure, Cointronics, Rock-Ola, U.S. Billiards.)

### ELI ROSS DISTRIBUTORS, INC.

852 N.W. 71st St.  
Miami 33150

### F.A.B. DISTRIBUTING CO., INC.

3927 Navy Blvd.  
Pensacola 32507  
455-1341  
F.A. Blalock, president  
F. Albert Blalock, vice president  
(American, Fischer, United Billiards, U.S. Billiards, Wurlitzer.)

### FLORIDA MUSIC & VENDING

310 Riverside Ave.  
Jacksonville  
(Seeburg, Williams-United.)

### SOUTH ATLANTIC DIST. CO.

1100 NW 163rd Dr.  
Miami 33169  
621-1415  
Ted Lowe, manager  
Bill Morrow, controller  
(Seeburg, United Billiards, Williams-United.)

### SOUTH ATLANTIC DIST. CO.

4635 Highway Ave.  
Jacksonville 32205  
387-7501  
Jack McKinney, manager

### \*SOUTHERN MUSIC DIST. CO., INC.

2465 Harper St.  
Jacksonville 32204  
356-1337  
J.T. Elkins, manager  
(Brunswick, Wurlitzer.)

### SOUTHERN MUSIC DIST. CO., INC.

503 W. Central Blvd.  
Orlando 32801  
423-2261  
Ron Rood, president  
H.F. Tripp, manager



Exclusive Distributors: **Rowe** MUSIC SYSTEMS & VENDING MACHINES

Exports The  
In Music, Games



World's Needs  
and Vending

**Fischer - Bally - All Tech - Gottlieb**

offices: Los Angeles • Honolulu

2401 S. Hill St., Los Angeles, Calif. 90007

Cable: CIRCLEINT

Phone: A.C. 213 — 749-7405

# U.S. Jobbers & Distributors Listed By States

## GEORGIA

**GREATER SOUTHERN DIST. CO.**  
321 Edgewood Ave., S.E.  
Atlanta 30312  
523-3456  
Morris Pihl, president  
(All-Tech, Chicoin, Fischer, Gottlieb, Midway, Rock-Ola, U.S. Billiards.)

**PEACH STATE MUSIC CO.**  
148 State St. P.O. Box 4371  
Macon 31208  
743-1588  
W.N. Hawes, president  
A.J. Hawkins, vice president  
(Bally, Brunswick, Chicoin, Fischer, Gottlieb, Rowe.)

**PEACH STATE DIST. CO.**  
1040 Boulevard, S.E.  
Atlanta 30312  
622-4401

**SOUTH ATLANTIC DISTRIBUTING CO.**  
763 Trabert Ave. NW  
Atlanta 30318  
351-2380  
Joe Fitzpatrick, president  
Charles Cooper, treasurer  
Jack Lovelady, representative  
(Seeburg, Williams-United.)

**VARIETY DISTRIBUTING**  
585 Grant St. SE  
Atlanta 30312  
(Nutting Assoc.)

**THE VENDO CO.**  
452 Armour Circle N.E.  
Atlanta 30324  
(Cameron)

**THE WURLITZER DIST. CORP.**  
1761 Tully Circle N.E.  
Atlanta 30329  
633-0303  
Bob Bender, manager  
(Allied, Automatic, Gottlieb, Midway, Moyer Diebel, Universal, Wurlitzer.)

## HAWAII

**AUTOMATIC VENDING MACHINE CO.**  
P.O. Box 186 712 California Ave.  
Wahiawa, Hawaii 96786  
Charles Tashima, president  
Joe Inouye, manager  
Samuel Izumi, service manager  
(American, Cointronics, Gottlieb, Midway, Watling.)

**CIRCLE INTERNATIONAL CO.**  
P.O. Box 315  
Honolulu 96809  
Jose Guzman, controller  
Francis Thompson, salesman  
Furd Glover, salesman  
(All-Tech, Bally, Fischer, Rowe, U.S. Automatic.)

**NATIONAL AMUSEMENT, INC.**  
3014 Wai'ala'e Ave.  
Honolulu 96816  
732-1877  
Lorin Kushiya, president  
Alvin Kushiya, vice president  
Gerald Kushiya, treasurer  
Tadashi Hashimoto, secretary  
James Cabbab, manager  
(Automatic, Macon, Panasonic, Wurlitzer.)

**HAWAIIAN AMUSEMENTS CO.**  
905 Ahnoa St.  
Honolulu 96819  
(SEGA)

**\*NATIONAL AMUSEMENT, INC.**  
340 N. Market St.  
Wailuku, Maui, Hawaii  
35-455

## ILLINOIS

**AMERICAN SHUFFLEBOARD SALES CO.**  
101 S. Goodwin St.  
Peoria  
Lou Osterman  
(American Shuffleboard)

**ATLAS MUSIC CO.**  
2122 N. Western Ave.  
Chicago 60647  
276-5005  
Ed Ginsburg  
Sam Gersh  
Joe Kline  
Sam Kolber  
Stanley Levin  
Bill Phillips  
Robert Fabian  
Joe Klykun  
(Bally, Rowe, Tele-Norm.)

**EMPIRE DIST., INC.**  
120 S. Sangamon  
Chicago 60607  
421-5200  
Gil Kitt, president  
Joe Robbins, vice president  
(Bally, Chicoin, Gottlieb, Midway, Nutting Assoc., Rock-Ola, SEGA.)

**MID-WEST DISTRIBUTING CO.**  
212 N. Madison St.  
Rockford 61104  
962-8887  
William Morris, president  
Reno Sandona, vice president  
(jobber)

**LOGAN VENDING SERVICE**  
1850 W. Division St.  
Chicago  
Jack Nelson  
Dick Boylan  
(Cameron)

**NATIONAL COIN MACHINE EXCHANGE**  
1411-13 Diversey Blvd.  
Chicago 60614  
BU-1-8211  
J.A. Schwartz, partner  
Morton Levinson, sales manager  
(Chicoin, Gottlieb, Valley, Wurlitzer.)

**PURVEYOR DISTRIBUTING CO.**  
4322-24 North Western Ave.  
Chicago 60618  
588-1814  
Herbert Perkins  
Shirlee Ann Byrd  
(American Shuffleboard)

**SPECIALTY SALES CORP. OF AMERICA**  
2606 W. Peterson Ave.  
Chicago  
764-5025  
Ron Kaghan  
Larry Kaghan  
(Nutting Ind., NSM, United Billiards.)

**THE VENDO CO.**  
2201 Arthur Ave.  
Elk Grove Village 60007  
John Kensey Jr., general manager  
(Cameron)

**WORLD WIDE DISTRIBUTORS, INC.**  
2730 W. Fullerton Ave.  
Chicago 60647  
384-2300  
Nathan Feinstein, president  
Irving Owitz, vice president, vending  
Harold Schwartz, vice president, phonographs  
Fred Skor, vice president, games  
(Brunswick, Candy Mat, Choice Vend, Irving Kaye, Lekro-Vend, Murrey, Omnivend, Seeburg, Steel-made, U.S. Automatic, Valley, Williams-United.)

## INDIANA

**Jack Eiser Sales Co.**  
820 Schick St.  
Fort Wayne 46803  
422-8615  
Jack Eiser, owner  
(jobber)

**\*GATEWAY CO-OPERATIVE DIST. CO.**  
1252 Division St.  
Evansville 47714  
424-6290  
L.W. Cruze, manager  
(Wurlitzer)

**LEW JONES DISTRIBUTING CO., INC.**  
1311 N. Capitol Ave.  
Indianapolis 46202  
635-1593  
Lewis Jones, president  
(Chicoin, Gottlieb, Irving Kaye, Wurlitzer.)

**J & J DISTRIBUTORS, INC.**  
1661 W. 16th St.  
Indianapolis 46202  
634-3571  
Joseph Flynn, president  
John Stockdale, secretary-treasurer  
(Bally, Brunswick, Chicoin, Fischer, Gottlieb, Irving Kaye, Midway, Moyer Diebel, Rowe, Valley, Victor, Williams-United.)

**MODERN VENDING CO., INC.**  
423 N. Alabama St.  
Indianapolis 46204  
634-8468  
Al Calderon, president  
Elliott Nelson, vice president  
(Bally, Chicoin, Seeburg, Valley, Williams-United.)

## IOWA

**PHILIPS MOSS & CO.**  
1420 Locust St.  
Des Moines 50309  
Philip Moss, president  
(American Shuffleboard, Chicoin, Fischer, Midway, Seeburg, Williams-United.)

## KANSAS

**BIRD MUSIC DISTRIBUTORS, INC.**  
124-126 Poyntz Ave.  
Manhattan 66503  
778-5221  
A.L. Ptacek, president  
(Rock-Ola, United Billiards.)

**UNITED DISTRIBUTORS, INC.**  
902 W. Second St., Box 1995  
Wichita 67203  
264-6111  
M.M. Hammer  
M.Y. Blum  
Mark Blum Jr.  
(Automatic, Bally, Cointronics, Midway, Tape-Athon, Universal, Valley, Williams-United, Wurlitzer.)

## KENTUCKY

**CO-OPERATIVE DIST. CO.**  
221 E. Market St.  
Louisville 40202  
583-6173  
Bernard Jacobs, manager  
(Wurlitzer.)

**WAGG SERVICE-SOUTHERN MUSIC CO.**  
735 S. Brook St.  
Louisville 40201  
Kenny Young, general manager

**S.L. STIEBEL CO.**  
635 W. Main St.  
Louisville 40202  
583-2813  
Walter Waldman, president  
Harvey Weingarten, secretary-treasurer  
(Automatic, Chicoin, Fischer, Gottlieb, Midway, Rock-Ola, Universal.)

SERVICE is MORE than a word at  
**WORLD WIDE**  
...YOUR ONE-STOP SUPERMARKET  
for GAMES - MUSIC - VENDING

WORLD WIDE'S more  
than a quarter century  
of export experience  
is your assurance  
that you can buy  
with confidence. Every  
machine location-proved  
with our unique  
"Continuous Play-Testing."

WE SHIP  
EVERYWHERE!  
ARCADE  
PHONOGRAPHS  
AMUSEMENT GUNS  
BOWLERS • VENDERS  
SHUFFLE GAMES  
FLIPPER GAMES  
• THOROUGHLY RE-  
CONDITIONED OR  
AS IS—CLEAN,  
COMPLETE  
• PROTECTIVE  
PACKING

DISTRIBUTORS FOR: SEEBURG • UNITED • WILLIAMS

We carry the most complete line of Phonographs, Games, Arcade  
and Vending Equipment. Write for Complete list!



**WORLD WIDE distributors**  
2730 WEST FULLERTON AVE., CHICAGO 47, ILL.  
EVerglade 4-2300 CABLE: GAMES - CHICAGO

## THE OLDEST and LARGEST DISTRIBUTOR

### ON THE PACIFIC COAST

Exclusive Distributors for:

SEEBURG CORP.  
GOTTLIEB MFG. CO.  
U. S. BILLIARDS  
BALLY

VALLY POOL TABLES  
CHICAGO COIN  
U.S. AUTOMATIC SALES, INC.

WILLIAMS MFG. CO.  
MIDWAY MFG. CO.  
UNITED BILLIARDS  
ELECTRA VEND

We have substantial inventories at all times of used:

✓ PHONOGRAPHS                      ✓ GAMES                      ✓ BOWLERS  
✓ SHUFFLE ALLEYS                      ✓ ARCADE EQUIPMENT

Write or Wire for Information:

Cable Address: PINGAME

Phone: HEmlock 1-1750

**ADVANCE AUTOMATIC SALES CO.**  
1350 HOWARD STREET, SAN FRANCISCO, CALIF. (415) HE 1-1750

# U.S. Jobbers & Distributors Listed By States

## LOUISIANA

### A.M.A. DISTRIBUTORS, INC.

1711 St. Charles Ave.  
New Orleans 70130  
529-2315  
Robert Nims, president  
John Asproditis, sales manager  
James Aucdin, parts department manager  
(Automatic, Brunswick, Coffee-Mat, Fischer, Midway, Rock-Ola.)

### BUSH INTERNATIONAL

1601 S. Gayoso  
New Orleans 70125  
822-9000  
(All-Tech, Chicoin, Cointronics, Rowe.)

### CROSSE-DUNHAM & CO.

225 Wright Blvd.  
Gretna 70053  
David Joyce  
jobber

### NEW ORLEANS NOVELTY

1055 Dryades St.  
New Orleans 70113  
529-7321  
Louis Boasberg, general manager  
Ralph Bosworth, sales manager  
Joseph Isaacson, head engineer  
(Bally, Chicoin, Gottlieb, Nutting Assoc., Williams-United, SEGA)

### OPERATORS SALES, INC.

4122 Washington Ave.  
New Orleans 70125  
John Elms Jr., president  
Lawrence Lagarde, secretary-treasurer  
Hubert Bordelon, executive vice president  
(Seeburg, Valley, Williams-United.)

### WURLITZER DIST. CORP.

832 Baronne St.  
New Orleans 70113  
523-4734  
R.G. DePuy  
(United Billiards, Wurlitzer.)

### S & H DISTRIBUTING CO.

1550 Bolinger St.  
Shreveport 71103  
422-1642  
Tom Hughes, manager  
(Rowe.)

### SOUTH ATLANTIC DIST. CO.

191 Orchard Rd.  
New Orleans 70123  
737-6141  
Ernest Phillips, representative

## MARYLAND

### ADVANCE VENDING

829 Nursery Road  
Linthicum  
David Rubenstein, manager  
jobber

### EASTERN DISTRIBUTORS, INC.

1812 Worcester St.  
Baltimore 21230  
(Seeburg)

### GENERAL VENDING SALES CORP.

245 W. Biddle St.  
Baltimore 21201  
837-4119  
Harry Hoffman, president  
George Goldman, vice president  
Arnold Kaminkow, controller  
Irving Block, service manager  
(Brunswick, Chicoin, Cointronics, Fischer, Gotham, Gottlieb, Klopp, Nutting Assoc., Rock-Ola, Standard.)

### MAR-MATIC SALES CO., INC.

1140 E. Cold Spring Lane  
Baltimore 21212  
Maurice Sykes, president  
Joseph Barranco, secretary-treasurer  
(Jennings)

### STATE SALES & SERVICE CORP.

1825 Guilford Ave.  
Baltimore 21202  
Samuel Weisman, president  
David Koenigsberg, secretary-treasurer  
(Bally, Colorsonics, Irving Kaye, Midway, Moyer Diebel, Tape-Athon, Universal Venders, Vendo, Wurlitzer.)

## MASSACHUSETTS

### EASTERN BILLIARD SUPPLY

508 Medford St.  
Somerville 02143  
Paul Luchessi, general manager  
(Brunswick)

### COFFEEMAT INC.

24 Bridge St.  
Watertown 02172  
(Nutting Assoc.)

### GLOBE AUTOMATIC VENDING MACHINE CO., INC.

378 Granite St.  
Quincy 02169  
Tony Grazio, president  
Nelson Kady, manager  
(Rock-Ola)

### TRIMOUNT AUTOMATIC SALES CORP.

888 Rear Providence Hwy.  
Dedham 02026  
Irwin Margold, vice president  
Marshall Caras, general manager  
(All-Tech, Bally, Brunswick, Chicoin, Fischer, Gottlieb, Irving Kaye, Rowe, Valley, SEGA)

### W.S. DISTRIBUTING CO.

40 Teed Dr.  
Randolph  
William Schwartz, president  
Bob Green, general manager  
(Bally, Irving, Kaye, Seeburg, Williams-United)

### WURLITZER DIST. CORP.

70 Winchester St.  
Newton Highlands 02161  
527-0002  
Ralph Lackey, general manager  
(Wurlitzer)

### THE VENDO CO.

16 Spencer St.  
Stoneham 02180  
(Cameron)

## MICHIGAN

### ANGOTT DIST. CO., INC.

2616 Puritan Ave.  
Detroit 48238  
864-0773  
Carl Angott Sr., president  
Carl Angott Jr., vice president  
William Angott, secretary-treasurer  
(Automatic, Universal Venders, Wurlitzer)

### EMPIRE DIST. INC.

8201 Fenkell Ave.  
Detroit 48238  
341-5800  
Gilbert Kitt, president  
James Frye, manager  
American, Automatic, Avenco, Bally, Chicoin, Fischer, Gottlieb, Midway, Rock-Ola, Valley, Westinghouse.

### MARTIN & SNYDER CO., INC.

8880 Hubbell  
Detroit 48228  
272-7800  
G.A. Snyder, president  
F.J. Martin, executive vice president  
J.W. Hamilton, vice president, sales  
Hamilton, Ideal, Irving Kaye, Magic Chef, Moyer-Diebel, Northwestern, Seeburg, Standard, Steelmade, United, Universal Vendors, U.S. Automatic, Valley, Williams.

### MARTIN & SNYDER CO., INC.

1123 S. Division St.  
Grand Rapids 49507

### MILLER DISTRIBUTING CO.

3767 E. 28th St.  
Grand Rapids 49508  
949-2030  
Donald Miller, president  
Art Hebert, vice president  
Jerry Van Gessel, secretary-treasurer  
Allied, All-Tech, American, Brunswick, Chicoin, Gottlieb, Leaf, Litton, Nutting, Oak, Rowe, Valley, Victor.

### MILLER DIST. CO.

310 Livernois  
Ferndale

## MINNESOTA

### ADVANCE MUSIC CO., INC.

7650 Wayzata Blvd.  
Minneapolis 55426  
544-5050  
Norman Pink  
Amos Heilicher  
Daniel Heilicher  
Auto Photo, Rock-Ola, U.S. Billiards.

### LIEBERMAN MUSIC CO.

9549 Penn Ave. S.  
Minneapolis 55431  
888-5521  
All-Tech, Fischer, Gottlieb, Midway, Nutting Assoc., Seeburg, Williams-United.

### VIKING VENDING CO. (DIV. OF LIEBERMAN)

9549 Penn Ave. S.  
Minneapolis 55431  
Lektro-Bend, Seeburg Bend, Tommy Lift Gate, U.S. Automatic, Universal.

### K.C. SALES AND SERVICE

1926 University Ave.  
St. Paul 55104  
645-9184  
Clare Wesely, president  
Ed Demars, sales  
Chicoin, Irving Kaye, Litton, Rowe, U.S. Automatic, Victor.

# CHICAGO COIN'S DEPENDABLE MONEY MAKERS FOR ALL TYPES OF LOCATIONS!

1-, 2- AND 4-PLAYER PIN GAMES  
BALL AND PUCK BOWLERS • RIFLE GALLERIES • ARCADE GAMES



## SUPER CIRCUS

### RIFLE GALLERY

- NEW SOUND SYSTEM
- DOUBLE DEPTH ILLUSION

FABULOUS!

## SPEEDWAY

- REALISTIC DRIVING
- REALISTIC RACING CAR SOUNDS!

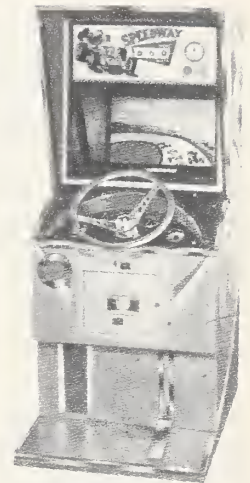

MORE  
PLAY...  
PROFITS!

## ESQUIRE

### 6-PLAYER PUCK BOWLER

WITH NEW  
"MOD-LOOK"  
CABINET



6-WAYS  
TO PLAY

Mfrs.  
of  
PROVEN  
PROFIT MAKERS  
Since  
1931

UNIQUE!

## COWBOY

### 4-PLAYER PIN GAME

"TEXAS SIZE" 5-in.  
FLIPPERS

- BONUS SCORE MEMORY UNIT
- MUSICAL SOUND EFFECTS



BIG FLIPPER—2 PLAYER PIN GAME

CHICAGO COIN MACHINE DIV.

# CHICAGO DYNAMIC INDUSTRIES, INC.

1725 W. DIVERSEY BLVD. CHICAGO, ILLINOIS 60614

# RUNYON

SERVING THE OPERATOR ...  
SERVING THE INDUSTRY ...  
ALWAYS WITH A SMILE!

Distributors for the finest  
Coin-Operated Equipment:  
**MUSIC AMUSEMENT  
FULL LINE VENDING  
POOL TABLES**



**The Rowe AMI TRIMOUNT  
Phonograph  
Stereo-Round Sound  
Breathtaking Design**



**The Rowe AMI PHONOVUE  
The sensational companion  
piece to the Music Miracle  
that's making location history!**

**Rowe FULL-LINE Vendors  
A Vending Machine for  
every location!**

**TOP AMUSEMENT LINES!**

**BALLY  
IRVING KAYE  
WILLIAMS  
MIDWAY  
GOTTLIEB  
NUTTING ASSOCIATES  
UNITED**

**ONE-STOP SHOPPING  
AT RUNYON!**

SHUFFLES — PINS — GUNS — QUIZ GAMES—  
PARTS & SERVICE — RECORD DEPT — SHOPS  
— SPRAYROOMS — LUXURIOUS SHOWROOMS —  
VISIT US!

**RUNYON SALES CO. INC.**

U.S. Route 22, Fadam Road, Springfield, N.J.  
Tel.: DRexel 6-8720

593 Tenth Avenue, New York, N.Y.  
LOngacre 4-1900

## WE ARE EXPORT DISTRIBUTORS OF:

Bally — Bingos & Slot Machines  
Williams—Gottlieb—Chicago Coin  
FLIPPERS

INTERNATIONAL MUTOSCOPE  
Photomatic and  
Arcade Equipment

PHONOGRAPHS  
AMI — Seeburg — Rock-Ola

**CROSSE-DUNHAM & CO.**  
225 Wright Blvd. "F"  
Gretna, La. 70053, Call: 367-4365  
Cable Address: Crossedunham



**Active's**  
THE CHOICE FOR  
the Lowest  
Prices  
and  
Best Equipment  
ALWAYS

Exclusive Gottlieb, Rock-Ola, Fischer  
and Chicago Coin Distributor for Eastern  
Pennsylvania, South Jersey and Delaware.

**ACTIVE Amusement Machines Co.**  
666 No. Broad Street, Phila. 30, Pa. POplar 9-4495  
1101 Pittston Ave., Scranton 5, Penna.

## WANTED — TO BUY

Arcade and Amusement Games  
**FOR SALE — FOR EXPORT**  
Bally Slots .....\$295 & up  
Mills Open Front,  
Like New.....\$285  
Mills HiTop ..... 125  
Jennings Galaxy ..... 285

Large Stock of Bally Bingos.  
Bally Parts for Export.

**Bally Distributing Company**  
390 E. 6th St. P.O. Box 7457  
Reno, Nevada 89502  
(702) 323-6157  
1524 South Western Avenue  
Las Vegas, Nev. (702) 385-3632

**REPRESENTING:  
ROCK-OLA  
GOTTLIEB  
CHICAGO COIN  
BRUNSWICK  
U.S. BILLIARDS**

**H.Z. Vending &  
Sales Company**  
1201-03-07 Douglas St  
Omaha, Nebr. Ph. 341-1121

For the finest in Shuffles  
and Bowlers, insist on

**"United"**  
Now Delivering  
**LAGUNA**

**BANNER SPECIALTY CO.**

1213 N. 5th St. Phila., Pa. 215-236-5000  
1508 Fifth Ave. Pgh., Pa. 412-471-1373  
Exclusive Factory Authorized Distributor  
for Penna., New Jersey, Delaware

# U.S. Jobbers & Distributors

## Listed By States

### NEW JERSEY

• **ATLANTIC NEW JERSEY CORP.**  
730 Division St.  
Elizabeth 07201  
289-8500  
Oscar Parkoff, president  
Paul Cantor, sales manager  
All-Tech, Gottlieb, Magic Chef, Seeburg, United, Valley,  
Williams.

### BETSON ENTERPRISES

3726 Tonnelle Ave.  
North Bergen 07307  
UN-4-2424  
Bert Betti, president  
Louis Avoglia, service manager  
Jerry Gordon, sales director  
Howard Rubin, field sales manager  
Joseph Rubin, field sales manager  
Joseph Cirillo, comptroller  
All-Tech, American Shuffleboard, Automatic, Chicoin,  
Cointronics, Fischer, Midway, Rock-Ola.

### IRVING MORRIS, INC.

145 Frelinghuysen Ave.  
Newark 07114  
243-4300  
Irv Morris, president  
Irwin Rosenfield, manager  
Gottlieb, Pin Games, United Billiards.

### RUNYON SALES CO.

U.S. Route 22 & Fadam Rd.  
Springfield 07081  
DR-6-8720  
Abe Green, president  
Ed Berg, general manager  
Bally, Irving Kaye, Nutting Assoc., Rowe, U.S. Auto-  
matic.

### SEACOAST DISTRIBUTORS

1200 North Ave.  
Elizabeth 07201  
248-3524  
Dave Stern, president  
Rock-Ola

### SUGERMAN INTERNATIONAL

140 Central Ave.  
Hillside 07205  
923-6430  
Myron Sugerman, president  
Barry Feinblatt, vice president  
Hans Vandendoop, vice president  
Edward Ryblewski, parts division manager  
Phonographic

### NEW MEXICO

### BORDER-SUNSHINE NOVELTY

2919 Fourth St. NW  
Albuquerque 87107  
344-1626  
John Snodgrass, President  
Jobber

### HARPER'S CONSOLIDATED MUSIC CO., INC.

1062 N. Seventh St. Box 86  
Las Cruces 88001  
524-4175  
Al Harper, President  
Wurlitzer

### NEW YORK

### ACE-HI Distributors

1286 Electric Ave.  
Lackawanna 14218  
822-3800  
William Eagan, sales representative  
David Vystup, parts manager  
Rita Croce, office manager  
Rock-Ola

### A-1 RECREATIONAL EQUIPMENT

Freeport, L.I.  
American Shuffleboard, U.S. Billiards

### ACTIVE AUTOMATIC SALES CORP.

391 Coleridge Rd.  
Rockville Centre 11570  
Hal Zimmerman, president  
C.S. Zimmerman, vice president  
Al Fischer, Urban, Rene Pierre.

### ADVANCE DIST., INC.

601 Thompson Rd. N.  
Syracuse 13211  
Maurie Lerner, president  
Automatic Prod., Rock-Ola.

### AMERICAN VENDING CO.

3000 Coney Island Ave.  
Brooklyn  
Milt Green  
Jobber

### ATLANTIC NEW YORK CORP.

843 Tenth Ave.  
New York 10019  
PL-7-3140  
Meyer Parkoff, president  
Murray Kaye, sales manager  
All-Tech, Gottlieb, Magic Chef, Seeburg, United, Valley,  
Williams.

### R.H. BELAM, INC.

51 Madison Ave.  
New York 10010  
MU-9-5633  
Vic Haim  
Morris Nahum  
Exporters

### SANDLER VENDING CO.

236 Girard Ave. North  
Minneapolis 55405  
377-1140  
Irving Sandler, chairman  
Warren Sandler, president  
Hy Sandler, secretary, sales manager  
American Shuffleboard, Automatic, Bally, Nutting Ind.,  
Valley, Wurlitzer.

### MISSOURI

### ADVANCE DIST. CO., INC.

2820 North Grand Blvd.  
St. Louis 63107  
Charles Kagels, president  
Arnold Edmonds, general manager  
American Shuffleboard, Auto Photo, Rowe, U.S. Bill-  
iards.

### BRANDT DIST. CO., INC.

1809-11 Olive St.  
St. Louis 63103  
421-3413  
Peter Brandt, president  
Norman March, general manager  
Wurlitzer

### CENTRAL DISTRIBUTORS

2315 Olive St.  
St. Louis 63103  
SEGA

### L & R DISTRIBUTING INC.

1901 Delmar Blvd.  
St. Louis 63103  
Lou Rubin  
Seeburg

### MORRIS NOVELTY CO.

St. Louis

### MUSICAL SALES INC.

2920 Locust St.  
St. Louis 63103  
535-4310  
Joseph McCormick, president  
Sam Massaro, sales manager  
Fischer, Rock-Ola, Valley.

### MIDWEST AMUSEMENT DIST. INC.

10407 Liberty St.  
St. Louis County  
Peter Entringer, president  
423-1100  
Brunswick

### SEEBURG CENTRAL DIST. CO.

512 E. 12th Ave.  
N. Kansas City  
Seeburg

### W.B. MUSIC CO., INC.

2900 Main St.  
Kansas City 64108  
Harry Silverberg, president  
Jerome Becker, sales manager  
All-Tech, Bally, Brunswick, Chicoin, Fischer, Gottlieb,  
Midway, Rowe.

### MONTANA

### H.B. BRINCK

825-827 E. Front St.  
Butte 59701  
Harry Brinck, president  
Rock-Ola

### NEBRASKA

### CENTRAL DIST. CO.

1209 Douglas St.  
Omaha 68102  
346-5200  
L. Singer, manager  
SEGA, Wurlitzer

### COIN-A-MATIC, INC.

1208 Farnam St.  
Omaha 68102  
341-0425  
Howard Ellis, president  
American Shuffleboard

### H.Z. VENDING & SALES CO., INC.

1205 Douglas St.  
Omaha 68102  
341-1121  
Hymie Zorinsky, president  
Brunswick, Chicoin, Gottlieb, Rock-Ola, U.S. Billiards.

### • PHILIP MOSS & CO.

309 N. 16th St.  
Omaha 68110  
346-3933

### NEW HAMPSHIRE

### TRI-STATE AMUSEMENT CO.

622 Elm St.  
Manchester 03101  
Ed Martell, president  
All-Tech, American Shuffleboard.

# U.S. Jobbers & Distributors Listed By States

**\*BILOTTA ENTERPRISES, INC.**  
388 Broadway  
Albany 12207  
Bob Catlin, manager

**BILOTTA ENTERPRISES, INC.**  
224 N. Main St.  
Newark 14513  
DE-1-1855  
John Bilotta, president  
Automatic Prod., Bally, Chicoin, Cointronics, Fischer,  
Gottlieb, Irving Kaye, Midway, Mutoscope, Nutting  
Ind., U.S. Billiards, Universal, Wurlitzer.

**VICTOR CONTE SALES, INC.**  
506 Nichols St.  
Utica 13501  
Vic Conte, president  
Cameron

## NEW YORK

**\*VICTOR CONTE SALES, INC.**  
1813 South Ave.  
Syracuse 13207

**DAVIS DISTRIBUTING CORP.**  
738 Erie Blvd. East  
Syracuse 13210  
475-1631  
Albert Wertheimer, president  
Henry Wertheimer, vice president, sales  
Robert Romig, secretary-treasurer  
Seeburg

**\*DAVIS DISTRIBUTING CORP.**  
1231 Main St.  
Buffalo 14209  
882-5500

**\*DAVIS DISTRIBUTING CORP.**  
56 N. Union St.  
Rochester 14607  
546-7848

**\*DAVIS DISTRIBUTING CORP.**  
1056 Broadway  
Albany 12204  
434-4151

**FLOWER CITY DISTRIBUTORS, INC.**  
389 Webster Ave.  
Rochester 14607  
654-8020  
Joe Grillo, president  
Ann Grillo, corp. secretary  
Automatic, Bally, Brad, Chicoin, Fischer, Gottlieb,  
Rock-Ola, U.S. Billiards, Williams.

**GRECO BROS. AMUSEMENT CO., INC.**  
P.O. Box G Main Street  
Glasco 12432  
246-8700  
Tom Greco, president  
Joe Greco, vice president  
John Greco, secretary  
Frank Greco, treasurer  
Midway, NSM, United Billiards.

**\*GRECO BROS. AMUSEMENT CO., INC.**  
1288 Broadway  
Albany 12204  
465-0228  
Jules Olshein, manager  
Midway, NSM, United Billiards, Vendo.

**LIPSKY DIST. CORP.**  
607 Tenth Ave.  
New York  
LO-3-4028  
Mrs. Bernice Lipsky, principal  
Jobber

**MOHAWK SKILL GAMES CO.**  
67 Swaggertown Rd.  
Scotia 12302  
377-2162  
Ogden Whitbeck, proprietor  
Jobber

**\*WHITBECK NOVELTY CO.**  
86 Snowden Ave.  
Schenectady 12302  
274-7549

**MIKE MUNVES CORP.**  
577 Tenth Ave.  
New York 10036  
279-6677  
Mike Munves, president  
Joe Munves, vice president  
Arcade equipment

**\*ECONOMY SUPPLY CORP.**  
579 Tenth Ave.  
New York 10036  
CH-4-8628

**MUSICAL DISTRIBUTORS CORP.**  
2714 Beverley Rd.  
Brooklyn 11226  
UL-6-7720  
Harold Kaufman, president

**\*MUSICAL DISTRIBUTORS CORP.**  
714 Tenth Ave.  
New York 10019  
JU-6-7782  
Candimat, Chicoin, Contronics, Ideal, Midway, Moyer,  
Diebel, United Billiards, Valley, Vendo, Westinghouse,  
Wurlitzer

**\*MUSICAL DIRECTORS CORP.**  
4170 Sunrise Highway  
Massapequa, L.I.

**NYACK SLATE CO.**  
112 Railroad Ave.  
Nyack 10960  
358-2464  
John Van Wyck, president  
Billiard supplies

**\*RUNYON SALES CO.**  
593 Tenth Ave.  
New York 10036  
LO-4-1880  
Irving Greene, general manager  
Irving Kempner, general sales manager  
Louis Wolberg, sales  
Bally, Irving Kaye, Nutting Assoc., Rowe, U.S. Auto-  
matic

**ALBERT SIMON, INC.**  
587 Tenth Ave.  
New York 10036  
LO-4-0006  
Albert Simon, president  
Albert D'Inzillo  
Auto-Photo, Rock-Ola, SEGA, U.S. Billiards, Williams.

**SHELDON SALES DIST. CORP.**  
550 Fillmore Ave.  
Tonawanda 14150  
694-5050  
John Cooper, president  
Anthony Illos, secretary  
Fred Iverson, manager  
All-Tech, Bally, Gottlieb, Irving Kaye, Rowe, United  
Billiards, Victor, Williams

**VASCO VENDING**  
311 Scholes St.  
Brooklyn  
Zachary Katz, general manager  
Cameron

## NORTH CAROLINA

**BRADY DIST. CO.**  
1900 W. Morehead St.  
Charlotte 28208  
375-1717  
C. B. Brady, president  
Jon Brady, vice president  
R. Blair Norris, asst. sec.-treasurer  
J. V. Bradley, parts manager  
George Ferrell, service manager  
Bally, Brunswick, Chicoin, Fischer, Midway, Wurlitzer.

**LESTOURGEON DIST. CO.**  
3100 S. Tryon St. P. O. Box 641  
Charlotte 28201  
523-5834  
Larry Lesturgeon, president  
Rock-Ola, U.S. Billiards.

**SOUTH ATLANTIC DIST. CO.**  
2407 Paula St. P.O. Box 26717  
Raleigh 27611  
Glenn Daughtry, manager  
Seeburg, Williams-United.

**THE VENDO CO.**  
3642 Tryclan  
Charlotte 28210  
Robert McClure, general manager  
Cameron

## NORTH DAKOTA

**M & S VENDING**  
306 6th North East  
Minot  
Cameron

## OHIO

**CLEVELAND COIN INTERNATIONAL**  
2029 Prospect Ave.  
Cleveland 44115  
861-6715  
Ronald Gold, president  
David Liebling, vice president  
William Rosenfield, sales director  
Henry Gisser, sec.-treasurer  
Larry Gold, manager  
American Hand Dryer, Automatic, Fischer, Gottlieb,  
Harmon, London Phonographic, Midway, Northwest-  
ern, Nutting Ind., SEGA, Universal, Valley, Williams,  
Wurlitzer.

**\*CLEVELAND COIN INTERNATIONAL**  
1827 Adams  
Toledo  
Stanley Knoll, manager

**J & J DIST. INC.**  
1401 Reading Rd. 45202  
Cincinnati  
721-6265  
W. Watson, president  
All-Tech, Brunswick, MDM, Rowe.

**J. M. NOVELTY CO.**  
5555 Mahoning Ave.  
Youngstown 44515  
J. M. Abraham, president  
Brunswick.

**LAKE CITY AMUSEMENT CO.**  
4531 Payne Ave.  
Cleveland 44103  
Joe Abraham, president  
Jobber

**MARTIN & SNYDER OF OHIO, INC.**  
4005 Carnegie Ave.  
Cleveland 44103  
391-5688  
Albert Gange, president  
F. J. Martin, vice president  
Seeburg.

**MONROE COIN MACHINE EXCH., INC.**  
2423 Payne Ave.  
Cleveland 44114  
781-4600  
Norman Goldstein, president

**MONROE COIN MACHINE EXCH., INC.**  
844 Hall Ave.  
Dayton 45404  
222-4005

**ROYAL DIST. CORP.**  
1210 Glendale-Milford Rd.  
Cincinnati 45215  
771-4250  
Joe Westerhaus Jr., president  
Automatic, Bally, Brunswick, Chicoin, Fischer, Gott-  
lieb, Midway, Valley, Williams, Wurlitzer.

# DISTRIBUTING ROWE-AMI

For The **FINEST** New & Used  
**MUSIC** and **VENDING** Equipment  
anywhere in the **WORLD**

The Trimount by Rowe.



Two offices for **FASTER** Service

Cleveland, Ohio, 2126 E. 21st Ave. (216) 241-2651

Columbus, Ohio, 1140 Chesapeake 488-1887

SHAFFER DISTRIBUTING CO

SHAFFER DISTRIBUTING CO

## DAVIS REBUILT & RECONDITIONED PHONOGRAPHS

### Seeburg Phonographs

222.....	\$250.
AY160.....	295.
DS160.....	395.
LPC480.....	495.
Electra.....	595.
Fleetwood.....	695.
SS160.....	795.

### Wurlitzer

2800.....	\$395.
3000.....	525.

### AMI

H120.....	\$150.
JEL200.....	225.
M200 Tropicana.....	375.
N200 Diplomat.....	495.

### Rock-Ola

426 160 Sel Grand Prix II.....	\$450.
424 100 Sel Princess Royal.....	395.
425 160 Sel Grand Prix.....	375.

### Seeburg Reconditioned Speakers

Hi-Fi HFCV3-8-Corner.....	\$25.00
Hi-Fi HFCV2-8-Wall.....	\$25.00
Extended Base EBPC-1.....	\$37.50

(Special Discount for Quantity Orders)

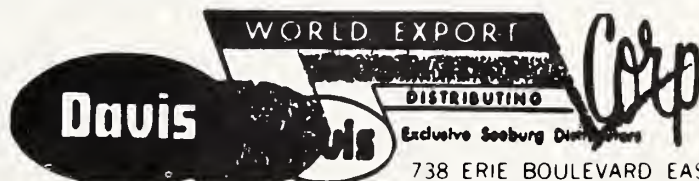

738 ERIE BOULEVARD EAST  
SYRACUSE NEW YORK 13210  
PHONE 475 1631  
AREA CODE 315

# U.S. Jobbers & Distributors Listed By States

**\*ROYAL DIST. CORP.**  
1112 N. High St.  
Columbus 43201  
294-5227  
Bob Burris, manager

**SEEVEND, INC.**  
457 Neilston St.  
Columbus 43215  
221-7821  
Alvin Giltitz, president  
Charles Gates  
Wil Randolph  
Seeburg, Williams.

**SHAFFER DIST. CO.**  
1140 Chesapeake Ave.  
Columbus 43212  
488-1888  
Ed Shaffer, president  
Bernie Flynn, vice president  
Steve Shaffer, vice president  
All-Tech, Irving Kaye, Litton, Midway, Moyer-Deibel,  
Rowe, Valley, Victor.

**\*SHAFFER DIST. CO.**  
2126 E. 21st St.  
Cleveland 44115  
241-2651

**STARK NOVELTY CO.**  
239 30th St. N.W.  
Canton 44709  
492-5382  
Paul Angeli, owner  
Jobber

**TOLEDO COIN MACHINE EXCH.**  
814 Summit St.  
Toledo 43604  
Rose Bennett, owner  
Bally, Valley.

## OKLAHOMA

**AUTOMATIC MUSIC DIST.**  
900 N. Western Ave.  
Oklahoma City 73106  
235-3456  
Harlan Drake, president  
John Porter, general manager  
Rowe.

**CULP DIST. CO.**  
614 W. Sheridan Ave.  
Oklahoma City 73102  
232-9511  
C. A. Culp, president  
Leroy Kitch, manager  
Wurlitzer.

**LAWTON BILLIARD SUPPLY**  
707 S. 11th St.  
Lawton 73501  
Brunswick.

**SUTHERLAND DIST. CO., INC.**  
Northwest Fourth and Lee Sts.  
Oklahoma City 73102  
Seeburg.

**TULSA BILLIARD SUPPLY**  
2112 S. Harvard  
Tulsa 74114  
John Nowlin, general manager  
Brunswick, United Billiards.

## OREGON

**BILLIARD SUPPLY HOUSE**  
5231 S. E. McLoughlin  
Portland 97202  
Joe Sheehan  
Pat Sheehan  
Brunswick.

**DUNIS DIST. CO.**  
1140 S. E. 7th Ave.  
Portland 97214  
Lou Dunis, president  
Allied, Seeburg, SEGA.

**NORTHWEST SALES CO. OF OREGON**  
5540 S. E. 26th Ave.  
Portland 97202  
234-7225  
Marshall McKee, general manager  
Lon McKee, sales manager  
John Scholl, service manager  
Jack Turner, parts manager  
Music Vend Dist.  
Portland  
Gottlieb.

**WESTERN DISTRIBUTORS**  
1226 S. W. 16th Ave.  
Portland 97205  
228-7565  
Budge Wright, owner  
Valley.

## PENNSYLVANIA

**ACTIVE AMUSEMENT MACHINES CO.**  
666 N. Broad St.  
Philadelphia 19130  
769-4495  
Joe Ash, president  
Frank Ash, vice president  
Martin Brownstein, sales manager  
Chicoin, Cointronics, Fischer, Gottlieb, Nutting, Rock-Ola.

**\*ACTIVE AMUSEMENT MACHINES CO.**  
1101 Pittston Ave.  
Scranton 18505  
Joseph Kovach, manager

**ATLAS MUSIC CO.**  
2231 Fifth Ave.  
Pittsburgh 15219  
471-1704  
Phil Greenberg, president  
Edward Shore, general manager  
Bally, Chicoin, Irving Kaye, Midway, Nutting Ind., Seeburg, Williams.

**BANNER SPECIALTY CO.**  
1213-31 N. 5th St.  
Philadelphia 19122  
236-5000  
James Ginsberg, vice president  
Marc Rodstein, treasurer  
Automatic, SEGA, U.S. Automatic, United, Universal,  
Valley, Williams, Wurlitzer.

**BANNER SPECIALTY CO.**  
1508 Fifth Ave.  
Pittsburgh 15219  
471-1373  
Herbert Rosenthal  
Gottlieb, Rowe, United, Valley, Williams.

**B. D. LAZAR CO.**  
1635 Fifth Ave.  
Pittsburgh 15219  
J. D. Lazar, president  
Edward Goldvarg, sec.-treasurer  
Bally, Chicoin, Gottlieb, Nutting Assoc., Rock-Ola.

**DAVID ROSEN INC.**  
855 N. Broad St.  
Philadelphia 19123  
CE-2-2900  
David Rosen, president  
Joseph Wasserman, vice president  
Harry Rosen, vice president  
Dave Weiss, sales manager  
Elliott Rosen  
Auto-Photo, All-Tech, Bally, Litton, Midway, Nutting  
Ind., Rowe, U.S. Automatic, U.S. Billiards, Victor.

**D. & L COIN MACHINE CO.**  
414 Kelker St.  
Harrisburg 17105  
234-4731  
David Berson  
Leon Takson  
Arnold Takson  
Irving Kaye

**D. & P MUSIC**  
27 Philadelphia St.  
York 17403  
848-1846  
David Patz, manager, jobber

**EASTERN MUSIC SYSTEMS CORP.**  
334 N. Broad St.  
Philadelphia 19102  
LO-4-4415  
Marvin Stein, president  
Melvin Sonier, executive vice president  
Frank Nolan, vice president  
Robert Marvel Jr., treasurer  
Philip Sternberg, used equipment sales manager  
Seeburg, Williams.

**FLEXER BROTHERS AMUSEMENT**  
2016 W. 4th St.  
Williamsport 17701  
Walter Flexer, president  
Brunswick.

**MICKEY ANDERSON AMUSEMENT CO.**  
314 E. 11th St.  
Erie 16503  
452-3207  
Michael Anderson, owner  
Michael Anderson Jr., manager  
Automatic, Bally, Irving Kaye, Tape-Athon, United  
Billiard, Valley, Wurlitzer.

**PENNSYLVANIA DIST.**  
Route 220 P.O. Box 61  
Tipton  
Cameron.

**ROTH NOVELTY CO.**  
54 North Pennsylvania Ave.  
Wilkes-Barre 18701  
824-9994  
Marvin Roth, owner  
Walter Haczewski, general manager  
Leonard Lukas, sales manager  
Roger Samuels, service manager  
American Shuffleboard, Automatic, Bally, Irving Kaye,  
Midway, Wurlitzer.

**SAUNIER-WILHELM CO.**  
3216 Fifth Ave.  
Pittsburgh 15213  
James Wilhelm, president  
Brunswick.

## SOUTH CAROLINA

**PEACH STATE TRADING CO.**  
1104 Shop Road P.O. Box 1482  
Columbia 29202  
254-6928  
Bill Whitcomb, manager  
American Shuffleboard, Bally, Brunswick, Chicoin,  
Irving Kaye, Fischer, Gottlieb, Litton, Rowe, Victor.

**SOUTH ATLANTIC DIST. CO.**  
716 Huger St.  
Columbia 29201  
253-7565  
Jim McNeely, manager  
Seeburg, Williams.

## TENNESSEE

**GAME SALES CO., INC.**  
262 S. Camilla St.  
Memphis  
275-2356  
Robert Goad, president  
All-Tech, American Shuffleboard, Bally, Fischer, Midway, Nutting Ind., Williams.

**HERMITAGE MUSIC CO.**  
469 Chestnut St.  
Nashville 37203  
244-1790  
George Meczyzme  
Wilson Bracey  
American Shuffleboard, All-Tech, Beaver Vendors, Nutting Assoc., Rowe, U.S. Billiards.

**ROCK CITY DIST. CO.**  
615 Murfreesboro Rd.  
Nashville 37210  
242-4353  
Ken Brake Sr., president  
Tom Watts, manager  
Wurlitzer.

**SAMMONS-PENNINGTON CO., INC.**  
440 Monroe Ave.  
Memphis 38103  
526-0611  
George Sammons, president  
"Cotton" Pennington, sec.-treasurer  
All-Tech, Brunswick, Lekro-Vend, Litton, Seeburg, U.S.  
Automatic, United, Universal, Williams.

**\*SAMMONS-PENNINGTON CO., INC.**  
214 6th Ave. S.  
Nashville 37203  
255-1129  
"Stub" Thomas, vice president

**SANDERS DIST. CO.**  
612 8th Ave. S.  
Nashville 37203  
255-4119  
G. M. Happell, general manager  
Bally, Gottlieb, Irving Kaye, Rock-Ola.

**S & M DIST. CO., INC.**  
462 N. Second St.  
Memphis 38105  
Rock-Ola.

# You've Never Seen Games So Clean

Factory Distributors for:



Serving the Industry  
from our Cincinnati  
and Columbus Offices

### Royal Distributing Corp.

1112 North High Street  
Columbus, Ohio  
PHONE: 614-294-5227  
Ray Hetterscheid Bob Burris  
Royal One-Stop  
1021 E. B'way., Louisville, Ky.  
John Beckman (502) 584-3671

### Royal Distributing Corp.

1210 Glendale-Milford Road  
Cincinnati, Ohio 45215  
PHONE: 513-771-4250  
Joe Westerhaus Jr.  
Jim Wall Jerry Grotjan  
Jack Schleicher Jim Ernst



# U.S. Jobbers & Distributors Listed By States

**SOUTHERN AMUSEMENT DIST. CO.**  
628 Madison Ave.  
Memphis 38103  
525-3609  
O. J. Mullinin, vice president  
C. V. McDowell, sales manager  
Wolf Lebovitz, credit manager  
All-Tech, Chicoin, Fischer, Rower, Victor.

## TEXAS

**ALL-COIN EQUIPMENT CO.**  
121 Navarro St.  
San Antonio 78205  
United Billiards.

**B & B SUPPLY**  
Dallas 75221  
Brunswick.

**CENTRAL SALES CO.**  
91 Dennis  
Houston 77006  
523-7464  
Hans Von Reydt, manager  
Rowe.

**COMMERCIAL MUSIC CO., INC.**  
1550 Edison St.  
Dallas 75207  
741-6381  
Ray Williams, president  
Jack Eskew, manager  
Wurlitzer.

**EAST TEXAS BILLIARD SUPPLY**  
Longview 756-01  
Brunswick.

**GULF COAST DIST. CO.**  
6205 Gulf Freeway  
Houston 77023  
923-5906  
L. C. Butler, president  
Ben Wells, sales representative  
All-Tech, Automatic, Midway, U.S. Billiards, Wurlitzer.

**\*GULF COAST DIST. CO.**  
730 S. Santa Rosa  
San Antonio 78207  
227-3400  
Gus Wueste, manager

**H. A. FRANZ & CO.**  
606 Dennis  
Houston 77006  
H. A. Franz, president  
Seeburg.

**L. E. CORP.**  
2700 Milam at Dennis  
Houston 77002  
523-7494  
Don Siegel, president  
Automatic, Bally, Brunswick, Coffe-Mat, Fischer, Irving  
Kaye, Midway, Rock-Ola, U.S. Automatic.

**O'CONNOR DIST. CO., INC.**  
9030 Directors Row  
Dallas 75247  
Seeburg.

**PLAINS BILLIARD SUPPLY**  
605 Ave. 1  
Lubbock 79401  
Charles Lovell, general manager  
Brunswick.

**SANTONE SALES CO.**  
1400 S. Flores St.  
San Antonio 78205  
227-5181  
Luis Jamail, manager  
Rowe.

**STATE MUSIC DIST., INC.**  
3100 Main St.  
Dallas 75226  
Rock-Ola.

**SOUTHERN VENDING SALES CO., INC.**  
1327 Chemical St.  
Dallas 75207  
638-4280  
Jim Browning, manager  
Litton, Rowe.

**SUTHERLAND DIST. CO.**  
3902 Pershing St.  
El Paso 79903  
Seeburg.

**SUTHERLAND DIST. CO.**  
226 S. Flores St.  
San Antonio 78204

**THE VENDO CO.**  
2649 Perth St.  
Dallas 75220  
Richard Roberts, general manager  
Cameron.

**WALLACE DIST. CO.**  
205 N. E. First Ave. P. O. Box 75  
Mineral Wells 76067  
325-3600  
Dock Ringo, president  
W. O. Wilborn, vice president  
American Shuffleboard, Chicoin, Rowe, Valley.

**WICHITA RECREATION**  
Wichita Falls 76307  
Brunswick.

## UTAH

**BEST DISTRIBUTING, INC.**  
3753 S. State St.  
Salt Lake City 84115  
262-5493  
Ben Conford, general manager  
All-Tech, Automatic, Brunswick, Chicoin, Rock-Ola.

**DIAMOND DIST. CO.**  
375 S. Second St. W.  
Salt Lake City 84110  
Garth Brown  
Rowe.

**STRUVE DIST. CO., INC.**  
276 W. First St. S.  
Salt Lake City 84101  
Press Struve, president  
Nutting Assoc., Seeburg, U.S. Billiards, Williams-  
United.

## VIRGINIA

**\*BUSH INTERNATIONAL**  
6003 W. Broad St.  
Richmond 23230  
282-4221

**DANVILLE AMUSEMENT CO.**  
620 Westover Dr.  
Danville  
Jobber

**O'CONNOR DIST. CO.**  
2320 W. Main St.  
Richmond 23220  
359-3264  
Ken O'Connor, president  
Brunswick.

**SIRBAUGH'S BILLIARD SUPPLY**  
136 S. Loudon St.  
Winchester 22601  
Jim Sirbaugh, president  
Brunswick.

**SOUTHEASTERN VENDING DIST.**  
601 Woodis Ave.  
Norfolk 23510  
Bernie Inge, president  
NSM, SEGA.

**THE VENDING MACHINE EXCH.**  
63 Commonwealth Ave.  
Bristol 24201  
669-7147  
E. M. Hudson, owner  
All-Tech, Rock-Ola, United, Williams.

## WASHINGTON

**AMERICAN SHUFFLEBOARD SALES CORP.**  
425 Aurora Ave. N.  
Seattle 98109  
MU-2-4495  
Leslie Lystad, president  
Leigh Brownell, vice president  
Viola Wyse, sec.-treasurer  
All-Tech, American Shuffleboard, Rock-Ola.

**MUSIC VEND DIST. CO.**  
100 Elliott West  
Seattle 98119  
Ray Galente  
SEGA.

**NORTHERN BILLIARDS**  
10744 1/2 5th N.E.  
Seattle 98125  
Brunswick.

**NORTHWEST SALES CO.**  
3150 Elliott Ave.  
Seattle 98121  
284-8030  
Ron Pepple, president  
Marshall McKee, sec.-treasurer  
"Buzz" Heyer, sales manager  
Walt Merritt, service manager  
John Kage, parts manager  
Automatic, Bally, Chicoin, Cornelius-Avenco, Fischer,  
Irving Kaye, Midway, Nutting Assoc., Universal, Val-  
ley, Wurlitzer.

**RAINBOW ENTERPRISES, INC.**  
11726 Aurora N.  
Seattle 98133  
Jobber

**ROVENDCO INTERNATIONAL**  
309 9th Ave. N.  
Seattle 98109  
624-7594  
Alton Paap, manager  
A. A. Augustine, salesman  
Rowe.

## WEST VIRGINIA

**CRUZE DIST. CO., INC.**  
1101 W. Washington St.  
Charleston 25302  
344-4566  
W. T. Cruze, president  
Wurlitzer.

**WALLACE & WALLACE MUSIC, INC.**  
401 Jones Ave.  
Oak Hill 25901  
Rock-Ola.

## WISCONSIN

**BADGER NOVELTY CO., INC.**  
3057 N. 35th St.  
Milwaukee 53210  
442-1440  
Orville Carnitz, president  
Jobber

**\*EMPIRE DIST., INC.**  
2267 Main St.  
Green Bay 54301  
Bob Rondeau, division manager  
Automatic, Avendco, Bally, Chicoin, Gottlieb, Midway,  
Rock-Ola, Westinghouse.

**HASTINGS DIST., INC.**  
6100 W. Bluemond Rd.  
Milwaukee 53213  
Jack Hastings, vice president  
Walter Bohrer Jr., general manager  
Rock-Ola, Smoke Shop, Valley.

**PIONEER SALES AND SERVICE INC.**  
3110 W. Fond du Lac Ave.  
Milwaukee 53210  
445-9340  
Joel Kleiman, president  
Sam Cooper, vice president  
Brunswick, Chicoin, Fischer, Litton, MDM, Rowe, Valley,  
Victor.

## IMPORTANT NOTICE

For the very best values in  
flippers, bingos, guns, base-  
ball games and arcade  
equipment, always check  
our weekly ad in the classi-  
fied advertising section of the  
Cash Box.

## NEW ORLEANS NOVELTY CO.

(Famous for Used Games)

1055 Dryades Street  
New Orleans, Louisiana  
529-7321 Cable: NONOVCO

**S. L. LONDON MUSIC CO., INC.**  
3130 W. Lisbon Ave.  
Milwaukee 53208  
344-3220  
Sam London, president  
Perry London, vice president  
Nathan Victor, asst. secretary  
Martha Schalk, asst. secretary  
Seeburg, Williams.

**UNITED INC.**  
3415 N. 127th St.  
Brookfield 53005  
781-2080  
Paul Jacobs, president  
Russell Townsend, vice president  
Candimat, United Billiards, Valley, Vendo, Wurlitzer.

# 34 years

of honest, dependable  
service to the coin  
machine trade

... and thru the years with

# Seeburg

the industry's finest name!

DISTRIBUTORS FOR  
**WILLIAMS • MIDWAY**  
**BALLY • CHICAGO COIN**

## ATLAS MUSIC CO.

2231 Fifth Ave., Pittsburgh, Pa.  
Tel: (412) 471-1704

**BUY! METAL  
TYPERS**  
VENDING ALUMINUM  
IDENTIFICATION DISC  
**WHY!**

1. LIFE-TIME INCOME
2. TROUBLE-FREE OPERATION
3. ONLY 18"x18"

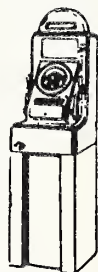

**STANDARD HARVARD**  
METAL TYPERS, INC.

312 — 384-3120, Dept. 21  
1318 N. WESTERN AVE.  
CHICAGO, ILL. 60622

## Flipper Game Specialists

Representing  
D. Gottlieb & Co.

## IRVING MORRIS, INC.

CALL BI 3-4300 FOR PROMPT SERVICE

145 FRELINGHUYSEN AVE., NEWARK, NEW JERSEY 07114

# NATIONAL & STATE COIN MACHINE ASSOCIATIONS

**MUSIC OPERATORS OF AMERICA**  
228 N. LaSalle St.  
Chicago, Ill. 60601  
Exec. V-P Fred Granger

**NATIONAL VENDORS ASSOCIATION**  
Suite 1725, 69 W. Washington  
Chicago, Ill. 60602

**NATIONAL AUTOMATIC MERCHANDISING ASSOCIATION**  
7 S. Dearborn St.  
Chicago, Ill.  
Pres. Dick Schriber

**ARIZONA**  
  
Arizona Coin Machine Ops. Association  
1525 E. Washington  
Phoenix, Arizona 85034

## CALIFORNIA

California Music Merchants Association  
128 E. 14th Street  
Oakland, Calif. 94606  
Pres. C. G. Silla

## CONNECTICUT

Music Operators of Connecticut  
242 Trumbull St.  
Hartford, Conn. 06103

## FLORIDA

A.M.O.A. of Florida  
8163 N.E. 2nd Ave.  
Miami, Fla. 33138  
Pres. James Mullins

Florida Amusement & Music Ass'n.  
P.O. Drawer 1519  
Winter Haven, 33880  
Exec. Dir. Robert Rheinehart

## ILLINOIS

Associated Buyers Club  
4206 N. Western Ave.  
Chicago, Ill. 60618

ICMOA  
Ridgely Bldg., Suite 715  
Springfield, Ill. 62701  
Exec. Dir. Fred Gain

Music Operators Of No. Illinois  
8020 Lincoln Ave.  
Skokie, Ill. 60076

Recorded Music Service Ass'n.  
188 Randolph St.  
Chicago, Ill. 60601

## INDIANA

Music Operators Society of St. Jos. Valley  
130 N. Ironwood Dr.  
Mishawaka, Ind. 46544

## KANSAS

Kansas Amusement & Music Ass'n.  
1617 Harry, W.  
Wichita, Kan. 67213

## MASSACHUSETTS

Mass. Coin Machine Association  
116 Race St.  
Holyoke, Mass. 01040

Western Mass. Music Guild  
116 Race St.  
Holyoke, Mass. 01040

## MINNESOTA

Music Operators Of Minnesota  
1119 Fifth Place, S. E.  
Austin, Minn. 55912

## MISSOURI

Missouri Coin Machine Council  
302 W. 10th  
Trenton, Mo. 64683

## MONTANA

Montana Coin Machine Op's. Ass'n.  
815 S. Central Ave.  
Malta, Mont. 59538

## NEBRASKA

Coin Operated Industries Of Neb.  
1208 Farnam St.  
Omaha, Neb. 68102

## NEW JERSEY

South Jersey Coin Machine Ass'n.  
805 Hopkins Road  
Haddonfield, N. J. 08033

N. J. Council of Coin Machine Op's.  
1175 Broad St.  
Newark, N. J. 07114

Vending Guild of New Jersey  
1175 Broad St.  
Newark, N. J. 07114  
Pres. Allen Waldor

Garden State Amusement Op's. Ass'n.  
1201 Lakewood Rd.  
Toms River, N. J. 08753

## NEW MEXICO

New Mexico Music Guild  
217 Claremont Ave., N. W.  
Albuquerque, N. M. 87107

## NEW YORK

Music Op's of New York  
250 W. 57th St.  
New York, N. Y. 10019

New York State Coin Machine Ass'n.  
Box 204  
Hurleyville, N. Y. 12747

New York State Operators Guild  
P.O. Box 371  
Beacon, N.Y. 12508

Westchester Operators Guild  
125 N. Main St.  
Port Chester, N. Y. 10573

## NORTH CAROLINA

N. Carolina Op's Ass'n.  
111 S. Front St. Box 3154  
Wilmington, N. C. 28403

## OHIO

Northwestern Ohio Music Op's. Ass'n.  
511 S. Canal St.  
Delphos, Ohio 45833

## OREGON

Oregon Amusement & Music Op's.  
5007 N. E. Prescott  
Portland, Ore. 97218

## PENNSYLVANIA

Amusement Machine Ass'n. of Phila.  
850 N. Broad St.  
Phila, Pa. 19130

Eastern Penn. Amusement Machine Ass'n.  
341 Fairview  
Stowe, Pa. 19464

## SOUTH CAROLINA

S. C. Coin Op's. Ass'n.  
3225 Quitman Dr.  
Columbia, S. C. 29204

## SOUTH DAKOTA

Music & Vending Ass'n. of S. D.  
901 E. 7th Ave.  
Mitchell, S. D. 57301

## UTAH

Utah Music Guild  
161 First Ave.  
Salt Lake City, Utah 84103

## VIRGINIA

Music Operators of Virginia  
2906 Chamberlayne Ave.  
Richmond, Va. 23222

## WEST VIRGINIA

West Virginia Music & Vending Ass'n.  
1114 Nutter St.  
Clarksburg, W. Va. 26301

## WISCONSIN

Milwaukee Music Op's. Ass'n.  
6100 W. Bluemound Rd.  
Milwaukee, Wis. 53213

Wisconsin Music Merchants Ass'n.  
115 Smythe Ct.  
Beaver Dam, Wis. 53916

## Happy Anniversary

*Sincerest and Best Wishes*

to

## CASH BOX

On Its 28th Anniversary

**MUSIC OPERATORS of NEW YORK, Inc.**

NEW YORK, N. Y.

AL DENVER, Pres.

**SINCEREST BEST WISHES TO**

## CASH BOX

on its 28th Anniversary

**ILLINOIS COIN MACHINE OPERATORS ASSN.**

Suite 715, Ridgely Building Springfield, Ill. 62701

# Attention!

DISTRIBUTORS

MANUFACTURERS — OPERATORS

*America's Lowest Life  
Insurance Rates*

*Leading Insurers of Credit Life and  
All Risk Insurance on Equipment on  
Location*

ANNUAL PREMIUMS  
Level Commercial Term

AGE	5 YR	10 YR	15 YR
30	\$308.00	\$ 323.50	\$ 335.50
35	359.00	396.50	426.50
40	469.00	536.50	596.50
45	655.00	741.50	871.50
50	937.00	1,089.50	1,346.50

WAIVER OF PREMIUM BENEFITS AVAILABLE  
MINIMUM POLICY \$100,000.00 — CONVERTIBLE

# SPINDEL

**INSURANCE AGENCY INC.**

8551 Stony Island Ave.  
Chicago, Ill. 60617  
Area 312-374-3700

4710 N. 16th Street  
Phoenix, Ariz. 85016  
Area 602-279-9509



**NSM**  
*restige*  
**160**

Phonograph

"Trifles make perfection...  
but perfection is no trifle"

- \* A unique musical money maker
- \* Fully electronic
- \* 160 selections
- \* Credit unit adjustable for various pricings
- \* Dual speed—45 and 33 $\frac{1}{3}$  rpm
- \* Three wire remote control

**The World Standard  
for the Industry**

*Exclusive representatives through quality distributors in the U.S.:*

**A. C. A. Sales and Service**

OAKLAND: 2230 E. 14th St., (415) 533-3421

LOS ANGELES: 2891 W. Pico Blvd., (213) 737-0104

**WEST COAST  
LARGEST  
EXPORTERS  
OF QUALITY  
GAMES**

**MUSIC • ARCADE**

Write for Special Price List

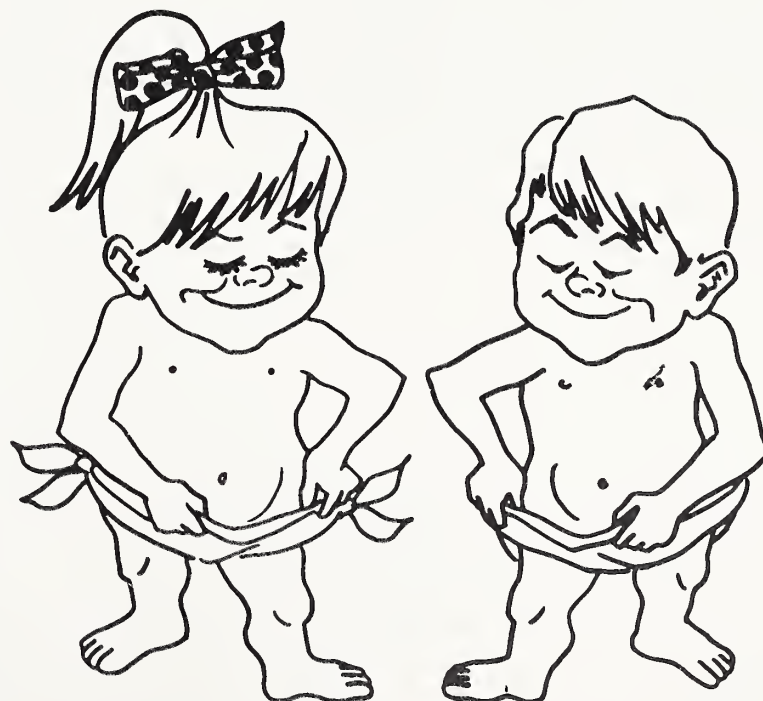

There's a  
difference

That's what  
counts



**ACA SALES & SERVICE**

(Formerly Simon Distributing Co.)

2891 W. Pico Blvd., Los Angeles, Calif. 90006

(213) 737-0104

Cable address ACASALES  
Telex #0674430



Thanks  
Elvis



**ANNUAL  
WORLD WIDE  
DIRECTORY**

*28th Anniversary Edition*

1970-1971

**INTERNATIONAL SECTION**

# **In every major market, CBS is its own boss. And all the difference in the**

Because CBS has its own subsidiaries, you don't get the best parts of the music world in the worst kind of mix-up. As sometimes happens with scattered licensees.

Instead you get a network of subsidiaries that can solve problems all over the world for you. While you stay at home. They work harder for you because your business is their job. And their job is our business.

So when they put you into the local music industry, you go where you want to go. Whether they record for you. Or master. Press. Merchandise. Promote. Advertise. Distribute. Or publish. You're in control.

Because we're very much in control.

And for your business, that'll make the world a better place to be in.

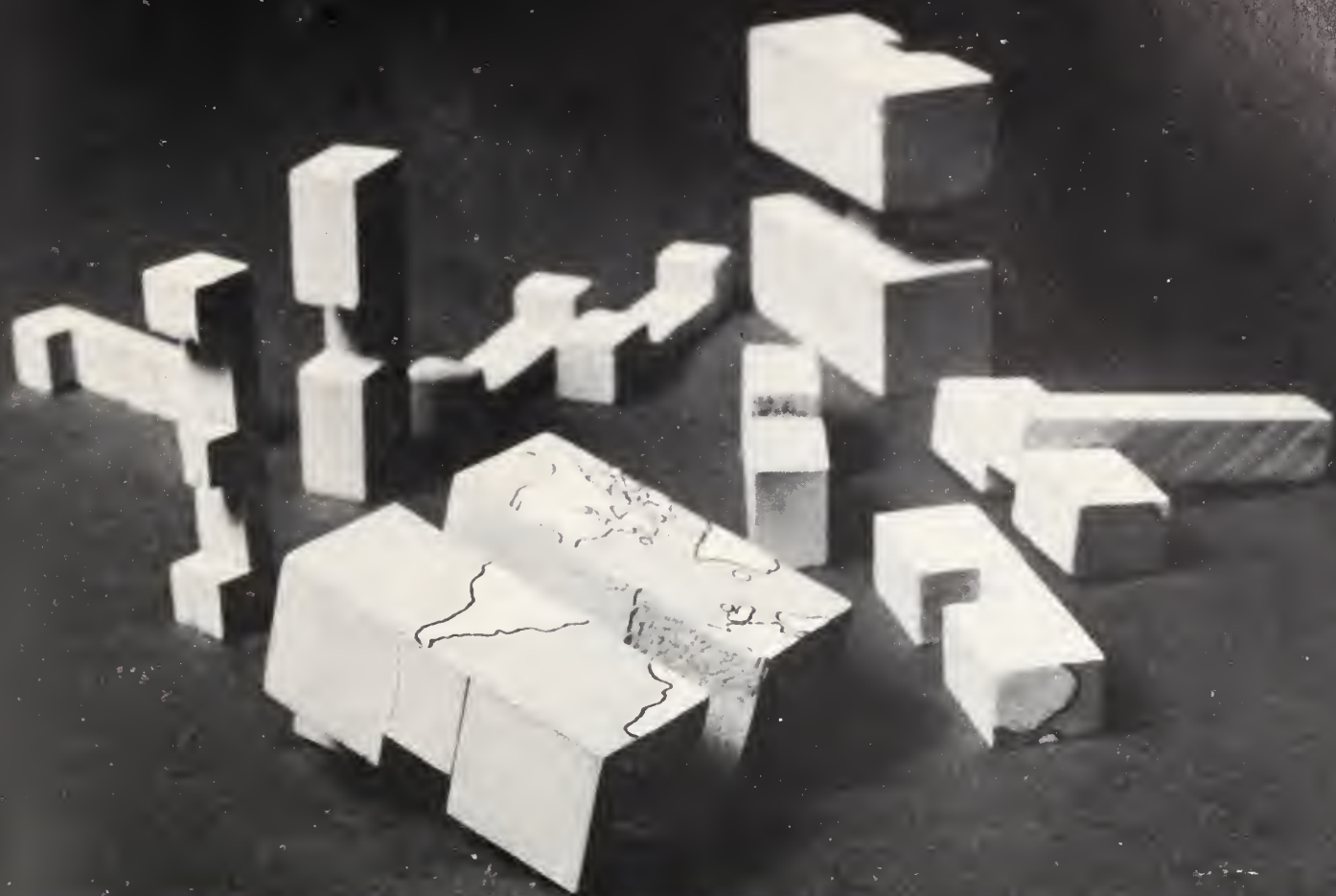

**that could make  
world.**



CBS Records  Entertaining the Entire World  
CBS International, 51 West 52 Street, New York, N.Y. 10019 Tel. 765-4321

# ENGLAND: The Past 12 Months

The year ended April 30th 1970 has seen several major changes in the British music industry. Like all changes, they have taken their toll of victims, but reflect the altering conditions and revised philosophies as a new decade dawned that will transpire to be the most important and significant watershed in the history of international popular music. The calendar year of 1969 proved to be the best yet in terms of British record manufacture and sales. The statistics hit their highest peak yet, with the LP leading the way — solid facts of success that might surprise those aware of the regular gripes and despondency expressed in several quarters at regular intervals about the viability and buoyancy of the music industry's future. Even the 45 r.p.m. disk showed distinct signs of rallying towards the end of the year, confounding those who had predicted its imminent total demise. The year under review began with further evidence of the polarisation of the retail market. EMI Records set forth its new sales theory of the Music Center concept, retail outlets comprising an elite of about 500 of the top dealers accounting for a high proportion of total sales throughout the country. These dealers stock an agreed minimum of EMI catalog material at all times, and are classified in two categories according to the volume of their trade. EMI prepares the catalog packs and offers regular dividends in the shape of special promotions and favorable trading terms, and gets action across the whole range of its product in return. Song-writer-musical director Les Reed laid plans for his infant Chapter One label distributed by Decca with the signing of the Bournemouth Symphony Orchestra, a pact that has not yet seen its first release. Reed's busy schedule was increased with commitment to a couple of TV spectaculars featuring him and his music and a crop of disk releases on his songs. Charlie Koppelman, Don Rubin and John Gross announced plans for the later launching

of their own music company here and Shapiro-Bernstein Music captured the score and cast album recording assignment for the Cyril Ornadel-David Croft musical "Ann Veronica." Britain shared in the rather ludicrous result of the 1969 Eurovision Song Contest with no less than four songs tying for first place. Lulu sang the U.K. entry "Boom Bang-a-Bang." Pye Records won U.K. representation rights to the new Metromedia label subsidiary of the New York Metromedia Corporation and also acquired the remaining 49% equity interest of the Alex Strickland chain of retail shops. Mervyn Conn readied the first International Festival of Country & Western Music at the Wembley Empire Pool on April 5th with a star contingent from the States and CBS did a manufacture and distribution deal for the Reflection label offshoot of Artists Musical Productions.

APRIL litigation ensued between Nemperor Holdings and the Triumph Investment Trust on one side and EMI on the other about whom should receive disk royalties earned by the Beatles. EMI was upheld in its declaration that it would pay no royalties to anyone until the whole dispute was resolved and the judge dismissed the case. RCA opened a Red Seal classical operation headquarters for Europe at its London base in Curzon Street, and Rosemary Schnutz was named as its administrator. Charles Curran succeeded Sir Hugh Greene as director general of the BBC and his appointment marked the beginning of a bitter and acrimonious wrangle inside the BBC and outside about its future plans and policy. The Beatles started their campaign to prevent Northern Songs, their publishing outlet, passing into the control of Associated Television. The Paramount label celebrated its first British release of the "Oh What a Lovely War" soundtrack album with an old time lunch at Flanagan's and the Atlantic-Atco month in Britain got underway with

an American tour as the winning prize. The April budget slammed the amusement machine trade with increased duty and a new excise duty, curtailed evasive measures by big-earning stars to minimise their tax assessments, and hit the whole music industry with an increase in the Selective Employment Tax. Morgan Records and Morgan Studios amicably parted company and Tony Bennett arrived to an SRO tour with Count Basie.

MAY saw The Beatles continuing their battle for Northern Songs with a counter bid of over £2 million against ATV and Essex Music European chief David Platz emerged as a major adviser to the Beatles on their publishing affairs.

RCA named Ian Grant as U.K. A&R chief and Tommy Loftus as Head of Promotion. Performing Right Society general manager R.F. Whale lambasted the Singapore Government on its denial of royalties on music broadcast over its radio station. The Fidelity group announced plans for a \$3 million recording and movie complex in north London to be called Advance. The House of Commons rejected a bill to enable the Greater London Council to operate a commercial radio system and Dick James' DJM label signed actor Edward Woodward, star of the TV counter-espionage series called "Carlan." ATV neared victory in the struggle for Northern Songs, despite

(Con't. on Page 9)

## GR. BR. INDEPENDENT RECORD PRODUCERS

**ACUFF-ROSE MUSIC LTD.**  
15, St. George Street  
Hanover Square  
London W.1  
Tel.: May 0392  
Ron Randall

**A.I.R. (LONDON) LTD.**  
108, Park Street  
London W.1  
Tel.: 01-493 4131  
George Martin, John Burgess,  
Ron Richards & Peter Sullivan

**APPLE CORPS LTD.**  
3, Savile Row,  
London W.1  
Tel.: 01-734 8232  
Directors: J.O. Lennon, G. Harrison

**AXLE ENTERPRISES LTD.**  
2, Holly Mount  
London N.W.3  
Tel.: 01-435 4341  
Alan Blaikley & Ken Howard

**BOSCOBEL PRODUCTIONS**  
12a, St. George Street  
Hanover Square  
London W.1  
Tel.: 01-493-1141

**CHAPPELL & CO.**  
50 New Bond Street  
London W.1  
Tel.: 01-629 7600

**CITY MUSIC**  
110, Beach Road  
Scratby  
Great Yarmouth  
Norfolk  
Tel.: Ormesby 658  
B.A. Palmer

**COLORTONE RECORD CO.**  
Royal House  
1 & 2 Royal Parade  
Dawes Road  
London S.W.6  
Tel.: 01-385 5660  
Ziggy Jackson

**CONCORD RECORDS LIMITED**  
10, Denmark Street,  
London W.C.2  
Tel.: 01-836 1653  
Roy Berry & Terry Kennedy

**MIKI DALLON ENTERPRISES LTD.**  
138, New Bond Street  
London W.1  
Tel.: 01-493 9681  
Miki Dallon

**DANDY PRODUCTIONS LTD.**  
Chandos House  
45/46, Chandos Place  
London W.C.2  
Tel.: 01-836 7255  
Mervyn Conn

**FAMILY CIRCLE PRODUCTIONS**  
23, Old Burlington Street  
London W.1  
Tel.: 01-734 9942  
Steve Rowland & Martin Machat

**FINITO**  
60, Castellain Road  
Maida Vale  
London W.9  
Tel.: 01-289 0534  
Adrian Rudge & Tony Palmer

**HENSLEY MUSIC PRODUCTIONS**  
Lindsay House  
171, Shaftesbury Avenue  
London, W.C.2

**HIT RECORD PRODUCTIONS LTD.**  
29/31, Oxford Street  
London W.1  
Tel.: 01-437 5063  
Gerry Bron

**TIM HOLLIER PRODUCTIONS**  
6, New Compton Street  
London W.C.2  
Tel.: 01-836 8171  
Tim Hollier & Roger Fennings

**MARQUIS ENTERPRISES LTD.**  
37, Soho Square  
London W.1  
Tel.: 01-437-9405  
Joe Roncoroni & Ken Jones

**MARTIN COULTER ENTERPRISES**  
122, St. George Square Mews  
London S.W.1  
Tel.: 01-826-3780  
Bill Martin & Phil Coulter

**NEMS ENTERPRISES LTD.**  
Nemperor House  
Hill Street  
London W.1  
Tel.: 01-629-6341  
Vic Lewis

**NEXUS PRODUCTIONS**  
37, Soho Square  
London W.1  
Tel.: 01-437-1893

**NORMAN NEWELL ORGANISATION**  
66, Montague Mansions  
Baker Street  
London W.1  
Tel.: 01-935-4133  
Norman Newell

**NOEL BROWN PRODUCTIONS**  
70/71, New Bond Street  
London W.1  
Tel.: 01-493-1911  
Noel Brown

**ORBIT MUSIC CO. LTD.**  
10, Albert Court  
124, Knightsbridge  
London S.W.1  
Tel.: 01-589-6293  
Shel Talmay

**RAK RECORDS LTD.**  
155/157, Oxford Street  
London W.1  
Tel.: 01-437-6671  
Mickie Most

**RECORD SUPERVISION LTD.**  
Lansdowne House  
Lansdowne Road  
London W.11  
Tel.: 01-727-0041  
Denis Preston

**RITZ RECORDS**  
8, Apollo Place  
Chelsea  
London S.W.10  
Tel.: 01-352-1182/3/4

**SCOTT-SOLOMON PRODUCTIONS LTD.**  
58/59, Gt. Marlborough Street  
London W.1  
Tel.: 01-437-5803  
Tommy Scott & Philip Solomon

**SEPTEMBER MANAGEMENT**  
30, St. George Street  
London W.1  
Tel.: 01-493-0559  
Sandy Robertson

**S.N.B. PRODUCTIONS**  
39, South Street  
London W.1  
Tel.: 01499-1553  
Mr. Daly

**THE ROBERT STIGWOOD ORGANISATION LIMITED**  
67, Brook Street  
London W.1  
Tel.: 01-May-9121  
Robert Stigwood

**VOX PRODUCTIONS (G.B.) LTD.**  
11, Elgodd House  
Wellington Road  
London N.W.8  
Tel.: 01-722-1208  
P. Fejer

**WITCHSEASON PRODUCTIONS**  
83, Charlotte Street  
London W.1  
Tel.: 01-636-9436  
Joe Boyd

### INTERNATIONAL REPRESENTATION

THROUGH

## THE BURLINGTON-PALACE MUSIC GROUP

### BRITISH ISLES

**BURLINGTON MUSIC CO. LTD.**  
9 Albert Embankment,  
London, S.E. 1.

and

**PALACE MUSIC CO. LTD.**  
9 Albert Embankment,  
London, S.E. 1.

### U.S.A.

**BURLINGTON MUSIC CORPORATION**  
539 West 25th Street,  
New York, N.Y. 10001

and

**FELSTED MUSIC CORPORATION**  
539 West 25th Street,  
New York, N.Y. 10001

### CANADA

**BURLINGTON MUSIC OF CANADA LTD.**  
190 Graveline Road,  
St. Laurent, P.Q.

and

**FELSTED MUSIC OF CANADA, LTD.**  
190 Graveline Road,  
St. Laurent, P.Q.

### AUSTRALASIA

**PALACE MUSIC (PTY) LIMITED**  
4th Floor  
318, Pitt Street,  
Sydney, N.S.W.

### SOUTH AFRICA

**BURLINGTON MUSIC (AFRICA)**  
a division of  
**MUSIC PUBLISHING CO. OF AFRICA (PTY) LIMITED**

**GALLO CENTRE**  
Cor. Kerk & Gold Streets,  
Johannesburg, S. Africa

### GERMANY & AUSTRIA

**BURLINGTON MUSIKVERLAG GmbH.**  
Hoehenweg 22,  
8211 Rimsting (Chiemsee)  
Bavaria, Germany

### FRANCE &

### FRENCH UNION

**EDITIONS MUSICALES PALACE Sarl.**  
89, Rue La Boetie, Paris 8

### SPAIN

**BURLINGTON MUSIC ESPANOLA**  
Desengano 4, Madrid 13.

### BENELUX

**N.V. PALACE MUSIC HOLLAND**  
Vondelstraat 90, Amsterdam 1.

### SCANDINAVIA

**PALACE MUSIC (SWEDEN) A.B.**  
Jungfrugatan 18, Stockholm 0.

### ITALY

**EDIZIONI MUSICALI PALACE Srl.**  
Piazzetta Pattani 1 3  
Milano

### ORIENT

**BURLINGTON-PALACE MUSIC ORIENT LTD.**  
The House, 3, Salisbury Road,  
Kowloon, Hong Kong.



K. A&R  
Head of  
Society  
e lam-  
ment on  
broad-  
fidelity  
\$3 mil.  
plex in  
vance  
cted a  
Com-  
to sys-  
signed  
of the  
called  
in the  
despite  
Page 9



WORLD  
OF  
MANY  
COUNTRIES  
GANGS

# MCA RECORDS WORLD OF THE MANY COUNTRIES

## ARGENTINA

RCA Victor Argentina, S.A.I.C.  
MR. A. PINO

## AUSTRALIA

Astor Electronics  
MR. NEVILLE SMITH

MCA Records Australia  
MR. ALAN A. FREEMAN

## AUSTRIA

AMADEO Österreichische Schallplatten  
Aktiengesellschaft  
MR. STEPHAN VON FRIEDBERG

## BELGIUM

Inelco Belgium, S. A.  
MR. PIERRE-JEAN GOEMAERE

## BRAZIL

Gravacoes Chantecler Ltda.  
MR. J. RIBEIRO

## CANADA

The Compo Company, Ltd.  
MR. ROBERT CHISLETT  
MR. LEE ARMSTRONG

## CENTRAL AMERICA

COSTA RICA/EL SALVADOR/GUATEMALA  
HONDURAS/NICARAGUA/PANAMA  
Caceres Discos, S. A.  
MR. ROBERTO CACERES R.

## COLOMBIA

Fabrica de Discos Fuentes, S. A.  
MR. PEDRO FUENTES E.

## DENMARK

Hede Niensens Fabriker A/S  
MR. LEIF RISELL

## DOMINICAN REPUBLIC

Leisure Time Records  
MR. DANIEL BRUYLANT

## ENGLAND

The Decca Record Company, Ltd.  
MR. GEOFFREY MILNE

MCA Records, Ltd.  
MR. JOHN ROBINSON

## EUROPE (Uni only)

Philips' Phonographic Industries  
MR. WIM SCHIPPER

## FINLAND

AB Discophon Oy  
MR. JOHAN VIKSTEDT

## FRANCE

La Compagnie  
MR. NORBERT SAADA

## GERMANY

MCA Records, GmbH  
MR. NORMAN DOUGLAS

## HOLLAND

Inelco-Holland, N. V.  
MR. WIM BRANDSTADER

## HONG KONG and SINGAPORE

The Life Records Ltd.  
MR. NG LIAN CHIN

## ITALY

MCA Records Italiana  
MR. DAVIDE MATALON

## JAMAICA and TRINIDAD

International Recording Company, Ltd.  
MR. LESLIE C. D. LUCKY-SAMAROO

## JAPAN

Victor Company of Japan, Ltd.  
MR. A. TORIO

## MEXICO

Orfeon Videovox, S. A.  
MR. LUIS SAN MARTIN

## MIDDLE EAST

MCA Records Ltd.  
MR. ISSAM HAMAOU

## NORWAY

A/S Disco  
MR. EILIF MEYER

## PHILIPPINES

Home Industries Development Corporation  
MR. ANTONIO U. LUSTRE

## SOUTH AFRICA

Gallo (Africa) Ltd.  
MR. ALEC DELMONT

## SPAIN

Discos Movieplay S. A.  
MR. CARLOS GUITART

## SWEDEN

Grammofon AB Eiectra  
MR. SIXTEN ERIKSSON

## SWITZERLAND

Phonag Schallplatten AG  
MR. HELMUT BISCHOF

## UNITED STATES

MCA Records International  
MR. RICHARD L. BRODERICK  
MR. F. N. SWENSON

## URUGUAY

Palacio de la Musica  
MR. ALFREDO AVIOTTI

## VENEZUELA

Metronome, C. A.  
MR. RUSSELL C. BOWEN

**MCA RECORDS**



MCA Records International  
A Division of MCA, Inc.

# GIANTS

## SWEDEN

"Maxwell's  
Silver Hammer"

GEORGE HOWE

#6

## HOLLAND

"Viva Tirado"

EL CHICANO

#9

## SOUTH AFRICA

"Holy Holy"

NEIL DIAMOND

#2

## SPAIN

"Save The Last Dance  
For Me"

JOHN ROWLES

#6

"Soolaimon"

NEIL DIAMOND

#8

## ARGENTINA

"Airport  
Love Theme"

VINCENT BELL

#10

## MEXICO

"Ebb Tide"

EARL GRANT

#8

## ENGLAND

"Hello, Darlin'"

CONWAY TWITTY

#8

## GERMANY

"Santa Fe  
auf Wiederseh'n"

JOSEF LAUFER

#9

## ENGLAND

"Tracy"

THE CUFF LINKS

#6

"Wings Upon  
Your Horns"

LORETTA LYNN

#3

## BRAZIL

"Superstar"

MURRAY HEAD

#1

"When Julie  
Comes Around"

CUFF LINKS

#9

MCA RECORDS



MCA Records International  
A Division of MCA, Inc.

Over 150 Chart Listings in the  
First 6 Months of 1970 —

Watch Your Local Trade Papers For Futures

# COMPO-CANADA

REPRESENTING THIS COUNTRY'S GIANTS:



# AND THERE'S ROOM FOR MORE!

CONTACT: LEE ARMSTRONG  
THE COMPO COMPANY LIMITED  
MCA BUILDING, 2450 VICTORIA PARK AVE.  
WILLOWDALE 425, ONTARIO, CANADA  
PHONE: 416-491-3000, TELEX: 02-29151

## ENGLAND: The Past 12 Mos.

(Con't. from Page 4)

Warner Brothers and other temporarily getting in on the act with counter bids and approaches. Bill Martin, Phil Coulter, Les Reed, Mitch Murray, Peter Callander, Barry Mason and the Scaffold were amongst those honored in the Ivor Novello Awards; two musicals "Belle Starr" and "Ann Veronica" folded; Nems took over the Brian Morrison Agency and Screen Gems-Columbia did a worldwide deal with Richard Harris' Limbridge Music.

In JUNE rumblings of discontent gathered force within the BBC particularly on the subject of staff orchestras reported destined for the redundancy axe but later reinstated after Musicians' Union intervention. The month came to a close with EMI Chairman Sir Joseph Lockwood announcing his intention to relinquish his duties as chief executive in November on the occasion of his sixty-fifth birthday while retaining his chairmanship. The new progressive label, Harvest, was launched in Britain in June and quickly established itself as an important reflection of the current musical scene. RCA launched its new disk promotion department under Tommy Loftus with a champagne reception and the Rolling Stones disclosed plans for some concerts in Rome as well as the fact that Brian Jones had left and been replaced by Mick Taylor. Warner Bros-Seven Arts took possession of its London home in New Oxford Street headed by Ian Ralfini and the Matings concert hall at Snape, annual venue for the Aldeburgh Festival was gutted by fire.

JULY opened with the news of Pye Records' major entry into the American market via a new company jointly owned with the GRT Corporation. BBC bother continued with heated dissent from some quarters on its plans for forty local radio stations, a formidable counter to commercial radio projects envisaged with a change of government at Westminster. In a surprise move, the British Phonographic Industry organisation representing the country's major disk manufacturers decided to abandon its case for the retention of resale price maintenance, opening the door to price cutting. MCA Records reverted to its licensing deal with Decca after a period of independence, but retained its own London office under Brian Broly. EMI Records sales director John Fruin was named merchandising director and disk jockey Chris Denning became Decca director of radio and television promotion in succession to Selwyn Turnbull, who took up the new post of artist and management liaison manager. Hassle broke out between UA Films and Sir William Walton because the company commissioned Ron Goodwin to write major part of "Battle of Britain" score, for which Sir William was originally assigned. The Beatles exited from Nems Enterprises, the company of their late manager Brian Epstein, in a settlement with Triumph Investment Trust. The BBC published its future radio plans, confirming fears that several orchestras were for the chop, and Pye Records chief Louis Benjamin named budget line and special projects head Monty Presky director of the company. Page One label chief Larry Page sold his interest in the enterprise to his partner Dick James and announced the formation of Penny Farthing Records.

AUGUST began with Pye capturing exclusive licensing rights for the U.K. and Ireland for Festival Records, the newly established British subsidiary of the Australian firm of the same name which is part of newspaper magnate Ruper Murdoch's business empire. EMI acquired Rediffusion's stake in the Keith Prowse-Peter Maurice music publishing group and Steve Gottlieb was named Philips-Polydor supremo in Britain. RCA made Ian Gillespie its product and operations general manager and Walter Sparksman its general marketing manager while MGM's British disk

## GREAT BRITAIN'S RECORD DISTRIBUTORS

**ASSOCIATED RECORDINGS COMPANY**  
326 Kensal Road  
London W.10

**E.M.I. RECORDS**  
(THE GRAMOPHONE CO. LTD.)  
80, Blyth Road, Hayes, Middlesex  
4a, Ford Park Lane, Mutley, Plymouth, Devon

**KEITH PROWSE (WHOLESALE) LIMITED**  
117B Fulham Road  
Chelsea  
London S.W.3

**PHILIPS RECORDS (SALES) LTD.**  
P.O. Box 90, 17, Beddington Farm Road,  
Croyden, Surrey.  
P.O. Box 450, 18, Lloyd Street, Manchester 2  
Highland House, 58, Waterloo Street, Glasgow C.2,  
Scotland

**POLYDOR RECORDS LTD.**  
17-19, Stratford Place  
London WIN OBL

**PYE RECORDS (SALES) LTD.**  
132, Western Road, Mitcham, Surrey.  
Ralli Buildings, Salford 3  
9a, Upper Accommodation Road, Leeds 9  
Nest Factory, Unit No. 21C, Carbrain Industrial  
Estate, Cumbernauld, Glasgow.  
1a, Dora Road, Small Heath, Birmingham.  
24, Mountjoy Square, Dublin 1

**SELECTA**  
(A Division of Decca Records Co. Ltd.)  
50, Southwark Bridge Road, S.E.1  
Pollokshaws, Glasgow S.3  
Failsworth, Manchester  
Earl Shilton, Leicester

**SOLOMON & PERES**  
67-69 Ann Street, Belfast 1, Ireland  
2, Dame Street, Trinity Lane, Eire, Ireland

**H.R. TAYLOR (BIRMINGHAM) LTD.**  
34, Pershore Street,  
Birmingham 5

operation reverted to a licensing deal with EMI once again. Campbell Connelly Music revealed plans to launch its own Concord label and Philips and Polydor readied massive fall campaign on cassettes.

The agreement between EMI and Tamla/Motown for Britain was renewed for a further long period at the beginning of September and staff changes at Philips resulted in Olav Wyper becoming marketing manager after service with CBS and producers Jack Baverstock and Terry Brown leaving. CBS announced its entry into the musical instrument and accessories market and increased involvement in the tape field at its regional sales conferences. Decca also forecast its entry into the tape market via cassettes at a later date and bowed a new budget line called Eclipse and details of its deal with the Moody Blues' new Threshold label. A huge open-air festival on the Isle of Wight with Bob Dylan headlining passed off with only minor incidents. Philip Solomon's Major Minor label set a three year deal with the French Barclay company and EMI announced its Regal Starline budget series. Former Radio Caroline pirate chief Ronan O'Rahilly gave details of his projected TV pirate station to be located in an aircraft flying over the North Sea, and the Management Agency and Music enterprise of Tom Jones, Engelbert Humperdinck and their manager reached dizzy new heights of success in the stock market. Pye chief Louis Benjamin referred to the unrealistic attitude of artists and managers on the question of advances during the Pye sales conference and said British industry was becoming more like Las Vegas every day in terms of risk. Pye took the Delyse label headed by Isabella Wallich and specialising in children's records and ethnic music under its administrative wing.

OCTOBER marked the increased interest at Philips in the indie production market by the signing of a deal with Monty Babson of Morgan Studios, producers of the Blue Mink hit "Melting Pot." AIR London head and Beatle producer George Martin set plans for the company's own recording studios to be located at London's Oxford Circus. Norrie Paramor ended a 20 year association with EMI, and set up independently with a Polydor affiliation. Elektra named Clive Sel. The nineteen seventies are tipped as the decade of the tape explosion in Britain and Europe generally. Cartridges and cassettes are expected to

(Con't. on Page 21)

## AUDIO — VISUAL COPYRIGHTS: A Situation Without Precedent In England

bite deeply for an ever-growing share of the music market, and just around the corner is the audio-visual device, enabling video performances to be seen and heard through television receivers.

This latter development will be a slow starter in domestic terms on account of its heavy cost. But the British music business anticipates an initial hiring system until the audio-visual branch of entertainment comes within reach of the pockets of the general public for use in their own homes.

### Copyright View

Dick James of Northern Songs has been pondering the resultant circumstances from a copyright point of view. The advent of audio-visual systems poses a situation without precedent, and James wants the matter of royalties and copyright protection to be defined and settled at the outset.

"Don't get me wrong," he said. "I'm not disturbed or opposed to these developments. I think they are fantastic and inevitable, and I welcome them, although they'll probably give the cinema and television something to worry about."

"I know several expert bodies already have the copyright and royalty aspects under consideration, and they're as aware as I am about all the angles. But now is the time to get the whole matter ironed out and regularised in readiness."

James referred to the long-standing statutory royalty rate of 6¼% for a double-sided record or tape established in 1928 and unvaried ever since.

"We're still living with that rate," he commented. "Overheads have in-

creased, so has the cost of living, and the value of money has decreased. Consequently a hit now is actually worth less than it would have been in 1928."

Like everyone else involved, he obviously would like to see this royalty rate raised, and raised in time to meet the audio-visual development in the market. James has ideas on how royalties could be collected.

### German Answer

"I believe that in Germany the price of video sound tape incorporates royalties for publishers with material used on the tape. Alternately I think people should buy a performing license with their audio-visual machines which is renewable each year like the one we have now for radio and TV receivers unless it is proved that the machine is no longer owned or in use."

This remedy would overcome the impossibility of the Performing Right Society licensing every individual household. Audio-visual equipment employed regularly for non-domestic private performances could be licensed by the PRS in the same way applied to music societies giving record recitals now.

James's hope for clarification and formulation of rates and safeguards for this new entertainment medium is strengthened by recent experience. The Ivor Novello Awards show was filmed for closed circuit TV in the States, and it was not until after the event that it was realised that this was the first international closed circuit project of its kind, and no copyright royalty basis had been set to cover it.

THE MOST EFFECTIVE  
MUSIC PUBLISHING HOUSE  
IN LONDON

**SUNBURY  
MUSIC LTD.**  
and its associates

AQUARIUS MUSIC LTD  
CASUAL MUSIC LTD  
BUZZ MUSIC LTD  
GROOVY MUSIC LTD  
PENNINE MUSIC LTD  
SUNSHINE MUSIC LTD  
CLODAGH MUSIC LTD

at

**1, DERBY STREET  
LONDON, W. 1**

Telephone: 01-493-9772

# BRITISH ARTISTS & COPYRIGHTS TO ENTER AMERICAN TOP 100

Title	Artiste	British Publisher	American Publisher	British Label	American Label
Abergavenny A Brand New Me	Shannon Dusty Springfield	Mills Famous-Chappell	Mills Parabut	Philips	Heritage Atlantic
Ballad of John & Yoꝰo Barabajagal Baby Make It Soon	Beatles Donovan Flying Machine	Northern Southern Welbeck/Schroeder	MacLen Peer Southern January	Apple Pye Pye	Apple Epic Congress
Cold Turkey Come Together Come And Get It Come Into My Life	Plastic Ono Band Beatles Badfinger Jimmy Cliff	Northern Songs Harrisongs-Northern Northern Island	MacLen Harrisongs MacLen Irving	Apple Apple Apple Trojan	Apple Apple Apple A & M
Didn't We Delta Lady Don't Forget to Remember Don't Waste My Time Daughter of Darkness	Richard Harris Joe Cocker Bee Gees John Mayall Tom Jones	Carlin Corp. Alan Keen Abigail St. George Music Hush-A-Bye Carlin	Ja-Ma Skyhill Casserole Felsted	RCA Regal Zonophone Polydor Polydor Decca	Dunhill A & M Atco Polydor Parrot
Early in the Morning Eleanor Rigby	Vanity Fare Aretha Franklin	Morris/Shaftesbury Northern	Duchess MacLen	Page One Atlantic	Page One Atlantic
Feeling Alright Give Peace A Chance Honky Tonk Women He Ain't Heavy, He's My Brother Hitchin' A Ride Hum A Song	Joe Cocker Plastic Ono Band Rolling Stones Hollies Vanity Fare Lulu	Island Music Northern Mirage Cyril Shane Intune	Almo Music Corp. MacLen Gideon Harrison Intune Walden	Regal Zonophone Apple Decca Parlophone Page One Atlantic	A & M Apple London Epic Page One Atco
In The Bad, Bad Old Days Imagine the Swan I'm Free I'll Never Fall In Love Again I Am A Better Man	The Foundations Zombies The Who Tom Jones Engelbert Humperdinck	Schroeder/Welbeck Marquis Music Fabulous Blues/Jac Blues Seas/Jac	January Mainstay Track Hollis Blue Seas	Pye Decca Decca Decca Decca	Uni Date Decca Parrot Parrot
I'm Tired Instant Karma If Only I Had My Mind On Something Else	Savoy Brown John Ono Lennon Bee Gees	Chrysalis Music Northern Abigail	Cool Waters MacLen Casserole	Decca Apple Polydor	Parrot Apple Atco
Look At Mine Let It Be Love Grows	Petula Clark Beatles Edison Lighthouse	Welbeck Northern Songs Mustard/Schroeder Mason	Leeds MacLen January	Pye Apple Bell	Warner Bros. Apple Bell
My Little Chickadee Midnight Cowboy No One Better Than You	Foundations Ferranti & Teicher Petula Clark	Welbeck/Schroeder United Artists Fluke Carlin	January Unart	Pye United Artists Pye	Uni U.A. Warner Bros.
Oh Me Oh My Oh Well (Part One)	Lulu Fleetwood Mac	Noo Trac Fleetwood	Noo Trac Fleetwood Mac	Atlantic Reprise	Atco Reprise
Question	Moody Blues	Tyler	Tro-Andover	Threshold	Threshold
Room To Move Reflections Of My Life	John Mayall Marmalade	Walrus	St. George/Mayall Walrus	Decca Decca	Polydor London
Something In The Air	Thunderclap Newman	Fabulous	Track	Track	Track
Something St. Louis Smile A Little Smile For Me She Came Through The Bathroom Window Silly Silly Fool	Beatles Easy Beats Flying Machine Joe Cocker Dusty Springfield	Harrisongs-Northern Welbeck/Schroeder Northern Carlin	Harrisongs Robbins January MacLen Assorted	Apple Pye Regal Zonophone Philips	Apple Rare Earth Congress A & M Atlantic
Tomorrow Tomorrow That's The Way God Planned It Temma Harbour The Seeker The Letter United We Stand	Bee Gees Billy Preston Mary Hopkin The Who Joe Cocker Brotherhood Of Man	Abigail Apple Rak Fabulous Belwin-Mills	Casserole Apple Major Oaks Track Earl Barton Belwin-Mills	Polydor Apple Apple Track Regal Zonophone Deram	Atco Apple Apple Decca A & M Deram
Victoria	Kinks	Davray/Carlin	Hill & Range	Pye	Reprise
Winter World Of Love	Engelbert Humperdinck	Donna	Donna	Decca	Parrot
Willie & Laura Mae Jones Whole Lotta Love Wonderful World Beautiful People Without Love	Dusty Springfield Led Zeppelin Jimmy Cliff Tom Jones	KPM Cop. Con. Island Valley	Combine Superhype Irving Tro Suffolk	Philips Atlantic Trojan Decca	Atlantic Atlantic A & M Parrot

## THE ROBERT MELLIN LTD.

GROUP OF COMPANIES

24, PARKSIDE, KNIGHTSBRIDGE,  
LONDON, S.W.1.

Telephone: 01-245-9026/7/8/9 Cables: MELLINMUS, LONDON, S.W.1.

## FRANKLYN BOYD MUSIC LTD.

BLUE SEAS MUSIC LTD.  
JAC MUSIC CO. LTD.  
STANYAN MUSIC LTD.

24, PARKSIDE, KNIGHTSBRIDGE  
LONDON, S.W. 1.

Telephone: 01-245-9026/7/8/9  
Cables: MELLINMUSIC LONDON, S.W. 1.

In any language

**EMI**

means record business

Die Grösste Schallplatten-Organisation der Welt

*Diînyamin en bûyûik seda kaydi organizasyonu*

De grootste grammofoonplatenmaatschappij der wereld

La più grande organizzazione discografica del mondo

*La plus grande compagnie mondiale de disques*

Ο ΜΕΓΑΛΥΤΕΡΟΣ ΟΡΓΑΝΙΣΜΟΣ ΗΧΟΓΡΑΦΗΣΕΩΝ ΤΟΥ ΚΟΣΜΟΥ

Verdens største plade-organisation

*La mayor organización mundial de discos*

Världens största skivproducent



**EMI**

– the greatest recording organisation in the world

# GREAT BRITAIN'S RECORD MANUFACTURERS

## A & M RECORDS LTD.

Steinway Hall  
1/2 St. George Street  
London W.1  
Tel.: 01-493 1693/4/5/6  
Managing Director: Lawrence M. Yaskiel  
Labels: A & M, Shelter, Ode

## APPLE CORPS LTD.

3 Savile Row  
London W.1  
Tel.: 01-734-8232  
Managing Directors: J. O. Lennon, G. Harrison  
Label: Apple

## ARGO RECORD COMPANY

115, Fulham Road  
London S.W. 3  
Tel.: 01-589-5293  
Managing Director: H. J. Usill  
Label: Argo

## AURORA

15, Berkeley Street,  
London W.1  
Tel.: 01-493-2506  
Manager: Arthur Crisford  
Label: Aurora

## BEACON RECORDS LTD.

Head Office:  
331-333, Willesden High Road  
London N.W.10  
Tel.: 01-459-2333  
Promotion Department:  
51, Charles Street  
London W.1  
Tel.: 01-499-3741  
Managing Director: Milton Samuel  
Labels: Beacon, Upfront, Young Blood.

## B & C RECORDS LTD.

37, Soho Square  
London W.1  
Tel.: 01-734-3932  
Managing Director: Lee Gopthal  
Labels: B & C, Charisma, Action, Stable, Trojan

## DR. BIRD RECORDS

117c, Fulham Road  
London S.W.3  
Managing Director: Graham Goodall  
Labels: Dr. Bird, Pyramid, Attack

## BELL RECORDS

23, Old Burlington Street,  
London W.1  
Tel.: 01-734-3265  
Managing Director: Trevor Churchill  
Labels: Bell

## BLUE HORIZON LIMITED

30, St. George Street  
Hanover Square  
London W.1  
Tel.: 01-499-9477  
Chairman & Producer: Mike Vernon  
Managing Director: Richard Vernon  
Label: Blue Horizon

## CARNABY RECORDS

45, 46 Chandos Place  
London W.C. 2  
Tel.: 01-836-7255  
Managing Director: Mervyn Conn  
Labels: Carnaby, Nashville

## CBS RECORDS

28/30, Theobalds Road,  
London WC1X 8PB  
Tel.: 01-242-9000  
Managing Director: Ken Glancy  
Labels: CBS, Direction, Blue Horizon, Dandelion,  
Straight, Aurora, Dolphin.

## CHAPTER ONE

138/140 Charing Cross Road  
London W.C. 2  
Tel.: 01-836-9351  
Managing Director: Les Reed  
Label: Chapter One

## CHRYSALIS RECORDS

155/157, Oxford Street,  
London W.1  
Tel.: 01-734-9233  
Managing Directors: Terry Ellis & Chris Wright  
Label: Chrysalis

# ENGLAND'S FASTEST EXPANDING LABEL EVOLUTION

We are a truly independent record company. Our catalogue has a variety of music from pop and underground to blues and folk.

Enquiries for licensing apply:

Managing Director

**EVOLUTION RECORDS**  
63 Old Compton Street  
London W1A 4NB  
Tel: 01-734-5156

## THE DECCA RECORD COMPANY LIMITED

Decca House  
9, Albert Embankment  
London S.E.1  
Tel.: 01-735-8111  
Chairman: Sir Edward Lewis  
Director: W.W. Townsley  
Labels: Decca, Deran, Ace of Clubs, Ace of Diamonds,  
London, London Globe, Brunswick, Ace of Hearts,  
L'Oiseau Lyre, Vox, Turnabout, Argo, Telefunken, Voca-  
lion, Emerald, Contemporary, Godd Time Jazz, Bel-  
tona, Rex, Chapter One, Qualiton, Wand, MCA, Coral,  
Eclipse, Sugar, Threshold.  
Distributors of: Challenge, Staday, American London  
Group, Jamie, Hickory, Laurie, Pompeii, Amos, Main-  
stream, Ranwood, Seven B, Scepter, Steady, Sound  
Stage 7.

## DELYSE RECORDING CO. ENVOY RECORDING CO. LTD.

ATV House  
17, Great Cumberland Place  
London W.1  
Tel.: 01-262-5502  
Managing Director: Mrs. Isabella Wallich  
Labels: Delyse, Envoy

## WALT DISNEY PRODUCTIONS LTD.

83, Pall Mall  
London S.W.1  
Tel.: 01-839-8010  
European Director: Frank Weintrop  
Labels: Buena Vista, Disneyland.

## D.J.M.

James House  
71, 75, New Oxford Street  
London W.C.1  
Tel.: 01-836-4864  
Managing Director: Stephen James  
Label: DJM

## EMBER RECORDS

Carlton Tower Place,  
Sloane Street,  
London S.W.1  
Tel.: 01-245-9339 01-245-9330 01-235-7631  
Managing Director: Jeffrey Kruger  
Labels: Ember, Famous Artists, Speciality  
Distributors of: Circa, Ambassador, Sun, Avaral, LMI,  
Barclay, Kapp, Palette, Davon, Bethlehem, King, Star-  
day, Rondo, Flip, Everest, Kent Crown Roulette, Tico,  
Festival Roost, Nashville P & S, Speciality, Tradition,  
Vedette, & specialised material from Sky, Capitol,  
People.

## EMERALD RECORDS LTD.

67/69, Ann Street  
Belfast 1  
Northern Ireland  
Tel.: 0232-31616  
President: Mervyn A. Solomon  
Labels: Emerald, Gem, Great Bands, M & M

## E.M.I. RECORDS

E.M.I. House, 20, Manchester Square  
London W1A 1ES  
Tel.: 01-486 4488  
Managing Director: P. Brodie  
Labels: H.M.V., Capitol, Columbia, Parlophone, Regal,  
Zonophone, Harvest, Waverley, Encore, Stateside, Bell,  
Commodore, Dot, Paramount, Impulse, Stax, Tamla  
Motown, M.G.M., Conquest, Verve, Probe, Regal Star-  
line, Talisman, Rak.  
Distributors of: A.B.C. (Bluesway), T-Neck, Amaret,  
Hobbit, Project 3, Invictus, Musicor, Blue Thumb,  
Dunhill, 20th Century Fox, Westminster.

## ENTERPRISE RECORDS

83, Lyndhurst Gardens  
London N.3  
Tel.: 01-346-7079  
Managing Director: Michael Moores & John Watson  
Label: Enterprise

## EVOLUTION RECORDS

63, Old Compton Street  
London W.C. 2  
Tel.: 01-734-5156  
Managing Director: M. Zackariya  
Label: Evolution

## FAMOUS MUSIC (UK) LIMITED

162/170, Wardour Street,  
London W.1  
Tel.: 01-437-7700  
Managing Director: Leslie Gould & Ralph Mace  
Labels: Paramount, Dot, Stax, Volt

## GEMINI RECORDS LTD.

1, Westbourne Gardens,  
London W.2  
Tel.: 01-229-3411  
Directors: D.A.S. Dane & E. Kassner  
Label: Gemini

## HEAD RECORDS LTD.

25, South Molton Street  
London W.1  
Tel.: 01-629-6391  
Managing Director: John Curd  
Labels: Head, Buffalo, Blues Power

## ISLAND RECORDS

8/10, Basing Street,  
London W.11  
Tel.: 01-229-1229  
Sales:  
Music House  
12, Neasden Lane  
London N.W. 10.  
Tel.: 01-459-6212  
Managing Director: Christopher Blackwell  
Labels: Island, Trojan  
Distributors of: Chrysalis, B & C, Charisma

## JUPITER RECORDINGS LTD.

140, Kensington Church Street  
London W.8  
Tel.: 01-229-9531  
Directors: V.C. Clinton-Baddeley, Wallace Southam,  
Edgar Vetter.  
Label: Jupiter.

## LEOMARK LTD.

Winchester House  
77, London Wall  
London E.C.2  
Tel.: 01-588-1815

## LIBERTY/UA RECORDS LTD.

37/41, Mortimer Street  
London W1A 2JL  
Tel.: 01-636-1655  
Managing Director: Martin Davis  
Company Secretary: John Barklem  
Labels: Liberty, United Artists, Sunset, Blue Note.  
Distributors: Imperial, World Pacific, Pacific Jazz, Solid  
State, Tale Spinners, UA-Latino, UA-International,  
Mimit, Fantasy, Galaxy, Vault.

## MAJOR MINOR RECORDS LTD.

58/59, Gt. Marlborough Street  
London W.1  
Tel.: 01-437-5803  
Managing Director: Philip Solomon  
Labels: Major Minor, Toast, Roulette, Jad.

## M.C.A. RECORDS LTD.

139, Piccadilly,  
London W.1  
Tel.: 01-629-7211  
Managing Director: Brian T. Broly,  
Labels: M.C.A., Uni

## MGM RECORDS LTD.

64, Dean Street  
London W.1  
Tel.: 01-437-9336

## MUSIC FOR PLEASURE LTD.

Astronaut House  
Hounslow Road  
Feltham  
Middlesex  
Tel.: 01-751-8400  
Managing Director: Richard Baldwin  
Label: Music for Pleasure

## ORANGE RECORDS

3/4, New Compton Street  
London W.C.2  
Tel.: 01-836-7811  
Managing Director: Cliff Cooper  
Label: Orange

## PAGE ONE RECORDS LIMITED

James House  
71/75, New Oxford Street  
London W.C.1  
Tel.: 01-836-4864  
Directors: Stephen James & Dennis Berger  
Label: Page One

## PAMA RECORDS

78, Craven Park Road  
London N.W.10  
Tel.: 01-965-2207/8/9  
Managing Director: C.H. Palmer  
Labels: Crab, Gas, Unity, Ocean, Newbeat, Punch,  
Ballet, Escort, PAMA, Economy Supreme, Import

## PENNY FARTHING RECORDS LTD.

4, Tiline Street  
Park Lane  
London W.1  
Tel.: 01-493-8873  
Managing Director: Larry Page  
Label: Penny Farthing

## PHILIPS RECORDS LTD.

Stanhope House  
Stanhope Place  
London W.2  
Tel.: 01-262-7788  
Managing Director: Fred Marks  
Labels: Philips, Fontana, Mercury, Caedmon, Vanguard,  
Vertigo, Nashville.  
Distributors of: Page One, Island, Liberty, Penny Far-  
thing

## PICKWICK INTERNATIONAL INC. (GREAT BRITAIN) LTD.

Victoria Works  
Edgware Road,  
Cricklewood  
London N.W.2  
Tel.: 01-450-7746  
Managing Director: Monty Lewis  
Labels: Happy Time, RCA Camden, Hallmark, Al-  
legro, Pickwick Cassettes

## PLEXIUM RECORDS

9 Oxford Circus Avenue,  
London W.1  
Tel.: 01-437-2434  
Managing Director: Gordon Lotinga  
Label: Plexium

## POLYDOR RECORDS LTD.

17/19, Stratford Place  
London W.1N 0BL  
Tel.: 01-499-8686  
Managing Director: John Fruin  
Labels: Polydor, 99, Deutsche Grammophon, Archive  
Production, Avant Garde, Debut, Heliodor Historical,  
Heliodor Wergo, Musique Royale, Nonesuch, Privilège,  
Atlantic, Atco, Buddah, Clan, Elektra, Kama Sutra,  
Riverside, Storyville, Track.

## PRESIDENT RECORDS LTD.

1, Westbourne Gardens  
London W.2  
Tel.: 01-229-3411  
Directors: D.A.S. Dane & E. Kassner  
Labels: President, Jayboy, Crystal, Joy.

## PYE RECORDS LIMITED

A.T.V. House  
Great Cumberland Place  
London W.1  
Tel.: 01-262-5502  
Managing Director: Louis Benjamin  
Labels: Pye Popular, Pye International, Dawn, Golden  
Guinea, Marble Arch, Hispavox, Crewe, A & M, Chess  
Carnaby, D.J.M., Head, Lucky, Middle Earth, Spark,  
Trend, Virtuoso, Delyse, Collector, Envoy, Pama,  
Disney, Buena Vista, Reprise, Warner Bros.  
Distributors of: A & M, B.T. Puppy, Disneyland, Buena  
Vista, D.J.M., Domino Durium, Head, Buffalo, Mencap,  
Orange, Reprise, Spark, Teepee, Warner Bros.

## REVOLUTION RECORDS

490A, Old Kent Road  
London S.E.1  
Tel.: 01-237-1738  
Managing Director: D.A. Hadfield  
Label: Revolution

## R.C.A. LIMITED RECORD DIVISION

RCA House  
50/52, Curzon Street  
London W.1  
Tel.: 01-499-3901  
Managing Director:  
Labels: RCA, Red Seal, Victor, Victrola

## REDIFFUSION INTERNATIONAL MUSIC

2/16, Goddage Street  
London W1P 1FF  
Tel.: 01-580 9506  
General Manager: W.A. Fenton  
Label: Rediffusion

## SAGA RECORDS LTD.

326, Kensal Road  
London W.10  
Tel.: 01-523-6651  
Managing Director: Marcel Rodd  
Labels: Eros, Language Records, Opp, Psyche, XID

## 77 RECORDS

77, Charing Cross Road  
London W.C.2  
Tel.: 01-437-4197  
Managing Director: Doug Dobell  
Labels: 77, Folklore, Swift

## SONET PRODUCTIONS LTD.

37, Soho Square  
London W.1  
Tel.: 01-437-0806  
Managing Director: Rod Buckle  
Label: Sonet

## SPARK RECORDS

8, Denmark Street  
London W.1  
Tel.: 01-836-4524  
Managing Director: Freddie Poser  
Label: Spark

## SPIN RECORDS LTD.

Dunville Buildings,  
Adelaide Street  
Tel.: Belfast 21939 21465  
Managing Director: R. Gordon Smyth  
Label: Spin

## SUGAR RECORDS

64, South Molton Street  
London W.1  
Tel.: 01-499-5781  
Label: Sugar

## TALENT RECORD CO.

76, Bedford Court Mansions  
Bedford Avenue  
London WC1B 3AE  
Managing Director: Carlo Krahmer  
Label: Delmark

## TEAL RECORDS COMPANY

19, Cumberland Mansions  
George Street  
London W.1  
Managing Director: Ray Walter  
Tel.: 01-262-2936  
Label: Teal

## TABOO RECORDS LTD.

ATV House  
Gt. Cumberland Place  
London W.1  
Tel.: 01-262-5502  
General Manager: David Paramor  
Label: Taboo

## THRESHOLD RECORDS

8, Rathbone Place  
London W.1  
Tel.: 01-636-2034  
Managing Directors: Moody Blues  
Label: Threshold

## TOPIC RECORDS LTD.

27, Nassington Road  
London N.W.3  
Tel.: 01-229-3411  
Managing Director: G. Sharp  
Labels: Topic, Impact

## TORPEDO RECORDS LTD.

1, Westbourne Gardens,  
London W.2  
Tel.: 01-229 3411  
Directors: D.A.S. Dane & E. Kassner  
Label: Torpedo

## TRACK RECORDS

70, Old Compton Street  
London W.1  
Tel.: 01-437-9506  
Directors: Kit Lambert, Chris Stamp, Peter Kameron  
Label: Track

## TRANSATLANTIC RECORDS LTD.

86, Marylebone High Street  
London W.1  
Tel.: 01-486-4353  
Managing Director: Nathan Joseph  
Labels: Transatlantic, Xtra, Sonet, Big T, Everest.  
Distributors of: Folkways, Conversaphone, Ya 200

## TREND RECORDS

Classic House  
113, Westbourne Grove  
London W.2  
Tel.: 01-727-3506  
Managing Director: Barry Class  
Label: Trend

## UPC RECORDS

35, Portland Place  
London W.1  
Tel.: 01-580-2000  
Managing Director:  
Label: UPC

## WARNER BROS. RECORDS LTD.

69, New Oxford Street  
London W.C.1  
Tel.: 01-836-9381  
Managing Director: Ian Ralfini  
Labels: Warner Brothers, Reprise, Valiant.

## WORLD RECORD CLUB

Parkbridge House  
Little Green  
Richmond, Surrey  
Tel.: 01-940-8331  
General Manager: C. P. Hadley  
Labels: World Record Club, Conquest, WRC

## YOUNG BLOOD RECORDS

138, New Bond Street  
London W.1  
Tel.: 01-493-9681  
Managing Director: Miki Dallon  
Label: Young Blood

## ZEL RECORDS

63, Old Compton Street  
London W.C.2  
Tel.: 01-743 5156/7  
Managing Director: M. Zackariya  
Labels: Zel, Evolution, Golden Discs Club



The  
**Decca Record  
Company Limited**  
of England

and its USA subsidiary  
**London Records Inc.**

offer American record  
labels a first-class  
world-wide  
distribution service.

Decca House 9 Albert Embankment London SE1 England

# GREAT BRITAIN'S MUSIC PUBLISHERS

## ACTIVE MUSIC LTD.

(Marina Music)  
(Zig Recording Co.)  
142, Charing Cross Road  
London W.C.2  
Tel.: 01-836-3992

## AMBASSADOR MUSIC LTD.

(Ambassador Seven Arts Ltd.)  
(Cash Songs Pub. Co.)  
(Damon Music Corp.)  
(George Pincus & Sons Music Corp.)  
(Giant Music Pub. Co. Ltd.)  
(Gil Music Corp.)  
(In Music Co.)  
(John Lee Hooker Music Corp.)  
(Pin-Tar Music Inc.)  
(RHM Music Ltd.)  
(Shifting Flowers Music Corp.)  
(Songfest Music Corp.)

23/24, Greek Street  
London W1V 5LG  
Tel.: 01-437-7053

## APPLE PUBLISHING LIMITED

3, Savile Row  
London W.1  
Tel.: 01-734-8232

## APEX MUSIC CO.

12, Elgin Mansions  
Elgin Avenue  
London W.9  
Tel.: 01-629-0686

## ACUFF-ROSE MUSIC LTD.

15, St. George Street  
Hanover Square  
London W.1  
Tel.: 01-629-0392

## APOLLO MUSIC LTD.

(Solihiull Music Ltd.)  
(Trelion Music Co. Ltd.)  
37 Soho Square  
London W.1V 5DG  
Tel.: 01-734-3835

## APRIL MUSIC LTD.

1, Wardour Street  
London W.1  
Tel.: 01-439-1845

## ARCADIA MUSIC PUBLISHING CO. LTD.

(Polyphone Music Co. Ltd.)  
(Swan & Co. Ltd.)  
10, Sherlock Mews  
London W.1M 3RH  
Tel.: 01-935-5469

## ARDMORE & BEECHWOOD LTD.

(Ambleside Music Ltd.)  
(Black Swan Music (London) Ltd.)  
(Britten Music Ltd.)  
(Coppa Music Ltd.)  
(First Floor Music Ltd.)  
(Hunter Music Ltd.)  
(Initial Music Ltd.)  
(Mutual Music Co. Ltd.)  
(Manhattan Music Ltd.)  
(Pepe Music Ltd.)  
(Tribune Music Ltd.)

## ARDMORE & BEECHWOOD LTD. (Con't.)

(Varda Music Ltd.)  
21, Denmark Street  
London W.C.2  
Tel.: 01-836-3856 & 5501

## EDWIN ASHDOWN LTD.

15, Hanover Square  
London W1A 4DR  
Tel.: 01-629-1184

## FRANKLYN BOYD MUSIC LTD.

(Blue Seas Music Ltd.)  
(Jac Music Co. Ltd.)  
(Stanyan Music Ltd.)  
24, Parkside  
Knightsbridge  
London S.W.1  
Tel.: 01-245-9026/7/8/9

## BELWIN-MILLS MUSIC LTD.

(Mills Music Ltd.)  
(Multimood Music Ltd.)  
(Mills-Broadoak Music Ltd.)  
(Mills-Candle Music Ltd.)  
(Paradise Music Ltd.)  
20, Denmark Street,  
London W.C.2  
Tel.: 01-240-1745

## BOOSEY & HAWKES MUSIC PUBLISHERS LTD.

(Anglo-Soviet Music Press Ltd.)  
(Boosey & Co. Ltd.)  
(Cavendish Music Co. Ltd.)  
(Edition A. Gutheil)  
(Editions Russe de Musique)  
(Hawkes & Son (London) Ltd.)  
(J.R. Lafleur & Son Ltd.)  
(Rudall, Carte & Co. Ltd.)  
(Winthrop Rogers Ltd.)  
295, Regent Street  
London W.1A 1BR  
Tel.: 01-580 2060

## BOSWORTH & CO. LTD.

14/18, Heddou Street  
London W.1  
Tel.: 01-734-4961/2/3

## BOURNE MUSIC LTD.

(Aeolian Music Ltd.)  
34/36, Maddox Street  
London W.1R 9PD  
Tel.: 01-493-6412/6583

## BRON ASSOCIATED PUBLISHERS LTD.

(B.V.F. Anglo-Continental Music Co. Ltd.)  
(Sydney Bron Music Co. Ltd.)  
(Carrie Music Ltd.)  
(Debmar Pub. Co. Ltd.)  
(Hit Songs Ltd.)  
(Mann Music Pub. Ltd.)  
(Marklon Music Ltd.)  
(Pitney Music Ltd.)  
(Tony Hazzard Music Ltd.)  
(Yale Music Corp. Ltd.)  
29/31, Oxford Street  
London W.1  
Tel.: 01-437-5063

## BURLINGTON MUSIC CO. LTD.

(Palace Music Co. Ltd.)  
9, Albert Embankment,  
London S.E.1  
Tel.: 01-735-2692 & 01-942-7507

## THE CAMPBELL CONNELLY GROUP

(Berry Music Ltd.)  
(Cinephonic Music Co. Ltd.)  
(Cross Music Ltd.)  
(Dash Music Co. Ltd.)  
(Evergreen Music Co. Ltd.)  
(Harrison Music Co. Ltd.)  
(Hournew Music Ltd.)  
(Gauntlet Music Ltd.)  
(Ivy Music Ltd.)  
(Montclare Music Co. Ltd.)  
(Hans Sikorski Ltd.)  
(Show Music Ltd.)  
(Starlight Music Pub. Co. Ltd.)  
(Vincio Music Ltd.)  
10, Denmark Street  
London W.C.2  
Tel.: 01-836-1653

## CARLIN MUSIC CORPORATION

(Abacus Music Ltd.)  
(Alan Price Music Ltd.)  
(Amen Music Ltd.)  
(A.M.P. Music Ltd.)  
(Anita Music Ltd.)  
(Bee Bee Music Ltd.)  
(Benday Music Ltd.)  
(Camad Pub. Ltd.)  
(Cardinal Music Ltd.)  
(Chad & Jeremy Music Ltd.)  
(Coronet Music Ltd.)  
(Dabe Music Ltd.)  
(Davray Music Ltd.)  
(Design Music Ltd.)  
(Destiny Music Ltd.)  
(Early Bird Music Publishing Co. Ltd.)  
(Eddie Tre-Vett Music Ltd.)  
(Enquiry Music Ltd.)  
(Eric Burdon Music Ltd.)  
(Escort Music Ltd.)  
(Fiesta Music Ltd.)  
(Fortitude Music Ltd.)  
(Fluke Music Ltd.)  
(Fugal Songs Ltd.)  
(Gamble Huff Music Ltd.)  
(Gold Disc Music Ltd.)  
(Harmarlane Music Ltd.)  
(Helios Music Ltd.)  
(Hercules Music Ltd.)  
(Jack Good Music Publ. Co. Ltd.)  
(Joaneline Music Ltd.)  
(Jobete—Carlin Music Ltd.)  
(Jodrell Music Ltd.)  
(Jetstar Publishers Ltd.)  
(Johnny Devlin Music (London) Ltd.)  
(Johnny Mathis Music Ltd.)  
(Joker Music Ltd.)  
(Joker Two Ltd.)  
(Kalmann Music Ltd.)  
(Kenmoss Music Ltd.)  
(Kenny Lynch Music Ltd.)  
(Kevin Eggers Music Ltd.)  
(Kieron Music Ltd.)  
(Knox Music Ltd.)  
(Lark Music Ltd.)  
(Lee Hazlewood Music Ltd.)  
(Leiber-Stoller Songs Ltd.)  
(Linvoy Music Ltd.)  
(Ludix Music Ltd.)  
(Manor Music Co. Ltd.)  
(Marlyn Music Co. Ltd.)  
(Maycroft Music Ltd.)  
(Miki Dallon Music Ltd.)  
(Miracle Songs Ltd.)  
(Orange Publishing Ltd.)  
(Park Lane Music Co. Ltd.)  
(Peterman & Co. Ltd.)  
(Penjane Music (London) Ltd.)  
(Pulsar Music Ltd.)  
(Sam Songs Ltd.)  
(Semprini Music Ltd.)  
(Shadamm Music Ltd.)  
(Shadows Music Ltd.)  
(Slamina Music Ltd.)  
(Smooth Music Ltd.)  
(S.P.R. Music Ltd.)  
(Supreme Music Ltd.)  
(Swansong Music Ltd.)  
(Tarot Music Ltd.)  
(T.M. Music Ltd.)  
(Tim Hollier Productions Ltd.)  
(Tollak Music Co. Ltd.)  
(Tollie Music Ltd.)  
(Vicki Music Ltd.)  
(Warland Music Ltd.)  
(Waterloo Music Ltd.)  
17, Savile Row  
London W.1  
Tel.: 01-734-3251

## FRANK CHACKSFIELD MUSIC LTD.

(Eros)  
(Medway)  
(Senlac)  
"Allegro", Elm Walk,  
Farnborough  
Kent  
Tel.: Farnborough 55509

## CHAPPELL & CO. LTD.

(Acuff-Rose Music Ltd.)  
(Anglo-Pic Music Co. Ltd.)  
(Ascherberg, Hopwood & Crew Ltd.)  
(Larry Adler Music Ltd.)  
(Avenue Music Pub. Co. Ltd.)  
(Belafonte Music Ltd.)  
(Brittania Music Co. Ltd.)  
(Bondola Music Ltd.)  
(Irving Berlin Ltd.)  
(Bradbury Wood Ltd.)  
(Bregman Vocco & Conn Ltd.)  
(Carnaby Music Ltd.)  
(Chalet Music Ltd.)  
(Chanter Music Ltd.)  
(Chappell-Solomon Ltd.)  
(Clarence Music Ltd.)  
(Compass Music Ltd.)  
(Commair-Chappell Music Ltd.)  
(Continental Publications Ltd.)  
(Delfont Music Ltd.)  
(Walt Disney Music Co. Ltd.)  
(E.F.D.S. Publications Ltd.)  
(Empire Consul Music Ltd.)  
(Erle Music Ltd.)  
(Famous-Chappell Ltd.)  
(Frank Music Co. Ltd.)  
(Goodie Two Shoes Music Ltd.)  
(Grob-Chappell Music Co. Ltd.)  
(Hagen Music Ltd.)  
(International Music Co. Ltd.)  
(Ipanema Music Ltd.)  
(Jewel Music Pub. Co. Ltd.)  
(Joseph E. Levine Music Co. Ltd.)  
(L.J. Cary & Co. Ltd.)

## CHAPPELL & CO. LTD. (Con't.)

(Lissauer Music Ltd.)  
(Lowery Music Ltd.)  
(Le Vien Music Ltd.)  
(Keyboard Music Ltd.)  
(Maddox Music Co. Ltd.)  
(Majority Music Ltd.)  
(Magic Music Ltd.)  
(Midas Music Ltd.)  
(Michele Music Ltd.)  
(Minstrel Music Ltd.)  
(Edwin H. Morris & Co. Ltd.)  
(New World Music Ltd.)  
(New World Publishers Ltd.)  
(Paxwin Music Ltd.)  
(P.K. Music Ltd.)  
(Patricia Music Ltd.)  
(Terry Oates Publishing Ltd.)  
(Radview Enterprises Ltd.)  
(Rumbalero Music Ltd.)  
(Sterling Music Pub. Co. Ltd.)  
(Stratford Music Ltd.)  
(Ben Selvin Music Ltd.)  
(Valando Music Co. Ltd.)  
(Victoria Music Pub. Co. Ltd.)  
(Walton Music Ltd.)  
(Williamson Music Ltd.)  
50, New Bond Street  
London W.1  
Tel.: 01-629-7600

## J. & W. CHESTER LTD.

Eagle Court  
London E.C.1  
Tel.: 01-253-6947

## CONTACT MUSIC LTD.

39, Albemarle Street  
London W.1  
Tel.: 01-493-9595

## CRANZ & CO. LTD.

1, Montague Street  
London W.C.1  
Tel.: 01-636-5171

## CROMA MUSIC LIMITED

(Ashley-Fields Music)  
(Roncom Music Ltd.)  
63, Frith Street  
London W1V 6TA  
Tel.: 01-734-7462/3 & 01-734-5020

## DANVER MUSIC LTD.

(Joper Music Ltd.)  
(Tomorrow Music Co.)  
Suite 34  
Evelyn House  
62, Oxford Street  
London W.1  
Tel.: 01-580-8251

## DUNRAVEN MUSIC PUBLISHING CO. LTD.

28/30, Market Place  
London W.1  
Tel.: 01-580-9694

## ESSEX MUSIC LTD.

(Allegro Music Ltd.)  
(Concord Music Ltd.)  
(Cromwell Music Ltd.)  
(Durham Music Ltd.)  
(Essex Music International Ltd.)  
(Greenwich Music Ltd.)  
(Harmony Music Ltd.)  
(Jubilation Music Ltd.)  
(Kensington Music Ltd.)  
(Key Music Ltd.)  
(Lakeview Music Publ. Co. Ltd.)  
(London Tree Music Ltd.)  
(Majestic Music Ltd.)  
(Musical Comedy Productions Ltd.)  
(Romney Music Ltd.)  
(Rutland Music Ltd.)  
(Horizon Music Ltd.)  
(Tyler Music Ltd.)  
(Writers Workshop Ltd.)  
Dumbarton House  
68, Oxford Street  
London W.1  
Tel.: 01-636-7906

## EXPRESS MUSIC (LONDON) LTD.

Royal House  
1 & 2, Royal Parade  
Dawes Road  
London S.W.6  
Tel.: 01-385-5660

## FANFARE MUSIC CO. LTD.

(D.J. Music Ltd.)  
(Five Continents Music Co. Ltd.)  
(Klynch Music Ltd.)  
(Le Bill Music Ltd.)  
(Mason Music Ltd.)  
(Mondo Music Ltd.)  
(Tin Pan Alley Music Ltd.)  
(Tunetime Music Ltd.)  
(Altus Music Ltd.)  
100, Charing Cross Road  
London W.C.2  
Tel.: 01-836-8235 & 01-240-3691

## FAST BACK LTD.

12a, St. George Street  
London W.1

## B. FELDMAN & CO. LTD.

(Beacon Music Ltd.)  
(British & Continental Music Agencies Ltd.)  
(Charter Film Music Ltd.)  
(Dean Street Music Ltd.)  
(Dix Ltd.)  
(The Dreamers Music Co. Ltd.)  
(Gerrard Music Ltd.)  
(Henrees Music Ltd.)  
(Hermusic Ltd.)  
(Ivor Music Ltd.)  
(Jade Music Ltd.)  
(Kennedy Street Music Ltd.)  
(Herman Darewski Music Publishing Co.)  
(Manchester Music Ltd.)  
(Roar Music Ltd.)  
(Yardbirds Music Ltd.)  
64, Dean Street  
London W.1  
Tel.: 01-437-9336

## FILMUSIC PUBLISHING CO. LTD.

(Debonaire Music)  
(Medallion Music)  
(Pail Mail Music)  
110, Bond Street  
London W.1  
Tel.: 01-493-7633

## FLAMINGO MUSIC LIMITED

14, Berkeley Street  
London W.1  
Tel.: 01-499-4677-8

(Con't. on Page 16)



**THE WHO**  
**JIMI HENDRIX EXPERIENCE**  
**MARSHA HUNT**  
**THUNDERCLAP NEWMAN**  
**etc. etc.**

**70, OLD COMPTON STREET, LONDON W.1. Tel: 01-437-9506/9**  
**PROMOTION & PUBLICITY — VERNON BREWER Tel: 01-734-0853**  
**BOOKING AGENCY — PETE RUDGE Tel: 01-734-1395**



Home Of  
The World's **GREATEST HITS!**



**D.J.M.  
(DISTRIBUTORS) LIMITED**

**PAGE ONE  
RECORDS LIMITED**



JAMES HOUSE, 71 - 75 , NEW OXFORD STREET, LONDON, W.C.1. ENGLAND.  
Telephone:- 01-836-4864 (5 Lines) Cables ; DEJAMUS, LONDON, W.C.1. Telex; 27135

FOR USA, CANADA, MEXICO & THE PHILIPPINES  
DAVID ROSNER, SUITE 1200, 1780, BROADWAY, NEW YORK, N.Y. 10019

AEROFILMS LTD

# GREAT BRITAIN'S MUSIC PUBLISHERS

(Con't. from Page 14)

## FLORIDA MUSIC COMPANY LTD.

(Angel Music Co.)  
(Ember Mood Music Library)  
(Gloucester Music Pub. Co.)  
(Lorraine Music Co.)  
(Mark Music Pub.)  
(Monshana Music Pub. Co.)  
(Mood Music Pub. Co.)  
(Sharon Music Pub. Co.)  
(The Sparta Florida Music Group Ltd. Inc.)  
Executive Suite  
4, Carlton Tower Place,  
Sloane Street,  
London S.W.1  
Tel.: 01-245-9339

## FRANCIS DAY & HUNTER

(Bluebird Music Co.)  
(Donna Music Ltd.)  
(Magna Music Co. Ltd.)  
(Sun Music Pub. Co. Ltd.)  
138/140, Charing Cross Road  
London W.C.2  
Tel.: 01-836-9351

## FURSTNER LTD.

40, Hyde Park Gate  
Flat 6  
London S.W.7  
Tel.: 01-536-4383

## GALLIARD LTD.

(Augener)  
(Joseph Williams)  
(Weekes)  
Queen Anne's Road  
Gt. Yarmouth  
Norfolk

## GALE MUSIC LTD.

6, Southampton Place  
London W.C.1

## NOEL GAY MUSIC CO. LTD.

(Audley Music Ltd.)  
(Felicia Gay Music Co. Ltd.)  
(Gavel Music Co. Ltd.)  
(Larissa Music Co. Ltd.)  
(Glebe Music Co. Ltd.)  
(Nordic Music Co. Ltd.)  
(P & G Music)  
(Plantagnet Music Co. Ltd.)  
(Pudding Music Co. Ltd.)  
(Two Four Music Publishers Ltd.)  
(Wednesday Music Ltd.)  
24, Denmark Street  
London W.C.2  
Tel.: 01-836-3941

## GOOD MUSIC

Dumbarton House  
68, Oxford Street  
London W.1  
Tel.: 01-636-7906

## HEATHSIDE MUSIC

86, Marylebone High Street  
London W.1  
Tel.: 01-486-4353

## IMMEDIATE MUSIC LIMITED GETAWAY MUSIC LIMITED

(Avakak Songs Ltd.)  
(D'Abo Songs Ltd.)  
(James Page Music Ltd.)  
(Nice Songs & Lovely Music Ltd.)  
The Old House  
Petersham Road  
Richmond  
Surrey

## INTUNE LTD.

(Casanova Music Ltd.)  
13, Sunnyfield  
Mill Hill  
London N.W.7  
Tel.: 01-959-4499 & 01-959-7300

## ISLAND MUSIC LTD.

(B & C Music Ltd.)  
(Blue Mountain Music Ltd.)  
(Freshwater Music Ltd.)  
(Nootrac Music Ltd.)  
(Shawfield Music Ltd.)  
(Trees Music Ltd.)  
Remo House  
310/312, Regent Street  
London W.1  
Tel.: 01-636-7196

## DICK JAMES MUSIC LTD.

(A.I.R. (London) Music Ltd.)  
(Alto Music Ltd.)  
(Cookaway Music Ltd.)  
(Crystal Music Pub. Co. Ltd.)  
(Comet Music Limited)  
(D.J.M. (Distributors) Ltd.)  
(G.M. Music Ltd.)  
(Gralto Music Ltd.)  
(Gwyneth Music Ltd.)  
(Jaep Music Ltd.)  
(Jamil Music Ltd.)  
(Lords Music Co. Ltd.)  
(Maribus Music Ltd.)  
(Metro Music Ltd.)  
(Northern Songs Ltd.)  
(Nuova Music Ltd.)  
(Pacermusic Ltd.)  
(Santa Ponsa Music Ltd.)  
(Shair Music Ltd.)  
(Spencer Davis Music Ltd.)  
(This Record Co.)  
(Wonder Music Ltd.)  
(Lawrence Wright Music Co. Ltd.)  
James House  
71/75, New Oxford Street  
London W.C.1  
Tel.: 01-836-4864

## KASSNER ASSOCIATED PUBLISHERS LTD.

(A.J. Music Ltd.)  
(American Metro Music Ltd.)  
(Bens Music Ltd.)  
(Bonney Music Ltd.)  
(City Music Ltd.)  
(Coslow-Kassner Music Ltd.)  
(Cumberland Music Ltd.)  
(First Music Ltd.)  
(Grant Music Ltd.)

## KASSNER ASSOC. LTD (Con't)

(G.L.H. Music Ltd.)  
(Grosvenor Music Co. Ltd.)  
(Gale & Gayles Ltd.)  
(Edward Kassner Music Co. Ltd.)  
(Cecil Lennox Ltd.)  
(Myers Music Ltd.)  
(J. Norris Music Pub. Co. Ltd.)  
(Rush Music Ltd.)  
(Success Music Ltd.)  
(Schaeffers-Kassner Music Ltd.)  
(Unit Productions Ltd.)  
(Yukon Music Ltd.)  
Kassner House  
1, Westbourne Gardens  
Porchester Road  
London W.2  
Tel.: 01-229-3411

## K.M.P. MUSIC LTD.

(Ardmore & Beechwood Ltd.)  
(Associated British Music Ltd.)  
(Budd Music Ltd.)  
(Combine Music Ltd.)  
(Cooper Music Ltd.)  
(Elstree Music Ltd.)  
(Expansive Sound Productions Ltd.)  
(Forrest Hills Music Ltd.)  
(Gallico Music Ltd.)  
(Garrett Music Ltd.)  
(Imperia Music Co. Ltd.)  
(KPM Music Ltd.)  
(MacMelodies Ltd.)  
(Marlboro Music Ltd.)  
(Melita Music Ltd.)  
(Moss-Rose Music Ltd.)  
(Musicville Ltd.)  
(Raintree Music Ltd.)  
(Reynolds Music Ltd.)  
(Sam Fox Pub. Co. (London) Ltd.)  
(Television Music Co. Ltd.)  
(Villager Music Ltd.)  
(World Wide Music Co. Ltd.)  
(World Copyrights Ltd.)  
21, Denmark Street  
London W.C.2  
Tel.: 01-836-3856 & 5501

## LEEDS MUSIC LTD.

(Barton Music Ltd.)  
(Blossom Music Ltd.)  
(Challenge Music Ltd.)  
(Cricetk Music Ltd.)  
(Doheny Music Ltd.)  
(Duchess Music Ltd.)  
(Eugene Music Ltd.)  
(Holyhead Music Ltd.)  
(Janice Music Ltd.)  
(Jasper Music Ltd.)  
(Joy Music Ltd.)  
(Kags Music Ltd.)  
(Match Music Ltd.)  
(Melanie Music Ltd.)  
(Pickwick Music Ltd.)  
(Rawloul Music Ltd.)  
(Revue Music Ltd.)

## LEEDS MUSIC (Con't'd)

(Spoone Music Ltd.)  
(Tangerine Music Ltd.)  
(Threshold Music Ltd.)  
(Valley Music Ltd.)  
139 Picadilly  
London W.1  
Tel.: 01-629-7211

## LEMMEL MUSIC LTD.

Kings Court  
2/16, Goodge Street  
London WIP IFF  
Tel.: 01-580-9506

## LORNA MUSIC CO. LTD.

(Cinderella Music Ltd.)  
(Criterion/Lorna Music)  
(Charlie Parker Music Co. Ltd.)  
(Laurel Music Co. Ltd.)  
(Hooray Music Ltd.)  
(Mayhew Music Co. Ltd.)  
(Pattern Music Ltd.)  
(Norrie Paramor Music Ltd.)  
(Speedee Music Ltd.)  
(Woodside Music Ltd.)  
5, Denmark Street  
London W.C.2  
Tel.: 01-836-4741/2

## LYNN MUSIC

142 Charing Cross Road  
London W.C.2  
Tel.: 01-836-0827

## MARQUIS MUSIC CO. LTD.

(Marquis Enterprises Ltd.)  
(Misteltoe Melodies Ltd.)  
(Jonjo Music Co. Ltd.)  
(Verulam Music Co. Ltd.)  
37, Soho Square  
London W.1  
Tel.: 01-437-9405

## ROBERT MELLIN LTD. GROUP OF COMPANIES

(Admiration Music)  
(C.M.P. Music)  
(Franko London Music Ltd.)  
(Flying 'D' Music Ltd.)  
(Harriett Music)  
(Leeann Music)  
(Lloyd Logan Music Ltd.)  
(Olga Music)  
(Pancimel Music Ltd.)  
(Robert Mellin Productions)  
(Roxborough Music Ltd.)  
(Singular Music)  
(Schwartz Music)  
(Subar Music)  
(Top Note Music)  
24, Parkside  
Knightsbridge  
London S.W.1  
Tel.: 01-245-9026/7/8/9

## MEWS MUSIC LTD.

19/23, Wells Street  
London W.1  
Tel.: 01-580-2090

## MORGAN MUSIC CO. LTD.

169/171, High Road  
Willesden  
London N.W.10  
Tel.: 01-459-7244/7

(Con't. on Page 15)

**ARGENTINA**  
(Chile & Uruguay)

Disc Jockey

**AUSTRALIA**

E.M.I. (Australia) Ltd.

**BELGIUM (Luxembourg)**

Fonior S.A.

**BRAZIL**

Fermata Do Brasil Ltda.

**CANADA**

Trans World Record Co. Inc.

**GERMANY (Austria)**

Ariola Eurodisc GmbH

**GREECE**

Georgios Orphanidis

**HOLLAND**

Dureco N.V.

**ITALY**

Societa Italiana Fonografica spa

# MAJOR MINOR

## MAKE HIT RECORDS THAT GO ALL AROUND THE WORLD



Managing Director:  
**PHILIP SOLOMON**

Producers:  
**TOMMY SCOTT & DAVE BERNSTEIN**

58/59 Gt. Marlborough Street London W.1 01-437 5803

**JAPAN**

Toshiba Musical Industries Ltd.

**LEBANON**

Societe Libanaise due Disque

**MEXICO**

Mexicana de Discos Zave

**NEW ZEALAND**

His Masters Voice (NZ) Ltd.

**PORTUGAL**

Arnaldo Trindade & Co. Ltd.

**SINGAPORE**

E.M.I. South East Asia (Private) Ltd.

**SPAIN**

Discos Columbia S.A.

**S. AFRICA**

Gallo Africa (J'burg) Pty.

**SWITZERLAND**

Finsterwald & Cantacuzene

**ISRAEL**

Palestine Orient Co.



## ARE YOUR 'HITS' MISSING?

GET BACK ON TARGET WITH OUR WORLD-WIDE MUSIC PUBLISHING ORGANISATION

### ARDMORE & BEECHWOOD LTD.

CABLES: BEECHMORE LONDON WC2

### KEITH PROWSE MUSIC PUBLISHING CO. LTD.

### THE PETER MAURICE MUSIC COMPANY LTD.

CABLES: MAURITUNES LONDON WC2

21 DENMARK STREET, LONDON WC2H 8NE

Telephone: 01-836 5501 & 3856



**ARGENTINA**  
EDITORIAL MUSICAL ODEON  
BUENOS AIRES

**AUSTRALIA**  
CASTLE MUSIC PTY. LTD., SYDNEY

**BELGIUM**  
S.A. ARDMORE & BEECHWOOD  
(BELGIUM), BRUSSELS  
PETER MAURICE  
BELGOLUX S.A., BRUSSELS

**BRAZIL**  
SOCIEDADE BRASILEIRA DE  
EDICOES PUBLICIDADE SERVICOS  
ARTISTICOS LTDA, RIO DE JANEIRO

**DENMARK**  
IMUDICO A/S, COPENHAGEN

**FRANCE**  
LES EDITIONS ET PRODUCTIONS  
MUSICALES PATHE-MARCONI,  
PARIS

EDITIONS MUSICALES,  
PETER MAURICE, PARIS

**GERMANY**  
EDITION ACCORD, COLOGNE  
EDITION EXCELSIOR  
HANS GERIG, COLOGNE

**GREECE**  
ARION GREEK MUSIC COMPANY LTD.,  
ATHENS

**HOLLAND**  
ANAGON N.V., HEEMSTEDE

**HONG KONG**  
PATHE PUBLICATIONS  
(FAR EAST) LTD., KOWLOON

**ITALY**  
EDIZIONI MUSICALI LA VOCE  
DEL PADRONE, MILAN  
EDIZIONI MUSICALE  
PETER MAURICE, MILAN

**JAPAN**  
TOSHIBA MUSIC PUBLISHING CO.  
LTD., TOKYO

**MEXICO**  
BEECHWOOD DE MEXICO S.A.  
MEXICO CITY

**NEW ZEALAND**  
BELCAS MUSIC LTD., WELLINGTON

**SOUTH AFRICA**  
ARDMORE & BEECHWOOD  
(SOUTH AFRICA) (PTY.) LTD.  
JOHANNESBURG

**SPAIN**  
EGO MUSICAL S.A., BARCELONA

**SWEDEN**  
EDITION ODEON, STOCKHOLM

**U.S.A.**  
AL GALLICO MUSIC CORP.  
NEW YORK  
BEECHWOOD MUSIC CORP.  
HOLLYWOOD  
PETER MAURICE MUSIC CO. LTD.  
NEW YORK

**EMI**

Electric & Musical Industries Ltd., London, England

# GREAT BRITAIN'S MUSIC PUBLISHERS

(Con't from Page 16)

## MOTHER MISTRO MUSIC GROUP OF COMPANIES

Suite 201/206  
Albany House  
324, Regent Street  
London W.1  
Tel.: 01-580-1984

## MUSICUS LTD.

74, Newman Street  
London W.1  
Tel.: 01-580-0074

## NEMS PUBLISHING LTD.

Nemperor House  
Hill Street  
London W.1  
Tel.: 01-629-6341

## NOVELLO & CO. LTD.

(Elkin & Co. Ltd.)  
(Edward Arnold)  
Borough Green  
Seven Oaks  
Kent

Tel.: Borough Green 3261  
London Showroom:  
27, Soho Square  
London W.1  
Tel.: 437-122

## OMNIBUS MUSIC

3rd Floor, 12, Archer Street  
London W.1  
Tel.: 01-437-0980

## ORBIT UNIVERSAL MUSIC CO.

8, Albert Gate Court  
124, Knightsbridge  
London S.W.1  
Tel.: 01-589-6293

## OXFORD UNIVERSITY PRESS

44, Conduit Street  
London W1R 0DE  
Tel.: 01-734-5364

## PAGE INTERNATIONAL RECORDS LIMITED

4, Tilney Street  
Park Lane  
London W.1  
Tel.: 01-493-8873

## PAN-MUSIK LTD.

23, Denmark Street  
London W.C.2  
Tel.: 01-240-2816

## PEERS MUSIC LTD.

6, Denmark Place  
London W.C.2  
Tel.: 01-240-0891

## PLANETARY-NOM-LONDON LTD.

39/42, New Bond Street  
London W.1  
Tel.: 01-493-3074 & 4800

## G. RICORDI (LONDON) LTD.

The Bury  
Church Street  
Chesham,  
Bucks.  
Tel.: Chesham 3311 & 4427

## RINGMAKER MUSIC LTD.

(Nilsec Music)  
1, Harley Street,  
London W.1  
Tel.: 01-637-2531

## ROBBINS MUSIC CORPORATION LTD.

(Leo Feist Ltd.)  
35, Soho Square  
London W.1  
Tel.: 01-437-0068

## MR. SAM (MUSIC LIMITED)

169/171, High Road  
Willesden  
London N.W.10  
Tel.: 01-459-7244/7

## SCHAUER & MAY

Lyra House  
67, Belsize Lane  
Hampstead  
London N.W.3  
Tel.: 01-794-8038

## SHAFESBURY MUSIC CO. LTD.

37, Hertford Street  
London W.1  
Tel.: 01-499-2655

## SCHOTT & CO. LTD.

48, Great Marlborough Street  
London W.1V 2BN  
Tel.: 01-437-1246

## SCREEN GEMS-COLUMBIA MUSIC LTD.

(Colgems Music Corp.)  
St. Margarets House  
19/23, Wells Street  
London W.1  
Tel.: 01-580-2090

## A. SCHROEDER MUSIC PUBLISHING CO., LTD.

15, Berkeley Street  
London W.1X 5AE, England  
Tel.: 01-493-2506

Managing Director: Arthur Crisford

Anim, Annica, Arch, Avaris, Bella Godiva, Cat  
Mother, Dana-Don, Don Michael, Emm-Jay,  
Englewood, Fitness King, January, Joans Bones,  
Joint, Lar-Bell, Lassie, Manistee, Petone, Pitfield,  
Pitney, Promenade, Pooh, Sea-Lark, Stratton,  
Smith, Tijuca, Wrather, Yameta, Great Montana,  
Stewart-Nirms

## SHAPIRO BERNSTEIN & CO. LTD.

(Accolade Music Ltd.)  
(Aviva Music Ltd.)  
(Batt Songs Ltd.)  
(Blue Note Music Ltd.)  
(A.P.M. Music Ltd.)  
(Clare Music Ltd.)  
(Dekapa Music Ltd.)  
(Digger Dog Music Ltd.)  
(Glad Music Ltd.)  
(Mandrake Music Ltd.)  
(Nicolas Music Ltd.)  
(Skidmore Music Ltd.)  
(Twangy Music Ltd.)  
(Veronica Music Ltd.)

38, Soho Square  
London W.1  
Tel.: 01-437/3493/5

## CYRIL SHANE ORGANISATION

(Cyril Shane Music Ltd.)  
(Pedro Music Ltd.)  
(Gresham Music Ltd.)  
(Kipper Songs Ltd.)  
(Shanlot Music Ltd.)  
(Shanklin Music Ltd.)  
(Telescope Music Ltd.)  
(Tip Top Songs Ltd.)  
Univista Music Ltd.

Suite 22  
128/134, Baker Street  
London W.1  
Tel.: 01-486-4651/2

## SOUTHERN MUSIC PUBLISHING CO. LTD.

(Anglo Southern Film Music Pub. Co. Ltd.)  
(Bluebell Pub. Co. Ltd.)  
(Brio Music Pub. Co. Ltd.)  
(Carter Lewis Music Pub. Co. Ltd.)  
(Cedarwood Music Ltd.)  
(Donovan (Music) Ltd.)  
(Dunmo Music Pub. Co. Ltd.)  
(Iver Recording Co. Ltd.)  
(Latin American Music Pub. Co. Ltd.)  
(Liber Southern Ltd.)  
(Meridian Music Pub. Co. Ltd.)  
(Meteor Music Pub. Co. Ltd.)  
(Mirror Music Pub. Co. Ltd.)  
(Monique Music Ltd.)  
(Most Music Pub. Co. Ltd.)  
(Peer International Library Ltd.)  
(See Saw Music Ltd.)  
(South Eastern Music Pub. Co. Ltd.)  
(Southern Library of Recorded Music Ltd.)  
(Southern Monarch Film Music Pub. Co. Ltd.)  
(Southern Music Pub. Co. Ltd.)  
(Spark Records Ltd.)

8, Denmark Street  
London W.C.2  
Tel.: 01-836-4524

## SEGWAY MUSIC CO. LTD.

65, Lower Leeson Street  
Dublin 2  
Tel.: Dublin 63862

## 77 MUSIC

77, Charing Cross Road  
London W.C.2  
Tel.: 01-437-4197

## THE SPARTA FLORIDA MUSIC GROUP LIMITED

(Ember-Sparta Mood Music)  
(Hal Shaper Ltd.)  
(Halmusic Ltd.)  
(Noble Arts Film Music Ltd.)  
(Mike Berry Productions Ltd.)  
(RBM Music Ltd.)  
(Sleeping Bunny Music Ltd.)  
(Soul Music & Soul Records)  
(Sparta Music Ltd.)  
(Surefire Music & Surefire Records)  
(The Moody Blues)  
(Totem Pole Music)

155, 157 Oxford Street  
London W.1  
Tel.: 01-437-2468

## THE ROBERT STIGWOOD ORGANISATION LTD.

(Abigail Music (London) Ltd.)  
(Barnes Music Ltd.)  
(Brilliant Music Ltd.)  
(Bruce Music Ltd.)  
(P.E. Baker Music Ltd.)  
(Dratleaf Ltd.)  
(Mellow Yellow Music Ltd.)  
(Mont Grove Investments Ltd.)  
(R.S.O. Publishing Ltd.)  
(St. George Music Ltd.)  
(Marmalade Music Ltd.)  
(Throat Music Ltd.)  
(Venice Music Ltd.)  
(Winsak Music Ltd.)

67, Brook Street  
London W1Y 1YD  
Tel.: 01-629-9121

## SUNBURY MUSIC LTD.

(Aquarius Music Ltd.)  
(Buzz Music)  
(Casual Music Ltd.)  
(Clodagh Music Ltd.)  
(Groovy Music Ltd.)  
(Pennine Music Ltd.)  
(Sunshine Music Ltd.)

1, Derby Street  
London W.1  
Tel.: 01-493-9772

## THAMES MUSIC LTD.

39/41, New Bond Street  
London W.1Y 0JL  
Tel.: 01-499-5961

## UNITED ARTISTS MUSIC LTD.

(Cambridge Music Ltd.)  
(Dominion Music Co. Ltd.)  
(Grand Canyon Music Ltd.)  
(Galahad Music Ltd.)  
(Kama Sutra Music Ltd.)  
(Mapleak Music Ltd.)  
(Mortimer Music Ltd.)  
(Orbit Music Co. (Publishing) Ltd.)  
(Parnes Music Ltd.)  
(P.S. Music Ltd.)  
(Proud Productions Ltd.)  
(Rogers Music Ltd.)  
(Soho Music Ltd.)  
(Starfire Music Ltd.)  
(Sticks Music Ltd.)  
(Trio Music Co. Ltd.)  
(Zel Music Ltd.)

Mortimer House  
37/41, Mortimer Street  
London W.1  
Tel.: 01-636-1655

## UNITED MUSIC PUBLISHERS LTD.

1, Montague Street  
Russell Square  
London W.C.1 B 5BS  
Tel.: 01-636-5171

## UNCLE DORIS MUSIC LTD.

30, St. George Street  
Hanover Square  
London W.1  
Tel.: 01-499-9478

## UNIVERSAL EDITION (LONDON) LTD.

(Alfred A. Kalmus Ltd.)  
2/3, Fareham Street  
Dean Street  
London W.1V 4DU  
Tel.: 01-437-5203

## PETER WALSH MUSIC LTD.

(Avenue Artists Music Ltd.)  
(Dolphin Music Ltd.)  
(Fenwick Music Ltd.)  
(Gale Music Ltd.)  
(Rare Music Ltd.)  
(Tremeloes Music Ltd.)  
(Walrus Music Ltd.)

Wilmington Music Ltd.)  
6, Southampton Place  
London W.C.1  
Tel.: 01-405-0943

## WARNER MUSIC LTD.

69, New Oxford Street,  
London, W. C. 1.  
Tel.: 01-836-9381

## JOSEF WEINBERGER LTD.

(Glocken Verlag Ltd.)  
(Fred Benson Ltd.)  
(Background Music Pub. Co. Ltd.)  
(Inter-Art Music Publishers)  
(Oktava Music Co. Ltd.)  
(Programme Music Pub. Ltd.)

# Mews Music

19/23, WELLS STREET, LONDON, W. 1./TEL: 01-580-2090

# Martin - Coulter Enterprises

122, ST. GEORGES SQUARE MEWS, LONDON, S.W. 1./TEL: 01-828-3780

# Warner Bros. Music

*the largest music publisher in the world*

offices in. **NEW YORK** — George Lee, Vice-President, General Manager

**HOLLYWOOD** — Bill Sherman, General Manager

**LONDON** — Ian Ralfini, Managing Director

Tony Roberts, Professional Manager

with affiliation in:

ROME/TOKYO/MADRID/PARIS/MELBOURNE/MEXICO/JOHANNESBURG

BUENOS AIRES/GENEVA/COPENHAGEN/STOCKHOLM/AMSTERDAM/BERLIN.

# GREAT BRITAIN'S MILLION SELLERS

## PRE-1961 GOLD DISK AWARDS

Diana  
Let's Have A Party  
Petite Fleur  
Mary's Boy Child  
O Mein Papa  
Limelight  
What Do You Want To Make  
Those Eyes At Me For  
Rock Around The Clock  
We Will Make Love  
Harry Lime Theme  
He's Got The Whole World In His Hands  
Auf Wiedersehen  
Charmaine  
It's Now Or Never  
Living Doll  
Freight Train  
Cara Mia

Paul Anka  
Winifred Atwell  
Chris Barber  
Harry Belafonte  
Eddie Calvert  
Frank Chacksfield  
Emile Ford  
  
Bill Haley  
Russ Hamilton  
Anton Karas  
Laurie London  
Vera Lynn  
Montovani  
Elvis Presley  
Cliff Richard  
Nancy Whiskey  
David Whitfield

Columbia  
Philips  
Pye  
RCA  
Columbia  
Decca  
Pye

Brunswick  
Oriole  
Decca  
Parlophone  
Decca  
Decca  
RCA  
Columbia  
Oriole  
Decca

Do Wah Diddy Diddy  
Downtown  
Have I The Right  
I'll Never Find Another You  
I Feel Fine  
My Boy Lollipop  
You Really Got Me

Manfred Mann  
Petula Clark  
The Honeycombs  
The Seekers  
The Beatles  
Millie  
The Kinks

H.M.V.  
Pye  
Pye  
Columbia  
Parlophone  
Fontana  
Pye

## 1964-1965

## 1965-1966

## 1966-1967

## 1967-1968

## 1968-1969

## 1969-1970

## 1961-1962

## 1962-1963

## 1963-1964

Apache  
Are You Sure  
Does Your Chewing Gum Lose Its Flavor  
Midnight In Moscow  
Stranger On The Shore  
The Young Ones

The Shadows  
The Allison  
Lonnie Donegan  
Kenny Ball  
Acker Bilk  
Cliff Richard

Columbia  
Fontana  
Pye  
Pye  
Columbia  
Columbia

I Remember You  
Telstar  
Lovesick Blues

Frank Ifield  
The Tornados  
Frank Ifield

Columbia  
Decca  
Columbia

A World Without Love  
Bachelor Boy/The Next Time  
Bits & Pieces  
Can't Buy Me Love  
Diane  
Glad All Over  
I Want To Hold Your Hand  
Lucky Lips  
Lovesick Blues  
Little Children  
Needles And Pins  
She Loves You

Peter & Gordon  
Cliff Richard  
Dave Clark Five  
The Beatles  
The Bachelors  
Dave Clark Five  
The Beatles  
Cliff Richard  
Frank Ifield  
Billy J. Kramer  
The Searchers  
The Beatles

Columbia  
Columbia  
Columbia  
Parlophone  
Decca  
Columbia  
Parlophone  
Columbia  
Columbia  
Parlophone  
Pye  
Parlophone

A Groovy Kind Of Love  
Bend It

Green Green Grass Of Home  
Puppet On A String  
Release Me  
Send It On Home To Me  
Wild Thing  
Winchester Cathedral  
You Don't Have To Say You Love Me

The Mindbenders  
Dave, Dee, Dozy, Beaky,  
Mick and Tich  
Tom Jones  
Sandie Shaw  
Engelbert Humperdinck  
Spencer Davis  
The Troggs  
New Vaudeville Band  
Dusty Springfield

Fontana  
Fontana  
  
Decca  
Pye  
Decca  
Fontana  
Fontana  
Fontana  
Philips

Baby, Now That I've Found You  
Georgy Girl  
Lady Godiva  
Massachusetts  
Mighty Quinn  
Puppet On A String  
The Last Waltz  
Silence Is Golden

The Foundations  
The Seekers  
Peter and Gordon  
The Bee Gees  
Manfred Mann  
Sandie Shaw  
Engelbert Humperdinck  
The Tremeloes

Pye  
Columbia  
Parlophone  
Polydor  
Fontana  
Pye  
Decca  
CBS

Build Me Up Buttercup  
Ballad Of Bonnie & Clyde  
Congratulations  
Delilah  
It's Not Unusual

The Foundations  
Georgie Fame  
Cliff Richard  
Tom Jones  
Tom Jones

Pye  
CBS  
Columbia  
Decca  
Decca

Love Grows

Edison Lighthouse

Bell

L.P. awarded to The Beatles for million sales of their Parlophone L.P. "With The Beatles."

**CBS**

**STRAIGHT**

**BLUE HORIZON**

**DANDELION**

**DOLPHIN RECORDS**

**AURORA**

**THE LION'S SHARE OF THE TALENT**

**SALENA JONES**  
**JANIS JOPLIN**  
**SANTANA**  
**RAY STEVENS**  
**THE LOVE AFFAIR**  
**JOHNNY MATHIS**  
**CHRISTIE**  
**LAURA NYRO**  
**THE PEODLERS**  
**BLACK WIDOW**  
**U. C. SMITH**  
**TAJ MAHAL**  
**THE TREMELOES**

**SPiRiT**  
**TONY BENNETT**  
**THE BYROS**  
**JOHNNY CASH**  
**CHICAGO**  
**RAY CONNIFF**  
**MILES DAVIS**  
**BOB DYLAN**  
**FLOCK**  
**PERCY FAITH**  
**GEORGIE FAME**  
**TOM RUSH**  
**THE GUN**  
**TIM HARDIN**  
**ALAN HAVEN**

**GARY PUCKETT AND THE UNION GAP**  
**BLOOD SWEAT AND TEARS**  
**MAYNARD FERGUSON**  
**SIMON & GARFUNKEL**  
**THE CHAMBERS BROTHERS**  
**CUPID'S INSPIRATION**  
**THE RAIDERS**  
**SLY AND THE FAMILY STONE**  
**BARBRA STREISAND**  
**CHICKEN SHACK**  
**CHRISTINE PERFECT**  
**SOFT MACHINE**  
**MANITAS DE PLATA**  
**ANDY WILLIAMS**  
**JOHNNY WINTER**  
**LEONARD COHEN**  
**AL STEWART**

CBS Records 28/30 Theobalds Road London WC1



# ENGLAND: THE PAST 12 MONTHS

(Con't. from Page 9)

wood and Mike Hales as European and British representative respectively and Jan Olofsson resigned from the London helm of Olga Records to establish the Green Light Songs office. Philips launched its progressive Vertigo label, following in the track of EMI's Harvest line and the Moody Blues bowed their Threshold project via Decca. Pye and GRT heralded plans for a joint tape venture in the U.K. and the Beatles sold off a hefty slab of Northern Songs shares following their defeat at the hands of ATV for control of the pubbery. J.A. Freedman won the first Radio Luxembourg international song contest for Britain with "When You Walked Out of My

Life" and impresario Don Arden released details of his projected Aquarius enterprise involving disk production, label and artist management and publishing. Pye Records chief Louis Benjamin was named head of the Moss Empires Theatre chain in succession to the retiring Leslie Macdonnell, and retained his Pye duties.

NOVEMBER marked EMI's entry into the 8-track stereo cartridge field with a star-studded first release: Leslie Gould announced his departure from the London helm at Philips Records and John Robinson was named European marketing manager for MCA Records. ABC Records appointed John Snell as its European representative and Stuart Reid headed up a new pop division of Chappell Music with a brief to revitalise the publishing giant's activities in the pop field on an international scale. RCA fixed to handle Audio Fidelity product in the U.K. and Ireland and the Management Artists and Music group launched MAM Merchandising to cover goods being marketed with the name or endorsement of MAM stars Tom Jones and Englebert Humperdinck. Songwriter-producer Tony Macaulay signed five year pact with Bell Records and Stan West was named product manager for the European, African and Middle East divisions of Ampex Stereo Tapes. Bandleader Ted Heath died aged 67 after several years of declining health.

DECEMBER kicked off with the BBC giving details of its initial twelve new local radio stations, a number which would rise eventually to forty over the next four years, and IBC recording studios proclaimed its new label to be called UPC and headed by Eddie Tre-Vett. Radio North Sea International began its pirate transmissions off the Dutch coast and the Beatles reached final agreement on the sale of their Northern Songs stock to ATV while publisher Sean O'Mahony closed down the six-year old

Beatles Monthly magazine. A multi-million deal involving exchange of shares between Decca and Tom Jones and Englebert Humperdinck of MAM ensured their continued presence on Decca for another six years. Carlin Music and others took High Court action to stop pre-release importation of disks from the States with consequent alleged evasion of copyright royalty payments by the importers.

JANUARY 1970 began with the customary pre-Midem flurry of preparation and activity. Fred Marks of Festival Records in Australia was named as successor to Leslie Gould at the Philips helm in London and the Robert Stigwood Organisation ceased its plans for a reverse takeover of Arbitrator and Weston. Festival made its British bow with a single by Israeli movie star Dahliah Lavi and disk jockey Pete Murray collected the Order of the British Empire in the New Years Honours List. Warner Reprise outlined plans to present concerts by artists on its roster at major British venues as a promotional vehicle, and Reprise founder Frank Sinatra's May charity gigs in London were announced. The newly formed Country Music Association of Great Britain blueprinted plans for a larger slice of country music on the air and Leslie Gould was named chairman and managing director of Famous Chappell. Bob Kingston who heads up Southern Music in London visited Hollywood to record, in association with Denny Diante, an album with Eartha Kitt recently signed to the Peer Southern Organisation for release on the Spark label. A full crop of deals were set at the Midem meet in Cannes where EMI held a conference of its international publishing affiliates and branches to introduce the newly acquired Keith Prowse-Peter Maurice group to the family. Bob Kingston given further responsibilities within the Southern Music Organisation including closer liaison with branch offices resulting in extensive continental travel.

FEBRUARY brought a sudden executive move when John Fruin left his

merchandising director's chair at EMI to head Polydor in succession to Roland Rennie who took the helm of Polydor International. Lord Willis made an unsuccessful attempt to up the songwriters' royalty rate via a defeated bill in the House of Lords, and the budget Music for Pleasure label announced its entry in the language instruction market. CBS demonstrated its confidence in the future of underground music at its London Sales conference attended by international licencees. A & M Records headed here by Larry Yaskiel welcomed Sergio Mendes to Britain prior to their appearances in

(Con't. on Page 23)

## BRITISH LABEL AND SLEEVE MANUFACTURERS

THE E.J. DAY GROUP  
3, Olaf Street  
London W.11

GARROD & LOFTHOUSE LTD.  
5, Langley Street,  
London W.C.2

GRAPHIS PRESS LTD.  
1-3, Highbury Station Road  
London N.1

E. HANNIBAL & CO. LTD.  
Pinfold Street  
Thurmaston, Leicester

HARRISON & SONS LTD.  
Printing House Lane  
Hayes  
Middlesex

MacNEILL PRESS LTD.  
175, Bermondsey Street  
London S.E.1

ST. JAMES PRESS  
326, Kensal Road  
London W.10

UPTON PRINTING GROUP  
1, Doughty Street  
London W.C.1

WEST BROTHERS PRINTERS LTD.  
212 Durnford Road  
London S.W.19

## THE SYDNEY BRON

Group of Companies

LONDON

Publishing, Record Production, Artistes Management & Agency

Representing

GENE PITNEY

COLOSSEUM

JUICY LUICY

RICHARD BARNES

PETE BROWN &

PIBLOKTO!

URIAH HEEP

GENTLE GIANT

THE BLUE JEANS

29-31 Oxford Street, London, W.1.  
Tel: 01-437-5063/6  
Cables: Hitmusic London W. 1.

### LONDON

138-140, Charing Cross Road,  
London, W. C. 2.

### PARIS

Publications-Francis Day, S.A.  
5, Avenue de l'Opera

### AMSTERDAM

Francis-Day Muziekuitgevers N.V.  
Vossiusstraat 52

### HAMBURG

Francis Day & Hunter GMBH  
Mittelweg 149,  
2, Hamburg 13.

### ZURICH

Francis-Day Production  
Brunnwiesenstrasse 26

### MADRID

Canciones Francis-Day  
Carmen 20

### COPENHAGEN

Francis Day & Hunter  
Scandinavia A/S  
Gothersgade 9-11

## THE

## INTERNATIONAL PUBLISHERS

# FRANCIS DAY & HUNTER

# B. FELDMAN

# ROBBINS MUSIC

# DONNA MUSIC



### NEW YORK

Francis Day & Hunter Inc.  
745, Fifth Avenue

### BRUSSELS

Editions Francis-Day S.A.  
25, Place Saint-Gery

### MILAN

Edizioni Musicali  
Francis-Day S.R.L.  
Piazza Del Liberty 2

### JOHANNESBURG

Francis Day (S. Africa) Pty Ltd.  
Suite 901-4, 9th Floor  
Silvern House,  
139, Commissioner Street

### Agents

### AUSTRALIA

J. Albert & Son Pty Ltd.  
137-9, King Street,  
Sydney.

### JAPAN

Eastern Music Pub. Co. Ltd.  
Kyowa Building,  
34, Kotohira-cho,  
Shiba, Minato-ku,  
Tokyo.

**THE  
SPARTA FLORIDA  
MUSIC GROUP LIMITED**

**STILL  
BRITAIN'S NUMBER  
ONE INDEPENDENT  
MUSIC PUBLISHER!**

**REGGAE RUNAWAYS!**

**WE STARTED IT—  
OTHERS FOLLOWED!**

THE ISRAELITES: Desmond Dekker  
WET DREAM: Max Romeo  
MOON HOP: Derrick Morgan  
SWAN LAKE: The Cats  
CLINT EASTWOOD: The Upsetters  
TOO EXPERIENCED: Eddie Lovette  
SKINHEAD MOONSTOMP: Syramip  
and more!

**HOME HITS!**

Hit Tracks from

GLEN CAMPBELL  
MOODY BLUES

FAIRPORT CONVENTION  
FOUNDATIONS

BACK STREET BAND  
DAVID BOWIE

MARTIN CARTHY  
DESMOND DEKKER  
and more!

**MOVIE MUSIC!**

"Michael and Helga"

"Ned Kelly"

"Every Bastard is a King"

"Tam Lin"

in production:

"Mexico '70"

"Sweet and Sexy"

and more!

155/157 Oxford Street  
LONDON W.1. ENGLAND  
Telephone: 01 437 2468/9  
Cables: HALMUSIC LONDON

**CUSTOM PRESSING!  
CUSTOM PRESSING!**

FOR  
**KEENEST PRICES IN U.K.**

FOR  
**FASTEST DELIVERIES**

FOR  
**TOP QUALITY**

FOR

**DAILY DELIVERIES IN  
THE LONDON AREA**

**INDUSTRIAL  
COMMERCIAL  
PLASTICS, LTD.**

DEACON STREET LEICESTER  
LONDON OFFICE  
171, SHAFTESBURY AVENUE  
W.C. 2.  
Tel: 01-240-2661  
01-240-2750



GRAMOPHONE RECORDS  
LICENSING DEALS  
CUSTOM PRESSING  
CUSTOM RECORDINGS  
CO-PRODUCTIONS  
PRESSING MATERIAL  
BOOKS ON MUSIC  
MUSIC ENGRAVING

SOLE EXPORTERS

**ARTIA**

Foreign Trade Corporation

PRAHA 1, VE SMECKACH 30

CZECHOSLOVAKIA  
POB 790  
Telex ARTIA 11065  
Phone 246041



**ENGLAND'S BEST SELLING SHEET MUSIC**

Title	Publisher	
A Boy Named Sue	Essex	A
All I Have To Do is Dream	Acuff-Rose	A
All Kinds of Everything	Mews	A
Bridge Over Troubled Water	Pattern	A
Boom-Bang-A-Bang	Chappell	B
Ballad Of John And Yoko	Northern	B
Boxer	Pattern	A
Big Ship	E. H. Morris	B
Bad Moon Rising	Burlington	A
Come Back And Shake Me	April	B
Dizzy	Lowery	A
Don't Forget To Remember	Abigail	B
Early In The Morning	Leeds	B
Gentle On My Mind	Acuff-Rose	A
Goodbye	Carlin	F
Get Back	Northern	B
Goodnight Midnight	April	B
Good Morning Starshine	United Artists	A
Hello Susie	Essex	A
Honky Tonk Women	Mirage	B
In The Ghetto	Carlin	A
In The Year 2525	Essex	A
I'll Never Fall In Love Again	Blue Seas/Jac	A
Je T'aime Moi Non Plus	Shapiro Bernstein	F
Knock Knock Who's There	Monique	B
Living In The Past	Chrysalis	A
Love's Been Good To Me	Ambassador	A
Leaving On A Jet Plane	Harmony	A
Love Grows	Mustard/Schroeder/Mason	B
Monsieur Dupont	Carlin	F
Man Of The World	Immediate/Fleetwood	B
My Sentimental Friend	Monique	B
My Way	Shapiro Bernstein	F
Make Me An Island	Shaftesbury	B
My Cherie Amour	Jobete/Carlin	A
Melting Pot	Cookaway	B
Nobody's Child	Acuff-Rose	A
Ruby Don't Take Your Love To Town	Southern	A
Raindrops Keep Falling On My Head	Blue Seas/Jac	A
Something In The Air	Fabulous	B
Saved By The Bell	Saharet	B
Sugar Sugar	Weibeck	A
Two Little Boys	Darewski	A
Where Do You Go To My Lovely	Mortimer	B
Wanderin' Star	Chappell	A

A — American copyright B — British copyright F — Foreign copyright

**BRITISH TAPE MANUFACTURERS**

A.E.G. (GREAT BRITAIN) LTD.  
27, Chancery Lane,  
London W.C.2

AMPEX (GREAT BRITAIN) LTD.  
Acre Road,  
Reading, Berks.

BASF UNITED KINGDOM LTD.  
5a, Gillespie Road,  
London N.5

E.M.I. TAPE LTD.  
Blyth Road  
Hayes  
Middlesex

FERROGRAPH CO. LTD.  
84, Blackfriars Road  
London S.E.1

GEVASNOR LTD.  
Great West Road  
Brentford  
Middlesex

GRUNDIG (GREAT BRITAIN) LTD.  
Newlands Park,  
Sydenham, London S.E.26

KODAK LTD.  
Kodak House  
Kingsway  
London W.C.2

MASTERTAPE (MAGNETIC) LIMITED  
Prescot Road  
Poyle Trading Estate  
Colnbrook, Bucks.

MINNESOTA MINING & MFG. CO. LTD.  
3M House,  
Wigmore Street,  
London W.1

PHILIPS LTD.  
Century House  
Shaftesbury Avenue  
London S.W.1

R.C.A. (GREAT BRITAIN) LTD.  
Lincoln Way  
Windmill Road  
Sunbury, Middlesex.

TELEFUNKEN  
AEG (Great Britain) Ltd.  
27, Chancery Lane  
London W.C.2

**BRITISH PRESSING PLANTS**

ALLIED RECORDS LTD.  
326, Kensal Road,  
London W.10

BRITISH HOMOPHONE CO. LTD.  
Excelsior Works,  
Rollins Street,  
London S.E.15

CBS RECORDS LTD.  
(A Division of CBS U.K. Ltd.)  
Chamberlain Road,  
Aylesbury,  
Bucks.

THE DECCA RECORD CO. LTD.  
Albert Road  
New Malden  
Surrey

E.M.I. RECORDS  
(The Gramophone Co. Ltd.)  
Blyth Road  
Hayes  
Middlesex

INDUSTRIAL COMMERCIAL PLASTICS LIMITED  
Deacon Street  
Leicester

ORLAKE LTD.  
Sterling Works  
Rainham Road South  
Dagenham  
Essex

PHONODISC LTD.  
Record Works  
Walthamstow Avenue  
London E.4

SELCOL PRODUCTS LTD.  
Hall Street  
Long Melford  
Suffolk

TRANSCRIPTION & MANUFACTURING &  
RECORDING CO. LTD.  
James Estate  
Western Road  
Mitcham  
Surrey

# BRITISH ARTISTS TO BREAK INTO AMERICAN TOP 100 ALBUM CHARTS

Title	Artist	American Label	British Label
Are You Experienced?	Jimi Hendrix Experience	Reprise	Track
A Salty Dog	Procol Harum	A & M	Decca
A Step Further	Savoy Brown	Parrot	Decca
Abbey Road	The Beatles	Apple	Apple
Arthur	Kinks	Reprise	Pye
A Brand New Me	Dusty Springfield	Atlantic	Philips
Benefit	Jethro Tull	Reprise	Island
Best Of Traffic	Traffic	United Artists	Island
Blodwyn Pig	Blodwyn Pig	A & M	Island
Beck Ola	Jeff Beck Group	Epic	Columbia
Best Of The Bee Gees	The Bee Gees	Atco	Polydor
Best Of Cream	Cream	Atco	Polydor
Blind Faith	Blind Faith	Atco	Polydor
Beggar's Banquet	Rolling Stones	London	Decca
Build Me Up Buttercup	The Foundations	Uni	Pye
Colosseum	Colosseum	Dunhill	Vertigo
Cricklewood Green	Ten Years After	Deram	Deram
Donovan's Greatest Hits	Donovan	Epic	Pye
Engelbert Humperdinck	Engelbert Humperdinck	Parrot	Decca
Engelbert Humperdinck	Engelbert Humperdinck	Parrot	Decca
First Step	Small Faces	Warner Brothers	Warner Bros.
Fat Mattress	Fat Mattress	Atco	Polydor
Goodbye	Cream	Atco	Polydor
Green Green Grass Of Home	Tom Jones	Parrot	Decca
Hendrix Band Of Gypsies	Jimi Hendrix Experience	Capitol	Track
He Ain't Heavy, He's My Brother	Hollies	Epic	Parlophone
Help-Yourself	Tom Jones	Parrot	Decca
In The Court Of The Crimson King	King Crimson	Atlantic	Island
Joe Cocker	Joe Cocker	A & M	Regal Zonophone
Jethro Tull	Jethro Tull	Reprise	Island
Live Cream	Cream	Atco	Polydor
Live Peace in Toronto 1969	Plastic Ono Band	Apple	Apple
Looking Back	John Mayall	London	Decca
Led Zeppelin	Led Zeppelin	Atlantic	Atlantic
Led Zeppelin II	Led Zeppelin	Atlantic	Atlantic
Last Exit	Traffic	United Artists	Island
Let It Bleed	Rolling Stones	London	Decca
Mantovani Today	Mantovani	London	Decca
Odessa	Bee Gees	Atco	Polydor
On The Threshold Of A Dream	Moody Blues	Deram	Threshold
Postcard	Mary Hopkin	Apple	Apple
Portrait Of Petula	Petula Clark	Warner Brothers	Pye
Rare, Precious & Beautiful Vol. 2	Bee Gees	Atco	Polydor
Raw Sienna	Savoy Brown	Parrot	Decca
Smash Hits	Jimi Hendrix Experience	Reprise	Track
Street Noise	July Driscoll & Brian Auger	Atlantic	Marmalade
Shhhhh	Ten Years After	Deram	Deram
Songs For A Tailor	Jack Bruce	Atco	Polydor
Sgt. Pepper's Lonely Heart Club Band	The Beatles	Capitol	Parlophone
Stonehenge	Ten Years After	Deram	Deram
Stand Up	Jethro Tull	Reprise	Island
The Beatles	The Beatles	Apple	Apple
Tom Jones Live	Tom Jones	Parrot	Decca
The Mantovani Scene	Mantovani	London	Decca
To Our Children's Children's Children	Moody Blues	Threshold	Threshold
Two	Spooky Tooth	A & M	Island
Through The Past Darkly	Rolling Stones	London	Decca
The Turning Point	John Mayall	Polydor	Polydor
This Is Tom Jones	Tom Jones	Parrot	Decca
The World Of Mantovani	Mantovani	London	Decca
Tommy	The Who	Decca	Track
Tom Jones Live In Las Vegas	Tom Jones	Parrot	Decca
Ummagumma	Pink Floyd	Harvest	Columbia
Wheels Of Fire	Cream	Atco	Polydor
Yellow Submarine	The Beatles	Apple	Apple

## ENGLAND: Past 12 MOS.

(Con't. from Page 21)

the Grand Gala du Disques in Amsterdam. Mervyn Conn gave advance information about the second country music fest at Wembley in the Spring and Tito Burns left London Weekend Television to join the MAM organisation. Ron Randall was named European director for Hickory Records and Cliff Busby became EMI sales and distribution general manager following

John Fruin's departure. Plans to form a big band of young British musicians under the patronage of Count Alberto Cinzano were set forth and Ampex marketing administrator Fred Mandler said the company was contemplating establishing a duplication plant in the London area.

In FEBRUARY EMI dropped a bombshell by announcing price rises and abolition of the 5% allowance on returns; Pye closed its Birmingham distribution depot and struck off 1,700 dealers from its van call lists because they

(Con't. on Page 25)

The Greatest **INTERNATIONAL** Publishing Business



## IN EUROPE

**LONDON:** SOUTHERN MUSIC PUBLISHING CO. LTD. and associated companies  
8, Denmark Street.

**PARIS:** S.E.M.I.  
LES NOUVELLES EDITIONS  
MERIDIAN  
5 Rue Lincoln.

**HAMBURG:** PEER MUSIKVERLAG and associated companies  
Muehlenkamp 43.  
EDITION MARBOT  
Bornstrasse 12.

**MILAN:** EDIZIONI SOUTHERN MUSIC and associated companies  
Piazza Del Liberty 2.

**BARCELONA:** SOUTHERN MUSIC  
ESPANOLA  
Diputacion 337.

**MADRID:** MUSICA DEL SUR  
Hortaleza 18.

**STOCKHOLM:** SOUTHERN MUSIC A.B.  
Grev Turegatan 38.

**AMSTERDAM:** HOLLAND MUSIC  
Singel 500.

**BRUSSELS:** SOUTHERN MUSIC (BELGIUM) S.A.  
13 Rue de la Madeleine.

**VIENNA:** SOUTHERN MUSIC WIEN GmbH  
Seilergasse 12.

**SWITZERLAND:** SOUTHERN MUSIC A.G.  
Hausmelodie. 8604 Volketswil.

and all over the world.

## BEST SELLING ALBUMS FROM A&M

America	Herb Alpert & TJB	A&M
Beat of the Brass	Herb Alpert & TJB	A&M
Going Places	Herb Alpert & TJB	A&M
Introducing Sergio Mendes & Brasil '66	Sergio Mendes & Brasil '66	A&M
Warm	Herb Alpert & TJB	A&M

## BEST SELLING SINGLES FROM CBS

A Boy Named Sue	Johnny Cash	CBS
Bringing on back the good Times	Love Affair	CBS
Baby Make it Soon	Marmalade	CBS
Birth	Peddlers	CBS
Bridge Over Troubled Waters	Simon & Garfunkel	CBS
By the Way	Tremeloes	CBS
Call Me Number One	Tremeloes	CBS
Can't Help falling in Love	Andy Williams	CBS
Everything is Beautiful	Ray Stevens	CBS
Groovy Baby	Microbe	CBS
Good Morning Starshine	Oliver	CBS
Girlie	Peddlers	CBS
Happy Heart	Andy Williams	CBS
I'm a Man	Chicago	CBS
I'd Rather go Blind	Chicken Shack	CBS
Lay Lady Lay	Bob Dylan	CBS
Need your Love so Bad	Fleetwood Mac	CBS
Peaceful	Georgie Fame	CBS
Seventh Son	Georgie Fame	CBS
The Boxer	Simon & Garfunkel	CBS
Tears in the Wind	Chicken Shack	CBS
What is Truth	Johnny Cash	CBS
You've made me so very Happy	Blood, Sweat & Tears	CBS
Yellow River	Christie	CBS

## BEST SELLING ALBUMS FROM CBS

At San Quentin	Johnny Cash	CBS
At Folsom Prison	Johnny Cash	CBS
Andy Williams Greatest Hits	Andy Williams	CBS
Bookends	Simon & Garfunkel	CBS
Best of the Marmalade	Marmalade	CBS
Bob Dylan's Greatest Hits	Bob Dylan	CBS
Blood, Sweat & Tears	Blood, Sweat & Tears	CBS
Chicago Transit Authority	Chicago	CBS
Chicago	Chicago	CBS
Funny Girl	Original Soundtrack	CBS
Fiddler on the Roof	Original London Cast	CBS
Fill Your Head with Rock	Various Artists	CBS
Gunfighter Ballads	Marty Robbins	CBS
Get Together with Andy Williams	Andy Williams	CBS
Hello, I'm Johnny Cash	Johnny Cash	CBS
His Orchestra, His Chorus, His Singers, His Sound	Ray Conniff	CBS
Happy Heart	Andy Williams	CBS
Johnny Cash's Greatest Hits	Johnny Cash	CBS
My Fair Lady	Original Soundtrack	CBS
Nashville Skyline	Bob Dylan	CBS
Parsley, Sage, Rosemary & Thyme	Simon & Garfunkel	CBS
Rock Machine—I Love You	Various Artists	CBS
Songs of Leonard Cohen	Leonard Cohen	CBS
Songs from a Room	Leonard Cohen	CBS
Sounds of Silence	Simon & Garfunkel	CBS
Tony Bennett's Greatest Hits	Tony Bennett	CBS
The Graduate	Simon & Garfunkel	CBS
West Side Story	Original Soundtrack	CBS
Wednesday Morning 3 a.m.	Simon & Garfunkel	CBS

## BEST SELLING SINGLES FROM DECCA

All Kinds of Everything	Dana	Rex
Daughter of Darkness	Tom Jones	Decca
Friend	The Arrival	Decca
Honky Tonk Women	The Rolling Stones	Decca
I'm a Better Man	Engelbert Humperdinck	Decca
Love Me Tonight	Tom Jones	Decca
Let It All Hang Out	Jonathan King	Decca
My Baby Loves Love	White Plains	Deram
Question	The Moody Blues	Threshold
Reflections of My Life	The Marmalade	Decca
Sally	Gerry Monroe	Chapter One
Tracy	Cuff Links	MCA
The Holy City	Moir Anderson	Decca
United We Stand	The Brotherhood of Man	Deram
Winter World of Love	Engelbert Humperdinck	Decca
Without Love	Tom Jones	Decca
When Julie Comes Around	Cuff Links	MCA

## BEST SELLING ALBUMS FROM DECCA

A Man Without Love	Engelbert Humperdinck	Decca
Buddy Holly's Greatest Hits	Buddy Holly	Coral
Beggar's Banquet	The Rolling Stones	Decca
Cricklewood Green	Ten Years After	Deram
Engelbert Humperdinck	Engelbert Humperdinck	Decca
High Tide Green Grass	The Rolling Stones	Decca

## BEST SELLING ALBUMS FROM DECCA (Con't.)

Let it Bleed	The Rolling Stones	Decca
Looking Back	John Mayall	Decca
Mantovani Today	Mantovani	Deram
On the Threshold of a Dream	The Moody Blues	Decca
Raw Sienna	Savoy Brown	Deram
Shhhh	Ten Years After	Deram
Snafu	East of Eden	Decca
This is Tom Jones	Tom Jones	Decca
Through the Past Darkly	The Rolling Stones	Decca
To Our Children's Children's Children	The Moody Blues	Threshold
The World of John Mayall	John Mayall	Decca
Tom	Tom Jones	Decca
The World of Mantovani Vol. 1	Mantovani	Decca
The World of the Bachelors Vol. 1	Bachelors	Decca
Tom Jones Live in Las Vegas	Tom Jones	Decca
The World of Reginald Dixon	Reginald Dixon	Decca
World of Val Doonican	Val Doonican	Decca
World of Mantovani Vol. 2	Mantovani	Decca
World of Hits Vol. 1	Various Artists	Decca
World of Val Doonican Vol. 2	Val Doonican	Decca
World of the Bachelors Vol. 2	Bachelors	Decca
World of Hits Vol. 2	Various Artists	Decca
World of Brass Bands	Various Artists	Decca
World of Oliver	Various Artists	Decca
World of Charlie Kunz	Charlie Kunz	Decca
World of Progressive Music	Various Artists	Decca
World of Kenneth McKellar	Kenneth McKellar	Decca
World of Phase 4 Stereo	Various Artists	Decca
World of Blues Power	Various Artists	Decca

## BEST SELLING SINGLES FROM E.M.I.

All I Have to do is Dream	Bobbie Gentry & Glen Campbell	Capitol
Breakaway	Beach Boys	Capitol
Ballad of John & Yoko	The Beatles	Apple
Born to be Wild	Steppenwolf	Stateside
Be Young, Be Foolish, Be Happy	The Tams	Stateside
Boom Bang-A-Bang	Lulu	Columbia
Behind a Painted Smile	Isley Brothers	Tamla Motown
Big Ship	Cliff Richard	Columbia
Conversations	Cilla Black	Parlophone
Curly	The Move	Regal Zonophone
Cloud Nine	Temptations	Tamla Motown
Cold Turkey	Plastic Ono Band	Apple
Dizzy	Tommy Roe	Stateside
Do What You Gotta Do	Four Tops	Tamla Motown
Delta Lady	Joe Cocker	Regal Zonophone
Dick-A-Dum-Dum	Des O'Connor	Columbia
Everybody Get Together	Dave Clark Five	Columbia
Farewell is a Lonely Sound	Jimmy Ruffin	Tamla Motown
Give Peace a Chance	Plastic Ono Band	Apple
Get Back	The Beatles	Apple
Good Old Rock 'n' Roll	Dave Clark Five	Columbia
Gin Gan Goolie	The Scaffold	Parlophone
Gimme Dat Ding	Pipkins	Columbia
Games People Play	Joe South	Capitol
Get Ready	Temptations	Tamla Motown
Good Times	Cliff Richard	Columbia
He Ain't Heavy, He's My Brother	The Hollies	Parlophone
It's Getting Better	Mama Cass	Stateside
I've Passed This Way Before	Jimmy Ruffin	Tamla Motown
I'll Never Fall in Love Again	Bobbie Gentry	Capitol
I Second That Emotion	Diana Ross & Supremes & Temptations	Tamla Motown
I Miss You Baby	Marv Johnson	Tamla Motown
I Can't Get Next to you	Temptations	Tamla Motown
I Want You Back	Jackson 5	Tamla Motown
Instant Karma	Plastic Ono Band	Apple
I Can't Help Myself	Four Tops	Tamla Motown
I Heard it through the Grapevine	Marvin Gaye	Tamla Motown
I Can Hear Music	Beach Boys	Capitol
I Don't Know Why	Stevie Wonder	Tamla Motown
I'm Livin' in Shame	Diana Ross & Supremes	Tamla Motown
Joy of Living	Cliff & Hank	Columbia
Love at first Sight	Sounds Nice	Parlophone
Leavin' (Durham Town)	Roger Whittaker	Columbia
Loneliness	Des O'Connor	Columbia
Love Grow	Edison Lighthouse	Bell
Let it Be	Beatles	Apple
My Cherie Amour	Stevie Wonder	Tamla Motown
My Sentimental Friend	Herman's Hermits	Columbia
Never Had a Dream Come True	Stevie Wonder	Tamla Motown
Put Yourself in my Place	Isley Brothers	Tamla Motown
Put a little Love in your Heart	Dave Clark Five	Columbia
Please Don't Go	Donald Peers	Columbia
Raindrops Keep Falling on my Head	Bobbie Gentry	Capitol
Road Runner	Jr. Walker & All Stars	Tamla Motown
Soul Deep	Box Tops	Bell
Soul Clap '69'	Booker T & the MG's	Stax
Something	Beatles	Apple
Someday We'll Be Together	Diana Ross & The Supremes	Tamla Motown
Sorry Suzanne	The Hollies	Parlophone
Surround Yourself with Sorrow	Cilla Black	Parlophone
Too Busy Thinking about my Baby	Marvin Gaye	Tamla Motown
Tears Won't Wash away my Heartaches	Ken Dodd	Columbia
Time is Tight	Booker T & The MG's	Stax
Throw Down a Line	Cliff & Hank	Columbia
25 Miles	Edwin Starr	Tamla Motown
Two Little Boys	Rolf Harris	Columbia
Try a little Kindness	Glen Campbell	Capitol
Tracks of my Tears	Smokey Robinson & Miracles	Tamla Motown
Way of Life	Family Dog	Bell
What Does it take	Jr. Walker & All Stars	Tamla Motown
With the Eyes of a Child	Cliff Richard	Columbia
Wanderin' Star	Lee Marvin	Paramount
Why (Must we fall in Love)	Diana Ross & Supremes & Temptations	Tamla Motown
What is a Man	Four Tops	Tamla Motown
Yester-me, Yester-you, Yesterday	Stevie Wonder	Tamla Motown
Years May Come, Years May Go	Herman's Hermits	Columbia

## BEST SELLING LP'S FROM E. M. I.

Abbey Road	The Beatles	Apple
Best of Cilla Black	Cilla Black	Parlophone
Best of the Beach Boys	Beach Boys	Capitol
Best of Gene Pitney	Gene Pitney	Stateside
Blue Hawaii	Wout Steenhuis	Regal Starline
Best of Beach Boys Vol. 1	Beach Boys	Capitol
Bobbie Gentry & Glen Campbell	Bobbie Gentry & Glen Campbell	Capitol
Best of Nat King Cole	Nat King Cole	Capitol
Beard of Stars	Tyrannosaurus Rex	Regal Zonophone
Bug-In	Beach Boys	Regal Starline
Cosa Nostra—Beck Ola	Jeff Beck	Columbia
Cloud Nine	Temptations	Tamla Motown
Cream of the Crop	Diana Ross & Supremes	Tamla Motown
Collection of big Hits Vol. 8	Various	Tamla Motown
Capitol's Country Festival	Various	Regal Starline
Diana Ross & The Supremes join the Temptations	Diana Ross & The Supremes join The Temptations	Tamla Motown
Deep Purple in Concert with the Royal Philharmonic Orch.	Deep Purple in Concert with the Royal Philharmonic Orch.	Harvest
Diana Ross Presents The Jackson 5	Jackson 5	Tamla Motown
Easy Rider	Music From the Film	Stateside
Frank Sinatra sings the select Cole Porter	Frank Sinatra	Regal Starline
Fully Qualified Survivor	Michael Chapman	Harvest
Greatest Hits	Four Tops	Tamla Motown
Glen Campbell 'Live'	Glen Campbell	Capitol
Golden Hits	Shirley Bassey	Columbia
Hollies Sing Dylan	Hollies	Parlophone
Hank Marvin	Hank Marvin	Columbia
Hello Dolly	Soundtrack	Stateside
Impact	Various Artists	Studio Two
It'll be me	Cliff Richard	Regal Starline

# CARLIN MUSIC CORPORATION

Britain's Top Publisher

(As Voted by The Record Retailer for 1966-67; 1967-68; 1968-69; 1969-70)

General Professional Manager: PAUL RICH

17, SAVILE ROW, LONDON, W1X 1AE



## BEST SELLING SINGLES FROM MAJOR MINOR

Allentown Jail	Karen Young	Major Minor
Busybody	Neville Dickie	Major Minor
Cupid	Johnny Nash	Major Minor
Dream of Olwyn	Second City Sound	Major Minor
Everybody Knows	Miki & Griff	Major Minor
Erotica	Rita	Major Minor
Gimme Gimme Good Lovin'	Crazy Elephant	Major Minor
Hey Ya	Jeronimo	Major Minor
It's Your Thing	The Isley Brothers	Major Minor
Je T'aime moi non Plus	Jane Birkin/Serge Gainsbourg	Major Minor
Love is All	Malcolm Roberts	Major Minor
Lords Prayer	Ray Morgan	Major Minor
My Elusive Dreams	Jon Hamilton/Karen Young	Major Minor
Nobody's Child	Karen Young	Major Minor
On the Run	Custer's Track	Major Minor
Please Don't Go Away	Malcolm Roberts	Major Minor
Que Sera Sera	Karen Young	Major Minor
Robin's Return	Neville Dickie	Major Minor
Sunshine Red Wine	Crazy Elephant	Major Minor
The Deal	Pat Campbell	Major Minor
Today I Killed a Man I Didn't Know	Jon Hamilton	Major Minor
Two Little Orphans	Miki & Griff	Major Minor
We Can Make it Girl	Malcolm Roberts	Major Minor

## BEST SELLING LP'S FROM MAJOR MINOR

Aznavour Sings Aznavour	Charles Aznavour	Major Minor
All Time Party	The Dubliners	Major Minor
A Drop of the Dubliners	Ronnie Hawkins	Major Minor
Arkansas Rock Pile	Various Artists	Major Minor
Beat Party	Count Basie	Major Minor
Bumper Bundle of Hits	Crazy Elephant	Major Minor
Barrack Room Ballads	Various Artists	Major Minor
Best of Basie Vols. 1 & 2	Count Basie	Major Minor
Crazy Elephant	Crazy Elephant	Major Minor
Children's Songs	Isley Brothers	Major Minor
Cocktail Time	Neville Dickie	Major Minor
Hawaiian Party	Neville Dickie	Major Minor
It's Our Thing	Pat Campbell	Major Minor
Introducing Neville Dickie	Kim Weston & Johnny Nash	Major Minor
I Love a Piano	Malcolm Roberts	Major Minor
Just a quiet Conversation	Karen Young	Major Minor
Kim Weston & Johnny Nash	Johnny Nash	Major Minor
Malcolm	Raymond Lefevre	Major Minor
Nobody's Child	Miki & Griff	Major Minor
Piano Party	Count Basie	Major Minor
Rugby Songs Party	Count Basie	Major Minor
Soul Folk	Count Basie	Major Minor
Strauss Waltzes	Johnny Nash	Major Minor
Those Rocking Chair People	Raymond Lefevre	Major Minor
The Atomic Mr. Basie	Miki & Griff	Major Minor
The Chairman of the Board	Count Basie	Major Minor

## BEST SELLING SINGLES FROM PHILIPS

Am I the Same Girl	Dusty Springfield	Philips
Brand New Me	Dusty Springfield	Philips
Boogaloo Party	Flamingos	Philips
Don Juan	Dave Dee, Dozy, Beaky, Mick & Tich	Fontana
Good Morning Freedom	Blue Mink	Philips
Je T'aime Moi Non Plus	Jane Birkin & Serge Gainsborough	Fontana
Lights of Cincinnati	Scott Walker	Philips
Little Green Apples	Roger Miller	Mercury
Melting Pot	Blue Mink	Philips
My Woman's Man	Dave Dee	Fontana
Na Na Hey Hey Kiss Him Goodbye	Steam	Fontana
Passing Strangers	Sarah Vaughan & Billy Eckstine	Mercury
Ragamuffin Man	Manfred Mann	Fontana
Sanctus	Troubadours du Roi Baudouin	Philips
Space Oddity	David Bowie	Philips
Snake in the Grass	Dave Dee, Dozy, Beaky, Mick & Tich	Fontana
Who Do You Love	Juicy Lucy	Vertigo

## BEST SELLING LP'S FROM PHILIPS

At your Request	Harry Secombe	Philips
An Old Raincoat Won't Ever Let you down	Rod Stewart	Vertigo
Ark	Flaming Youth	Fontana
Black Sabbath	Black Sabbath	Vertigo
Exquisite Nana Mouskouri	Nana Mouskouri	Fontana
Favourite Song of Richard Tauber	Harry Secombe	Philips
Joan Baez on Vanguard	Joan Baez	Vanguard
Juicy Lucy	Juicy Lucy	Vertigo
Ofarim Concert Live '69	Esther & Abi Ofarim	Philips
Over & Over	Nana Mouskouri	Fontana
Rock & Roll	Chuck Berry, Jerry Lee Lewis, Fats Domino	Fontana Special
Scott 3	Scott Walker	Philips
Scottish Love Songs	Corries	Fontana
Seekers Golden Collection	Seekers	Fontana Special
Songs from his T.V. Series	Scott Walker	Philips
Valentyne Suite	Colosseum	Vertigo

## BEST SELLING SINGLES FROM POLYDOR

August October	Robin Gibb	Polydor
Both Sides Now	Judy Collins	Elektra
Comin' Home	Delaney & Bonnie	Atlantic
Don't Forget to Remember	Bee Gees	Polydor
Don't Waste My Time	John Mayall	Polydor
Desdemona	Marsha Hunt	Track
Hey Joe	Wilson Pickett	Atlantic
I'm Gonna Make You Mine	Lou Christie	Buddah
I.O.I.O.	Bee Gees	Polydor
Keep the Customer Satisfied	Marsha Hunt	Track
Love Man	Otis Redding	Atco
Marrakesh Express	Crosby, Stills, Nash & Young	Atlantic
Oh Happy Day	Edwin Hawkins Singers	Buddah
Oh Me Oh My	Lulu	Atco
Something in the Air	Thunderclap Newman	Track
Saved by the Bell	Robin Gibb	Polydor
She Sold me Magic	Lou Christie	Buddah
Tomorrow, Tomorrow	Bee Gees	Polydor
The Seeker	Who	Track

## BEST SELLING LP'S FROM POLYDOR

Aretha's Gold	Aretha Franklin	Atlantic
Blind Faith	Blind Faith	Polydor
Best of the Bee Gees	Bee Gees	Polydor
Best of the Cream	Cream	Polydor
Crosby, Stills, Nash & Young	Crosby, Stills, Nash & Young	Atlantic
Dock of the Bay	Otis Redding	Atco
Fat Mattress	Fat Mattress	Polydor
Goodbye Cream	Cream	Polydor
History of Otis Redding	Otis Redding	Atco
Hammond A Go Go	James Last	Polydor
Jack Bruce	Jack Bruce	Polydor
Led Zeppelin	Led Zeppelin	Atlantic
Led Zeppelin II	Led Zeppelin	Atlantic
Live at the Apollo 2 Vols.	James Brown	Polydor
Love Four Sail	Love	Elektra
My Favourite Instrument	Oxcar Petersen	Polydor
Non Stop Dancing '69	James Last	Polydor
Odessa	Bee Gees	Polydor
Oh Happy Day	Edwin Hawkins Singers	Buddah
Otis Redding in Europe	Otis Redding	Atco
Soul 69	Aretha Franklin	Atlantic
Streetnoise	Julie Driscoll, Brian Auger & the Trinity	Marmelade
Trumpet A Go Go Vols. I, II, III	James Last	Polydor
Tommy	Who	Track
The Original Delaney & Bonnie	Delaney & Bonnie	Elektra
The Soft Parade	Doors	Elektra
The Turning Point	John Mayall	Polydor

## BEST SELLING SINGLES FROM PYE

Are you growing tired of my Love	Status Quo	Pye
Barabajagal	Donovan & Jeff Beck Group	Pye
Born to live, born to die	The Foundations	Pye
Baby take me in your Arms	Jefferson	Pye
Cry Baby Cry	Ramsey Lewis	Carnaby
Color him Father	The Winstons	Pye
Drivin'	The Kinks	Pye
Don't cry my Angelina	Val Doonican	Pye
Happy Heart	Petula Clark	Pye
"Jean" (from the film "The Prime of Miss Jean Brodie")	The Alexander Brothers	Pye
Love of a Gentle Woman	Val Doonican	Pye
Make me an Island	Joe Dolan	Pye
My Little Chickadee	Geno Washington & The Ram Jam Band	Pye
Many The Memories	Real McCoy	Pye
Pretty Belinda	Chris Andrews	Pye
People Got to be Free	Dionne Warwick	Pye
Rescue Me	Fontella Bass	Carnaby
Sing a Rainbow, Love is Blue	The Dells	Carnaby
Shangri-La	The Kinks	Pye
That Same Old Feeling	Pickettywitch	Pye
Teresa	Joe Dolan	Pye
The Straight Life	Val Doonican	Pye
Victoria	The Kinks	Pye
Who Do You Think you are Mr. Hitler?	Bud Flanagan	Pye
You're a good looking Woman	Joe Dolan	Pye

## BEST SELLING LP'S FROM PYE

A Little Bitty Tear	Miki & Griff	Marble Arch
Autumn Chartbusters	Various Artists	Marble Arch
Arthur, or The Decline & Fall of the British Empire	The Kinks	Pye
Chartbusters—Movin'	Various Artists	Marble Arch
Chartbusters Now	Various Artists	Marble Arch
Chartbusters '70	Various Artists	Marble Arch
Chartbusters Booming	Various Artists	Marble Arch
Greatest Country & Western Hits	Various Artists	Marble Arch
Hair	The Aquarius	Marble Arch
Joe Dolan's Greatest Hits	Joe Dolan	Marble Arch
Just Pet	Petula Clark	Pye
Late Night Listening in Stereo	Various Artists	Pye
Max Bygraves	Max Bygraves	Marble Arch
Mr. & Mrs. Music	Jackie Trent & Tony Hatch	Pye
Nina Simone at Newport	Nina Simone	Marble Arch
Showcase (A Marble Arch Sampler)	Various Artists	Marble Arch
Sounds Gentle	Val Doonican	Pye
Soul Spectacular	Various Artists	Marble Arch
Stars of '69	Various Artists	Marble Arch
Stan Reynolds plays a Stereo Salute to James Last	Stan Reynolds & his Orchestra	Marble Arch
Spring Chartbusters	Various Artists	Marble Arch
Stan Reynolds plays a Stereo Salute to James Last Vol. 2	Stan Reynolds & his Orchestra	Marble Arch
Stereo Spectacular	Various Artists	Marble Arch
Soulful	Dionne Warwick	Pye
Songs from Mary Poppins	Various Artists	Marble Arch
The World of Donovan	Donovan	Marble Arch
The Foundations	The Foundations	Marble Arch
Top Chartbusters of '69	Various Artists	Marble Arch
Tribute to Johnny Cash	Johnny Cash	Marble Arch
The Sandie Shaw Supplement	Sandie Shaw	Marble Arch
The Hitmakers	Various Artists	Marble Arch
The Bacharach & David Song Book	Sheila Southern	Marble Arch
Uptight	Geno Washington & the Ram Jam Band	Marble Arch
Walt Disney presents songs from The Jungle & other Jungle Favourites	The Jungle V.I.P.s	Marble Arch

## BEST SELLING SINGLES FROM RCA

American Woman	Guess Who	RCA
And The Sun Will Shine	Jose Feliciano	RCA
Bijou	Clodagh Rodgers	RCA
But You Love Me Daddy	Jim Reeves	RCA
Clean Up Your Own Backyard	Elvis Presley	RCA
Cecilia	Harmony Grass	RCA
Don't Cry Daddy	Elvis Presley	RCA
Don't You Know (She Said Hello)	Butterscotch	RCA
Everybody's Talkin'	Nilsson	RCA
Goodnight Midnight	Clodagh Rodgers	RCA
In The Ghetto	Elvis Presley	RCA
In the Year 2525	Zager & Evans	RCA
Jingle Jangle	The Archies	RCA
Kentucky Rain	Elvis Presley	RCA
Move In a Little Closer	Harmony Grass	RCA
Nobody's Fool	Jim Reeves	RCA
Ole Turkey Buzzard	Jose Feliciano	RCA
Suspicious Minds	Elvis Presley	RCA
Sugar Sugar	The Archies	RCA
When Two Worlds Collide	Jim Reeves	RCA

## BEST SELLING ALBUMS FROM RCA

According to My Heart	Jose Feliciano	RCA
Ain't Misbehavin'	Fats Waller	RCA
Bless It's Little Pointed Head	Jefferson Airplane	RCA
Feliciano	Jose Feliciano	RCA
Flaming Star	Elvis Presley	RCA
Glen Miller Story	Glen Miller	RCA
Glen Miller Memorial	Glen Miller	RCA
Hair	Broadway Cast	RCA
Jeanette McDonald/Nelson Eddy	Jeanette McDonald	RCA
Jim Reeves Golden Records	Jim Reeves	RCA
Jim Reeves On Stage	Jim Reeves	RCA
Jim Reeves and Friends	Jim Reeves	RCA
Let's Be Friends	Elvis Presley	RCA
Memphis to Vegas	Elvis Presley	RCA
Oliver	Soundtrack	RCA
Sound of Music	Soundtrack	RCA
Twanging the Golden Hits	Duane Eddy	RCA
TV Spectacular	Elvis Presley	RCA
The Nearness of You	Glen Miller	RCA
Volunteers	Jefferson Airplane	RCA

## BEST SELLING SINGLES FROM WARNER BROS.

Love's Been Good to me	Frank Sinatra	Reprise
Leaving on a Jet Plane	Peter, Paul & Mary	Warner Bros.
My Way	Frank Sinatra	Reprise
No Mule's Fool	Family	Reprise
Oh Well	Fleetwood Mac	Reprise
Ruby, Don't Take Your Love to Town	Kenny Rogers & The First Edition	Reprise
Raindrops Keep Falling on my Head	Sacha Distel	Warner Bros.
Something's Burning	Kenny Rogers & The First Edition	Reprise
Spirit in the Sky	Norman Greenbaum	Reprise
The Highway Song	Nancy Sinatra	Reprise

## BEST SELLING LP'S FROM WARNER BROS.

A Song for me	Family	Reprise
Alice's Restaurant	Arl Guthrie	Reprise
Burnt Weeny Sandwich	Mothers of Invention	Bazaar
Hot Rats	Frank Zappa	Reprise
Sacha Distel	Sacha Distel	Warner Bros.
Then Play On	Fleetwood Mac	Reprise
Watertown	Frank Sinatra	Reprise

# ATLANTIC RECORDS AROUND THE WORLD



*Atlantic Records are released on the Atlantic Label in the following countries...*

**ARGENTINA:**  
PHONOGRAM, S.A.I.C.

**AUSTRALIA:**  
FESTIVAL RECORDS PTY. LTD.

**AUSTRIA:**  
AMEDEO-OSTERREICHISCHE  
SCHALLPLATTEN A.G.

**BELGIUM:**  
COMPAGNIE PHONOGRAPHIQUE  
FRANCO-BELGE BARCLAY

**BRAZIL:**  
COMPANHIA BRASILEIRA DE DISCOS

**CANADA:**  
WARNER BROS. /  
SEVEN ARTS RECORDS, LTD.

**CHILE:**  
PHILIPS CHILENA S.A.

**COLOMBIA:**  
PHILIPS COLOMBIANA S.A.

**COSTA RICA:**  
INDUSTRIA DE DISCOS  
CENTROAMERICANA

**DENMARK:**  
METRONOME RECORDS A/B

**ENGLAND:**  
POLYDOR RECORDS LTD.

**FRANCE:**  
DISQUES BARCLAY

**GERMANY:**  
METRONOME RECORDS G.m.b.H.

**GREECE:**  
HELLADISC S.A.

**HOLLAND:**  
POLYDOR NEDERLAND N.V.

**HONG KONG:**  
COSDEL (HONG KONG) LTD.

**ITALY:**  
RIFI RECORD CO.

**ISRAEL:**  
GAL RON LTD.

**JAMAICA:**  
DYNAMIC SOUNDS RECORDING CO., LTD.

**JAPAN:**  
NIPPON GRAMMOPHON CO. LTD.

**MEXICO:**  
DISCOS UNIVERSALES S.A.

**NORWAY:**  
AS NORDISC

**PERU:**  
EL VIRREY INDUSTRIAS MUSICALES S.A.

**PHILIPPINES:**  
MARECO, INC.

**PORTUGAL:**  
RADIO TRIUNFO LTDA.

**SINGAPORE:**  
COSDEL (SINGAPORE) LTD.

**SOUTH AFRICA:**  
TEAL RECORD CO. LTD.

**SPAIN:**  
HISPAVOX S.A.

**SWEDEN:**  
METRONOME RECORDS AB

**SWITZERLAND:**  
BARCLAY RECORDS S.A.

**TURKEY:**  
MELODI RECORDS

**VENEZUELA:**  
POLYDOR, S.A.

**WEST INDIES:**  
WEST INDIES RECORDS,  
(B'DOS) LTD.

**Atlantic Records, 1841 Broadway, New York, N.Y. 10023**

# EXPOSED: The International Motown Conspiracy.

The truth is out.  
Agents of the MOTOWN family of labels  
are in every corner of the world  
supplying the people of each nation  
with that intriguing MOTOWN sound.  
All roads lead from Detroit.  
The code word is "HITS."



- 
- ★ 1. MOTOWN HEADQUARTERS  
2457 Woodward Ave.  
Detroit, Michigan
  - 2. PHONODISC LIMITED  
30 Malley Road  
Scarborough, Ontario
  - 3. DISCOS CAPITOL DE MEXICO S.A.  
Ayuntamiento #54  
Mexico 1, D.F.
  - 4. DISCOS CENTROAMERICANOS S.A.  
Blvd. Ejercito Nacional, K.M.  
4 San Salvador, El Salvador,  
Central America
  - 5. DYNAMIC SOUNDS RECORDING CO., LTD.  
15 Bell Road  
Kingston 11, Jamaica
  - 6. INDUSTRIAS ELECTRICAS Y  
MUSICALES PERUANAS S.A.  
P.O. Box Apartado 67,  
Lima, Peru
  - 7. EL PALACIO DE LA MUSICA  
P.O. Box 3637  
Caracas, Venezuela
  - 8. CORPORACION DE RADIO DE  
CHILE S.A.  
Vicuna Mackenna 3333  
Casilla 1407  
Santiago, Chile
  - 9. TAPECAR GRAVACOES S.A.  
Rua 17 de Fevereiro 159-10  
Rio de Janeiro, GB, Brazil
  - 10. RCA VICTOR ARGENTINA  
Paroisseien 3960  
Casilla de Correo 4400  
Buenos Aires, Argentina



11. ELECTRIC & MUSICAL INDUSTRIES (DANSK-ENGELSK) A/S  
18 Hoffdingsvej,  
Copenhagen-Valby  
Denmark
12. S.A. GRAMOPHONE N.V.  
171 Blvd. Maurice Lemonnier  
Brussels 1, Belgium
13. BOVEMA  
Bronsteeweg 49  
Heemstede, Holland
14. (ARTIA)  
Ve Smeckach 30  
Praha 1, POB 30  
Czechoslovakia
15. E.M.I. (NORSK) A/S  
Frysjaveien 33,  
Postboks 42, Korsvoll  
Oslo 8, Norway
16. E.M.I. RECORDS  
E.M.I. House  
20 Manchester Square  
London, W 1, England
17. ELECTRIC & MUSICAL INDUSTRIES, LTD.  
4-5 Grosvenor Place  
London, SW 1, England
18. E.M.I. RECORDS (SWITZERLAND) A.G.  
Ramistrasse 42,  
8024 Zurich, Switzerland
19. OESTERREICHISCHE COLUMBIA  
GRAPHOPHON G.M.B.H.  
Fuhrichgasse 2,  
Vienna 1, Austria
20. ELECTROLA G.M.B.H.  
5 Koln-Braunsfeld  
Maarweg 149, Germany
21. ELECTRIC & MUSICAL INDUSTRIES  
SVENSKA AB  
Sandhammsgatan 39  
Box 27053  
Stockholm 27, Sweden
22. MELODI RECORDS  
Istaklal Caddesi 387  
Saka Selim Cikmasi 7, Beyoglu,  
Istanbul, Turkey
23. PATHE MARCONI  
19 Rue Lord Byron  
Paris 8e, France
24. RCA ITALIANA S.P.A.  
Via Tiburtina KM. 12  
Rome, Italy
25. PRODIKCIJA GRAMOFONSKIH PLOCA  
Beograd, Makedonska 21  
Yugoslavia



26. RCA ESPANOLA S.A.  
Torre de Madrid  
Planta 7a, Oficinas 8y9  
Madrid 13, Spain
27. COMERCIO E INDUSTRIA, S.A.R.L.  
R. Nova Do Almada 95-99  
Lisboa-2, Portugal
28. CBS RECORDS (ISRAEL) LTD.  
PO. Box 681  
Tel Aviv, Israel
29. SOCIETE LIBANAISE DU DISQUE  
Building Cinema Empire  
B.P. 4758  
Beyrouth, Lebanon
30. TEAL RECORD COMPANY  
PO. Box 4105  
Johannesburg, South Africa
31. THE GRAMOPHONE CO.  
OF INDIA, LTD.  
PO. Box 48  
Calcutta, India
32. COSDEL (JAPAN) LIMITED  
Room 503, Nikkatsu Intl. Bldg.  
1-1 Chome, Yuraku-Cho  
Chiyoda-Ku  
Tokyo, Japan
33. COSDEL (H.K.) LIMITED  
PO. Box 2567  
Honk Kong, B.C.C.
34. MARECO INC.  
131 Del Monte Avenue  
Quezon City, Philippines
35. COSDEL (SINGAPORE) LIMITED  
G.P.O. Box 2659  
Singapore 1
36. E.M.I. (NEW ZEALAND) LTD  
PO. Box 296  
162-172 Wakefield Street  
Wellington, New Zealand
37. E.M.I. (AUSTRALIA) LIMITED  
PO. Box 352  
Haymarket, N.S.W.  
Australia

# EXPOSED: The International Jobete Conspiracy.

The secret "material" ingredients in the Motown success story are created by the publishing double agents JOBETE (BMI), and STEIN & VAN STOCK, INC. (ASCAP). There are some territories still open for sub-publishers who won't keep this fact a secret.

If you act now, JOBETE will put your company on the map.

A stylized map of the Americas, including North and South America, is shown in white against a black background. Three specific locations are marked with small white stars and numbered. Star 1 is in the Detroit area, star 2 is in Mexico, and star 3 is in Brazil. The map also shows the outlines of the continents and some major cities.

★ JOBETE MUSIC CO. (BMI)  
Stein & Van Stock (ASCAP)  
2457 Woodward Ave.  
Detroit, Michigan 48201

2. GREVER INTERNATIONAL S.A.  
Insurgentes Sur No. 273-70  
Piso, Mexico 11, D.F.

3. EBRAU EDITORA BRASILEIRA  
AUTORES UNIDOS  
Rua Siqueira Campos, 143  
Rio de Janeiro, Brazil

4. IMPALA-BASART MUSIC N.V.  
Leidsegracht 11  
Amsterdam, Holland

5. CARLIN MUSIC CORP.  
17 Savile Row  
London, W1X 1AE, England

6. ABERBACH HAMBURG GmbH  
2 Hamburg 13  
Mittelweg 169, Germany

7. REUTER & REUTER FORLAGS A.B.  
Regeringsgatan 45,  
Stockholm, Sweden

8. LES EDITIONS ET PRODUCTIONS  
MUSICALES PATHE-MARCONI  
19 Rue Lord Byron  
Paris 8e, France

9. RCA ITALIANA S.P.A.  
Via Tiburtina KM. 12  
Rome, Italy

10. EDICIONES MUSICALES RCA  
ESPANOLA, S.A.  
Torre de Madrid, Planta 7a, Oficinas 8y9  
Madrid, Spain



12. TAIYO MUSIC INC.  
(Maruyama Bldg. 25)  
3-Chome Iikura  
Azabu Minato-ku  
Tokyo 106, Japan

11. LAETREC MUSIC LTD.  
124 President St.  
Johannesburg, South Africa

13. CASTLE MUSIC PTY. LTD.  
4th Floor  
381 Pitt Street  
Sidney, N.S.W. 2000, Australia

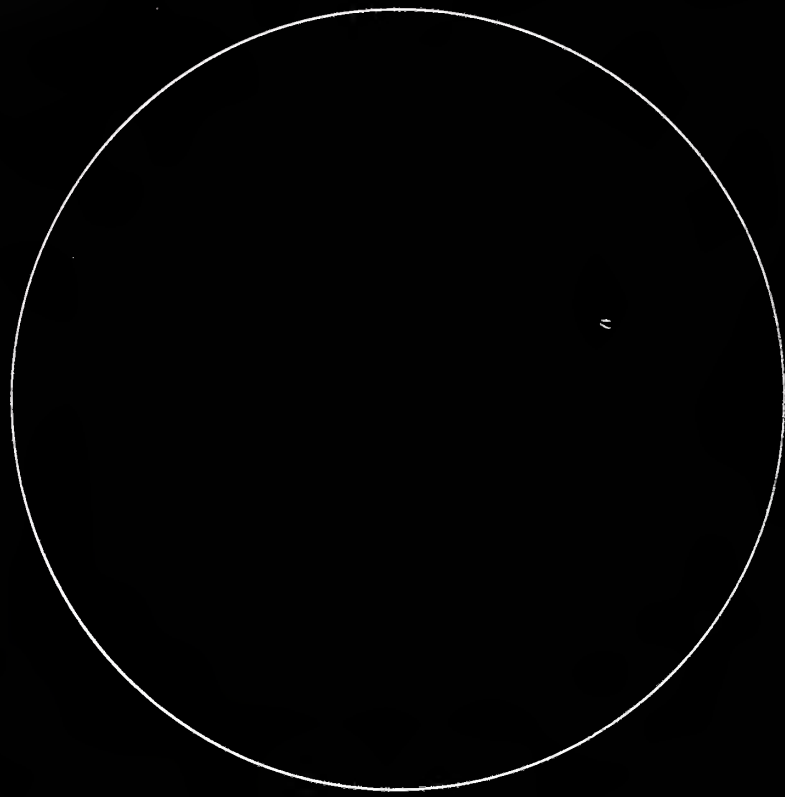

perfection



perfection



prognostion

# GERMANY: The Past 12 Months

The business on the German market is still healthy. The total sales rose about 9% over the previous year and close to about 138 million dollars worth of product was sold. Further-

## ENGLAND: PAST 12 MONTHS

(Con't. from Page 25)

Sparta Music's Hal Shaper and Jeff Kruger, boss of Ember Records, signed a deal merging their publishing interests via a new company to be known as Sparta Florida Music Group. Martin Davis named Managing Director of Liberty/UA, and Creedence Clearwater took Britain by storm giving Burlington Music yet another hit by the group with "Travelin' Band". Paul McCartney eventually left The Beatles after months of rumors.

### Future Directions

The future is clarifying itself in some directions. Cassettes and cartridges are going to grow bigger as more companies make massive commitments to this field. Disk retailers are going to diminish in number as the trade becomes aligned in favour of the big chains or the well organised specialist. Newly independent American labels here will learn some more hard lessons with quite possibly more major casualties before they can breathe easy in the British market. It's all in the game, like the song says.

more, about 1.74 million MusiCassettes were sold and, together with the turnover of the non-registered firms, the turnover increased to 560 million DM, that will say 151 million dollars.

The 12" LP is with the grand total of 94.8 million records (incl. export) leading with 51.1 million sold (+ 14.3%) and the sale of 40.8 million singles shows an increase of 10%.

The sale of low-priced LP's was much the same as those of the normal-priced ones but in the past year the low-priced LP's sales rose significantly. The turnover of normal priced LP's stagnated with 14.3 million.

The classical music sales reached 25.6% increase for the past year. In other European countries that field reached 20%. The sales of EP's and 10" LP's showed still a downward trend. By the export of 19.1 million records the 12" LP is leading.

On the single scene, 59 records made the top 10 in the last 12 months, compared to 89 records the year before.

Only about 32% of the songs listed were German original songs. As in the years before, record sales in large cities accounted for most of the English language volume with the kids all over the country favoring the foreign product.

On the LP scene it looks a little bit different. 36 LP's made the top 10 in the last 12 months on the LP charts. About 19 LP's that means 47%, were recorded in Germany. The events of the last 12 months were as follows:

Category	% Increase	SALES	
		1969 In Millions	1968 In Millions
Singles	+10.0	40.8	37.1
EP's	—	2.8	3.6
10" LP's	—	0.1	0.4
12" LP's	+14.3	51.1	44.7
<b>Total Amount</b>		<b>94.8</b>	<b>85.8</b>
<b>LOCAL SALES</b>			
Singles	+ 9.1	34.8	31.9
EP's	—	2.6	3.2
10" LP's	—	0.1	0.4
12" LP's	+14.4	38.2	33.4
<b>Total Amount</b>		<b>75.7</b>	<b>68.9</b>
<b>EXPORTS</b>			
Singles	—	6.0	5.2
EP's	+15.4	0.2	0.4
10" LP's	—	0.0	0.0
12" LP's	+14.2	12.9	11.3
<b>Total Amount</b>		<b>19.1</b>	<b>16.9</b>
<b>IMPORTS</b>			
Singles	—	0.26	0.33
EP's	—	0.02	0.04
10" LP's	—	0.00	0.01
12" LP's	—	2.43	2.25
<b>Total Amount</b>		<b>2.71</b>	<b>2.63</b>

### MUSICASSETTS-SALES 1969

1.75 Millions. Local sales and export share about 50% each.

## GERMANY'S TOP 10 HIT SINGLES IN THE LAST 12 MONTHS

(In order of appearance in the top 10 Not in order of sales or alphabetical order)

- Israelites — Desmond Dekker and the Aces — Ariola/Ember — Intro
- Ballad Of John and Yoko — The Beatles — Electrola/Apple — Budde
- \*Das Maedchen Carina — Roy Black — Polydor — Riva/Seith
- Aquarius/Let The Sunshine In — The 5th Dimension — Liberty — United Artists
- Get Back — The Beatles — Electrola/Apple — Budde
- \*Er steht im Tor — Wencke Myhre — Polydor — Hanseatic/Aberbach
- Michael And The Slipper Tree — The Equals — Ariola/President — AME-Kassner
- Dizzy — Tommy Roe — Columbia — Chappell
- Proud Mary — Creedence Clearwater Revival — Bellaphon — Burlington/Arends
- Pretty Belinda — Chris Andrews — Deutsche Vogue — Gerig
- \*Mendocino — Sir Douglas Quintett — Mercury — Altus/Global
- Oh, Happy Day — Edwin Hawkins Singers — Polydor/Buddah Records — United Artists
- Bad Moon Rising — Creedence Clearwater Revival — Bellaphon — Burlington/Arends
- Je'taime . . . moi non plus — Jane Birkin & Serge Gainsbourg — Fontana — Marbot
- Tomorrow Tomorrow — Bee Gees — Polydor — Slezak
- In The Ghetto — Elvis Presley — RCA Victor — B-n-B Music & Gladys Music
- \*Heute so, morgen so — Roberto Blanco — Deutsche Vogue — April
- Honky Tonk Woman — The Rolling Stones — Decca — Gerig
- In The Year 2525 — Zager & Evans — RCA Victor — Gerig
- Give Peace A Chance — Plastic Ono Band — Electrola/Apple — Budde
- Saved By The Bell — Robin Gibb — Polydor — Slezak
- \*Mendocino — Michael Holm — Ariola/Hansa — Altus/Global
- \*Geh' nicht vorbei — Christian Anders — Columbia — Toledo/Intro
- Don't Forget To Remember — The Bee Gees — Polydor — Slezak
- Sugar, Sugar — The Archies — RCA Victor — Intro
- \*Anuschka — Udo Juergens — Ariola — Montana
- \*Scheiden tut so weh — Heintje — Ariola — Maxim
- Venus — Shocking Blue — Metronome — Metorion
- Green River — Creedence Clearwater Revival — Ballaphon — Burlington/Arenda
- Something — The Beatles — Electrola/Apple — Apple
- \*Dein schoenstes Geschenk — Roy Black — Polydor — Gerig
- \*Weine nicht, kleine Eva — The Flippers — Bellaphon — Badenia/Comes
- Oh Well — Fleetwood Mac — Reprise — Fleetwood Music
- Come Together — The Beatles — Electrola/Apple — Budde
- (Call Me) Number One — The Tremeloes — CBS — Melodie der Welt
- Down On The Corner — Creedence Clearwater Revival — Bellaphon — Burlington/Arends
- Dynamite Woman — Sir Douglas Quintett — Mercury — Altus/Global
- \*Mademoiselle Ninette — The Soulful Dynamics — Philips — Sikorski
- Suspicious Minds — Elvis Presley — RCA Victor — Melodie der Welt
- Na Na Hey Hey Kiss Him Good Bye — The Steam — Fontana — Altus/Global
- Gruezi wohl, Frau Stirnimaa! — Die Minstrels — Columbia — Accord
- Rub A Dub Dub — The Equals — Ariola/President — AME Kassner
- Jingle Jangle — The Archies — Intro — RCA Victor
- Whole Lotta Love — Led Zeppelin — Metronome/Atlantic — Superhype Music
- Mighty Joe — The Shocking Blue — Metronome — SMV/Metorion
- I'm A Man — Chicago — CBS — Gerig
- Let's Work Together — Canned Heat — Liberty United Artists Music
- \*Die Maschen der Maedchen — Chris Roberts — Polydor — Riva/Seith
- Oh Lady Mary — Peter Alexander — Ariola — Marbot
- Let It Be — The Beatles — Electrola/Apple — Budde
- Travelin' Band — Creedence Clearwater Revival — Bellaphon — Burlington/Arends
- \*Ein kleines Glueck — Adamo — Columbia — Montana
- \*Barfub im Regen — Michael Holm — Ariola — Arabella
- Hosuse Of The Rising Sun — Frijid Pink — Decca — Gerig
- Bridge Over Troubled Water — Simon & Garfunkel — CBS — Altus/Global
- \*Du — Peter Maffay — Telefunken — Rahn
- All Kinds Of Everything — Dana — Decca — Montana
- I.O.I.O. — The Bee Gees — Polydor — Slezak
- Ma Belle Amie — Tee-Set — Ariola/Hansa — Intro

\*Original German copyrights

## GERMANY: The Past 12 Mos.

JUNE 1969

In Germany are at present about 15.5 million TV spectators. 340,000 of them are owners of colour TV re-

ceivers . . . Barry and Paul Ryan signed a contract with Polydor which runs over 1 million dollars. Barry is obliged to record during the next 3 years 72 sides and will get therefore 750,000 dollars and his brother Paul

(Con't. on Page 42)

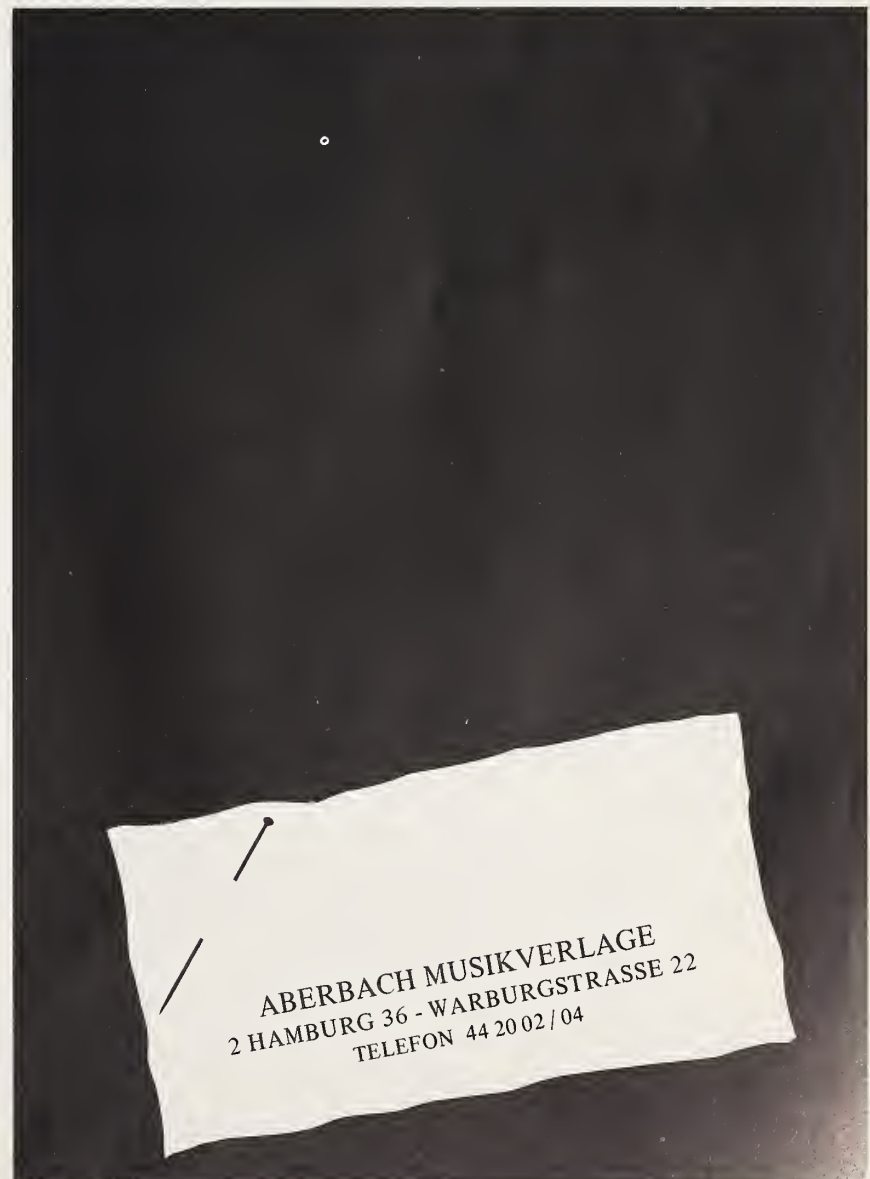

# GERMANY'S MUSIC PUBLISHERS

## ABERBACH MUSIKVERLAGE

Herr Otto Demler  
Warburgstrasse 22  
2 Hamburg 36  
Telephone: 442002

## AHN & SIMROCK BUEHNEN — UND MUSIKVERLAG

Frau Charlotte Eitel  
Meinekestrasse 10  
1 Berlin 15  
Telephone: 91 47 66

## APOLLO-VERLAG PAUL LINCKE

Werner und Erich Seifert  
Ostpreussendamm 26  
1 Berlin 45  
Telephone: 73 18 25

## AME-MUSIKVERLAG ED KASSNER & CO.

MUSIKVERLAG BROADWAY GMBH &  
BROADWAY-PLATTE GMBH  
Frau Barbara Kist  
Uhlhornstrasse 1  
3 Hannover-Kleefeld  
Telephone: 555262

## APRIL MUSIKVERLAG

Herr Rudolf Wolpert  
Palmengartenstrasse 4  
6 Frankfurt/Main  
Telephone: 775544

## PAUL C. R. ARENDS MUSIKVERLAG

Herr Michael Arends  
P. O. Box 20  
8211 Rimsting/Bavaria  
Telephone: 08051-634  
(Edition Trumpf-Burlington Musik)

## RALF ARNIE MUSIKVERLAGE

Star Musikproduktion  
Herr Ralf Arnie  
Wrangelstrasse 5  
Hamburg 20  
Telephone: 464041

## ATRIUM MUSIKVERLAG

Herr Felix Stahl  
Rothenbaumchausee 191  
2 Hamburg 13

## BAERENREITER VERLAG

Herr Dr. Karl Voetterle  
Heinrich-Schutz-Allee 33-37  
35 Kassel-Wilhelmshoehe  
Telephone: 3 00 11

## RICHARD BIRNBACH

Duererstrasse 28 a  
1 Berlin 45  
Telephone: 73 13 71

## BOETE & BOCK

Herr Dieter Langheld  
Hardenbergstrasse 9 a  
1 Berlin 12  
Telephone: 32 39 81

## BOOSEY & HAWKES

Herr Guenter Mott  
Kronprinzenstrasse 26  
53 Bonn  
Telephone: 3 44 24

## BOSWORTH & CO.

Fritz Hartmann  
Hohe Strasse 133  
5 Koeln  
Telephone: 21 14 79

## BREITKOPF & HAERTEL

Dr. Hellmuth von Hase  
Burgstrasse 6  
62 Wiesbaden 1  
Telephon: 5 92 41

## ROLF BUDE MUSIKVERIAGE

Herr Rolf Budde  
Hohenzollerndamm 54 a  
1 Berlin 33  
Telephone: 8865051

## EDITION ACCORD

Herr Rudolf Petry  
Lindenstrasse 19  
5 Koeln  
Telephone: 238067

## EDITION CANZONETTA

Frau Francisca Bochmann  
Petzower Strasse 13  
1 Berlin 39  
Telephone: 80 57 40

## CHAPPELL & CO.

Herr Dr. Michael Mueller-Blattau  
Marien Terrasse 1  
2 Hamburg 22  
Telephone: 22 25 15

## CAPRICCIO MUSIKVERLAG

Herr Peter Lach  
Warburgstrasse 22  
2 Hamburg 36  
Telephone: 4103662

## EDITION DOMA

Herr Bert Kaempfert  
Inselstrasse 4  
2 Hamburg 20  
Telephone: 516829

## EDITION ESPLANADE

Rathenaustrasse 25  
2 Hamburg 39  
Telephone: 518211  
Frau Liebe

## E.R.P. MUSIKVERLAG GMBH & CO.

Herr Eckart Rahn  
8 Muenchen 23  
Leopoldstrasse 28a/IV  
Telephone: 33 84 21

## EDITION INTRO

Peter Meisel Musikverlage  
Herr Peter Meisel  
Wittelsbacherstrasse 18  
1 Berlin  
Telephone: 8814057  
(Intro, Nero, Augustin)

## EDITION MIKADO

Herr Charly Niessen  
Belgradstrasse 86  
8 Muenchen  
Telephone: 342359

## EDITION MONTANA

Herr Hans R. Beierlein  
8 Muenchen 23  
Koniginstr. 121  
Telephone: 343036

## EDITION MODERN

Herr Hans Wewerka  
Franz Josefstrasse 2  
8 Muenchen 13  
Telephone: 346308

## EDITION MARBOT

Frau Erni Bilkenroth  
Bornstrasse 12  
2 Hamburg 13  
Telephone: 446606

## FRANCIS DAY & HUNTER

Frau Bornemann  
Mittelweg 149  
2 Hamburg 13  
Telephone: 4103084

## HANS GERIG MUSIKVERLAGE

Herr Hans Gerig  
Drususgasse 7/11  
5 Koeln  
Telephone: 234833

## GLOBAL MUSIKVERLAG

(Atus Musikverlag, Minor Musikproduktion, Fanfare  
Musikproduktion)  
Herr Peter Kirsten  
Nagelstrasse 4  
7 Stuttgart 1  
Telephone: 244905

## J. S. KORDULETSCH MUSIKVERLAG

Ickstattstrasse 23/II  
8 Muenchen 5  
Telephone: 26 41 23

## OTTO KUHL MUSIKVERLAGE

Herr Jack Joseph  
Am Hof 34/36  
5 Koeln  
Telephone: 212276

## WILL MEISEL MUSIKVERLAGE

Herr Rudolf Schroeder  
Wittelsbacherstrasse 18  
1 Berlin  
Telephone: 8832345  
(Meisel, Monopol)

## MELODIE DER WELT MUSIKVERLAGE

Herr Michel  
Grosse Friedbergerstrasse 23-27  
6 Frankfurt/Main  
Telephone: 287847

## MINERVA MUSIK

(TeQuila Musik)  
Herr Rudi von der Dovenmuehle  
Sebastianusstr. 29  
5021 Grosskronsdorf/bei Koeln  
Telephone: (02234) 6499

## MOZART-EDITION

Dr. Gustav Zagler  
Wittelsbacherstrasse 18  
823 Bad Reichenhall  
Telephone: 32 19

## PEER MUSIKVERLAGE

(Southern Music)  
Frau Gertraud Seeger/Herr Michael Karnstedt  
Muehlenkamp 43  
2 Hamburg 39  
Telephone: 279 10 44

## C. F. PETER

Dr. Johannes Petschull  
Kennedy-Allee 101  
6 Frankfurt S 10  
Telephone: 71 01 01

## G. RICORDI & CO.

Herr Ludwig Hinterschweiger  
Holzgraben 31  
6 Frankfurt  
Telephone: 2 35 08

## RECITE MUSIKVERLAG

Herr Gunter Beyer  
Friesenwall 19  
5 Koeln  
Telephone: 236036

## PETER SCHAEFFERS MUSIKVERLAGE

Sendlingerstrasse 23  
8 Muenchen 2  
Telephone: 262091

## B. SCHOTT'S SOEHNE

Weihergarten 1-7  
65 Mainz  
Telephone: 2 43 41

## AUGUST SEITH MUSIKVERLAGE

Herr August Seith  
Sendlinger-Torplatz 10  
8 Muenchen 2  
Telephone: 59 68 28

## RALPH MARIA SIEGEL MUSIKVERLAGE

Herr Ralph Maria Siegel  
Am Biederstein 7  
8 Muenchen  
Telephone: 476820

## ALFRED SCHACHT MUSIKVERLAGE

Adolfstrasse 45  
2 Hamburg  
Telephone: 2203704

## PAUL SIEGEL MUSIKVERLAGE

Herr Paul Siegel  
Tauentzienstrasse 15  
1 Berlin  
Telephone: 247029

## HANS SIKORSKI MUSIKVERLAGE

Herr Dr. Hans Sikorski  
Johnsallee 23  
2 Hamburg 13  
Telephone: 446245

## RUDI SLEZAK MUSIK

Frau Inge Mewes  
2 Hamburg 13  
Frauenthal 11  
Telephone: 458853

## SONG EDITION

Gustav Freytagstrasse 9  
1 Berlin  
Telephone: 893971

## SONOKLANG MUSIKVERLAG

Mainzer Landstrasse 87-89  
6 Frankfurt/Main 8  
Telephone: 235151

## TUTTI MUSIKVERLAG

Frau Gamber  
Eschersheimer Landstrasse 12  
6 Frankfurt/Main  
Telephone: 592996

## UFATON MUSIKVERLAGE

Herr Rudolf Foerster  
Sonnenstrasse 19  
8 Muenchen  
Telephone: 557957

## UNITED ARTISTS MUSIK

Frau Gaby Richt  
Herzog-Rudolph-Strasse 3  
8 Muenchen 22  
Telephone: 22 51 75

## VERLAG LUDWIG VOGGENREITER

Herr Heinrich Voggenreiter  
Meckenheimer Strasse 12  
532 Bad Godesberg  
Telephone: 1 23 43

## ENNO WINCKLER MUSIKEDITION

Herr Enno Winckler, Pres.  
Herbartstrasse 28  
1 Berlin 19  
Telephone: Hamburg 7224187



# WE ARE SUCCESSFUL!

## FOR TOP REPRESENTATION CONTACT:

EDITION ACCORD GMBH

5 KOELN 1 • LINDENSTR. 19

TEL: 238067 CABLE: ACCORDMUSIC KOELN



MUSIKVERLAG PLANETARY GMBH



# ALWAYS IN THE CHARTS AND STILL GROWING

RUDOLF SLEZAK MUSIKVERLAG GMBH

2000 HAMBURG 13 · FRAUENTHAL 11





He can be  
sure of business  
in Germany

He's got Ariola

Working with Ariola means success.

Because . . .

Ariola promotion uses new ideas.

Because . . .

Ariola distribution is spelled S. A. L. E. S.

So . . .

Make sure your product gets the right treatment.

Our treatment.

Then . . .

Watch your artists dominate our charts.

Like Ariola artists do.

Peter Alexander, Mireille Mathieu, Udo Jürgens,  
Rex Gildo, Heintje, Michael Holm, Ricky Shayne,  
The Hollies, The Equals, The Troggs, Apocalypse,  
Tee-Set, Vanity Fare,  
George Baker Selection, Desmond Dekker



# CORNET



is looking for record  
and publishing catalogs  
to be exclusively  
represented in Germany

## Cornet-Music GmbH & Co. KG

5022 Junkersdorf b. Cologne · Aachener Straße 112  
Telefon 02234 / 76076 · Telex Köln 8882059



**GERIG Musikverlage**  
5 Cologne · Germany  
Drususgasse 7-11

... is still

# THE TOP

in Germany

## GERMANY'S RECORD MANUFACTURERS, PRODUCERS AND THEIR ARTISTS

### ARIOLA-EURODISC GMBH

8 Muenchen 81, Arabellastrasse 4  
Telephone: 91 10 71  
(Ariola, Athena, Eurodisc, Melodia, Baccarola, Hansa, Supraphon, Maritim, Ariston, Embassy, Beacon, Cetra, Fonit, Joy, Laurie, Major Minor, Pama, Page One, President, Spark, Sonet, TWR, Blue Note, Cupol, Durium, harmonia mundi, Liberty, United Artists, Nashville, Minit, Request Records, RTB, Supreme, World Pacific)  
General Managers: Egmont Lueftner/Friedrich Schmidt  
Production Chief Classic: Fritz Ganss  
Production Chief Pop: Hans Georg Ehmke

**FRITZ GANSS, BERLIN:**  
Anna Moffo, Margit Schramm, Rudolf Schock, Robert Stolz

**HEINZ ALISCH, BERLIN:**  
Peter Alexander, Hanna Aroni, Helga und Klaus

**KURT FELTZ, KOELN:**  
Peter Alexander, Anna Moffo

**FRANZ SCHMIDT-NORDEN, HAMBURG:**  
Renaute u. Werner Leismann, Jo Ment, Stig Hallen, Ann Louise Hanson

**GIORGIO MORODER, BERLIN:**  
Michael Holm, Apocalypse, Tim Elton, Adriano Celentano, Uschi Glas

**GUENTER VORWERGK, BERLIN:**  
Folklore

**GERD HAEMMERLING, BERLIN:**  
Mireille Mathieu

**HANS R. BEIERLEIN (MONTANA), MUENCHEN:**  
Udo Juergens

**THOMAS MEISEL, BERLIN:**  
Rex Gildo, Mike Kennedy

**WOLFGANG ROLOFF, BREMEN:**  
Heintje, Sigi Hoppe

**HANSA MUSIK, BERLIN:**  
Marion, Nini Rosso, Ricky Shayne, Gaby Berger, Tony Marshall

**TWR (HORST FUCHS), BERLIN:**  
Fred Bertelmann, Rainer Thomas, Fausti, Karin Huebner, Wolfgang Gruner

### BELLAPHON RECORDS

6 Frankfurt, Mainzer Landstrasse 87-89  
Telephone: 23 51 51  
(Bellaphon, Condor, Admiral, America, Savoy, Aida, Auditorium, Bel Air, Belvedere, Visadisc)  
(No information about producers and artists)

### DEUTSCHE AUSTROPHON

284 Diepholz/Hann.  
Auf dem Esch 8  
Telephone: (05441) 344  
(Elite Special, Triola)  
General Manager: Rolf Neumann

**PRODUKTION NORD, HAMBURG:**  
Henry Vahl, Heidi Kabel, Hein Timm, Gundi Hein, Adriano Valle, Fifi Brix, Eckart Kahlhofer, Hai & Topsy, The Dynamic 6+1

**PRODUKTION FRANKFURT:**  
Oscar Muller, Grossner-Duo, Loni & Franzl, Brock-Terzett

**PRODUKTION MUENCHEN:**  
Die 3 Lausbuben, Das Bechteler-Trio, Die Illerspatzen

**PRODUKTION WIEN:**  
Peter Kreuder, Boris Rubaschkin, Heinz Sandauer, Julius Herrmann und die Original Hock-und Deutschmeister

**PRODUKTION ZUERICH/BASEL (TURICAPHON):**  
Hula Hawaiians, Ciccadilly-Six, Therese Wirt von Kaenel, Valter Skok und sein Oberkriener-Sextett

**WENDY STERN PRODUCTIONS:**  
Boddy Astor, Hammondorgel

### CBS SCHALLPLATTEN

6 Frankfurt, Sontraerstrasse 18  
Telephone: 41 71 21  
(CBS, Linda, Maris, Scout, Blue Horizon, Vee Jay, Amy, Arhoolie, Bell, 20th Century-Fox, Epic, Fillmore, Mala, Metromedia, Milestone, Movietone, New Voice, Odyssee, Okeh)  
General Manager: Rudolf Wolpert  
(No informations about producers and Artists were given)

### CORNET MUSIC

5022 Junkersdorf bei Koeln, Aachener Strasse 112  
Telephone: (02234) 76076  
(Cornet, Cornet Special, Cornet International)  
General Managers: Heinz Gietz/Guenter Ilgner  
Production Chief: Heinz Gietz

**HEINZ GIETZ, KOELN:**  
Jacqueline Boyer, Vivi Bach und Dietmar Schoenherr, Jay Five, Marie Christina, Curd Borkmann, Chris Howland, Rocco Granata, Bill Ramsey, Benny Maro, Ilja Kostar

**FRIEDEL BERLIPP, KOELN:**  
Roland W., Jay Walker, Camillo Felgen, Teeny, Sandra & Sharon

**WOLFGANG HIRSCHMANN, KOELN:**  
Horst Muys/Lotti Krekel, The Boston, Jette Franka, Joyce Suma

**HORST HEINZ HENNING, OBERTIEFENBACH:**  
Jarmilla Gerlova

### DEUTSCHE VOGUE GMBH

Zur Muhle 2  
5021 GroBkonigsdorf b. Koln  
Telephone: (02234) 3961  
(Vogue, Pye, Durium, Seeco Music, Clan, Red Bird, Dot, Roulette)  
General Manager: Guy Khavessian

**PRODUCERS:**  
**RICHARD DANNER, WURZBURG:**  
The Cry n Strings, Helmut Schmidt, Wolf Jung

**OTTO DEMLER, HAMBURG:**  
Andy Fisher

### DEUTSCHE VOGUE (Con't)

**RUDI VON DER DOVENMUHLE, KOLN:**  
Valerie Pascal  
Hans Jurgen Baumler, The Casey Jones Government

**PETER KIRSTEN, STUTTGART:**  
Peter Horton

**TONY HENDRIK, KOLN:**  
Tony Hendrik, Ron Gordon, Chris Conway, Angela, Tommy York

**RALPH SIEGEL JR., MUNCHEN:**  
Michell, The Blackberries

**JACK WHITE, BERLIN:**  
Bob Telden, Roberto Blanco, Renee Martin

**MIKI DALLON, LONDON:**  
Don Fardon, The Chantelles, Tony Ritchie

**BILL WELLINGS, LONDON:**  
John Smith and the New Sound, Jon and Jeannie

### DEUTSCHE GRAMMOPHON/ POLYDOR

**DEUTSCHE GRAMMOPHON  
GESELLSCHAFT MBH (DGG)**  
Head Office: 2 Hamburg 13  
Harvestehuder Weg 1-4  
Telephone: 44 14 21  
Cable Address: Grammophon Hamburg  
Telex: 021 2434  
Managing Directors: Coen Solleveld, Hans-Werner Steinhilber, Johannes Ven Der Velden, Kurt Kinkele (Deputy)

(Direction Germany)

2 Hamburg 13, Rothenbaumchaussee 5  
Telephone: 44 17 91  
(Deutsche Grammophon, Archiv, Heliodor, Literarisches Archiv, Karussell, Tip, Polydor, Kuckuck, Chess, Buddah, Kama Sutra, MGM, Verve, A&M, Riverside, Storyville, Palette, Hispavox, Ricordi)  
General Manager: Richard Busch  
Production Chief Klassik: Dr. Hans Hirsch  
Production Chief Pop: Oskar Drechsler

**HANS BERTRAM, KOELN:**  
Roy Black, Kallmann-Chor, Willy Millowitsch, Chris Roberts, Heinz Schachtner

**UDO BOWIEN, HAMBURG:**  
Franz J. Degenhardt, Max Greger, Ilja Richter, Swetlana, Adolf Scherbaum, Horst Wende, Roberto Delgado, Conchita Bastista

**A. BUDDER, BERLIN:**  
Teddy Lee

**OTTO DEMLER, HAMBURG:**  
Karel Gott, Marta Kubisova

**KURT FELTZ, KOELN:**  
Rene Carol, Ingeborg Hallstein, Kim, Martin Lauer, Lolita, Waldemar Matuska, Peter Rubin, Dagmar Koller

**HANNS HUBER, MUENCHEN:**  
Muenchner Lach-u. Schiessgesellschaft, Sepp Viel-lechner, Thomas Piper

**GIBSON KEMP, HAMBURG:**  
Golden Kids, Napoleon Smith, Valendras, Heiena Waschek

**PETER KIRSTEN, STUTTGART:**  
Peter Horton, Marek & Vacek, Joy Unlimited

**HANS LAST, HAMBURG:**  
James Last, Wonderland

**WERNER LAST, HAMBURG:**  
Waltraud Dirks, Renata Kern, Ivo Robic, Kai Warner

**GERHARD MENDELSON, MUENCHEN:**  
Gus Backus, Gigliola Cinquetti, Connie Francis, Freddy, Milva, Rita Pavone

**WOLFGANG MEWES, FRANKFURT:**  
Barbi Glueck, Bata Illic, Laurent Rossi, Peter Wolf

**BOBBY SCHMIDT, HAMBURG:**  
Wencke Myhre, Medium-Terzett, Dagmar Koller, Fritz Schulz-Reichel

### ELECTROLA GMBH

**ELECTROLA GMBH**  
5 Koeln-Braunsfeld, Maarweg 149  
Telephone: 49 31 31  
(ABC, Apple, Bluesway, Capitol, Columbia, Cornet, Dot, Dunhill, Electrola, Enterprise, Grand Award, Hor zu, Harvest, Impulse, Immediate Isarton, Odeon, Orange, Preiser, Paramount, Dacapo, Stax, State-side, Tamla Motown, Tangerine Records, Volksplatte, Vanguard, Walt Disney)  
General Managers: Dr. Gerhard Hundertmark/Wilfried Jung  
Production Chief Klassik: Dr. Helmut Storjohann  
Production Chief Pop: John Moehring

**NILS NOBACH:**  
Adamo, Lale Andersen, Mal Anthony, Bonny St. Claire, Wanda Jackson, Ray Miller, Brigitt Petry

**ERICH OFFIEROWSKY:**  
Adam & Eve, The Buffoons, Guenther Frank, Arne Jansen, Carl Linstroem, Pedro, Friedrich Schuetter

**JOCHEN HEIDER:**  
Christian Anders, Regine

**KURT FELTZ:**  
Michael Heymann, Marika Lichter, Ralf Bendix

**GUENTER NORIS:**  
Gitte, Britt Miamkjell, Guenter Noris

**PETER MEISEL:**  
Howard Carpendale, Erik Silvester

**EDITION MONTANA:**  
Gilbert Beaud

**HANS BLUM:**  
Peter Beil

**RALF BENDIX:**  
Heino, Die Contis

**HELMUT ZACHARIAS:**  
Helmut Zacharias

(Con't. on next page)

# GERMANY'S RECORD MFRS. (Con't)

(Con't. from Page 38)

## HANSA MUSIKPRODUKTION

1 Berlin 31, Wittelsbacherstrasse 18  
Telephone: 881 40 57  
(Hansa)  
General Manager: Peter Meisel  
Producers: Peter Meisel, Thomas Meisel, Joachim Heider, Guenter Henne, Gerhard Haemmerling, Jack White

Artists: Manuela (Telefunken), Marion (Hansa), Gerd Boettcher (Metronome), Giorgio (Hansa), Nini Rosso (Hansa), Ricky Shayne (Hansa), Andy Star (Metronome), Siw Malmkvist (Metronome), Anna-Lena (Metronome), Nina Lizell (Metronome), Erik Silvester (Electrola), Howard Carpendale (Electrola), Rex Gildo (Ariola), Mireille Mathieu (Ariola), Christian Anders (Electrola), Jack White (Polydor), Pat Simon (Metronome), Gaby Berger (Hansa), Tony Marshall (Ariola), Xhol Caravan (Hansa), Jack White (Polydor)

## LIBERTY/UA GMBH

8 Muenchen 22, Herzog-Rudolf-Strasse 3  
Telephone: 22 13 61  
(Liberty, United Artists, Sunset, Minit, Blue Note, Solid State, World Pacific Jazz)  
General Manager: Siegfried E. Loch  
Production Chief: Siegfried E. Loch/Gerhard Augustin

**SIEGFRIED E. LOCH:**  
Suzanne Doucet, Paul Nero, Klaus Doldinger, Krokodil, Don Paulin, Vic Dana

**CHRISTIAN BRUHN:**  
Katja Ebstein

**HEINZ KIESSLING:**  
Lester Wilson

**ABI OFARIM:**  
Shade, The Can

## MCA RECORDS/MILLER

### INTERNATIONAL

2085 Quickborn bei Hamburg,  
Justus-von-Liebig-Ring 2-4  
Telephone: (04106) 2885  
(MCA, Coral, Europa, Somerset)  
General Managers: Harald A. Kirsten/Franz J. Elmen-dorff  
Production Chief: Norman Douglas

**ARTISTS:** Josef Laufer, Tracy, Gissy Andre, Karl Heinz Hess, Leapy Lee, Barry Mason & Sylvian, Karen Wymann, The Skorpions, Frank Valdor, The Hearts of Soul, Peter Sydan, Hardy Kingston, John & Ann Ryder, Andres Segovia

## METRONOME RECORDS

2 Hamburg 1, Heidenkampsweg 76 b  
Telephone: 24 12 61  
(Metronome, Atlantic, Barclay, Golden 12, Atco, Mondial)  
General Manager: Leif Kraul  
(No informations about producer and artists were given)

## MONTANA

8 Muenchen 23, Koenigstrasse 121  
Telephone: 34 30 36  
General Manager: Hans R. Beierlein  
Promotion/Intern. Department: Dieter Weidenfeld  
Artists: Udo Juergens, Gilbert Becaud, Sacha Distel

## MPS-RECORDS

7730 Villingen/Schwarzwald,  
Richthofenstrasse 3  
Telephone: (07721) 52007  
(MPS, MPS, Klassik, Session, Center, Top Five, Prestige, Octave)  
General Manager: Hans Georg Brunner-Schwer  
Production Chief: Willi Fruth  
Artists: Friedrich Gulda, Oscar Peterson, Clarke-Boland  
Big Band, Dave Pike Set, Ambros Seelos Show-Band

## PHONOGRAM TON GMBH

2 Hamburg 1, Moenckebergstrasse 7  
Telephone: 33 92 21  
(Philips, Fontana, Vertigo, Mercury, Fass, Pergola, Island, Penny Farthing, Mirtó, Contemporary, Good-time Jazz)  
General Manager: Dr. Werner Vogelsang  
Production Chief: Wolfgang Kretzschmar

**FRED WEYRICH, HAMBURG:**  
Jorgen Edman, Francoise Hardy, Edina Pop, Dorthe, Thereza

**LEO LEANDROS, HAMBURG:**  
Blue Diamonds, Vicky Leandros

**HERBERT HILDEBRANDT, HAMBURG:**  
Lee Patterson Singers, Tony, The Rattles, Hajo, The Tonics, The Soulful Dynamics

**HORST HARTMANN, PORZ BEI KOELN:**  
Lisbeth List, Gerhard Wendland, Travellers

**CLIVE WESTLAKE:**  
Heidi Bruehl

**KONNI AMBERG, HAMBURG:**  
Roger Bean, Bela Sanders, Franz Lambert

**EGON L. FRAUENBERGER, MUENCHEN:**  
Orch. Peter Covent, Franz Lang

**ESTHER OFARIM:**  
Esther Ofarim

**HORST HEINZ HENNING:**  
Eric Thomas

**HANNS HUBER, MUENCHEN:**  
Marcia Griffiths, The Reggaes

## SPECIAL RECORD GMBH

8023 Pullach bei Muenchen, Rotwandstrasse 16  
Telephone: (0811) 79 42 66  
(Tempo, Special-Record, Osca)  
General Manager: Kurt Meissner  
Artists: Herbert Hisele, Maria Hellwig, Ernst Jaeger, Fred Rauch, Kathi Prechtl, Frank Pleyer, Franz Lof-fler

## TELDEC-SCHALLPLATTEN GMBH

(Telefunken-Decca)  
2 Hamburg 19, Heussweg 25  
Telephone: 4 01 91  
(Telefunken, Decca, RCA Victor, London, Warner Bros., Reprise, Scepter, Deram, Monument, Chapter One, Resono, Threshold)  
General Managers: Hans Lieber/Kurt Richter  
Production Chief Klassik: Dr. Gerhard Slavik  
Production Chief Pop: Bert Varell  
Public Relations: Guenther Braeunlich  
(No information about producers and artists were given)

## GERMANY'S TOP ALBUMS IN THE LAST 12 MONTHS

(In order of appearance on charts. Not in order of sales)

- \*Non Stop Dancing 8 — James Last — Polydor
- \*Udo Live — Udo Juergens — Ariola
- The Fantastic 5th Dimension — Liberty/Stern-Musik — The 5th Dimension
- \*Haare — Verschiedene Interpreten — Polydor (Deutsche Originalaufnahme)
- \*Heintje — Heintje — Ariola
- Hair (Original-Sound-Track) — Verschiedene Interpreten — RCA Victor
- \*Die goldene Stimme aus Prag — Karel Gott — Polydor/Stern-Musik
- \*Ich hab' dich lieb — Roy Black — Polydor
- The Beatles — The Beatles — Electrola/Apple
- \*Hammond Pops II — Klaus Wunderlich — Telefunken
- The Age Of Aquarius — The 5th Dimension — Liberty
- \*Schlager-Rendezvous mit Peter Alexander — 1. Folge — Peter Alexander — Ariola
- \*Heintje-Ich sing' ein Lied fuer dich — Heintje — Ariola
- \*Udo '70 — Udo Juergens — Ariola
- \*Sehnsucht — Alexandra — Philips
- Blind Faith — Blind Faith — Polydor
- \*Aennchen von Tharau II — James Last — Polydor
- Abbey Road — The Beatles — Electrola/Apple
- \*Im Land der Lieder — Peter Alexander — Ariola
- \*In mir klingt ein Lied — Karel Gott — Polydor
- \*Non Stop Dancing 9 — James Last — Polydor
- Let It Bleed — The Rolling Stones — Decca
- \*Stunde der Stars — Verschiedene Interpreten — Ariola
- \*Concerto d'amour — Roy Black — Polydor
- Die grobe und aktuelle Starparade '69/4 — Polydor
- Led Zeppelin II — Led Zeppelin — Metronome/Atlantic
- Stand Up — Jethro Tull — Philips
- Ssssh — Ten Years After — Teldec/Deram
- \*Vergibmeinnicht (Sternstunde der Musik) — Verschiedene Interpreten — Polydor
- Bridge Over Troubled Water — Simon & Garfunkel — CBS
- Spirit Orgasmus Of Jeronimo & Creedence Clearwater Revival — Bellaphon
- The Best Of Creedence Clearwater Revival — Bellaphon
- \*Golden Non Stop Dancing 10 — James Last — Polydor
- Mireille Mireille — Mireille Mathieu — Ariola
- Easy Rider (Original-Sound Track) — Verschiedene Interpreten — Columbia
- \*Schlager-Rendezvous mit Peter Alexander 3. Folge — Ariola

\*German Recordings

# FOR GERMANY, AUSTRIA AND SWITZERLAND

## PETER KIRSTEN'S



# GLOBAL MUSIK GmbH

## 7000 Stuttgart 1 · Nagelstrasse 4

## Tel. 0711-244905 · Telex 07-21573

## Cable Adress: Globalmusic

AFFILIATES: ALTUS MUSIC · FUND OF MUSIC · FANFARE MUSIC  
GLOBE ART MANAGEMENT-ARTIST PROMOTION

# We're Internati

## And to us the

### Famous-Chappell Limited

Arrived:

The French motion picture hit of the year, soon to be released worldwide

*Borsalino*

Composed by Claude Bolling

Published by Famous/Chappell

Starring Alain Delon and Jean Paul Belmondo

Arriving:

**DARLING LILI**

Composed by Henry Mancini  
and Johnny Mercer

Published by Famous/Chappell

Starring Julie Andrews and Rock Hudson

Arriving:

**NORWOOD**

Composed by Mac Davis and  
Mitchel Torok

Published by Famous/Chappell

Starring Glen Campbell and Kim Darby

Arriving:

**"LITTLE FOSS AND BIG HALSEY"**

Composed by Johnny Cash and  
Carl Perkins

Published by Famous/Chappell

Starring Robert Redford and Michael J. Pollard

Leslie Gould

Managing Director and Chairman of the Board

#### Famous/Chappell World Wide Offices

LONDON  
50 New Bond Street  
London W1, England

FRANCE  
4 Rue de Argenson  
Paris 8, France

CANADA  
14 Birch Avenue  
Toronto 7, Canada

# onally Famous world is Paramount

## Famous Music (U.K.) Ltd.

A Subsidiary of Famous Music Corporation

A GULF+WESTERN COMPANY



**Paramount  
Records**  
A GULF + WESTERN COMPANY  
A DIVISION OF  
FAMOUS MUSIC CORP.



A DIVISION OF FAMOUS MUSIC CORP.



Distributed Exclusively by Paramount Records  
A DIVISION OF FAMOUS MUSIC CORP.  
A GULF + WESTERN COMPANY

and coming , the Famous label , soon to be released in the U.K.

Leslie Gould: Director of International Operations

Famous Music Ltd.  
162-170 Wardour St.  
London W1 England

### International Offices

Columbia Record Club Ltd.  
1121 Leslie Street  
Don Mills 5, Ontario, Canada

Cosdel (Hong Kong) Ltd.  
P. O. Box 2567  
Hong Kong

Cosdel (Japan) Ltd.  
Room 503  
Hibiya Park Building  
Tokyo, Japan

Cosdel (Singapore) Ltd.  
P. O. Box 2659  
Singapore

Cosdel  
P. O. Box 1712  
Bangkok, Thailand

Dischi Ricordi S.P.A.  
Via Berchet, 2  
Milano 20121, Italy

Discos CBS S. A.  
Apartado Aereo 15756  
Bogota, Columbia

Discos Rge Ltda.  
Avenida Ipiranga 1123  
Soa Paulo, Brazil

Disques Artone Fonoplaten N.V.  
20-21, Oudewijnlaan  
Brussers 1, Belgium

Eastonics, Ltd.  
P. O. Box 21029  
Tel Aviv, Israel

Electrola Gesellschaft M.B.H.  
Maarweg 149  
D-5 Cologne-Braunsfeld, Germany

E.M.I. Records, Ltd.  
4-5 Grosvenor Place  
London, S.W.1., England

E.M.I. Records Ltd.  
E.M.I. House  
20 Manchester Square  
London W1A-1ES, England

E.M.I. Records Ltd.  
Byth Road  
Hayes, Middlesex, England

Electric & Musical Industries, Ltd.  
(Dansk-Engelsk) A/S  
Hoffdingsvej 18  
2500 Valby  
Copenhagen, Denmark

E.M.I. Suomen Osasto  
c/o Teledict  
Kuortancenkatu 13  
Helsinki 51, Finland

E.M.I. (Lebanon) S.A.L.  
P. O. No. 6062  
Beirut, Lebanon

E.M.I. (Nigeria) Ltd.  
P. O. Box 417  
Apapa, Nigeria

E.M.I. (Norsk) A/S  
Frysjaveien 33  
Postboks 43  
Korsvoll, Oslo 8, Norway

'E.M.I. Ltd. Svenska A.B.  
P. O. Box No. 27053  
Stockholm 27, Sweden

Emaig Verkauf-A.G. Der E.M.I. Ltd.  
Bahnhofstr 28  
6300, Zug, Switzerland

Festival Records Pty. Ltd.  
P. O. Box 16  
Pymont N.S.W. 2009  
Sydney, Australia

Festival Records, New Zealand, Ltd.  
P. O. Box 1170  
Auckland, New Zealand

Gramofon Limitet Sirket  
P. O. Box No. 3  
Yesilkoy  
Istanbul, Turkey

The Gramophone Co. of India Ltd.  
P. O. Box 699  
Calcutta 28, India

Greek Phonograph Record House  
Platis Colocotroni  
TT 125  
Athens, Greece

Hispavox S/A  
Torrelaguna, 102  
Madrid 17, Spain  
(also Portugal)

Industria de Discos Centroamericana S. A.  
Apartado 4093  
San Jose, Costa Rica

La Discoteca  
Apartado 70948  
Caracas, Venezuela

Les Industries Musicales Et. Electriques  
Pathe Marconi  
19, Rue Lord Byron  
Paris 8e, France

Mico Industries, Inc. (Cosdel)  
P. O. Box 2364  
Manila, Philippines

N.V. Ngram-Delta  
Zijlweg 154  
P. O. Box 345  
Haarlem, Holland

Quality Records Ltd.  
380 Birchmount Road  
Scarborough, Ontario, Canada

RCA, S. A. de C. V.  
Apartado No. 17-570  
Mexico 17, D. F.

Record Specialists Ltd.  
1 Torrington Road  
Kingston, Jamaica, West Indies

Sicamericana S. A.  
Jose E. Uriburu 40-42  
Buenos Aires, Argentina

Trutone (Pty) Ltd.  
P. O. Box 9299  
Johannesburg, South Africa

# ITALY: The Past 12 Months

The 27th anniversary edition of Cash Box noted the most encouraging and optimistic perspective for the future of Italian industry, and not only for music. Italy was considered at that time, together with Germany and Japan, a very strong economical power with a very strong currency. National gross product was expected to increase in 1969 nearly 7%, and from many international authorities came word that Italy would revalue her Lira at the same time as the German Mark (The Economist, August 1969). Now, June 1970, we know that the apparent increase of National Gross Product for 1969 was less than 5% and that the Italian Lira has lost over 4% of its value. In the meantime the cost of living from May '69 to Jan. '70 (last official data available) jumped 3.7% against

an increase of 2.6% from Sept. 1967 to May 1969. The causes of such an inversion are generally considered the social turmoils that have shook Italy since eleven months. From 1969 summer until Christmas, about three hundred million hours per workers had been lost, according to available data, with a net loss, for workers' pockets, of roughly 330 million dollars. The total cost of "Hot Autumn" are considered pretty near to one billion dollars. When one considers that the population amounts to 50 million one discovers that each Italian citizen suffered a loss of 20 dollars during 1969. Unfortunately, strikes are still heavy and general, and from many parts a crisis is expected. The forecasts for our economical weather are dark.

With such a background, we should

think that the last twelve months were a true disaster for our music industry, but, although a reduction of sales was reported, the record industry was capable of reaction. Italy had a remarkable drop of single sales, which were good only after Canzonissima and San Remo, with few exceptions like Phonogram's autumn with Johnny Hallyday and Georges Moustaki; but we noted a steady increase in albums figure and the explosion of pre-recorded tapes.

It is a true pity that in Italy it is not possible to have official data about the record market. This fact is probably due to the distrust of the use of such data from many industries, and to lack of professional mind in others. Anyway, according to unofficial information, we may consider that reduc-

tion of single sales for normal market was near to 25%, but was over 50% for low price market and covers market. On the contrary, album sales probably increased 20% (for some companies the increase has reached nearly 50%) and we may think that in Italy the proportion between singles and albums could be 8:1, which is the lowest in the western hemisphere. On pre-recorded tapes, we probably have a very good position, in Europe at least, for Italy has two different markets, both in fast expansion. The Philips system is leading, but RCA cartridges had last year a very good increase in sales. The proportion between pre-recorded tapes and albums is, in case of albums and tapes similar in prices, 1:4. But in many cases we discover that an album cannot be sold at a price of 3 dollars, while the same cassette has a market at over 5 dollars!

Classical music has largely helped the development of the album and tape market, and Beethoven's bicentenary is proving a good promotional medium, but to attain real satisfactory sales we must have a couple of such events each year.

In publishing, the main fact of last twelve months was the end of an era in the administration of mechanical rights. Sedrim, Italian agent of Biem, disappeared and Siae, which was involved only in performing rights, has taken its place. By the way, Siae was already involved in collecting many rights (besides performing) and taxes on books, public entertainment, shows, etc., and it is also a State Agency. This particular position gives to Siae a greater power to inquire and a larger authority to intervene, and that is very important to prevent underhanded sales. We know that record market had a serious drop, but many publishers expect to receive higher figures for mechanical rights. Likely they will not, but this may give an idea of the damage caused by covers and unfair and underhanded sales.

## GERMANY: The Past 12 Mos.

(Con't. from Page 35)

as composer and author 250,000 dollars . . . The composer **Werner Eisbrenner** and the texter **Willy Dehmel** got as special awards the "GEMA-Ehrenring" . . . For the first time in the history of Switzerland a golden disk was awarded to the young **Heintje (Ariola)** for 200,000 sold LP's.

### JULY 1969

**Siegfried E. Loch**, chief of Liberty Record GmbH and his team celebrated 2-years-existence . . . The Deutsche Sage-OPP Records GmbH was renamed in Deutsche OPP Records GmbH and took over the distribution of their productions by themselves. For the distribution in Austria also in the future the firm Centrocord is responsible and for Switzerland the Phonag AG . . . Winners of the German hit competition 1969 are:

1. **Roberto Blanco**: (Deutsche Vogue): "Heute so, morgen so" by **Gerd Schmidt** and **Guenter Loose**, 2. **Paola (Teldec)**: "Stille Wasser, die sind tief" by **Guenter Sonneborn** and **Werner Raschek**, 3. **France Gall (Teldec)**: "Ein bisschen Goethe, ein bisschen Bonaparte" by **Christian Bruhn** and **Hans Bradtke**. 432 titles were given in. 24 of them came into the preliminary decision . . . **Hans-Georg Ehmke** has become pop-chief of Ariola/Eurodisc . . . The very promising young talent **Alexandra** died in a traffic accident.

### AUGUST 1969

From the 29th of August till 7th of September the German Radio exhibition take place in Stuttgart . . . **Flamingo Music**, **Frank Valcher**, is the name of a new founded music publishing house in Munich . . . **Hans-Werner Funke**, at present most successful German tournee and concert organizer celebrated his 10 years anniversary . . . The seven biggest German record firms, which are collected

in a working pool, made a contract over five years with the Sender Freies, Berlin, which includes that each year in co-operation the "Gala Abende der Schallplatte" will be held in Berlin and be transmitted in colour by the German TV and it will be overtaken by about 20 countries of Eurovision (West) and Intervision (East). The programming plans a change of Gala Abende classic and pop each years, on which many international stars of the music scene shall participate . . . **Wolfgang Wagner**, the chief intendant of the "Bayreuther Festspiele" was on the 30th of August 50 years old.

### SEPTEMBER 1969

Phonogram expanded their import service. An exploitation contract between Phonogram Tongesellschaft mbH and Contemporary Records Inc., Los Angeles has been concluded . . . The winners of the Loewen (lion) award of Radio Luxemburg, which

(Con't. on Page 46)



we  
do make  
world wide  
successes





**DISCHI RICORDI S.p.A.**

---

the



**YOUNG**  
companies  
with an



**OLD**  
tradition

**G. RICORDI & C.**  
**publishing companies**

---

via berchet 2 - 20121 milano - italy - tel. 893366 / 898242

# ITALY'S MUSIC PUBLISHERS

## ABBATE

Galleria del Corso 2, 20122 Milano  
Tel: 709491  
General Manager: Gabriele Abbate  
Associated firms: Canzone, Mediolana

## ALFIERE ESEDRA

Via Borgogna 2, 20122 Milano  
Tel: 791566  
Cable: Cominon, Milano  
General Manager: Peter Keun

## ALLIONE

Via Enrico Toti 4, 20123 Milano  
Tel: 4639920  
General Manager: Abramo Allione

## ARISTON

Piazzetta Pattari 1/3, 20122 Milano  
Tel: 897745  
Cable: Aristonrecords, Milano  
President: Alfredo Rossi  
Manager: Giusta Spotti  
Associated Firms: Accademia, First Music, Formidable, Bussola, MEC, Palace, Pettiroso, Piper Club, Regent, Santa Cecilia, Kassner.

## BIDERI

Via San Pietro a Majella 17, 80138 Napoli  
Tel: 210325  
President: Maria Flavia Bideri  
General Manager: Luciano Villevielle Bideri  
Branch: Via Teulada 52, Roma. Tel: 380700  
Associated firms: Donnarumma, E. Gennarelli, Santa Lucia, Santojanni, Scia.

## BIXIO CEMSA

Via Borgogna 7, 20122 Milano  
Tel: 701107, 701108  
Managing Director: Cesare Andrea Bixio  
General Manager: Pasquale Caliman  
Branch: Via Veneto 108, Roma. Tel: 470764  
Associated firms: Allegro, Grandi Firme Della Canzone.

## CAMPI

Corso Europa 5, 20122 Milano  
Tel: 706915  
General Manager: Theo Treppiedi  
Associated firms: CAM, Fulginea, Sorrisi e Canzoni, Tank, Rome Tree

## CANOPO

Viale Pasteur 70, 00144 Eur Roma  
Tel: 595786  
General Manager: Romano Di Bari

## CARISCH S.p.A.

Via General Fara 39, 20124 Milano  
Tel: 650741  
Manager: Calisto Ravizza

## CIELOVIDEO

Galleria del Corso 2, 20122 Milano  
Tel: 705231  
General Managers: Dante e Virgilio Panzuti

## CURCI

Galleria del Corso 4, 20122 Milano  
Tel: 791440  
President: Giuseppe Gramitto Ricci  
Associated firms: Accordo, Ariete, Cervino, D'Anzi, Dea, Fast, Fortuna, Italcanto, Italian Yank, Izzo, Music Union, Orchestral-music, RTV, Spanka Italiana.

## DOMINGAS

Via S. Paolo 1, 20121 Milano  
Tel: 896770  
General Manager: Christine Leroux

## DURIUM

Via Manzoni 40/42, 20123 Milano  
Tel: 701008  
President: Krikor Mintangian  
Manager: Franco Cassano  
International Dept: Elisabel Mintangian.  
Associated firms: Duomo, Spring, Welbeck

## FP4

Galleria del Corso 2, 20122 Milano  
Tel: 798845  
General Manager: Aldo Pagani

## FONOCINE

Via San Paolo 15, 20121 Milano  
Tel: 874460  
General Manager: Pericle Boschetti

## FRANCIS DAY

Piazza del Liberty 2, 20121 Milano  
Tel: 780036  
Cable: Arpeggio-Milano  
General Manager: Giuseppe Gallazzi  
Associated firms: Cada Editrice Musicale Gustavo Gori, Edizioni Gallazzi, Francis Day & Hunter, Donna, Sea of Tunes, Lawrence Wright.

## GENERAL MUSIC

Viale Liegi 41, 00198 Roma  
Tel: 865307  
General Manager: Enrico De Melis

## GUERRINI

Via delle Erbe 3, 20121 Milano  
Tel: 898635  
President: Gualtiero Guerrini  
General Manager: Maria Luisa Nobile  
Associated firms: Edicom, Eldorado, Rampoldi, San Giusto, Zig Zag

## ITALMUSICA

Corso Genova 22, 20123 Milano  
Tel: 854641  
General Manager: Giovanni Moretto

## LEONARDI

Corso Europa 5, 20122 Milano  
Tel: 702094  
President: Franz Leonardi  
General Manager: Giuseppe Coreca  
Associated firms: Alfa, Cantanapoli, Casiroli, Clan, Elite, Leon, Luisiana, Musicalfilm, Souvenir, Settebello, Dior.

## MAS

Corso di Porta Vercellina 6, 20123 Milano  
Tel: 490171  
General Manager: Pierangelo Codevilla  
International Dept.: Michele Del Vecchio  
Associated firm: Saar.

## MASCOTTE

Galleria del Corso 4, 20122 Milano  
Tel: 793601  
President: Eloisa Spaziani  
General Manager: Eros Sciorilli

## MIMO

Via Degli Scipioni 268/a, 00192 Roma  
Tel: 385430  
General Manager: Franco Migliacci  
Assistant Manager: Giovanna Tentori

## MIURA

Corso Europa 5, 20122 Milano  
Tel: 782296  
Cable: Miurarecords, Milano

## MUSICA E DISCHI

Via Carducci 8, 20123 Milano  
Tel: 870015  
General Manager: Mario De Luigi jr.

## NAZIONALMUSIC

Corso Vittorio Emanuele 30, 20122 Milano  
Tel: 793769  
General Manager: Mario Gili  
Assistant Manager: Aldo Peri  
Associated firms: Chiappo, Ear, Nazionale, Sonofilm.

## NUMERO UNO

Galleria del Corso 2, 20122 Milano  
Tel: 799127  
General Manager: Mariano Rapetti  
Associated firms: Universale, Acqua azzurra

## PICCOLA VELA

Via Enrico De Marinis 4, 80134 Napoli  
Tel: 314140  
General Manager: Felice Genta

## RCA

Via Tiburtina Km. 12, 00131 Roma  
Tel: 416041  
Cable: Radiointer, Roma  
General Manager: Mario Cantini  
Branch: Corso Europa 5, Milano. Tel. 702142  
Associated firms: Aberbach, Progressive, Roosevelt, Carlin, Hill & Range, Lark, Living Music, Pigalie, Spectacular.

## RICORDI

Via Berchet 2, 20121 Milano  
Tel: 898242  
Manager: Federico Monti Arduini  
Associated firms: Edir, Fama, Fonofilm Ricordi, Radio Record Ricordi, Ritmi e Canzoni, Iller, Jubal, Pegaso.

## RIFI MUSIC

Corso Buenos Aires 77, 20124 Milano  
Tel: 273641  
Cable: Rifirecord, Milano  
Managing Director: Giovanbattista Ansoldi  
General Manager: Marinko Rigoldi  
International Dept.: Gianfranco Finamore  
Associated firms: Settebello, Cicogna, Rias.

## RIMI

Galleria del Corso 2, 20122 Milano  
Tel: 793896  
Cable: Mariart, Milano  
General Manager: Marino Marini  
Associated firm: Mini.

## ITALY'S MUSIC PUBLISHERS

### C.A. ROSSI

Via Barletta 11, 20141 Milano  
Tel: 5392392  
General Manager: Carlo Alberto Rossi  
Associated firms: California, Stradivarius, Tre Stelle.

### SCIASCIA

Via Lumiere 2 (Cinelandia), 20093 Cologno Monzese (Milano)  
Tel: 9124691  
General Manager: Armando Sciascia  
Associated firms: Eliseo, International Music of Italy

### SIDET

Piazzetta Pattari 4, 20122 Milano  
Tel: 804818  
General Manager: Emilio Daniele  
International Dept.: Emanuele Daniele  
Branch: Via Teulada 52, Roma  
Associated firms: Bluesky, Daniele, Diamante, Millenote, Radio, Tornado.

### SOUTHERN

Piazzetta del Liberty 2, 20121 Milano  
Tel: 796473  
Cable: Southmusic, Milano  
General Manager: Alberto Carisch  
Associated firms: Applauso, Fortissimo, Fox, Italcarsch, Kramer, Peer Italiana, Sacha Italiana, Settenote

### SUGARMUSIC

Galleria del Corso 4, 20122 Milano  
Tel: 794841  
Cable: Sugarmusic, Milano  
President: Ladislao Sugar  
Vice President: Piero Sugar  
General Manager: Ettore Carrera  
Branch: Via Delle Carrozze 3, Roma. Tel: 681618  
Associated firms: Acuff Rose, Adriatica, Amazonia, Apollo Arion, Araldo, Aromando, Bama, Canzoni Moderne, Cicala, Cobra, Colbi, Di Lazzaro, Falena, Fantasia, Fiera, Flaminia, Frank, Gea, Ivana, Liberty, Mascheroni, Peter Maurice, Melodi, Menestrello, Pickwick, Polaris, Rascel, Resoulte, Screen Gems-Columbia, Sofia, Successo, Supersonic, Suvini Zerbini, Tevere, Tiber, Worldmusic, Annis House, Argo, B&F, Raul Breton, Charles Bruil, Frederick, Genius, Glem, Gopam Ents., Newroad, River, Sparta, Symbol, Taggie, Richmond Organisation, Upam, Vincent, Web IV.

### SENZA FINE

Piazzetta Pattari 2, 20122 Milano  
Tel: 898909  
General Manager: Gino Paoli  
Associated firms: Abigail, Apple, Dratleaf, Saharet.

### VOCE DEL PADRONE

Piazza Cavour 1, 20121 Milano  
Tel: 652577  
Cable: Emigram, Milano  
General Manager: Michel P. Bonnet  
Associated Firm: Belriver

when you need something done  
in Italy

cable CURCIMUSIC

curci music publishers since 1860  
&  
their record company  
carosello cemed  
20122 milan galleria del corso 4  
tel. 794746



# NEW GOALS FOR



THE 1970

## ITALIAN REVIEWERS AWARDS

**LED ZEPPELIN LP**  
"LED ZEPPELIN II"

**GARY BURTON LP**  
"Throb"

**SPECIAL MERIT MENTION**



**WILHELM  
FURTWÄNGLER  
EDWIN FISCHER LP**  
"Brahms -  
Piano Concerto n. 2"

**WITH THESE AWARDS RI-FI HAS ENRICHED ITS SHOWCASE**

1965 AWARD TO MINA LP

1966 AWARD TO THERESA STICH RANDALL LP «Opera Arias»

1966 AWARD TO MINA LP

1967 AWARD TO IVA ZANICCHI LP

1968 AWARD TO HANS SWAROWSKY LP «Peter And The Wolf»

1968 AWARD TO ARETHA FRANKLIN LP

1969 AWARD TO BEDRICH SMETANA «Complete Operas»

**HERE'S WHY THOSE WHO WANT ACTION AND PRESTIGE GO WITH RI-FI**

RI-FI RECORD COMPANY .....ITALY  
RI-FI RECORD COMPANY .....NEW YORK

# ITALY'S RECORD MANUFACTURERS

**ARCOPHON**  
Corso Europa 16, 20122 Milano  
Tel. 790073  
President: Giovan Battista Pirelli  
General Manager: Angelo Efrikian  
Press & Promotion: Carlo Maria Di Lenna  
Domestic labels: Arcophon  
Recording Studio: Corso Europa 16, Milano

Distributed by CAROSELLO/C. E. M. E. D.

**ARISTON RECORDS, I.F.I. Co.**  
Piazzetta Pattari 1/3, 20122 Milano  
Tel. 897745  
Cable: Aristonrecords, Milano  
President: Alfredo Rossi  
General Manager: Giuseppe Tarozzi  
A/R Manager: Gianni Guarneri  
Sales Manager: Piero De Michelis  
International Dept.: Valeria Prini  
Press & Promotion: Guido Ardizzone  
Domestic labels: Ariston, First, Jet  
Foreign labels: Audio Fidelity, Crestwood, President, Primary  
Pressing plant: I. F. I. Co.  
Associated publishing firm: Gruppo Editoriale Ariston  
Manager: Giusta Spotti

**BDS Co. S.r.l.**  
Via Beccaria 5, 20122 Milano  
Tel. 792029  
General Manager: Carlo Carenni  
Press and Promotion: Gian Franco Mulazzani  
Domestic labels: BDS  
Distributed by Ariston  
Associated Publishing Firm: Gruppo Editoriale Bidiess  
Manager: Umberto Belloni

**BELLDISC ITALIANA S.p.A.**  
Via Filippo Turati 28, 20121 Milano  
Tel. 662360, 650677, 65065  
President and General Manager: Antonio Casetta  
A/R Manager: Adriano Solaro  
Press & Promotion: Nicoletta Arcari  
Sales Manager: Enzo Napolitano  
Domestic Labels: Bluebell, Belldisc, Hockey  
Foreign labels: Liberty, Imperial, World Pacific, Blue-note, Hanna Barbera, Europa, Canadian American, Esp Disk, Somerset, Minit, Pacific Jazz  
Pressing Plant: Blueplast, Via Druso 3, Milano  
Associated Publishing Firm: Telstar Edizioni Musicali  
Manager: Arnaldo Morosi

**BENTLER RECORDS**  
Via Erbe 3, 20121 Milano  
Tel. 898635  
President: Quattiero Guerrini  
Domestic label: Bentler  
Associated Publisher: Gruppo Editoriale Guerrini  
Manager: Maria Luisa Nobile

**BLA . . . BLA . . .**  
Galleria del Corso 2, 20122 Milano  
Managing Director: Pino Massara  
International Dept.: Piero Tacchini  
Domestic label: Bla..bla..  
Distributed by: Phonogram  
Associated Publisher: Bla..Bla..  
Manager: Pino Massara

**CAR DISCHI JUKE BOX**  
Via Podgora 12 B, 20122 Milano  
Tel. 780412, 700733  
Managing Director: Giovanni Mongini  
Press & Promotion: Paolo Cattaneo  
Domestic labels: C. A. R., Telerecord

Distributed by: Phonogram  
**CGD COMPAGNIA GENERALE DEL DISCO S.p.A.**  
Corso Europa 5 20122 Milano  
Tel. 794841  
Telegraphic address: Comgedisc, Milano  
President: Ladislao Sugar  
Vice President: Piero Sugar  
Managers: Franco Crepax, Sandro Delor, Giuseppe Giannini  
A/R Manager: Gianfranco Monaldi  
Production Manager: Cesare Brunelli  
Promotion & Publicity: Johnny Porta  
Press Dept.: Marina Testori  
International & Export Dept.: Andrea Bianchi  
Domestic labels: CGD, Derby  
Foreign labels: Reprise, Warner Bros., A&M, Audio Fidelity, Project, Musicor, Festival, Scepter, Crescendo, Puppy  
Pressing plant: Via Moretta 9, Milano (14 presses, 72 workers)  
Recording studio: Galleria del Corso 4, Milano  
Distributed by Messaggerie Musicali  
Associated publishing firm: Sugarmusic  
Manager: Ettore Carrera

**CARISCH S.p.A.**  
Via General Fara 39, 20124 Milano  
Tel. 650741  
President: Aldo Pardi  
Managing Director: Sandro Galli  
A/R Manager: Gino Mazzocchi  
Sales Manager and International Dept.: Giuseppe Cremascoli  
Domestic labels: Carisch  
Associated Publisher: Carisch Edizioni Musicali  
Manager: Callisto Ravizza

**GERMANY: The Past 12 Mos.**  
(Con't. from Page 42)

was give away for the most popular artists in the German program of the first half year of 1969 are: Peter Alexander (Ariola), Freddy (Polydor) and Adamo (Electrola) . . . Electrola took over the distribution of Tamla Motown, until now represented by CBS in Germany.

**CBS ITALIANA S.p.A.**  
Corso Europa 5, 20122 Milano  
Tel. 794841  
Telegraphic Address: Colrec, Milano  
President: Ladislao Sugar  
Vice President: Piero Sugar  
Directors: Franco Crepax, Sandro Delor, Giuseppe Giannini  
A/R Manager: Renato Angiolini  
Production Manager: Cesare Brunelli  
Promotion & Publicity: Gian Borasi  
Press Dept.: Marina Testori  
International & Export Dept.: Andrea Bianchi  
Domestic & foreign labels: CBS, Epic, Major Minor  
Pressing plant: Via Moretto 9, Milano (14 presses, 72 workers)  
Recording studio: Galleria del Corso 4, Milano  
Distributed by Messaggerie Musicali  
Associated publishing firm: April Music  
Manager: Ettore Carrera

**CELLOGRAF SIMP S.p.A.**  
Via Maffeo Maffucci 18, 20158 Milano  
Tel. 3763141  
Telegraphic Address: Cellograf Simp, Milano  
President: Natale Sciascia  
General Manager: Riccardo Rota  
A/R Manager: Gino Mescoli  
Sales Manager: Giovanni Albani  
Domestic labels: Style, Big Ben, Phonocolor, Primavera, Oscar  
Pressing Plant: Via Maffeo Maffucci 18, Milano

**CAROSELLO EDIZIONI MUSICALE E DISCOGRAFICHE—C.E.M.E.D. s.r.l.**  
Galleria del Corso 4, 20122 Milano  
Tel. 794746, 793008  
Cable: Curcimusic, Milano  
President: Giuseppe Gramitto Ricci  
General Manager: Paolo Ruggeri  
International Dept.: Sandra Perlusz  
Domestic labels: Ariete, Carosello, Costanza, Curci, Italian Yank, Mustang  
Foreign labels: CGC Records, Erato, Festival, Page One, 20th Century Fox, United Artists, Viva Records, Buena Vista, Disneyland, Topolino  
Associated Publishing firm: Curci Gruppo Editoriale  
President: Giuseppe Gramitto Ricci

**OCTOBER 1969**

MCA Records was founded in October by the people of the German Miller International with the following personal and repertoire program: Top managers are Harald A. Kirsten and Franz J. Elmendorff; label manager and production chief is Norman Douglas, assistant producer is Peter Mathaus, distribution managers are Hans-Martin Neumann and Uwe

**CINEVOX RECORD**  
Via Borgogna 7, 20122 Milano  
Tel. 701108  
Managing Director: Cesare Andrea Bixio  
General Manager: Pasquale Caliman  
A/R Manager: Carlo Bixio  
Domestic labels: Cinevox, Rang  
Associated Publishing firm: Edizioni Musicali Bixio  
Manager: Pasquale Caliman

**CLAN CELENTANO S.r.l.**  
Corso Europa 7, 20122 Milano  
Tel. 704261  
President: Adriano Celentano  
General Manager: Corrado Pintus  
A/R Manager: Roberto Negri  
International Dept.: Monica Dahl  
Sales Manager: Luciano Degli Innocenti  
Domestic labels: Ciao Ragazzi, Clan, Totem  
Foreign labels: Sonet, Basart  
Associated Publishing firm: Clan S.r.l.  
Management: Gruppo Leonardi

**COMBO RECORDS**  
Via San Martino 5/7, 20122 Milano  
Tel. 848454  
Telegraphic address: Trevisancombo, Milano  
Managers: Roberto Trevisan, Paolo Trevisan  
Domestic labels: Combo, RT Club, Humor

**COMPANY DISCOGRAFICA ITALIANA**  
Via Balilla 36, 20136 Milano  
Tel.: 8472672  
Telegraphic address: Compadisc, Milano  
President: Pierquinto Cariaggi  
Vice President: Alberto Cariaggi  
General Manager: Antonio Cariaggi  
Domestic Labels: CDI, BCD, CDM, Discolino, Discomec  
Foreign labels: Glad and Hamp Records  
Associated Publishing firm: Edizioni Musicali Equipe  
Manager: Pierquinto Cariaggi

**DECCA DISCHI ITALIA S.p.A.**  
Via Brisa 3, 20123 Milano  
Tel. 874048  
Telegraphic address: Deccital, Milano  
President: Sir Edward Lewis  
General Manager: Romano Bacchini  
A/R Manager: Paolo Tosi  
Sales Manager: Luigi Negro  
International Dept.: Paolo Tosi  
Foreign labels: Decca, Argo, Cygnus, Deram, London, Oiseau Lyre, Telefunken, Vega

(Con't. on next page)

Scharfenberg. Radio, TV and press are handled by Klaus-Peter Buttgeit and Ingeborg Eggert. The German MCA started with 40 LP's, besides the low-price label "Coral". . . . The Dutch magazine "Muziek Express" starts a German edition. Editor is Christine Roennfeidt in Den Haag . . . Two of the most important German music publishing houses celebrated their anniversaries: Wiener

(Con't. on Page 47)

**AHEAD**  
That's our slogan  
**PHONOGRAM**  
is the distributor of these  
first class international labels

**PHILIPS**  
**DEUTSCHE GRAMMOPHON**  
**HELIODOR**  
**ARCHIV**  
PRODUKTION

From now on we also distribute:  
**CAR JUKE BOX**  
**TELERECORD**  
**LITTLE RECORDS**  
**BLA BLA**

GENERAL MANAGEMENT  
MILAN - 2 Borgogna str. - tel. 796541  
COMMERCIAL DEPT. FACTORY  
MILAN - 14 Benadir str. - tel. 2826241  
RECORDING STUDIO  
MILAN - 2 Cavour sq. - tel. 790071

# ITALY'S RECORD MANUFACTURERS

**DET DISCOGRAFICA EDITRICE TIRRENA S.p.A.**  
Via Virgilio 8, 00193 Roma  
Tel: 382021  
Cable: Camusic, Roma  
President: Giuseppe Campi  
General Manager: Theo Treppiedi  
Sales Manager: Romeo Frumento  
Domestic labels: DET Records, DET International, Cam, Campi, Tank, Mama  
Associated publishing firm: Gruppo Editoriale Campi  
Manager: Theo Treppiedi

**DISCHI RICORDI S.p.A.**  
Via Berchet 2, 20121 Milano  
Tel: 898242  
Cable: Ricordisc, Milano  
Chairman: Gianni Babini  
Vice President: Eugenio Clausetti  
Managing Director: Guido Rignano  
General Manager: Lucio Salvini  
Sales Manager: Renzo Benini  
A/R Manager (Domestic): Gianni Sanjust  
A/R Manager (International): Vittorio Castelli  
Production Manager: Mimma Gastoni  
Domestic labels: Ricordi International  
Foreign labels: Amadeo pop, Bang, Bell, Amy, Mala, Pye, Vogue, Dot, MGM, Verve, Metro  
Recording Studios: A) Via Dei Cinquecento 1, B) Via Berchet 2  
Associated Publishing Firm: Gruppo Ricordi Musica Leggera  
Manager: Federico Monti Arduini

**DURIUM S.p.A.**  
Via Manzoni 40/42, 20121 Milano  
Tel: 701008  
Telegraphic address: Durium, Milano  
President: Krikor Mintangian  
A/R Managers: Aurelio Airoidi, Felice Piccaredda  
Press & Promotion: Aldo Locatelli  
Sales Manager: Cesare Martinengo  
International Dept.: Elisabel Mintangian  
Domestic labels: Curcus, Durium, Royal, Sprint  
Foreign labels: Argo, Cadet, Chess, Checker, Prestige, Paula  
Pressing plant: Via Trieste, Erba (Como)  
Recording studio: Via Carlo Troja 7, Milan  
Associated publishing firm: Edizioni Durium  
Manager: Franco Cassano

**EMI ITALIANA S.p.A.**  
Piazza Cavour 1, 20121 Milano  
Tel: 652577  
Cable: Emigram, Milano  
President: Francois Minchin  
General Manager: Michel P. Bonnet  
A/R Manager: Giampiero Scussel  
Sales Manager: Carlo Barbareschi  
International Dept.: Sergio Bono  
Promotion: Eraldo De Vita  
Domestic labels: EMI, Columbia, Pathe, Regal, Voce del Padrone, Odeon, Parlophon  
Foreign: Command, Electrola, Apple, Angel, Capitol, ABC  
Pressing plant: Via Bergamo 5, Caronno Pertusella (Varese)  
Associated publishing firm: Edizioni Musicali Voce del Padrone

**EQUIPE DISCHI S.r.l.**  
Via Enrico Toti 4, 20123 Milano  
Tel: 453093  
Managing Director: Abramo Allione  
A/R Manager: Italo Allione  
Domestic label: Eda

**FOLKORE S.r.l.**  
Via Pietro Micca 17, 10121 Torino  
Tel: 518668  
Telegraphic address: Folk Torino  
Managing Director: Carlo Margaria  
A/R Manager: Happy Ruggiero  
Classical production Manager: Edward Neill  
Press & Promotion: Dino Tedesco  
Sales Manager: Nicola Cioffi  
Domestic labels: DKF, Music International Flash, Folklore, Dynamic  
Foreign labels: El Virrey, Chanteclair, Helladisc  
Recording Studio: FF Stereo Studio, Via Ventimiglia 194, Torino

**FONIT CETRA S.p.A.**  
Via Bertola 34, 10122 Torino  
Tel: 5753  
Cable: Fonitcetra, Torino  
President: Renato Zaccone  
General Secretary: Renato Poli  
A/R Manager: Mario Zanoletti  
Sales Manager: Luigi Arduino  
International Dept: Maurizio Golla  
Press & promotion: Rosita Robba  
Domestic labels: Cricket, Excelsius, Fonit, Cetra  
Foreign labels: Ariola, Hachette, Eurodisc, International Hi Fi, Musicdisc, America, Fantasy  
Pressing plant: Via Meda 45, Milano  
Recording Studios: A) Via Bertola 34, Torino — B) Via Meda 45, Milano — C) Largo Argentina 3, Roma  
Associated publishing firm: Edizioni Musicali Usignolo  
General Manager: Wilma Battigelli

**KING S.p.A.**  
Via Egiziaca a Pizzo Falcone 41/a, Napoli  
Tel: 237226, 237413  
Managing Director: Maria Rosaria Matone Fierro  
A/B Managers: Aurelio Fierro, Gianni Aterrano  
Production Manager: Tina Buono  
Press & Publicity: Alfredo Saitto  
International Dept: Costantino Paolini  
Sales Manager: Antonio Polce  
Domestic labels: King Universal, Star Records, Capri Records  
Pressing plant: Via Egiziaca a Pizzo Falcone 41/a, Napoli  
Associated Publishing firm: Indios Edizioni Musicali  
Manager: Aurelio Fierro

**ITALMUSICA**  
Corso Genova 22, 20123 Milano  
Tel: 854641  
President: Marna Vescovi Pigni  
A/R Manager Giovanni Moretto  
International Dept: Lanfranco Pigni  
Domestic labels: Silver Records, Sir, IPM, Pig  
Pressing plant: Ripa Ticinese 65, Milano  
Associated publishing firm: Edizioni Italmusica  
Manager: Giovanni Moretto

**IT DISCHI ITALIA EDIZIONI**  
Via Cagliari, 13, Roma  
Tel: 864643  
General Manager: Enzo Micocci

**ITALDISC/DUCALE/MCA**  
Galleria del Corso 4, 10122 Milano  
General Manager: Davide Matalon  
Pressing plant: Brebbia (Varese)  
Domestic labels: Ducale, Italdisc, Meazzi, Hollywood  
Distributed by C. E. M. E. D.  
Associated publishing firm: Edizioni Ducale  
Manager: Davide Matalon

## GERMANY: The Past 12 Months

(Con't. from Page 46)  
Boheme, 50 years and Ufaton, 40 years . . .

### NOVEMBER 1969

German record award 1969 was donated by the magazine "Fono Forum". It is annually found out in autumn in cooperation with "Hi-Fi Stereo" and "Musica" by an independent jury. Records, given in for this competition, had to be released in West Germany during the last 18 months. About 400 records and productions were given in. 35 records, from Mozart to the Beatles, were distinguished. 7 prizes fell to Electrola's share, 6 for Deutsche Grammophon, 4 for Philips and Teldec, 2 for Ariola, CBS, Wergo and harmonia mundi,

and even one for Cantate and Baerenreiter. Two prizes fell to the English singer Janet Baker's share, for two Italian cantates by Haendel as well as Mahler's "Lieder eines fahrenden Gesellen" and "Kindertotenlieder" (both Electrola) . . . New chief of CBS records is Rudolf Wolpert. He is the follower of Bernhard Mikulski, who founded the CBS Schallplatten GmbH in Germany in 1963 and made it to one of the most important record firms in Germany . . . The biggest European magazine, the German TV magazine "HOER ZU" (weekly circulation about 4 millions), started a experiment-LP-series named "Black Label." The repertoire based on absolutely modernity in the classical and pop sector and on rarities. "HOER ZU" publishes since years in co-operation with leading German record firms an own LP label.

### DECEMBER 1969

Erich Offierowski left his job as leader of pop production with Electrola in Cologne and will work with them as an independent producer . . . Freddy Quinn, one of the most famous hit singers in Germany, got his 12th golden disk from Polydor for his LP "Weihnachten auf hoher See" . . . Teldec offers a new label Resono, which presents German film and tv stars . . . Producer Larry Page founded a new label "Penny Farthing," which is distributed by Phonogram . . . The managing directors of Liberty and Ariola signed a sales contract for the Sunset-Reperoire. Ariola took over the distribu-

tion of Sunset in Germany retail trade without all warehouses, supermarkets and mail order houses. Further, Liberty offers the Sunset repertoire to the German record wholesale, the department-stores, supermarkets and mail order houses over their own distributions organization . . .

**JANUARY 1970**  
In Cannes the MIDEM Pop-Music took place and was a great success for the German trade. More than 22 German firms participated and about 120 publishers, record men, journalists, radio- and tv-people attended. But in contrast to other countries only three German authors came to MIDEM: Bert Kaempfer, Michael (Con't. on Page 48)

studio usellini



the sound of success is on



DISTRIB. MESSAGGERIE MUSICALI - MILANO - ROMA

# ITALY'S RECORD MANUFACTURERS

(Con't. from Page 45)

**MIURA RECORDS S.p.A.**  
Corso Europa 5, 20122 Milano  
Tel. 782296  
Cable: Miurarecords, Milano  
President: Lorenzo Sampietro  
Sales Manager: Giorgio Termignoni  
Domestic labels: Miura, Brio  
Associated publishing firm: Gruppo editoriale Miura

**PHONOGRAM S.p.A.**  
Via Borgogna 2, 20122 Milano  
Tel. 796541  
Cable: Comingam, Milano  
Managing Director: Alain Trossat  
Assistant to the Managing Director: Roberto Galanti  
A/R Manager: Marcello Minerbi  
Promotion Manager: Maso Biggiero  
Press: Dario Pogliani  
Sales Manager: Franco Paradiso  
Domestic label: Melodicon, Philips, Polydor  
Foreign labels: Archiv, Deutsche Grammophon, Fon-  
tana, Heliodor, Mercury, Philips, Polydor  
Pressing plant: Via Benadir 14, Milano  
Recording studio: Piazza Cavour 2, Milano  
Associated publishing firm: Gruppo editoriale Alfiere/  
Esedra

**PDU PLATTENDURCHARBEITUNG ULTRAPHONE AG.**  
Schaan (Liechtenstein)  
General Management:  
Via Pioda 9, Lugano (Switzerland)  
Tel. 37666, 29142, 32213  
Telegraphic address: FIDAM PDU, Lugano  
President: Giangiorgio Spiess  
Managing Director: Alfred Hasler  
Public Relations: Giacomo Mazzini  
Assistant Manager: Milena Bobbia  
Press & Promotion: Luciano Tallarini  
Sales Manager: Renzo Gramagna  
A/R Manager: Augusto Martelli  
Domestic labels: PDU, SUN  
Distributed by: Durium  
Recording Studio: "La Basilica," Via Sant'Eufemia 25,  
Milano  
Associated firm: PDU ITALIANA S.p.A.  
Via Senato 12, 20121 Milano  
Tel. 793459, 793381, 793001  
President: Giangiorgio Spiess  
Managing Director: Riccardo Bonadeo  
Associated Publishing firm: Edizioni Musicali PDU  
Manager: Vittorio Buffoli

**RCA S.p.A.**  
Via Tiburtina km 12, 00131 Roma  
Tel. 416041  
Cable: Radiointer, Roma  
President: Enrico Galeazzi  
Managing Director: Giuseppe Ornato  
Assistant Manager: Ennio Melis  
International Dept.: Francesco Fanti  
Press & Promotion: Nicola Onorati  
Sales Manager: Luciano Bernacchi  
Domestic labels: Arc, RCA Italiana, Talent  
Foreign labels: Ducretet Thompson, RCA Custom,  
RCA Victor, RCA Victrola, Vik, Tamla Motown, IL,  
RGE  
Pressing plant: Via Tiburtina km 12, Roma  
Recording studio: Via Tiburtina km 12, Roma

Associated publishing firm: Edizioni musicali RCA  
Manager: Mario Cantini

**RI.FI RECORDS Co. S.p.A.**  
Corso Buenos Aires 77, 20124 Milano  
Tel. 273641  
Telegraphic address: Rifirecord, Milano  
Chairman of Board: Giampiero Rossi  
Managing Director: Gionvanbattista Ansoldi  
A/R Director: Antonio Ansoldi  
Production Manager: Ezio Leoni  
Press & Promotion: Wladimiro Albera  
Sales Manager: Piero La Falce  
International Dept.: Giuseppe Velona  
Domestic labels: Antoniano, Pubblidisco, Primary, Rifi,  
Variety  
Foreign labels: Atlantic, Atco, Jayjee, Jubilee, Laurie,  
Monument, Reditune, Supraphon, Turnabout, Vox,  
Westminster  
Pressing and printing plant: Via Vespolate 22, Con-  
fianza (Milano)  
Recording studios: Play-Co, Via Stromboli 18, Milano  
Associated publishing firms: Ri.Fi Music, Settebello,  
Cicogna, RIAS  
Manager: Marinko Rigoldi  
International Dept.: Gianfranco Finamore

**NUMERO UNO**  
Galleria del Corso 2, 20122 Milano  
Tel. 799127  
President: Mariano Rapetti  
Managing Director: Alessandro Colombini  
A/R: Giulio Rapetti  
Press & Promotion: Mara Maionchi

**GERMANY: The Past 12 Mos.**  
(Con't. from Page 47)

Holm and Georg Moslehner. The 14 years old German star Heintje received from his record firm a platinum disk for more than 2 million sold of his LP "Heintje" . . . The Deutsche Grammophon Gesellschaft founded the new pop-label "Kuck-uck" with seat in Munich. Creator and chief of this independent production is Eckart Rahn . . . Ariola-Eurodisc opened a Benelux agency with offices in Haarlem, Holland . . . Cornet-records (owners are Heinz Gietz and Guenter Ilgner) got a new studio in: 5 Cologne-Junkersdorf, Aachener Str. 12 . . . In 1969 as a statistic shows, only 246 of the 2300 records (10.07%) released reached the top 40 positions of the hit-parade. 133 titles (54.07%) of the 246 were composed by English and American authors, 85 titles (34.55%) by German authors and 28 (11.38%) by foreign authors.

International Dept.: Franco Daldello  
Distributed by: RCA S.p.A.

**SAAR S.r.l.**  
Viale di Porta Vercellina 14, 20123 Milano  
Tel. 4696251  
Cable: Saar, Milano  
President: Walter Gurtler  
Sales Manager: Sergio Balloni  
Domestic labels: Jolly, Stella, Music, Jocker  
Foreign labels: Contact, Roulette, Zafiro

**SAINT MARTIN RECORDS s.a.s.**  
Via Porro Lambertenghi 34, 20159 Milano  
Tel. 6884434  
President: Gino Caselli  
General Manager: Walter Del Comune  
Press & Promotion: Mario Guarino  
Domestic labels: Saint Martin, King George

**SIF, SOCIETA' ITALIANA FONOGRAFICA S.p.A.**  
Via Crivelli 20, 20122 Milano  
Tel. 581402  
President: Hubert Ballay  
Managing Director: Giampiero Simontacchi  
Production Manager: Bruno Pallesi  
International Dept.: Franco Simontacchi  
Press & Promotion: Fioranna Panetta, Mirca Ghidotti  
Sales Manager: Amleto Silvestri  
Domestic labels: SIF, Rare  
Foreign labels: Barclay, Riviera, Disques Fleche

**TIFFANY RECORDS S.r.l.**  
Galleria del Corso 2, 20122 Milano  
Tel. 781694  
Cable: Mariart, Milano  
General Manager: Marino Marini  
A/R Manager: Carlo Marini  
Domestic labels: Tiffany, Populart  
Distributed by: Durium  
Associated publishing firm: Edizioni Musicali Rimi  
Manager: Marino Marini

**VEDETTE RECORDS EDIZIONI FONOGRAFICHE S.r.l.**  
Via Lumiere 2 (Cinelandia) 20093 Cologno Monzese  
(Milano)  
Tel. 9124691  
Managing Director: Armando Sciascia  
Pop A/R Manager: Francesco Anselmo  
Classic A/R Manager: Aliko Andris  
Press & Promotion: Antonio Pasqui  
Sales Manager: Sergio Sciascia  
International Dept.: Aliko Andris  
Domestic labels: Corsair, Tempo, Vedette  
Foreign labels: Elektra, Barenreiter Musicaphon,  
Ember, Lyr, Nonesuch, Scala, Rosenbit, Counter-  
point, Hi Fi, Period, Starday  
Recording studio: Sound Studio Vedette, Via Lumiere  
4, Cologno Monzese (Milano)  
Associated publishing firm: Edizioni musicali Sciascia  
Manager: Armando Sciascia

**WEST RECORD**  
Piazzetta Pattari 2, 20122 Milano  
Tel. 873325  
General Manager: Mario Ratti  
Domestic label: West Record  
Distributed by: Vedette  
Associated publishing firm: Edizioni Giada

ieu, Dusty Springfield and Aretha Franklin; Tom Jones, Adamo and Donovan. The most liked groups were the 5th Dimension, The Beatles and Creedence Clearwater Revival. In Germany Mary Hopkins, Lulu and Paola; Barry Ryan, Tommy Roe and Peter Sarstedt have been the favorites among the international young talents. The most popular German orchestras are James Last, Max Greger and Bert Kaempfert, the foreign ones are Herb Alpert, Ray Conniff and Mantovani . . . Radio Luxemburg, which is weekly heard by 14.49 million fans, or 31.3% of the grown up population over 14 years in Germany, lengthen its German station time and daily broadcast . . . James Last has been the most successful star in pop music trade in 1969 with 8 LP's on the hit parade . . . United Artists Musik GmbH, which had been looked after

(con't on next page)

studio usellini



driving successes

are on



DISTRIB. MESSAGGERIE MUSICALI - MILANO - ROMA

# Italian Festivals: A NEW APPROACH

by Giuseppe Velona, Manager of RiFi's Int'l Dept.

The proliferation of contests and festivals telecast has been one of the most bewildering phenomena in the Italian world of music in the 60's. From the festival of San Remo, which has been, for many years, the prince of festivals on a European scale, we have landed on a myriad of festivals, some of which have lasted the flicker of an eyelash, while others are now established. What have been the negative ends of this proliferation?

First of all, the fact that, according to a general belief, such festivals have to have losers and winners. This inevitably exposes most of the participant artists to the risk of blowing their chances, if they turn out to be losers. As a consequence, the anxiety of offering a product that can be accepted by random juries causes record companies to present songs penned according to a formula of convenience, but that are miles away from the musical reality of the moment.

Secondly, such large TV exposure limits when it doesn't even cancel, the space would be available for TV shows of different kinds that could be produced in a far better way than a festival.

But the most dangerous side of this situation is the utmost difficulty to promote foreign artists. Forced to face such a situation, Italian record companies have no alternative: either they present a foreign artist at a festival, risking his career (in Italy) if, by chance, the artist is not among the winners (and, incidentally, not all the festivals admit foreign artists), or they have to hope for good luck. And nobody forgets that, today, to take part in a festival is very expensive, as

the organizers — taking advantage of the TV presence — not only refrain from paying any fee, but exact exorbitant admission and participation charges.

Naturally, also our company has gone through such experiences, has taken its own risks, by bringing to Italy foreign artists (together with their own bands and equipment) and by bearing substantial expenses. We have been lucky and, just from festivals, have drawn (for our Italian and foreign artists) excellent results, being twice the winners of the San Remo Festival, always placing our entries into the finals, winning a "Cantagiro," winning a Venice Festival.

Apparently, we shouldn't have any reason to complain about festivals. However, it was just RiFi, on the initiative of its managing director Giovanni Battista Ansoldi, that has presented to the Italian Association of the Phonographic Industry (AFI) a motion for the retrenchment of contests and festivals, for a more direct cooperation between AFI and the Italian Radio-TV, with the purpose of reorganizing on a new basis the promotional media that TV makes available, with the purpose of offering a fresh and vital product, free from the fear of votes, juries, finals, etc., without risks, without asking Italian record companies to be brave pioneers.

Renouncing a selfish defense of our position as well as of our direct interest, we believe we have developed an action of common benefit for all the Italian Industry, for the artists (domestic or aliens), for catalogues we represent in our country.

## GERMANY: The Past 12 Mos.

(Con't. from Page 48)

by the Frankfurter music publishers Melodie der Welt, is on its own in Munich. The new director is Siegfried E. Loch, previously with Metric Music in Munich. Ariola/Eurodisc took over the distribution of the CSSR-label Supraphon for West Germany. Up to now it has been done by Deutsche Grammophon.

## FEBRUARY 1970

The winners of the "Loewe (lion)-award" of the hit parade of Radio Luxembourg are 1. Ricky Shayne, 2. Andy Kim and Michael Holm, 3. The Equals . . . In future, the international pop interests of the Deutsche Grammophon Gesellschaft will be co-ordinated through the Deutsche Grammophon Ltd. London. Coincidentally, D. Grammophon founded the Polydor Music A.S. Copenhagen, for representation and distribution . . . The "Bundesverband der Phonographischen Wirtschaft" e.V., Hamburg, which represented the interests of all important record firms in Germany and to which record-publishers and record-clubs belong, will intensify its public relations work. Therefore the "Bundesverband" gave a respective order to the UPS-agency for institutional work, Uecker & Co., Hamburg. UPS is obliged to take measures of the institutional publicity and public relations work for the medium records . . . Gerry Hall, director of European Ampex-Stereo Tapes in London, communicated that Michael Lendvai became manager for Ampex tapes in Germany, Austria and Switzerland . . .

## MARCH 1970

The Hamburg magazine and publishing concern Gruner & Jahr started its own record label "Maritim". An exclusive distribution contract was signed with Ariola/Eurodisc. The aim of "Maritim" is to organize a standard discography of quality LP's on the low price sector . . . CBS will put out two new US labels

on the German market: Arhoolie and Fillmore . . . The German Vogue, Cologne, started a MusiCassetts program together with the French Vogue and PYE, London . . . The English hit composers, Bill Martin and Phil Coulter, signed a contract with the music publisher Hans R. Beierlein of Edition Montana, to compose songs for German hit stars. Aim and purpose of this co-operation is to give five German singers the chance to be successful in other countries.

## APRIL 1970

In this month George Albert, publisher and president of Cash Box came to Germany for an information visit and to introduce his new international director Carlo Nistri to the German branch. They had an exchange of ideas with the gentlemen of all leading firms. Cash Box made sure that it will strengthened in the future their world wide representation and for the German record trade . . . The Deutsche Grammophon Gesellschaft concluded with the Italian firm Ricordi a repertoire - taking over-contract which provides that Grammophon be permitted to produce the Recordi exclusive artists in German language . . . The exclusive contract between Bell Records and CBS for Germany, Austria and Switzerland has been renewed by Larry Uttal, president of Bell Records, and CBS-manager Rudolf Wolpert . . . Katja Ebstein reached the third place of the "Grand Prix Eurovision de la Chanson" in Amsterdam with the title "Wunder gibt es immer wieder," composed by Christian Bruhn, texted by Guenther Loose. This single is published by Liberty/US. For the German market the Irish Conqueror title "All Kinds Of Everything" by Dana was released by Teldec. Edition Montana of Hans R. Beierlein secured for themselves the copyright for Germany . . . The departments MCA plant management, press- and promotion; department for MCA and Miller International move to Hamburg. The firm S & Record Service, Studach & Sollberger had taken over for the Swiss the general agency for this house . . .

(Con't. on Page 63)

**Edizioni Musicali S.r.l.**

**IF YOU ARE LOOKING FOR AN ITALIAN PUBLISHER WITH INTERNATIONAL MIND WE ARE YOUR PARTNER**

**CHRISTINE LEROUX**

**AFTER LES COPAINS AND E.L. & CHRIS**

**HAS ESTABLISHED HER OWN PUBLISHING**

# JAPAN: The Past 12 Months

## OUTPUT OF RECORDS:

The total output of records for the period, January through December 1969 has reached 130,000,000 copies and 60,400,000,000 in value, showing the increase of 23% from previous year. However, output of 45 r.p.m. records remained about the same as the previous year . . . output of 12 inch LP has shown a sudden increase to keep well above the percentage increase of the unit output and sales. It can be said that our record industry has entered on it's new phase.

Monthly output of discs in 1969 has shown the same tendency as in previous years. That is, steady increase in the first part of the year and a tremendous increase during October to December. The share percentage of increase in our market of various discs, 45 r.p.m., 10 inch LP, and 12 inch LP's has shown a drastic changes in 1969. 45 r.p.m. has shown increase of only 3% and value and 9% in value of 21,000,000' 10 inch LP has shown a sudden increase of 300% in 1968 volume and 200% increase in value due to releases of 10 inch LPs by the various book publishers. However, it has shown a decrease of 31% in volume and 45% in value for the year 1969 as compare with the year 1968. The year 1969 has brought phenomenal increase in the output and sales of 12 inch LPs, showing the increase of 44% in volume and 41% in value as compared with the previous year. This remarkable increases in the sales of 12 inch LPs has brought on new demension to our market.

Another important phenomenal changes in the picture of our market is the rapid increase in the output and sales of local products (Japanese originated records). It has shown a steady and noticeable increase in sales since 1966 and have overcome the output and sales of the discs from imported matrices, since then this trend in local products have increased to an tremendous proportion. Today,

the ratio of production and sales of local (Japanese) products and imported matrices is about 10 to 2 and shows a steady widening of the ratio gaps. However, in the field of classical music, imported matrices is still far ahead of Japanese classical release. It is interesting to note that foreign of 19%. Number of 12 inch LPs released in 1969 have increased from 1374 in 1968 to 1638 in 1969 as compared with decrease of 40% on Japanese classical from 203 to 302 albums.

## OUTPUT OF RECORDED TAPES; CARTRIDGES, CASSETTES:

Recorded tape field have come into it's own in the past year after it was introduced into our market in 1966. It has kept abreast with the development and output of automobile industry, rise of standard of living, completion of many through ways and highways. The output of recorded tapes in 1969 has shown rapid increase and amounts to 20% of the entire sales of recorded music output.

Cartridge Tapes occupys about 90% of the total output and sales. With increased inroad into recorded tape field by the major electric companies, the future of the recorded tapes is very bright and are attracting strong attention.

## REVISION OF COPYRIGHT LAW:

A bill of new copyright law which the Government introduced in the Diet this year has passed Houses of Representatives and Councilors in April 1969, and new copyright law will be effective from January 1971. Old copyright law was promulgated in 1890 when Japan became a member of the Berne Convention. Thereafter, partial amendment of the law had been made several times, the old state of the provision is not applicable to the present situation for the practical use of the works to be protected in Japan. Accordingly, the old copyright law was

required to be amended in order to meet the requirement of the present times to provide more protection for copyrights. In 1962, the Government submitted the revision of the old copyright law to the Copyright Revision Committee for consideration for through study of the law for revision, and for the possible revision of the Intermediate Service Law concerning Copyrights which is closely related with the practical use of the Copyright Law.

Based on the reports from the Committee in May and October of 1966, the Government have been trying to take up the registration of the Law, concerning "Copyrights", and another "Intermediate Service concerning Copyrights", and both bills were expected to become effective from 1968 upon the approval of the Diet. However, because of the fact that the revision should be a sweeping all-out one and additional regulation of Neighbouring Rights should be newly regulated, it took considerable time in the drafting stage of the Law. Under the above mentioned circumstances, the Government gave up the submission of the bill to the Diet in 1966.

In 1969, the Government introduced the bill for new copyrights law into the Diet. But, it had been shelved at the session which had to take up the problems of Okinawa, Vietnam and other important affair prior to the deliberation of the bill, and carried over to the session of the Diet in 1970. Mainpoints of revisions are;

Although the original bill called for payment of royalties for every commercial use of recorded music by all establishment, it was modified due to the strong pressure from the users as an incidental condition that the licensor must take a cautious attitude for the collection of the fees by mutual understanding between licensor and users. It is said that copyrights royalties will be exempted from the use of recorded music in ordinary coffee shops, bars, stores and other

business establishments, but special shops and night clubs designed for the entertainment for customers to listen to music are not exempted.

Considering the length of copyright protection in the world, postmortem duration of copyrights for protection was extended to 50 years from 38 years in response to the long-standing demand from the authors, writers, composers, and copyright owners as well as to the Government requirement to bring the copyright system up to international level.

As Neighboring Rights, the rights of performing artists, record manufacturers and broadcasting stations are strengthened, and these rights are preserved separately.

## POPULAR MUSIC:

In 1969, popular music has made inroads extensively into the public through the medium of Radio and Tv. Meiji Confectionery Co. took popularity vote to select the best 30 songs for "Young Japanese Popular Song Artists Festival" which was held at EXPO in May of 1970. They introduced the artists and their hits on a half hour Radio program every weekdays since October of 1969. They also invited the Osmond Brothers to make personal appearance at the Budohkan in December. On the other hand, Nippon Gakki Co. held "Popular Music Festival" at the national park called Nemuno Sato in Shima Peninsula in July 1969.

The popularity vote for "Young Japanese Popular Song Artists Festival" was taken during the 6 months period by the 3 radio stations hook up with TBS, NIPPON and BUNKA with the vote from several million Japanese Popular Song fans. This event was the largest scaled vote getting campaign for Japanese Popular Songs. "Osmond Brothers Concert" drew 15,000 fans at Budohkan, and it

(Con't. on Page 52)

All-embracing Music Publisher Group

with proud tradition in

# JAPAN

✦ Music Magazines ✦ Music Books ✦ Music Texts ✦ Music Copyrights ✦

Well-established publisher

## ONGAKU-NO-TOMO-SHA

President: SANSAKU MEGURO

And the active affiliates

Music Publisher

## SUISEI-SHA

Managing Director: MICHIKO SEKINE

## TOA MUSIC CO.

President: SUNAO ASAKA

Address: 6-30 Kagurazaka, Shinjuku-ku, Tokyo. Phone: 268-6151 ~ 5

# Top entertaining organization in Japan



SHINICHI MORI



MICHIYO AZUSA



CHIYO OKUMURA



MARI HENMI



AKIRA FUSE



THE TIGERS



THE PEANUTS



MIE NAKAO



THE COOL FIVE

## WATANABE

WATANABE PRODUCTION CO., LTD.

President: SHIN WATANABE

WATANABE MUSIC PUBLISHING CORP.

President: MISA WATANABE

#4 1-CHOME YURAKUCHO CHIYODA-KU, TOKYO, JAPAN

TEL.: 502-0541 CABLE PROWATANABE

As Known

# TOHO MOVIE

Now Started New Brand

RECORD LINE Called

## TOHO RECORDS



For the best in result:  
Contact us for distribution:

### TOHO RECORDS CO., LTD.

Head Office:

14-1-Chome, Yuraku-Cho, Chiyoda-Ku, Tokyo, Japan  
Telephone: 591-1211

Branch Office:

Toho International, Inc.  
1501 Broadway-New York, New York-10036  
Telephone: LO-3-5258  
834 South La Brea Ave. Los Angeles, California-90036  
Telephone: 933-5877  
% Representant De Towa Co., Ltd.  
Queen Elizabeth Hotel 43, Av. Pierre-Ler-De-Serbie,  
Paris 8e Telephone: Ba1-2293  
Mr. S. Oeda  
Via Reno 4, 00198 Rome, Italy  
Telephone: 850617

# JAPAN'S RECORD MANUFACTURERS

**CBS/SONY RECORDS INC.**  
7-17-3 Roppongi, Minato-ku, Tokyo, Japan  
President: Norio Ohga  
Telephone: 585-0411  
Label: CBS/Sony

**KING RECORD CO., LTD.**  
13-12-2 Otowa, Bunkyo-ku, Tokyo, Japan  
President: Kazumitsu Machijiri  
Telephone: 941-3111  
Label: London, Telefunken, Argo, Deram, A&M, ABC  
Paramount, Command, Impulse, Westminster, Blues  
Way, Project Three, United Artists, Solid State, Van-  
guard, Contemporary, Good Time Jazz, Barclay, Seven  
Seas, King

**MINORUPHONE CO., LTD.**  
Dai-2 Taihei Bldg.  
2-2-1 Iwamoto-cho, Chiyoda-ku, Tokyo, Japan  
President: Yasuyoshi Tokuma  
Telephone: 862-1381  
Label: Minoruphone

**NIPPON COLUMBIA CO., LTD.**  
4-14-4 Akasaka, Minato-ku, Tokyo, Japan  
President: Joji Kanzaki  
Telephone: 584-8111  
Label: Disney Land, Time, Mainstream, Barenreiter,  
Melodia, Muza, Palette, Hispavox, Erato, Amadeo,  
Sutraphon, Major Minor, Budget Sounds, Buddah,  
Pye, MPS, Audio Fidelity, Denon, Nippon Columbia

**NIPPON CROWN CO., LTD.**  
Shinwa Bldg.  
8-10-2 Alasaka, Minato-ku, Tokyo, Japan  
President: Kazuhisa Arita  
Telephone: 582-4741  
Label: Crown

**NIPPON GRAMMOPHON CO., LTD.**  
4-8-1 Ohhashi, Meguro-ku, Tokyo, Japan  
President: Shinken Izawa  
Telephone: 462-5131  
Label: Archiv, Polydor, Riverside, Verve, Heliodor, Ka-  
russell, MGM, Atlantic, Stax, Kinder, Grammophon

**K. K. SHINSEKAI RECORD**  
Saiwai Bldg. 2nd Floor 16-go,  
1-3-1 Uchisaiwai-cho, Chiyoda-ku, Tokyo, Japan  
President: Kei Hoashi  
Telephone: 591-0969  
Label: Shinsekai Record

**TEICHIKU RECORDS CO., LTD.**  
Teichiku-Kaikan,  
1-2 Nishi-Shinbashi, Minato-ku, Tokyo, Japan  
President: Toyoji Nanko  
Telephone: 502-6651  
Label: Union, Monument, Scepter, Teichiku

**TOSHIBA MUSICAL INDUSTRIES LTD.**  
17-2-2 Akasaka, Minato-ku, Tokyo, Japan  
President: Yoosuke Kan  
Telephone: 585-1111  
Label: Angel, Odeon, Capitol, Stateside, Apple, Liberty,  
Blue Note, Warner Brothers, Kapp, Immediate, Ex-  
press, Toshiba

**VICTOR COMPANY OF JAPAN LTD.**  
1-1-4 Nihonbashi-Honcho, Chuo-ku, Tokyo, Japan  
President: Hitoshi Momose  
Telephone: 241-7811  
Label: RCA Victor, Philips, Mercury, Fontana, Roulette,  
Dot, Reprise, Vogue, 20th Century, Globe, Pres-  
tige, Tamla Motown, Elektra, Green City, Ranwood,  
Sounds of Hawaii, Paramount, ESP Disk, Milestone,  
Vee Jay, Shinsekai, Transatlantic, Chess, Victor

### JAPAN: The Past 12 Mos.

(Con't. from Page 50)

has come to light that confectionery company not related to music business such as booking agents, and production companies, has held such music festival and concert. "Popular Music Festival" at Nemuno Sato was held under similar conditions as San Remo Festival, and many leading popular artists, composers, and authors have participated.

A wide variety of Japanese Popular Songs has been found among the best hits of 1969, from "Blue Light Yokohama" sung by Ayumi Ishida, "Hana To Choh" by Shinichi Mori, "Kin-jirareta Koi" by Ryoko Moriyama, to "Ikebukuro no Yoru" by Mina Aoe. One of peculiarities of 1969 hit songs was rapid climb on the hit chart. There were many hit records sold over half million copies within one

month after their release. Among the hits such as Ryoko Moriyama's "Kin-jirareta Koi," Shinichi Mori's "Hana to Choh," "Minatomachi Boues," Ayumi Ishida's "Blue Light Yokohama," Chiyo Okumura's "Koi no Dorei," Pinky & Killers' "Hoshizora no Romance," Naomi Sagara's "Iijyanaino Shiawase Naraba" and Mieko Hirota's "Ningyo no Ie," were recorded by female singers except for Shinichi Mori, and decline of male singers and veteran singers such as Frank Nagai, Kohichi Miura, Hachiroh Kasuga was called public attention.

The best sellers recordings by the new artists were such as Hide & Rosanna's "Ai no Kiseki," Mariko An's "Kanashimi wa Kakeashide Yatte-kuru," Kaoru Chiga's "Mayonaka no Guitar," Saori Yuki's "Yoake no Scat." Other recordings reaching

(Con't. on Page 54)

# JAPAN C.A.M.CO., LTD

President: NAGAMASA KAWAKITA

ONLY PUBLISHER IN JAPAN

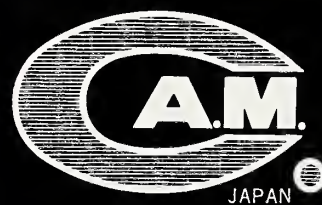

COMBINING  
MOTION PICTURE  
AND MUSIC

★New Sound Track Album  
GOYOKIN  
THE NIGHT OF THE SEAGULL  
SUN ABOVE DEATH BELOW  
LATITUDE ZERO  
PRODUCED BY TOHO

SAFARI 5000  
ISHIHARA PRODUCTION

★New Hit Album  
MORE (MONDO CANE)  
L'eclisse  
GO-KART TWIST

ADDRESS: PLAYGUIDE BLDG., NO. 6-4-2-CHOME  
GINZA CHUO-KU, TOKYO, JAPAN  
TEL: TOKYO (562) 0111  
OVERSEAS OFFICES: PARIS, ROME, NEW YORK.



**Most Progressive Record & Recorded Tape Maker in Japan**



# KING RECORDS

**Distribute Following World-Famous Labels**

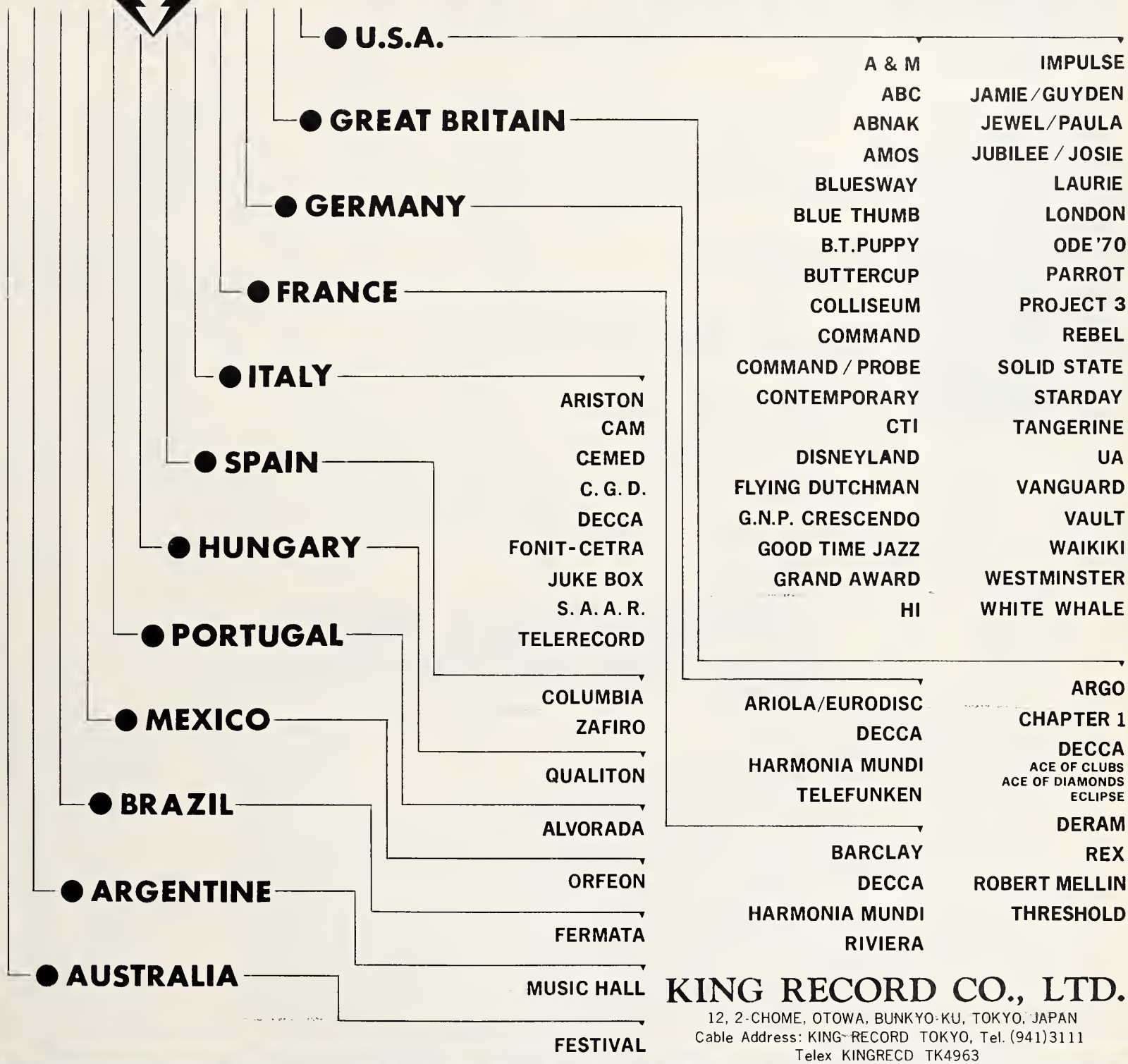

**KING RECORD CO., LTD.**

12, 2-CHOME, OTOWA, BUNKYO-KU, TOKYO, JAPAN  
 Cable Address: KING-RECORD TOKYO, Tel. (941)3111  
 Telex KINGRECD TK4963

Gentlemen!

With Regard To JAPAN, We Trust Our Rights To



MUSIC

# SEVEN SEAS MUSIC Co., Ltd.

**Ampar Group , Fermata do Brasil , Neil & Skyview.**

# SHURE

## Microphones

### UNISPHERE I

#### MODELS 565, 565S&565GOLD

Now! You can get all the superb feedback-control and uniform cardioid pickup pattern features that have made the Unidyne family of microphones world-renowned for solving difficult public-address problems-with the added problem-solving ability achieved through special filter assemblies that effectively control explosive breath sounds ("POP") and minimize wind noise in outdoor locations (eliminating the need for windscreens). The Unisphere I provides excellent reproduction of voice and music-can be effectively used outdoors and indoors.



Model 565S      Model 565/565GOLD

# SHURE VOCAL MASTER

**Built for  
Today's  
Vocal Music!!**

SHURE BROTHERS INC.  
222 Hartrey Ave., Evanston, Illinois 60204

BALCOM TRADING CO., INC.

C. P. O. BOX 176  
FUKOKU BUILDING  
NO. 2, 2-CHOME, UCHISAIWAI-CHO,  
CHIYODA-KU, TOKYO  
JAPAN

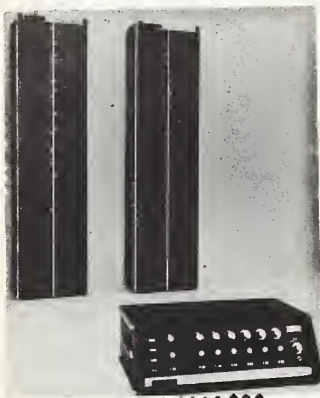

Model VA302



# JAPAN'S RECORD PRODUCERS

ART MUSIC PUBLISHING CO., LTD.  
Sanan Bldg. 302,  
1 Toganomachi, Kita-ku, Osaka-shi, Japan  
President: Masaaki Hata  
Telephone: 312-5721

ALL STAFF MUSIC CO., LTD.  
6-3-1 Nishi-Azabu, Minato-ku, Tokyo, Japan  
President: Takao Imaizumi  
Telephone: 402-8281

BON MUSIC COMPANY  
5 Fukide-cho, Shiba, Minato-ku, Tokyo, Japan  
President: Yutaka Saitoh  
Telephone: 431-9431

FUJI TELECASTING MUSIC COMPANY LTD.  
Fuji TV-nai,  
7 Kawada-cho, Ichigaya, Shinjuku-ku, Tokyo, Japan  
President: Toshikene Boujo  
Telephone: 359-6177

ISHIHARA MUSIC PUBLISHING CORP.  
Kimuraya Bldg.,  
24 Toranomon, Shiba, Minato-ku, Tokyo, Japan  
President: Yuujiro Ishihara  
Telephone: 504-3441

NIHON ONGAKU SHUPPAN KABUSHIKI  
KAISHA (NICHION, INC.)  
TBS TV Dai-2 Kyokusha-nai,  
50-3-5 Akasaka, Minato-ku, Tokyo, Japan  
President: Shigeru Akimoto  
Telephone: 584-4711

PACIFIC MUSIC PUBLISHING CO., LTD.  
Nippon Hoso-nai,  
7-1 Yurakucho, Chiyoda-ku, Tokyo, Japan  
President: Tatsuhiro Ishida  
Telephone: 213-4009

SHINKO MUSIC PUBLISHING CO., LTD.  
Wako Bldg.,  
13-2 Kanda-Tsukasa cho, Chiyoda-ku, Tokyo, Japan  
President: Teiji Kusano  
Telephone: 292-2861

WATANABE MUSIC PUBLISHING CORP.  
4-1 Yurakucho, Chiyoda-ku, Tokyo, Japan  
President: Misa Watanabe  
Telephone: 502-2571

JAPAN: The Past 12 Mos.  
(Con't from Page 52)

the magic circle were "Yoru to Asa no Aidani" sung by Peter, "Kuroneko no Tango" sung by seven years old boy named Osamu Minagawa. Un-expected hits by movie actresses Chinatsu Nakayama and Ruriko Asaoka has brought public attention, and it gave an impetus showing the change of popular song in Japan.

Local groups, playing so called "Group Sounds" has lost popularity among teenagers because of the troubles and changes in the groups, after a five year of the golden period. New Rock, Hard Rock, and R.&B. are gaining popularity due to the strong campaign by the recording companies.

Foreign artist and groups who held performances in Japan during 1969 are: New Christy Minstrels in January, Astrud Gilberto in February, Human Beinz and Sam & Dave in March, Platters, Claudio Villa, Stanley Black & His Orchestra and Pat Boone & Osmond Brothers in

April, Xilly Vaughn Orchestra and Nancy Wilson in May, Oscar Peterson Trio, Peggy March, Harbie Mann, Eddie Fisher and Cascades in June, Brothers Four in August, Dizzy Gillespie Quintet, Newport All Stars, Brenton Wood and Frank Ifield in September, Sarah Vaughan, Enrico Macias, Cliff Richard, The Shadows and Carmen Villani in October, Al Bano, Adamo, Alfred Hause and Paul Mauriat Grand Orchestra in November, Gary Lewis & The Playboys, Osmond Brothers, Clara Ward Singers and Brenton Lee in December.

Most of the concerts were an box-office success as compared with the activities of previous year.

Remarkable inroads of big musical programs into TV programs was made in 1969. In the previous year, there were only three programs such as "Song Festival of Home Country" by NHK TV, "Grand Prize Songs" by TBS TV and "Hit Songs of This Week" by Fuji TV. Quarter, half, and one hour musical weekly programs by 6

(Con't. on Page 56)

## EASTERN ALWAYS CREATES MUSIC FOR WORLD'S HEARTS

POPULAR MUSIC AND SOUND SPECIALLY COLLECTED IN INDIA  
VOICES OF M.GANDHI, GREAT POET TAGOR,  
FOLK SONG, CHILDREN'S SONG,  
SNAKE DANCE MUSIC, INDIAN DANCE MUSIC.

DR. PAUL YODER'S BRASS BAND SERIES  
ON POPULAR MUSIC.  
MIGUEL BARBERA'S GUITAR SOLO  
ALBUMS.

EASTERN PUBLISHES AND REPRESENTS GREAT  
WORKS OF FAR EAST, AMERICA AND EUROPE.

**CATALOGUES REPRESENTED**

BIG THREE, F.D. & HUNTER, B. FELDMAN. DONNA, ROBBINS ENG.

# EASTERN MUSIC PUBLISHING CO.,LTD.

KYOWA BLDG., 34, SHIBA KOTOHIRA-CHO, MINATO-KU, TOKYO, JAPAN.



An old record company with fresh, new ideas  
 in producing and distributing  
 many labels—Japanese and international—  
**NIPPON COLUMBIA**  
 celebrates its 60th anniversary Oct. 1, 1970

 **NIPPON COLUMBIA CO., LTD.**  
 4-14-14 Akasaka, Minato-ku, Tokyo, Japan  
 Write for license details.

**LOCAL REPERTOIRE**

**DENON Records**  
 Furimuite Mitemo Vocal: Kayoko Moriyama  
 My Little Darling Vocal: Jimmy Osmond  
 Oh! Summer Vocal: Betsy & Chris  
 Watashidake no Mono Vocal: Yukari Ito  
**Japanese Classical & Folk Music**  
 Nagauta-Dance "Fuji-Musume"  
 Sokyoku "Chidori no Kyoku," "Matsukaze"  
 Nagauta "Genroku-Hanami-Odori," "Nanko"  
 "Anthology of Japanese Folk Music"

**Japanese Popular Singers**  
 Mieko Hirota, Ayumi Ishida, Naomi Chiaki,  
 Yukari Ito and other top Japanese popular singers.  
**CLASSICAL, CONTEMPORARY REPERTOIRE**  
**Classical Music**  
 Complete Album (No. 1-32) of Beethoven's Piano Sonatas  
 Pianist: Takahiro Sonoda  
 Complete Album (No. 1-9) of Beethoven's Symphonies  
 Hiroyuki Iwaki conducting the NHK Symphony Orchestra

**Contemporary Music of Japan**  
 Bugaku "Mandara Symphony"  
 Composer: Toshiro Mayuzumi  
 Hiroyuki Iwaki conducting the NHK  
 Symphony Orchestra  
 "Pieces for Prepared Piano & Strings"  
 Composer: Toshiro Mayuzumi  
 "Paraphrase After Japanese Ancient Music"  
 Composer: Minoru Miki

# JAPAN'S TAPE MANUFACTURERS

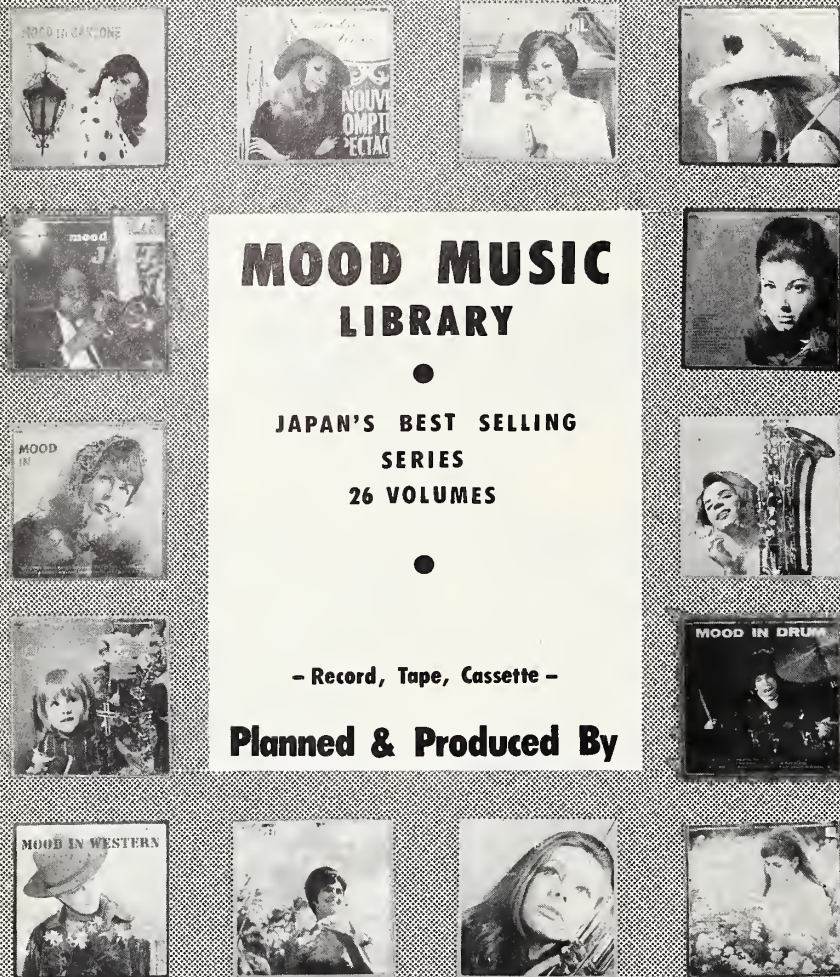

## MOOD MUSIC LIBRARY

JAPAN'S BEST SELLING SERIES  
26 VOLUMES

— Record, Tape, Cassette —

Planned & Produced By

## EASTERN SUN ENTERPRISES CO., LTD.

KYOWA BLDG., 34, SHIBA KOTOHIRA-CHO, MINATO-KU, TOKYO, JAPAN.

**APOLLON MUSIC INDUSTRIAL CORP.**  
5-1 Wakaba-cho, Shinjuku-ku, Tokyo, Japan  
President: Misa Watanabe  
Telephone: 353-0191

**ASAHI MUSIC SERVICE**  
2-2 Minami, Oyodo-cho, Oyodo-ku, Osaka-shi, Japan  
President: Takeshi Suzuki  
Telephone: 458-5321

**CBS/SONY RECORDS INC.**  
7-17-3 Roppongi, Minato-ku, Tokyo, Japan  
President: Norio Ohga  
Telephone: 585-0411

**CLARION TRADE CO., LTD.**  
2-35-5 Shiroyama, Bunkyo-ku, Tokyo, Japan  
President: Sanai Takizawa  
Telephone: 813-5151

**ECHO ENTERPRISES CO., LTD.**  
Dai-1 Fuji Bldg.,  
93-1 Kashiwagi, Shinjuku-ku, Tokyo, Japan  
President: Isao Kanoh  
Telephone: 369-0275

**FUJITSU LIMITED**  
Furukawa Sogo Bldg.,  
8-2 Marunouchi, Chiyoda-ku, Tokyo, Japan  
President: Kanjiro Okada  
Telephone: 216-3211

**KING RECORD CO., LTD.**  
13-12-2 Otowa, Bunkyo-ku, Tokyo, Japan  
President: Kazumitsu Machijiri  
Telephone: 941-3111

**MECCA RECORD PAK CORPORATION**  
Rousei Bldg.,  
4-1 Higashi-Azabu, Minato-ku, Tokyo, Japan  
President: Toshio Niimi  
Telephone: 584-5451

**NIKKATSU TAK**  
1-1 Yurakucho, Chiyoda-ku, Tokyo, Japan  
President: Kyuusaku Hori  
Telephone: 213-3211

**NIPPON COLUMBIA CO., LTD.**  
14-14-4 Akasaka, Minato-ku, Tokyo, Japan  
President: Jooji Kanzaki  
Telephone: 584-8111

**NIPPON CROWN CO., LTD.**  
Shinwa Bldg.,  
3-10-2 Akasaka, Minato-ku, Tokyo, Japan  
President: Kazuhisa Arita  
Telephone: 582-4741

**NIPPON GRAMMOPHON CO., LTD.**  
4-8-1 Ohhashi, Meguro-ku, Tokyo, Japan  
President: Shinken Izawa  
Telephone: 462-5131

**ORIENTAL MUSIC-TAPE & PUBLISHERS**  
Dai-2 Maruzen Bldg.,  
2-3 Nihonbashi-Edobashi, Chuo-ku, Tokyo, Japan  
President: Koozoo Nakamura  
Telephone: 272-3631

**PIONEER ELECTRONIC CORP.**  
5-15-4 Nishi, Ohmori, Ohta-ku, Tokyo, Japan  
President: Nozomu Matsumoto  
Telephone: 763-2111

**PONY PAK**  
Sekai-Boeki Center Bldg.,  
5-3 Hamamatsucho, Shiba, Minato-ku, Tokyo, Japan  
President: Tatsuroo Ishida  
Telephone: 435-4913

**TAIKO ELECTRIC WORKS-LTD.**  
13-10-6 Nakanobe, Shinagawa-ku, Tokyo, Japan  
President: Umehaburo Furukawa  
Telephone: 782-1111

**TBS SERVICE**  
TBS TV Dai-2 Kyokusha,  
50-3-5 Akasaka, Minato-ku, Tokyo, Japan  
President: Shigeru Akimoto  
Telephone: 582-7351

**TEICHIKU RECORD CO., LTD.**  
1-2 Nishi-Shinbashi, Minato-ku, Tokyo, Japan  
President: Toyoji Nankoo  
Telephone: 502-6651

**TOSHIBA MUSICAL INDUSTRIES LTD.**  
17-2-2 Akasaka, Minato-ku, Tokyo, Japan  
President: Yoosuke Kan  
Telephone: 585-1111

**VICTOR COMPANY OF JAPAN**  
3-14-2 Nagata-cho, Chiyoda-ku, Tokyo, Japan  
President: Hitoshi Momose  
Telephone: 581-3211

JAPAN: The Past 12 Mos.

(Con't. from Page 54)

TV stations in Tokyo were 20 in total 1967 — 1968 season. But, after the change of programming in October of 1968, the figure of weekly musical programs by above 6 stations has jumped to 42 including 10 or more one hour programs. With the increase of TV and radio programs, many hit

songs and singers have appeared on these programs. But, due to over exposure, the life of hit songs and sales of recordings have dropped. It is not a rarity to see the same singer singing the same song at the same time on different channel. Main reason of such great advance of music shows on TV and radio program is due to the fact that musical programs can be produced at much lower budget as compared with dramatic programs.



# apollon

**Music Industrial Corp.**

The Greatest and Oldest  
Music Tape Manufacturer  
& Distributor in Japan

PRESIDENT ■ Misa Watanabe

5,1-Chome Wakaba, Shinjuku-ku, Tokyo, Japan. TELEPHONE:TOKYO (353)0191

# THE GREATEST MUSIC ORGANIZATION IN THE FAR EAST



## VICTOR COMPANY OF JAPAN LTD.

MAIN OFFICE

4-1 NIHONBASHI-HONCHO CHUO-KU TOKYO

MUSIC ENTERPRISE DIVISION

AKASAKA TOKYU Bld.,

14-3, 2CHOME NAGATA-CHO CHIYODA-KU, TOKYO

TOKYO STUDIO

21-1, 2CHOME JINGUMAE

SHIBUYA-KU TOKYO

43 YEARS

OF HISTORY

IN THE INDUSTRY



CHAIRMAN: KŌNOSUKE MATSUSHITA



PRESIDENT: HITOSHI MOMOSE

← AFFILIATE COMPANY →

**VICTOR ARTISTS CORPORATION**  
**VICTOR PUBLISHING COMPANY LIMITED**

SUKIYABASHI Bld.,  
1-7, 5CHOME

GINZA CHUO-KU  
TOKYO

# JAPAN'S MUSIC PUBLISHERS



# TEICHIKU RECORDS is PROGRESSING!



RECORDS VIDEO TAPE CARTRIDGE TAPE CASSETTE TAPE MUSIC PUBLICATION

## TEICHIKU RECORDS CO., LTD.

Tokyo Main Office

Address : No. 1, 2-Chame, Nishi-Shinbashi, Minata-Ku, Tokyo, Japan

Cable : TEICHIKU TOKYO

President : TOYOJI NANKO

### ART MUSIC PUBLISHING CO., LTD.

Sanan Bldg. 302,  
1 Toganomachi, Kita-ku, Osaka-shi, Japan  
President: Masaaki Hata  
Telephone: 312-5721

### ABERBACH TOKYO KABUSHIKI KAISHA

P. O. Box 13,  
Seikai Bomeki Center Bldg. 32nd Floor,  
5-3 Hamamatsucho, Shiba, Minato-ku, Tokyo, Japan  
President: P. J. Sips  
Telephone: 435-5276

### ASTRO MUSIC

Lions Mansion Akasaka,  
6-5-7 Akasaka, Minato-ku, Tokyo, Japan  
President: Hideko Kobayashi  
Telephone: 585-1094

### AI MUSIC, INC.

Akasaka-Dai Mansion 101,  
11-6-7 Akasaka, Minato-ku, Tokyo, Japan  
President: Kazuko Kusaka  
Telephone: 583-6231

### ASAHI BROADCASTING CORPORATION

2-2 Minami, Oyodo-cho, Oyodo-ku, Osaka-shi, Japan  
President: Tsunejiro Hirai  
Telephone: 458-5321

### A. SCHROEDER MUSIC (FAR EAST) LTD.

Asahina Horitsu Jimusho-nai,  
Sumitomo Bldg. 832,  
2-1 Marunouchi, Chiyoda-ku, Tokyo, Japan  
President: Masami Yamashiro  
Telephone: 211-6747

### ALL AOYAMA MUSIC CO.

Yoshitaka Kiryu-kata,  
13-26-4 Kamiogi, Suginami-ku, Tokyo, Japan  
President: Yoshitaka Kiryu  
Telephone: 399-7231

### ALL STAFF MUSIC CO., LTD.

6-3-1 Nishi-Azabu, Minato-ku, Tokyo, Japan  
President: Takao Imaizumi  
Telephone: 402-8281

### BIG HILL MUSIC PUBLISHERS

Chateau Akasaka,  
22-5-6 Akasaka, Minato-ku, Tokyo, Japan  
President: Norikazu Okada  
Telephone: 582-7870

### BROADCAST MUSIC PUBLISHERS

Tomoeya Bldg. 401,  
6-13-2 Akasaka, Minato-ku, Tokyo, Japan  
President: Tetsuro Iwata  
Telephone: 585-5984

### BERB MUSIC PUBLISHING CORP.

Shin-Akasaka Mansion,  
14-7-6 Akasaka, Minato-ku, Tokyo, Japan  
President: Yutaka Satake  
Telephone: 585-3471

### CROWN MUSIC PUBLISHER, Inc.

Shinwa Bldg.,  
8-10-2 Akasaka, Minato-ku, Tokyo, Japan  
President: Taketsuna Kamei  
Telephone: 582-4741

### C.A.L. MUSIC PUBLISHING, TOKYO

Art Residence,  
10-15-4 Jingumae, Shibuya-ku, Tokyo, Japan  
President: Tetsuro Aoyagi  
Telephone: 401-6908

### CBS/SONY RECORD INC.

7-17-3 Roppongi, Minato-ku, Tokyo, Japan  
President: Akio Morita  
Telephone: 585-0411

### DISNEY, WALT ENTERPRISES OF JAPAN LTD.

4-5-2 Shinbashi, Minato-ku, Tokyo, Japan  
President: Matsuo Yokoyama  
Telephone: 591-5886

### DAIEI MUSIC PUBLICATION CO., LTD.

2-2-3 Kyobashi, Chuo-ku, Tokyo, Japan  
President: Hidemasa Nagata  
Telephone: 281-5171

### DAIICHI MUSIC PUBLISHER

Itoh Bldg. 2nd Floor  
16-6-3 Kasumigaseki, Chiyoda-ku, Tokyo, Japan  
President: Eiichi Honma  
Telephone: 580-0551

### DARE CO., LTD.

Gotoh Bldg. 422,  
3-1-5 Roppongi, Minato-ku, Tokyo, Japan  
President: Eiichi Honma  
Telephone: 408-8215

### DAY & NIGHTS MUSIC PUBLISHING CORPORATION

20-5-4 Minami-Nagasaki, Toshima-ku, Tokyo, Japan  
President: Kunitoshi, Fujiwara  
Telephone: 951-6445

### EASTERN MUSIC PUBLISHING CO., LTD.

Kyowa Bldg.,  
34 Kotohira-cho, Shiba, Minato-ku, Tokyo, Japan  
President: Masami Isomura  
Telephone: 501-0344

### ECHO ENTERPRISES CO., LTD. (EEC)

Shinjuku Daiichi Fuji Bldg.,  
93-1 Kashiwagi, Shinjuku-ku, Tokyo, Japan  
President: Isao Kanoh  
Telephone: 369-0271

### FAR EAST MUSIC PUBLISHING CORP.

c/o Sadao Ochiai,  
9-3-3 Kami-Renjaku, Mitaka-shi, Tokyo, Japan  
President: Sadao Ochiai  
Telephone: 43-4016

### FUJI TELECASTING MUSIC COMPANY LTD.

Fuji TV-nai,  
7 Kawada-cho, Ichigaya, Shinjuku-ku, Tokyo, Japan  
President: Toshikane Boujo  
Telephone: 359-6177

(Con't. on Page 60)

# ALL AROUND MUSICMAN

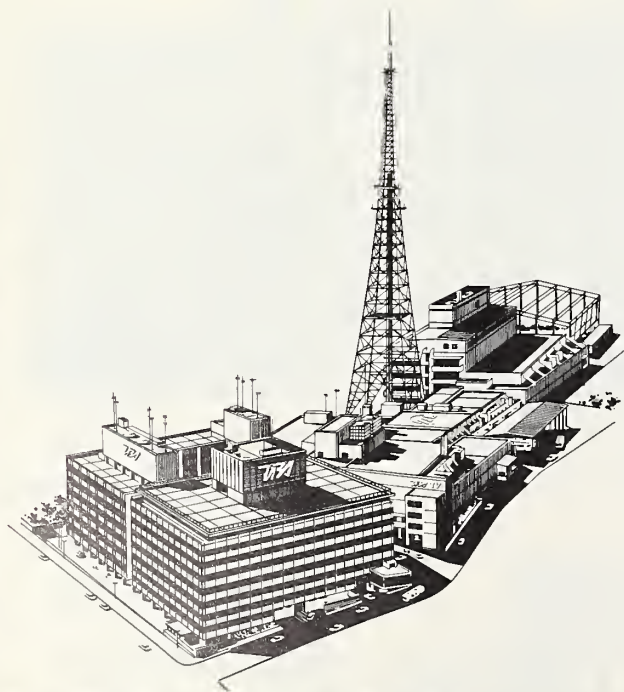

## NICHION

Biggest plus Most Active

# NICHION

- Subsidiary of TBS (The Foremost National Radio & TV Network)
- Representative for Warner Bros. Music, Inc., Campbell Connelly & Co. Ltd., and others
- Full Promotion of Foreign Songs
- Plenty of Japanese Hit Songs
- Music Publications
- Producing Master Records
- Merchandising
- President: SHIGERU AKIMOTO
- Address: TBS TV 2nd Bldg., No. 3-50, 5-chome, Akasaka, Minato-ku, Tokyo
- Cable: "PUBLISHMUSIC TOKYO"
- Phone: Tokyo (584)4711



**FOREMOST  
AND  
MOST PROGRESSIVE  
RECORD COMPANY  
OF JAPAN**

**Covering Local and International Records, Tapes, Video-tapes and Music Publishing**



**TOSHIBA MUSICAL INDUSTRIES LTD.**

**TOSHIBA MUSIC PUBLISHING CO. LTD.**

**TOKYO**

**JAPAN**

LO VE

THIS ASSOCIATION CONSISTS OF THREE  
COMPANYS CREATES THE POPULAR SONGS  
TO REVOLUTIONIZE.

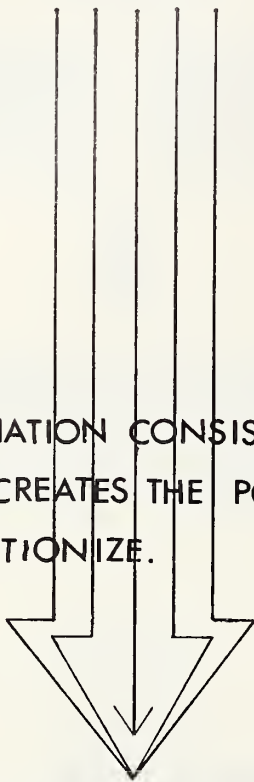

MUSIC PROMOTE	<b>OZAWA</b>
MUSIC PROMOTE	<b>ALT</b>
MUSIC PUBLISHER	<b>JUN&amp;KEI</b>
MIKADO BLDG 4-11-9 ROPPONGI	
MINATO-KU TOKYO PHONE (404) 4547	

# JAPAN'S MUSIC PUBLISHERS

(Con't. from Page 58)

**FRIENDSHIP MUSIC, INC.**  
20-7-7 Minami-Aoyama, Minato-ku, Tokyo, Japan  
President: Kou Sugiura, Kenji Murakami  
Telephone: 400-9656

**FUJI INTERNATIONAL MUSIC CO., LTD.**  
25 Higashi-Goken cho, Shinjuku-ku, Tokyo, Japan  
President: Shinpei Matsuoka  
Telephone: 269-0121

**FUJI MUSIC, INC.**  
Gaien Bldg. 412,  
8-23-2 Minami-Aoyama, Minato-ku, Tokyo, Japan  
President: Kiheiji Amano  
Telephone: 403-0841

**FURUKAWA MUSIC PUBLISHERS**  
Tokyo Ongaku-nai,  
8-3 Kyobashi, Chuo-ku, Tokyo, Japan  
President: Shingo Furukawa  
Telephone: 281-7750

**GRAMMOPHON PUBLISHING & PROMOTION K.K.**  
4-8-1 Ohhashi, Meguro-ku, Tokyo, Japan  
President: Shinken Izawa  
Telephone: 462-5131

**GEI-EI MUSIC PUBLISHERS**  
Nakamura Bldg.,  
13-13-1 Akasaka, Minato-ku, Tokyo, Japan  
President: Chikara Suzuki  
Telephone: 584-0901

**GENDAI KIKAKU ONGAKU SHUPPAN**  
Gyoen Height 504,  
1 Naitoh-cho, Shinjuku-ku, Tokyo, Japan  
President: Michiko Araki  
Telephone: 354-5586

**HAYABUSA MUSIC PUBLISHING CO., LTD.**  
Shouei Bldg. 3 Floor,  
5 Hayato-cho, Chiyoda-ku, Tokyo, Japan  
President: Tatsuo Miyata  
Telephone: 262-3308

**HARA MUSIC PUBLISHERS CO., LTD.**  
Noboru Uehara-kata,  
5-2-1 Shiroganedai, Minato-ku, Tokyo, Japan  
President: Noboru Uehara  
Telephone: 441-5547

**HEIBON PUBLISHING CO., LTD.**  
11-3 Higashi, Ginza, Chuo-ku, Tokyo, Japan  
President: Kinosuke Iwabori  
Telephone: 541-3211

**INTERNATIONAL MUSIC PUBLISHERS CO., LTD.**  
Mansui Bldg.,  
14-3 Ogawa-cho, Kanda, Chiyoda-ku, Tokyo, Japan  
President: Yookichi Kitagawa  
Telephone: 292-7256

**ISHIHARA MUSIC PUBLISHING CORP.**  
Kimuraya Bldg.,  
24 Toranomon, Shiba, Minato-ku, Tokyo, Japan  
President: Yuujiro Ishihara  
Telephone: 504-3441

**JUN & KEI MUSIC PUBLISHERS, INC.**  
Mikado Bldg. 3 Floor,  
9-11-4 Roppongi, Minato-ku, Tokyo, Japan  
President: Jun Ozawa  
Telephone: 401-4293

**JAPAN CENTRAL MUSIC, LIMITED (JCM)**  
Bunka Hoso-nai,  
5-1 Wakaba, Shinjuku-tu, Tokyo, Japan  
President: Takaei Minami  
Telephone: 359-7825

**JAPAN-SOVIET MUSIC INC.**  
23-1 Nishiki-cho, Kanda, Chiyoda-ku, Tokyo, Japan  
President: Youichi Noguchi  
Telephone: 255-5642

**JAPAN C.A.M. LIMITED**  
Playguide Bldg.,  
4-6-2 Ginza, Chuo-ku, Tokyo, Japan  
President: Nagamasa Kawakita  
Telephone: 562-0111

**JAPAN BROADCAST PUBLISHING CO., LTD.**  
18-1-2 Uchisaiwai-cho, Chiyoda-ku, Tokyo, Japan  
President: Masao Katoh  
Telephone: 501-4111

**KAMINARI MUSIC PUBLISHER INC.**  
Nakada Mansion 3F-3,  
14-12-5 Jingumae, Shibuya-ku, Tokyo, Japan  
President: Norikazu Okada  
Telephone: 400-7778

**KAWAI GAKUFU CO., LTD.**  
7-6-2 Komagome, Toshima-ku, Tokyo, Japan  
President: Hisashi Shimizu  
Telephone: 910-7428

**KANAI MUSIC PUBLISHERS**  
Takaku Bldg. 3 Floor,  
8-2 Nishi, Ebisu, Shibuya-ku, Tokyo, Japan  
President: Hiroshi Hara  
Telephone: 461-2107

**KIKURA MUSIC PUBLISHERS**  
34-26-2 Nishi-Azabu, Minato-ku, Tokyo, Japan  
President: Hiroyasu Kikura  
Telephone: 400-8328

**KYOEI MUSIC PUBLISHER**  
Dai-1 Kyoei-nai,  
3-2 Yotsuya, Shinjuku-tu, Tokyo, Japan  
President: Hiromasa Fukuoka  
Telephone: 353-7491

**KUSANO MUSIC, INC.**  
Wako Bldg.,  
13-2 Kanda-Tsukasa cho, Chiyoda-ku, Tokyo, Japan  
President: Shoichi Kusano  
Telephone: 292-2861

**KODAMA MUSIC PUBLISHING CO., LTD.**  
58-2 Shinjuku, Shinjuku-ku, Tokyo, Japan  
President: Shooko Takagi  
Telephone: 356-3079

(con't on next page)

**MOST IMPROVED MUSIC PUBLISHER**

IN JAPAN

\* We have copyrights of many hit  
song in Japan:

\* Those who wish to have contract of  
subpublishment will write to us.

\* Catalogue in English is available.



**CROWN MUSIC PUBLISHER, INC.**

Akasaka 2-10-8,  
Minatoku, Tokyo, Japan

## WE RECOMMEND YOU OUR CLASSICAL LP RECORDS

■ SW-5010-5011 (12" s)  
JAPANESE MUSIC FOR YOUR SOUVENIR

In these two records we have collected  
different kinds of representative Japanese  
musical selections.

In these two records we have  
collected different kinds of representa-  
tive Japanese musical selections.

One contains the classical and  
traditional musical selections, the  
other, outstanding folk songs.

Each selection is performed by  
first class players prepared for  
foreign music lovers.

■ LW-5070 (12" s)

**KOTO MUSIC**

(Sokyoku Tegoto-Shu Vol.2)

Koto solos, duets, trios by Soyo  
Nakamura & his Ensemble.

Side A: 7 classical koto pieces,

"Kaede no Hana", etc.

Side B: 6 modern Koto pieces,

"Kawabe no Ame", etc.

■ SWS-3 (12" S)

**SHAKUHACHI 1969**

Shakuhachi, Japanese bamboo flute,  
gives marvelous sounds of unique atmos-  
phere of Japan.

These musical selections were  
composed for the 1969 Arts Festival  
by modern composer, Ryohei Hirose who  
won first prize.

Composition for Shakuhachi, strings  
and percussions/Haré for 3 Shakuhachi

● Shakuhachi Trio

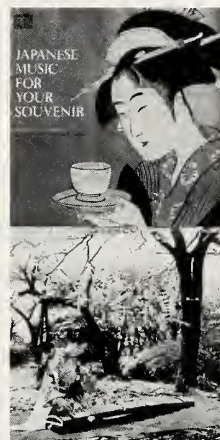

— Catalogue available —

**CROWN**  
**NIPPON CROWNCO., LTD.**

Akasaka 2-10-8, Minatoku, Tokyo, Japan



# JAPAN'S MUSIC PUBLISHERS

(cont from preceding page)

## KOKUSAI MUSIC PUBLISHERS (K.M.P.)

Nippon Chusha Bldg., 6th Floor,  
43 Toyama-cho, Shinjuku-ku, Tokyo, Japan  
President: Nobuo Nishikawa  
Telephone: 203-7672

## LUCKY CHILD

247-1 Okuzawa-cho, Tamagawa, Setagaya-ku,  
Tokyo, Japan  
President: Masami Yamamoto  
Telephone: 727-3106

## MUSIC PUBLISHER SUISEI-SHA

30-6 Kagurazaka, Shinjuku-ku, Tokyo, Japan  
President: Sansaku Meguro  
Telephone: 268-0236

## MUSIC PUBLISHER HIT MAKER. LTD.

Tokyo Gakki Shokai-nai, Mansui Bldg.,  
14-3 Kanda-Ogawa-cho, Chiyoda-ku, Tokyo, Japan  
President: Masaru Idebuchi  
Telephone: 292-7256

## MANASE MUSIC PUBLISHING CO., LTD.

Mitoko Bldg.,  
4-2-6 Akasaka, Minato-ku, Tokyo, Japan  
President: Hanako Manase  
Telephone: 584-5511

## MAHINA MUSIC PUBLISHING CORPORATION

Dai-8 Mori Bldg.,  
4-20-3 Nishi-Shinbashi, Minato-ku, Tokyo, Japan  
President: Hiroshi Wada  
Telephone: 433-5321

## MUSICAL RIGHTS (TOKYO) K.K.

Zenkyoren Bldg., 409,  
7-2 Hirakawa-cho, Chiyoda-ku, Tokyo, Japan  
President: Susumu Kojima  
Telephone: 265-3291

## MUSIC EIGHT CO., LTD.

1-7-2 Taishido, Setagaya-ku, Tokyo, Japan  
President: Yoshikichi Sukeyasu  
Telephone: 411-2543

## MUSIC FRIEND PUBLISHER

Murata Bldg., 8th Floor,  
27-4 Yoyogi, Shibuya-ku, Tokyo, Japan  
President: Masami Kikuchi  
Telephone: 585-0751

## MUSIFON, INC. OF JAPAN

Hatsumei-Kaikan, FM tokai-nai,  
17 Aketune-cho, Nishi-Kubo, Shiba, Minato-ku,  
Tokyo, Japan  
President: Nobuo Kimura  
Telephone: 502-0431

## MYRICA MUSIC PUBLISHING CO., LTD.

Mainichi Hoso Senrigaoka Studio-nai,  
297 Yamada-Shita, Fukita-shi, Osaka, Japan  
President: Masayasu Kitao  
Telephone: 388-1341

## NIPPON COLUMBIA MUSICAL ENTERPRISES LTD.

(NICOLME)  
14-14-4 Akasaka, Minato-ku, Tokyo, Japan  
President: Tetsuo Maruyama  
Telephone: 584-8111

## NEW ORIENT MUSIC INC.

Akasaka Mansion 22,  
16-5-7 Akasaka, Minato-ku, Tokyo, Japan  
President: Seiji Itoh  
Telephone: 583-2898

## NEW-SOUND MUSIC PUBLISHERS CO., LTD.

Fujikawa Bldg.,  
23-4 Yotsuya, Shinjuku-ku, Tokyo, Japan  
President: Kenji Nakajima  
Telephone: 359-9815

## NISSO MUSIC PUBLISHING CO.

6-36-1 Yoyogi, Shibuya-ku, Tokyo, Japan  
President: Shigeyuki Akamatsu  
Telephone: 379-2471

## NIPO-AMERICANA MUSIC PUBLISHING CO., LTD.

2-20-4 Imagawa, Suginami-ku, Tokyo, Japan  
President: Teruo Higashikubo  
Telephone: 271-2170

## NIHON ONGAKU SHUPPAN KABUSHIKI KAISHA

(NICHION, INC.)  
TBS TV Dai-2 Kyokusha-nai,  
50-3-5 Akasaka, Minato-ku, Tokyo, Japan  
President: Shigeru Akimoto  
Telephone: 584-4711

## NIHON KAYO MUSIC PUBLISHING CO., LTD. (N.M.P.)

8-6-2 Yoyogi, Shibuya-ku, Tokyo, Japan  
President: Tatsuzo Narima  
Telephone: 379-1415

## ORIENTAL MUSIC CO. (OMC)

13-22-2 Daizawa, Setagaya-ku, Tokyo, Japan  
President: Tadashi Yoshida  
Telephone: 421-4123

## OHTA MUSIC PUBLISHERS, INC.

Prince Bldg.,  
1-10-5 Ginza, Chuo-ku, Tokyo, Japan  
President: Kooji Ohta  
Telephone: 572-0066

## ONGAKU SHUPPAN CENTER CO., LTD. TOKYO

Saitoh Bldg.,  
7-3 Takara-cho, Chuo-ku, Tokyo, Japan  
President: Rinnosuke Kondo  
Telephone: 567-6024

## ONGAKU SHUNJUSHA, LTD.

30-1 Kanda-Jinbo cho, Chiyoda-ku, Tokyo, Japan  
President: Kazuo Uchino  
Telephone: 291-0360

## ONGAKU-NO TOMOSHA CORP.

30-6 Kagurazaka, Shinjuku-ku, Tokyo, Japan  
President: Sansaku Meguro  
Telephone: 268-6151

(cont on next page)



# ISHIHARA

## MUSIC PUBLISHING CORP.

Music Publishing

Producer of Many Hit Songs

Active Record Master Production

PRESIDENT YUJIRO ISHIHARA  
ISHIHARA MUSIC PUBLISHING CORP.  
ADDRESS KIMURAYA BLDG., 24, SHIBA-  
TORANOMON MINATO-KU,  
TOKYO, JAPAN  
TEL 504-3 4 4 1

JAPAN'S \* Shoo Kusano

# SHINKO

## MUSIC PUBLISHING CO., LTD.

Music Publishing  
Musical Books Publication  
Instrument Deals  
Monthly Popular Music Magazine  
*musicLife*  
and Active  
Record Master Production

Address: Wako Bldg., 2-chome, Tsukasa-cho Kanda,  
Chiyoda-ku, Tokyo, Japan  
Cable: Shinkomusic Tokyo  
TEL. (292) 2861 ~ 2868





# ZEN-ON

## THE GREATEST & OLDEST MUSIC PUBLISHERS IN JAPAN

Since its first publication of musical scores in 1931, ZEN ON has become very popular as the best musical scale publisher in Japan. Its repertoire ranges widely from modern popular songs to classical.

Address: No. 25 Higashigoken-cho. Shinjuku-ku TOKYO JAPAN  
Phone: (269) 0121-0127

Affiliated: **OVERSEAS MUSIC PUBLISHERS Co., Ltd.**  
**PAMPER MUSIC OF JAPAN LTD.**  
**FUJI INTERNATIONAL MUSIC CO., LTD.**

# JAPAN'S MUSIC PUBLISHERS

(con't from preceding page)

**OVERSEAS MUSIC PUBLISHERS CO., LTD. (O.M.P.)**  
25 Higashi Goken cho, Shinjuku-ku, Tokyo, Japan  
President: Eijiro Shimada  
Telephone: 260-1426

**PAMPER MUSIC OF JAPAN, LTD.**  
25 Higashi-Goken cho, Shinjuku-ku, Tokyo, Japan  
President: Shinpei Matsuoka  
Telephone: 269-0121

**PACIFIC MUSIC PUBLISHING CO., LTD.**  
Nippon Hoso-nai  
7-1 Yurakucho, Chiyoda-ku, Tokyo, Japan  
President: Tatsuhiro Ishida  
Telephone: 213-4009

**RHYTHM MUSIC PUBLISHER, INC.**  
Shin-Aoyama Kyodo Bldg. 6th Floor 63,  
15-9-5 Minami-Aoyama, Minato-ku, Tokyo, Japan  
President: Kuranosuke Hamaguchi  
Telephone: 409-8292

**REVUE JAPAN, LTD.**  
Hotel New Japan 882,  
8-13-2 Nagata-cho, Chiyoda-ku, Tokyo, Japan  
President: Richard S. Miyamoto  
Telephone: 581-2143

**ROW MUSIC CO.**  
Kasumi-cho Mansion 4A,  
36-17-3 Nishi-Azabu, Minato-ku, Tokyo, Japan  
President: Kazuo Tamai  
Telephone: 403-6844

**S & T MUSIC PUBLISHER**  
5 Fukide-cho, Shiba, Minato-ku, Tokyo, Japan  
President: Kyoko Takeda  
Telephone: 431-9431

**SUN MUSIC PUBLISHERS CO., LTD.**  
Miyasaka Bldg.,  
7 Sankocho, Shinjuku-ku, Tokyo, Japan  
President: Yoshiroo Arizawa  
Telephone: 352-8824

**SAN MUSIC PUBLISHING CO., LTD.**  
New Ginza Bldg.,  
13-3-7 Ginza, Chuo-ku, Tokyo, Japan  
President: Tetsuo Ando  
Telephone: 572-8060

**SHOGAKUKAN PRODUCTION CO., LTD.**  
Shoko Bldg.,  
4-29-1 Kanda-Jinbo cho, Chiyoda-ku, Tokyo, Japan  
President: Tetsuo Aiga  
Telephone: 265-3091

**SHINGEI PUBLISHERS CO., LTD.**  
11-10-2 Ginza, Chuo-ku, Tokyo, Japan  
President: Hirotsugu Kadama  
Telephone: 541-6659

**SHINKO MUSIC PUBLISHING CO., LTD.**  
Wako Bldg.,  
13-2 chome Kanda-Tsukasa cho, Chiyoda-ku,  
Tokyo, Japan  
President: Teiji Kusano  
Telephone: 292-2861

**STARLIGHT MUSIC PUBLISHERS CO., LTD.**  
3516 Kitami-cho, Setagaya-ku, Tokyo, Japan  
President: Hiroyasu Iwasaki, Haruo Kofuji  
Telephone: 416-7555

**STONE-WELLS MUSIC PUBLISHERS**  
Fuugetsudo Bldg.,  
1-6-6 Nishi, Ginza, Chuo-ku, Tokyo, Japan  
President: Yoshiko Ishii  
Telephone: 572-0355

**SEVEN SEAS MUSIC CO., LTD.**  
King Record Otsuka Bunshitsu-nai,  
Shin-Meikei Bldg.,  
1-3-3 Otsuka, Bunkyo-ku, Tokyo, Japan  
President: Kazumitsu Machijiri  
Telephone: 944-5447

**SELECT MUSIC PUBLISHERS CO.**  
667-2 Shimotakaido, Suginami-ku, Tokyo, Japan  
President: Kimiyasu Ryuu  
Telephone: 303-0372

**SHOIN MUSIC PUBLISHERS CO., LTD.**  
9-48-5 Denenchofu, Ohta-ku, Tokyo, Japan  
President: Yurika Naitoh  
Telephone: 721-4246

**TAKAHASHI MUSIC PUBLISHING INC.**  
Zen-Nikkanko Bldg.,  
3-3-1 Moto-Akasaka, Minato-ku, Tokyo, Japan  
President: Masami Takahashi  
Telephone: 404-8648

**TANABE MUSIC PUB. CO., LTD.**  
Akasaka Bldg. 6th Floor  
32-1-4 Akasaka, Minato-ku, Tokyo, Japan  
President: Shoochi Tanabe  
Telephone: 585-3721

**TAIYO MUSIC, INC.**  
Maruyama Bldg. 7th Floor,  
25-3 Azabu-Ikura, Minato-ku, Tokyo, Japan  
President: Tatsuji Nagashima  
Telephone: 585-3481

**TAIKEIYO MUSIC PUBLISHING CORP.**  
3-5 Ginza, Chuo-ku, Tokyo, Japan  
President: Aki Shimizu  
Telephone: 572-4541

**TERAUCHI MUSIC PUBLISHING CORP.**  
34-2 Aioi-cho, Naka-ku, Yokohama-shi,  
Kanagawa-ken, Japan  
President: Takeshi Terauchi  
Telephone: 681-5335

**TOKYO INTERNATIONAL MUSIC PUBLISHING CO.**  
Moto-Akasaka Bldg. 306,  
3-3-1 Moto-Akasaka, Minato-ku, Tokyo, Japan  
President: Nakako Imai  
Telephone: 403-5914

**TOA MUSIC CO.**  
Ongakunotomoshonai,  
30-6 Kagurazaka, Shinjuku-ku, Tokyo, Japan  
President: Jun Asaka  
Telephone: 268-0231

(con't on next page)

# JAPAN'S PROUD ONE

Japan's proud one "MECCA RECORD-PAK CO., LTD." is the oldest pre-recorded music tape manufacturer in Japan.

SOUND THAT GOES IN YOUR HEART  
SOUND THAT MOVES YOUR HEART  
SOUND THAT CATCHES YOUR HEART  
AND NEVER LEAVES  
THERE IS A HEART IN MECCA  
THERE IS MOTION IN IT.  
THAT IS ONE WHICH THE YOUTH  
IN THE WORLD UNDERSTAND MOST.



1-18 Nishiura-cho Higashi-ku Nagoya Japan Phone Nagoya (962) 3846  
**MECCA RECORD-PAK CO., LTD.**

LEADING PUBLISHERS

# ABERBACH TOKYO



# TOKYO MUSIC

IN

JAPAN

ABERBACH TOKYO K.K. TOKYO MUSIC PUBLISHING CO., LTD.

P.O. Box. 13, TRADE CENTER, TOKYO 105, JAPAN

# JAPAN'S MUSIC PUBLISHERS

(Con't from preceding page)

**TONE MUSIC CO., LTD.**  
Dai-3 Mori Bldg. 3rd Floor,  
10-4-1 Nishi-Shinbashi, Minato-ku, Tokyo, Japan  
President: Katsumata Katoh  
Telephone: 502-8214

**TOP MUSIC PUBLISHING CO., LTD.**  
Kiyo Bldg. 2nd Floor,  
1-9-3 Akasaka, Minato-ku, Tokyo, Japan  
President: Takeo Hori  
Telephone: 584-7581

**TOKYO MUSIC PUBLISHING CO.**  
22-5-1 Kohinata, Bunkyo-ku, Tokyo, Japan  
President: Takao Miyagawa  
Telephone: 946-1313

**TOKYO MUSIC PUBLISHING CO., LTD.**  
P. O. Box 13,  
Sekai Boeki Center Bldg. 32nd Floor,  
5-3 Hamamatsucho, Shiba, Minato-ku, Tokyo, Japan  
President: P. J. Sips  
Telephone: 435-5276

**TOSHIBA MUSIC PUBLISHING CO., LTD.**  
Akasaka Bldg. 5th Floor,  
32-1-4 Akasaka, Minato-ku, Tokyo, Japan  
President: Hanichiro Ishizaka  
Telephone: 583-1131

**TOHO MUSIC PUBLISHING CO., LTD.**  
21-4 Koujimachi, Chiyoda-ku, Tokyo, Japan  
President: Sakae Koyama  
Telephone: 262-2448

**TOYO-KIKAKU MUSIC PUBLISHING CO., LTD.**  
7-2-6 Ginza, Chuo-ku, Tokyo, Japan  
President: Kazuko Tani  
Telephone: 571-1545

**UNITED ARTISTS MUSIC (JAPAN), INC.**  
Maruyama Bldg. 7th Floor,  
25-3 Azabu-Ikura, Minato-ku, Tokyo, Japan  
President: Tatsuji Nagashima  
Telephone: 585-3481

**UNION PUBLISHER COMPANY**  
25 Ichibancho, Chiyoda-ku, Tokyo, Japan  
President: Toshinori Ebina  
Telephone: 262-5580

**VICTOR PUBLISHING CO., LTD. OF JAPAN**  
Sukiyabashi Bldg. 5th Floor,  
7-1-5 Ginza, Chuo-ku, Tokyo, Japan  
President: Kiichiro Itoh  
Telephone: 573-1541

**WATANABE MUSIC PUBLISHING CORP.**  
Matsui Bldg. 4th Floor,  
4-1 Yurakuchō, Chiyoda-ku, Tokyo, Japan  
President: Misa Watanabe  
Telephone: 502-2571

**YAMADA MUSIC CORPORATION**  
6-4-3 Akatsutsumi, Setagaya-ku, Tokyo, Japan  
President: Kousaku Yamada  
Telephone: 321-9564

**ZEN-ON MUSIC PUBLISHERS CO., LTD.**  
25 Higashi-Goken cho, Shinjuku-ku, Tokyo, Japan  
President: Eijiro Shimada  
Telephone: 269-0121

## GERMANY: The Past 12 Mos.

(Con't. from Page 49)

US star Henry "Manolito" Darrow got in Munich as special award a TV Bambi for "High Chaparral" . . . "Stern-Musik," founded in the spring of 1965 as a service for the 10.6 million readers of the big magazine "Stern" sold three million copies on 150 LP's. On the occasion of the five years existence of "Stern-Musik" the five partners from the record trade, Ariola, CBS, Decca, Deutsche Grammophon and Liberty made a co-operative advertising . . . Udo Juergens handed over a check for 2 million DM (540,000 dollars) to Wilhelmine Luebke, honorary president of the German "Altershilfe"

(old age relief) and the "Muettergenesungswerk" (maternity home), representing all the performers on the "Hour Of The Stars." The check represents the net profit of the sales of one million copies of the album.

### MAY 1970

The music-production Kurt Feltz, Cologne, celebrated their 20-years existence. Since 1950 this production has led numerous artists and songs to success including Caterina Valente and Peter Alexander . . . In Hamburg a contract between Deutsche Grammophon Gesellschaft and Colonial Trading Co. (Diamond Music) has been signed. As new firm Polydor Ltd., Hong Kong, was founded

(Con't. on Page 68)

## PLANNING TO ENTER THE JAPANESE MARKET?

A difficult task because of the distances involved, difference of language, custom and business practices. Of course, you would want a fair share of the important Japanese Music Market.

Some of our services:

- \* Marketing reseach
- \* Acting as licensing agent
- \* Acting as sub-publisher
- \* Sales promotion

Let us show you the way. Write:

## 'HARA MUSIC PUBLISHERS, LTD.

2-5, Shirokanedai 1-chome  
Minatoku, Tokyo 108, JAPAN

## Hamaguchi Kuranosuke. & Kimura Music

6115 SELMA AVE.  
HOLLYWOOD, CALIFORNIA 90028  
TELEPHONE—HOLLYWOOD 4-7781

## Rhythm Music Publisher

(K. HAMAGUCHI MUSIC OFFICE)  
6F-63 SHIN-AOYAMA KYODO BUILD  
MINAMIAOYAMA MINATOKU  
TOKYO-JAPAN

## MUSIC FOR YOU

### FOREIGN TALENT PROMOTIONS / ARTISTS UNDER OUR MANAGEMENT

ALFRED

HAUSE

CHARLES

TRENET

ENRICO

MACIAS

GEORGES

JOUVIN

JEAN

SABLON

KESLLER

SISTER

VICKY

YVETTE

GIRAUD

HIROSHI

ASHINO

YOSHIKO

ISHII

YOKO

KISHI

YASUKO

OHKI

TOKIKO

KATO

MIYOKO

TASHIRO

MIKI

HORIUCHI

NORIKO

TANAKA



YOSHIKO ISHII



YOKO KISHI

 ISHII MUSIC PROMOTION

 stone wells music publishers

fugetsudo bldg. 6-6-1 ginza, chuo-ku, tokyo, japan telephone 572-0351  
cable address: ISHII MUSIC TOKYO

President • YOSHIKO ISHII

General Manager • KYO ASABUKI/HARUMITSU HATTORI

You want  
active promotion  
of your songs?

it's

# NEW ORIENT MUSIC INC

in  
Japan

Akasaka Mantion, 16-5-7 Akasaka, Minatoku, TOKYO, Japan  
TEL: Tokyo 583-8718, 8719, 2898 Cable: NEWORIMUS, TOKYO

# ARGENTINA: The Past 12 Months

As every year we handle the job of describing in a few pages the whole life of the record, publishing and producing industry of Argentina, it becomes increasingly evident that the policy of global information started by Cash Box more than ten years ago foresaw an era of mutual interdependence between markets that were previously completely isolated, and now, entering the seventies, are following the world trends with a delay of only a few days and, in some cases, hours. Only the advent of the jet plane, reducing travelling distance by two thirds if measured in hours, equals the impact of this availability of "instant information" about what's happening in the fifteen or twenty most important places of the five continents, and making it necessary to make decisions involving policies, money and talent so often as to maintain one's company at the pace of the whole International industry.

The 1969/70 period has been outstanding because of many reasons: first of all, it marked the appearance of the independent producer as an institution, after experiments that could be considered as essays or attempts during the previous two or three years: at a certain moment, indie producers dominated about fifty percent of the charts, and a good part of the rest of the local product was, in a way or other, also produced by indies not depending directly on a payroll.

Another reason for excitement was the relevant share of the sales obtained by local beat music, channeled through beat groups and also by soloists giving it a more or less local flavor, but undoubtedly related to the music and recording techniques coming from Europe, Britain and the States. Unfortunately, the movement was unable to maintain itself at the same level of development of the originals, and its crisis brought a lowering in the total sales of the industry, evident in the first months of 1970, and which hasn't still been recovered, al-

though there are some promising signs for the near future. This decay opened the door for the entry of a strong bunch of American product, headed by Johnny Rivers, Creedence Clearwater Revival and others, and a new kind of hybrid recordings, already tried before, but never in such a scale: Italian songs, by its original artists, in Spanish. This move, led and successfully mastered by RCA, is one of the most significant events in the history of record business in this country, and confirms our statement of the first paragraph: When the San Remo songs appear released in Buenos Aires twenty four hours after the event, and in Spanish, it means that the business is swinging!

The advent of Global TV through the satellite system has also started to influence the record trade, as it could be expected, and it took by surprise some of the manufacturers. Only in May, several months after the start of the system, promotional uses of the device started to appear, with the airing of the Sandro concert at Madison Square Garden, in New York, and a concert by Los Fronterizos in Washington. Of course, there was also the San Remo airing, with the RCA operation already mentioned, but the case was somewhat different. The EVR technique will also change substantially all the known patterns on promotion, sales and talent, and we must hope that the industry will be prepared at that moment (1972?) to face it.

Tapes and cartridges, and mainly cassettes, which received a strong backing from Phonogram and afterwards by other manufacturers, who joined the movement, marked substantial sales for the first time; many developments in this field may be expected for the future, since the industry is rapidly building producing facilities, and on these days Music Hall is adding its new factory to the existing ones. The little availability of good playing equipment is still a strong

difficulty, solved partially by the use of cassette recorders as reproducers, which isn't the best way to listen to a cassette. In spite of these troubles, the cassette sales volume is expected to grow by ten fold, in the next three years, by some of the leading manufacturers.

Another factor of growing importance has been the increasing cost of promotion, due to the lack of a real cooperation between the manufacturers and radio stations and disk jockeys — the Top Forty station practically does not exist yet — the scarcity of musical programs on TV that would back recent releases and the little development of other means of promotion, like music festivals, contests and fan magazines and papers. In some cases, the festivals are handled on a non-competitive basis, resulting in artists singing standard tunes to get the biggest possible applause, instead of trying to plug new product. In others, the jury is oriented not on a pop or commercial basis, but on certain musical and artistic qualities, which result on prizes awarded to tunes lacking the necessary "feeling" as to appeal to the crowds. This and other problems are discussed in detail further, in the following paragraphs.

**THE MARKET.** The total volume of the industry showed a sharp increase during the second part of 1969, with a strong participation of local product, both in the pop and beat field, and a lowering in the proportion of imported songs, to a point where nearly 80% of the songs appearing in the Top Twenty charts were locally produced. After the peak Christmas sales, however, a downfall made everybody look serious, and February and March showed only fairly better results than January, which suffered from the lack of strong Summer hits. April, May and June looked somehow better, but nevertheless, most of the companies had difficulties to reach the budgeted

volumes, and cost-cutting ideas were being applied everywhere. The slowdown didn't affect investments, which continued strong, but created nervousness regarding new artists and trends, since it didn't appear clear as to what to do.

There could be many reasons for the slump: the main one could lay on the increased collection of taxes and the anti-inflationary measures taken by the government, which affected the terms of payment and, since the credit had to be maintained at the same level due to the increased investments in equipment and recordings facilities, sales were hurt. However, we feel that the main point is that the local recording movement, in 1969, had been based on locally-produced beat music, of certain quality. This resulted in the absence of new groups, that could develop a new sound in accordance with the new recording coming from abroad: only one exception appeared, the Trio Galleta, and it was successful covering artists like Creedence Clearwater Revival or Bill Deal and the Rhondells, but was unable to get a sound of its own.

Another fact that should be kept in mind is that the market is lacking new soloists, since those in the charts (Sandro, Palito Ortega) have been there for several years; no fresh influence has been noticed from new male soloists during these twelve months, and only one female soloist (Tormenta) has reached the Top Ten. This offered renewed possibilities to the foreign soloists singing in Spanish and sometimes even recording local products, but led to little activity in the Buenos Aires studios. This is a paradox in itself: although many recordings by chanters and songstresses are recorded or released every month, most of them don't have enough interest for the disk jockeys as to receive backing. This takes to diskeries to try more and more new waxings, with little better results, instead of

(Con't. on Page 66)

# FERMATA

Music Publishers

Record Producers



New Home:

Marcelo T. de Alvear

1573

New Phone: 44-5000

Cable: FermataBaires

BUENOS AIRES, ARGENTINA

# RCA ARGENTINA

## Presents Its New Artists with International "Punch"

		
<b>TORMENTA</b>		<b>DONALD</b>
	<b>CARLOS BISSO Y SU CONEXION No 5</b>	
<b>JUAN Y JUAN</b>	<small>THESE ARTISTS MAY BE CONTRACTED THROUGH US</small>	<b>TITO SADI</b>

# RELAY

Parana 236-52 Piso-Of. 13- T.E. 46-8702  
Buenos Aires — Argentina

### Presents 1970's hits

**MUCHACHO QUE VAS CANTANDO** (Palito Ortega)  
**CEBANDO MATE** (Tormenta)  
**PRETTY BELINDA** (Chris Andrews)  
**SERA ESTA LA ULTIMA VEZ** (J. Zeller—Ch. Levi)  
**QUE JE T'AIME** (Renard—Thibaut)  
**WONDERFUL WORLD BEAUTIFUL PEOPLE** (Jimmy Cliff)  
**COMPASION** (R. Rodriguez Rodway—L. Moreno Salguero)  
**MAH-NA, MAH-NA** (Piero Umiliani)  
**CHIQUILINA** (Franco—Valdez)  
**PROUD MARY** (John Fogerty)  
**MY CHERIE AMOUR** (S. Wonder—Cosby—Moy)  
**ABC** (The Corporation)

**DOWN ON THE CORNER** (John Fogerty)  
**SUGAR, SUGAR** (Barry—Kim)  
**TRAVELIN' BAND** (J. Fogerty)  
**SOY IGUAL A LOS DEMAS** (R. Narvaja)  
**LA PRIMA COSA BELLA** (N. Di Bari—Mogol)  
**COME HAI FATTO** (D. Modugno)  
**CHI NON LAVORA NON FA L'AMORE** (A. Celentano)  
**FACUNDO HA LLEGADO AL MUNDO** (C. Pueyrredon)  
**MUDDY RIVER** (J. Hendricks)  
**LOVE IS ALL** (Mason—Reed)  
**LOVE'S BEEN GOOD TO ME** (R. McKuen)  
**BALADA PARA UN GORDO** (Juan y Juan)

# ARGENTINA: The Past 12 Months

(Con't. from Page 64)

concentrating themselves in thinking what could be the gimmick to reach the desired results. In the meantime, the foreign records flourish . . . and have reached nearly 70% of the Top Twenty posts, starting from the modest 20% they had less than one year ago. The record executive in despair will often look at the foreign charts, choose the best-looking items, and release them, as a way to survival. Of course, this won't bring prosperity to an industry based already on a strong percentage of local product, and opening new recording studios and pressing plants every year.

Prices haven't increased as much as in the previous years, due to the already mentioned Government plans to fight inflation. Regular LP's sell for about \$4 to \$4.30, promotional albums—in most cases carrying a selection of the current hits on singles marketed by the diskery at the time—sell for about \$2.80, and budget priced record go from a low of \$1.40 to an average of \$2; many regular LP's after some time in the high priced category, are labeled under one of the budget collections, even with the same package, and priced at \$2. In other cases—folk music from other countries, Classical music—they are directly oriented to this branch of the catalog. Some labels maintain also an intermediate level, also at \$2.80, but with a different policy from the one used with the "promotional" albums. Since single prices are at the \$1.10 to \$1.20 level, it is easy to see that budget albums compete directly with them, and that there is little room left for EP's or Compact 33's, a format that seems to work only for certain artists and kiddie music. It is important to note that the quality of records themselves is mostly the same in the budget, promo and regular albums, and that many dealers practice a "budgeting" policy of their own, buying big quantities of records retired from

catalogs and selling them for as little as \$.60.

The main problem for cassettes and cartridges is their price: they range from nearly \$7 in the best of cases to \$9 for those cassettes that are wholly imported. This originates a problem with the customers that buy blank cassettes for as little as \$2 and \$3, and afterwards copy from records. Of course, nothing can be done, but it will be in the interest of the industry to lower prices as to reach a comparable level with records. No counterfeiting has been noticed up to the moment.

Records clubs and discounts aren't very popular now, due to the increase on production costs (and retail); this happens after several years during which it seemed that clubs would gather a good share of the market. As a matter of fact, the practice has been discouraged by the same companies, and gladly accepted by the retailers. One stops or "wholesalers", as they are called here have been gaining force, simply by the fact that they can operate on special discounts offered by the diskeries—partly justified by the volume of purchase, partly by the willingness of sales managers to build a volume and fulfil the budget—and that they offer to small shops the advantage of only one account instead of ten, and faster service in many cases. There are five "wholesalers," and they account for 50% or more of the whole business in some places. The total of sales points may be estimated in 1400, but only 700 of them is important. Supermarkets, having entered the business in the past three years, are also handled in many cases by these wholesalers. As we have mentioned in this column before, the Chamber of Record Producers keeps in secret the actual sales figures, in a decision that has been frequently and severely criticized by the press and even by members of the own Chamber; however, a \$3 million monthly figure could be guessed as correct, not counting special prod-

ucts or projects handled by The Readers Digest and others. The sales volume is, as already noted, limited by the distribution system, which has been suffocating the industry for many years; racks haven't been very successful yet and the production has to be channeled through the usual ways, except in the case of Microfon, discussed later.

**PUBLISHERS.** Times are hard, and they seem to be looking the same for the future, unless a change in the collecting society, SADAIC, happens soon. The main trouble is that there is a delay of many months between the actual happening of the hit and the receipt of the performance money; in some cases, it has amounted to about two years. It can be imagined that it is difficult to invest a strong initial payment in a song, when you expect to recover the money, if you ever do, after three years. Thus, it is easier to concentrate on those tunes that depend on mechanical rights (records) which are paid sooner. In some cases, small companies are even avoiding SADAIC copyrighted tunes, favoring ghost composers or BIEM. A few months ago, a long lasting crisis was apparently solved by the election of Ariel Ramirez as president of the society; in the next months, it will be seen if Ramirez is able to obtain results and improve the collection system, which has been severely discussed in the past. As a point of irony, the composers having their money retained by SADAIC are able to obtain loans, from the society, at a very low interest.

Another matter of change is that, since the composers' royalty amounts to 4% per side, in most cases the artist will earn more money for the hit record (if he composes both tunes) as an author than for his performance. This has created a whole generation of singers-composers, and, consequently, a trend among the diskeries to form their own pubbery and try to control

the catalogs most used in the recordings; as a second step, they seek the catalogs used by other diskeries. As a result, the traditional have to limit their operation and expand only very cautiously, merge with a record company or start to produce records by themselves. All the three things have happened here, and it is commented in each case in detail.

If the artist considers to be sufficiently strong as to create a catalog by himself, with the aid of other composers or alone, we have the third possibility. Of course, the existence of these pubberies may be limited to the career of the artist, but the group of songs may be always sold to some other organization, and the cost of maintaining a publishing outfit is rather low; no pubbery of this sort has closed till now.

As before, the percentage allowed to the pubbery on the composer's rights is only 25, against the usual international standard of 50 or, at least 33%. This is reflected on little investment on the tune from the pub-

lisher, and puts this branch of the industry in the position of an appendix of the record companies. The low performance rights from TV and radio stations, and the existence of few music spots (apart from the Carnival dance parties, a seasonal phenomenon) where performance royalties could be collected in big scale, have marked the decline, as a whole, of the publishing industry as an independent institution, like it was ten or twenty years ago.

**PROMOTION.** The situation has changed little during the past 12 months. We may recall that there are 16 radio stations in Buenos Aires, about 50 more in the rest of the country (the biggest cities, Cordoba, Rosario and Mendoza, have although in a commercial way and allowing them to run

(Con't. on Page 68)

## THE TOP POP LATIN AMERICAN SONGS

Rosa Rosa — Una Muchacha y Una Guitarra —  
Tengo — Guitarras al Viento — Asi — Penumbras — Trigo — Penas — Se Te Nota — La Vida Continua — Sin Sentido — Tiempo Feliz — El Maniqui — Elisa — Cuando Existe Tanto Amor — Senor Cocho — Dame — Dos Solitarios — Por Algun Camino — Hey Hey — La Causa de Este Amor — Existe Una Razon — Te Quiero Tanto Amada Mia

**ARE ORIGINAL COPYRIGHTS**

By

**A.N.S.A. PUBLISHERS**

FROM ARGENTINA

## OSCAR ANDERLE & ASOCIADOS

A complete artist  
management service

**SANDRO**

**ESTELA RAVAL**

**PALOLO**

Records — TV — Cinema  
Personal Appearances

**EDITORIAL MUSICAL ANSA OSCAR ANDERLE & ASOCIADOS**

S.C.

14 TUCUMAN 1455 — BUENOS AIRES — ARGENTINA

**SOMETIMES  
WE WONDER  
WHY**

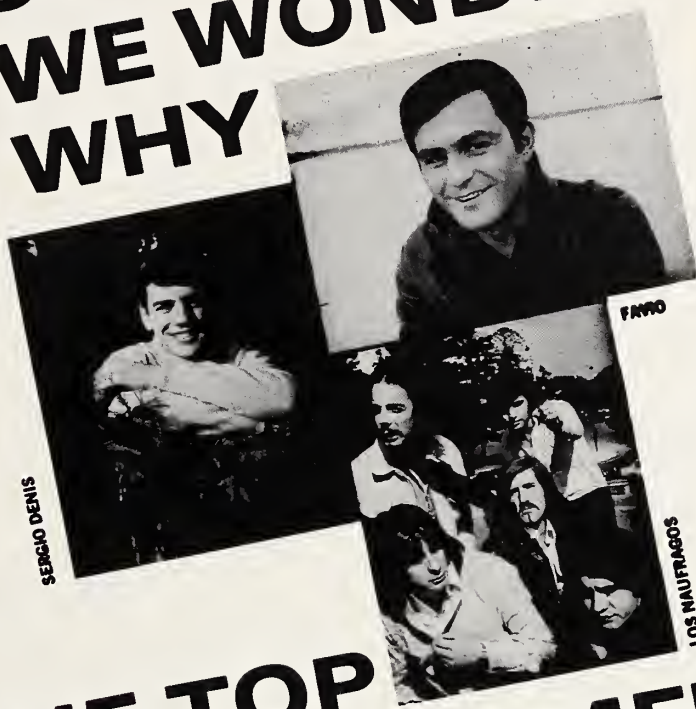

**ALL THE TOP  
LATIN AMERICAN  
ARTISTS**



**ARE  
WITH US!**

**DISCOS CBS S.A.  
ARGENTINA**

PARAGUAY 1583  
BUENOS AIRES





INDUSTRIAS  
ELECTRICAS Y MUSICALES

**ODEON**

S.A.I.C.

ARGENTINA

MANUFACTURES AND DISTRIBUTES  
LATIN AMERICA'S TOP HITS:

THE BEATLES	APPLE RECORDS
THE ROLLING STONES	LONDON
TOM JONES	LONDON
ENGELBERT HUMPERDINCK	LONDON
GLEN CAMPBELL	CAPITOL RECORDS
SALVATORE ADAMO	PATHE MARCONI
JOAN MANUEL SERRAT	ZAFIRO RECORDS

AND MANY, MANY OTHERS. . .

Mendoza 1660

Buenos Aires

ARGENTINA

## ARGENTINA: The Past 12 Months

(Con't. from Page 66)

independently during nearly 100% of the time. There is also an official network, Radio Nacional, which works mostly with folk, tango and Classical music, and does not count very much for pop music promotion. The number of TV channels is increasing steadily, but not in Buenos Aires, where there are five. Cordoba, Mendoza, Mar del Plata and Rosario have two channels each, and the total amounts to about forty. The programming is originated mostly in Buenos Aires, and aired through video tape. Special events allow for a direct connection between Buenos Aires, Mar del Plata, Rosario and Santa Fe, and in the future will link several other points, but this is not used very often because of the cost. The filming of short features, with a song by one or two artists, is a custom not too extended yet, due to the cost and limited possibilities for airing.

Music Festivals have been also increasing in amount and force, although from the promo viewpoint they are in most cases severely limited by their non-competitive nature (most of the top artists refuse to appear unless they are granted an award) or the criteria of selection, which is not sales-oriented. The two events which resulted in strong sales took place in November, and were the Festival Buenos Aires and a song contest organized by the City of Buenos Aires. As it usually happens, it wasn't the winning song, at both places, the one which afterwards reached top sales, but two of the losing finalists. The array of folk music shows that are placed in the

provinces during the summer season didn't result, as it was expected, in new names of commercial value. Last April, Channel 13 of Buenos Aires started, with the cooperation of four of the major labels, a song contest, which hasn't yet finished.

**ARTISTS.** As we mentioned before, no leading artists have appeared during this period, although some of the old names have lost their attraction, resulting a lack of top artists that has had to be filled with foreign names. As it has always happened, there are no barriers for singers and groups of other countries and their performances, and the Carnival dance parties are the best season for them, due to the high fees that are paid for each 25 minute performance.

In the soloist field, Sandro has been the number one, with a strong attraction not only in Argentina but also in the rest of the Latin American markets, and in the Spanish-speaking parts of the United States, where he appeared at the Madison Square Garden. Palito Ortega didn't shine as high as during the previous years, but nevertheless stays at the top level and his TV appearances have obtained a 23 plus points rating, on Channel 13. Leonardo Favio rated under his performance of the previous period, but still appeared consistently among the top sellers. Carlos Javier Beltran, a newcomer, got good sales, as did chanter Piero, who returned to the scene after several years of absence with two strong sellers. Among the girls, only Tormenta a newcomer, deserved strong attention. There are at least two good duets, Fedra y Maxi-

(Con't. on Page 70)

## GERMANY: The Past 12 Mos.

(Con't. from Page 63)

which will represent all Deutsche Grammophon labels and Liberty/UA artists . . . "MPS-classic-serie" and "Session," two new labels which were taken over by MPS . . . The generally known American music publishing concern Chappell is no longer represented by the August Seith music publishing houses in Munich. The new German publication manager Dr. Michael Mueller-Blattan opened a Chappell office in Hamburg . . . As first German firm Phonogram Ton, Hamburg, published double MusiCassetts with more than 80 minutes music which are 10 DM (approx. 3 dollars) cheaper than the normal two ones . . . AEG Telefunken-Decca, Berlin, demonstrated a new video-store system . . . Peter Kirsten founded beside his firms Global-Musik, Fanfare and Altus the Fund of Music company which is for distribution of background music for all purposes. The record office includes more than 25,000 titles also from American and English firms.

In Munich the 19th International Music Competition of the Gernar broadcasting stations will take place from the 1st till 18th of September 1970. The competition, among artists from all over the world, will feature vocal music, piano, harpsichord, flute and string quartet participants. For more detailed information, write: Internationaler Muikwettbewerb, 8 Muenchen 2, Bayerischer Rundfunk. Last period for registration is on July 1, 1970 . . . In Germany the MusiCassetts business gets more and more important. As a computer has calculated, in 1973/74 the sales will assimilate to the sales of LP's. Till 1972 the cassette sales shall run to more than 17 millions. Therefore in the future a rapid upward movement on the tape deck and cassette sector can surely be expected. It is prophesized that before the end of this decade 40-50% of the total turnover will be made on the sector of MusiCassetts . . . Seven North European countries has planned to hold off in the beginning of August a pop-in on the Isle of Helgoland in the North Sea. Participants are Germany, Holland, Belgium, Great Britain, Denmark, Norway and Sweden. The programs then would be broadcast daily over several stations. First class beat groups from all participating countries will take

part. The pop-in will end on the 15th of August with a three hour show, with all countries taking part . . . On the 4th of July, the supertour of Udo Juergens will be finished. This tour runs over ten month and includes 222 concerts. It is the biggest concert tour, which ever has been made in the whole world . . . Rudi Slezak, managing director of the music publishing companies controlled by the Robert Stigwood Organisation Ltd. since 1967, has decided not to renew his agreement with the Stigwood Organisation. The first foreign companies to be represented by Rudolf Slezak Musikverlag were Dratleaf Limited and Abigail Music (London) . . . The Rolling Stones concerts are scheduled for the 18th of September in Cologne, 20th in Berlin, 22nd in Hamburg, 24th in Munich and in the beginning of October in Frankfurt and Essen . . . Another festival of 100,000 in Hamburg and Berlin is planned by the German organizers Hans-Werner Funke and Lippmann Rau after the example of the big festivals in Woodstock and of the Isle of Wight in autumn. It will become a supermeeting of leading English and American pop groups. Scheduled dates are the 30th of August in Berlin and the 4th of September in Hamburg . . . The German trade looks good in the future. They are sure that in the face of MusiCassetts and the coming video cassetts the record turnover — especially on the LP sector — will increase. During a stay in Germany Cash Box president George Albert briefly discussed the German market situation as follows:

"The German market, like every other market, has developed and increased in the past 15 years since we originally in Cash Box had started the international complex of the world. As a trade publication we have been the pioneers in development of creative material for the whole world. Germany has been the first market which has developed to such a great degree and expand so that it became one of the major markets of the entire world. Their materials have been expanded to all the other major markets. They have changed; they have imported, exported and they have created and been a tremendous contribution to the music and the entertainment world through their continual growth in this market."

# THANK YOU!

For having placed your catalogs in our care and thereby made possible our rapid development.

Suppliers (Sudamérica)

**THE YOUNGEST RECORD COMPANY IN ARGENTINA**

WRITE OR CABLE US: MENDOZA 1660 - BUENOS AIRES - CABLE: TURNTABLE



# PALITO ORTEGA GOES INTERNATIONAL!

His New LP Recorded  
in London and Rome:

HIS NEW LP  
RECORDED IN  
LONDON AND  
ROME:

"Me Quedé Llorando"

"Muchacho que vas  
Cantando"

"Tomando un Cafe  
Hablamos de Amor"

"Te Quiero, Amor, Te  
Quiero"

"El Rebelde Con su  
Causa"

"Tu Eres Mi Unica  
Ilusion"

"Te Deseo Buen Viaja"

"Un Dia de Invierno"

"El Amor es una Canción  
Que No Deja de Sonar"

"Que Los Quince Los  
Cumplas Muy Feliz"

"Corazon de Algodón"

"Hola"

  
Hit Songs  
Published  
by  
**Clanort**

Tucuman 1455  
Buenos Aires  
Argentina  
Cable: Clanort  
Baires

# MICROFON

The leader in budget records  
of Argentina

introduces

## EDIFON s.r.l.

The newest and most dynamic  
publishers of Latin America

We are interested in record  
and publishing catalogs  
from the U.S. and Europe



### MICROFON ARGENTINA

s.r.l.

Sarmiento 1983  
Buenos Aires  
Argentina

## ARGENTINA'S MUSIC PUBLISHERS

**EDICIONES MUSICALES KORN**  
Belgrano 1478, Buenos Aires  
Tel: 37-5061

**EDITORIAL ODEON**  
Manager: M.C. Hajdenwurcel  
Corrientes 485, Buenos Aires  
Tel: 46-0751

**EDITORIAL EDAMI**  
Manager: A. Crotogini  
Lavalle 1494, Buenos Aires  
Tel: 1494, Buenos Aires  
Tel: 40-8853

**ESTABLECIMIENTO MUSICAL NEUMANN SRL**  
Manager: Carlos Di Liscia  
Maipu 235, Buenos Aires  
Tel: 46-5343

**EDITORIAL LAGOS**  
Manager: Romulo Lagos  
Talcahuano 638, Buenos Aires  
Tel: 40-3746

**EDICIONES INTERNACIONALES FERMATA**  
Marcelo T de Alvear 1573, Buenos Aires  
Manager: Mauricio Brenner

**LYFSA**  
Diag. R. S. Pena 628, Buenos Aires  
Manager: Leonard Favio

**EDITORIAL CLANORT**  
Tucuman 1455, Buenos Aires  
Manager: Carlos Oliveira

**EDIFON SRL**  
Sarmiento 1983, Buenos Aires  
Manager: Norberto Kaminsky

**EDICIONES MUSICALES RELAY**  
Manager: Beatriz Lupo  
Parana 236, Buenos Aires  
Tel: 46-8702

**MILROM SRL**  
Manager: Lucio Milena  
Moreno 970, Buenos Aires

**SMART EDICIONES MUSICALES**  
Manager: Romiglio Giacompol  
Santa Fe 1552, Buenos Aires  
Tel: 44-5796

**EDITORIAL ANSA**  
Manager: Oscar Anderle  
Tucuman 1455, Buenos Aires

**MELOGRAF**  
Charcas 1422, Buenos Aires  
Tel: 422867  
Manager: Buddy McCluskey

### ARGENTINA: Past 12 Mos.

(Con't. from Page 68)

miliano (with several entries) and beat duet **Juan y Juan**, breaking into the charts lately with a single and seeming to have a good potential for 1970.

Beat groups held the greatest slice of the market, and many of them reached the Top Twenty and appear among the top sellers of the year. Some of the names are **Los Naufragos**, **La Joven Guardia**, **Los Gatos**, **Almendra**, **Manal**, **Los Walkers**, **Trocha Angosta**, **Pintura Fresca**, **Septima Brigada**, **Piel Tierna**, **Carlos Bisso** y **Conexion Numero Cinco**, and others, ranging from a straight approach with a language much alike the slang used in Buenos Aires to experiments in psychedelia.

As a whole, however, it is interesting to mention that the individual force of the artists decreased during these twelve months, to the point where most of the top selling albums in May and June 1970 were formed with a selection of the hit tune by each of these artists, rather than by twelve songs by one artist or group.

From the foreign visitors, the biggest hit was undoubtedly Spanish chanter **Juan Manuel Serrat**, who produced an explosion with his tunes and was forced to return a couple of months after his first appearance and schedule several others for the near future. Two LP's and several singles headed the way to the charts, and there is big interest towards the new production by this artist. Spanish chanter **Dyango** obtained also a very strong success, via personal appearances and through a selected way of recording tunes suitable for this market. Another top name from Spain, **Raphael**, also sold very well after some time of unavailability of his records because of his lawsuit against **Hispavox**, which finally won it. Italian artists like **Nicola De Bari**, **Jimmy Fontana**, **Gabriella Ferri**, **Nada** and **Sergio Endrigo** have been also very popular, and the same may be said about **Gianni Morandi**, **Lucio Dalla** and **Rita Pavone**. From the Latin area, the leading artist has been Venezuelan chantress **Mirtha Perez**, and one more Spanish artist: flamenco star **Peret**.

As for American and British artists, the biggest sellers have been **Johnny Rivers**, **Creedence Clearwater Revival**, **Bill Deal** and **The Rhondells**, **Led Zepelin** and of course **The Beatles** and **The Rolling Stones**. Soul artists like **Aretha Franklin**, **Wilson Pickett** and **Otis Redding** also ranked high, with steady but consistent popularity; **Herb Alpert** and his **Tijuana Brass** had a good comeback after his **Singer Special** was aired on TV.

How much did a hit mean? During these twelve months, top smashes could reach the 150,000 mark, both in the singles and LP field. Good regular hits averaged between 80,000 and 110,000, and a "strong" record should not sell less than 50,000. For LP's, figures could be a 20%. Resulting artist fees for TV and public performances can amount to \$1,000 for top artists and hits, \$500 to \$800 after or before the

summit. In general, top artists are avoiding TV exposure, and a good example is set by **Palito Ortega**: he usually appears on television about twelve times a year, stars on two or three spectaculars, and does only one appearance in person in the year, generally during Carnival. For the interior of the country he arranges a tour that lasts two months, once a year. Other groups like **Los Iracundos** prefer to spend most of the time in the interior, and usually do not appear on TV at all. The same applies to those with a strong disk image, who try to avoid the cameras.

### THE TRADE

**CBS RECORDS** — The company enjoyed record sales through the smashes by solo chanter **Sandro**, with titles like "Asi", "Penumbra" and "Se Te Nota", and two LP's, beat music group **Los Naufragos**: "Zapatos Rotos", "Yo on Mi Casa, Ella en el Bar." **Leonardo Favio** and folk artists **Jorge Cafrune** and **Roberto Rimoldi Fraga**. In April the company stopped its production plant to allow the building of new facilities. The launching of the new (for Argentina) label **Epic**, under the management of **Douglas Taylor**, marked the development of new markets for the diskery, along with the increase of releases under the **Harmony** low-priced logo. **Harold Morris** named **John Lear** as general manager, **Roberto Aguado** as commercial manager and **Hugo Piombi** as top A&R man in November, as part of a revamping of the diskery. The policy of the label was to intensify local releases, counting on producers **Techeiro**, **Figuerola Reyes** and **Francis Smith**, responsible for many hits.

**DISC JOCKEY** — The **Rodriguez Luque**-directed diskery based its operation mainly on the exploitation of the French **Barclay**, Spanish **Vergara** and British **Major-Minor** labels, and the marketing of beat music groups and soloists as **Pintura Fresca** and **Carlos Javier Beltran**. There is also a regional music branch, designed for the markets of the interior, sometimes with a cover of International hits with a local flavor, and also an eye on the melodic music market through artists like Chilean top seller **Rosamel Araya** and local star **Pepito Perez**. One of the biggest hits of the season was **Peret**, who came to Buenos Aires for appearances at the **Mau Mau** discotheque in April.

**EMI SUPPLIERS** — The newest big diskery in Argentina, it was originated by a decision of **Odeon** — the **EMI** Ltd representative in this country — to open a branch that would operate independently with the labels that **Odeon** was unable to service at its best in this country. Starting from nothing less than three years ago, the **Juan Carlos Menna**-directed diskery has reached a 10% share of the market, expanding itself into other markets like poetry, jazz and distribution of other labels. The latest acquisition was the representation of **Belter**, which folded as an indie after several years of struggling; **Dunhill**, previ-

(Con't. on next page)

### A ROSTER OF INTERNATIONAL CHART BREAKING ARTISTS:

Mirtha Perez  
Los Walkers  
Trocha Angosta  
Trio Rubi  
Banana

Barra de Chocolate  
Elizabeth  
Daniel Toro  
Luz de Mercurio  
Hernando

NEW RECORDING STUDIOS  
A COMPLETE PUBLISHING SERVICE:  
PAMSCO

## MUSIC HALL

Jose E. Uriburu 40  
Buenos Aires  
Argentina

# ARGENTINA'S RECORD COMPANIES

**DISC JOCKEY SAIC**  
Pedro Goyena 72, Buenos Aires.  
Tel: 92-9090  
Manager: Manuel Rodríguez Luque  
Labels: Barclay, Major Minor, Disc Jockey

**DIAL SRL**  
Pasteur 341, Buenos Aires. Tel: 470145  
Manager: Carlos Tealdo Alizieri  
Labels: Dial, Fantasy

**DISCOS CBS SA**  
Paraguay 1583, Buenos Aires.  
Tel: 422616  
Manager: Harold Morris  
Labels: CBS, Epic, Elektra

**FAMOUS SRL**  
Manager: Ian Morris  
Venezuela 4131, Buenos Aires  
Tel: 93-2651  
Labels: Ariel, Musidisc,

**EMI SUPPLIERS**  
Mendoza 1660, Buenos Aires  
Tel: 73-0051  
Manager: Juan Carlos Menna  
Labels: Parlophone, United Artists,  
Vogue, Liberty, Dunhill, Apple

**INDUSTRIAS ELECTRICAS Y  
MUSICALES ODEON SA**  
Mendoza 1660, Buenos Aires.  
Tel: 73-0051  
Manager: A. Campbell  
Labels: Odeon, Capitol

**MANDIOCA**  
Tucuman 1506, Buenos Aires.  
Tel: 46-6468  
Manager: Jorge Alvarez

**MICROFON ARGENTINA SRL**  
Sarmiento 1983, Buenos Aires  
Tel: 45-4797  
Manager: Mario Kaminsky  
Labels: Chesec, Checker, Cadet,  
Microfon, Audio Fidelity

## ARGENTINA: Past 12 Mos.

(Con't. from preceding page)

ously represented by RCA, was also acquired during this period.

**FERMATA PRODUCTIONS** — The main effort of the diskery was the moving to a four-story building, out from its old offices on San Martín Street, and the huge investment required to relocate all the publishing and record-distributing facilities. The year was devoted to an increase of local recordings, involving the contracting of local pop and Classical music talent like *Las Trillizas de Oro*, the *Melos Ensemble* of Buenos Aires, poet-singer *Anzoategui*, chanter *Ricardo Ceratto* and others. The international connections were improved through several trips to the States and Europe paid by *Lebendiger* from Brazil, which put *Fermata* on a competitive basis for all the changes in the International scene that have been taking place during the recent past.

**MICROFON** — The diskery changed somewhat his policy of previous years, orienting itself towards the budget market and its unexploited possibilities, ranging from tie-ins with magazines to direct mail selling. The company moved to new headquarters, on Sarmiento 1983, and revamped its organization, starting new series and relabeling part of its product, with excellent results and a strengthening of its position in the market, without depending too much on a single chart hit. The contracting of radio emcee *Julio Marbiz* folk music producer brought in artists like *Los Quilla Huasi* and *Los Huanca Hua*, and helped to better use the talent of names like *Chacho Santa Cruz*. On the tango side the diskery's main artist is *Virginia Luque*, whose LP devoted to *Enrique Santos Discepolo* sold very well.

**ODEON** — The diskery has one of the biggest hits of the year in Spanish chanter *Joan Manuel Serrat*, and also profited from the strong sales obtained by nearly all the *Beatles* and *Rolling Stones* recordings released and mainly the albums "Abbey Road" and "Pentagon," which appeared among the top attractions of the year. In the local field there were good

**PHONOGRAM SAIC**  
Moreno 2038, Buenos Aires  
Tel: 48-5524  
Manager: Hugo Persichini  
Labels: Philips, Polydor, Disneyland,  
Archiv DGG, Atlantic

**PRODISA**  
Culpina 375, Buenos Aires  
Tel: 611-4819  
Manager: Jorge Esperon  
Labels: Tonodisc, Westminster, ABC,  
Command, Impulse!

**TROVA**  
Corrientes 2434, Buenos Aires.  
Tel: 47-9996  
Manager: Alfredo Radoszynski  
Labels: Trova, Elenco, Scepter, Folkways

**SURCO IND MUSICALES**  
Tucuman 439, Buenos Aires.  
Tel: 32-3143  
Manager: E. Iriberry  
Label: Opus, Telefunken

**SICAMERICANA SACIFI**  
President: Nestro Selasco  
VP: Luis Calvo  
J.E. Uriburu 40. Tel: 46-9308  
Labels: Music Hall, Warner Bros, Dot,  
Musart, Pye, Durium.

**RCA**  
Paroissien 3960, Buenos Aires  
Tel: 70-4171  
Manager: Adolfo Pino  
Labels: RCA, Vik, Tamla-Motown, Groove

**PRODUCCIONES FERMATA**  
Marcelo T. de Alvear 1573  
Tel: 44-5000  
Manager: Mauricio Brenner  
Labels: Fermata, PDU, Ranwood, RGE

results with *Trio Galleta*, folk chanter *Coco Diaz*, tropical music group *Los Wamanco* and, of course, the large catalog of standard tango music, which includes *Carlos Gardel* and other big stars, and the folk music albums recorded by *Atahualpa Yupanqui* and others. The appointing of *Denis Dunn* as Top A&R man brought new strength to the chart action of the label, and an increase in the market share held by it.

**PHONOGRAM** — The hit of the season, from the point of view of the charts, and mainly in the first months of 1970, when a string of smashes allowed the three main labels distributed by Phonogram (Philips, Polydor and Atlantic) to invade the Top Twenty, pushed by a dynamic indie producer organization and a fresh approach to the handling of young artists like *Elio Rocam* that had been already with the label for several years but never at their full potential. In the folk music field, the naming of *Cesar Isella* as man in charge of developing new talent brought also good results. The company has also pioneered cassettes and improved substantially its distributing and recordings facilities, and will start building new studios next year, in its own building, which is prepared for this. The acquisition of *Korn Publishers* brought the necessary backing and allowed to combine efforts in both fields and improve results. One of the leaders in the export of local music, through the Philips and DGG organizations in Europe, where several recent recordings by *Ariel Ramirez* and other artists have been released.

**PRODISA** — A diskery oriented mainly to the big sound and orchestra recordings, has been also profiting from the increase in cassette and cartridge sales, and a steady development in the stereo music market, where *Prodisa* is strongly represented through the *Command*, *Project Three* and *Monument* catalogs. *Jorge Cesar Esperon*, its manager, has been operating on the basis of luxury-printed jackets and unmatchable pressing, and has been able to obtain both good sales on certain singles (like *Tommy Roe*) and albums of permanent value.

**RCA** — The most aggressive attitude in the whole industry, battling always

(Con't. on Page 73)

# PHONOGRAM

s.a.i.c.

PRESENTS  
THE BEST ARTISTS  
IN ALL FIELDS OF MUSIC  
THROUGH ITS LABELS

## PHILIPS - POLYDOR

Los Fronterizos	Gasparin y su Conjunto
Eduardo Falu	Conjunto Maracangalha
Ariel Ramirez	Nelida Lobato
Mercedes Sosa	Elio Roca
Jaime Torres	King Clave
Julia Elena Davalos	Miguel Angel, "El Mochilero"
Horacio Guarany	Eduardo Lavaque
Luis Landriscina	Sergio Villar con Industria
Cesar Isella	Argentina
Transito Cocomarola	Gringo
Duo Salteño	Pete Senegal
Los Tucu Tucu	Piel Tierna
Los Cantores del Alba	Extraña Dimension
Ernesto Montiel	Maria y Federico
Raul Barboza	Clase '49
Gabino Correa	Lechuga
Cantares de la Cañadita	Romulo y Remo
Las Voces del Plumerillo	Oswaldo Pugliese
Anteojito	Oswaldo Piro
Hijitus	Horacio Salgan
Topo Gigio	Edmundo Rivero
Andre y su Conjunto	Horacio Deval
Vincent Morocco and Orchestra	Roberto Achaval
Jean Pierre	Donato Racciatti
Studio A Orchestra	Cuarteto Los Portenitos

# PHONOGRAM

s.a.i.c.

## RECORD PRODUCERS

Philips — Polydor — Atlantic  
Verve — M.G.M. — Mercury  
Disneyland — Buddah — Kama Sutra  
D.D.G. — Archive — Fontana — Heliodor

**MORENO 2038**

**BUENOS AIRES — ARGENTINA**

# ARGENTINA'S BEST SELLERS DURING THE PAST 12 MONTHS

## CBS RECORDS

### SINGLES

Trigal  
Balada Para un Loco  
Zapatos Rotos  
Me Has Ensenado a Conocer  
Te Llamo Para Despedirme  
Mi Viejo  
Penumbra  
Cuéntame  
Duelo en el Canon del Diablo  
Argentino hasta la Muerte

Sandro  
Amelita Baltar  
Los Naufragos  
Luis Aguilé  
Sergio Denis  
Piero  
Sandro  
Fedra y Max  
Grupo Uno  
Roberto R. Fraga

### LP's

Sandro de America  
Sandro  
Fuiste Mia un Verano  
Festival de Exitos  
El Tigre  
Juguemos en el Mundo  
Les Chansons pour Toi  
Festival San Remo 69  
Con Sabor a Colombia  
Presenta los Exitos

Sandro  
Sandro  
Leonardo Favio  
Selection  
Roberto Rimoldi Fraga  
Maria Elena Walsh  
Caravelli  
Selection  
Cuarteto Imperial  
Lafayette

## DISC JOCKEY RECORDS

### SINGLES

Es Preferible  
Ayer Aun  
El Amor es Todo  
Looky Looky  
Camino a San Francisco  
Paco Camorra  
El Baile de la Sepriente  
Faltan Cinco Pa las Doce  
El Abuelo

Peret  
Carlos Javier Beltran  
Malcolm Roberts  
Pintura Fresca  
Freddy Solo  
Septima Brigada  
Rama  
Pepito Perez  
Luis Medina Castro

### LP's

Pintura Fresca  
Es Preferible  
Malcolm Roberts  
Carlos J. Beltran  
A. Bailar  
Rosamel Araya  
Lo Mejor  
Pepito Perez  
Guillermo Neira  
Guitarras de Oro

Pintura Fresca  
Peret  
Malcolm Roberts  
Carlos Javier Beltran  
Rama  
Rosamel Araya  
Charles Aznavour  
Pepito Perez  
Guillermo Neira  
Las Guitarras de Oro



## CARLOS JAVIER BELTRAN

The new  
melodic voice  
of  
Latin America  
records exclusively on

## DISC JOCKEY RECORDS

PEDRO GOYENA 72 — BUENOS AIRES — ARGENTINA

## EMI SUPPLIERS

### Singles

Proud Mary  
La Nave del Olvido  
Down the Corner  
Hace una Larga Angustia  
Goodbye  
Travelin' Band  
When the Moon Rises  
Give Peace a Chance  
Muddy River  
Casatschock

Creedence Clearwater Revival  
Greco  
Creedence Clearwater Revival  
Roberto Vicario  
Mary Hopkin  
Creedence Clearwater Revival  
Creedence Clearwater Revival  
Plastic Ono Band  
Johnny Rivers  
K. Ramazov

### LP's

Live Again  
Bayou Country  
Willy and the Poorboys  
Green River  
Muddy River  
Beat of the Brass  
Hace una Larga Angustia  
Butch Cassidy  
A group Called Smith  
Fool on the Hill

Johnny Rivers  
Creedence Clearwater Revival  
Creedence Clearwater Revival  
Creedence Clearwater Revival  
Johnny Rivers  
Herb Alpert & Tijuana Brass  
Roberto Vicario  
Soundtrack  
Smith  
Sergio Mendes

## ODEON

### Singles

Tu Nombre Me Sabe a Hierba  
I've Been Hurt  
Fiesta  
Get Back  
Dejame Mirarte  
Ballad of John and Yoko  
Mama  
Come Together  
El mimoso esta alunado  
Green River

Joan Manuel Serrat  
Trio Galleta  
Joan Manuel Serrat  
Beatles  
Blue Caps  
Beatles  
Danielito  
Beatles  
Coco Diaz  
Trio Galleta

### LP's

Joan Manuel Serrat  
Abbey Road  
Alguien Canto  
Dedicado a Machado  
La Burrata  
Beatles  
I've Been Hurt  
Yellow Submarine  
El Goloso  
Personalidad

Joan Manuel Serrat  
Beatles  
Matt Monro  
Joan Manuel Serrat  
Los Wawanco  
Beatles  
Trio Galleta  
Beatles  
Coco Diaz  
Tom Jones

## PHONOGRAM

### Singles

Venus  
I've Been Hurt  
Cuanto te Amo  
El Extranjero  
I Say A Little Prayer  
La Primera Cosa Bella  
El Loco Luis  
El Mochilero  
Nana Hey Hey Adios

Shocking Blue  
Bill Deal & Rhondells  
Johnny Hallyday  
Georges Moustaki  
Aretha Franklin  
Elio Roca  
Piel Tierna  
Miguel Angel, El Mochilero  
Extrana Dimension

### LP's

Serie Doble  
Misa Criolla  
Boom 70  
En Blanco y Negro  
Serie Doble  
En Lunfardo  
Topo Gigio  
El Gran Mauriat  
Mujeres Argentinas

Los Fronterizos  
Ariel Ramirez—Los Fronterizos—Jaime Torres  
Selection  
Selection  
Andre  
Edmundo Rivero  
Topo Gigio  
Paul Mauriat  
Ariel Ramirez—Mercedes Sosa

## RCA

### Singles

Tiritando  
Te Regalo Mis Ojos  
La Extrana de las Botas Rosas  
Lejos de los Ojos  
El Extranjero del Pelo Largo  
Zingara  
Puerto Montt  
Hace Frio Ya  
Sugar Sugar  
Gracias Mama

Donald  
Gabriella Ferri  
Joven Guardia  
Dyango  
Joven Guardia  
Nicola de Bari  
Los Iracundos  
Nada  
The Archies  
Palito Ortega

### LP's

Preferidos a la Luna  
El Sentir  
Sotano Beat  
Muchacho de Oro  
Los Iracundos  
Carlos Bisso y Conexion Cinco  
La Voz del Amor  
Tiritando  
El Gran Hugo Marcel  
El Polaco y Yo

Selection  
Jose Larralde  
Selection  
Palito Ortega  
Los Iracundos  
Carlos Bisso y Conexion Cinco  
Dyango  
Donald  
Hugo Marcel  
Troilo/Goyeneche

## THE NEW CENTER OF INTERNATIONAL HIT SONGS

# MELOGRAF

(CBS Publishing Company in Argentina)

For efficient service in Latin America contact:

**MELOGRAF — Marcelo T. de Alvear 1422  
Buenos Aires-Argentina**

Here are some of our best selling composers:

Francis Smith, Sandro, V. Anderle, Favio, Leo Dan, Luis Aguilé, Donald, Maria Elena Walsh, Alberto Cortez

# FRANCE: The Past 12 Months

**JUNE:** J. C. Michel came in No. 1 in LP charts. J. C. Michel is probably the biggest French LP seller. All during the year, his success will increase . . . A strike keeps on paralysing the ORTF: musicians boycott the French radio station over a matter of salary . . . At the same time, there are more and more talks about a ban from the radio stations over American and British records. Though never official this ban

will soon become obvious on at least two of the three leading radio-stations . . . Georges Moustaki still No. 1 on the singles scene closely followed by "Oh Happy Day" which is to become a smash hit . . . Also selling in large quantity, "Oh Lady Mary" which will eventually top the million mark in sales ("Oh Lady Mary" was released on an E.P.) . . . Jean-Jacques Tilche (at the time head-producer at Philips) comes back from a short trip to America where he met many record-business personalities . . . Another big hit Michel Polnareff and "Tous Les Bateaux, Tous Les Oiseaux" . . . Claude Tabet launches the new-look "Festival Of The Two Roses" in Antibes. Appearing at this festival: Peter Holm, Anne Vanderlove, Serge Lama, Nicole Croisille, Gilles Dreu . . . Pathe launches a new label Xenon, directed by Gerard Manset and Etienne Roda-Gil: first release a hit: "Chimene" by Rene Joly . . . The Beach Boys in Paris . . . CBS starts out its big summer contest under the label Pop-Music revolution. This contest will be run with the help of record retailers.

**JULY:** Philips preparing an intensive summer campaign. All the big names with Philips will participate . . . Polydor staging a Musicorama at the Olympia in Paris with Richie Havens as top

name . . . Still best sellers: "Oh Lady Mary" by D. A. Winter, "Le Meteque" by G. Moustaki, "I Want To Live" by the Aphrodite's Child and "Oh Happy Day" by the Edwin Hawkins Singers . . . First names for the Antibes Jazz

Festival revealed: Nina Simone, John Lee Hooker, Miles Davis, Oscar Peterson, Ella Fitzgerald . . . CBS getting Michel Fugain and Marcel Amont . . . On the professional side: things are moving a lot: Roger Ribeyre and Jean Georgeieff are leaving Vogue to set at their own promotion company. They will soon be replaced by Jean Peigne. Janine Gery about to leave Barclay to come back to Polydor where she will head with Jean Distinguin the promotion department. At Polydor Andre Poulain (international manager) leaves to join CBS. He is replaced by Pierre Sberro who has just come back from London. Still at Polydor, Monique Fay is leaving to join Decca in September as head of the promotion. With her she takes Michele Grelbin. Evelyn Baudry also leaving Polydor as well as (soon after) Nicole Hornez . . . La chambre syndicale des Editeurs de musique legere has voted: President of its bureau: Rolf Marbot (Semi) vice-president: Georges Roquieres (Chappell)

. . . Baboo, the publishing company headed by Alain Boublil celebrating its first anniversary.

**AUGUST:** As usual, everything closes down in France for the summer. Yet soon everybody will have to admit that records now sell over a large period of time: witnesses: all the big summer hits started to sell long before the summer:

Johnny Hallyday "Que Je T'Aime" Michel Polnareff "Tous Les Bateaux, Tous Les Oiseaux" - Georges Moustaki "Le Meteque" - Aphrodite's Child "I Want To Live" - Edwin Hawkins Singers "Oh Happy Day" . . . The case of the summer hit seems dead.

**SEPTEMBER:** Philips holding its annual convention at the Hilton Hotel in Paris: From 1953 till 1969, the annual turnover has been multiplied by 14. Biggest aim: multiply its annual turnover between 1953 and 1973 by 20. Looks like they are going to make it . . . Claude Pascal who started recently his own music publishing company, started out with two hits: "Love Maestro

(Cont. on next page)

## ARGENTINA: Past 12 Months

(Cont. from Page 71)

for the first place in the charts and developing TV, radio and newspaper promotion through a fast moving advertising dept. headed by Carlos Garbarino. Adolfo Pino, in charge of the general management, increased action in the publishing field, through the Relay affiliated outlet, headed by Beatriz Lupo, and opened the way into artists management in May, under the direction of Charlie Levy Leroy. Top country artists like Los Iracundos, folk stars like Jose Larralde and Los Charchaleros, and active moving in the tango field through Aquiles Giacometti. The diskery re-opened the trend towards selection albums and launched the block release technique, marketing ten LP's at the same time under a strong advertising campaign. The handling of the MCA, Groove, Tamla-Motown and Jubille catalogs gave also several strong sellers, and among them The Cuff Links, Sam Shay and others.

**SICAMERICANA** — Operating in the budget and medium price fields, with the biggest collection of Classical music and folk standards selling for about \$2.20, on a large scale. Present in the charts through the Hispavox star Raphael, locally recorded Venezuelan star Mirtha Perez, several beat groups and artists from the States under the Reprise label and from Britain under Pye. Opened recently a cassette and cartridge producing factory, new studios and importing new and up-to-date equipment for these facilities. Expansion plans include new stories for its building, and the acquisition of more representation rights. Also working hard on the export of locally-produced music to other Latin American and Spanish-speaking countries.

**INDEPENDENT RECORD PRODUCERS** — The biggest and most important of them is Ricardo Kleiman, one of the top disk jockeys of the country, who a few years ago decided to get into the business and has now been producing deals with several labels, a publishing outfit and an artist managing agency. Kleiman's hits are based on the cover of American and European hits and on the deep observation of the likes and dislikes of the Argentine teenagers; the records usually apply the current slang words most used by the youth and the tunes, in most of the cases especially composed (if local) have even obtained string success in other countries and have been translated to English and French.

Litto Nebbia is also an example of the young chanter and composer who believes in a certain sort of music; after starting several years ago with the Los Gatos Group, credited with several golden records, he started a career as a soloist, then joined once more the Los Gatos Group, which had travelled to the States, and now produces their records and also other groups like Los Mentales, besides writing and singing his own production.

Palito Ortega, who started as a singer and author, has been able to develop a whole entertainment complex, with his own pubbery, a record producing outfit and an artist managing agency, with plenty of international action. He also writes and produces his own TV shows, and has been one of the main factors in the success of artists like Los Tios Queridos and Freddy Tadeo. Has also built a career as cinema actor, and plans to enter the European market in the near future, taking part at several song festivals and having his songs translated to English, French and German.

**disc**

**IS BURNING UP**

SHOCKING BLUE • MICHEL POLNAREFF  
TEE SET • GEORGE BAKER SELECTION  
GILLES MARCHAL • GERARD PALAPRAT  
ISLEY BROTHERS • MARTHA VELEZ  
MIGUEL RIOS • GIORGIO  
SAINT PREUX

**BAM**

Distributed Exclusively by DISCODIS 32 rue Francois 1<sup>er</sup>, Paris 8<sup>e</sup>

éditions musicales  
fantasia

a YOUNG publishing company  
first hits in 1970

by: **SHOCKING BLUE**  
**DALIDA**  
**REGINE**  
**FRANCOISE HARDY**  
**CLAUDE FRANCOIS**  
**AIMABLE**  
**ANDRE VERCHUREN**  
**MARIE LAFORET**  
**NEW INSPIRATION**  
and  
**SAINT PREUX**

and now

éditions musicales  
fantasia

moves into production with

# CONCERTO FOR ONE VOICE

BY SAINT PREUX

world wide chart rider

\*

WHY DON'T YOU CONTACT US

RIGHT NOW?

éditions musicales

FANTASIA

3, rue de Gramont, Paris, 2<sup>e</sup>

## FRANCE'S RECORD MANUFACTURERS

### ADES

(Ades, Le Petit Menetral, Disneyland, L'Anthologie  
Sonore, Florilege, les Enfants Sages, Vista)  
141, rue La Fayette, Paris 10e  
878. 05-31  
878. 72-92

### ARION

Productions Ariane Segal  
12, rue de Faraday, Paris 17e  
227. 78-91

### AKUE

(International — Disques Akue)  
64, rue de Richelieu, Paris 2e  
742. 32-84  
742. 03-62

### BYG RECORDS

29, avenue de Friedland, Paris 8e  
359. 66-03

### GROUPE BARCLAY

Compagnie phonographique française, compagnie  
européenne du disque, Riviera  
143, avenue de Neuilly, Neuilly-sur-Seine  
722. 60-30

### COMPAGNIE PHONOGRAPHIQUE FRANCAISE

143, avenue de Neuilly, Neuilly-sur-Seine  
722. 60-30

### COMPAGNIE EUROPEENNE DU DISQUE

17-19, rue Soyier, Neuilly-sur-Seine  
637. 25-80  
(Erato, Vanguard, Amadeo, Chess, Checker, Atco, Volt,  
Jag, Stax, GRT, Douglas, Cadet, Riviera, Disques Ca-  
netti, Belier)

### RIVIERA PRODUCTION

20, rue d'Armenonville, Neuilly-sur-Seine  
722. 19-50

### C.B.S.

3, rue Freycinet, Paris 16e  
PAS. 26-45  
POI. 38-05  
(CBS, Epic, Temporel, Maxi, Vee Jay, Supraphon,  
Wergo, Arion, Le Verger, C.G.O.)

### DISQUES JACQUES CANETTI

252, Faubourg Saint-Honore, Paris 8e  
227. 60-24  
(Jacques Canetti, Belier, MN, Libellule)

### LE CHANT DU MONDE

32, rue Beaujon, Paris 8e  
WAG. 67-73  
(Melodia, Folkways, Barenreiter, Cantate, Valois)

### CONSUL

6, rue de la Mare, Paris 20e

### DECCA SOCIETE FRANCAISE DU SON

30, rue Beaujon, Paris 8e  
924. 33-60  
(Decca, Deram, London, Vega, Janeret, Argo, Cycnus)

### DISCAZ

32, rue Francois-1er, Paris 8e  
359. 38-29

### PRODUCTIONS DECIBEL

95, rue La Boetie, Paris 8e  
824. 45-54

### ERATO (FIORI MUSICALI — Editions Costallat S.A.)

60, rue de la Chaussee-d'Antin, Paris  
TRI. 78-71

### FESTIVAL

3, rue de Grammont, Paris 2e  
RIC. 96-10

### FLECHE

122, boulevard Exelmans, Paris 16e  
628. 30-49

### DISQUES GERMINAL

4, rue Claude-Tillier, Paris 12e  
628. 30-49

### HOMERE

3, cite Magenta, Paris 10e  
208. 93-80

### IRAMAC FRANCE

17 bis, rue des Tilleuls, Boulogne-sur-Seine  
603. 59-62  
(Iramac, Dover, Pelca, Saba-MPS, Europa, Somerset,  
Turnabout, Candide, Muza, Auditorium)

### DISQUES JOC

29, avenue de Friedland, Paris 8e  
359. 66-03

### LES EPIS, LA VOIX DES NOTRES

14, bd. des Filles-du-Calvaire, Paris 11e  
ROQ. 36-58

### DISQUES KATEMA

68, rue Boursault, Paris 17e  
622. 60-43

### LIBERTY-UA

48 Avenue Victor Hugo  
PAS 89-19

### L'ENCYCLOPEDIE SONORE — Librairie Hachette

116 bis, Champs-Elysees, Paris  
ELY. 33-46

### DISQUES MEYS

10, rue Saint-Florentin, Paris 1er  
073. 85-05

### MISTRAL (SAM)

26, rue du Chateau-d'Eau, Paris 10e  
BOT. 28-85

### MUSIDISC-EUROPE

7, rue Traversiere, Courbevoie 92  
333. 59-49  
(Musidisc, Visadisc, Bel Air, Vox, Cetran, Savoy, Turn-  
about, Score America)

### MONDE MELODY

6, rue Vivienne, Paris 2e  
236. 71-75

### OCG: UNIDISC-PASTORALE ET MUSIQUE

31, rue de Fleurus, Paris 16e  
548. 41-61  
548. 49-95

### PATHE MARCONI — Les industries musicales et elec-

triques  
19, rue Lord-Byron, Paris 8e  
225. 53-00

(La voix de son maitre, Columbia, Pathe, Capitol,  
Odeon, Thomson-Ducretet, Les discophiles français,  
ABC, Command, Liberty, United-Artists, Dot, Durium  
Impulse, Stateside, Blue Note, Paramount, Good  
Time Jazz, Contemporary, Tamla Motown, Telefun-  
ken, Immediate, Bell, Apple, Harvest, Regal, Trianon,  
Cairophon, Baidaphon, Voix de l'Orient, Voix de  
l'Islam, Voix du Liban, Soutelphan)

### PHILIPS

53, avenue Franklin Roosevelt, Paris 8e  
225. 70-40

(Fontana, Mercury, Pergola, Disques Carrere, Oiseau  
Lyre, Ember-Stable, Beacon, Island, Disques Fleche)

### PRESIDENT

21, rue Pierre Semard, Paris 9e  
TRU 02-28 (service commercial)

30, rue Pierre Semard, Paris 9e  
LAM. 49-20 (service artistique)

### POLYDOR

2, rue de Cavallotti, Paris 18e  
522. 05-39

(Polydor, Deutsche Grammophon, Archiv Produktion,  
A&M, Abnak, Ades, International Polydor, Kama  
Sutra, King, Marmalade, M.G.M., Riverside, R.S.O.,  
Stigwood, Storyville, Tetragrammaton, Triumph,  
Verve, Verve Forecast, V.S.P., Avant-Garde, Ricordi)

### R.C.A.

52, avenue Hoche, Paris 8e  
622. 37-57

227. 19-92

227. 16-34

### S.M. — MONASTERES — CATHEDRALES — REFLETS

— LUMEN  
54, rue Michel-Ange, Paris 16e  
224. 50-60

### DISQUES VOGUE

82, rue Maurice-Grandcoing, Villetaneuse  
752. 73-00

20 bis, rue Louis-Philippe, Neuilly-sur-Seine  
722. 05-30

### RSOF

The Robert Stigwood Organisation France  
17, rue Monsigny, Paris 2e

742. 05-23

### TYPIC — EDITIONS J. GARZON

13, rue de l'Echiquier, Paris 10e  
PRO. 39-15

### WELP DISQUES

18, rue Pigalle, Paris 9e  
874. 24-41

### YOUNG INTERNATIONAL

29, avenue de Friedland, Paris 8e  
359. 66-03

FRANCE: The Past 12 Mos.

(Cont'd from Preceding Page)

Please" by Sheila and "Azuro" by Regine . . . Serge Gainsbourg causing a lot of noise with his erotic record: "Je T'Aime Moi Non Plus" banned in many countries and yet selling like hot cakes Philips who had the original recording of the song dropped it and now Gainsbourg's hit is on Disc'Az . . . Musidisc buying le Club Francais du Disque with a catalogue of over 400 different LP's . . . Official: Pathe Marconi now releasing in France the United Artists and Liberty labels directed by Eddie Admis. Eddie Admis can now concentrate his work on one outlet instead of two since until now Philips was releasing the United Artists label . . . Records enjoying very important sales for the first six months, of the year: "Que Je T'Aime" by Johnny Hallyday and "Alors Je Chante" by Rika Zarai topping the summer sales . . .

OCTOBER: CBS reports a raise in sales of 76% from May 1968 to April

1969 . . . Jack Robinson securing the Creedence Clearwater Revival catalogue for France under his publishing company: Criterion . . . Gerard Meys has signed Isabelle Aubret to his record label . . . Philippe Thomas (Musidisc) strongly takes position against the hit parade compiled by the CIDD . . . LP's are definitely selling more and more, following thus a worldwide trend . . . Following the devaluation of the Franc, exports seem to be more important these last few weeks. Pathe for instance registered a 20% rise in export sales. Polydor puzzled about the path to follow regarding its very important import from Germany. Records cost more and more and yet the French Government strictly forbids any raise in the prices . . .

NOVEMBER: Jean-Jacques Tilche now head of Edition Tutti. Pierrard left Tutti with Max Amphoux to start their own Allo Music . . . "Adieu Jolie Candy" by J. F. Michael the surprise hit of the year. A real sleeper. It start-

(Con't. on Page 82)

**Thank You**  
**B.M.I.**  
**For The Award**  
**for**  
**“MY WAY”**

**Original Words and Music by**  
**Gilles Thibault · Jacques Revaux · C. Francois**

**and**

**Thanks To All Those**  
**Who Made**  
**The Song A Hit**

**NOUVELLES EDITIONS BARCLAY**

# FRANCE'S MUSIC PUBLISHERS

**AGEL L**  
94, rue Rene Boulanger, Paris 10e  
COM. 59-86  
BOT. 17-17

**ALLELUIA**  
10, rue St-Florentin, Paris 1er  
073.85-05

**ALLO MUSIC**  
5 rue Clement Marot, Paris 8  
ELY.37.09

**ALPHA**  
54, rue d'Hauteville, Paris  
TAI. 93-82

**AMOUR**  
24, rue P. Semard, Paris 9e  
TRU. 56-39

**ANDORRA**  
52, fg St-Martin, Paris  
NOR. 45-91

**APRIL MUSIC**  
3, rue Freycinet, Paris 16e  
704. 65-76

**ARC DE TRIOMPHE**  
2 bis, rue Sainte-Genevieve, Courbevoie  
DEF. 54-54

**ARLEQUIN**  
12, bd Poissonniere, Paris 9e  
PRO. 86-03

**ARMAGNAC**  
idem.

**ARPEGE**  
25, bd Beaumarchais, Paris 6e  
TUR. 09-03

**ASSOCIES (les editions)**  
48 Avenue Victor Hugo  
PAS. 89-19

**AZNAVOUR**  
124, rue La Boetie, Paris 8e  
BAL. 80-30

**BABOD**  
20 Bis rue Louis-Philippe, Neuilly  
722.05-30

**BAETZ PH et Cie**  
52, rue du fg St-Martin, Paris 10e  
NOR. 45-91

**BAGATELLE**  
10, rue Washington, Paris 8e  
ALM. 17-99

**BALS DE FRANCE**  
94, rue du General de Gaulle, Rosny-sous-Bois

**BARCLAY (les nouvelles editions Eddie)**  
44, rue de Mirosmesnil, Paris 8e  
ANJ. 87-80

**BAUDOIN**  
91, rue de Rome, Paris 8e  
EUR. 20-95

**BAXTER Francis**  
6, avenue Parmentier, Sevran  
AVR. 51-02

**BELIER S.A.**  
252, fg St-Honore, Paris 8e  
227. 60-24

**BESSEL W et Cie**  
78, rue de Monceau, Paris 8e  
LAB. 02-13

**BEUSCHER**  
25, bd Beaumarchais, Paris 4e  
TUR. 09-03

**BILLAUDOT**  
14, rue de l'Echiquier, Paris 10e  
PRO. 13-77

**BOOSEY AND HAWKES**  
4, rue Drouot, Paris 9e  
PRO. 73-44

**BORNEMANN et editions P. DECOURCELLE**  
15, rue de Tournon, Paris 6e  
DAN. 05-88

**BOURCIER**  
12, bd Poissonniere, Paris 9e  
PRO. 86-03

**BOUSQUET**  
61, fg St-Denis, Paris 10e  
PRO. 15-35

**BRETAGNE**  
43, rue Fessart, Boulogne-Billancourt  
605. 02-06

**BRETON**  
3, rue Rossini, Paris 9e  
824. 86-19  
824. 53-64

**BYG MUSIC**  
29, avenue de Friedland, Paris 8e  
359. 66-03

**CALVI Gerard**  
54, rue d'Hauteville, Paris 10e  
TAI. 93-82

**CALIFORNIA**  
2, avenue de Messine, Paris 8e  
LAB. 06-03

**CAMIA (France Continentale)**  
80, rue Rene Boulanger, Paris 10e  
NOR. 06-54

**CARRARA**  
86, rue du fg St-Martin, Paris 10e  
206. 43-37

**CARROUSEL**  
20 bis, rue Louis-Philippe, Neuilly  
722. 05-30

**CAYLA**  
33, fg St-Martin, Paris 10e  
BOT. 91-66

**CHAILLLOT LA MOISSON**  
37, rue de Chaillot, Paris 16e  
704. 62-49

**CHAMPS-ELYSEES**  
5, av. de l'Opera, Paris 1er  
073. 37-37

**CHANTALINE**  
187, av. Paul Doumer, Triel (S.O.)

**CHANT DU MONDE (le)**  
32, rue Beaugon, Paris 8e  
WAG. 67-73

**CHAPPELL**  
4, rue d'Argenson, Paris 8e  
ANJ. 56-05

**CHOUDENS**  
38, rue Jean Mermoz, Paris 8e  
BAL. 17-21

**CLAUDE PASCAL**  
14 Rue Lincoln  
BAL. 92-14

**COLBY**  
87-89, rue La Boetie, Paris 8e  
ELY. 76-54

**COLIBRI**  
19 A, rue Caumartin, Paris 8e  
OPE. 54-48

**COMTESSE**  
44, rue de Mirosmesnil, Paris 8e  
ANJ. 87-80

**COMUFRA (M. Legrand)**  
252, fg St-Honore, Paris  
Mac. 50-16  
MAC. 55-69

**CONTINENTALES**  
15, rue Saussier-Leroy, Paris 17e  
924.83-89

**COSTALLAT**  
60, Chaussee d'Antin, Paris 9e  
TRI. 78-71

**CONSUL**  
6, rue de la Mare, Paris 20e  
636. 81-46

**CONTEMPORAINES**  
99, av. Simon Bolivar, Paris 19e  
BOL. 68-19

**COURCELLES**  
49, avenue Montaigne, Paris 8e  
ALM. 10-98

**D'ANELLA**  
7, rue St-Lazare, Paris 9e  
TRU. 76-96

**DANY MUSIC**  
134, boulevard Haussmann, Paris 8e  
227. 64-53

**DE CLERCQ (France Vedettes)**  
44, rue du Colisee, Paris 8e  
BAL. 69-83

**DECRUCK Maurice**  
61, av. Raymond Poincare, Paris 16e  
PAS. 69-69

**DERBY**  
95, bd Beaumarchais, Paris 3e  
272. 37-98

**DICADO**  
1, square de la Mayenne, Paris 17e  
380. 68-25

**DIGOUE DIODET**  
39, fg St-Martin, Paris 10e  
BOT. 28-61

**DISCOTHEQUE DE PARIS**  
55 bis, rue de Ponthieu, Paris 8e  
225. 61-73

**D.M.F.**  
14, avenue Hoche, Paris 8e  
WAG. 81-93

**DO RE MI.**  
5, rue Lincoln, Paris 8e  
ELY. 50-90

**DORSAY**  
69, fg St-Martin, Paris 10e  
NOR. 61-50

**DREJAC**  
60, rue Francois 1er, Paris 8e  
ELY. 62-36

**DURAND et Cie**  
4, pl. De la Madeleine, Paris 8e  
OPE. 45-74

**ECO MUSIC**  
19, rue Lord Byron, Paris 8e  
BAL. 53-00

**EDITIONS MUSICALES LMB**  
13, rue Washington, Paris 9e  
225. 43-03

**EMILHENCO**  
88, rue du fg St-Martin, Paris 10e  
206. 71-54

**ENOCH**  
27, bd des Italiens, Paris 2e  
RIC. 69-95

**E.P.M. Sagittaire**  
7 bis, rue Paul-Valery, Paris 16e  
727. 08-10

**E.P.O.C.**  
71, rue de Provence, Paris 9e  
874. 15-68

**ESCHIG (Max)**  
48, rue de Rome, Paris 8e  
LAB. 66-64

**ESSEX**  
34 Champs-Elysees, Paris 8e  
225. 69-60

**EUROFRANCE**  
67, rue de Provence, Paris 9e  
874. 19-41

**EUROPA**  
27, rue de l'Echiquier, Paris  
PRO. 19-45

**FANTASIA**  
3, rue de Gramont, Paris 2e  
RIC. 61-23  
RIC. 96-10

**FELDMAN**  
5, av. de l'Opera, Paris 1er  
OPE. 37-37

**FESTIVAL**  
3, rue de Gramont, Paris 2e  
RIC. 61-23  
RIC. 96-10

**FIESTA**  
87-89 rue La Boetie, Paris 8e  
ELY. 67-54

**FORTIN**  
4, cite Chaptal, Paris 9e  
TRI. 58-34

**FRANCE MELODIE**  
5, av. de l'Opera, Paris 1er  
OPE. 33-11  
OPE. 37-37

**FRANCIS DAY**  
5, av. de l'Opera, Paris 1er  
OPE. 33-11  
OPE. 37-37

**FRANCE RECORD**  
33, rue Marc Seguin, Paris 18e  
206. 71-08

**FRENCH MUSIC**  
124, rue La Boetie, Paris 8e  
BAL. 80-30

**FRIZZA**  
56, rue de Paradis, Paris 10e  
PRO. 19-64

**GARZON J.**  
13, rue de l'Echiquier, Paris  
PRO. 39-15

**GASTE L.**  
5, rue du Bois de Boulogne, Paris 16e  
POL. 53-53

**GOLF**  
8, bd. Julien-Potin, Neuilly

**GRANDE AVENUE**  
49, av. Hoche, Paris 8e  
227. 16-34

**GRECH Francois**  
242, rue de Charenton, Paris 12e

**HAMELLE et Cie**  
24, bd. Malesherbes, Paris 8e  
ANJ. 36-39

**HARMONIA**  
35, boulevard Malesherbes, Paris 8e  
ANJ. 08-93

**HELIAN**  
252, fg St-Honore, Paris 8e  
MAC. 50-16

**HEUGEL**  
2 bis, rue Vivienne, Paris 2e  
GUT. 43-53

**HOHNER**  
19, rue Van Loo, Paris 16e  
BAG. 63-50

**HOMERE**  
3, Cite Magenta, Paris 10e  
208. 93-80

**HORTENSIA**  
46, rue de Douai, Paris 9e  
TRI. 52-64

**IGLOO**  
3, rue de Gramont, Paris 1er  
742. 96-10

**IMPERIA**  
8, rue St-Marc, Paris 1er  
236. 69-18

**ISABELLE MUSIQUE**  
95, rue La Boetie, Paris 8e.  
824. 45-54

**JOUBERT**  
25, rue d'Hauteville, Paris 10e  
PRO. 15-73

**JEUNE MUSIQUE**  
122, bd Exelmans, Paris 16e.

**JOBERT**  
44, rue du Colisee, Paris 8e  
ELY. 26-82

**KATEMA**  
68, rue Boursault, Paris 17e  
622. 60-43

**LABRADOR (editions)**  
29, Cite d'Antin, Paris 9e  
225. 77-32

**LA COMPAGNIE**  
11, rue Magdebourg, Paris 16e  
553. 53-13

**LASRY A.**  
62, bd de Clichy, Paris 18e  
MON. 53-00

**LEDUC A.**  
175, rue St-Honore, Paris 1er  
OPE. 12-80

**LEMOINE et Cie**  
17, rue Pigalle, Paris 9e  
TRI. 09-25

**LES TROIS MOUSQUETAIRES**  
20, rue Lauriston, Paris 16e  
704. 98-40

**LOUISE**  
45, rue Fessart. 92 Boulogne  
Billancourt  
605. 02-06

**MAJESTIC S.A.**  
252, fbg St-Honore, Paris 8e  
227. 60-24

**MALESHERBES**  
11, bd Malesherbes, Paris 8e  
ANJ. 77-33

**MANDY MUSIC**  
95, rue Championnet, Paris 18e  
225. 49-95

**MANEGES**  
95, rue de la Boetie, Paris 8e  
824. 45-54

**MARINE**  
44, rue de Mirosmesnil, Paris 8e  
265. 87-80

**MASSPACHER**  
39, passage du Grand Cerf, Paris 2e  
GUT. 02-02

**MAX ESCHIG**  
48, rue de Rome, Paris 8e  
LAB. 66-64

**MERIDIAN**  
5, rue Lincoln, Paris 8e  
359. 06-22

**METROPOLITAINES**  
3, rue Rossini, Paris 9e  
TAI. 83-94  
PRO. 21-78

**MEYER William**  
9, place Malesherbes, Paris 17e  
622. 13-29

**MEYS (Gerard)**  
10, rue Saint-Florentin, Paris 1er  
742. 44-34

**MICRO**  
14, rue Washington, Paris 8e  
BAL. 43-03

**MONDE MELODIE**  
6, rue Vivienne, Paris 2e  
236. 71-75

**MONDIA**  
46, rue Laffitte, Paris 9e  
TRU. 07-75

**MONTE BELO**  
33, rue Le Peletier, Paris 9e  
PRO. 08-53

**MOULIN (Productions musicales du)**  
18, av. La Bourdonnais, Paris 7e  
468. 88-81

**MUSIC 18**  
10, rue Washington, Paris 8e  
256. 17-99

**O. EDITIONS O.**  
11, rue Lepic, Paris 18e  
606. 94-30

**OUVRIERES**  
12, av. Soeur Rosalie, Paris 13e  
GOB. 29-07

**PARES PH.**  
46, rue Laffitte, Paris 9e  
526. 40-42  
878. 07-79

**PARIS ETOILE**  
17, rue Montigny, Paris 2e  
742. 05-23

**PARIS MELODIE**  
76 Champs-Elysees, Paris 8e  
BAL. 49-80

**PASCAL Claude**  
14, rue Lincoln, Paris 8e  
225. 92-14

**PATHE MARCONI**  
19, rue Lord Byron, Paris 8e  
225. 53-00

**PATRICIA**  
5, rue Lincoln, Paris 8e  
ELY. 06-22

**PEPE LUIZ (editions musicales)**  
14, rue Chaptal, Paris 9e  
744. 24-03

**PHILIPPO**  
24, bd. Poissonniere, Paris 9e  
TAI. 89-24

**PLANTE**  
35, bd. Malesherbes, Paris 8e  
ANJ. 08-93

**PLEINS FEUX**  
12, bd. Poissonniere, Paris 9e  
PRO. 25-02  
PRO. 86-04

**PRESENCE**  
33, fg Saint-Martin, Paris 10e  
NOR. 89-05

**PRISMA MUSIC**  
40, fg Poissonniere, Paris 10e  
PRO. 53-01

**PROCURE GENERALE des paroisses  
des communistes et du clerge**  
76, bis, rue des Saints-Peres, Paris 4e  
LIT. 70-50

**PROSADIS**  
14, av. Hoche, Paris 8e  
622. 45-00

**PUBLICATIONS MUSICALES INTERNATIONALES**  
5, rue Drouot, Paris 9e.  
824. 63-63

**RAILLET**  
12, passage de l'Industrie, Paris 10e  
TAI. 44-55

**REVEL**  
71, rue de Provence, Paris 9e  
TRI. 90-76

**RHODANIA**  
4, rue Juste Metivier, Paris 18e  
ORN. 84-30

**RICORDI**  
3, rue Roquepine, Paris 8e  
ANJ. 94-15  
ANJ. 51-47

**LE RIDEAU ROUGE**  
24, rue de Longchamp, Paris 16e  
704. 52-37

**ROYALTY**  
25, rue d'Hauteville, Paris 10e  
PRO. 67-26

**SACHA**  
11 av. Delcasse, Paris 8e  
BAL. 91-51

**SALABERT**  
22, rue Chausat, Paris 9e  
TAI. 56-60

**SALVADOR**  
6, place Vendome, Paris 1er  
OPE. 87-05

**SALVET-ASSOCIEES**  
89, rue La Boetie, Paris 8e  
ELY. 76-54

**SARAVAH**  
29, avenue Friedland, Paris  
359. 66-03

**SCHOLA CANTORUM**  
269, rue Saint-Jacques, Paris 5e  
033. 56-74

**SEMI (Societes d'editions  
musicales internationales)**  
5, rue Lincoln, Paris 8e  
359. 06-22

**SFORZAADO**  
12, rue Lermecier, Paris 17e  
387. 88-86

**SONOPRESSE**  
9, rue Stanislas, Paris 6e  
222. 86-20

**SUGAR MUSIC**  
90, av. Champs-Elysees, Paris 8e  
256. 35-49  
236. 35-59

**SUNNY MUSIC**  
7 bis, rue Paul-Valery, Paris 16e  
704. 50-95

**SYNCHRO-FOX MUSIC LIBRARY**  
(voir editions Labrador)

**TELE CINE DISQUES**  
22, rue Charcot, Paris 13e  
587. 33-33

**TOP 2000**  
1, rue Magellan, Paris 8e  
225. 42-01

**TOUNESOL**  
68, rue Lhomond, Paris 5e  
707. 25-81

**TROPICALES**  
28, bd Poissonniere, Paris 9e  
PRO. 25-28

**TUTTI**  
15, rue Saussier-Leroy, Paris 17e  
924. 83-89

**UNIVERSELLES**  
52, fg. Saint-Martin, Paris 10e  
NOR. 45-91

**VENDOME**  
5, rue Lincoln, Paris 8e  
ELY. 10-81

**WALT DISNEY**  
3, rue Freycinet, Paris 8e  
704. 65-76

**WELP**  
18, rue Pigalle, Paris 9e  
874. 24-41

**ZURFLUH A.**  
73, bd Raspail, Paris 6e  
BAB. 29-26  
LIT. 68-60



**Un Peu . . .**

**Beaucoup . . .**

**A La Folie**

**We Love Music !**

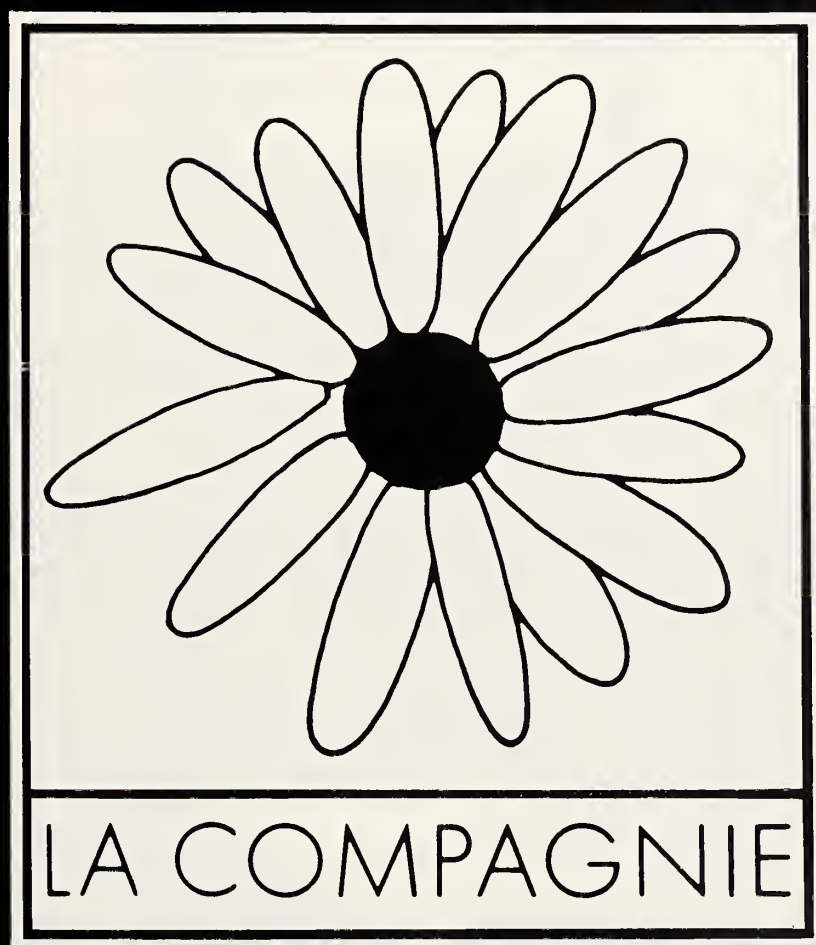

LA COMPAGNIE Record and Publishing Co.  
Espiegle Publishing  
La Boetie Music

Distributor in France for  
MCA Records  
CARNABY Records  
CREWE Records

# HOLLAND: The Past 12 Months

## JUNE

This month **Shocking Blue's** 'Venus' was released by Dureco; it became a worldwide hit in 1970. Negram launched 'Ma Belle Amie' by Dutch top-formation **Tee Set**. Dutch rock-group **The Motions** were one of the first acts from Holland to perform in the US; Mercury released their "Electric Baby" album. Dutch pirate radiostation **Radio Veronica** had world premiere of new **Rolling Stones** record 'Honky Tonk Women'. **Beach Boys** - **Paul Revere** and the **Raiders** concert in Amsterdam and **Les Compagnons de la Chanson** concert in Emmeloord. Thirty-five thousand people were visiting the first Amsterdam open air stadium concert with top of the bill Dutch singing couple **Gert & Hermien**. During this unique happening they received their twelfth gold disc for 50,000 'Gert en Hermien Show' LP's. **The Edwin Hawkins Singers** caused a stir with their Buddah-bomber 'Oh Happy Day', within 3 weeks time no. 1 in Holland. Polydor started the re-release of the Verve-Jazz-catalogue. **Richie Havens** in Holland. Release on the Track label of the complete popopera 'Tommy' of the **Who**. Messrs. **Oeges** and **Knipschild** with Polydor. Although the international attractions (**Gilbert Becaud**, **Dusty Springfield**, **Melanie**, **Sandie Shaw**, etc.) were great, Hollands first International Song Contest 'Singing Europe' flopped completely; fifteen countries participated. Barclay clarinetist **Jean Christian Michel** and his 'Musique Sacree' quartet did a very successful tv.

## JULY

Bovema acquired the Tamla Motown label and did a special promotion campaign for **Franck Pourcel**. The music of the original Dutch stage-version of the musical 'Sweet Charity' was released on the Philips-label by Phonogram. Dutch group **The Cats** performed in the U.S. Special **Billy Vaughn** month of Negram. N.V. Phonogram rush-released an album called 'Man

On The Moon' only a few days after the actual landing. The record featured all original sounds from the Apollo 11 flight. Sales were impressive. **Sylvie Vartan** visited Holland on the occasion of a special French week in Emmeloord, as well as **Dalida**. The **Ohio Express** visited Holland as one of the countries of their European tour. TV-performance of Montana artist **Alexandra**, who died a few weeks after. Basart Records International got the exclusive representation of the Studio-33 label. 'Big Bamboo' big summerhit. **Robin Gibb** in Holland. Polydor acquired the 'Chess' label for Holland; first single 'Love Is Blue' by **Dells** became a Top 20 record. **Peter Nero** did a concert and two TV-programs. The complete British cast of 'Hair' came to Holland for one single performance.

## AUGUST

**Robert Stolz** toured Holland and he was presented with a Golden Record. Bovema launched its Fall-Campaign with 250 records originating from all labels and local recordings, a.o. the best selling series: 'The Best Of . . .'. Dutch bluesgroup **Cuby & The Blizzards** did a tour of England and was a smash at the Plumpton Festival. **Melanie** in Holland to promote her album 'Back In Town'. Another big star visiting sunny Holland was **Mireille Mathieu**. Barclay's number one singer. **Jan van Schalkwijk** attended the Split Songfestival in Yugoslavia and bought a.o. the winning song for Germany, Switzerland and Austria. A first album by the known Dutch opera-singer **Christina Deutekom** was released by Phonogram (Philips). DGG-label started the 'Beethoven Year' with the release of the complete works by Beethoven. Bovema did a heavy campaign for the **Walt Disney** catalogue. Barclay Holland acquired the representation of the fast growing German MPS label.

## SEPTEMBER

Winners of the Edison-award (popular category), period 1st September 1968-31st August 1969, were announced: **Nana Mouskouri**, **Andy Williams**, **Anita Kerr Singers**, **Sergio Mendes & Brasil 66**, **Jose Feliciano**, **Liesbeth List**, **Rita Reys**, **Herb Alpert & The Tijuana Brass**, **Harry Mooten**, **Bill Evans**, **Adele Bloemendaal**, **Fons Jansen**, **Barbara**, Broadway cast of 'Hair', **Johnny Cash**, **Blood, Sweat & Tears**, **The Who**, **Fifth Dimension**, **Melanie**, **Leonard Cohen**, **The Cats**, the productions of 'Oebele', the Jazz Vintage Series and

**Heintje**. Dutch popgroup **Sandy Coast** signed a worldwide contract with **Page One Records**. Phonogram's well known promo-team started a campaign for the Island label, combined with a release of seven new Island albums and a tremendous **Jethro Tull** performance in Amsterdam. 'Je T'Aime . . . Moi Non Plus' of **Jane Birkin** and **Serge Gainsbourg** very big hit. First LP of **Shocking Blue**, 'At Home', was released by Dureco. Inelco started the stereo 8 and musicassettes publicity

(Con't. on Page 80)

## HOLLAND'S GOLD SINGLES — 1969/70

Bloody Mary	Tom & Dick	Philips
Dear Ann	George Baker Selection	Negram
De Laatste Dans	Anja	11 Provinciën
Gina Lollobrigida	Tony Bass	Delta
Jerushala'um	Rika Zarai	Philips
Hair	Zen	Philips
Het Spel Kaarten	Cowboy Gerard	Delta
Lea	The Cats	Imperial
Ma Belle Amie	Tee Set	TSR
Mijn Gebed	D.C. Lewis	Philips
My Special Prayer	Percy Sledge	Atlantic
Sha La La I Need You	Shuffles	CBS
Venus	Shocking Blue	Pink Elephant
Why	The Cats	Imperial

## HOLLAND'S GOLD ALBUMS — 1969/70

Back In Town	Melanie	Buddah
Born To Be	Melanie	Buddah
Cats	The Cats	Imperial
Ekseption	Ekseption	Philips
Fantastic Feliciano	Jose Feliciano	RCA Victor
Gert en Hermien Show no. 3	Gert en Hermien	CNR
Hair	Broadway Cast	RCA Camden
James Last Op Klompen	James Last	Polydor
James Last In Concert	James Last	Polydor
Onder Moeders Paraplu	James Last	Polydor
Liesbeth List sings Theodorakis	Liesbeth List	Philips
Pastorale	Liesbeth List	Philips
The Best Of Mantovani	Mantovani	Decca
Woodhouse In Wein	John Woodhouse	Philips

# A GREAT MANY RECORD COMPANIES WERE AHEAD OF YOU:

ARIOLA -  
BARCLAY - BUDDAH - MELODIA -  
HED ARZI - SPARK -  
TELEFUNKEN have entrusted  
their interest to the fastest  
growing record company in  
the netherlands

Why did they  
do this? Simply  
because  
CNR fights for its labels



CNR RECORD COMPANY POSTBOX 420 LEYDEN HOLLAND

# How to send a label all over the world (and have it marketed in 130 countries)

## put it in the philips bag



in Holland....

# NEGRAM KNOWS,

# WHICH WAY THE WIND BLOWS



We use our knowledge. In fact we use everything to stir up sales-storms. That's why we've got so many hits these days. That's why our hits sell in bigger quantities. If you want to get more profit from your hits, there's only one thing to do. Get in touch with managing director Hans I. Kellerman of this swinging, dynamic record company called NEGRAM! He will tell you all about it. Write us at P.O. Box 345, Haarlem, Holland. It's even better to phone us at 023-319247. And when you're touring the continent, don't hesitate to visit our cosy office at Zijlweg 154, Haarlem. Then you're sure to score (more) hits in Holland.

## HOLLAND'S RECORD MANUFACTURERS

### ARIOLA-EURODISC BENELUX N.V.

Baan 15  
Haarlem  
Tel.: 322640  
Telex: 41385  
Director: Jan van Schalkwijk  
Labels: Ariola, Ariola-Athena, Ariston Records, Athena, Avco Embassy, Baccarola, Cetra (Holland only), Eurodisc, Gemini Records, Maritim, Request (Holland only), T.W.R.

### BASART RECORDS INTERNATIONAL

Houtmankade 20  
Amsterdam  
Tel.: 222 192-63209-241260  
Director: F. Basart  
Labels: Apollo, Asch Records, Broadside Records, Camera, Candide (Vox), Cantate, Christophorus, Da Camera, Donald Duck, Durium, Europhon, Folkways, Hosanna, I.D.R., Main Records, Mandolino, Musiphon, Park, Rim, Sastruphon, Sibbe, Studio 33, Super Majestic, Trianon, Turnabout (Vox), Turnette, Varagram, Vox.

### N.V. VERKOOPMAATSCHAPPIJ BOVEMA

Bronsteeweg 49  
Heemstede  
Tel.: 280750  
Telex: 41257  
Director: Mr. Gerry Oord  
Labels: Columbia, Parlophone, H.M.V., Odeon, Regal Zonophone, Harvest, Pathe, Duc. Thompson. State-side, Capitci, Liberty/UA group of labels, ABC Paramount group of labels, Dunhill, Monument, Immediate, Tamla Motown, Invictus, Amaret, Bell, Transatlantic, Apple, Catfish, E.G. Records, Byg, Blue Thumb, Crewe Records, Angel, Fastback, Walt Disney, Pikwick, Fantasy, Ember, Contemporary, Credo, Carnaby, Studio Two, Imperial

### CBS-ARTONE N.V.

Kruisstraat 8-10  
Haarlem  
Tel.: 319250  
Telex: 41051  
Director: Bill C. Slinger  
Labels: Arion, Artone, Ascot, Barennaier, Barnaby, Blue Horizon, CBS, Dandelion, Disques Mouloudji, Disques Temporel, Epic, Festival, Hickory, Milestone, Okeh, Palette, Scout, Specialty

### N.V. GRAMMOFOONPLATENMAATSCHAPPIJ CNR

Postbus 420  
Leiden  
Tel.: 44244  
Telex: 32686  
Director: Hans van Zeeland  
Labels: CNR, Lowland, Ariola-Eurodisc, Armada, Barclay, Buddah, Erato, Hed Arzi, Melodia, MPS, Qualiton, Riviera, Spark, Telefunken, Unicorn.

### N.V. DURECO

Beursstraat 21  
Amsterdam  
Tel.: 242288  
Telex: 14409  
Director: Mr. Robert A. Aardse  
Labels: Ad Rythm, Alhambra, Audio Fidelity, Bellaphon, Capri, Carpenter, Dsic AZ, Elf Provincien, Gemeentezang Urk, Golden 12, Hebra, Historia, Jad, Luxor Populaire, Major Minor, Mata Hari, Metronome, Transport, O Lala, Omega, Perl, Standard, Starlet, Te Deum, Top Classic, Top Music, Vega, Weekend, Pink Elephant, Blue Elephant

### INELCO

A.J. Ernststraat 801  
Amsterdam-Buitenveldert  
Tel.: 421722  
Telex: 14622  
Director: Wom Brandsteder  
Labels: RCA, MCA, Vanguard, Amadeo, Elite, GWP

### NEGRAM-DELTA N.V., VERKOOPMIJ.

Zijlweg 154,  
Haarlem  
Tel.: 319247  
Director: Hans I. Kellerman  
Labels: Acta, Clave, Cornet, Delta, Design, Dot, Eagle, Elektra, Entertise, Golden Guinea, Green Light, Havoc, Hispavox, Hot Wax, Marble Arch, Marfer, Metromedia, Negrgram, Nonesuch, Paramount, Peerless, Pye, Reprise, Saga, Sanctus, Stax, Volt, Hip, Steed, Trend, TSR, Virtuoso, Warner Bros. Janus, Valiant

### N.V. PHONOGRAM

Drentestraat 11,  
Amsterdam-Buitenveldert  
Tel.: 440888  
Telex: 12038  
Directors: Mr. J. Haslinghuis/Mr. R.H. Klaassen  
Labels: Ace of clubs, Ace of hearts, Argo, B&C, Beacon (incl. Uprfront), Beltona, Caedmon, Chapter One, Decca, Deram, D.J.M., Eclipse, Flying Dutchman (incl. Amsterdam, Blues Time), Fontana, Harmonia Mundi, Island (incl. Island-Sue, Jump Up, Trojan, Action, Amalgamated, Stable, Attack, Clandisc, Harry J., Blue Cat, Down Town, High Note, Sudio 1, Big Shot, Coxson, Duke, Upsetter, Jackpot, J-Dan, Songbird), Jayboy, London (incl. Alon, Brite Leaf, Busy-B, Challenge, Coliseum, Drew, Galaxy, Hi, Hollywood, Jamie/Gyden, Instant, Lanor, Laurie, Look, Mainstream, Marlin, M.O.C., Parrot, Phoenix, Providence, Rust, Seven B, Sire, Spectrum, Starday, Tribe, Pompeii, Time, Tune-Kel., Amos, L.H.I., Steady, Yew, Channel One, De Luxe), Mercury (incl. Intrepid, Smash, Peachtree), Oiseau-Lyre, Page One, Pama (incl. Crab, Gas, Nu-Beat, Unity), Passe-Partout, Penny Farthing, Philips, President (incl. Bronco, Excello, Falcon, Fraterniry, Jerhart, Joy, Maravilla, Mar-V-Lus, Mustang, Nashboro, One-der-ful, Presta, Seville, Sims, Stereo-Fi, Crystal, Caroussel, Tomorrow), Rex, Scepter (incl. Athena, Evolution), Threshold, Uni (incl. Revue, Shamley), Vertigo

### POLYDOR NEDERLAND N.V.

Piet Heiplein 6  
Den Haag  
Tel.: 658833  
Telex: 31481  
Directors: Mr. E.J. Garretsen/Mr. R. Oeges  
Labels: A&M, Chess, MGM, Verve, Kama Sutra, Atlantic, Atco, Vortex, Cotillion, Embryo, Track, Marmalade, Ricordi, King, Riverside, Storyville, Supraphon, Diskanto, CCA, Blossom, Action.

### N.V. TELGRAM

St. Maartenslaan 1  
Weert  
Tel.: 5539  
Telex: 51285  
President: J. Hoës

### VOGUE NEDERLAND N.V.

Spaarne 55  
Haarlem  
Tel.: 320055-320056  
Telex: 41443  
Director: Jose Leruth  
Labels: Chanson d'Orphee, Collection Sidney Bechet, Contrepoint, Deutsche Vogue, GNP Crescendo, Golden Guinea, Guardian, Joker, Jolly, Marble Arch, Mode, Orphe, Pacific, Piccadilly, Pop, Pye, Roulette, Saar, Vogue, Vibraton, Young Blood

## HOLLAND: The Past 12 Mos.

(Con't. from Page 78)

and sales. Visits of Bovema artists **Humble Pie**, **Soft Machine**. From this month on Bovema is distributor in the Netherlands of United Artists. **Wilson Pickett** did his first-ever concerts in Holland. **Percy Sledge** number one of the Dutch hitparade with 'My Special Prayer', recorded two years ago. World 'live' premiere in the Amsterdam Concertgebouw of 'Tommy' by the Who.

### OCTOBER

Entry of the **George Baker Selection** on the Dutch market (Negrgram). The group, formed 4 weeks earlier, made its debut with 'Little Green Bag', which became a big hit in the U.S. in 1970 and in other parts of the world, especially Canada, Italy and Belgium. **Buddah's Lou Christie** in Holland to promote his 'I'm Gonna Make You Mine'. **Han Dunk** of Holland Music back in the office after a stomach operation, from which he made a complete recovery. A package from Island Records did concerts in The Hague and Amsterdam. Package included **The Clouds**, **Jethro Tull**, **Free**, **Joe Cocker** and **Spooky Tooth**. Another Island group, **Fairport Convention** also made a successful appearance in Amsterdam. Three British groups, presented as the London Blues Show, did Opera House concerts in Amsterdam, Rotterdam and The Hague, with **Ten Years After** a.o. **The Rolling Stones** film 'The Stones In The Park' was shown on Dutch TV. In London, **Jose Feliciano** received the most important Dutch award, the Edison, for his LP 'Feliciano/10 to 23'. **Led Zeppelin** did three concerts in Holland. Visitors from abroad for TV-appearances: **Elaine Delmar**, and the **Peddlers**.

Roumanian pianist **Cicero** (MPS) came to Holland to do a radioshow. First release by Basart Records International of the new religious label 'Hosanna' with 4 records containing Christian Chormusic. This month equally saw the introduction of Basart's 'Record Newspaper', combining regular releases, sensational offers and miscellaneous record news.

### NOVEMBER

Negrgram scored a number one hit on the Reprise label with **Fleetwood Mac's** 'Oh Well'. Bovema acquired **Zappa's** 'Straight' label. British blues-singer **Alexis Korner** toured Holland. Visit of **Jimmy Cliff**, the long expected RCA C&W top-artists **Skeeter Davis**, **Connie Smith**, **George Hamilton IV**, **Bobby Bare** and **Nat Stuckey** 'did' Holland for promotion, as well as **Nina Simone** and **Duke Ellington**. **Herb Alpert** made a sell out concert in The Hague; it was transmitted by KRO-TV. **Louis van Dyke**, Dutch pianist well-known for his improvisation talents, produced an album with Greek actress/songstress **Dora Gianakopoulou** who lives in Holland nowadays. The new album by **Golden Earring** 'Eight Miles High' was released at the same time in Holland (Polydor) and America (Atlantic). British groups **Fat Mattress** and **The Taste** did 2 concerts and **Bill Evans** received his Edison for the Album 'Bill Evans At The Montreux Festival'. **Charles Aznavour** gave some concerts in Holland and did a tv-special. From the U.S., part of 'Up With People' arrived at Amsterdam to give a one hour show for the press and promised to come to Holland with the complete cast in June 1970. Three days jazz-festival in Rotterdam with **Duke Ellington Orchestra**, **Sarah Vaughan**,

(Con't. on Page 82)

# HOLLAND'S MUSIC PUBLISHERS

## EDITIONS ACTUEEL N.V.

(Editions Actueel N.V., Montana Benelux, Edition Caprole, Altus Music Int. c.v., Edition Wiener Boheme Benelux, Edition Literatoon, Faniare Music, S.P.V. Music)  
Zandvoortse laan 65,  
Heemstede  
Tel.: 285555  
Telex: 41385  
Director: Jan van Schalkwijk

## N.V. ALTONA

Leidsegracht 11  
Amsterdam  
Tel.: 222626  
Director: G. Jansen Jr.

## ANAGON MUSIC PUBLISHERS

(Big Sky, Dwarf, Callee, Albet, Timberhead, Penny-whistle, Milkmanchivaree Music (Benelux), Saturday, Talleyrand, Marsaint, Sanah, Stonebridge, Larry Weiss, Walt Disney, Wonderland, Gale, Walrus, M.C., Gold for Ever Music, Music de Espana (Holland) Bronsteeweg 49  
Heemstede  
Tel.: 280750  
Telex: 41257  
Director: Mr. G.M. Oord

## APRIL MUSIC HOLLAND N.V.

(Subeditions: Muziekuitgeverij J. Portengen, Jolio Music, Edition Malando, Lotus Publication)  
(April & Bleckwood (USA) + int'l affiliates, CBS, International (USA), Tree (USA), Music Rights Society (Belgium) New Music Corp. (Belgium)  
Kruisstraat 8-10  
Haarlem  
Tel.: 320525  
Telex: 41051  
Manager: Frans van Tongeren

## LES EDITIONS INTERNATIONALES BASART N.V.

Leidsegracht 11  
Amsterdam  
Tel.: 222626  
Director: Guus Jansen Jr.

## BELINDA (AMSTERDAM) N.V.

(Aberbach, Progressive, Carlin Music)  
Leidsegracht 11,  
Amsterdam  
Tel.: 222626  
Director: Guus Jansen Jr.

## BENELUX MUSIC N.V.

(Benelux Music, Tempo Music, Washington Music)  
Sint Maartenslaan 1  
Weert  
Tel.: 2620 - 5640  
Telex: 51285  
Director: J. Hoes

## BOSPEL MUSIC N.V.

(Ed. Musicales Bens (Belgium), Ed. Musicales Fonior S.A. (Belgium), Ed. Gerard Tournier (France), Grande Avenue (France), Blanche Lebeau Musicpubl. New York)  
Warmoesstraat 86  
Amsterdam  
Tel.: 226394  
Telex: 14409  
Presidents: Mrs. Janine Bosmans/ Mr. Eddy Palmans  
Managing Director: Joop Gerrits

## CHAPPELL & CO HOLLAND N.V.

Singel 170-172  
Amsterdam  
Tel.: 64790-229539  
Director: Mr. J.J. de Winter

## FRANCIS DAY MUZIEKUITGEVERS N.V.

(Francis, Day & Hunter Ltd., B. Feldman & Co., Ltd., Publications Francis-Day s.a., Editions Feldman s.a.)  
Vossiusstraat 52  
Amsterdam  
Tel.: 799973/724785  
Telex: intellect 14622  
Prof. Manager: Wim Landman

## HOLLAND MUSIC N.V.

(Peer-Southern Organization, New York, Cedarwood Pub. Co. Inc., Nashville, Tennessee, Helios, Music Group, New York, Glamorou Music Corp., New York)  
Singel 500  
Amsterdam 1  
Tel.: 231163  
Director: Han Dunk  
Gen. Manager: Elbert van Zoeren

## INTERMUSIC N.V.

(Immediate Music (Holland N.V.), R & R Music, Morgan Music Benelux, Robbyland Music)  
Herengracht 4  
Amsterdam-C  
Tel.: 231390  
Director: Cees van Zijtveld

## DAYGLOW MUSIC

De Rijklaan 1  
Hilversum  
Tel.: 16451  
Director: Willen J. van Kooten

## MELODIA MUZIEKUITGAVEN

Amstel 52  
Amsterdam-C  
Tel.: 238800  
Director: Cor Smit Jr.

## PANDA PRODUCTIONS

(I.M.C. - incl. Acuff-Rose, Charing Cross, Lowery, Screen Gems, World Music- , Jean Kluger, R.K.M., Sonet, Tree International)  
Nic. Maesstraat 41  
Amsterdam  
Tel.: 731095  
Director: Joop Portegen

## MUZIEKUITGEVERIJ TRIDENT N.V.

(Robbins Music Corp., Leo Feist Inc., Miller Music Corp., Hastings Corp.)  
Vossiusstraat 52  
Amsterdam  
Tel.: 799973/724785  
Telex: intellect 14622  
Manager: Wim Landman

## UNIVERSAL SONGS HOLLAND N.V.

(Sunbury Ltd., England, Sunbury Inc., USA, Dunbar Inc., USA, Cirrus Music, Canada, Discovery Music, Barbados, Mews Music, Engeland)  
Vossiusstraat 52  
Amsterdam  
Tel.: 799793/724785  
Telex: intellect 14622  
Manager: Wim Landman

## VERONICA MUSIC EDITIONS c.v.

Utrechtseweg 16  
P.O. Box 218  
Hilversum  
Tel.: 51045  
Telex: 16498  
Manager: Charlie Ritton



1970 —

we were founded  
we found it  
and scored a hit

**Keep on Smiling!**

James Lloyd's first

Well, here we are:

**Ariola-Eurodisc-Benelux N.V.**

a member of the Ariola-family

Haarlem/Holland — Tel. 322640 — Telex 41385

**HOLLAND**  
HAS A WAY WITH FLOWERS.....  
THEY BLOSSOM!



**GERRY OORD'S BOVEMA**  
HAS A WAY WITH RECORDS.....  
THEY SELL!

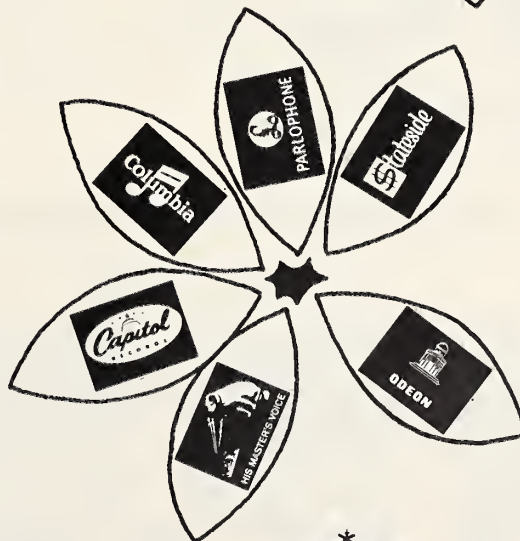
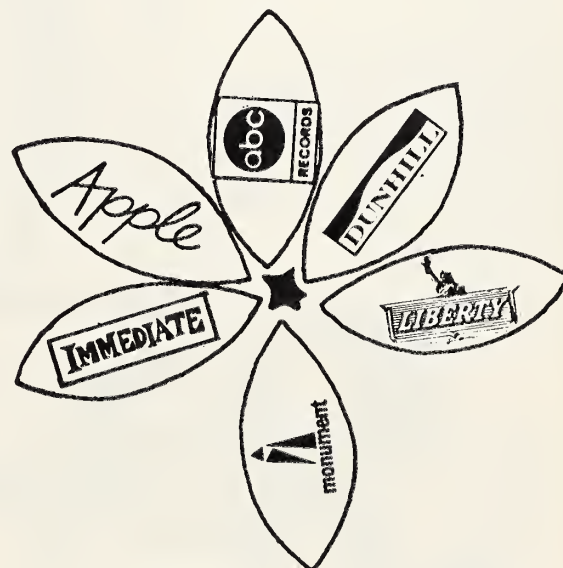

N.V. BOVEMA GRAMPHONEHOUSE HEEMSTED E HOLLAND

# BRAZIL: The Past 12 Months

## JUNE

The main event of this month has been the Latin America RCA Convention, an important reinforcer of the interchange of recordings and artists among all Latin-American countries. In this well organized gathering, some of the best recording artists from the following countries performed: Brazil, Colombia, Chile, Bolivia, Peru, Argentina, Mexico, Equador, Uruguay, El Salvador, Puerto Rico, Italy, Spain and the U.S.A. The show had its highlights in the participation of **Os Incriveis**, **Fabio** and **Antonio Marcos**. **Donald**, from Argentina was the big surprise, with his musicality and informal manner. The foreign delegates were very appreciative of **Os Originais do Samba**, typically Brazilian ensemble. Present at the event were **Mr. Vias Jr.**, (Regional Manager for Latin America-Recording Division), **Mr. Jones** (President of R.C.A. of Brazil) and **Mr. Jackson** (Vice-President of R.C.A. for Latin America).

## JULY

After having headed for twenty years several departments of the biggest diskeries in this country, **Alfredo Corletto** leaves his position as manager of Public Relations and Promotion for R.C.A. Victor and become its artistic director. The **Associação Brasileira dos Produtores de Fonogramas** (Brazilian Association of Disk Producers) has a new

staff of elected members in its Directing Council: **Joao Rabmi** (from Cassio Muniz S.A.) is the President; **Hans P. Beugger** (from Industrias Electrica e Musicais Fabrica Odeon S.A.) **David W. Jones** (RCA S.A.) and **Antonio Pinheiro da Silva** (Discos CBS S.A.) are the directors; **Sebastiao R. Bastos** is the new executive director.

**Chantecler** diskery has imported some very important classical international music from the USSR (Mezhduranodnaya Kniga), USA (Decca) and Italy (Ricordi).

## AUGUST

**Marcos** and **Paulo Sergio Valle**, the famous brothers, have launched a new LP: "Mustang Cor de Sangue ou um Corcel cor del Mel," which features several potential hits such as: "Mustang Cor de Sangue", "& Os dentes Branco do Mundo" and "Evangelho Segundo San Quentin". **Marcos Valle** has performed in the U.S.A., where he lived for 2 years.

The **Chantecler** classical music imports are selling at such a rate that this diskery is planning on bringing a whole new series from foreign countries and on promoting Brazilian artists. The success of this initiative was quite surprising since the Brazilian public for this kind of music is quite small.

## SEPTEMBER

The most important event in Sept-

ember was the IVth International Fest of the Popular Song, which took place in Rio, from September 25 to October 6. The headquarters were at Hotel Gloria and the shows were held at Maracanazinho, a stadium turned into an enormous theater. This fest is especially known for its uninhibited and involved audience, which applauds deliriously any music it appreciates and boos mercilessly anything that doesn't suit its whims. In the national phase, the popular vote chose: 1 — **Cantiga por Luciana** by **Edmundo Souto** and **Paulinho Tapajos**; 2 — **Razao de Paz Para Nao Cantar** by **Edmundo Lage** and **Alesio de Barros**; 3 — **Juliana** by **Antonio Adolfo** and **Tiberio Gaspar**. The jury voted: 1 — **Cantiga Por Luciana**; 2 — **Juliana**; 3 — **Visao Geral** by **Cesar Costa Filho**, **Ruy Mauriti** and **Ronaldo Monteiro de Souza**. As to the International phase, the popular vote chose: 1 — **Cantiga Por Luciana** (Brazil); 2 — **Love Is All** (Great Britain) by **Les Reed** and **Barry Mason**; 3 — **Evie** (USA) by **Jimmy Webb**. The jury voted: 1 — **Cantiga Por Luciana**; 2 — **Evie**; 3 — **Love Is All**.

## OCTOBER

Right after the IVth International Popular Song Fest in Rio, a hard cover LP with many songs of the National Phase was launched by **CBD** (Philips) — a live recording. Following this, the

same diskery, also with the Philips label, put into the market an LP with 13 of the 40 competing songs of the International Phase.

**Fermata** diskery also launched an LP with several Fest songs of the National and International phases.

**RCA** put forth **Martinho da Villa's** "Madrugada, Carnaval e Chuva," which competed in the IV International Fest, in a single compact which is expected to hit it just as his LP did.

## NOVEMBER

The just released sound track of the film "Capitães da Areia," based on the novel by **Jorge Amado**, features the well-known **Eliana Pittman** singing **Dorival Caymmi's** composition.

"Love Is All" sung by **Malcolm Roberts** in the Rio Song Fest (3rd place) is the hit parade leader in Sao Paulo, after an extremely fast rise. This is a **Fermata** launching, published by **RCA**. **RCA** released an LP with **Os Incriveis**. **Philips** showed its new catalog which included the first LP by their new artist, **Chico Buarque de Holanda** who will be sending composition from Italy.

The heads of **Continental Records** **Alberto Jackson**, **Byington Neto** (President), **Miguel Gomez Campodarve** (Superintendent) and **Wilson Rodrigues Poso** (Commercial Manager), visited the USA and Latin America and wound up with the representation for Continental of two American labels and the launching of 15 Brazilian productions in foreign countries.

## DECEMBER

**RCA** hosted a cocktail in honor of **Martinho Da Villa** ("Quem E do Mar Nao Enjoa") and **Nilton Cesar** ("Férias na Índia"), and both were awarded with a golden record, **Fermata** released an LP of **Vanity Fare**. The launching was quite successful and opened up to the English group the Brazilian market, that usually record Page 1.

Brazilian diskeries start launching and promoting LP's with compositions for the coming carnival. The most popular ones will be played in every club and theatre during the four days.

## JANUARY

**Gal Costa** awarded with a prize offered by the press and is performing a show in Sao Paulo and Belo Horizonte together with **Macale** and **Som Beat** and **Lanny**. **Gal Costa** and **Macale** have a new manager and started business on their own.

**Eli Regina** also awarded with the prize "Governor of the State". **Philips** launched the LP "Jorge Ben vai bem" a hitter by the famous artist who was so successfully applauded in **MIDEM**.

Two Brazilian singers very successful at **MIDEM** - **Jorge Ben** and **Wilson Simonal**.

## FEBRUARY

**Chico Buarque De Holanda**, **Cetano Veloso** and **Gilberto Gil**, three of the most important singer-composers of Brazil, now living in Europe, con-

## FRANCE: The Past 12 Mos.

(Con't. from Page 74)

ed very slowly then was continually played in discotheques around the country. Now the record is taking off in several countries . . . **Tino Rossi** and **Gilbert Becard** signed with **Pathe Marconi** again. **Tino Rossi** has been with **Pathe** for over 36 years . . . **Pathe Marconi** now releasing in France **Scepter Wand** and **Straight** . . . **Fran-**

**coise Hardy** who is about to leave **Vogue** is being sought by all the other major record companies . . . **Jean-Paul Guitier** getting the first prize from the **Academie du Jazz** for his fabulous **De Luxe** set of **Fats Waller's** recordings . . . **Barbara Baker** who left **Decca** **RCA** to join **Disc'Az** at the head of the international division arrives at about the same time as **Jo Milgran** sales manager who left **Barclay** for **Disc' Az**. Soon after the arrival of those people to **Disc' Az**, the French company

started getting hit after hit: **Michael Polnareff**, **Shocking Blue**, **Georgio** ("Looky Looky").

**DECEMBER:** **Adamo** sold over 30,000,000 records all over the world . . . "My Way," a French song by **Jacques Revaux**, published by "Les Nouvelles Editions Barclay" a hit all over the world following **Sinatra's** recording . . . **Michel Delorme** who was handling the import department at **Pathe Marconi** imported 23,000 LPs in October, 26,000 in November and 37,500 in December. From December 68 to December 69 import improved: 143% Success for **Creedence Clearwater Revival** continued week after week. The **Phillipe Thomas** managed company, **Musidisc**, making quite a lot of money with the **Creedence** . . . **Lucien Ades** sold over 1,000,000 records through his company during the year. **Lucien Ades** releases the **Walt Disney** label . . .

**JANUARY:** The **Aphrodite's Child** sold 46,000 singles of "It's Five O' Clock" between January 8th and 12th . . . **Chappell** opens its pop division now headed by **Michel Larmand** at 124 rue La Boetie . . . **Pelgrins De Bigard** now definitely heading **Decca** . . . **Francoise Hardy** has settled her problems with **Vogue**. She is looking for a new outlet . . . **Ted Insley** heading R.C.A.: the new-look R.C.A. starts on July the 1st . . . 4,000 sets of **Fats Waller's** recordings sold within two months . . . And again, January is the month of the **Midem**. This year it will definitely make a success out of the **Bernard Chevy's** venture. Every-

(Con't. on Page 87)

## HOLLAND: The Past 12 Mos.

(Con't. from Page 80)

**Miles Davis**, **Cecil Taylor**, **Lionel Hampton** etc. very successful. Soul-concerts in The Hague and Amsterdam with **Arthur Conley** and **Percy Sledge**.

## DECEMBER

Release by **Colossus** in the US of 'Venus' (**Shocking Blue**). **Bovema** acquired the 'Fantasy' and 'Wergo' labels. **Basart Records International** had a very successful release of a Turkish LP. Immense sales for **Stones** album 'Let It Bleed'. US top-act **Sir Douglas Quintet** visited Holland to do a concert and a TV-show. **Francoise Hardy** featured artiste in a TROS TV-show. **Robin McBride** of **Mercury Records**, Chicago, visited Holland for talks with various execs of **Phonogram** and **P.P.I.** Tremendous success for **Chicago** during Amsterdam concert.

## JANUARY

**CNR's** president **Hans van Zeeland**

strengthens the position of his company on the Dutch market with acquiring the distribution rights of **Ariola**, one of the leading German firms. **Shocking Blue's** 'Venus' became no. 1 in the U.S., and in most countries around the world. **Shocking Blue's** 'Mighty Joe' in Holland no. 1. Foundation of **Ariola-Eurodisc-Benelux N.V.**, of which **Jan van Schalkwijk** became president. **Iwan Rebroff** and **The Pattersons** on TV. **Arlo Guthrie** visited Holland for promotion of his first film 'Alice's Restaurant' and his album 'Running Down The Road'. Many personalities of Dutch record-companies and music publishing houses were present at **MIDEM** in Cannes. **Phonogram** started new-promo-campaign on the Island label. **John Mayall** concerts in Rotterdam and Amsterdam. **Colosseum** (**Vertigo**) and **Samantha Jones** (**Penny Farthing**) in Holland for TV-show. Dutch group **Ekspection** performed with the North

(Con't. on Page 86)



**COPYRIGHT IN BRAZIL**

**WE ARE CELEBRATING TOO!**

**S.I.C.A.M.**

**COMPLETES ITS**

**10TH FOUNDATION ANNIVERSARY**

**July 7, 1960 to July 7, 1970**

**S.I.C.A.M.**

**SOCIEDADE INDEPENDENTE DE COMPOSITORES**

**E AUTORES MUSICAIS**

**DEVELOPING AUTHORS, COMPOSERS, PUBLISHERS**

**INTERESTS IN BRAZILIAN PERFORMING RIGHTS**

**LARGO PAISSANDU, 51 — 11<sup>o</sup> — SAO PAULO — BRAZIL**

# We Represent In Brazil:

**MCA** (U.S.A.) / **FUENTES** (COLOMBIA) / **FESTIVAL** (FRANCE)  
**METRONOME** (GERMANY) / **MEZHKNIGA** (U.R.S.S.)



# CHANTECLER

RUA AURORA 1011 P.O.B. 478 SAO PAULO BRAZIL

**we made these Records big hits in Brazil:**

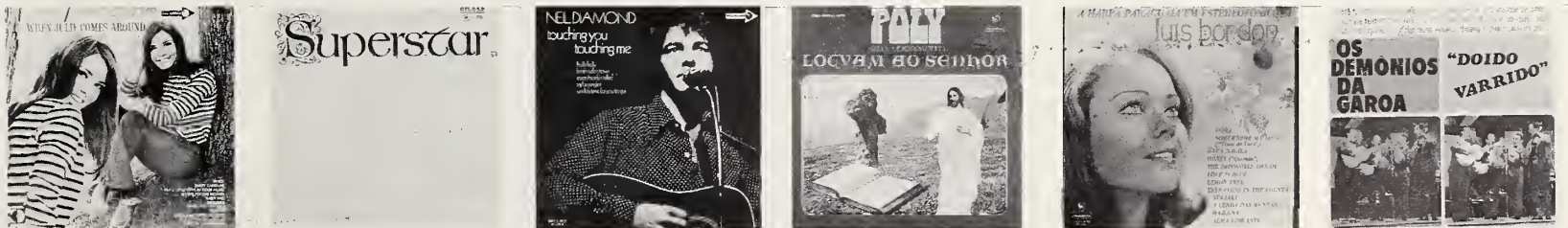

# BRAZIL'S MUSIC PUBLISHERS

## PUBLISHERS AFFILIATED WITH SICAM

**HARMONIA**  
Rua Osorio Duque Estrada 134 (Sao Paulo)

**MUSICORDE**  
Rua Osorio Duque Estrada 138 (Sao Paulo)

**SONATA**  
Av. Ipiranga 1123 (Sao Paulo)

**BRAMBILLO**  
Av. Parada Pinto 698—Barra Funda (Sao Paulo)

**ARLEQUIM**  
Av. Ipiranga 1123—7º and. (Sao Paulo)

**MUSICLAVE**  
Av. Ipiranga 1123—5º and. S/504 A (Sao Paulo)

**SATURNO**  
Av. Rio Branco 311—6º S/610 (Rio de Janeiro)

**MUSICAM**  
Rua Francisco Serrador 90—grupo 1802 (Rio de Janeiro)

**INSPIRACAO**  
Rua do Arouche 42 (Sao Paulo)

**JEQUIBAU**  
Rua Atlantica 697 (Sao Paulo)

**EBRAU**  
Rua Siqueira Campos 143—loja 135—(Rio de Janeiro)

**TOCATA**  
Rua Aurora 964 (Sao Paulo)

**FERMATA**  
Av. Ipiranga 1123 (Sao Paulo)

**ALDEM**  
Pca. Florian 55—7º and. (Rio de Janeiro)

**MUSIRAMA**  
Av. Ipiranga 1123—4º and. S/403 (Sao Paulo)

**SIDOMAR**  
Av. Ipiranga 1097—9º and. (Sao Paulo)

**RCA-JAGUARE**  
Av. Ipiranga 1097—7º and. (Sao Paulo)

**AVANCO**  
Av. Sao Joao (diskshop) (Sao Paulo)

**GAPA**  
Av. Rio Branco 311—4º and. 403 (Rio de Janeiro)

## PUBLISHERS AFFILIATED WITH UBC

**ATA EDICOES MUSICALS**  
Rua Vic. de Inhauma, 107—3º andar—GB

## PUBLISHERS AFFILIATED WITH UBC

**BANDEIRANTE EDITORA MUSICAL LTDA.**  
Rua Seminario, 165—2º S/4 (Sao Paulo)

**CANNES EDITORA MUSICAL LTDA.**  
Pca. Mahatma Gandhi, 2 S/805—GB

**COMPACTO EDITORA MUSICAL, DISCOS LTDA.**  
Rua 29 de Julho, 158—GB

**COPACABANA MUSICAL LTDA.**  
Rua do Resende, 18—1º andar—GB

**CRUZEIRO MUSICAL LTDA.**  
Rua Visc. de Inhauma, 107—3º andar—GB

**EDICOES MUSICALS FONTANA LTDA.**  
Av. Rio Branco, 311—6º and.—GB (Philips)

**EDITORIA ARTHUR NAPOLEAO LTDA.**  
Av. Ipiranga, 1123—5º and. (Sao Paulo) (Fermata)

**EDITORIA DRINK LTDA.**  
Av. Ipiranga, 1123—5º and. (Sao Paulo)

**EDITORIA GANDELMAN LTDA.**  
Rua Republica do Libano, 16—GB

**EDITORIA MUSICAL GRAGATOA LTDA.**  
Rua do Rosano, 170—Grupo 301/302—GB

**EDITORIA MUSICAL BRAZANO LTDA.**  
Rua Visc. de Inhauma, 134—7º and.—GB

**EDITORIA MUSICAL ARLEQUEM LTDA.**  
Av. Ipiranga, 1123—7º and. Q/702—S.P. (Fermata)

**EDITORIA NOSSA TERRA LTDA.**  
Rua Santa Luzia, 799—3º and.—GB

**EDITORIA MAUA LTDA.**  
Rua Visc. de Inhauma, 134—7º and. S/707—GB

**EDITORIA LITERO MUSICAL CORCOVADO LTDA.**  
Rua do Resende, 18—1º and.—GB

**EDITORIA LATINO AMERICANA MUSICAL "ELAM LTDA."**  
R. Visc. do Rio Branco, 53 Loja—GB

**EDITORIA MUSICAL BRASILEIRA LTDA.**  
Rua Santa Luzia, 799—S/304—GB

**EDIT. MUSICA BRASILEIRA MODERNA LTDA.**  
Av. Ipiranga, 1123, 5º and. (S. Paulo) (Fermata)

**EDITORIA MUSICAL PLANALTO LTDA.**  
Pca. Mahatma Gandhi, 2, 9º and. S/906—GB

**EDICOES MUSICAIS SAMBA LTDA.**  
Rua General Gustavo Cordeiro de Faria, 573—GB

**EDICOES MUSICAIS VICTOR LTDA.**  
Av. Ipiranga, 1097—10º and. (Sao Paulo)—RCA

# BRAZIL'S RECORD COMPANIES

**SOM INDUSTRIA E COMERCIO LTDA — COPACABANA**  
Av. Paulista, 1009-22º Sao Paulo  
General Manager: Emilio Vitalte

**RCA ELECTRONICA BRASILEIRA S.A.**  
Av. Ipiranga, 1097 Sao Paulo  
General Manager: David Jones

**INDUSTRIAS ELETRICAS E MUSICAIS FABRICA ODEON S.A.**  
Av. Rio Branco, 277-4º Rio de Janeiro  
General Manager: Henry Jensen

**GRAVACOES ELETRICAS S.A. — DISCOS CONTINENTAL**  
Rua 7 de Abril, 59-8º Sao Paulo  
General Manager: Wilson Rodrigues

**FERMATA DO BRASIL LTDA.**  
Av. Ipiranga, 1123 Sao Paulo  
General Manager: Enrique Lebendiger

**DISCOS CHANTECLER (CASSIO MUNIZ S.A.)**  
Rua Aurora, 1050 Sao Paulo  
General Manager: Joao Ribeiro

**COMPANHIA BRASILEIRA DE DISCOS (PHILIPS)**  
Av. Rio Branco, 311-4º Rio de Janeiro  
General Manager: Andre Midani

**CBS DO BRASIL S.A. — INDUSTRIA E COMERCIO**  
Av. da Liberdade, 1046 Sao Paulo  
General Manager: Evandro Ribeiro

## PUBLISHERS AFFILIATED WITH UBC

**EDICOES MUSICAIS FONTANA**  
Av. Rio Branco, 311—º and.—GB (Philips)

**EDICOES MUSICAIS FALCAO**  
Rua Otavio Correia, 202 ap. 102 (Urca)—GB

**EDITORIA MUSICAL ROMANCE LTDA.**  
Rua Visc. de Inhauma, 107—3º and.—GB

**EDITORIA MUSICAL PAO DE ACUCAR LTDA.**  
Rua do Rosario, 170 Or.301/302—GB

**EDICOES TIGER MUSICA E DISCO**  
Rua Visc. de Inhauma, 134—S/733—GB

**EDICOES M.R. LTDA.**  
Rua Visc. de Inhauma, 134—S/753—GB

**EDICOES NESLSON TRIGUEIRO**  
Av. Nilo Pecanha, 766 (NOVA IGUACU) Est. do Rio

**EDICOES OUVIDOR LTDA.**  
Rua do Resende, 185—GB

**EDICOES CLAVE MUSICAL LTDA.**  
Rua General Gustavo Cordeiro de Faria, 545—GB

**FERMATA DO BRASIL LTDA.**  
Av. Ipiranga, 1123—5º and. (Sao Paulo) (Odeon)

**MELODIA S AMERICANAS LTDA.**  
Av. Ipiranga, 1123—5º and. (Sao Paulo)

**LEBLON MUSICAL LTDA.**  
Rua Santa Luzia, 799—S/304—GB

**MELODIAS POPULARES LTDA.**  
Rua Santa Luzia, 799, 3º and.—GB

**RIO MUSICAL LTDA.**  
Rua Visconde de Inhauma, 134—S/321—GB

**RITMOS EDICOES MUSICAIS LTDA.**  
Av. Rio Branco, 277—15º and. sala 1505—GB

**RICORDI BRASILEIRA S/A**  
Rua Conselheiro Nebias, 777—Sao Paulo

## PUBLISHERS AFFILIATED WITH UBC

**SMART EDITORA MUSICAL LTDA.**  
Av. Ipiranga, 1123—oonj. 901 (Sao Paulo)

**PAGE EDICOES MUSICALS LTDA.**  
Rua Paisandu, 162, ap. 702—GB

**TODAMERICA MUSICA LTDA.**  
Rua Santa Luzia, 799—3º and.—GB

**TOP EDITORA MUSICAL LTDA.**  
Rua Visc. de Inhauma, 134—7º and. S/705—GB

## PUBLISHERS AFFILIATED WITH SADEMBRA

**IRMAOS VITALE S/A**  
Rua Franca Pinto, 42

**MANGIONE & FILHOS**  
Rua Cel. Batista da Luz, 26

**CASAS EDITORAS MUSICALS BRASILEIRAS REUNIDAS "CEMBRA LTDA."**  
Av. Prestes Maia, 220—15º andar

**MUSIBRAS EDITORA MUSICAL**  
Av. Ipiranga 1123

**SERESTA EDITORA MUSICAL**  
Av. Ipiranga 1123

**NOTAS MAGICAS EDITORA MUSICAL LTDA.**  
Av. Ipiranga 1123

**EDICOES MUSICAIS RCA.**  
Av. Ipiranga 1097—7º andar

**RICORDI BRASILEIRA S.A.E.C.**  
Av. Conselheiro Nebias 177

THE FERMATA GROUP — AV. IPIRANGA, 1123, SAO PAULO, BRAZIL

THESE LABELS ASSURE YOU  
THE BEST RECORDS  
IN BRAZIL







# GRAVACOES ELETRICAS S.A. (DISCOS CONTINENTAL)

RELEASES IN BRAZIL THE SAME WAY METROMEDIA RE-  
LEASES IN U.S.A. THE WORLD'S FIRST SELF-DESTRUCT  
RECORD ALBUM.

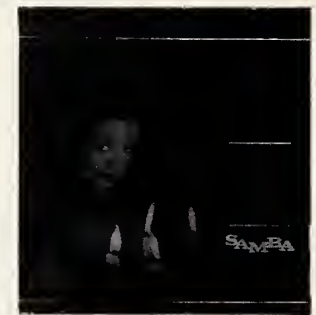
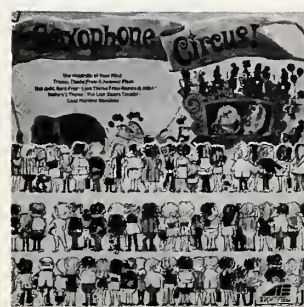
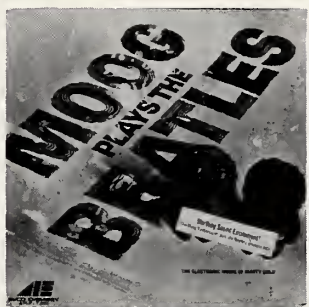

## CONTINENTAL PRODUCTIONS.

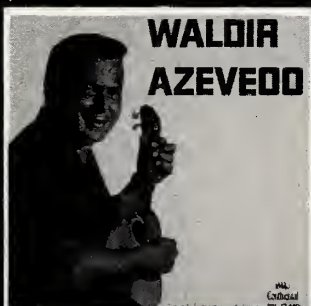
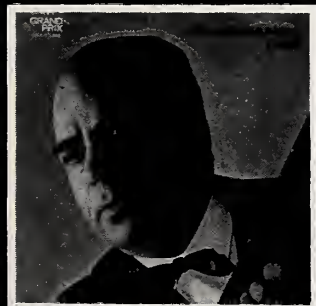

GRAVACOES ELETRICAS S.A.  
(DISCOS CONTINENTAL)  
SAO PAULO — BRAZIL

### CONTINENTAL

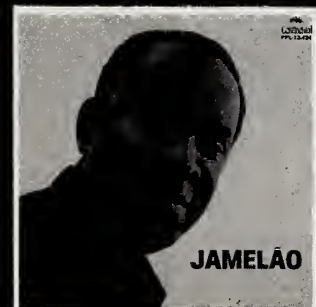

MAIN OFFICE  
Rua 7 de Abril, 59 — 8º andar — Tel.: 37-3215 —  
37-5439  
BRANCH — RIO DE JANEIRO  
Rua Pedro Lessa, 35 — 7º andar — Tel.: 232-3141  
PLANT  
Avenida do Estado, 4755 — Tel.: 35-3574  
CABLE ADDRESS: Contaldiscos  
TOTAL NUMBER OF PRESSES: 35  
WE ARE MAKING PRESSINGS FOR: C.B.S.,  
CHANTECLER (MCA), CARAVELLE, BEVERLY  
EBRAU — (MOTOWN — BARCLAY) PLUS 62  
OTHER LABELS

## HOLLAND: The Past 12 Months

(Con't. from Page 82)

Holland Symphony Orchestra at the Haarlem Opera House. 2nd performance in Holland of the Who's pop opera 'Tommy'. Robert Oeges appointed adjunct managing director of Polydor. Dutch famous organist Feike Asma signed with RCA. Polydor started distribution of the Action label.

### FEBRUARY

The annual 'Grand Gala Du Disque', on the 27th in Amsterdam turned out to be the biggest and best organized European event of the year. Stars of the show were Jose Feliciano, Sergio Mendes, Anita Kerr Singers, Heintje, James Last, Nana Mouskouri and Edwin Hawkins Singers. A few days before the Grand Gala CNR's president Hans van Zeeland offered 7 gold records to the youngest artist of Holland, 14 year old Heintje, for selling over ten million of records. This happened in a charterplane, 30,000 feet high at presence of the complete Dutch writing, talking and filming press. Tour of Dozy, Beaky, Mick & Tich. Ekseption received a Golden Record for their first Philips-album, which sold well over 50,000. Cilla Black topping the bill in a popular Saturday night TV-show. Edith Jovitz, execu-

tive manager of Buddah's foreign dept. visited Holland to discuss promotion with Rein Maassen, president of Barclay Holland. Elbert van Zoeren joined Holland Music as General Manager. Jan van Schalkwijk was leader again of the Dutch team of the Coupe d'Europe Songfestival in Bern, organized by Erich Reindl. The female vocal group 'Hearts of Soul' won the first prize during the Dutch finals of the Eurovision songcontest with 'Waterman'. Jerry Ragni and Jim Rado received the Dutch Edison for their 'Original Broadway Cast Of Hair'. 'Soul Together' shows in Amsterdam and Rotterdam, with Sam & Dave, Arthur Conley and Joe Tex. Polydor signs contract with group Amsterdam. Atlantic star Roland Kirk gave concerts. Polydor signed contract with the Festival-label. CNR's promotion manager Gert van der Meent gave a hearty welcome to one of the managers of the Russian Melodia firm, Mezkniga, Mr. Saitsef.

### MARCH

Eurovision Song Festival in Amsterdam with Dana from Ireland as the winner. Dutch singer Lenny Kuhr touring in France with George Brassens. Singer Shirley Zwerus left for New York to record for Canyon Records, Inc. French vocalist Enrico

Macias in Holland to record his own 45 minutes TV-show. Ekseption's record 'The Fifth' hit the no. 1 spot in France. Reported sales passed the 250,000 mark. Therese Steinmetz won the first prize at the Golden Deer Festival in Brassov, Rumania. Golden Earring returned from an extremely successful 6 months tour in the U.S. U.S. Mercury star Jerry Butler in Holland for the 'Jam' TV-show. 35 years anniversary of the Kilima Hawaiians. The Edwin Hawkins Singers returned from Italy and did three live performances. The one at the Concertgebouw in Amsterdam was recorded and released in Holland, Belgium and England. Dureco launches new record-label: Blue Elephant. Polydor introduced the new Blossomlabel; first release "She Was Naked" by Super Sister became a big hit. A Dutch independent production company entrusted their products to CNR: Armada Records gave its distribution rights to this company and started working with the CNR promotion team. Polydor recorded the Dutch cast of 'Hair', and started jazz-action for the catalogues of Atlantic, Chess, Storyville, Riverside and Verve. Melanie and her producer Peter Schekeryk came to Holland to set up the release of and to promote the third Melanie album 'Candles In The Rain'. Melanie also gave three sell-out concerts in Amsterdam, Rotterdam and The Hague. Barclay Holland/CNR was very proud to give to Melanie two gold albums. Vox Productions appeared on the Dutch market with musicassettes with a playing time of 2 LP's.

### APRIL

Dutch pirate station Radio Veronica celebrated its 10th anniversary. Phonogram took action against a Rolling Stones bootleg album and eventually succeeded in stopping the sales of bootleg records with the official retailers. Margit Schramm concert in Rotterdam big success. Bovema's popgroup Brainbox toured Europe together with Creedence Clearwater Revival. Bospel Music made a deal with Ed. Gerard Tournier, Paris, with as result that Bospel Music gets a lot of French catalogues and various American catalogues (a.o. Trousdale Music) in its possession. Los Incas 'El Condor Pasa' (Philips) was a very unexpected hit in Holland. Dureco's young singing star Wilma off to England for recordings in English language. Isaac Stern concerts in Amsterdam and Rotterdam. Salena Jones, It's A Beautiful Day, Johnny Winter, The Flock and Taj Mahal in Holland for concerts and TV. Phonogram launched

the double LP cassettes on the Dutch market. The cassette holds two albums on tape and raitails at 33 guilders (\$9). British underground-act Black Sabbath did a 50-minute TV-show. Phonogram released the first records on the UNI label, which was recently acquired through Philips Phonographic Industries. Negram reported international success for the new singles of the George Baker Selection ('Dear Ann') and Tee set ('If You Do Believe In Love') while both groups completed albums for the American market: Juliette Greco did an extensive tour of Holland and Lulu did a TV-show. Mr. Ralph Peer II, vice president of the World Organization of Peer-Southern U.S.A., together with Bob Kingston from the London office, visited the Netherlands for business talks with Holland Music boss Han Dunk. Capitol Records presented the 'Country Music Caravan'-show starring Buck Owens, Tex Ritter, Wanda Jackson etc. in Amsterdam. Big success for Ekseption at the Montreux TV-Festival.

### MAY

For the first time in Holland an international famous artist appeared in a stadium; it was Jose Feliciano who appeared for about 30,000 very enthusiastic fans. Also a very successful concert in Amsterdam for Simon & Garfunkel and Leonard Cohen. Bovema acquired the 'Amaret' catalogue. Dutch popgroup Opus appeared in BBC's 'Top Of The Pops'. First releases by Bovema on the 'Invictus' label. The Band of the Royal Dutch Airforce made their first intercontinental trip to Canada; the director of the band, major H. van Diepenbeek, became honour-citizen of Winnipeg. D.C. Lewis was awarded with a Golden Record for his 100,000 selling record 'Mijn Gebed' (My Prayer) on the Philips-label. Phonogram's managing director Jack Haslinghuis awarded the cast of Dutch TV-series 'Het Schaep Met De Vijf Pooten' with Golden Records. Merrymen in Holland for promotion. This month Inelco made special campaigns for Arthur Rubinstein, Elvis Presley, Eugene Ormandy and the MCA C&W Tour. Eugene Ormandy and the Philadelphia Orchestra were in Rotterdam, supported by very much promotion. Roy Black did a concert in Kerkrade. Three successful concerts of John Mayall and Herbie Mann recorded a radioconcert. Bospel Music got the representation of Blanch Music Publ., New York. John Mayall gave his farewell concerts with his 11th group in Amsterdam, Rotterdam and The Hague. Bovema's popgroup Unit Gloria performed in the Hollywood Palladium.

### Greetings from FELIX STAHL

the only Scandinavian composer whose songs have been recorded by international stars, such as:

Sweden: Bibi Johns. U.S.A.: Eddie Fisher, Rosemary Clooney, Percy Faith. Great Britain: Frankie Vaughan, Gracie Fields, Kim Cordell, Dave Clark Five, Jackie Trent, Johnny Tudor. Italy: Teddy Reno. France: Tino Rossi, Franck Pourcel, Caravelli. Germany: Britt Malmkjell, Ray Martin.

And Now Watch For "No Time Like Now, My Love"

# STOCKHOLMS MUSIKPRODUKTION

Drottninggatan 55. S-11121 Stockholm, Sweden.

## CORPORACION LATINOAMERICANA DEL DISCO C.A. APARTADO 70232 CARACAS, VENEZUELA

### DISTRIBUTORS

of

## RCA RECORDS STEREO 8 AND CASSETTES

## BRAZIL: The Past 12 Mos.

(Con't. from Page 82)

tacted by a Philips producer - Manuel Berenbein for the cutting of three LP's to be launched in Brazil in May. Some of the most important diskeries have their vacations in February; this is also a month of low sellings due to school vacations and carnival.

### MARCH

Mr. Johnson, vice-president of MCA, came to Brazil to renew MCA's contract with Chantecler and to see the launching of "Superstar" by Murray Head, a single that hit the charts for several months.

### APRIL

Elizeth and Zimbo Trio on April 12 fly to United States, invited by Minister Mario Gibson Barbosa, for a cultural tournee. They'll be presented first of all at the OEA building in Washington, after this they'll be going to New York city, Chicago, Boston, San Francisco, and Los Angeles. For this tour Zimbo Trio has prepared 60 Brazilian songs mainly of the composers Chico Buarque De Hollanda, Edu Lobo, Milton Nascimento, Baden Powell, Marcos Valle, Caetano Veloso and Gilberto Gil. Elizeth and Zimbo Trio are happy for this chance to be presented in the US especially for the young audience

who has always applauded them. Jorge Ben and Trio Mocoto are still having a tremendous success at Boite Sucata in Rio de Janeiro, where they have started as main protagonists of the film "Algo Mais em Sua Vida" ("Something Else in Your Life"), sound track by Jorge Ben. May 20, there in Lisbon for the Portuguese Song Fest.

Chico Buarque De Hollanda back in Brazil is preparing with MPB4 his presentation at Boite Sucata in Rio de Janeiro, planned for April 14.

### MAY

Joelma, a singer who became famous with "Aqueles Tempos", a version of "Those Were The Days", that is selling well, especially in the country, signed a contract with Discos Continental. A tour with Joelma is programmed all through Latin America starting in Mexico. Jose Claudio, international producer of Chantecler, informs the next launchings: three singles that soon will be in the Brazilian charts: "Airport Love Theme" - Vincent Bell, "Run Sally Run" - Cuff Links and "Easy to Be Free" - Rick Nelson.

The most important LP's are: The 4th LP of Segovia playing bach, a catalog LP of the famous guitar player, "Jealous Kind of Fella" - Garlar Green and a sure hitter "Touching You and Touching Me" - Neil Diamond, Diamond, CBS launched a single, "Cecilia" by Simon & Garfunkel.

# BRAZIL'S RADIO STATIONS

## SAO PAULO

**ASSOCIACAO DAS EMISSORAS DE SAO PAULO (AESP)**  
Praça da Republica, 386-7<sup>o</sup>

**AMERICA**  
Radio America S.A.  
Rua Radiantes, 13

**BANDEIRANTES**  
Radio Bandeirantes S.A.  
Rua Radiantes, 13

**CULTURA**  
Radio Cultura S.A.  
Rua 7 de Abril, 230-14<sup>o</sup>

**ELDORADO**  
Radio Eldorado Ltda.  
Rua Major Quedinho, 76-7<sup>o</sup>

**GAZETA**  
Fundacao Casper Libero  
Av. Paulista, 900

**MARCONI**  
Radio Sociedade Marconi Ltda.  
Rua Santa Tereza, 20-19<sup>o</sup>

**NACIONAL**  
Organizacao "O Globo"  
Rua das Palmeiras, 315  
9 De Julho

**PANAMERICANA**  
Radio Panamericana S.A.  
Av. Miruna, 713

**PIRATININGA**  
Radio Emissoras de Piratininga Ltda.  
Rua 24 de Maio, 208-10<sup>o</sup>

**TUPI**  
S.A. Radio Tupi  
Rua 7 de Abril, 230-14<sup>o</sup>

**RECORD**  
Radio Record S.A.  
Av. Miruna, 713

**SANTO AMARO**  
Radio Difusora Hora Certa Ltda.  
Praça da Liberdade, 61-8<sup>o</sup>

**SAO PAULO**  
Radio Sao Paulo S.A.  
Av. Miruna, 713

## RIO

**CONTINENTAL**  
Sociedade Radio Emissora Continental Ltda.  
Rua Riachuelo, 48

**ELDORADO**  
Radio Eldorado Ltda.  
Av. Pres. Vargas, 417-12<sup>o</sup>

**GUANABARA**  
Av. 13 de Maio, 23-25<sup>o</sup>

**GLOBO**  
Radio Globo S.A.  
Rua Irineu Marinho, 35-4<sup>o</sup>

**JORNAL DO BRASIL**  
S.A. Radio Jornal do Brasil  
Av. Rio Branco, 110-5<sup>o</sup>

**MAUA**  
Fundacao Radio Maua  
Av. Pres. Antonio Carlos, 351-2<sup>o</sup>

**METROPOLITANA**  
Soc. Radio Emissora Metropolitana Ltda.  
Rua Riachuelo, 48

**MUNDIAL**  
Radio Mundial S.A.  
Av. Pres. Vargas, 417-12<sup>o</sup>

**NACIONAL**  
Praça Maua, 7-10<sup>o</sup>

**RIO DE JANEIRO**  
Organizacao Radio Copacabana Ltda.  
Av. Rio Branco, 277-18<sup>o</sup>

**TAMOIO**  
Radio Tamoi S.A.  
Av. Venezuela, 43

**TUPI**  
S.A. Radio Tupi  
Av. Venezuela, 43

FRANCE: The Past 12 Mos.

(Con't. from Page 82)

body seemed pleased about this Midem. Bernard Chevry pleased about the success of his first classical Midem . . .

**FEBRUARY: LIBERTY/UA FRANCE** has just released on a nearly worldwide basis a remarkable LP: "The Best Of France," which presents the best works from some of the top composers in France. Reaction from the public is very very good . . . Musidisc has made a 67.5% rise in its export sales in 1969. Rise for the French market is 30% . . . Philips enjoying a very big success with the Ekseption's "5th Symphony" and with The Aphrodite's Child . . . Polydor recording many Italian stars: Bobby Solo, Berti . . . Annie Cordy and Zizi Jeanmaire join C.B.S. C.B.S. also signed the Italian catalogue C.G.D. . . . Jack Robinson signed the Fred Neil catalogue. . . . Disque Fleche signed a deal with Jimi Hendrix productions . . .

**MARCH:** Alain de Ricou has been appointed head of Les Editions Pathe Marconi and Eco Music both publishing companies of the EMI group . . . "Concerto Pour Une Voix" released through Disc'AZ in France and produced by Rene Boyer's Fantasia Music a surprise hit. The record is being released in Italy, Belgium, Holland, Germany, England, Mexico, Brasil . . . 40 countries are releasing the soundtrack from the hit film: "Le Passager De La Pluie" sung by Severine . . . Claude Pascal publishing Tzeinerlin's hit in France and England . . . Mick Michel and Jocelyne Jocia signed with P.D.G. . . . Polydor renewing its deal with King Records . . . L'Academie Charles Cros gave its annual Grand Prix: Fats Waller, Nina Simone, Chicago, The Pink Floyd, Moustaki, and Gilles Vigneault among the winners . . . Over 500,000 copies sold of "Adieu Jolie Candy" . . . Macheprot records releasing an LP by the Mississipix . . . renewed their deal with Philips . . . Festival still releasing EPs by Marie Laforet in spite of departure of this singer to CBS . . . "Music For Pleasure" moves in France. The top Euro-

pean budget line LP company will market a range of LPs selling only at 11.50 francs. MFP expect to ship to 3000 retail outlets throughout France. Records are sold on 100% sale or exchange basis . . .

**MAY:** Outside the regular production of standard production of standard production companies, a young independent, showed during the year a particularly important production: Norbert Saada's La Compagnie. Saada signed with MCA, at last Midem, a distribution deal. And ever since La Compagnie released in France: On the Americ 70 Jazz label: LP's by Ella Fitzgerald, Count Basie, Billie Holiday, Art Tatum, Glen Miller, Benny Goodman, King Oliver, Armstrong. On the Americ 70 Rock label: LP's by Buddy Holly, Bill Haley, Brenda Lee. On the Classic label: 3 LP's by Segovia. And a new series Rock n'Roll revival with singers by Holly, Haley, Lee, Kalin Twins . . . They also released 10 cassettes. In September Saada will put on the market 3 de luxe sets: Armstrong Story (5LPs), Jubilee Segovia (3LPs) and Golden Age Of Jazz (4LPs). Simultaneously la Compagnie on its own label has lauched: an LP and a single by Hugues Auffray, singing songs by Jean Claude Pascal, France Gall, Aldo Frank and Nicole Croisille . . . On the Crewe label: Oliver sings "Jean" and on the Carnaby Records label and LP by Spirit of John Morgan . . . On the publishing side "Melancolie," a song by J.P. Bourtayre and Glen Campbell. Two songs by Aldo Frank (one with Paul Anka) should be recorded by Frank Sinatra. And last (surely not least) Saada opened a publishing company in Italy: "Domingas." This year was a very good year for les Nouvelles Editions Barclay with the biggest success for a French song in a long time: "My Way." Recently Jacques Revaux went to the States to receive the award given to this fabulous song. Revaux wrote the song last year and it became a hit in France for Claude Francois: "My Way" at the same time was to be the best selling single in Great Britain.



**BARBARELA**  
DISCOTHEQUE

**organizes every year  
in Palma de Mallorca  
the**

**"BARBARELA DE CONJUNTOS"  
a Pop Group International  
Competition**

for any information write to:

barbarela  
edificio olivar, plaza del olivar  
palma de mallorca  
spain

# BELGIUM'S RECORD COMPANIES

## ANVERS RADIO

Yzerplein 10-Brussels  
Phone 02-18.74.00  
Director: W. Goldschmidt  
Sales Manager: M. Van den Borre  
Labels: ABC, Paramount, Telefunken, Elite, Impulse, Ducretet-Thomson, Ember, Arsa, Hebra, Command, Audio Fidelity, Fonitcetra

## ARCADE RECORDS (P.M.M.)

Pierstraat 312e-Kontich  
Phone 03-77.60.20  
Director: L.J. Van Rijmenant  
Sales Manager: Jos Verbiest  
Labels: Arcade, Cannon, Promo-Ballroom

## BARCLAY

Lombardstraat 31-Brussels  
Phone 02-11.81.97  
Director: V. Bral  
Artistic director: Vanuls  
Sales Director: J. Vandeplass  
Labels: Barclay, Riviera, Atlantic, Atco, Contillon, Buddah, Monument, M.P.S., Prestige, Canetti, 20th Century Fox, Magellan, Black & Blue, Vortex, Erato, Melodia, Classic, Chant, Chant du monde, Jubilee, Princess, Meys, Fleche, C.N.R.

## BASART

Maurice Lemonnierlaan 20-Brussels  
Phone 02-12.50.34  
Director: Alain Lelievre  
Artistic director: Tim Visterin  
Labels: Basart

## CBS-ARTONE

Boudewijnlaan 21-Brussels  
Phone 02-19.11.70  
Director: Pascal Robiefroid  
Label Manager: Francis De Vos  
Sales Manager: Joris Tyberghein  
Labels: CBS, Artone, Epic, Dot, Paramount, Palette, Festival, C.G.T., Direction, Daddellion, Barnaby, Colpix, Philmore, Harmony, Hickory, Ode, MTA, Odysy

## DISCOBEL

Regentlaan 50-Brussels  
Phone 02-13.39.45  
Director: Wener Huys  
Labels: Discostar, Telstar, Stax, Europa

## FONIOR

Koolmijnkaai 26-28-Brussels  
Phone 02-25.40.10  
Director: A.E. Palmans  
Sales Manager: Robert Dauw  
Labels: Decca, Deram, London, Major Minor, Elf Provincieen, Pink Elephant, Blue Elephant, Omega, Weekend, Vega, Lyrique pour tous, Varietes pour tous, Something else, Alhambra, Threshold

## GRAMOPHONE

Maurice Lemonnierlaan 171-Brussels  
Phone 02-12.98.15  
Director: John Kirsch  
Record Manager: Emile Garin  
Sales Manager: Jackie Swaelens  
Artistic director: Jeff De Boeck

Labels: Bell, Capitol, Columbia, Contemporary/Good time jazz, Ducretet-Thompson, Electrola, Fame, Fast-Back, His master's voice, Isarton, Markal, Odeon, Pathe, Production Francis Lemarque, Rak, Regal, Regal Starline, Schwann, Studio Two, Talisman, Trianon, Voix de son maitre, Volksplatte, Waverley, Wergo, Word Record Club, Amaret, Apple/Zapple, Blue Thumb, Carnaby, Cornet, Crewe, Dunhill, Harvest, Hobbit, Hot-Wax, Immediate, Instant, Invictus, Imperial (Holland), Parlophone, PPX International, Regal-Zonophone, Scepter, Straight Records, Transatlantic, Wand, Blue Note, Fantasy, Imperial (USA), Liberty, Rare Earth, Solid State, Sunset, Tamla Motown, Gordy, United Artists, World Pacific, World Pacific Jazz

## HEBRA

Sint Christoffelstraat 30-Brussels  
Phone 02-12.93.75  
Director: Mrs. H. Brauer  
Sales Manager: Jean Darlier  
Labels: Hebra, New Music Corporation, Blue Jeans, Vedette, Costa Brava, Carish

## INELCO

Gasthuisstraat 20-24-Brussels  
Phone 02-11.22.20  
Director: P.J. Goemaere  
Sales manager: Roger Colpin  
Artistic director: Yvon de Bie  
Labels: RCA, Kirshner, Colgems, Poppy, MCA, Brunswick, Coral, Decca US, Kapp, Congress, Four Corners of the world, Vocalion, Vanguard, Amadeo, Amanda, Amphora, Rigolo

## PALETTE

Fernand Neuraystraat 8-Brussels  
Phone 02-44.48.40  
Directors: F. Faecq and Roland Kluger  
Artistic director: Roland Kluger

## POLYDOR

Victor Hugostraat 215-Brussels  
Phone 02-33.96.90  
Director: Walter Holzappel  
Sales manager: Maurice Mertens  
Artistic director: Maurice Mertens  
Labels: Polydor, Metronome, Ricordi, MGM, A & M, Karussell, Tip, Triumph, Kama Sutra, Deutsche Grammophon, Archiv, Adees, Supraphon, Heliodor, Musique Royale, Verve, Verve-Forcast, Storyville, Riverside, Petit Menestrel, Disneyland, Vista, Enfants sages

## POLYGRAM

Victor Hugostraat 215-Brussels  
Phone 02-33-96-90  
Director: P.J. Lebbink  
Sales manager: Charles Licoppe  
Artistic directors: Daniel Poutrain and Paul Moens  
Labels: Philips, Fontana, Mercury, President, Penny Farthing, UNI, B & C, Page One, Trojan, Island, Carrere, Biram, Vertigo, Revue, Shamley, Wayside, Peachtree, Intrepid

## R.K.M.

Fernand Neuraystraat 8-Brussel  
Phone 02-44.48.40  
Director: Roland Kluger  
Sales manager: Ida Halila  
Artistic directors: Roland Kluger, Willy Albimoor, Nico Gomez

## RONNEX

Sainteletteplaats 23-Brussels  
Phone 02-28.30.07  
Director: Albert van Hoogten

## SUPREME

Grienstraat 74-Antwerp  
Phone 02-32.24.85  
Director: Jean Meeusen  
Sales manager: L. Lardinan  
Artistic director: E. Ney  
Labels: Page One, Dick James Records, Rediffusion, Pama, Music O, Ember, Dolphin, Swapfire, Republic, Fred Jack-sons Production

## SCHOTT-FRERES

Sint Janstraat 30-Brussels  
Phone 02-12.39.80  
Sales manager: Jean-J. Junne  
Labels: Harmonia Mundi, Valois, Tudor, M.M.O., Folkways, Monitor, Charlin, B.A.M., Arcophon

## VOGUE

Barthelemylaan 35-Brussels  
Phone 02-11.79.73  
Director: Roger Meylemans  
Sales manager: Leruth Jose  
Artistic director: Harry Frekin  
Labels: Vogue, Mode, Pacific, Mondo Music, Contrepoint, Pye, Warner Bros, Reprise, Roulette, Elektra, Gene Norman, Laurie, Orfeu, Belter, A.Z., Disco Disque, Safiro, Novola, Nonesuch, Taboo, Hatakliit, Everest, Bam, Victory

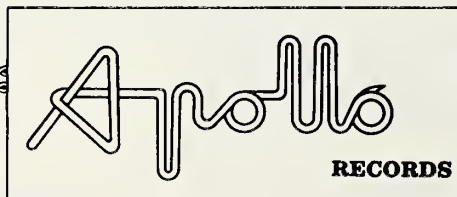

# APOLLO RECORDS s.r.l.

the new italian label

thanks

"I RICCHI E POVERI"

for the great success they had at

SANREMO'S FESTIVAL

with the song

"LA PRIMA COSA BELLA"

APOLLO RECORD s.r.l. - via guido banti, 46 - 00191 roma - tel. 3273468 - 3278103

# Forecast

## International Chart Action



# Capitol<sup>TM</sup>

# Canada - The Past 12 Months, or From Extreme Apathy To Forced Recognition

August

The month of August definitely belonged to GRT of Canada. To launch their entry into the disc market they hired one of Toronto's ferries and shipped radio, press and key dealers out on the lake for a series of concerts by newly signed Canadian groups, Eighth Day and Magic Cycle. Also on board was the Chess Checker group, Rotary Connection. Andy Kim tops the Canadian charts with his Steed lid "Baby I Love You". Dianne Leigh releases initially for Chart. Her first release "I'm Gonna Let George Do It" makes national gains. Quality to distribute Sun Line. First releases are: Jerry Lee Lewis and Johnny Cash "Greatest Hits". Bill Osbourne takes over as sales manager of the Central Division for Phonodisc. Quality Records set to distribute new Crewe line in Canada. Their first release "Jean" almost immediately established as national hit. RCA's John Pozer arranges for top exposure of label's acts at Ottawa's Fair. Polydor's Life release Canadian hit "Hands Of The Clock" in the UK. James Last into Toronto's O'Keefe Centre for sellout engagement. Also appeared at Montreal's Man & His World. The Maple Leaf System call meeting with record company execs in attempt to gain more cooperation. CHUM presents "History of Rock and Roll". This series of seven 4 hour programs is made available to other stations through the Canadian Association of Broadcaster's program exchange. Compo Company releases a CBC/Apex co-op of Neil Chotem "Plays Gordon Lightfoot". Polydor holds first national meet at Mont Gabriel Lodge in Quebec's Laurentians. Montreal's Tobias breaks with "You're Not Even Going To The Fair". Decca Records bows new logo. Russell P. Wheaton appointed general manager of Alex Sherman Music Centres. Serge Plotnikoff readys LP of originals. Baniff Records' Graham Townsend captures Shelburne Fiddling Award for fourth year straight. Capitol's Glen Campbell into Toronto for appearance at Toro to Fair. Label holds posh and well attended press reception. Capitol introduces new logo. Ray Griff breaking with Dot outing "The Entertainer". CKFH presents Drake's "History of Rock and Roll". John Driscoll joins MTCC as director of A&R.

Fingerprint's Magic Cycle given top pick by MLS stations for their entry

of "Groovy Things". Compo to distribute Straight. September was also the month that Gamma's Robert Charlebois broke into English Canada with "Lindburgh". Nimbus 9's Bonnie Dobson chalking up good sales with her album distributed by RCA. Mark Robbins appointed Ontario promotion manager for Quality Records. Melbourne's Cotter Folk catch fire with "Shellfish Song". Andy Kim picks up U.S. gold for "Baby I Love You". Capitol bows Canadian pubbery Capitol Music CAPAC and Beechwood Music BMI. Columbia commands 50% U.S. trade action on classics. Allan Nicholl picked to play Claude in New York production of "Hair". Ottawa's Mythical Meadow gains chart action with Quality release "The Day Has Come". Released on Colossus in the U.S. Oliver into Toronto's Colonial Tavern. Electra's Doors making good sales for Allied Records. "Glen Campbell Live" established hit on day of release. Martin Onrot's Bill Cosby productions showing "sold out" sing across Canada. Quality bows their new Canadian budget line, "Birchmount". The series is 90% Canadian oriented. GRT making strong gains with their "Groovy Things" deck by Mafic Cycle on the Fingerprint label. The Eighth Day's lid "Hear The Grass Grow" on the GRT label also showing good national gains. Warner Bros/Reprise release "Easy Rider" soundtrack which scores instantly. 5th Dimension given red carpet treatment through courtesy of London Records on their appearances at Montreal's Man and His World as well as engagements throughout the Atlantic Provinces. French Canada experiencing disc sales problems. Although separatists are becoming much larger, vocally, they obviously aren't making an impression with record buying public. English disc sales and radio exposure are up while homegrown and across the sea French have fallen off.

September

September was the month that Revolution officially bowed the Canadian market. They are however, already creating an international name for themselves with the chart success of Motherlode "When I Die" and follow-up album. Mort Ross, Doug Riley and Terry Brown head up this successful operation. Polydor Records picks up two Moffat Awards. One for Best Folk or Country with the entry of the Five Bells "Moody Manitoba Morning". "Hands Of The Clock" by Life picked up Award for "Best Beat Record". Many broadcasters increasing Canadian content on own hook. CKYL now up to 28%. Mother Tucker's Yellow Duck release new album on Capitol. CFCN Calgary spotlights country artist Dick Damron in drive to promote more Canadian talent. Trini Lopez into Royal York's Imperial Room to open Moxie Whitney's twentieth year of supplying orchestral backing at the posh room. Michel Vincent released "The Lady In The Picture" from his latest Polydor album. Ray Hutchinson signs with Modern Tape Cartridge Corporation of Canada. RCA and Columbia enter cassette race. Murray Cherkover takes over helm of CTV network. Canadian Talent Library rush releases new Boss Brass LP #2. Bobby Curtola into Toronto's Town & Country Club and for the third consecutive time pulled capacity houses for his complete engagement. Creedence Clearwater awarded gold for "Bad Moon Rising". Ronnie Hawkins signs distrib deal with MTCC for Hawk label.

October

The month of October returned good sales to Columbia on their recent entry into the cassette market. Five Man Electrical Band's Capitol deck "Riverboat" given top pick on the MLS

System. The Poppy Family's "Which Way You Goin' Billy" makes it to the No. 1 position on Canadian charts. This London single is to be released in the U.S. Sugar Shoppe leave Capitol and bow their first single for Epic "Save The Country". "Je T'Aime—Moi Non Plus", the Fontana deck by Jane Birkin and Serge Gainsbourg has caught fire across Canada. All London offices report good sales returns and radio exposure. CKFH Toronto breaks disc for Metro area. James Last's Polydor album "Hair" causes sensation across Canada. Poppy Family sing exclusively with London Records. The Maple Leaf System begins to draw anger of industry by not fulfilling promises of extra exposure for Canadian releases. Polydor to distribute Flying Dutchman. Initial release is "Hair" by Tom Scott. Ampex of Canada introduces new MM-1000 series multi-channel recorder. RCA's Carlton Showband complete taping and hit road on tour with CTV's "Pig & Whistle". "One Tin Soldier" by Original Caste subject of giant promotion drive by Quality. The MLS picks "Undun" flip of current Guess Who happen "These Eyes". RCA's million dollar studios officially opened. Young and Company release their first for RCA, "Come Out Come Out". CKOC's Nevin Grant breaks Guess Who's "Undun" on CKOC Hamilton. Compo releases "Lightfoot Live". The session was taped at a recent Massey Hall concert. The Canadian Broadcasting Corporation kicks off its 3rd Annual Song Fest. Larry and Lynda team up to release their Nugget single "Most Peculiar Girl". Duff Roman takes on-air duties at CKFH Toronto. Von Zubans reopen their twice burnt out record bar in Sudbury. Their Melody Music Store has become one of the entertainment symbols of Northern Ontario. Quality releases the Paramount soundtrack of "Paint Your Wagon".

November

November is the Fiftieth anniversary of broadcasting in Canada. The MLS picks "One Tin Soldier" by Original Caste. George Taylor releases Jack Hardin's "I'm Not Running After You Anymore" on his Melbourne label. Tranquility Base sign with RCA. Studio 3 moves from California to form basis of Studio 3 Productions headed up by Ralph Harding, Jack Herschorn and Tom Northcott. Ginette Reno to have simultaneous UK release with her Canadian deck "Don't Let Me Be Misunderstood". This Montreal talent has already successfully broken into English Canada. The Marshmallow Soup Group, soon to release on RCA, have been selected to represent Canada at the International Trade Fair in Lima Peru. Michael Butler, financial genius behind "Hair" productions, into Toronto to set stage for Toronto's production. Polydor releases their early cuts of the Beatles entitled "The Beatles Very Together". Trans Canada Communications Ltd., which is comprised of radio stations CKCK Regina, CKRC Winnipeg and CKOC Hamilton have underwritten the cost of a new CTL album by Winnipeg's Metro-Gnomes. Prime Minister Pierre Trudeau is presented with a gold disc of "Radio Radio", the CAB/CAPAC's theme disc for their fiftieth anniversary. Montreal's Les Contretemps performed the song "live" for the Prime Minister. Big Chief Records, out of Lethbridge Alberta releases disc product by Shirley Ann, Angus Walker, and Eddie Brandle. Arc Records releases their "Diamond Lil" set. Don Grashey and Chuck Williams open their new DMG Sound Studios in the Lakehead. Capitol Records launches effort to promote domestic artists. First group to receive the Capitol push through Ontario promotion manager Joe Woodhouse is Mother Tucker's Yellow Duck. Edward Bear are next and The Dubliners and Peter Law follow. Columbia set to dis-

tribute Fillmore product. Martin Onrot presents Laura Nyro to packed Massey Hall. Columbia Records pulls all stops in the promotion of Johnny Cash product. BMI (Canada) sells pubbery to Berandol Music Ltd., the latter being headed up by Andrew Twa. George Taylore, prexy of Rodeo Records releases the Horsburgh story on disc to coincide with the release of the novel under title "From Pulpit To Prison". Doing the singing honours is The Singing Parson and his wife Sharon. An album is to follow. Gordon Pinsent releases on Arc. Dave and Irene Ralston's Lucarno Ballroom (Toronto) receive industry support in effort to beef up their Sunday concerts which features Canadian country artists. Jack London back on scene once again, (he was formerly with Sparrow, now Step-penwolf) with a new group called It's All Meat. They release "Feel It" on Columbia. Johnny Cash into Toronto's Maple Leaf Gardens for record breaking house. Doug Kershaw, Warner Bros recording star, steals some of the Cash thunder and hits hard with his new album and single "Diggy Diggy Lo". John Perrone, a member of the staff of the Royal Conservatory of Music, tapes session of guitar works for the Canadian Talent Library. Ginette Reno, Parrot recording star and promotion manager for London, Pierre Bellemare, strike west to promote new album. Donald Tarlton and his Donald K. Donald Productions takes over production activity for Montreal's Forum concerts. Edward Bear are off and running with their new album containing "You Me And Mexico", soon to be released as a single. London Records present plaques to industry figures who assisted in the boost of the Poppy Family's "Which Way You Goin' Billy". Frank Gould, one of the steady hands of the Maple Leaf System and music director of CFOX Montreal, exits this post for hoped for employment in the record business. Capitol's Band pull capacity house at Montreal's Place des Arts. Capitol opens new branch office in Montreal. RCA's two powerhouses for the month of November are: "Lightfoot Country" by George Hamilton IV and the new Light-house LP. Gerry Lacoursiere appointed Director of Canadian operation set to go it alone in April. Alan Katz joins Polydor Records to head up special markets division. Vancouver still leading country as entertainment centre. Warner Bros. promotion manager for west coast, Bruce Bissell, adding much to promotion activity of label's artists.

The Maple Leaf System still under heavy fire by critics for doing nothing about disks picked by System. Roland Legault appointed national advertising and sales promotion manager for Capitol Records (Canada) Ltd. Roy Hennessy of CKLG Vancouver takes over as new chairman of MLS replacing CHUM's J. Robert Wood. Action shifts to west coast and secrecy. Harold E. Shatz Jr. appointed director of advertising for Capitol Records (Canada) Ltd. The Guess Who cut a session at RCA's Chicago studios. Gordon Lightfoot moves from United Artists to Warner Bros. "Abbey Road" by the Beatles makes it to the No. 1 spot on the album charts. Elwood Glover celebrates 7th year as host of the CBC-TV's "Luncheon Date" now produced by Nigel Andrews. Gary Buck makes national gains with his Capitol deck "Wayward Woman Of The World". Compo bows "Pop Apex" label. Polydor's Life releases "Sweet Lovin'" as follow-up to their successful "Hands Of The Clock". Northward Hair now ready for rehearsal and have set target date as Dec 31 for pre-view and Jan 11 for opening.

December

December sees Allied Records release two early Stompin' Tom Connors' albums. This Canadian country

(Cont. on Page 92)



nor-brand music b.m.i.

forsite music c.a.p.a.c.

375 west mall street,  
etobicoke, toronto,  
ontario, canada  
phone (416) - 621-0213

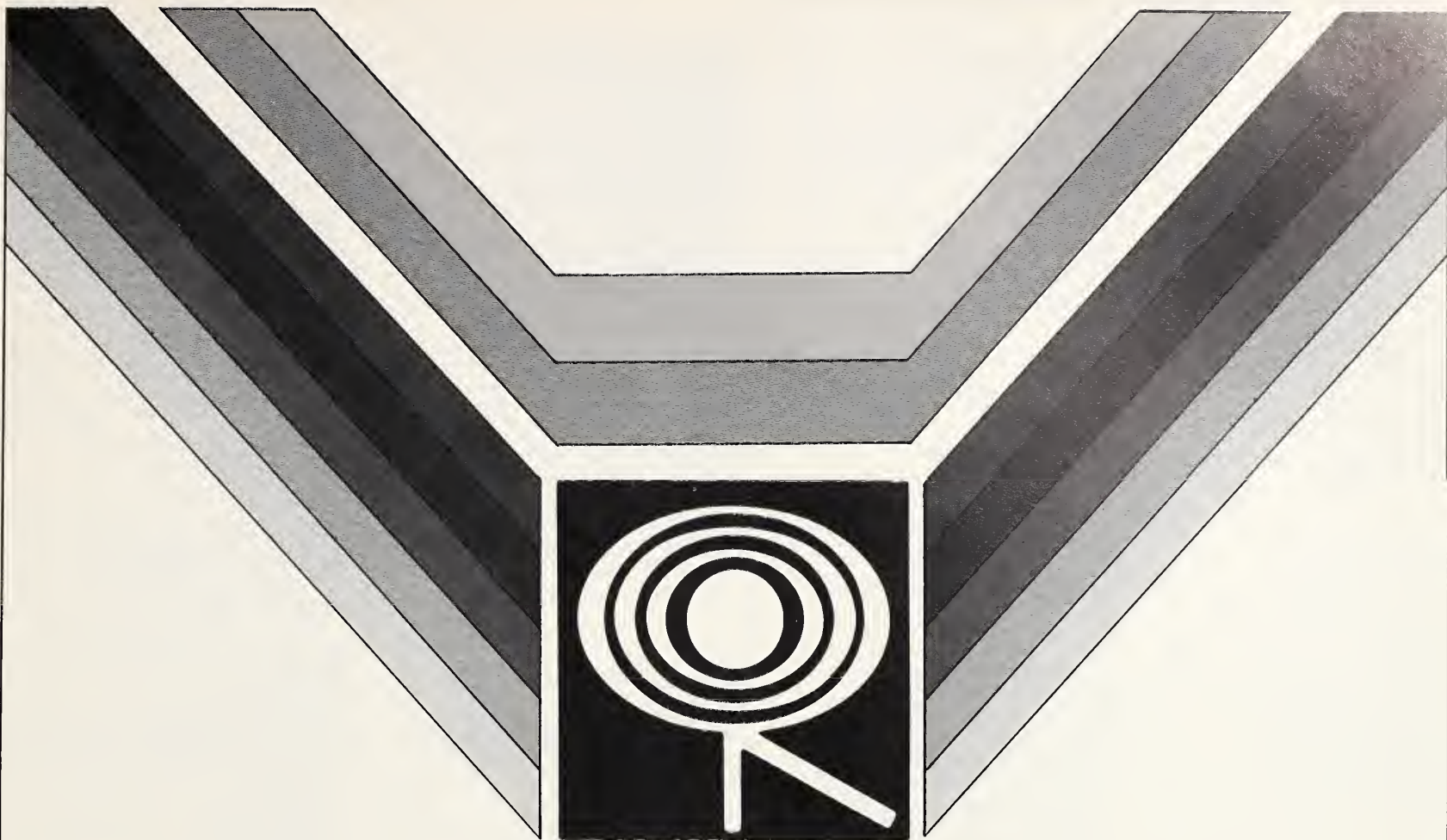

COLUMBIA RECORDS OF CANADA, LTD.  
COLUMBIA RECORDS DISTRIBUTORS CANADA, LTD.  
COLUMBIA RECORD CLUB  
APRIL MUSIC (CANADA) LTD.  
BLACKWOOD MUSIC (CANADA) LTD.  
CBS MUSICAL INSTRUMENTS (CANADA)  
Fender Musical Instruments  
Rogers Drums  
Rhodes Pianos  
MASTERWORK AUDIO PRODUCTS (CANADA)  
COLUMBIA SPECIAL PRODUCTS  
ALL RECORDS SUPPLY COMPANY OF CANADA LIMITED

**SOUND**

# Canada's Records Manufacturers

**A & M RECORDS OF CANADA LTD.**  
255 Yorkland Blvd. Willowdale, Ont.  
(416) 491-2525  
Managing Director: Gerry Lacoursiere  
Promo: David Brodeur (Montreal)  
Liam Mullan (Toronto)  
Labels: A&M - Ode  
DISTRIBUTED BY:  
Canadian Assemblies  
Station Rd. Amherst, Nova Scotia  
Capitol Records (Canada) Ltd.  
3109 American Dr. Malton, Ont.  
London Records of Canada (1967) Ltd.  
190 Graveline St. St. Laurent, P.Q.

**ALLIED RECORD CORPORATION**  
104 Doncaster Ave. Willowdale, Ont.  
(416) 889-8566  
Vice President: Jack Boswell  
Labels: Asch Broadside - Bang - Bel Canto - Checkmate - Conversa-Phone - Elektra - Marathon - None-such - Paragon - Recoton - Roulette - Time  
DISTRIBUTED BY:  
Allied Records  
3285 Dutch Village Rd. Halifax, N.S.  
190 Ronald Drive, Montreal, P.Q.  
Box 517, Willowdale, Ont.  
Allied Records - Winnipeg  
Allied Records - Vancouver

**AMPX OF CANADA LTD.**  
100 Skyway Ave. Rexdale, Ont.  
(416) 677-2370  
Vice President: James E. Detlor  
Nat'l Sales Manager: Joe Pariselli  
Nat'l Promotion: Joanne E. Messham  
Labels: Ampex - Lizard  
DISTRIBUTED BY:  
Western Agencies Ltd.  
971 Richmond St. W. Vancouver, B.C.  
Van Dusen Bros.  
10357 - 109th St. Edmonton, Alta  
Laurel Records  
1299 Strathcona St. Winnipeg, Man.  
Ampex Of Canada Ltd.  
100 Skyway Ave. Rexdale, Ont.  
London Records of Canada Ltd.  
190 Graveline St. St. Laurent, P.Q.  
Maritime Records  
188 1/2 Mountain Rd. Moncton, N.B.  
Atlas Hardware  
Cornerbrook, Nfld.

**ARC SOUND LIMITED**  
20 Cranfield Rd. Toronto 16, Ont.  
(416) 751-1613  
President: Phil G. Anderson  
Vice President: Bill Gilliland  
Labels: Arc - Arc Citation - Arc Centennial - Good-groove - Monique - Yorkville - Saga - International Artists - Somerset - Alshire - Happy House - Stereoditties - Family  
DISTRIBUTED BY:  
Arc Sound Ltd.  
322 Drake St. Vancouver 3, B.C.  
Central Records  
3631 Blackburn Rd. Calgary, Alta  
National Records  
358 Colony Rd. Winnipeg, Man.  
Arc Sound Ltd.  
20 Cranfield Rd. Toronto 16, Ont.  
GRT of Canada Ltd.  
8400 Cote de Liesse, St. Laurent, P.Q.  
Crawford-Atlantic  
42 Brandon St. Moncton, N.B.

**BRAVO RECORDS & MUSIC LTD.**  
58 Advance Rd. Toronto 570, Ont.  
(416) 537-3512  
President: Johnny Lombardi  
Labels: Bravo - Carisch - Carosello - PDU - Ricordi - Vis  
DISTRIBUTED BY:  
Emerson Sales Ltd.  
1859 W 4th St. Vancouver, B.C.  
Central Records  
3631 Blackburn Rd. Calgary, Alta  
Electrical Supplies  
312 William Ave. Winnipeg, Man.  
Canadian Music Sales Corp. Ltd.  
58 Advance Rd. Toronto 570, Ont.  
Trans Canada Records  
189 Rockland Rd. Montreal, P.Q.

**CANADIAN MUSIC SALES CORP LTD.**  
58 Advance Rd. Toronto 570, Ont.  
(416) 239-2361  
President: T. St. Clair Low  
Nat'l Sales Manager: Terry Regan  
Nat'l Promotion: Jury Krytiuk  
Labels: Dominion - Big Chief - Caribou (Don-Joe) - Transatlantic - Xtra - Classic Additions - Proscenium - Alto - All Nations - Voyageur - Stenodisc - 49th State - Sonologue - Beaver - Telco - Venus - Canary - Educo - Alfred - Glenside  
DISTRIBUTED BY:  
Emerson Sales Ltd.  
1859 W 4th St. Vancouver, B.C.  
Central Records  
3631 Blackburn Rd. Calgary, Alta  
Electrical Supplies  
312 William Ave. Winnipeg, Man.  
Canadian Music Sales Corp. Ltd.  
58 Advance Rd. Toronto 570, Ont.  
Trans Canada Records  
189 Rockland Rd. Montreal, P.Q.

**CANADIAN MUSIC SALES CORP LTD.**  
58 Advance Rd. Toronto 570, Ont.  
(416) 239-2361  
President: T. St. Clair Low  
Nat'l Sales Manager: Terry Regan  
Nat'l Promotion: Jury Krytiuk  
Labels: Dominion - Big Chief - Caribou (Don-Joe) - Transatlantic - Xtra - Classic Additions - Proscenium - Alto - All Nations - Voyageur - Stenodisc - 49th State - Sonologue - Beaver - Telco - Venus - Canary - Educo - Alfred - Glenside  
DISTRIBUTED BY:  
Emerson Sales Ltd.  
1859 W 4th St. Vancouver, B.C.  
Central Records  
3631 Blackburn Rd. Calgary, Alta  
Electrical Supplies  
312 William Ave. Winnipeg, Man.  
Canadian Music Sales Corp. Ltd.  
58 Advance Rd. Toronto 570, Ont.  
Trans Canada Records  
189 Rockland Rd. Montreal, P.Q.

**CAPITOL RECORDS (CANADA) LTD.**  
3109 American Drive, Malton, Ont.  
(416) 677-5050  
General Manager: Arnold Gosewich  
Nat'l Sales Manager: E. Taylor Campbell  
Nat'l Promotion: Hal Schatz  
Labels: Capitol - Saraphin - Apple - Harvest - Disney - Pickwick - A & M - Immediate - Invictus - Crazy Horse - 1-2-3 - Angel - Molodiy Angel - Muse - Pathe - Buena Vista - Odeon - Parlothon - Revolution - 20th Century Fox  
DISTRIBUTED BY:  
Capitol Records Distributors  
155 Port Royal W. Montreal 11, P.Q.  
3109 American Dr. Malton, Ont.  
1255 Grant Ave. #306, Winnipeg, Man.  
519 Manitou Rd. S.E. Calgary, Alta.  
3622 East 1st. Ave. Vancouver, B.C.

**CARAVAN RECORD SALES LTD.**  
117 Midwest Rd. Scarborough, Ont.  
(416) 757-2455  
President: Frank P. Swain  
Nat'l Sales Manager: John Loweth  
Labels: V Records - UK Records - Edmar - Caravan - Fiesta - Grecophone - Ital Recording Artists - Merry-disc - Duane - Waico Needles & Accessories  
DISTRIBUTED BY:  
Emerson Sales Ltd.  
1959 W 4th St. Vancouver, B.C.  
Van Dusen Bros.  
10357 - 109th St. Edmonton Alta.  
K Records Ltd.  
15 Fleury St. Winnipeg, Man.  
Caravan Record Sales Ltd.  
117 Midwest Rd. Scarborough, Ont.  
Polydor Records Canada Ltd.  
4115 Sherbrooke West Montreal, P.Q.

**COLUMBIA RECORDS OF CANADA LTD.**  
1121 Leslie St. Don Mills, Ont.  
(416) 447-3321  
Managing Director: Fred T. Wilmot  
Nat'l Sales Manager: Jack Robertson  
Nat'l Promotion: William Eaton  
Labels: CBS - Columbia - Date - Epic - Harmony - Harmonie - Major Minor - Ode - Odyssey - Okeh - Rojac - Starday  
DISTRIBUTED BY:  
Columbia Record Distributors Canada Ltd.  
1168 Montee de Liesse, Montreal, P.Q.  
1112 Leslie St. Don Mills, Ont.  
4624 Manitoba Rd. Calgary 24, Alta  
116 S. E. Marine Dr. Vancouver 15, B.C.

**THE COMPO COMPANY**  
2377 Remembrance St., Lachine, P.Q.  
(514) 637-2561  
MCA Building 2450 Victoria Park Ave.  
Willowdale, 425 Ont. (416) 491-3000  
General Manager: R. A. Chislett  
Nat'l Sales Manager: S.D. Roberts  
Manager - Apex Division: Lee Armstrong  
Field Promotion Manager: Allan Matthews  
Labels: Decca - Coral - Brunswick - MTA - UNI - Kapp - Congress - Revue - Abnak - Accent - Apex - B.T. - Puppy - Carnival - Cycle 2000 - Event - Four Corners - GNP - Crescendo - Lero - Point - Pop Apex - Revolver - Scepter - Shamley - Solid State - Straight - Sundown - United Artists - Wand - Musicor - White Whale  
DISTRIBUTED BY:  
Apex Records Ltd. (MCA Building)  
2450 Victoria Park Ave. Willowdale, Ont  
Waldale Limited  
P.O. Box 339, Amherst, N.S.  
Thomas Rathwell Limited  
575 Roseberry St. St. James, Winnipeg, Man  
Acklands Limited (Record Division)  
2918 - 11th. S.E. Calgary, Alta.  
Johnston Appliances Limited  
5239 Victoria Dr. Vancouver, B.C.

**GRT OF CANADA LTD.**  
1045 Hargrrieve Rd. London, Ont.  
(419) 434-4534  
Direct from Toronto 364-5039  
President: Ross B. Reynolds  
Nat'l Sales Manager: Edward P. LaBuick  
Nat'l Promotion: Edward J. Lawson  
Labels: Chess - Checker - Head - Cadet - Concept - De-Lite - GRT - Hi-Fi - Sound - Janus - Hobbit - Westbound - Tamarac  
DISTRIBUTED BY:  
Emerson Sales Ltd.  
1859 W 4th St. Vancouver, B.C.  
Van Dusen Brothers Ltd.  
10357 - 109 St. Edmonton, Alta  
A.A. Murphy & Sons  
2120 St. George St. Saskatoon, Sask  
Laurel Record Distributors  
1299 Strathcona St. Winnipeg, Man.  
GRT Of Canada Ltd.  
175 Midwest Rd. Scarborough, Ont.  
GRT Of Canada Ltd.  
175 Midwest Rd. Scarborough, Ont.  
GRT Of Canada Ltd.  
8400 Cote de Liesse, Montreal, P.Q.  
Canadian Assemblies Ltd.  
Amherst, Nova Scotia

**LONDON RECORDS OF CANADA LTD.**  
190 Graveline St. St. Laurent, P.Q.  
(514) 735-5551  
President: Fraser Jamieson  
Product Administrator: Alice Koury  
Nat'l Sales Manager: Adrian Bloudeau  
Manager Liberty Group: Dave Doucette  
London - Phase 4 - Deram - Hi - Sire - Coliseum - Ace of Clubs - Parrot - Emerald - Global Heritage - Amos - ESP Disk - Athena - Ameret - Jamie - Evolution - Galaxy - Gamma - LHI - Kilmarnock - Mainstream - Melbourne - Mobile Fidelity - Monument - Page One - Rodeo - Sound Stage 7 - Yew - Celtic - Melody - Aragon - Major Banfi - Golden - Liberty - Dolton - Imperial - Minit - Soul City - Smash - Bluenote - World Pacific Jazz - Philips - Living Presence - Blue-rock - Fontana - Intrepid - Limelight - Mercury Wing - Childcraft - Story Teller - 6th Avenue - Franklin - Coast - Ashley - Wayside - Bamboo - Sue - Duke - President - Backbeat - Multicolor - Red - Sonic - Canetti - Neptune - Disc-o-pol - Yoga - Sex Disques - Fleche - Carrere - Pergola - Aquarius - Select - Grande Prix - Disco Bel Air - Jupiter - Gamma - La Compagnie - Marc - Caprice - Lion - Initiation - Le Patriote - Bagatelle - Musidisc - Argo - Ace Of Diamonds - Richmond - Cynus - L'oiseau lyre - Telefunken - Das Alte - Werk - Society Francaise Du Son - Philips World Series  
DISTRIBUTED BY:  
London Record Distributors Ltd.  
3166 Lake City Way, Burnaby 2, B. C.  
628 11 Ave. S.W. Calgary, Alta  
23 Keith Rd. Winnipeg 2, Man.  
1630 Midland Ave. Scarborough, Ont.  
180 Graveline St. St. Laurent, P.Q.

**MODERN TAPE CARTRIDGE CORP LTD.**  
1179 Finch Ave. Downsview, Ont.  
(416) 630-8494  
President: Gary Salter  
Vice President: Robert Martin  
Nat'l Sales Manager: Harry Gottlieb  
Nat'l Promotion: John Driscoll  
Labels: Hawk - MTCC - ITCO - Firebird - Tonsil  
DISTRIBUTED BY:  
MTCC (Modern Tape Cartridge)  
1179 Finch Ave. W. Downsview, Ont.  
Van Dusen Bros Ltd.  
10528 123rd St. Edmonton, Alta.  
Alamada Corporation  
380 Craig St. W. Montreal, P.Q.  
Select Music Co.  
133 West 5th Ave. Vancouver 10, B.C.  
Thomas Rathwell  
575 Roseberry St. St. James, Manitoba  
Maritime Records Ltd.  
188 1/2 Mountain Rd. Moncton, N.B.

**MUSIMART LTD.**  
970 McEachran Ave. Montreal 154, P.Q.  
(514) 273-8354  
President: George E. Erlick  
Nat'l Sales Manager: Jack Inhaber  
Nat'l Promotion: Michel Cordy  
Labels: Abbey - Ambassador - Apon - Apple Honey - Cabot - Candide - Cathedral - Colosseum - Dacama - Diplomat - Pierrot - Dooto - Dyer Benet - Electocord - Elite - ESP - Eurotone - Fantasy - Folklore - Galaxy - Gateway - Guest Star - Haloyon - Let's Sing - Lyrichord - MIO - Mandolino - Mountain Dew - Monmouth Evergreen - Panoramia  
DISTRIBUTED BY:  
Musimart Ltd.  
970 McEachran Ave. Montreal 154, P.Q.

**PHONODISC LTD.**  
30 Malley Rd. Scarborough, Ont.  
(416) 751-9610  
President: Donald McKim  
Nat'l Promotion: Miss Toni Yamane  
Labels: Ariston - Audio Fidelity - Chart - Commonwealth Union - GWP - Hickory - Jubilee - Metro-media - Paula - Pye - Tamla Motown - Vanguard - VMC  
DISTRIBUTED BY:  
Phonodisc Ltd.  
809 William St. Montreal, P.Q.  
30 Malley Rd. Scarborough, Ont.  
1117 Sanford St. Winnipeg, Man.  
4235 East Hastings St. Burnaby, B.C.  
Central Record Co.  
4511 Manitoba Rd. S.E. Calgary, Alta.

**POLYDOR RECORDS CANADA LTD.**  
4115 Sherbrooke St. W. Montreal 215, P.Q.  
(514) 933-4201  
Managing Director: Fred Exon  
Nat'l Sales Manager: Frank Henry  
Nat'l Promotion: Allan Katz  
Director Artist Promotion: Lori Bruner  
Labels: Polydor - Deutsche Grammophon - ABC - Archiv - Ariola - Avant Garde - Bluesway - Blue Thumb - Command - Grand Award - Heliodor - Impulse - Marmalade - Music Guild - Music Royale - Privilege - Probe - Riverside - Simon Says - Westminster  
DISTRIBUTED BY:  
Polydor Record Distributors  
5000 Buchan St. Montreal, P.Q.  
3279 Lenworth Dr. Cooksville, Ont.  
196 Smith St. Vancouver, B.C.

**QUALITY RECORDS LIMITED**  
380 Birchmount Road, Scarborough, Ont.  
(416) 698-5511  
Managing Director: George L. Keane  
Nat'l Sales Manager: Lee W. Farley  
Nat'l Promotion: Harold Winslow  
Labels: Bell - Buddha - Casl - Curton - Crewe - Dot - Enterprise - Heritage - Kama Sutra - Laurie - Mave-rick - MGM - Palette - Paramount - Pavillion - Plarstia-tion - Ranwood - SSS Int'l - Sound Foundation - Smobros - Sun - Stax - Steed - T-Neck - Together - United Talent - Verve-Forecast - Volt - Windfall - Birchmount  
DISTRIBUTED BY:  
Taylor, Pearson & Carson Ltd.  
2182 W 12 Ave. Vancouver 9, B.C.  
Taylor, Pearson & Carson Ltd.  
Box 7000, Calgary, Alta  
Canadian Assemblies Ltd.  
Amherst, Nova Scotia  
Quality Records Limited  
4th Floor, Galt Bldg, Winnipeg, Man.  
130 Mack Ave. Scarborough, Ont.  
2215 Beaconsfield Ave., Montreal, P.Q.

**RCA LIMITED**  
3333 Cavendish Blvd. Montreal 28, P.Q.  
(514) 482-9912  
Vice President: George I. Harrison  
Nat'l Sales Manager: Andy Nagy  
Labels: Avco-Embassy - Dunhill - Happy Tiger - Jad - Poppy - Nimbus 9 - RCA - RCA Camden - Colgems - Calendar - Bravo - Earth - Equinox - Julmar - Bra - Kerr - Life - Traffic - Gala  
DISTRIBUTED BY:  
RCA Ltd.  
2876 Rupert St. Vancouver, B.C.  
Box 5158 Stn A, Calgary, Alta.  
1450 Castlefield Ave. Toronto 15  
3333 Cavendish Blvd. Montreal 28

**RODEO RECORDS LIMITED**  
215 Victoria St. Toronto 205, Ont.  
(416) 368-3362  
President: George Taylor  
A&R Director: Dougal Trineer  
Labels: Banff - Celtic - Caprice - Melbourne - Rodeo International  
DISTRIBUTED BY:  
London Records Of Canada Ltd.

**TRANS WORLD RECORD CO INC.**  
1180 St. Antoine St. Montreal, P.Q.  
(514) 866-2884  
President: Art Young  
Nat'l Promotion: Ray Johnston  
Labels: Amusement - Artia - Boite A - Musique - Bon Bon - Bouffon - Caedmon - Dictation Disc - Disques AZ - Douglas - Edmar - Ember Disc - Disc Carrere - Fiesta - Folkway - Grecophon - Les Disc Voix De L'Auteur - Les Disques Spectrum - Murray Love - Major Minor - DSP - Montagnard - Murray Banks - Panda - Pak - Parliament - Project 3 - Recital Hall - Spoken Art - Skye - Trans World - Urania - Wonderland - UFP - Young Blood  
DISTRIBUTED BY:  
Trans World Records  
1230 Montee De Liesse, Montreal, P.Q.  
117 Midwest Rd. Scarboro, Ont.  
Van Dusen Bros.  
738 11th Ave. S.W. Calgary, Alta.  
10147 112 St. Edmonton, Alta.  
Emerson Sales  
1850 West 4th Ave. Vancouver B.C.

**WARNER BROS RECORDS CANADA LTD.**  
220 Brunswick Blvd. Pointe Claire, P.Q.  
(514) 697-7440  
General Manager: Ken Middleton  
National Sales Manager: Gordon Edwards  
Director Marketing: Mike Doyle  
Labels: Atco - Atlantic - Cotillion - Disque Vogue - Embryo - Reprise - Warner Bros.  
DISTRIBUTED BY:  
Warner Bros. Distributors  
40 East 5th Ave. Vancouver 10, B.C.  
4640 Manhattan Rd. Calgary, Alta.  
24 Stevens Rd. St. James, Winnipeg, Man.  
4480 Chesswood Dr. Downsview, Ont.  
220 Brunswick Blvd. Pointe Claire, P.Q.  
Avalake Distributors  
Station St. Amherst, Nova Scotia

**WORLD RECORDS (Shotgun-Gimme Ltd.)**  
484 Waterloo St. Oshawa, Ont.  
(416) 576-0250  
President: Tom Reid  
Vice-President: William Hewson  
Product Co-ordinator: Bob Stone  
Labels: World - Scope - Cascade - C.T.L. - Sound Canada - Hi-Lite - P.I.P. - Fax - Pickwick Classics and Tape - Almada Group (Ontario only).  
DISTRIBUTED BY:  
Select Music  
2010 Alberta St. Vancouver, B.C.  
Van Dusen Bros  
Calgary & Edmonton  
K. Records Ltd.  
15 Fleury Place, Winnipeg, Man.  
World Records  
484 Waterloo St. Oshawa, Ont.  
Almada Corp.  
380 Craig St. W. Montreal, P.Q.

## Canada - Past 12 Mos.

(Con't. from Page 90)

giant is already making good chart gains with "Bud The Spud" on the Dominion label. John Lennon and his mate, Yoko, pay visit to Toronto and sack out at the Ronnie Hawkins' farm just north of Toronto. London Records releases the Poppy Family's album "Which Way You Goin' Billy" featuring Susan Jacks. MTCC set to distribute Firebird product in Canada. Juliette's "Country World" on RCA's Camden series breaks nationally. Decca's "Superstar" by Murray Head is released in Canada. Compo's field promotion manager publishes kudos from Canadian churchmen on pseudo-religious disc. MTCC releases Ronnie Hawkins' Hawk single "Little Bird". Peter Paul and Mary top charts with "Leaving On A Jet Plane". All disc reports 50% increase in one stop business over past year. Much of increase due to tape product although disc product sales have also advanced. Big Chief's Merv Smith breaks into country charts with "The Way You Play". Webcor moves to larger quarters. Increased business makes move necessary and addition of several new hands. CHUM's bid to buy Montreal's CKGM denied by CRTC. RCA's Ontario branch under manager Ed Preston shows excellent gains over previous December period. Tommy Roe with "Dizzy" on ABC and Blind Faith's new album certify for Canadian gold. Certification made by Polydor's managing director Fred Exon.

## January

The new year sees several RCA groups making good chart gains including Marshmallow Soup Group with "I Love Candy" and Young and Company with "Come Out, Come Out". Allan Nichols, star of the New York production "Hair" bows his new release from Avco Embassy entitled "Going Down". McKenna Mendelson Mainline split after showing favourable chart gains with their Liberty album. The Chapparals' first album for Capitol gains with country buyers. Frank Moore releases "Winter Days" on the Hawk label. Calgary's Happy Feeling break out with their Barry

(Con't. on Page 93)



# Canada—The Past 12 Months

(Con't. from Preceding Page)

deck "Good Neighbour Day". Grant Fitzpatrick and Brian Pombiere signed as exclusive independent producers for Arc Sound. Releases will bow on the Family label. First set for release is by Nucleus. Jim McHarg appointed promotion director for the AHED group, which is controlled by Arc Sound. Allan Sisters stir up Bermuda with their Island tour. The Merrymen bow "La Belle Citie" and "My Love For You". Both sides register hit status for Caravan Records. Terry David Mulligan, one of Canada's top free form radio personalities moves into CKFH and the "Open Lid" show. Dave Hamel of Langley British Columbia, releases album "Please Remember" on the Aragon label. Anthony Green and Barry Stagg release first English disc for the powerful French Canadian Gamma label.

## February

February sees Capitol's Edward Bear flexing muscles for chart action with their "You Me And Mexico" deck. CHUM enters record business and calls record exec meet to hear first production by Toronto's Tote Family. The release is picked up by Arc Sound. Ampex enters disc field with release of five albums, The Great Speckled Bird with Ian and Sylvia, Jamul, The American Dream, Jesse James, and Gil Evans. Harold Smith record pioneer and former head of Capitol Records (Canada) Ltd. dies at 71. Vancouver's Collectors sign with London Records. Canadian Music Sales pacts with Tribune. "Down In The Alley" now established as national hit for Ronnie Hawkins on his own Hawk label. Melbourne releases their first spoken word album with the "John Drainie read Stephen Leacock" album. Motherlode's Revolver deck "And When I Die" certifies for U. S. gold. Warner Bros Seven Arts changes its corporate name to Warner Brothers Records. Tape sales on increase with prophets predicting 35% by 1970. Andy Kim bows "A Friend In The

City" on Steed. Rich Little moves into the Royal York's Imperial Room. Vancouver's Collectors chalk up good sales with their new album for London which features their single "I Must Have Been Blind". Quality bows their new Celebration Publication, a weekly newsletter for retailers and press and radio. A&M opens Toronto offices with Gerry Lacoursier at helm. Columbia gets tough with retailers on Bob Dylan bootleg discs. Capitol (Canada) appoints Mac Manus John & Adams as their new advertising agency. Industry Award Winners include Andy Kim, top male singer; Ginette Reno, top female vocalist; Guess Who top vocal instrumental group; Gordon Lightfoot top folk singer; Tommy Hunter top country singer male, Diane Leigh, top country singer female, Mercey Brothers, top country group, Poppy Family's "Which Way You Goin' Billy" best produced single also best produced MOR album; Quality voted top Canadian content company; Capitol top promotion company, RCA top record company and CKLG Vancouver honoured for community activities and Saul Holiff as Canadian music industry man of the year.

## March

March sees Caravan's Terry Roberts make good gains on country charts with his deck "Don't It Make You Wanna Go Home". Warner Bros holds first convention with added Atlantic line holding much attention. Pierre Juneau's proposals of 30% Canadian content for Canadian programmers meeting with much fireworks across Canada. He leaves door open for further discussions. Acquarius Records bows in Montreal with Donald Talton heading the new label. Frank Gould takes over as label chief of U. S. product for Polydor Records. RCA holds meet at Montreal's Chateau Champlain. Musicor to be distributed by Compo. Irish Rovers bow Decca deck "Rhymes and Reasons". Manta Sound Productions bows puberty. Liam Mullan appointed promotion

coordinator for A&M Records and will work with Capitol Records in territory of Ontario west to British Columbia. David Brodeur takes over similar duties but will be headquartered in Montreal to work with London who will distribute A&M product throughout Ontario's eastern townships and the province of Quebec. Canadian Assemblies will look after Atlantic Provinces for label. Capitol bows Brian Browne set "The Letter". Capitol Inc. signs Catharine McKinnon. RCA launches Tranquillity Base deck "If You're Lookin'". "Tennessee Bird Walk" by Jack Blanchard and Misty Morgan, broken by CKWS personality Jim Wright. GRT to distribute Arc product in Quebec Province. Gainsborough Gallery release Reo lid "Ev'ry Man Hears Different Music". GRT's new Montreal branch headed up by Jim Corbett. CFRB and CKFH make gains in BBM survey.

## April

With spring just around the corner several announcements of proposed Peace Festivals have been made. John Brower plans a large fest at Mosport but after several weeks of negotiating has to look for another location. MTCC flies jocks in from across country for Ronnie Hawkins bash. GRT holds giant press party to open new Montreal offices. Donn Petrak's "Turn Me Around" published by Banff Music, selected as feature in movie "King", a documentary about the life of Martin Luther King Jr. Odetta to sing Petrak song. David Marsden appointed PD at Montreal's CKGM. Richard Glanville Brown appointed national artist promotion manager, for Capitol Records Bobby Curtola signs with Capitol Records. Roderick MacLeod appointed vice president All Records. Warner Bros set to release "woodstock" soundtrack. Don Aikens bows new Vancouver label, Pacific Star Records. Polydor declares April as "James Last Month". European giant flies into Montreal and Toronto to beef up promotion. George Wilson, Canada's top commercial voice joins CFRB and

takes over as host of "Starlight Serenade". Halifax group, Pepper Tree, tape for Capitol. Montreal's Sebastian finds favour with U. S. Decca after several months of release in Canada. Fraser Jamieson, president of London Records of Canada and Alice Koury, product administrator apply for certification of Canadian gold for Tom Jones, 7 awards; Engelbert Humperdinck, 5 awards, and one each for The Rolling Stones and 5th Dimension. Decca screens "Airport" at Toronto's Science Centre.

## May

May sees CFRB applying for purchase of CHML Hamilton. Johnny Cash has been signed for an appearance at Toronto's Fair. Cliff Jones bows his first for the Canadian Talent Library. Columbia bows Mashmakhan group. Canadian content picking up on stations across Canada. Quality launches David Jensen deck "You're My Life". London releases Michael Scholl lid "I've Forgotten" produced by Winnipeg TV personality Bob Burns, who also groomed the Guess Who in the early days. CKFH suffers setback with several on-air and production staff exiting. Capitol launches their "Sounds Canadian" promotion. Marketing director E. Taylor Campbell hits road with promotion. A&M's sampler "Cream of Cream" chalks up good sales across Canada. Compo Company releases Chimo on Revolver with their deck "Quicksilver Woman". Caravan and Polydor sign pact to distribute Merrymen product in Quebec. Aragon's Alan Moberg finds good market for his Aragon release "Walk In His Moccasins". Gordon Edwards upped to National Sales manager for Warner Bros. Arnold Palmer moves 10,000 units of "The Rangers Waltz" by Mom and Dads. Canadian Talent Library and World Records pact for distribution of new CTL label. CFRB's George Wilson breaks Ivan Rebroff product on his CFRB "Starlight Serenade" show. RCA bows Billy Charne's "To-Ma-Ray" deck. Warner Bros unveils new 8 track and cassette packaging. BMI holds Annual Certificate of Honour

(Con't. on next page)

## When you think of CANADA . . . think of . . .

 **Quality RECORDS LIMITED**

leading manufacturer and distributor of phonograph records and prerecorded stereo tapes

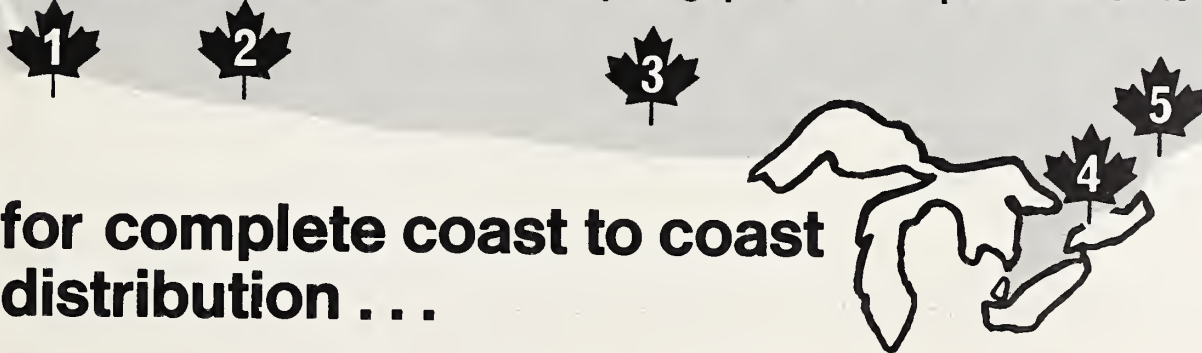

## for complete coast to coast distribution . . .

CONTACT: George L. Keane or George R. Struth — Phone 698-5511

Quality Records Limited, 380 Birchmount Road, Scarboro 704, Ontario.

U.S.A. OFFICE: Paul Marshall — Phone JU. 2-1122

130 West 57th Street, New York, NY 10019 c/o Marshall & Morris

### Branches and distributors in each of the major Canadian markets

 Reg Ayres — Taylor, Pearson & Carson (B.C.)  
1505 Venables Street, Vancouver, B.C.

 Jack Vermeer — Quality Records Limited  
Ontario Sales Division, 130 Mack Avenue, Scarboro 704, Ontario.

 John Watson — Taylor, Pearson & Carson (Alta.)  
Record Division, P.O. Box 7000, Calgary, Alberta.

 Gilbert Gendron — Quality Records Limited  
Quebec Sales Division, 2215 Beaconsfield Ave., Rm. 4, Montreal 261, Quebec.

 Chuck Porter — Quality Records Limited  
Mid-West Sales Division, 4th Floor Galt Bldg., Winnipeg, Manitoba.

 Bill Daley — Canadian Assemblies Limited  
Station Street, Amherst, Nova Scotia.

## The Record Ban:

At this time each year it is generally encouraging to report the continued steady growth of the recording industry Down Under; this year however the entire Aussie scene is hidden under a dark cloud, called for want of a better word; The Record Ban. No one thought it would actually come to pass; not one that is, except those executives at the very head of the dispute. But what has come to pass is the record industry's "blackest year". The disastrous state of affairs as it now stands, means that none of the one hundred and fourteen commercial radio stations in this country playing records originating out of English or European countries. Worse still, only a handful of local Australian records are being aired.

Each and every one of the stations aligned with the Commercial Federation of Broadcasting Stations (FACB) are involved, and are programming only American-originated discs. The nation-wide network of government-owned stations operated by the Australian Broadcasting Commission are not affected by the ban because they already pay an annual fee to the record companies for performance rights. (Also exempt from the present dispute are television stations and juke box operators.)

The broadcasters (FACB) are holding their ground, refusing to pay; and indications are that they will not relent.

Since the dispute came into effect a month ago, the Federation has supplied master lists of records (mainly American) to the stations, which are regarded as "safe" to play on air. We use the term "safe", because it is only American records which do not constitute an infringement of a new Copyright Act passed last year by Federal Parliament giving the record companies the right to seek a fee of up to a maximum of 1% of the total revenue earned by broadcasting stations. Cash

Box understands that the manufacturers (ARMA) are asking for only 1/2%, which would amount to somewhere in the vicinity of \$370,000 (Australian) per year.

Aussie stations look as though they will be sporting the "All American Sound" for some time to come. The broadcasters stress that the record companies forced them into dropping the records in question because of an unjust levy. (The radio industry already pays an amount close to \$740,000 to the Australian Performing Rights Association (APRA), but this is for direct payment of composer's royalties.)

Broadcasters believe that they provide invaluable publicity for the record industry, claiming that proof of this is the fact that sales of English and local Australian discs are now in rapid decline. Key commercial broadcasters in capital cities across the nation have suspended printing and publication of their hit charts which have been an important part of the scene here for some years, to say nothing of the good-will they have provided for individual stations.

The far-reaching effects of this dispute cannot be stressed too strongly, and the side-issues affecting record manufacturers are as important as they are numerous.

High on the list must surely be the big drop in over the counter sales . . . few people buy records they've never heard before. Most English/European records issued here by the major distributors enjoyed a large share of popularity in air-play and sales until last month; now they look like taking the biggest knock of all. English artists who realise the potential of the market here are up in arms because most of them, being as they are on long-term overseas contracts, are powerless to switch to an independent company.

Few people in this country dispute the fact that radio exposure is impera-

## ASTOR ELECTRONICS PTY. LTD.

1090-1140 Centre Road  
Clayton Victoria 3168  
Phone: 5442444  
Manager Record Division, Mr. Neville Smith  
Cables: Schur, Melbourne  
Labels: Astor, Vanguard, Amaret, Audio-Fidelity, None-such, Karate, Hi-Fi, Elektra, Century 21, Bravo; all MCA labels  
Distributors of Pye (England), Hanna-Barbera, Tradition, MTA, Crown; Budget-Sound

## AUSTRALIAN RECORD COMPANY LIMITED

11-19 Hargrave Street,  
East Sydney,  
New South Wales. 2010  
Phone: 314111  
Managing Director, Mr. A.W.T. Smith  
Cables: Colerecord, Sydney  
Labels: CBS, Reprise, Warner Brothers, Kapp, Hickory, Epic, Chess, Harmony

## E.M.I. (AUSTRALIA) LTD.

301 Castlereagh Street,  
Sydney  
New South Wales 2000  
Phone: 20912  
Manager, Record Division, Mr. Cec Barlow  
Cables: Emiron, Sydney  
Labels: HMV, Columbia, Capitol, Decca (England), Parlophone, London, Vocalion, Disneyland, Stateside, Buena Vista, Tamla-Motown, Regal, Deram, Immediate, Viking, Encore, Angel, Ace Of Clubs, Ace Of Diamonds, Roulette, Dunhill  
Distributors of many overseas labels in Australia

## DELRON RECORDS PTY. LTD.

10-14 West Parade,  
West Ryde  
New South Wales. 2114  
Phone: 803193  
President, Mr. Brian Flaherty  
Cables: Delron, Sydney  
Labels: Delron, Vee Jay, Casino, Dewdrop

tive for a record's success on the popularity-sales charts, and the "familiarity" patter where the top hits are played every hour or so is the current policy on most Australian air outlets.

Australian artists affected by the dispute are even more aware of its consequences than their European counter-parts. Top stars like **Johnny Farhnam, Normie Rowe and Ronnie Burns** realise only too well the disastrous effects the ban is having on their careers.

Most of them work regularly on television shows, but all agree that it's the consent radio exposure that keeps them in demand. (Ex-Seekers girl **Judith Durham** for example, sings with A&M Records in the States so she is un-affected by the ban.) With their careers hanging in the balance, several top names have felt strongly enough about the present state of affairs to contact the Federal Attorney-General, requesting him to intervene on their behalf.

Many top disk names have told **Cash Box** that they have not been officially informed by the record companies to which they're contracted.

Understandably they're hopping mad and plans are under way to hold a nation-wide meeting of recording artists to voice an official protest and to decide a further course of action.

So now the diskeries have to face the fact that most of their big star names are planning to part company with them as soon as their contracts expire. Some artists, not on watertight agreements have already left to join the handful of independent labels that have sprung up.

It is these independents who are really coming into their own; they're not involved in the dispute simply because they are not demanding royalties. One such independent has no less than eight singles represented on the best seller lists. The loss of revenue from locally-produced records is not the only worry facing the big disc companies. They are even more concerned about the independents ever-increasing practise of using their newly-signed talent to record big hits from America and Europe. The indies get hold of a fast flying hit from America and record their own version with-in a few days, thereby short-circuiting the major distributors who hold the rights to the original master. This so-called practise of "cover versions" was all the rage here fifteen years ago when the top forty format first came into being, but the cover versions now being produced in Australia are not just cheap imitations; they are very often top-class works in their own right.

Contributing to the success of the cover version is the copyright regulation that forbids any broadcaster to

## FESTIVAL RECORDS PTY. LTD.

63-79 Miller Street,  
Pyrmont  
New South Wales. 2009  
Phone: 684021  
Managing Director, Mr. Frederick Marks  
Cables: Festival, Sydney  
Labels: Festival, 20th Century Fox, A&M, United Artists, Liberty, Imperial, World Pacific, Dolton, Sunset, Pacific-Jazz, Scepter, Atlantic, Dot, Paramount, Metro-media, Vogue (France), Monument, Clarion, A.T.A.; Leodon, Spin, Sunshine, Calendar, Project 3, Stax, Mr. G, LHI, Crescendo, Ranwood, MCA  
Distributors of King (Japan) King (USA) Stereo-Dimension, Plantation, and many overseas independent labels

## MINSTREL RECORDS CO. PTY. LTD.

467 Parramatta Road  
Leichardt  
New South Wales 2040  
Phone: 564283  
Manager: Mr. Tony D'Ambram  
Cables: Minstrel, Sydney  
Labels: Minstrel, Durium; also importers of many continental records

## PHONOGRAM RECORDINGS PTY. LTD.

200 Goulburn Street  
Sydney  
New South Wales 2000  
Phone: 2111577  
General Manager: Mr. Paul M. Turner  
Cables: Phonorec, Sydney  
Labels: Phillips, Polydor, Fontana, Mercury, Riverside, Wing, Zodiac, MGM, Verve, Buddha, Limelight, Smash, Deutsche Grammophon, Archiv, Heliodor, Caedmon, Kama-Sutra; Fable

## PHONO-VOX OF AUSTRALIA PTY. LTD.

155 Sydney Road  
Brunswick  
Victoria 3056  
Manager: Mr. Tony Tromeros  
Cables: Phonovox, Melbourne  
Labels distributed: Phono-Vox, Pop, Mode, Pacific, Marfer, Az Disc, Style, Phonocolour, Italdisc, Ducale, Sonet, Deutsche Vogue

## RCA LIMITED

11 Khartoum Road  
North Ryde  
New South Wales 2113  
Phone: 885444  
General Manager, Record division: Mr. Bill Walsh  
Cables: Radiointer, Sydney  
Labels: RCA, Vik, RCA Victrola, RCA Camden, Dumonde

## W&G RECORD PROCESSING CO. PTY. LTD.

185-187 A'Beckett Street  
Melbourne  
Victoria 3000  
Phone: 3297255  
Managing Director, Mr. Ron Gillespie  
Cables: Dualscale, Melbourne  
Labels: W&G, Diaphon, In, Gem, Word, Swaggle, W&G International

## Canada - The Past 12 Mos.

(Con't. from Page 94)

dinner at the Royal York Hotel (May 8). After CFRB's George Wilson aired the Miguel Rios A&M lid "A Song Of Joy", the label experienced sales action amounting to 35,000 copies shipped. Several other Toronto stations have also given good exposure to the disc. Ken Middleton appointed new head of the Canadian Record Manufacturers Association. Middleton is general manager of Warner Bros Canada. Barry Keane, A&R Quality Records, steps up production activity. Melbourne to release Rainville product. Mike Graham scores with his new Rodeo single "No Pity For A Fool". Compo signs pact to distribute Revolution product. Initial releases include "Moe's Curried Soul" by Moe Koffman and "Some Other Kind Of Soul" by Dianne Brooks. Ampex celebrates two years in Canada with their Ampex Stereo Tapes. CRTC Commissioner Pierre Juneau makes the 30% Canadian content final law. Columbia signs pact with Bernie Finklestein for his True North productions. First release, an album by Bruce Cockburn, "Words And Music" shows good gains in Ontario and Quebec. Gamma's Anthony Green and Barry Stagg have now been released world wide. Their single "To Love Means To Be Free" and album under the same title received good exposure across Canada. Compo to distribute Molten label. Donald Tarlton of Donald K. Donald Productions, one of the most successful bookers in Canada, heads up the new booking complex known as The Confederation Group, which is comprised of bookers from coast to coast. Miguel Rios' A&M lid "A Song Of Joy" breaks out in Detroit through efforts of Gerry Lacoursiere, director of Canadian operation. Tommy Hunter releases new Columbia album. Revolution Sound Studios changes name to Toronto Sound Studios. Andy Williams' summer replacement show "The Ray Stevens Show" to be taped at CFTO-TV with sound taping at Toronto Sound Studios. Ottawa's Five Man Electrical Band signs with Jim Webb's Canopy Productions. Students talk boycott of union bands for Toronto. Movement could spread across province.

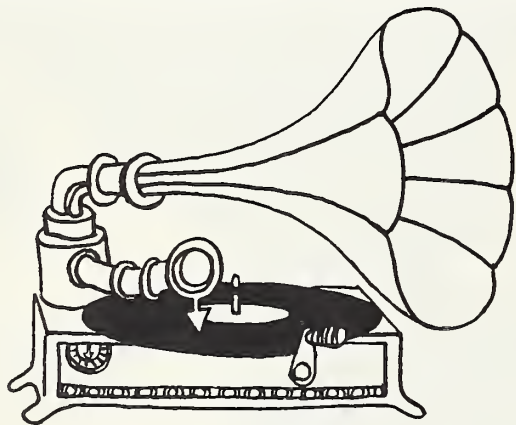

## symbol of progress

Since our company was formed in 1967 by the Philips/Polydor Organisation, our growth rate has been outstanding (to say the least!). We now represent the following labels in Australia, fostering their best interests down under!

PHILIPS • POLYDOR • MERCURY • FONTANA • MGM  
VERVE • DEUTSCHE GRAMMOPHON • ROULETTE •  
KAMA SUTRA • BUDDAH • RIVERSIDE • CAEDMON  
ZODIAC • HELIODOR

## PHONOGRAM RECORDINGS PTY. LIMITED

SYDNEY • MELBOURNE • BRISBANE • ADELAIDE • PERTH

(Con't. on Page 96)

# BELGIUM IN REVIEW

## December

A hit for "Wight is Wight" by Michel Delpech on Barclay . . . Gramophone gladly announces the acquisition of Frank Zappa's Straight label . . . It distributes Crewe Records with a first release of Oliver's "Jean" and Scepter Records with Dionne Warwick and B.J. Thomas . . . Philips released a new LP by Jimmy Frey entitled "Jimmy" . . . Colosseum performed in Antwerp . . . A new LP ("M'n beste") for Wannes Van De Velde . . . Gramophone got the permission to release the Creedence Clearwater Revival records . . . New Decca LP's for The Strangers and Willem Vermandere . . . A great come back predicted for Flemish singer John Larry . . . A big hit for J. Vincent Edwards and "Thanks."

## January

Fonior released a new single by the New Inspiration entitled "Hitchin' A Ride" . . . Arcade Records has a sensational seller with "Palma de Mallorca" by Marc Dex. Will Ferdy, one of Belgium's greatest cabaret singers, joined the Arcade label . . . Four Dutch groups in the Belgian charts: "Little Green Bag" (George Baker Selection), "Cha la la I Need You" (The Shuffles), "Mighty Joe" (Shocking Blue) and "Marian" (The Cats) . . . A new single ("Mackintosh") for The Pebbles on Barclay . . . Enrico Macias performed in the Brussels Ancienne Belgique . . . A new album for Adamo . . . The Tamla Motown records are doing very well . . . The whole Bovema team in Brussels . . . The Belgian Knokke team is formed: Mary Porcelijn, Diane, Anne Gayton, Kate and Truus.

## February

Desmond Dekker in Belgium . . . Wallace Collection in London for new re-

cordings . . . Badfinger ("Come And Get It") in Belgium . . . The carnival hit is "Pruimepap" by Johnny Jordaan . . . Tenth Barclay album in the series "Rhythm & Blues Formidable" . . . Ronnex & Teeney artists Davy Jr. and Guess Who have singles with "Mean Mister Mustard" and "Kool and the Gang" . . . Belgian viewers could enjoy RCA's Elvis Presley in one of his American TV shows . . . Polydor reports that Lola Bobesco signed a contract with the Deutsche Grammophon Gesellschaft . . . John Mayall in Theatre 140 is the pop event of the beginning of 1970 . . . Share of James Last recordings in Polydor's business figure is about 20 percent . . . Polydor gave the impulse to a daily broadcast of Beethoven's work on the Belgian National Radio . . . Daliah Lavi signed a contract with Polydor International . . . Mireille Mathieu performed in the Brussels Ancienne Belgique . . . A first single for the Antwerp pop group Paul's Collection ("Man/Music Is My Life") and the Brussels pop group Kleptomania ("Kept Woman/Out Of A Nightmare") . . . A new single for Wallace Collection: "Serenade" . . . The Scepter label started with "Rainsdrops Keep Falling On My Head" by B.J. Thomas . . . Super Atlantic show (A. Conley, Tex-Sam & Dave) in Antwerp.

## March

Philips organizes a big campaign for the Island label . . . Jean Vallee represents Belgium at the Eurovision Song Festival in Amsterdam with "Viens l'oublier" . . . Jean Kluger of Palette Records launched a Mexican campaign with the record "Balapapa" on Biram . . . Stanley Black did a concert for Radio Ghent . . . Rita Deneve has a new single: "Aan het meer van Lugano" . . . Paul van de Kerkhove is Polydor's new public relations man . . . Fantastic Polygram sales for the LP "Het Schaep met de vijf Pooten"

. . . Fleetwood Mac performed at Londerzeel . . . Polygram distributes the UNI label . . . "Joekaidi" is Marc Dex' new single . . . New Tony Joe White hit with "Roosevelt and Ira Lee" . . . Palette releases a new series of records under the label Hurrah. The first twelve LP's are by the Peter Loland Orchestra . . . Vogue distributes the Bam label in Belgium . . . Big sales for all Jose Feliciano records . . . Luc Derouwaux is Gramophone's new public relations man . . . Big activity in the classical field at Polydor Brussels . . . The RTB reported from Vienna about the first world recording of "La rappresentazione di anima e di corpo" by Emilio de Cavaliere . . . All Led Zeppelin LP's are best sellers . . . Melanie performed in Theatre 140 . . . Malcolm Roberts extremely popular.

## April

Enormous discotheque topper for "Get Ready" by Rare Earth on Rare Earth . . . Jerry Butler in Belgium . . . Georges Moustaki performed in the Brussels Ancienne Belgique . . . Gramophone's Lize Marke got the "Cerf d'Or" at the International Song Contest of Brasov in Rumania . . . Gramophone released a new series of "Country & Western" hits . . . Cliff & Henk were on TV . . . In the classical field Francois Glorieux released his first record . . . The series "Music for Pleasure" was launched . . . A new single for Ronny Temmer: "Ik ben verliefd" . . . Group Up with the People extremely popular . . . L.J. Van Rijmenant, head of Arcade Records/Eurovox Music, produced his first record for Philips since 1959 . . . Fonior signed a new Belgian group: Light Fire ("My Baby Is Sweet") . . . Simon & Garfunkel artists of the year with the LP "Bridge Over Troubled Water" and especially the single track "El Condor Pasa" . . . A new Will Tura single: "M'n airhostess."

## May

May 1st was the start of the BRT National top 30 . . . Big hit for "Tk ben Juul Kabas" by Juul Kabas . . . Roland Kluger launches his own label R.K.M. . . . The CBS hit is "El Condor Pasa" (Simon & Garfunkel) . . . Polydor's Bob Benny appointed "Ridder in de Leopold II Orde" . . . New Jimmy Frey single: "Duw een beetje" (on R.K.M.) . . . New singles for Jess & James ("The Naked") and Luigi ("Un champ d'amour") . . . New Simon & Garfunkel success with "Cecilia" . . . Creedence Clearwater Revival one of the hottest groups in Belgium . . . A big hit for Norman Greenbaum and "Spirit In The Sky" . . . A first Belgian topper for Guess Who and "American Woman" . . . Gramophone has two new series: Golden 45 records and Greatest Hits on Capitol . . . J.F. Noel is the new Fonior public relations man for the French part of Belgium . . . New singles for Louis Neefs ("Laat ons een bloem") and Marc Dex ("In je ogen").

Are you planning on a

**HIT RECORDING?**

for the right material  
(English, Italian, German)  
contact

**J. S. KORDULETSCH**

Songwriters/Publishers  
8 Munchen 5  
Ickstalt Str. 22/II

Tel: 26 41 23 Germany

IF YOU ARE LOOKING FOR OUTLET IN GERMANY — RECORDS OR PUBLISHING

go where the action is!



THE MEISEL GROUP OF COMPANIES AND HANSA SCHALLPLATTEN

Wittelsbacher Strasse 18 • 1 Berlin 31 • West Germany • New telephone number: 881 06 81

# AUSTRALIA'S MUSIC PUBLISHERS

## ACCOLADE MUSIC COMPANY PTY, LTD.

83 Miller St.  
North Sydney  
New South Wales 2060  
Phone: 920722

## J. ALBERT & SON PTY, LTD.

137-139 King St.  
Sydney  
New South Wales 2000  
Director: Mr. Edward (Ted) Albert  
Phone: 282141  
Cables: Music, Sydney

## ALLANS MUSIC (AUSTRALIA) PTY, LTD.

76 Collins Street  
Melbourne  
Victoria 3000  
Director: Mr. Rudolph Bare  
Phone: 630451  
Cables: Pianoforte, Melbourne  
Associated Companies: Acuff-Rose Publications, D. Davis & Co. Pty, Ltd.

## ANGLE MUSIC

c/ 100 Albert Road  
South Melbourne  
Victoria 3205  
Director: Mr. Roger Savage  
Phone: 692123

## APOLLO PUBLISHING CO. PTY, LTD.

1090-1140 Centre Road  
Clayton  
Victoria 3168  
Director: Mr. Neville Smith  
Phone: 5442444  
Cables: Schuh, Melbourne

## ASSOCIATED MUSIC PTY, LTD.

11 Khartoum Road  
North Ryde  
New South Wales  
Manager: Mr. Bill Donaldson  
Phone: 885444  
Cables: Radiointer, Sydney

## BOOSEY AND HAWKES (AUSTRALIA) PTY, LTD.

National Building  
250 Pitt St.  
Sydney  
New South Wales 2000  
Director: Mr. George S. Cooper  
Phone: 619046  
Cables: Sonorous, Sydney  
Associated companies:  
Jewel Music (Australia) Pty, Ltd.

## CASTLE MUSIC PTY, LTD.

381 Pitt Street,  
Sydney  
New South Wales 2000  
Manager: Mr. Phil Matthews  
Phone: 261631  
Cables: Belmusic, Sydney  
Associated companies:  
Belinda Music (Australia) Pty, Ltd  
Belcas Music Ltd, New Zealand  
Benday Music (Australia) Pty, Ltd

## CASTEL MUSIC (Con't.)

Walt Disney Publications (selling)  
T. M. Music (Australia) Pty, Ltd.  
A. Schroeder Music (Australia) Pty, Ltd.  
Rondor Music (Australia) Pty, Ltd.  
George Weiner Music (Aust) Pty, Ltd.  
Kalman Music (Australia) Pty, Ltd.  
Johnny Devlin Music Pty, Ltd.  
Lonnie Lee Music Pty, Ltd.  
Williams-Conde Music Pty, Ltd.  
Progressive Music (Aust) Pty, Ltd.  
Palace Music Pty, Ltd.  
Ivan Mogull Music (Aust) Pty, Ltd.

## CHAPPELL & CO. LTD.

68-70 Clarence Street,  
Sydney  
New South Wales 2000  
Manager: Mr. Basil Ahrens  
Phone: 294681  
Cables: Symphony, Sydney  
Associated companies:  
Edwin Morris & Co. Ltd.  
Sterling Music Publishing Company  
Aberbach (Australian) Pty, Ltd.  
Comet Music (Australia) Pty, Ltd.  
Five Continents Chappell Pty, Ltd.  
Robert Mellin Pty, Ltd.  
Wallaby Music Pty, Ltd.

## JULY MUSIC

8 Francis Street,  
Heathmont  
Victoria 3135  
Phone: 8705677  
Cables: Rondor, Melbourne

## WALT DISNEY MUSIC PTY, LTD.

149 Castlereagh Street,  
Sydney  
New South Wales 2000  
Director: Mr. Walter Granger,  
Phone: 618942  
Cables: Mickmouse, Sydney  
Selling agents: Castle Music Pty, Ltd.

## ESSEX MUSIC OF AUSTRALIA PTY, LTD.

32-34 York Street  
Sydney  
New South Wales 2000  
Manager: Mr. Barry Kimberley  
Phone: 298595  
Cables: Semus, Sydney  
Associated companies:  
Cromwell Music of Australia Pty, Ltd.  
Sydney Tree Pty, Ltd.  
Arwin Music of Australia Pty, Ltd.  
Barton Music (Australia) Pty, Ltd.  
Apple Music Pty, Ltd.

## LEEDS MUSIC PTY, LTD.

Pelican Street  
Darlinghurst  
New South Wales 2000  
General Manager: Mr. Jack Argent  
Phone: 616088  
Cables: Leeds music, Sydney  
Associated companies:

## LEEDS MUSIC (Con't.)

Tu-Con Music Pty, Ltd.  
Tangerine Music Pty, Ltd.  
Spoone Music Pty, Ltd.  
Pincus Gil Pty, Ltd.  
Cricknet Music Pty, Ltd.  
Victoria Music Company  
Northern Songs Pty, Ltd.  
Dick James Music Pty, Ltd.  
Jaep Music Pty, Ltd.  
Pacer Music Pty, Ltd.  
Screen-Gems Columbia Music Pty, Ltd.  
Crown Music Pty, Ltd.

## W. H. PALING & CO. PTY, LTD.

338 George Street,  
Sydney  
New South Wales 2000  
Associated companies:  
Nicholson's Pty, Ltd.  
Also representing M.C.P.S. of England

## SOUTHERN MUSIC PUBLISHING CO. (AUSTRALASIA) PTY, LTD.

38-40 York Street  
Sydney  
New South Wales 2000  
Managing Director: Mr. Chris Vaughn-Smith  
Phone: 292547  
Cables: Southmusic, Sydney  
Associated companies:  
Peer International Pty, Ltd.  
Music Publishing Co. (Aust) Pty, Ltd.  
Sam Fox Publishing Co. (Aust) Pty, Ltd.  
World Music Publishing Co. Pty, Ltd.

## NORMAN WHITELEY HOLDINGS PTY, LTD.

100 Clarence Street  
Sydney  
New South Wales 2000  
Managing Director: Mr. Norman Whiteley  
Phone: 291050  
Cables: Abisong, Sydney  
Associated companies:  
Abigail Music (Australia) Pty, Ltd.  
Penjane Music (Australia) Pty, Ltd.  
Dratleaf Music (Australia) Pty, Ltd.  
Pamper Music of Australia Pty, Ltd.  
Planetary-Nom (Australia) Pty, Ltd.  
Paul Wayne Music Pty, Ltd.

## WOOMERA MUSIC PTY, LTD.

185-187 A'Beckett St.  
Melbourne  
Victoria 3000  
Managing Director: Mr. Ron Gillespie  
Phone: 3297255  
Cables: Dualscale, Melbourne  
Associated company: Spanka Music Pty, Ltd.

## WORLD ARTISTS INCORPORATED PTY, LTD.

200 Goulburn Street  
Sydney  
New South Wales 2000  
Phone: 211577  
Cables: Phonorec, Sydney  
Selling agents for this company are Chappell & Co. Ltd.

## Australia The Past 12 Months

(Con't. from Page 94)

play an imported record until a period of seven weeks has elapsed since the disc was first issued in its country of origin.

As reported some weeks back, this regulation has never really been enforced, but it now seems likely that the major disc concerns will use it to the full in an effort to block the broadcasters. The regulation originally came into being because stations were, and still are to this time, receiving imports so quickly and getting them to air far in advance of record companies receiving their copies.

The imports often receive heavy radio saturation, whereupon a large slice of actual disc sales is lost by the time the record company gets the disc to the local market.

Locally-produced cover versions do not come under this restriction and can be broadcast within the seven week embargo period. So it can be seen that "cover" versions of overseas originals have every chance possible of gaining acceptance with radio station programmers and the buying public many weeks before an imported hit has the chance of being heard. The major companies have still bigger problems on their hands. With no end to the dispute in sight, some influential factions are going ahead with plans to move into the record producing business themselves. One such company will bring together the Herald and Weekly Times Ltd; the Macquarie Broadcasting Network, and a Sydney-based television station ATN Channel Seven. Several other key broadcasting concerns also have plans well in advance in this regard. These new companies will operate to the

obvious detriment of established record companies. But it must also be understood that if it were not for the established companies insistence in enforcing the new Copyright regulation in the first place; there would be no need for rival companies to come into being at all.

Competition is of course a good thing, but many people involved in the industry find it regrettable that new, relatively inexperienced factions should have been allowed to spring up out of the present dispute.

These new interests while concerning themselves initially with local production on the home-front, will no doubt have plans to enter into franchise arrangements with overseas outlets for the manufacture and marketing of overseas records through Australia. This latter point is naturally of increasing concern to the established record companies.

We made mention earlier of the fact that television stations are not affected by the dispute. Many record executives feel that in the light of the present radio shut-down on their local and English material, television could be an important outlet for exposure of product. Several reports claim disc programmes are in the wind, and this form of exposure could well result in the discovery of a completely new disc promotion medium.

What with our population growing so rapidly and the ever-increasing demands of a keen record-buying public, it may not be such a dark cloud hanging over the Australian scene as was first thought. No matter what the eventual outcome of this business, the winds of change are definitely beginning to blow, and one can perhaps forecast a bigger and brighter future stemming out of what is undoubtedly a tragic and to many, unnecessary dispute.



## GAMMA, S.A.

specializes in promotion  
and distribution of  
international catalogs  
in Mexico.

Ejército Nacional 167. P.O. Box 7762  
México I. D. F. MEXICO (Phone: 545-73-60)

## Internationally

## It's What's

## in

## CASH BOX

## That Counts